

## Double Layer Capacitors

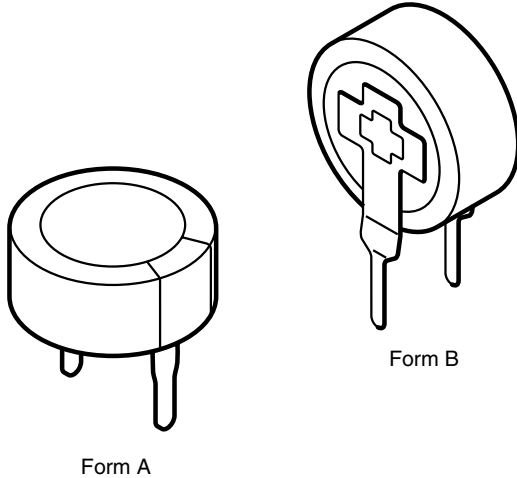

Fig.1 Component outline

### FEATURES

- Polarized capacitor with high charge density, alternative product to rechargeable backup batteries
- Dielectric: electric double layer
- Radial leads, cylindrical case, insulated with a blue vinyl sleeve
- Available in both vertical and low-profile versions
- Unlimited charge and discharge cycle numbers
- No charge-discharge control circuitry and no series resistor necessary
- Maintenance-free, no periodic replacement or service necessary
- Ecologically beneficial (no Cd, no Li)
- Lead (Pb)-free versions are RoHS compliant



**RoHS**  
COMPLIANT

### APPLICATIONS

- Energy storage, for backup of semiconductor memories (CMOS) in all fields of electronics
- Telecommunication, audio-video, EDP
- General industrial, clock and timer systems

### MARKING

The capacitors are marked with the following information:

- Rated capacitance (in F)
- Rated voltage (in V)
- Date code, in accordance with IEC 60062
- Name of manufacturer
- Negative terminal identification
- Upper category temperature (at 85 °C types only)

QUICK REFERENCE DATA				
DESCRIPTION	VALUE			
	STANDARD FORM A	HIGH VOLTAGE FORM A	HIGH TEMPERATURE FORM A	VERTICAL, MINIATURIZED FORM B
Nominal case sizes (Ø D x L in mm)	13 x 7 and 21 x 7.5	13 x 9 and 21 x 9	13 x 9 and 21 x 9	11.5 x 13 (vertical)
Rated capacitance range, C <sub>R</sub>	0.047 to 1.0 F	0.047 to 0.68 F	0.047 to 0.68 F	0.047 to 0.33 F
Tolerance on C <sub>R</sub> at 20 °C	- 20 to + 80 %			
Rated voltage, U <sub>R</sub>	5.5 V	6.3 V	5.5 V	5.5 V
Maximum surge voltage, U <sub>S</sub>	6.3 V	7.0 V	6.3 V	6.3 V
Category temperature range	- 25 to + 70 °C	- 25 to + 70 °C	- 25 to + 85 °C	- 25 to + 70 °C
Useful life at U <sub>R</sub> :				
at 85 °C	-	-	1000 hours	-
at 70 °C	1000 hours	1000 hours	2800 hours	1000 hours
at 40 °C	8000 hours	8000 hours	23 000 hours	8000 hours
at 25 °C	23 000 hours	23 000 hours	64 000 hours	23 000 hours
Shelf life at 0 V	1000 hours at upper category temperature			
Climatic category IEC 60068	25/070/21	25/070/21	25/085/21	25/070/21

<b>SELECTION CHART FOR <math>C_R</math>, <math>U_R</math> AND FORM AT UPPER CATEGORY TEMPERATURE (UCT)</b>				
$C_R$ (F)	FORM	$U_R = 5.5 V$		$U_R = 6.3 V$
		UCT = 85 °C	UCT = 70 °C	UCT = 70 °C
0.047	A	13 x 9	13 x 7	13 x 9
	B	-	11.5 x 13	-
0.1	A	13 x 9	13 x 7	13 x 9
	B	-	11.5 x 13	-
0.22	A	-	13 x 7	-
	B	-	11.5 x 13	-
0.33	A	-	13 x 7	-
	B	-	11.5 x 13	-
0.47	A	21 x 9	21 x 7.5	21 x 9
	B	-	-	-
0.68	A	21 x 9	-	21 x 9
	B	-	-	-
1.0	A	-	21 x 7.5	-

**DIMENSIONS** in millimeters **AND AVAILABLE FORMS**

Fig.2 Form A: Low profile

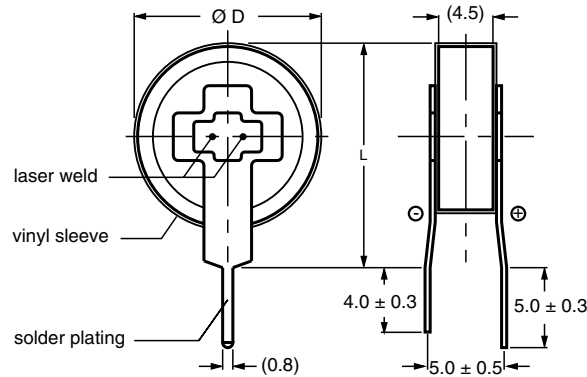

Fig.3 Form B: Vertical

<b>DIMENSIONS</b> in millimeters, <b>MASS AND PACKAGING QUANTITIES</b>						
NOMINAL CASE SIZE $\varnothing D \times L$ (mm)	CASE CODE	FORM	$\varnothing D_{max.}$	$L_{max.}$	MASS (g)	PACKAGING QUANTITIES
11.5 x 13	1	B	11.8	13.5	≈ 1.5	2000
13 x 7	2	A	13.5	7.5	≈ 2.8	1000
13 x 9	3	A	13.5	9.5	≈ 3.4	1000
21 x 7.5	4	A	21.5	8.0	≈ 7.1	500
21 x 9	5	A	21.5	9.5	≈ 8.8	500

**Note**

Detailed tape dimensions see section 'PACKAGING'

ELECTRICAL DATA	
SYMBOL	DESCRIPTION
$C_R$	rated capacitance, tolerance - 20/+ 80 %, measured by constant current discharge method
UCT	upper category temperature
$I_L$	max. leakage current after 30 minutes at $U_R$
$R_I$	max. internal resistance at 1 kHz

**ORDERING EXAMPLE**

Double layer capacitor 196 series

1.0 F/5.5 V

Nominal case size:  $\varnothing$  21 x 7.5 mm; Form A

Ordering code: MAL219612105E3

Former 12 NC: 2222 196 12105

**Note**

Unless otherwise specified, all electrical values in Table 1 apply at  $T_{amb} = 20\text{ }^\circ\text{C}$ ,  $P = 86$  to  $106\text{ kPa}$  and  $RH = 45$  to  $75\%$ .

Table 1

ELECTRICAL DATA AND ORDERING INFORMATION								
$U_R$ (V)	$C_R$ (F)	NOMINAL CASE SIZE $\varnothing$ D x L (mm)	CASE CODE	FORM	UCT ( $^\circ\text{C}$ )	$I_L$ 30 min. ( $\mu\text{A}$ )	$R_I$ 1 kHz ( $\Omega$ )	ORDERING CODE
<b>Standard series</b>								
5.5	0.047	13 x 7	2	A	70	69	120	MAL219612473E3
	0.1	13 x 7	2	A	70	100	75	MAL219612104E3
	0.22	13 x 7	2	A	70	135	75	MAL219612224E3
	0.33	13 x 7	2	A	70	182	75	MAL219612334E3
	0.47	21 x 7.5	4	A	70	216	30	MAL219612474E3
	1.0	21 x 7.5	4	A	70	315	30	MAL219612105E3
<b>High temperature series</b>								
5.5	0.047	13 x 9	3	A	85	69	300	MAL219622473E3
	0.1	13 x 9	3	A	85	100	200	MAL219622104E3
	0.47	21 x 9	5	A	85	216	50	MAL219622474E3
	0.68	21 x 9	5	A	85	260	50	MAL219622684E3
<b>Vertical, miniaturized series</b>								
5.5	0.047	11.5 x 13	1	B	70	69	120	MAL219632473E3
	0.1	11.5 x 13	1	B	70	100	75	MAL219632104E3
	0.22	11.5 x 13	1	B	70	135	75	MAL219632224E3
	0.33	11.5 x 13	1	B	70	182	75	MAL219632334E3
<b>High voltage series</b>								
6.3	0.047	13 x 9	3	A	70	69	300	MAL219613473E3
	0.1	13 x 9	3	A	70	100	200	MAL219613104E3
	0.47	21 x 9	5	A	70	216	50	MAL219613474E3
	0.68	21 x 9	5	A	70	260	50	MAL219613684E3

**MEASURING OF CHARACTERISTICS**

**CAPACITANCE (C)**

Capacitance shall be measured by constant current discharge method.

DISCHARGE CURRENT AS A FUNCTION OF RATED CAPACITANCE								
PARAMETER	VALUE							UNIT
Rated capacitance, C <sub>R</sub>	0.047	0.1	0.22	0.33	0.47	0.68	1.0	F
Discharge current, I <sub>D</sub>	0.1			1.0				mA



Fig.4 Voltage diagram for capacitance measurement

Capacitance value C<sub>R</sub> is given by discharge current I<sub>D</sub>, time T and rated voltage U<sub>R</sub>, according to the following equation:

$$C(F) = \frac{I_D(mA) \times 10^{-3} \times T(s)}{U_R(V) - 2}$$



Fig.5 Test circuit for capacitance measurement

**INTERNAL RESISTANCE (R<sub>I</sub>) AT 1 kHz**

$$R_I(\Omega) = \frac{V_C(V)}{10^{-3}}$$



Fig.6 Test circuit for R<sub>I</sub> measurement

**LEAKAGE CURRENT (I<sub>L</sub>)**

Leakage current shall be measured after 30 minutes application of rated voltage U<sub>R</sub>:

$$I_L(\mu A) = \frac{V(V)}{10^{-4}}$$



Fig.7 Test circuit for leakage current



Fig.8 Typical leakage current as a function of time



**DISCHARGE CHARACTERISTICS**

Backup time of 196 DLC series capacitors depends on minimum memory holding voltage and discharge current (corresponding with the current consumption of the load). For minimum backup times of standard and vertical miniaturized series see Figs 9 and 10 (charging time  $\geq 24$  hours).

Figure 11 shows the backup time when a 196 DLC capacitor is discharged by a constant resistance (charging time  $\geq 24$  hours).

The horizontal axis shows the initial value of discharge current if 5 V is connected to the capacitor via a fixed series resistor.

**EXAMPLE: 1  $\mu$ A CORRESPONDS TO 5 M $\Omega$  AND 0.1  $\mu$ A CORRESPONDS TO 50 M $\Omega$**

The vertical axis shows that period of time during which the voltage drops from 5 to 2 V.

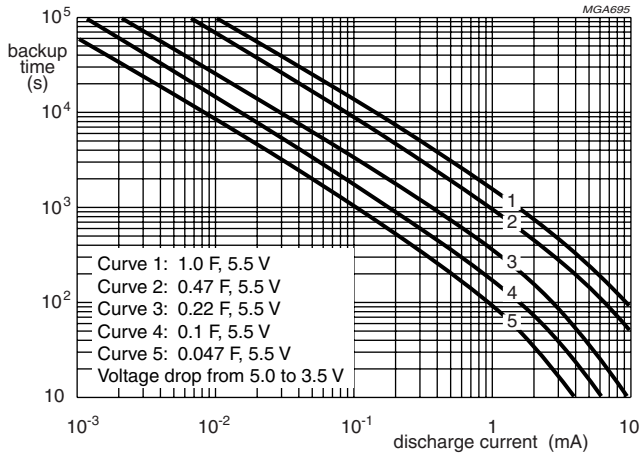

Fig.9 Typical backup time as a function of discharge current



Fig.11 Typical backup time as a function of initial discharge current



Fig.10 Typical backup time as a function of discharge current

Table 2

<b>TEST PROCEDURES AND REQUIREMENTS</b> for standard and vertical miniaturized series (5.5 V; 70 °C)			
<b>NAME OF TEST</b>	<b>IEC 60384-4/ EN130300 subclause</b>	<b>PROCEDURE (quick reference)</b>	<b>REQUIREMENTS</b>
Robustness of terminations	4.4	tensile strength; application of loading force for 10 seconds: 20 N (standard series) 5 N (vertical miniaturized series)	no breaks
Resistance to soldering heat	4.5	solder bath; 260 °C; 5 seconds	$\Delta C/C: \pm 10 \%$ $R_1$ and $I_L \leq$ spec. limit
Solderability	4.6	solder bath; 235 °C; 2 seconds	$\geq 75 \%$ tinning
Vibration	4.8	10 to 55 Hz; 1.5 mm; 3 directions; 2 hours per direction	$\Delta C/C: \pm 10 \%$ $R_1$ and $I_L \leq$ spec. limit
Damp heat, steady state	4.12	500 hours at 55 °C; RH 90 to 95 %; no voltage applied	$\Delta C/C: \pm 30 \%$ $R_1 \leq 4 \times$ spec. limit $I_L \leq 2 \times$ spec. limit
Endurance	4.13	$T_{amb} = 70 \text{ °C}$ ; 5.5 V applied; 1000 hours	$\Delta C/C: \pm 30 \%$ $R_1 \leq 4 \times$ spec. limit $I_L \leq 2 \times$ spec. limit
Storage at upper category temperature	4.17	$T_{amb} = 70 \text{ °C}$ ; no voltage applied; 1000 hours	$\Delta C/C: \pm 30 \%$ $R_1 \leq 4 \times$ spec. limit $I_L \leq 2 \times$ spec. limit
Self discharge	-	24 hours storage at room temperature after application of 5 V for 1 hour	remaining voltage: $\geq 4 \text{ V}$
Characteristics at high and low temperature	4.19	step 1: reference measurement at + 20 °C of C, $R_1$ and $I_L$ step 2: measurement at - 25 °C step 3: measurement at + 20 °C step 4: measurement at + 70 °C step 5: measurement at + 20 °C	$\Delta C/C: \pm 30 \%$ of + 20 °C value $R_1 \leq 5 \times$ the + 20 °C value $I_L \leq 4 \times$ the + 20 °C value



## Disclaimer

All product specifications and data are subject to change without notice.

Vishay Intertechnology, Inc., its affiliates, agents, and employees, and all persons acting on its or their behalf (collectively, "Vishay"), disclaim any and all liability for any errors, inaccuracies or incompleteness contained herein or in any other disclosure relating to any product.

Vishay disclaims any and all liability arising out of the use or application of any product described herein or of any information provided herein to the maximum extent permitted by law. The product specifications do not expand or otherwise modify Vishay's terms and conditions of purchase, including but not limited to the warranty expressed therein, which apply to these products.

No license, express or implied, by estoppel or otherwise, to any intellectual property rights is granted by this document or by any conduct of Vishay.

The products shown herein are not designed for use in medical, life-saving, or life-sustaining applications unless otherwise expressly indicated. Customers using or selling Vishay products not expressly indicated for use in such applications do so entirely at their own risk and agree to fully indemnify Vishay for any damages arising or resulting from such use or sale. Please contact authorized Vishay personnel to obtain written terms and conditions regarding products designed for such applications.

Product names and markings noted herein may be trademarks of their respective owners.

## Данный компонент на территории Российской Федерации

### Вы можете приобрести в компании MosChip.

Для оперативного оформления запроса Вам необходимо перейти по данной ссылке:

<http://moschip.ru/get-element>

Вы можете разместить у нас заказ для любого Вашего проекта, будь то серийное производство или разработка единичного прибора.

В нашем ассортименте представлены ведущие мировые производители активных и пассивных электронных компонентов.

Нашей специализацией является поставка электронной компонентной базы двойного назначения, продукции таких производителей как XILINX, Intel (ex.ALTERA), Vicor, Microchip, Texas Instruments, Analog Devices, Mini-Circuits, Amphenol, Glenair.

Сотрудничество с глобальными дистрибьюторами электронных компонентов, предоставляет возможность заказывать и получать с международных складов практически любой перечень компонентов в оптимальные для Вас сроки.

На всех этапах разработки и производства наши партнеры могут получить квалифицированную поддержку опытных инженеров.

Система менеджмента качества компании отвечает требованиям в соответствии с ГОСТ Р ИСО 9001, ГОСТ РВ 0015-002 и ЭС РД 009

### Офис по работе с юридическими лицами:

105318, г.Москва, ул.Щербаковская д.3, офис 1107, 1118, ДЦ «Щербаковский»

Телефон: +7 495 668-12-70 (многоканальный)

Факс: +7 495 668-12-70 (доб.304)

E-mail: [info@moschip.ru](mailto:info@moschip.ru)

Skype отдела продаж:

moschip.ru

moschip.ru\_4

moschip.ru\_6

moschip.ru\_9