

# S86R/S87R series

## Low Cost 20 Amp Industrial Relays

UL File E22575

CS File LR15734



**S86R  
Mounting  
Style 1**

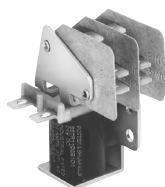

**S87R  
Mounting  
Style 2**

Users should thoroughly review the technical data before selecting a product part number. It is recommended that users also seek out the pertinent approvals files of the agencies/laboratories and review them to ensure the product meets the requirements for a given application.

### Features

- Low cost.
- Contact forms to 2 Form C.
- Applications include spa controls, vending machines, HVAC, and machine tool controls.
- Variety of mounting styles.

### Contact Data @ 25°C

**S86R and S87R:** 20 amps @ 277VAC; 60 LRA, 12 FLA, 1 HP @ 125VAC;  
48 LRA, 8 FLA @ 240VAC; 2 HP @ 250VAC; Pilot  
Duty, 360VA @ 125/250VAC.

**Materials:** Silver and silver-cadmium oxide.

**Expected Life:** 1 million operations, mechanical; 50,000 operations at rated loads.

### Initial Dielectric Strength

**Initial Breakdown Voltage:** 1,560V rms, 60 Hz.

### Coil Data @ 25°C

#### Nominal Power:

**S86R:** 4.0VA for AC models.

**S87R:** 2.9 Watts for single pole DC models.  
4.5 Watts for double pole DC models.  
4.0VA for AC models.

**Insulation:** Class B (130°C).

### Coil Data

Nominal Coil Voltage	Coil Resistance (Ohms)		Nominal Coil Current (mA) @ 25°C*	
	AC, ± 15% DC, ± 10%			
<b>S86R &amp; S87R (AC)</b>	All Models		All Models	
12VAC	8.0		330	
24VAC	32		165	
120VAC	800		33.0	
240VAC	3,200		16.5	
<b>S87R (DC)</b>	Single Pole Models	Double Pole Models	Single Pole Models	Double Pole Models
6VDC	12.5	8	480	750
12VDC	50	32	240	375
24VDC	200	128	120	188
36VDC	450	288	80	125
48VDC	800	512	60	94
72VDC	1,800	1,150	40	63
125VDC	5,425	3,470	23	36

\*Increase AC current values by 25% for mounting style 2 with single switch.

### Operate Data

#### Must Operate Voltage:

**DC Coils:** 75% of nominal voltage @ +25°C.

**AC Coils:** 85% of nominal voltage @ +25°C.

**Operating Position:** Relay is designed for operation with plunger either vertical or horizontal; however, the relay is not designed for operation in an upside-down position.

### Environmental Data

**Temperature Range:** -10°C to +65°C.

Ordering Information

Typical Part No. ▶ **S86R 5 A 1 B 1 D 1 -120**

1. Basic Series:

S86R = Standard relay with AC coil, 20 Amp contacts.  
S87R = Standard relay with AC or DC coil, 20 Amp contacts.

2. Contact Arrangement:

5 = SPDT 7 = DPST-NO 11 = DPDT

3. Coil Input:

A = AC (available on S86R and S87R)  
D = DC (available on S87R only)

4. Mounting Style:

S86: S87: (See outline dimensions)  
1 = Style 1 2 = Style 2

5. Coil Terminal Style:

B = .250" (6.35mm) Quick-connect/solder.

6. Coil Terminal Location (S86):

1 = Same side as switch terminals.

Coil Terminal Location (S87):

1 = Located perpendicular to switch terminals.

7. Switch Terminal Style:

D = .250" (6.35mm) Quick-connect/solder.

8. Switch Terminal Configuration:

1 = Style 1

9. Coil Voltage:

AC coils to 240VAC, 50/60 Hz.  
DC coils to 125VDC.

Our authorized distributors are more likely to maintain the following items in stock for immediate delivery.

S86R5A1B1D1-120  
S86R11A1B1D1120

S86R11D1B1D1-12  
S87R5A2B1D1-120

S87R5A2B1D1-240  
S87R5D2B1D1-24

S87R11A2B1D1-24  
S87R11A2B1D1120

S87R11A2B1D1240  
S87R11D2B1D1-110

Outline Dimensions

S86R (2 pole shown) Style 1

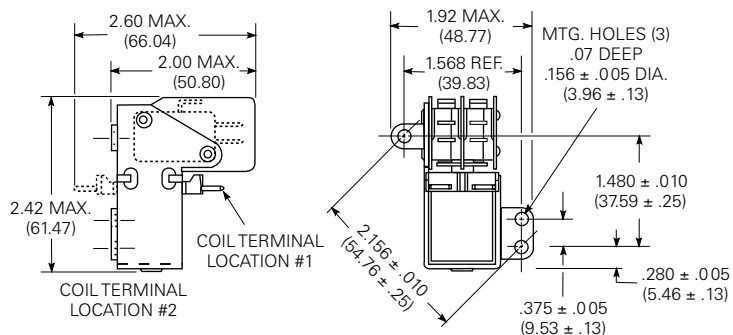

S87R (2 pole shown) Style 2

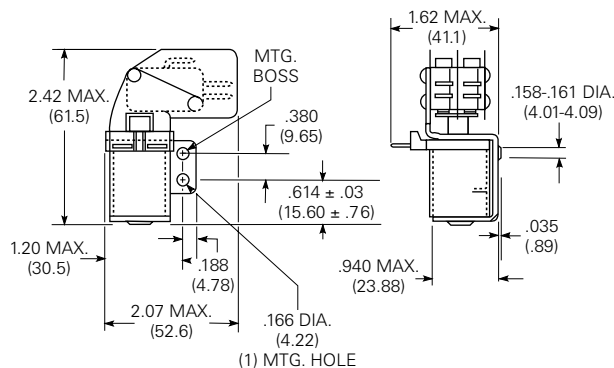

Switch Terminal Style

.250" (6.35mm) Quick Connect

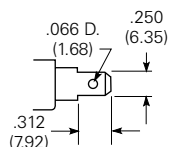

Switch Terminal Configuration

Style 1

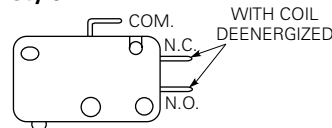

## Данный компонент на территории Российской Федерации

### Вы можете приобрести в компании MosChip.

Для оперативного оформления запроса Вам необходимо перейти по данной ссылке:

<http://moschip.ru/get-element>

Вы можете разместить у нас заказ для любого Вашего проекта, будь то серийное производство или разработка единичного прибора.

В нашем ассортименте представлены ведущие мировые производители активных и пассивных электронных компонентов.

Нашей специализацией является поставка электронной компонентной базы двойного назначения, продукции таких производителей как XILINX, Intel (ex.ALTERA), Vicor, Microchip, Texas Instruments, Analog Devices, Mini-Circuits, Amphenol, Glenair.

Сотрудничество с глобальными дистрибьюторами электронных компонентов, предоставляет возможность заказывать и получать с международных складов практически любой перечень компонентов в оптимальные для Вас сроки.

На всех этапах разработки и производства наши партнеры могут получить квалифицированную поддержку опытных инженеров.

Система менеджмента качества компании отвечает требованиям в соответствии с ГОСТ Р ИСО 9001, ГОСТ РВ 0015-002 и ЭС РД 009

### Офис по работе с юридическими лицами:

105318, г.Москва, ул.Щербаковская д.3, офис 1107, 1118, ДЦ «Щербаковский»

Телефон: +7 495 668-12-70 (многоканальный)

Факс: +7 495 668-12-70 (доб.304)

E-mail: [info@moschip.ru](mailto:info@moschip.ru)

Skype отдела продаж:

moschip.ru

moschip.ru\_4

moschip.ru\_6

moschip.ru\_9