

## Specification

### Small Form Factor Pluggable

Simplex LC Receptacle – SFP BIDI

### OLT - Bidirectional Optical Transceivers

STM-1 / OC-3 / 100BASE-BX10-D  
 155.52Mbit/s



## Ordering Information

**T B D - S x A C 1 - G 1 1**



**Category**  
 BD : DDMI Product



**Voltage / Temperature**  
 1 : 3.3V / +0°C ~ +70°C  
 2 : 3.3V / -40°C ~ +85°C

Model Name	Voltage	Category	Device type	Interface	SD/LOS	Temperature	Distance	Latch Color
TBD-S1AC1-G11	3.3V	With DDMI	FP / PIN	AC / AC Coupling	LVTTTL	+0°C~+70°C	20km	Blue
TBD-S2AC1-G11						-40°C~+85°C		

## Features

- ROHS Compliant
- Standard Small Form Factor Pluggable Package – SFP MSA Compliant
- Digital Diagnostic SFF-8472 Rev.10.2 Compliant
- SONET/SDH Standard Compliant
- IEEE802.3AH 100BASE-BX10-D Compliant
- Laser Class 1 Product – IEC60825-1 Compliant
- Standard Simplex LC Receptacle Optical Interface
- Single Fiber and Full Duplex Solution – Integrated WDM Filter
- Single + 3.3 V Power Supply
- Differential LVPECL Data Input and Output
- LVTTTL Loss of Signal
- Serial ID through I<sup>2</sup>C Interface
- Low Power Consumption

## Absolute Maximum Ratings

Parameter	Symbol	Min	Typ	Max	Unit
Storage temperature	T <sub>s</sub>	-40	--	85	°C
Supply voltage	V <sub>CC</sub>	0	--	4	V
Operating Relative Humidity	--	5	--	95	%
Input voltage	V <sub>IN</sub>	0	--	V <sub>CC</sub>	V

## Operating Conditions

Parameter	Symbol	Min	Typ	Max	Unit
Supply Voltage	V <sub>CC</sub>	3.1	3.3	3.5	V
Operating Case temperature ( TBD-S1AC1-G11 )	T <sub>c</sub>	0	--	70	°C
Operating Case temperature ( TBD-S2AC1-G11 )		-40	--	85	
Total Current ( Transmitter + Receiver )	I <sub>CC</sub>	--	--	250	mA

**Transmitter Specifications** (  $V_{CC}=3.1V\sim 3.5V$  ;  $T_C= 0^{\circ}C\sim 70^{\circ}C$  /  $T_C= -40^{\circ}C\sim 85^{\circ}C$  )

Parameter	Symbol	Min	Typ	Max	Unit
<b>Optical Characteristics</b>					
Output Optical Power	$P_{out}$	-14	--	-8	dBm
Extinction Ratio	ER	9	--	--	dB
Center Wavelength	$\lambda_C$	1480	--	1580	nm
Spectral Width (RMS)	$\sigma$	--	--	4.6	nm
Rise/Fall time (10-90%)	$T_{r,f}$	--	--	2	ns
Output Eye	Compliant with ITU-T G.957				
Max. $P_{out}$ TX-DISABLE Asserted	$P_{OFF}$	--	--	-45	dBm
<b>Electrical Characteristics</b>					
Differential Input Voltage	$V_{DIFF}$	0.4	--	2.0	V
Tx_Disable_Input_High	$V_{DISH}$	2.0	--	$V_{CC}+0.3$	V
Tx_Disable_Input_Low	$V_{DISL}$	0	--	0.8	V
Tx_Fault_Output_High	$V_{FH}$	2.0	--	$V_{CC}+0.3$	V
Tx_Fault_Output_Low	$V_{FL}$	0	--	0.8	V

**Receiver Specifications** (  $V_{CC}=3.1V\sim 3.5V$  ;  $T_C= 0^{\circ}C\sim 70^{\circ}C$  /  $T_C= -40^{\circ}C\sim 85^{\circ}C$  )

Parameter	Symbol	Min	Typ	Max	Unit
<b>Optical Characteristics</b>					
Optical Input Power-maximum	$P_{SATIN}$	-3	--	--	dBm
Receiver Sensitivity ( PRBS= $2^{23}-1$ ; BER $\leq 10^{-10}$ )	$P_{SAN}$	--	--	-32	dBm
Operating Center Wavelength	$\lambda_c$	1260	--	1360	nm
Optical Return Loss	ORL	14	--	--	dB
Loss of Signal – De-asserted	$P_{LD}$	--	--	-32	dBm
Loss of Signal - Asserted	$P_{LA}$	-45	--	--	dBm
Loss of Signal - Hysteresis	$P_{LH}$	0.5	--	6	dB
<b>Electrical Characteristics</b>					
Differential Output Voltage	$V_{DIFF}$	0.4	--	2.0	V
Receiver Loss of Signal Output Voltage -Low	$V_{LOSL}$	0	--	0.8	V
Receiver Loss of Signal Output Voltage -High	$V_{LOSH}$	2	--	$V_{CC}+0.3$	V

## Pin Definition and Descriptions

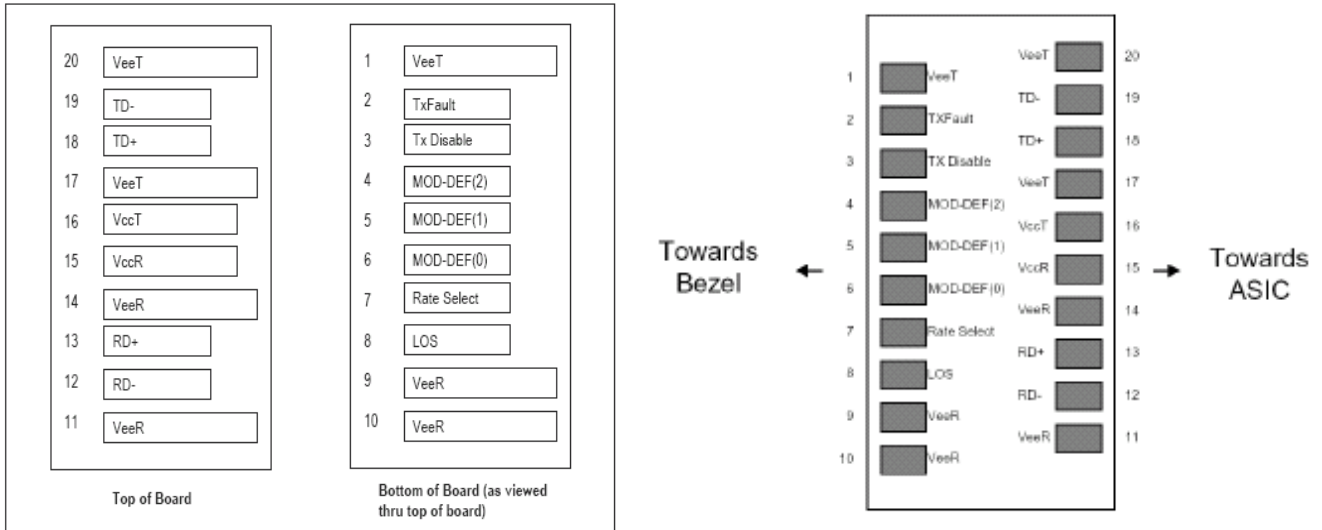

Pin	Name	Input/Output Level	Description
1	VeeT	Input	Transmitter ground
2	TXFault	Output/LVTTL	Laser failure indication. High level indicates "laser failure". Externally pulled up
3	TXDisable	Input/LVTTL	Transmitter disable, High signal/open disables TX laser output. Low level enables TX output, internally pulled up.
4	MOD-DEF(2)	Input/output	Module definition 2, SDA, Data line for I2C bus. Externally pulled up
5	MOD-DEF(1)	Input	Module definition 1, SCL, Clock for I2C bus. Externally pulled up
6	MOD-DEF(0)	Output	Module definition 0, Module present. Ground inside module.
7	Rate Select	-	No connection.
8	LOS	Output/LVTTL	Receiver loss of signal indication. Low signal indicates optical signal is present at RX input. Should be Externally pulled up.
9	VeeR	Input	Receiver ground
10	VeeR	Input	Receiver ground
11	VeeR	Input	Receiver ground
12	RD -	Output/CML	Inverted receiver data output (AC coupled)
13	RD +	Output/CML	Non-inverted receiver data output (AC coupled)
14	VeeR	Input	Receiver ground
15	VccR	Input	Receiver power supply
16	VccT	Input	Transmitter power supply
17	VeeT	Input	Transmitter ground
18	TD +	Input/LVPECL	non-inverted transmitter data input (AC coupled)
19	TD -	Input/LVPECL	Inverted transmitter data input (AC coupled)
20	VeeT	Input	Transmitter ground

Recommended Circuit Diagram

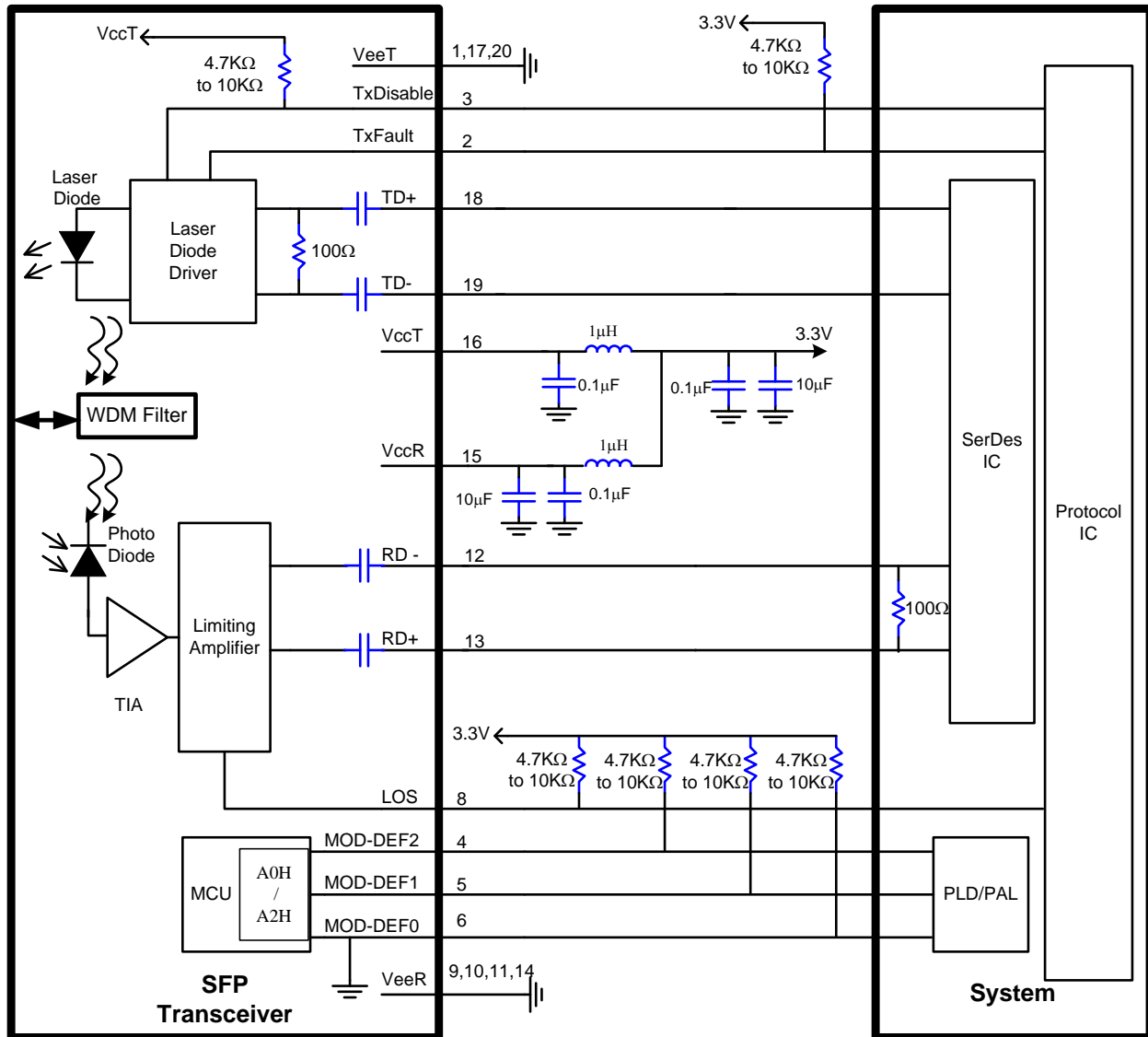

**Content in 2-Wire Address A0H**

Address	HEX	Name of Field	Description
00	03	Identifier	SFP
01	04	Extended Identifier	SFP
02	07	Connector type	LC
03	00	Infiniband Compliance Codes	Not compliant
04	08	SONET Compliance Codes	SONET IR-2 compliant
05	02	SONET Compliance Codes	OC-3, single mode, inter. reach
06	00	Ethernet Compliance Codes	Not compliant
07	00	Fiber Channel link length	Not compliant
08	00	Fiber Channel transmitter technology	Not compliant
09	00	Fiber Channel transmission media	Not compliant
10	00	Fiber Channel speed	Not compliant
11	03	Encoding codes:	NRZ
12	02	Nominal Bit Rate (units of 100Mbps)	200Mbps
13	00	Rate identifier	Unspecified
14	14	Link length supported for 9um fiber	20 (units of km)
15	C8	Link length supported for 9um fiber	200 (units of 100m)
16	00	Link length supported for 50um,OM2	N/A (units of 10m)
17	00	Link length supported for 62.5um,OM1	N/A(units of 10m)
18	00	Link length supported for copper	N/A (units of 1m)
19	00	Link length supported for 50um,OM3	N/A (units of 10m)
20 ~ 35	46,4F,52,4D,45,52,49,43,41,4F,45,20,20,20,20,20	Vendor Name	FORMERICA OE
36	00	Unallocated	
37 ~ 39	00,00,00	Vendor OUI	Unspecified
40 ~ 55	54,42,44,2D,53,31(32),41,43,31,2D,47,31,31,20,20,20	Part Number	TBD-S1(2)AC1-G11
56 ~ 59	00,00,00,00	Vendor Revision number	Unspecified
60 ~ 61	06,0E	Laser Wavelength	1550nm
62	00	Unallocated	
63		CC_BASE:	Check sum of byte 0 ~ 62
64	00	Options	
65	1A	Options	TX-DIS, TX_FAULT, RX-LOS
66	00	Bit Rate, max.	Unspecified
67	00	Bit Rate, min.	Unspecified
68 ~ 83	Serial Number	Serial Number	
84 ~ 89	yy/mm/dd	Date Code	
90 ~ 91	20,20	Vendor specific lot code	Unspecified
92	68	Diagnostic Monitoring Type	Internal calibration
93	B0	Enhanced Options (soft)	All flags, TX_FAULT, RX-LOS
94	03	SFF-8472 Compliance	Rev10.2
95		CC_EXT	Check sum of byte 64 ~ 94
96~127		Vendor specific	

Content in 2-Wire Address A2H

Add	Bytes	Name	Hex	Real Value
00-01	2	Temp High Alarm*	5500 (6400)	85°C (100°C)
02-03	2	Temp Low Alarm*	0000 (D800)	0°C (-40°C)
04-05	2	Temp High Warning*	5000 (5F00)	80°C (95°C)
06-07	2	Temp Low Warning*	0A00 (E200)	10°C (-30°C)
08-09	2	Voltage High Alarm	8CA0	3.6V
10-11	2	Voltage Low Alarm	7530	3.0V
12-13	2	Voltage High Warning	88B8	3.5V
14-15	2	Voltage Low Warning	7918	3.1V
16-17	2	Bias High Alarm	AFC8	90mA
18-19	2	Bias Low Alarm	09C4	5mA
20-21	2	Bias High Warning	9C40	80mA
22-23	2	Bias Low Warning	0DAC	7mA
24-25	2	TX Power High Alarm	0C5A	-5dBm
26-27	2	TX Power Low Alarm	00C8	-17dBm
28-29	2	TX Power High Warning	07CB	-7dBm
30-31	2	TX Power Low Warning	013C	-15dBm
32-33	2	RX Power High Alarm	03E8	-10dBm
34-35	2	RX Power Low Alarm	0004	-34dBm
36-37	2	RX Power High Warning	0277	-12dBm
38-39	2	RX Power Low Warning	0006	-32dBm
40-55	16	Reserved	00	-
56-59	4	RX_PWR(4)	00000000	0
60-63	4	RX_PWR(3)	00000000	0
64-67	4	RX_PWR(2)	00000000	0
68-71	4	RX_PWR(1)	3F800000	1
72-75	4	RX_PWR(0)	00000000	0
76-77	2	TX_I(Slope)	0100	1
78-79	2	TX_I(Offset)	0000	0
80-81	2	TX_PWR(Slope)	0100	1
82-83	2	TX_PWR(Offset)	0000	0
84-85	2	T(Slope)	0100	1
86-87	2	T(Offset)	0000	0
88-89	2	V(Slope)	0100	1
90-91	2	V(Offset)	0000	0
92-94	3	Reserved	00	-
95	1	Checksum		-

Note \*: ( ) for TBD-S2AC1-G11.

**Mechanical Outlines**

( Unit : mm)

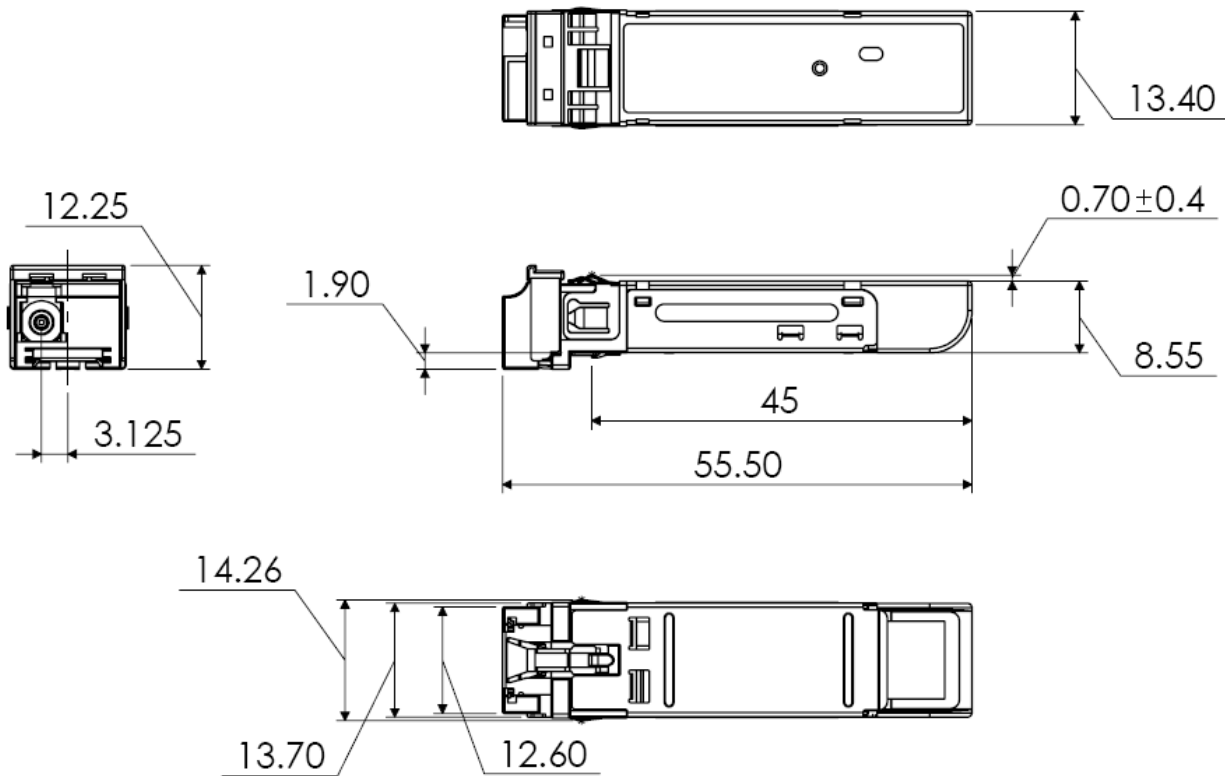



# Mouser Electronics

Authorized Distributor

Click to View Pricing, Inventory, Delivery & Lifecycle Information:

[Formerica:](#)

[TBD-S2AC1-G11](#) [TBD-S1AC1-G11](#)

## Данный компонент на территории Российской Федерации

### Вы можете приобрести в компании MosChip.

Для оперативного оформления запроса Вам необходимо перейти по данной ссылке:

<http://moschip.ru/get-element>

Вы можете разместить у нас заказ для любого Вашего проекта, будь то серийное производство или разработка единичного прибора.

В нашем ассортименте представлены ведущие мировые производители активных и пассивных электронных компонентов.

Нашей специализацией является поставка электронной компонентной базы двойного назначения, продукции таких производителей как XILINX, Intel (ex.ALTERA), Vicor, Microchip, Texas Instruments, Analog Devices, Mini-Circuits, Amphenol, Glenair.

Сотрудничество с глобальными дистрибьюторами электронных компонентов, предоставляет возможность заказывать и получать с международных складов практически любой перечень компонентов в оптимальные для Вас сроки.

На всех этапах разработки и производства наши партнеры могут получить квалифицированную поддержку опытных инженеров.

Система менеджмента качества компании отвечает требованиям в соответствии с ГОСТ Р ИСО 9001, ГОСТ РВ 0015-002 и ЭС РД 009

### Офис по работе с юридическими лицами:

105318, г.Москва, ул.Щербаковская д.3, офис 1107, 1118, ДЦ «Щербаковский»

Телефон: +7 495 668-12-70 (многоканальный)

Факс: +7 495 668-12-70 (доб.304)

E-mail: [info@moschip.ru](mailto:info@moschip.ru)

Skype отдела продаж:

moschip.ru

moschip.ru\_4

moschip.ru\_6

moschip.ru\_9