

## LOW NOISE 150mA LDO REGULATOR R1111N SERIES

### OUTLINE

The R1111N Series are voltage regulator ICs with high output voltage accuracy, extremely low supply current, low ON-resistance, and high Ripple Rejection by CMOS process. Each of these voltage regulator ICs consists of a voltage reference unit, an error amplifier, resistors, a current limit circuit, and a chip enable circuit.

These ICs perform with low dropout voltage and a chip enable function. The line transient response and load transient response of the R1111N Series are excellent, thus these ICs are very suitable for the power supply for hand-held communication equipment.

The output voltage of these ICs is fixed with high accuracy. Since the package for these ICs are SOT-23-5 (Mini-mold) package, high density mounting of the ICs on boards is possible.

### FEATURES

- Ultra-Low Supply Current.....TYP. 35 $\mu$ A
- Standby Mode .....TYP. 0.1 $\mu$ A
- Low Dropout Voltage .....TYP. 0.2V( $I_{OUT}=100mA$ )
- High Ripple Rejection .....TYP. 70dB( $f=1kHz$ )
- Low Temperature-Drift Coefficient of
- Output Voltage.....TYP.  $\pm 100ppm/^{\circ}C$
- Excellent Line Regulation .....TYP. 0.05%/V
- High Output Voltage Accuracy..... $\pm 2.0\%$
- Excellent Line Transient Response and Load Transient Response
- Small Package .....SOT-23-5(Mini-mold)
- Output Voltage.....Stepwise setting with a step of 0.1V in the range of 1.5V to 5.0V is possible
- Built-in chip enable circuit ( 2 types; A: "L" active, B: "H" active)
- Pinout .....Similar to the LP2980

### APPLICATIONS

- Power source for cellular phones such as GSM, CDMA and various kind of PCSs.
- Power source for electrical appliances such as cameras, VCRs and camcorders.
- Power source for battery-powered equipment.

### BLOCK DIAGRAM

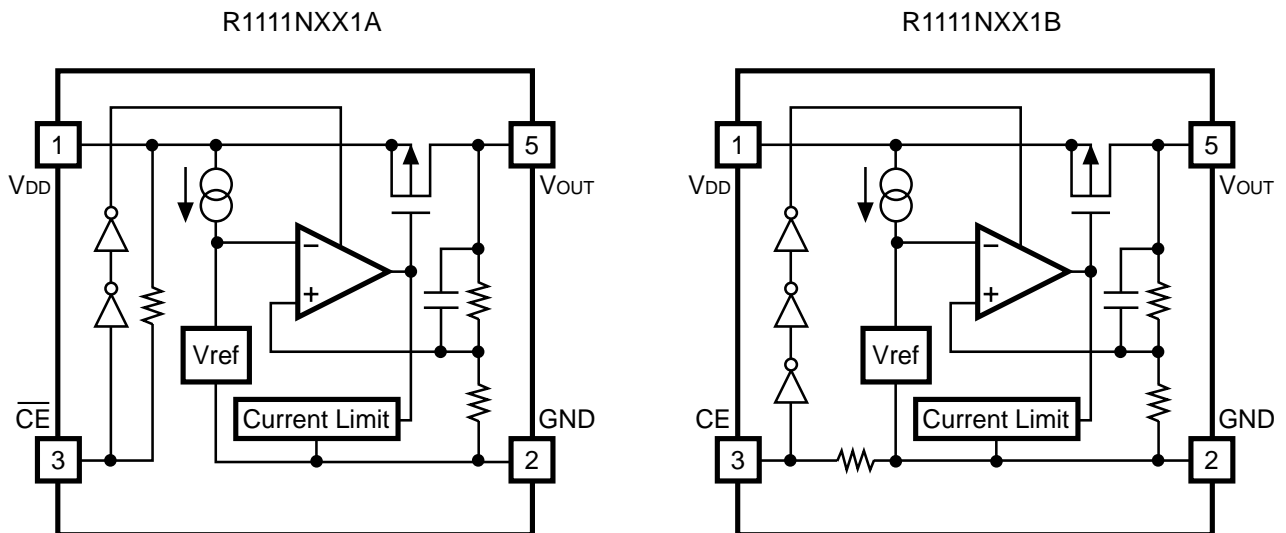

## SELECTION GUIDE

The output voltage, the active type, the packing type, and the taping type for the ICs can be selected at the user's request. The selection can be made by designating the part number as shown below :

R1111XXX1X-XX ←Part Number  
 ↑ ↑ ↑ ↑  
 a b c d

Code	Contents
a	Designation of Package Type : N:SOT-23-5 (Mini-mold)
b	Setting Output Voltage (V <sub>OUT</sub> ) : Stepwise setting with a step of 0.1V in the range of 1.5V to 5.0V is possible.
c	Designation of Active Type : A :“L” active type B :“H” active type
d	Designation of Taping Type : Ex. TR, TL (refer to Taping Specifications ;TR type is the standard direction.)

## PIN CONFIGURATION

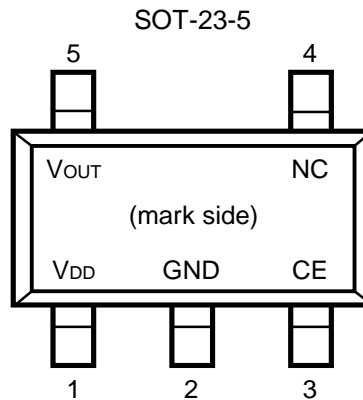

## PIN DESCRIPTION

Pin No.	Symbol	Description
1	V <sub>DD</sub>	Input Pin
2	GND	Ground Pin
3	$\overline{\text{CE}}$ or CE	Chip Enable Pin
4	NC	No Connection
5	V <sub>OUT</sub>	Output pin

## ■ ABSOLUTE MAXIMUM RATINGS

Item	Symbol	Rating	Unit
Input Voltage	$V_{IN}$	9	V
Input Voltage( $\overline{CE}$ or CE Pin)	$V_{CE}$	-0.3 ~ $V_{IN}+0.3$	V
Output Voltage	$V_{OUT}$	-0.3 ~ $V_{IN}+0.3$	V
Power Dissipation	$P_D$	250	mW
Operating Temperature Range	$T_{opt}$	-40 ~ 85	°C
Storage Temperature Range	$T_{stg}$	-55 ~ 125	°C

## ■ ELECTRICAL CHARACTERISTICS

### ● R1111NXX1A

$T_{opt}=25^{\circ}\text{C}$

Symbol	Item	Conditions	MIN.	TYP.	MAX.	Unit
$V_{OUT}$	Output Voltage	$V_{IN} = \text{Set } V_{OUT}+1\text{V}$ $1\text{mA} \leq I_{OUT} \leq 30\text{mA}$	$V_{OUT}$ $\times 0.98$		$V_{OUT}$ $\times 1.02$	V
$I_{OUT}$	Output Current	Refer to the ELECTRICAL CHARACTERISTICS by OUTPUT VOLTAGE				
$\Delta V_{OUT}/\Delta I_{OUT}$	Load Regulation	$V_{IN} = \text{Set } V_{OUT}+1\text{V}$ $1\text{mA} \leq I_{OUT} \leq 80\text{mA}$		12	40	mV
$V_{DIF}$	Dropout Voltage	Refer to the ELECTRICAL CHARACTERISTICS by OUTPUT VOLTAGE				
$I_{SS}$	Supply Current	$V_{IN} = \text{Set } V_{OUT}+1\text{V}$		35	70	$\mu\text{A}$
$I_{standby}$	Supply Current (Standby)	$V_{IN} = V_{CE} = \text{Set } V_{OUT}+1\text{V}$		0.1	1.0	$\mu\text{A}$
$\Delta V_{OUT}/\Delta V_{IN}$	Line Regulation	Set $V_{OUT}+0.5\text{V} \leq V_{IN} \leq 8\text{V}$ $I_{OUT} = 30\text{mA}$		0.05	0.20	%/V
RR	Ripple Rejection	$f = 1\text{KHz}$ , Ripple $0.5\text{Vp-p}$ $V_{IN} = \text{Set } V_{OUT}+1\text{V}$		70		dB
$V_{IN}$	Input Voltage				8	V
$\Delta V_{OUT}/\Delta T$	Output Voltage Temperature Coefficient	$I_{OUT} = 30\text{mA}$ $-40^{\circ}\text{C} \leq T_{opt} \leq 85^{\circ}\text{C}$		$\pm 100$		ppm/ °C
$I_{lim}$	Short Current Limit	$V_{OUT} = 0\text{V}$		50		mA
$R_{PU}$	$\overline{CE}$ Pull-up Resistance		2.5	5	10	$\text{M}\Omega$
$V_{CEH}$	$\overline{CE}$ Input Voltage "H"		1.5		$V_{IN}$	V
$V_{CEL}$	$\overline{CE}$ Input Voltage "L"		0		0.25	V
en	Output Noise	$\text{BW} = 10\text{Hz} \sim 100\text{kHz}$		30		$\mu\text{Vrms}$

● R1111NXX1B

Topt=25°C

Symbol	Item	Conditions	MIN.	TYP.	MAX.	Unit
V <sub>OUT</sub>	Output Voltage	V <sub>IN</sub> = Set V <sub>OUT</sub> +1V 1mA ≤ I <sub>OUT</sub> ≤ 30mA	V <sub>OUT</sub> ×0.98		V <sub>OUT</sub> ×1.02	V
I <sub>OUT</sub>	Output Current	Refer to the ELECTRICAL CHARACTERISTICS by OUTPUT VOLTAGE				
ΔV <sub>OUT</sub> /ΔI <sub>OUT</sub>	Load Regulation	V <sub>IN</sub> = Set V <sub>OUT</sub> +1V 1mA ≤ I <sub>OUT</sub> ≤ 80mA		12	40	mV
V <sub>DIF</sub>	Dropout Voltage	Refer to the ELECTRICAL CHARACTERISTICS by OUTPUT VOLTAGE				
I <sub>SS</sub>	Supply Current	V <sub>IN</sub> = Set V <sub>OUT</sub> +1V		35	70	μA
I <sub>standby</sub>	Supply Current (Standby)	V <sub>IN</sub> = Set V <sub>OUT</sub> +1V V <sub>CE</sub> =GND		0.1	1.0	μA
ΔV <sub>OUT</sub> /ΔV <sub>IN</sub>	Line Regulation	Set V <sub>OUT</sub> +0.5V ≤ V <sub>IN</sub> ≤ 8V I <sub>OUT</sub> = 30mA		0.05	0.20	%/V
RR	Ripple Rejection	f = 1KHz, Ripple 0.5Vp-p V <sub>IN</sub> = Set V <sub>OUT</sub> +1V		70		dB
V <sub>IN</sub>	Input Voltage				8	V
ΔV <sub>OUT</sub> /ΔT	Output Voltage Temperature Coefficient	I <sub>OUT</sub> = 30mA -40°C ≤ Top t ≤ 85°C		±100		ppm/°C
I <sub>lim</sub>	Short Current Limit	V <sub>OUT</sub> = 0V		50		mA
R <sub>PD</sub>	CE Pull-down Resistance		2.5	5	10	MΩ
V <sub>CEH</sub>	CE Input Voltage "H"		1.5		V <sub>IN</sub>	V
V <sub>CEL</sub>	CE Input Voltage "L"		0		0.25	V
en	Output Noise	BW = 10Hz ~ 100kHz		30		μVrms

● ELECTRICAL CHARACTERISTICS by OUTPUT VOLTAGE

Topt = 25°C

Output Voltage	Output Current	
	I <sub>OUT</sub> (mA)	
	Condition	MIN.
1.5 ≤ V <sub>OUT</sub> ≤ 1.7	V <sub>IN</sub> - V <sub>OUT</sub> = 1.0V	100
1.8 ≤ V <sub>OUT</sub> ≤ 5.0		150

Topt = 25°C

Output Voltage V <sub>OUT</sub> (V)	Dropout Voltage			
	V <sub>DIF</sub> (V)			
	Condition	MIN.	TYP.	MAX.
1.5	I <sub>OUT</sub> = 100mA	0.5		
1.6		0.4		
1.7		0.3		
1.8 ≤ V <sub>OUT</sub> ≤ 1.9			0.60	1.40
2.0 ≤ V <sub>OUT</sub> ≤ 2.4			0.35	0.70
2.5 ≤ V <sub>OUT</sub> ≤ 2.7			0.24	0.35
2.8 ≤ V <sub>OUT</sub> ≤ 3.3			0.20	0.30
3.4 ≤ V <sub>OUT</sub> ≤ 5.0			0.17	0.26

## ■ OPERATION



In these ICs, fluctuation of Output Voltage,  $V_{OUT}$  is detected by Feed-back Registers R1, R2, and the result is compared with a reference voltage by Error Amplifier, so that a constant voltage is output. A current limit circuit for Protection at short mode and a chip enable circuit are included.

■ TEST CIRCUITS

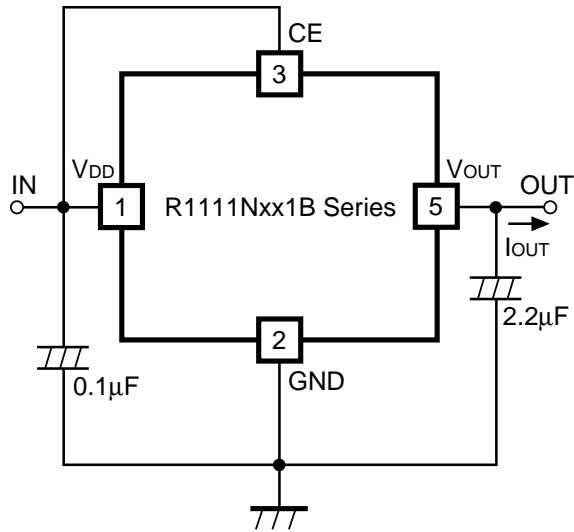

Fig.1 Standard test Circuit

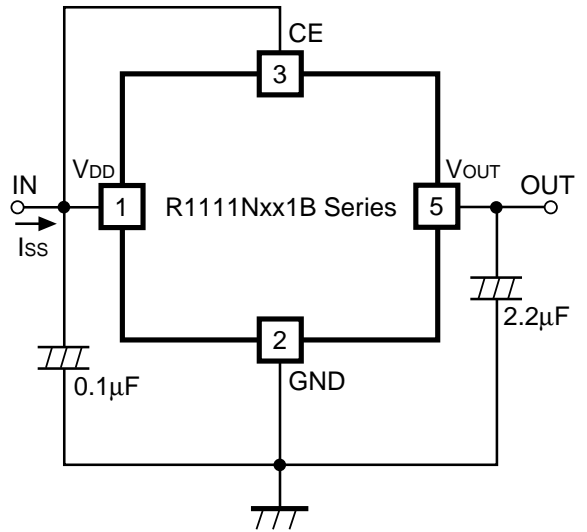

Fig.2 Supply Current Test Circuit

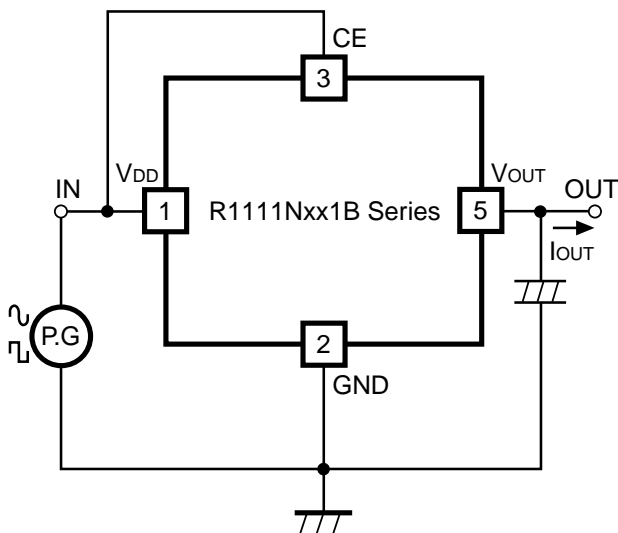

Fig.3 Ripple Rejection, Line Transient Response Test Circuit

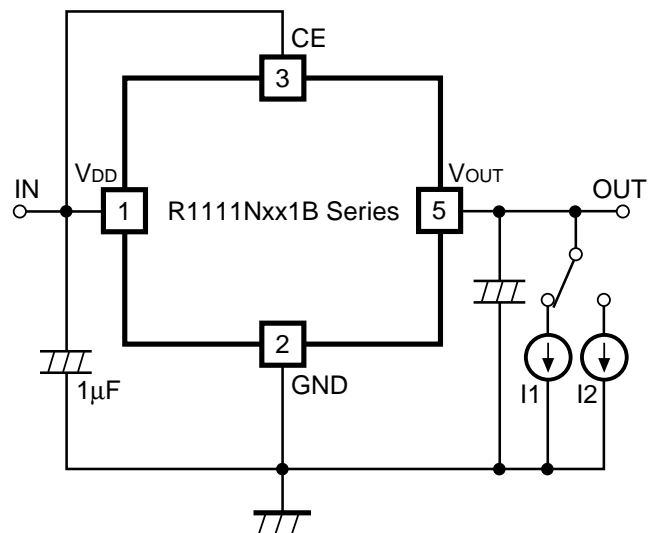
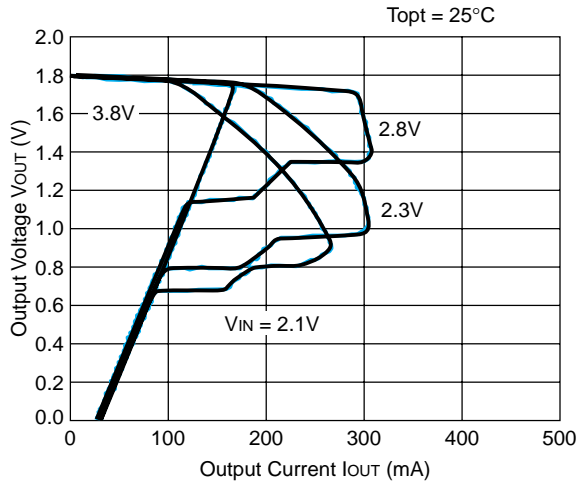

Fig.4 Load Transient Response Test Circuit

## TYPICAL CHARACTERISTICS

### 1) Output Voltage vs. Output Current

R1111N181B



R1111N301B

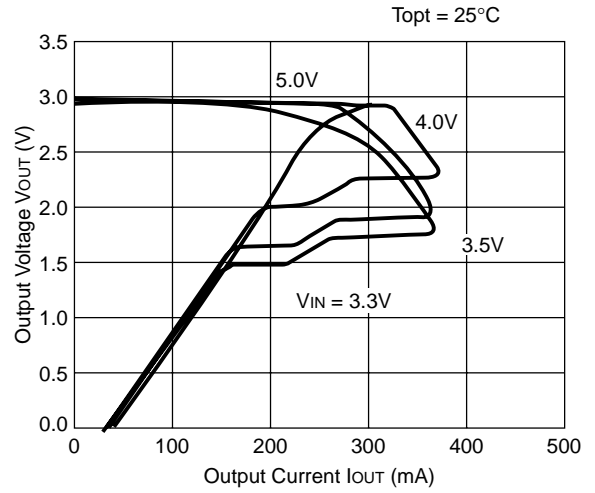

R1111N401B

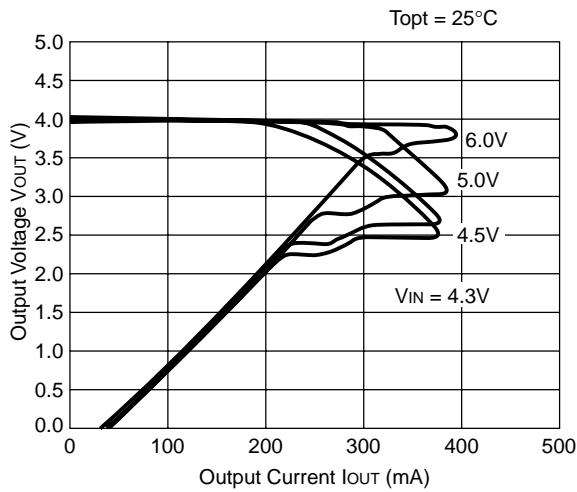

R1111N501B

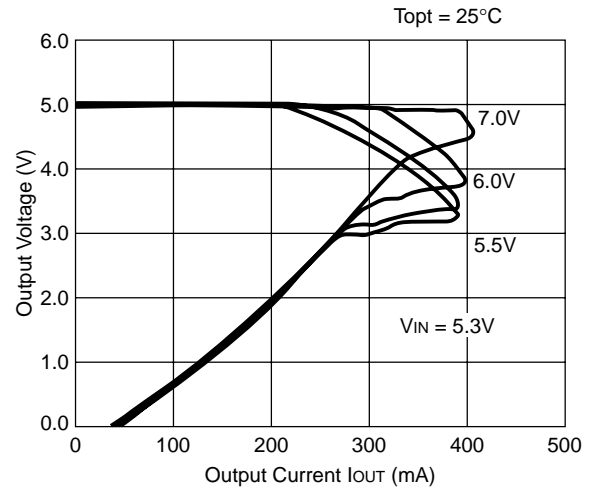

### 2) Output Voltage vs. Input Voltage

R1111N181B

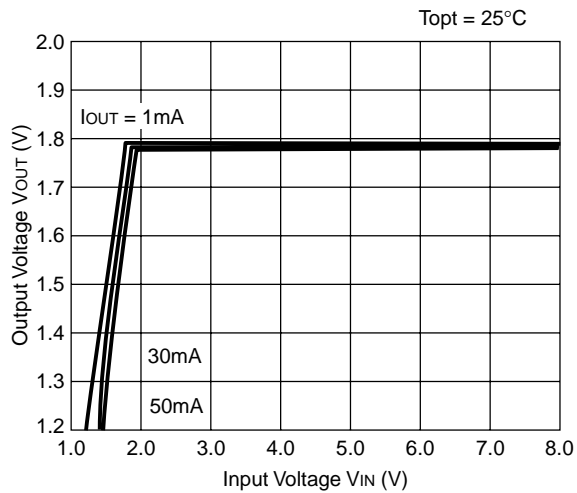

R1111N301B

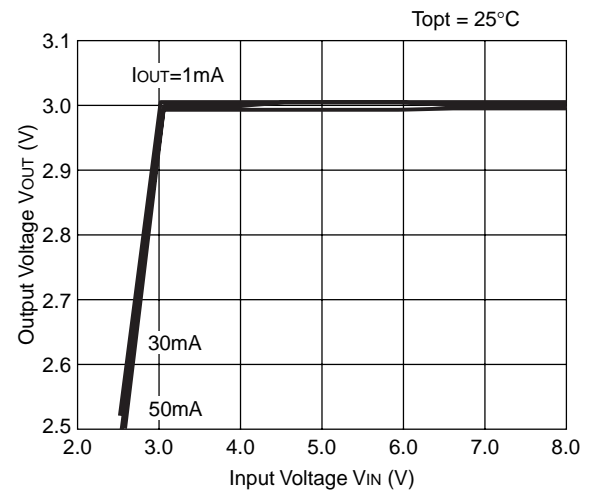



3) Dropout Voltage vs. Output Current

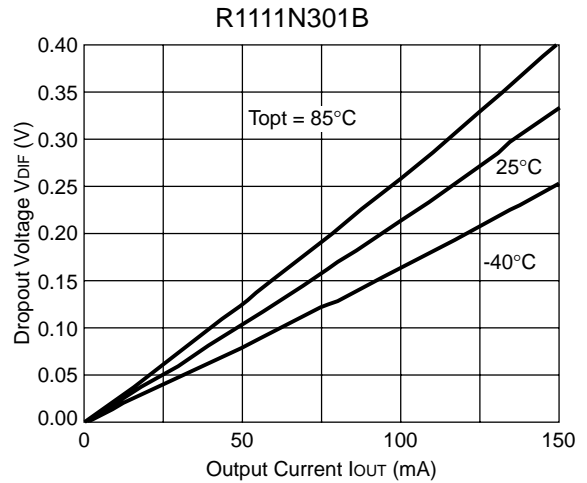
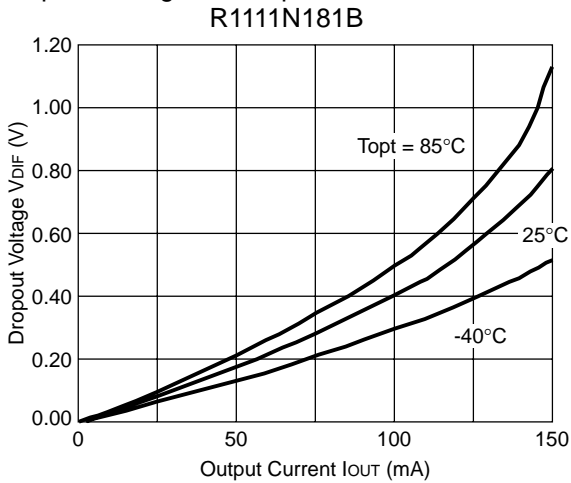



4) Output Voltage vs. Temperature  
R1111N181B



R1111N301B

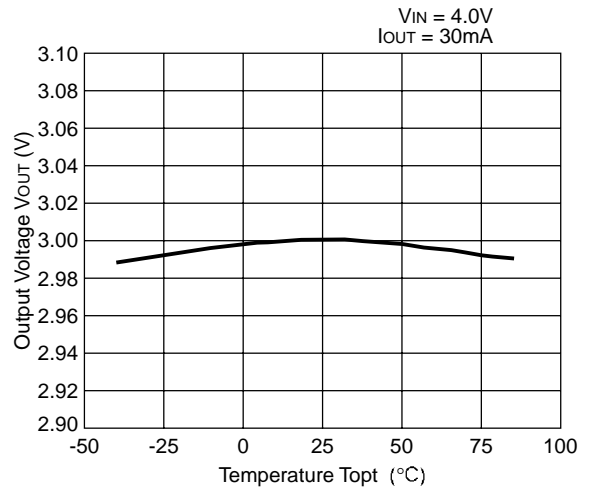

R1111N401B



R1111N501B

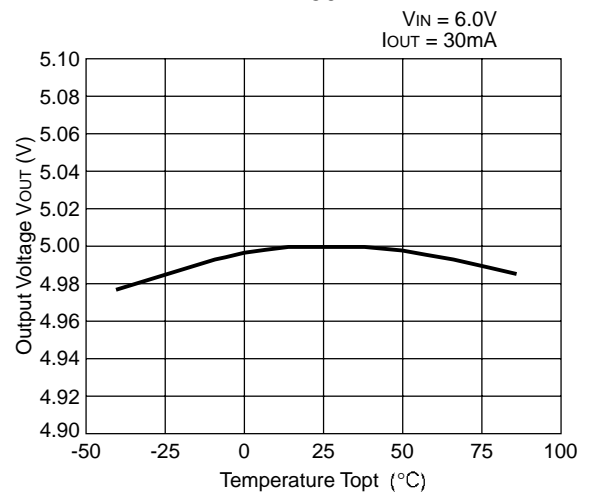

5) Supply Current vs. Input Voltage  
R1111N181B



R1111N301B

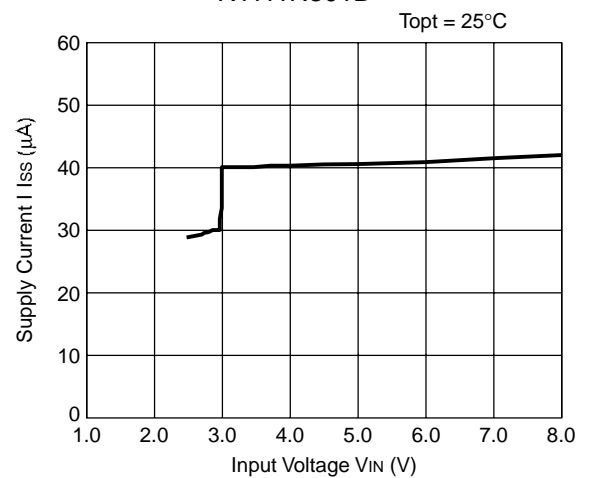

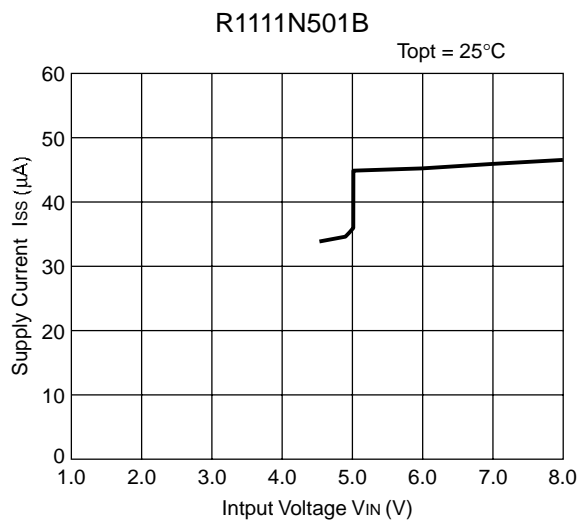
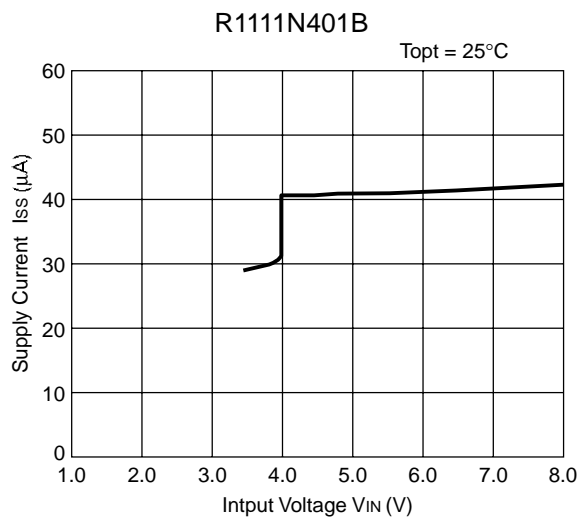

6) Supply Current vs. Temperature

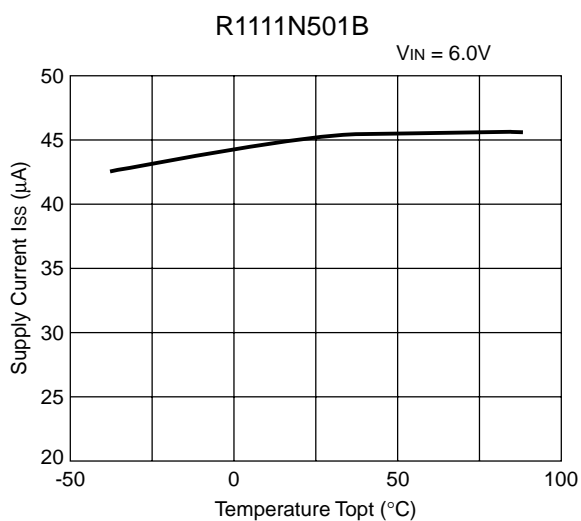
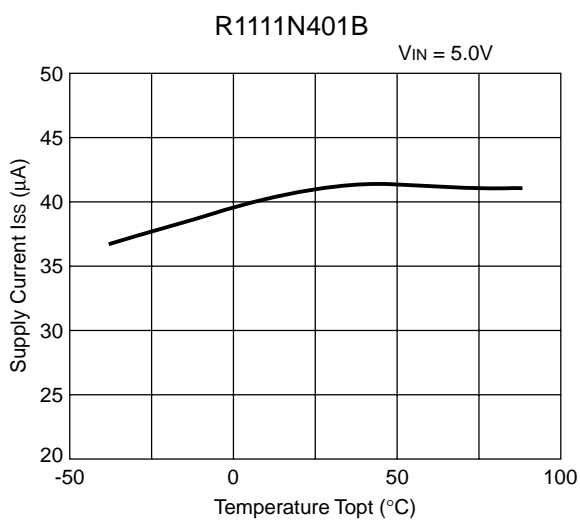
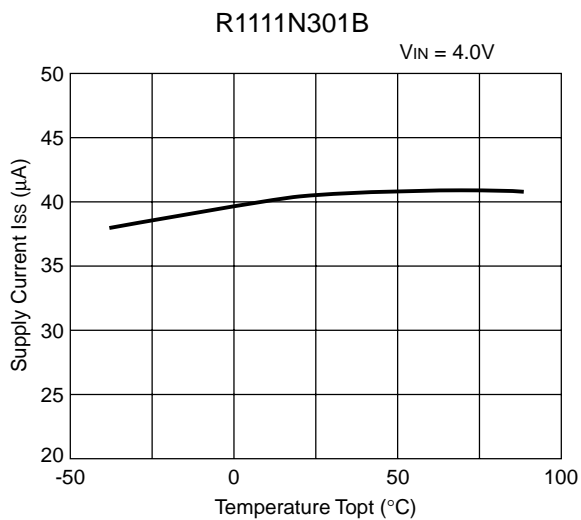
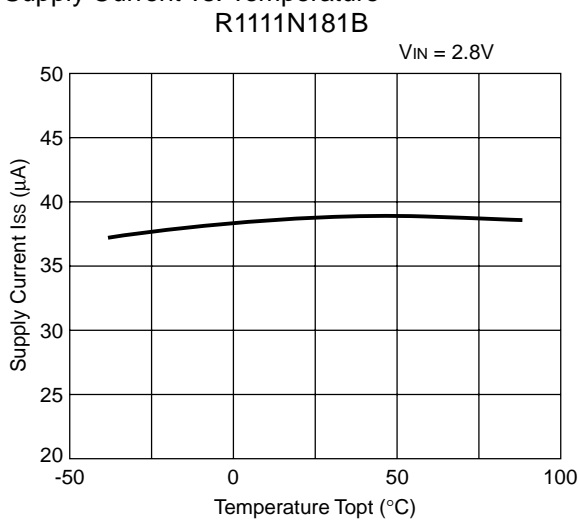

7) Dropout Voltage vs. Set Output Voltage  
R1111Nxx1B

Topt = 25 °C



8) Ripple Rejection vs. Frequency  
R1111N181B

VIN = 2.8VDC + 0.5Vp-p  
COUT = tantal 1.0μF



R1111N181B

VIN = 2.8VDC + 0.5Vp-p  
COUT = tantal 2.2μF



R1121N301B

VIN = 4VDC + 0.5Vp-p  
COUT = tantal 1.0μF



R1121N301B

VIN = 4VDC + 0.5Vp-p  
COUT = tantal 2.2μF



**R1111N401B**

$V_{IN} = 5.0V_{DC} + 0.5V_{p-p}$   
 $C_{OUT} = \text{tantal } 1.0\mu F$



**R1111N401B**

$V_{IN} = 5.0V_{DC} + 0.5V_{p-p}$   
 $C_{OUT} = \text{tantal } 2.2\mu F$



9) Ripple Rejection vs. Input Voltage (DC bias)

**R1111N301B**

$I_{OUT} = 1mA$   
 $C_{OUT} = 2.2\mu F$



**R1111N301B**

$I_{OUT} = 10mA$   
 $C_{OUT} = 2.2\mu F$



**R1111N301B**

$I_{OUT} = 50mA$   
 $C_{OUT} = 2.2\mu F$



10) Line Transient Response

R1111N301B

$I_{OUT}=30mA$   
 $t_r=t_f=5\mu s$   
 $C_{OUT}=\text{Tantalum } 1.0\mu F$

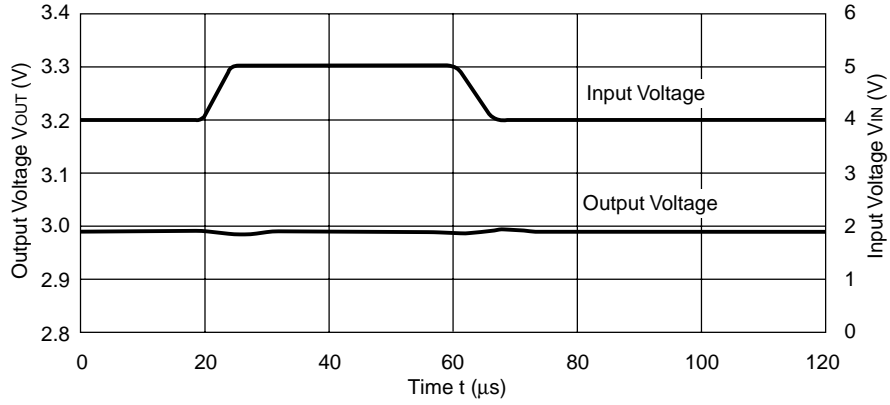

R1111N301B

$I_{OUT}=30mA$   
 $t_r=t_f=5\mu s$   
 $C_{OUT}=\text{Tantalum } 2.2\mu F$

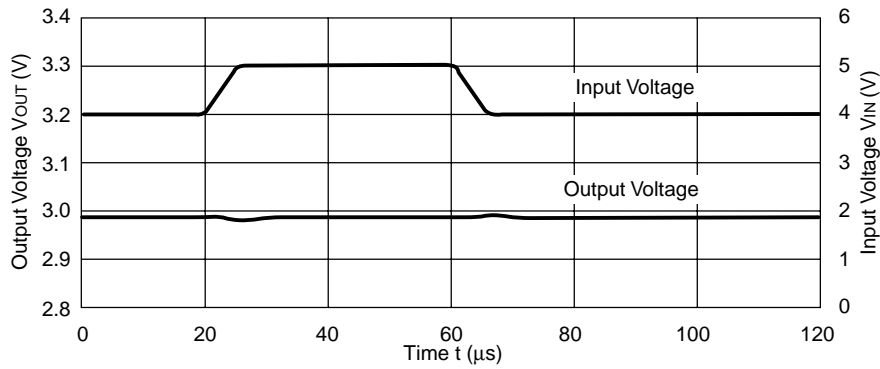

R1111N301B

$I_{OUT}=30mA$   
 $t_r=t_f=5\mu s$   
 $C_{OUT}=\text{Tantalum } 4.7\mu F$

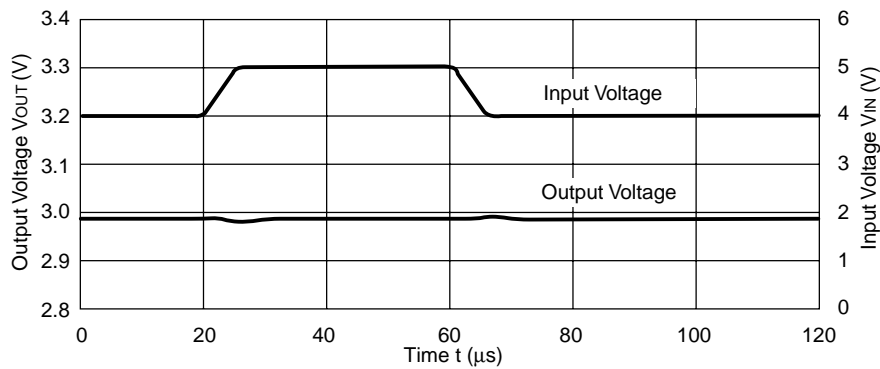

11) Load Transient Response

R1111N301B

$V_{IN}=4V$   
 $C_{IN}=\text{Tantalum } 1\mu F$   
 $C_{OUT}=\text{Tantalum } 1.0\mu F$



R1111N301B

$V_{IN}=4V$   
 $C_{IN}=\text{Tantalum } 1\mu F$   
 $C_{OUT}=\text{Tantalum } 2.2\mu F$



R1111N301B

$V_{IN}=4V$   
 $C_{IN}=\text{Tantalum } 1\mu F$   
 $C_{OUT}=\text{Tantalum } 4.7\mu F$



## TECHNICAL NOTES

When using these ICs, consider the following points:

In these ICs, phase compensation is made for securing stable operation even if the load current is varied. For this purpose, be sure to use a capacitor COUT with good frequency characteristics and ESR (Equivalent Series Resistance) of which is in the range described as follows:



Measuring Circuit for white noise;R1111N301B

The relations between  $I_{OUT}$  (Output Current) and ESR of Output Capacitor are shown below. The conditions when the white noise level is under  $40\mu V(Avg.)$  are marked as the hatched area in the graph.

(note: When the additional ceramic capacitors are connected to the Output Pin with Output capacitor for phase compensation, the operation might be unstable. Because of this, test these ICs with as same external components as ones to be used on the PCB.)

<measuring conditions>

- (1)  $V_{IN}=4V$
- (2) Frequency band :10Hz to 1MHz
- (3) Temperature :  $25^{\circ}C$

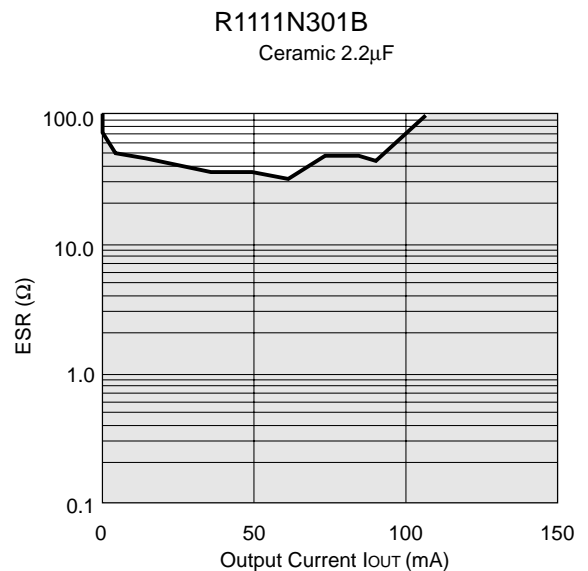

- Make  $V_{DD}$  and GND line sufficient. When the impedance of these is high, the noise might be picked up or not work correctly.
- Connect the capacitor with a capacitance of  $1\mu F$  or more between  $V_{DD}$  and GND as close as possible.
- Set external components, especially Output Capacitor, as close as possible to the ICs and make wiring shortest.

---

---

## ■ TYPICAL APPLICATION

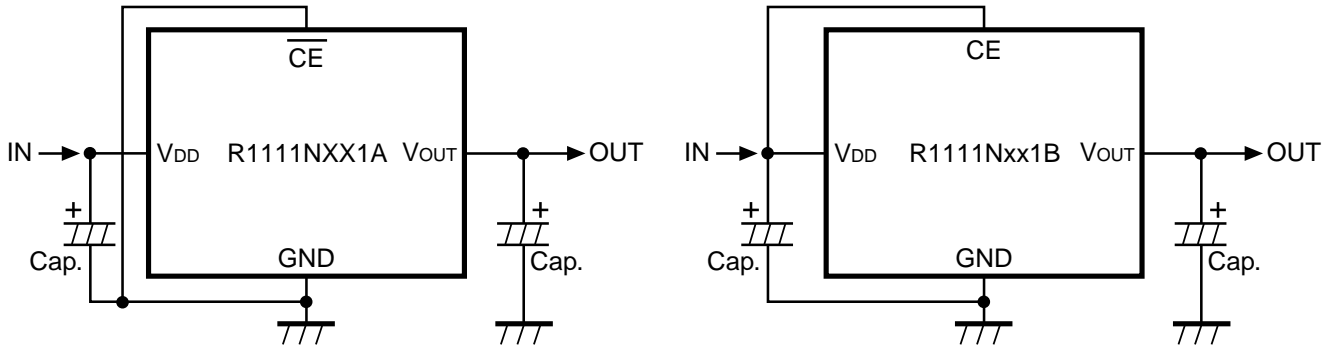



## Данный компонент на территории Российской Федерации

### Вы можете приобрести в компании MosChip.

Для оперативного оформления запроса Вам необходимо перейти по данной ссылке:

<http://moschip.ru/get-element>

Вы можете разместить у нас заказ для любого Вашего проекта, будь то серийное производство или разработка единичного прибора.

В нашем ассортименте представлены ведущие мировые производители активных и пассивных электронных компонентов.

Нашей специализацией является поставка электронной компонентной базы двойного назначения, продукции таких производителей как XILINX, Intel (ex.ALTERA), Vicor, Microchip, Texas Instruments, Analog Devices, Mini-Circuits, Amphenol, Glenair.

Сотрудничество с глобальными дистрибьюторами электронных компонентов, предоставляет возможность заказывать и получать с международных складов практически любой перечень компонентов в оптимальные для Вас сроки.

На всех этапах разработки и производства наши партнеры могут получить квалифицированную поддержку опытных инженеров.

Система менеджмента качества компании отвечает требованиям в соответствии с ГОСТ Р ИСО 9001, ГОСТ РВ 0015-002 и ЭС РД 009

### Офис по работе с юридическими лицами:

105318, г.Москва, ул.Щербаковская д.3, офис 1107, 1118, ДЦ «Щербаковский»

Телефон: +7 495 668-12-70 (многоканальный)

Факс: +7 495 668-12-70 (доб.304)

E-mail: [info@moschip.ru](mailto:info@moschip.ru)

Skype отдела продаж:

moschip.ru

moschip.ru\_4

moschip.ru\_6

moschip.ru\_9