

Features

- 802.11a + b/g Dual Band Applications
- Broadband Performance: DC - 6.0 GHz
- Low Insertion Loss: 0.75 dB @ 5.8 GHz
- High Isolation: 22 dB @ 5.8 GHz
- Fast Switching Speed: 0.5 μ m GaAs PHEMT
- Lead-Free 3 mm 12-Lead PQFN Package
- 100% Matte Tin Plating over Copper
- Halogen-Free "Green" Mold Compound
- 260°C Reflow Compatible
- RoHS* Compliant Version of MASWSS0070

Description

M/A-COM's MASWSS0202 is a broadband GaAs PHEMT MMIC SPDT switch in a lead-free 3 mm 12-lead PQFN package. The MASWSS0202 is ideally suited for applications where very small size and low cost are required.

Typical applications are for WLAN IEEE 802.11a and 802.11b/g PC cards and access points. Other applications include cordless phones and base stations. Designed for high power, this SPDT switch maintains high linearity up to 6.0 GHz.

The MASWSS0202 is fabricated using a 0.5 micron gate length GaAs PHEMT process. The process features full passivation for performance and reliability.

Ordering Information ¹

Part Number	Package
MASWSS0202TR-3000	3000 piece reel
MASWSS0202SMB	Sample Test Board (Includes 5 Samples)

1. Reference Application Note M513 for reel size information.

Functional Schematic

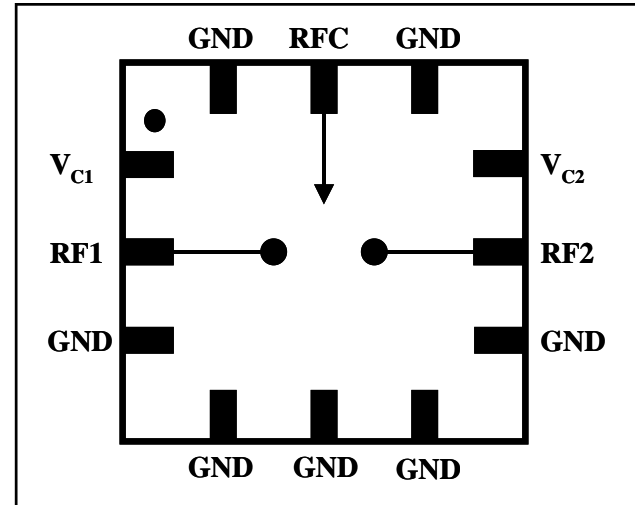

Pin Configuration ²

Pin No.	Pin Name	Description
1	V _{C1}	Control 1
2	RF1	RF Port
3	GND	Ground
4	GND	Ground
5	GND	Ground
6	GND	Ground
7	GND	Ground
8	RF2	RF Port
9	V _{C2}	Control 2
10	GND	Ground
11	RFC	RF Port
12	GND	Ground
13	Paddle ²	RF and DC Ground

2. The exposed pad centered on the package bottom must be connected to RF and DC ground.

* Restrictions on Hazardous Substances, European Union Directive 2002/95/EC.

GaAs Broadband SPDT Switch DC - 6.0 GHz

Rev. V1

Electrical Specifications: $T_A = 25^\circ\text{C}$, $Z_0 = 50 \Omega$, $V_C = 0 \text{ V} / 3 \text{ V}$, 8 pF Capacitor³

Parameter	Test Conditions	Units	Min.	Typ.	Max.
Insertion Loss ⁴	2 - 3 GHz	dB	—	0.55	0.9
	3 - 4 GHz	dB	—	0.55	0.9
	4 - 5 GHz	dB	—	0.65	1.0
	5 - 6 GHz	dB	—	0.75	1.1
Isolation	2 - 6 GHz	dB	22	25	—
Return Loss	DC - 6 GHz	dB	—	20	—
IIP2	Two Tone, +5 dBm / Tone, 5 MHz Spacing $V_C = 0.0 \text{ V} / 3 \text{ V} @ 2.4 \text{ GHz}$	dBm	—	91	—
	$V_C = 0.0 \text{ V} / 3 \text{ V} @ 5.8 \text{ GHz}$	dBm	—	81	—
	$V_C = 0.0 \text{ V} / 5 \text{ V} @ 2.4 \text{ GHz}$	dBm	—	99	—
	$V_C = 0.0 \text{ V} / 5 \text{ V} @ 5.8 \text{ GHz}$	dBm	—	91	—
IIP3	Two Tone, +5 dBm / Tone, 5 MHz Spacing $V_C = 0.0 \text{ V} / 3 \text{ V} @ 2.4 \text{ GHz}$	dBm	—	52	—
	$V_C = 0.0 \text{ V} / 3 \text{ V} @ 5.8 \text{ GHz}$	dBm	—	50	—
	$V_C = 0.0 \text{ V} / 5 \text{ V} @ 2.4 \text{ GHz}$	dBm	—	53	—
	$V_C = 0.0 \text{ V} / 5 \text{ V} @ 5.8 \text{ GHz}$	dBm	—	51	—
Input P-1dB	$V_C = 0.0 \text{ V} / 3 \text{ V} @ 2.4 \text{ GHz}$	dBm	—	32	—
	$V_C = 0.0 \text{ V} / 3 \text{ V} @ 5.8 \text{ GHz}$	dBm	—	29	—
	$V_C = 0.0 \text{ V} / 5 \text{ V} @ 2.4 \text{ GHz}$	dBm	—	37	—
	$V_C = 0.0 \text{ V} / 5 \text{ V} @ 5.8 \text{ GHz}$	dBm	—	35	—
2nd Harmonic	2.4 GHz, $P_{IN} = +20 \text{ dBm}$	dBc	—	-88	—
	5.3 GHz, $P_{IN} = +20 \text{ dBm}$	dBc	—	-91	—
	5.8 GHz, $P_{IN} = +20 \text{ dBm}$	dBc	—	-77	—
3rd Harmonic	2.4 GHz, $P_{IN} = +20 \text{ dBm}$	dBc	—	-87	—
	5.3 GHz, $P_{IN} = +20 \text{ dBm}$	dBc	—	-81	—
	5.8 GHz, $P_{IN} = +20 \text{ dBm}$	dBc	—	-85	—
T-rise, T-fall	10% to 90% RF and 90% to 10% RF	nS	—	13	—
Ton, Toff	50% control to 90% RF, 50% control to 10% RF	nS	—	35	—
Transients	—	mV	—	14	—
Control Current	$ V_C = 3 \text{ V}$	μA	—	10	25

3. For positive voltage control, external DC blocking capacitors are required on all RF ports.

4. Insertion loss can be optimized by varying the DC blocking capacitor value.

Truth Table⁵

Control V1	Control V2	RFC—RF1	RFC—RF2
1	0	On	Off
0	1	Off	On

5. 1 = +2.9 V to +5 V, 0 = 0 V \pm 0.2 V.

Absolute Maximum Ratings^{6,7}

Parameter	Absolute Maximum
Input Power @ 3 V Control	+32 dBm
Input Power @ 5 V Control	+34 dBm
Operating Voltage	+8.5 volts
Operating Temperature	-40°C to +85°C
Storage Temperature	-65°C to +150°C

6. Exceeding any one or combination of these limits may cause permanent damage to this device.

7. M/A-COM does not recommend sustained operation near these survivability limits.

ADVANCED: Data Sheets contain information regarding a product M/A-COM Technology Solutions is considering for development. Performance is based on target specifications, simulated results, and/or prototype measurements. Commitment to develop is not guaranteed.

PRELIMINARY: Data Sheets contain information regarding a product M/A-COM Technology Solutions has under development. Performance is based on engineering tests. Specifications are typical. Mechanical outline has been fixed. Engineering samples and/or test data may be available. Commitment to produce in volume is not guaranteed.

• **North America** Tel: 800.366.2266 / Fax: 978.366.2266

• **Europe** Tel: 44.1908.574.200 / Fax: 44.1908.574.300

• **Asia/Pacific** Tel: 81.44.844.8296 / Fax: 81.44.844.8298

Visit www.macomtech.com for additional data sheets and product information.

M/A-COM Technology Solutions Inc. and its affiliates reserve the right to make changes to the product(s) or information contained herein without notice.

Lead-Free 3 mm 12-Lead PQFN†

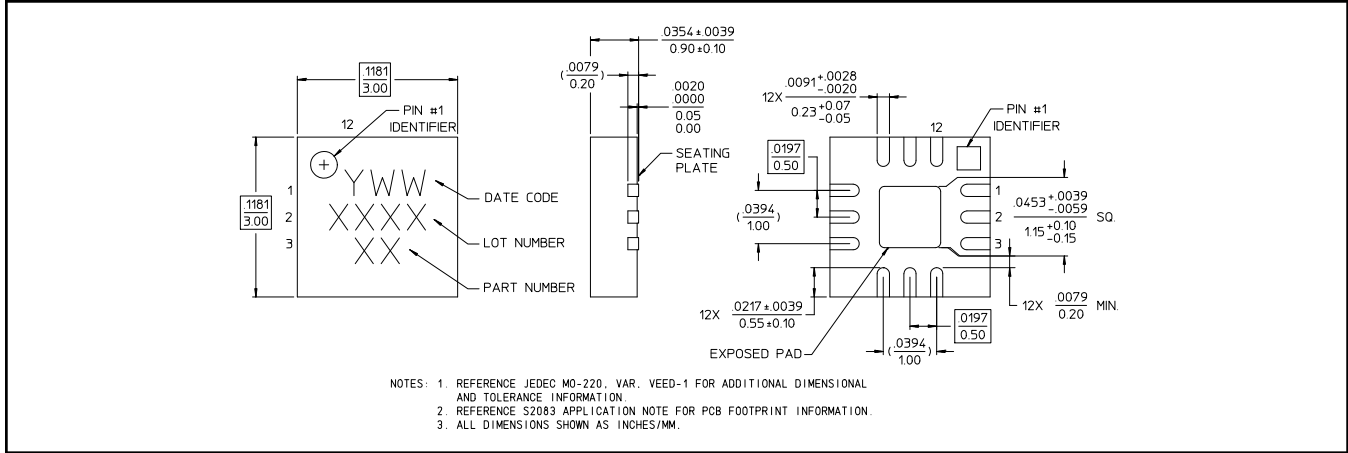

† Reference Application Note M538 for lead-free solder reflow recommendations.

Evaluation Board

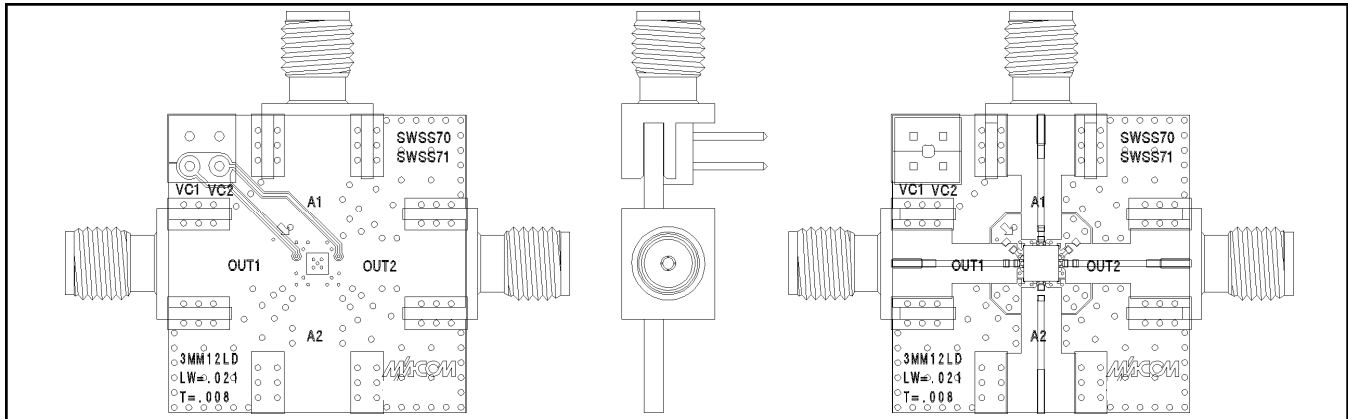

Application Schematic

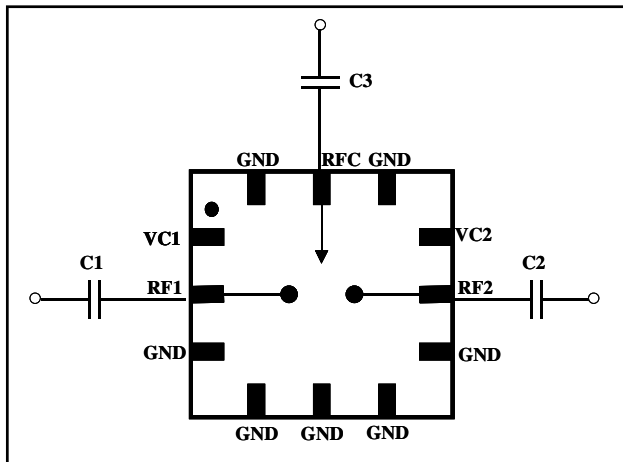

Application #1: Optimized for 802.11a (5-6 GHz)

Qty.	Description
3	Capacitor, 3.0 pF, 0402, SMT, 5% (C1-C3)

Application #2: Optimized for 802.11b/g (2.4 GHz)

Qty.	Description
3	Capacitor, 8.0 pF, 0402, SMT, 5% (C1-C3)

Typical Performance Curves with 0 / 3 V Control, 8 pF Capacitors

Insertion Loss

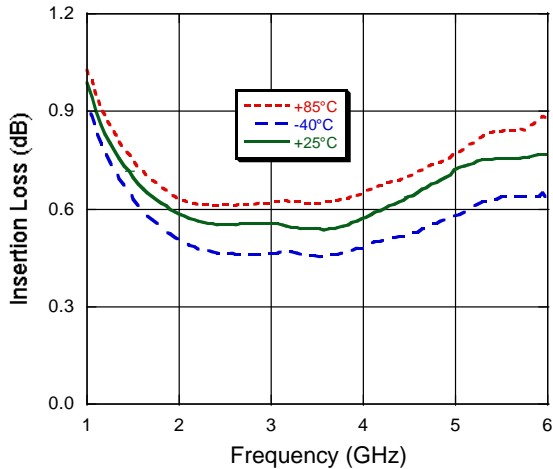

Isolation

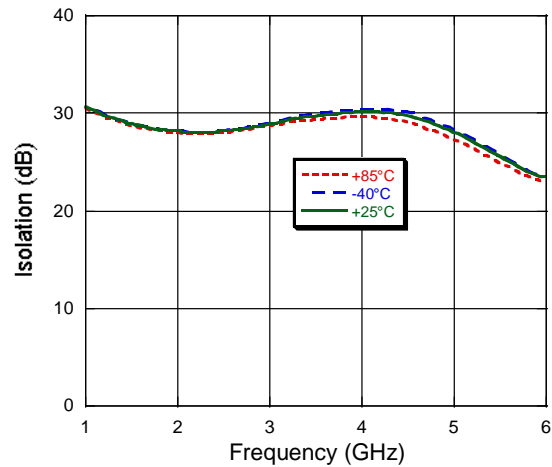

Return Loss

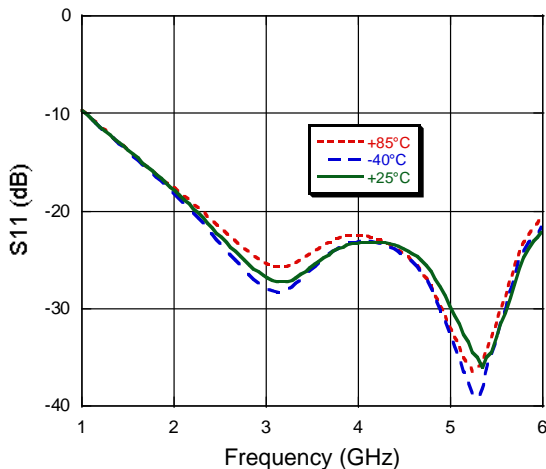

Qualification

Qualified to M/A-COM specification REL-201, Process Flow -2.

Handling Procedures

Please observe the following precautions to avoid damage:

Static Sensitivity

Gallium Arsenide Integrated Circuits are sensitive to electrostatic discharge (ESD) and can be damaged by static electricity. Proper ESD control techniques should be used when handling these devices.

Данный компонент на территории Российской Федерации

Вы можете приобрести в компании MosChip.

Для оперативного оформления запроса Вам необходимо перейти по данной ссылке:

<http://moschip.ru/get-element>

Вы можете разместить у нас заказ для любого Вашего проекта, будь то серийное производство или разработка единичного прибора.

В нашем ассортименте представлены ведущие мировые производители активных и пассивных электронных компонентов.

Нашей специализацией является поставка электронной компонентной базы двойного назначения, продукции таких производителей как XILINX, Intel (ex.ALTERA), Vicor, Microchip, Texas Instruments, Analog Devices, Mini-Circuits, Amphenol, Glenair.

Сотрудничество с глобальными дистрибьюторами электронных компонентов, предоставляет возможность заказывать и получать с международных складов практически любой перечень компонентов в оптимальные для Вас сроки.

На всех этапах разработки и производства наши партнеры могут получить квалифицированную поддержку опытных инженеров.

Система менеджмента качества компании отвечает требованиям в соответствии с ГОСТ Р ИСО 9001, ГОСТ РВ 0015-002 и ЭС РД 009

Офис по работе с юридическими лицами:

105318, г.Москва, ул.Щербаковская д.3, офис 1107, 1118, ДЦ «Щербаковский»

Телефон: +7 495 668-12-70 (многоканальный)

Факс: +7 495 668-12-70 (доб.304)

E-mail: info@moschip.ru

Skype отдела продаж:

moschip.ru

moschip.ru_4

moschip.ru_6

moschip.ru_9