

GaAs SP6T 2.5 V High Power Switch Dual- / Tri- / Quad-Band GSM Applications

Rev. V1

Features

- Dual- / tri- / quad-band GSM / GPRS / EDGE
- 2.5V Operation
- Harmonics: -70 dBc @ +34.5 dBm & 1 GHz
- Insertion Loss: 0.5 dB @ 1 GHz
- T_x - R_x Isolation: 41 dB @ 2 GHz
- Lead-Free 4 mm 20-Lead PQFN Package
- RoHS Compliant* and 260°C Reflow Compatible

Description

M/A-COM's MASW-000105 is a GaAs PHEMT MMIC single pole six throw (SP6T) high power switch in a 4 mm PQFN package. Designed for dual-, tri-, or quad-band GSM/GPRS/EDGE mobile devices, the MASW-000105 is ideally suited for applications where high power, low control voltage, low insertion loss, high isolation, small size and low cost are required. This part can be used in all systems operating up to 2.5 GHz requiring high power at low control voltage.

The MASW-000105 is fabricated using a 0.5 micron gate length GaAs PHEMT process. The process features full passivation for performance and reliability.

The MASW-000105 can also be purchased in die form as the MASWSS0091.

Functional Block Diagram

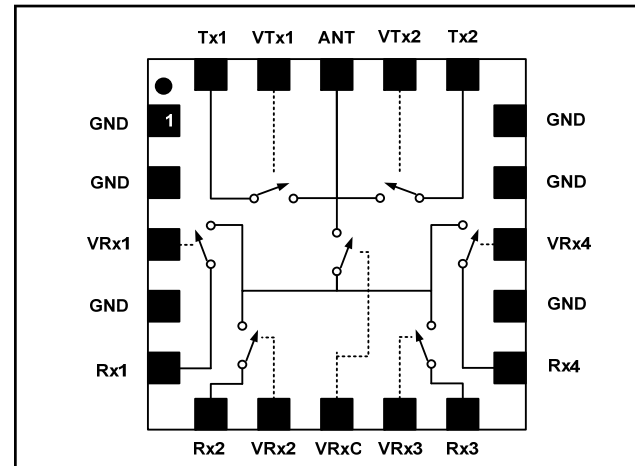

Pin Configuration

Pin No.	Function	Description
1	GND	Ground
2	GND	Ground
3	VRx1	Rx1 Control
4	GND	Ground
5	Rx1	Rx1 Port
6	Rx2	Rx2 Port
7	VRx2	Rx2 Control
8	VRxC	Rx Common Control
9	VRx3	Rx3 Control
10	Rx3	Rx3 Port
11	Rx4	Rx4 Port
12	GND	Ground
13	VRx4	Rx4 Control
14	GND	Ground
15	GND	Ground
16	Tx2	Tx2 Port
17	VTx2	Tx2 Control
18	ANT	ANT Pad
19	VTx1	Tx1 Control
20	Tx1	Tx1 Port
21	Paddle ³	RF and DC Ground

3. The exposed pad centered on the package bottom must be connected to RF and DC ground.

Ordering Information ^{1,2}

Part Number	Package
MASW-000105-TR3000	3000 piece reel
MASW-000105-001SMB	Sample Test Board

1. Reference Application Note M513 for reel size information.
2. All sample boards include 5 loose parts.

* Restrictions on Hazardous Substances, European Union Directive 2002/95/EC.

ADVANCED: Data Sheets contain information regarding a product M/A-COM Technology Solutions is considering for development. Performance is based on target specifications, simulated results, and/or prototype measurements. Commitment to develop is not guaranteed.
PRELIMINARY: Data Sheets contain information regarding a product M/A-COM Technology Solutions has under development. Performance is based on engineering tests. Specifications are typical. Mechanical outline has been fixed. Engineering samples and/or test data may be available. Commitment to produce in volume is not guaranteed.

• **North America** Tel: 800.366.2266 / Fax: 978.366.2266
 • **Europe** Tel: 44.1908.574.200 / Fax: 44.1908.574.300
 • **Asia/Pacific** Tel: 81.44.844.8296 / Fax: 81.44.844.8298
 Visit www.macomtech.com for additional data sheets and product information.

M/A-COM Technology Solutions Inc. and its affiliates reserve the right to make changes to the product(s) or information contained herein without notice.

GaAs SP6T 2.5 V High Power Switch Dual- / Tri- / Quad-Band GSM Applications

Rev. V1

Electrical Specifications: $T_A = 25^\circ\text{C}$, $V_C = 0\text{V}/2.5\text{V}$, $Z_0 = 50 \Omega$ ⁴

Parameter	Test Conditions	Units	Min.	Typ.	Max.
Insertion Loss ⁵	Ant - T _X 0.5 - 1.0 GHz 1.0 - 2.0 GHz	dB	- -	0.5 0.7	0.7 -
	Ant - R _X 0.5 - 1.0 GHz 1.0 - 2.0 GHz	dB	- -	1.0 1.3	1.2 -
Isolation	T _X to R _X , T _X On 0.5 - 1.0 GHz 1.0 - 2.0 GHz	dB	40 -	47 41	- -
	T _X to T _X , T _X On 0.5 - 1.0 GHz 1.0 - 2.0 GHz	dB	20 -	27 21	- -
	R _X to T _X , R _X On 0.5 - 1.0 GHz 1.0 - 2.0 GHz	dB	- -	26 21	- -
	R _X to R _X , R _X On 0.5 - 1.0 GHz 1.0 - 2.0 GHz	dB	- -	37 33	- -
Return Loss	0.5 - 1.0 GHz 1.0 - 2.0 GHz	dB	- -	18 16	- -
T _X P0.1dB	$V_C = 0 \text{ V} / 2.5 \text{ V}$	dBm	-	36	-
R _X P1dB	$V_C = 0 \text{ V} / 2.5 \text{ V}$	dBm	-	24	-
IP3	T _X to ANT	dBm	-	60	-
	ANT to R _X	dBm	-	50	-
2nd Harmonic	0.5 - 1.0 GHz 1.0 - 2.0 GHz	dBc	- -	71 70	- -
3rd Harmonic	0.5 - 1.0 GHz 1.0 - 2.0 GHz	dBc	- -	74 66	- -
Trise, Tfall	10% to 90% RF, 90% to 10% RF	μs	-	0.5	-
Ton, Toff	50% control to 90% RF, 50% control to 10% RF	μs	-	0.9	-
Transients	In Band	mV	-	30	-
Control Current	$ V_C = 2.5 \text{ V}$	μA	-	20	50

4. External DC blocking capacitors are required on all RF ports.

5. Insertion loss can be optimized by varying the DC blocking capacitor value, e.g. 100 pF for 0.5 GHz - 2.0 GHz.

GaAs SP6T 2.5 V High Power Switch Dual- / Tri- / Quad-Band GSM Applications

Rev. V1

Absolute Maximum Ratings ^{6,7}

Parameter	Absolute Maximum
Input Power (0.5 - 2.5 GHz, 2.5V Control)	+38 dBm
Voltage	+8.5 volts
Operating Temperature	-40°C to +85°C
Storage Temperature	-65°C to +150°C

- Exceeding any one or combination of these limits may cause permanent damage to this device.
- M/A-COM does not recommend sustained operation near these survivability limits.

Functional Schematic

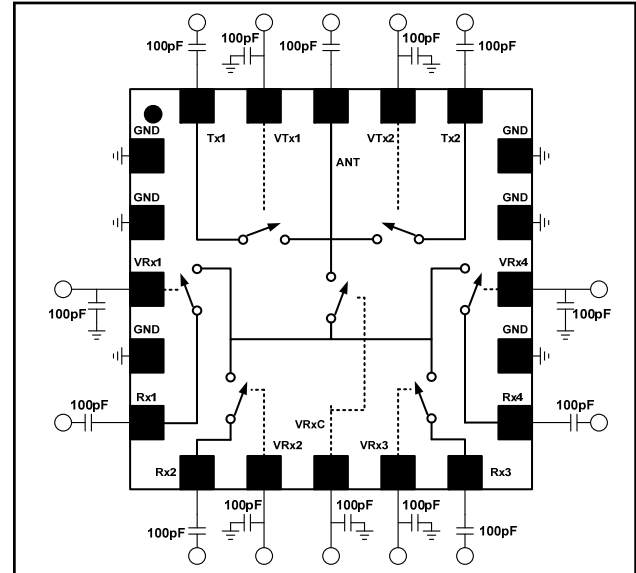

Truth Table ^{8,9}

VTx1	VTx2	VRxC	VRx1	VRx2	VRx3	VRx4	ANT-Tx1	ANT-Tx2	ANT-Rx1	ANT-Rx2	ANT-Rx3	ANT-Rx4
1	0	0	0	0	0	0	On	Off	Off	Off	Off	Off
0	1	0	0	0	0	0	Off	On	Off	Off	Off	Off
0	0	1	1	0	0	0	Off	Off	On	Off	Off	Off
0	0	1	0	1	0	0	Off	Off	Off	On	Off	Off
0	0	1	0	0	1	0	Off	Off	Off	Off	On	Off
0	0	1	0	0	0	1	Off	Off	Off	Off	Off	On

- Differential voltage, V (state 1) - V (state 0), must be 2.5 V minimum.
- State 0 = 0 V to +0.2 V, State 1 = 2.5 V to 5 V.

Typical Performance Curves

T_X Insertion Loss

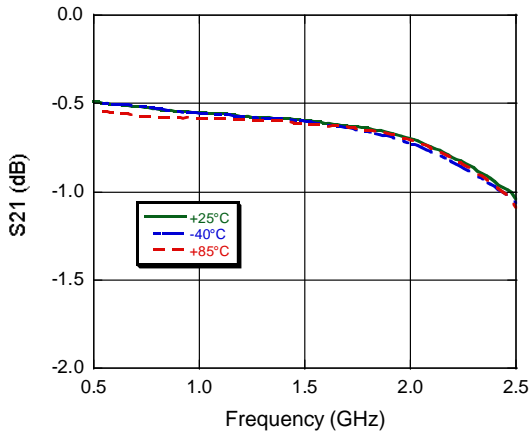

R_X Insertion Loss

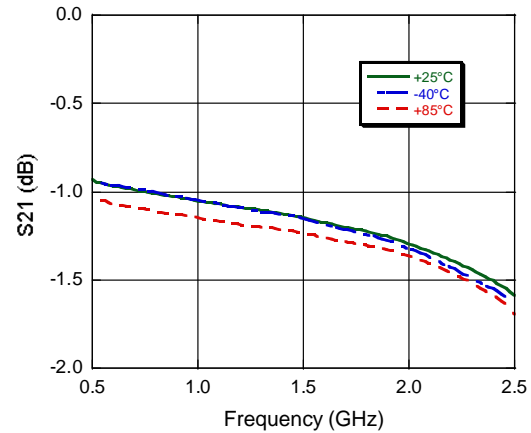

$T_X - T_X$ Isolation

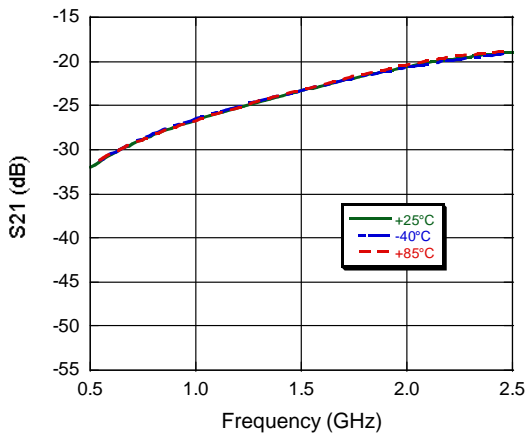

$T_X - R_X$ Isolation

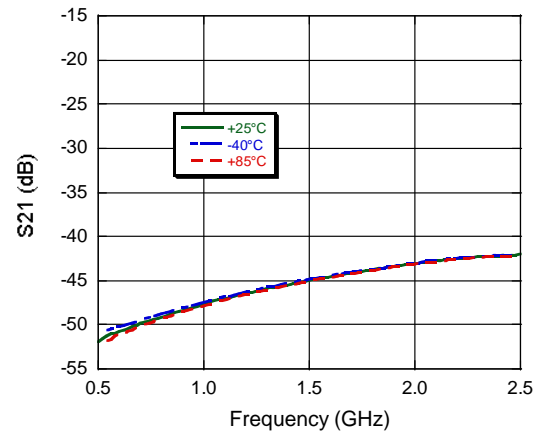

$R_X - T_X$ Isolation

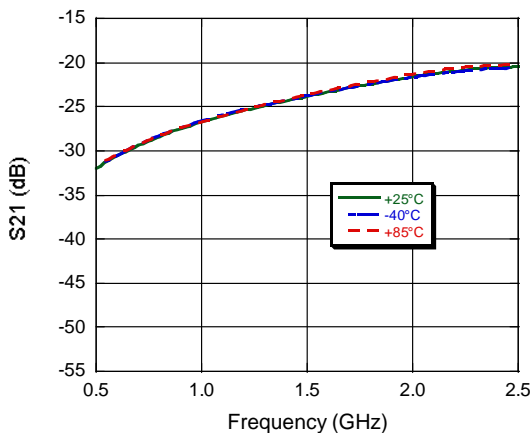

$R_X - R_X$ Isolation

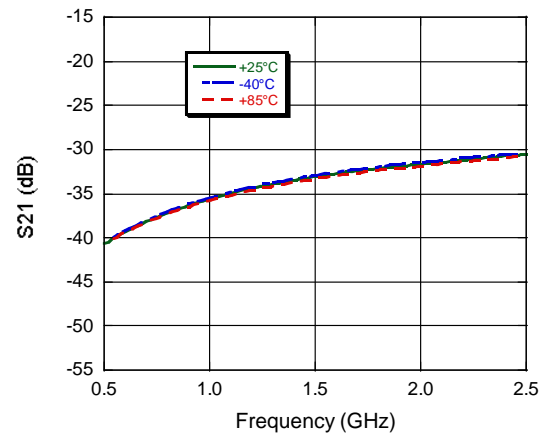

GaAs SP6T 2.5 V High Power Switch Dual- / Tri- / Quad-Band GSM Applications

Rev. V1

Typical Performance Curves

3rd Harmonic vs. V_{ctrl} @ 1 GHz, $P_{in} = +35$ dBm, 100% Duty Cycle

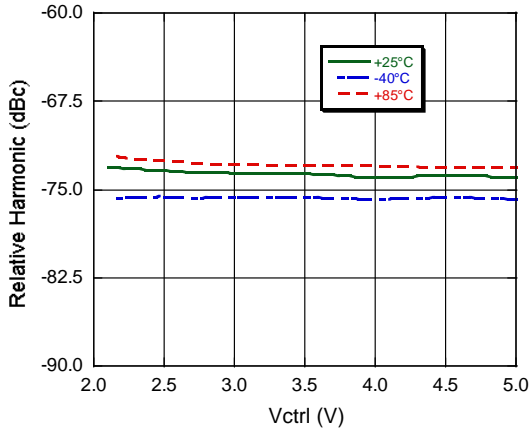

Qualification

Qualified to M/A-COM specification REL-201, Process Flow -2.

Handling Procedures

Please observe the following precautions to avoid damage:

Static Sensitivity

Gallium Arsenide Integrated Circuits are sensitive to electrostatic discharge (ESD) and can be damaged by static electricity. Proper ESD control techniques should be used when handling these devices.

Lead Free 4 mm 20-lead PQFN †

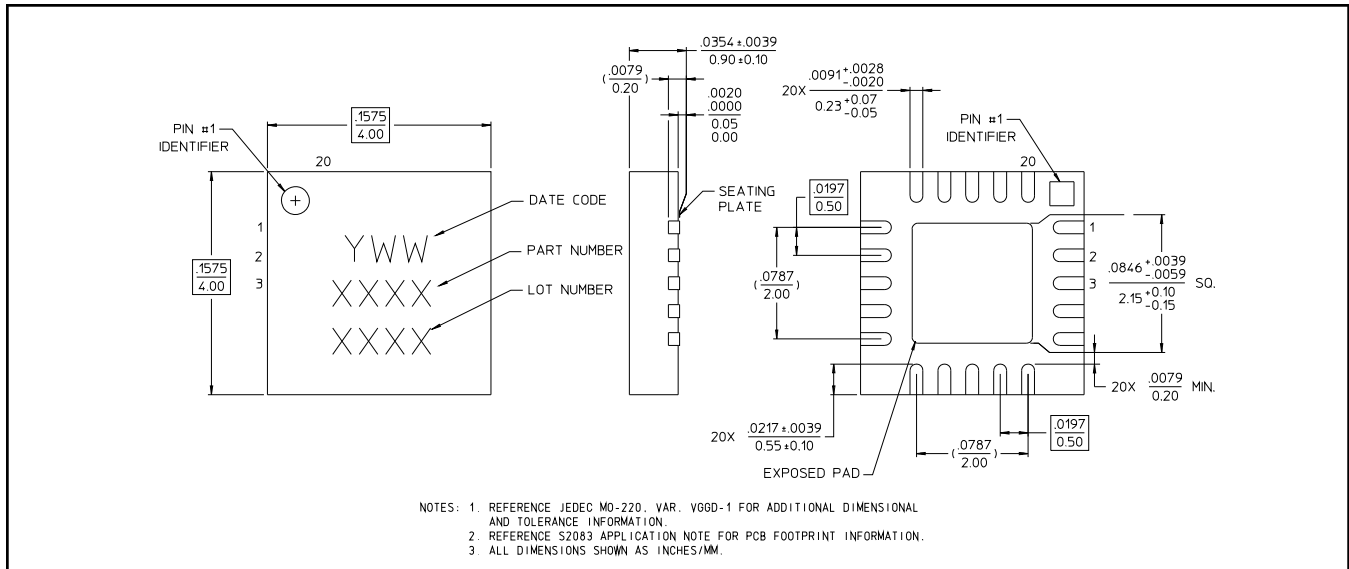

† Reference Application Note S2083 for lead-free solder reflow recommendations.
Meets JEDEC moisture sensitivity level 1 requirements.
Plating is 100% matte tin over copper.

Данный компонент на территории Российской Федерации

Вы можете приобрести в компании MosChip.

Для оперативного оформления запроса Вам необходимо перейти по данной ссылке:

<http://moschip.ru/get-element>

Вы можете разместить у нас заказ для любого Вашего проекта, будь то серийное производство или разработка единичного прибора.

В нашем ассортименте представлены ведущие мировые производители активных и пассивных электронных компонентов.

Нашей специализацией является поставка электронной компонентной базы двойного назначения, продукции таких производителей как XILINX, Intel (ex.ALTERA), Vicor, Microchip, Texas Instruments, Analog Devices, Mini-Circuits, Amphenol, Glenair.

Сотрудничество с глобальными дистрибьюторами электронных компонентов, предоставляет возможность заказывать и получать с международных складов практически любой перечень компонентов в оптимальные для Вас сроки.

На всех этапах разработки и производства наши партнеры могут получить квалифицированную поддержку опытных инженеров.

Система менеджмента качества компании отвечает требованиям в соответствии с ГОСТ Р ИСО 9001, ГОСТ РВ 0015-002 и ЭС РД 009

Офис по работе с юридическими лицами:

105318, г.Москва, ул.Щербаковская д.3, офис 1107, 1118, ДЦ «Щербаковский»

Телефон: +7 495 668-12-70 (многоканальный)

Факс: +7 495 668-12-70 (доб.304)

E-mail: info@moschip.ru

Skype отдела продаж:

moschip.ru

moschip.ru_4

moschip.ru_6

moschip.ru_9