

Quad high-side smart power solid-state relay

Datasheet - production data

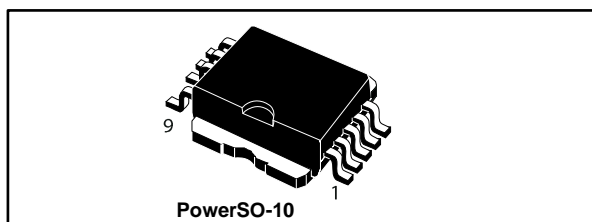

- Open drain diagnostic output
- Fast demagnetization of inductive loads
- Conforms to IEC 61131-2

Description

The VN340SP-33-E is a monolithic device developed using STMicroelectronics' VIPower technology, intended to drive four independent resistive or inductive loads with one side connected to ground. Active current limitation prevents dropping of the system power supply in case of shorted load. Built-in thermal shutdown protects the chip from overtemperature and short-circuit. The open drain diagnostic output indicates overtemperature conditions. Each I/O is pulled down when the overtemperature condition of the relative channel is verified.

Features

Type	$V_{\text{demag}}^{(1)}$	$R_{\text{DS(on)}}^{(1)}$	$I_{\text{OUT}}^{(1)}$	V_{CC}
VN340SP-33-E	$V_{\text{CC}}-55\text{ V}$	$0.2\ \Omega$	1 A	36 V

Notes:

⁽¹⁾Per channel

- Output current: 1 A per channel
- Digital I/O clamped at 32 V minimum voltage
- Shorted load and overtemperature protections
- Protection against loss of ground
- Built-in current limiter
- Undervoltage shutdown

Table 1: Device summary

Order code	Package	Packing
VN340SP-33-E	PowerSO-10	Tube
VN340SPTR-33-E		Tape and reel

Contents

1	Block diagram.....	5
2	Pin connection.....	6
3	Maximum ratings	7
4	Electrical characteristics	8
5	Test circuits	10
6	Switching time waveforms and truth table	12
7	Package information	14
	7.1 PowerSO-10 package information	14
	7.2 PowerSO-10 packing information.....	16
8	Revision history	18

List of tables

Table 1: Device summary	1
Table 2: Absolute maximum ratings	7
Table 3: Thermal data.....	7
Table 4: Power section	8
Table 5: Switching ($V_{CC} = 24\text{ V}$, $T_J = 25\text{ }^\circ\text{C}$)	8
Table 6: Logic inputs.....	9
Table 7: Protection and diagnostic	9
Table 8: Truth table.....	13
Table 9: PowerSO-10 package mechanical data	15
Table 10: PowerSO-10 carrier tape dimension mechanical data	16
Table 11: PowerSO-10 reel dimension mechanical data	17
Table 12: PowerSO-10 base and bulk quantity	17
Table 13: Document revision history	18

List of figures

Figure 1: Block diagram	5
Figure 2: Connection diagram (top view)	6
Figure 3: Current and voltage conventions	6
Figure 4: Avalanche energy test circuit	10
Figure 5: Peak short-circuit test diagram	10
Figure 6: I_{LGND} test configuration	11
Figure 7: Switching waveforms	12
Figure 8: Switching parameter test conditions	12
Figure 9: Driving circuit	13
Figure 10: PowerSO-10 package outline	14
Figure 11: PowerSO-10 carrier tape outline	16
Figure 12: PowerSO-10 reel outline	17

1 Block diagram

Figure 1: Block diagram

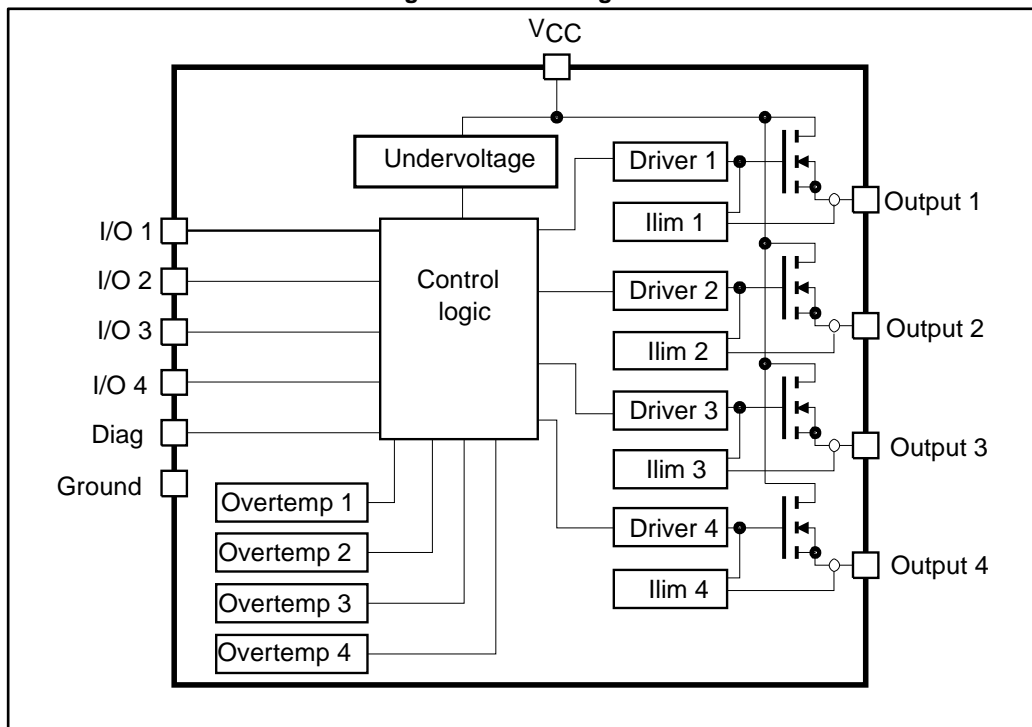

2 Pin connection

Figure 2: Connection diagram (top view)

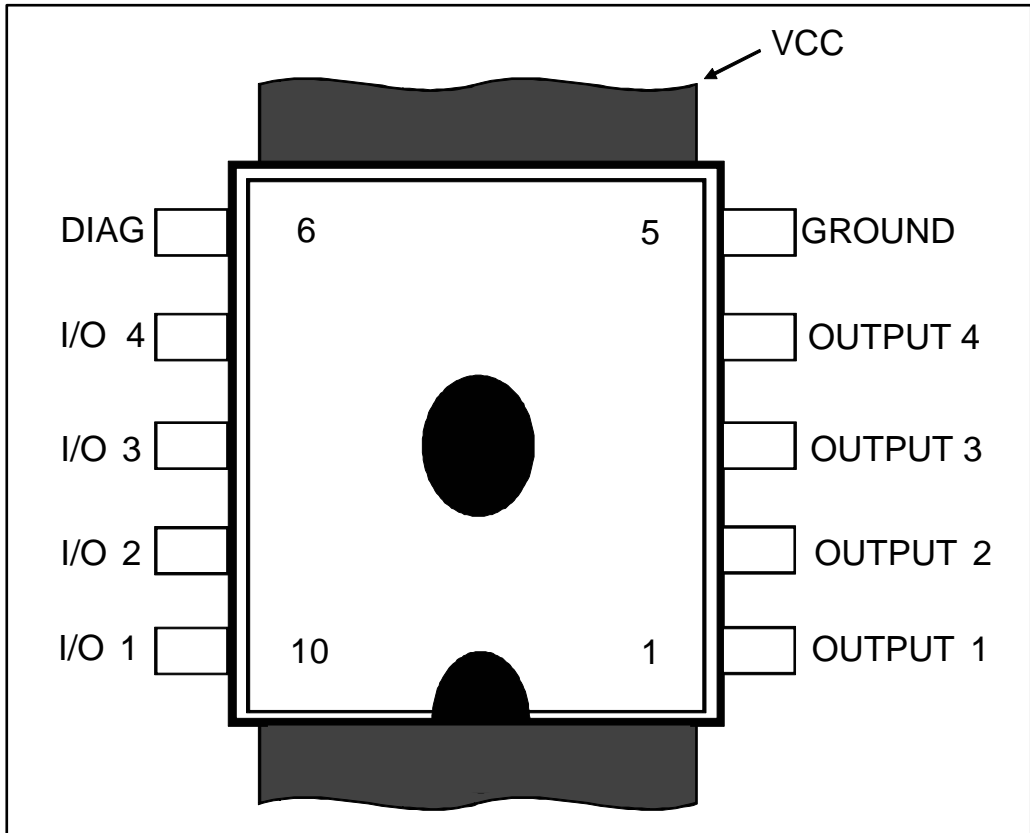
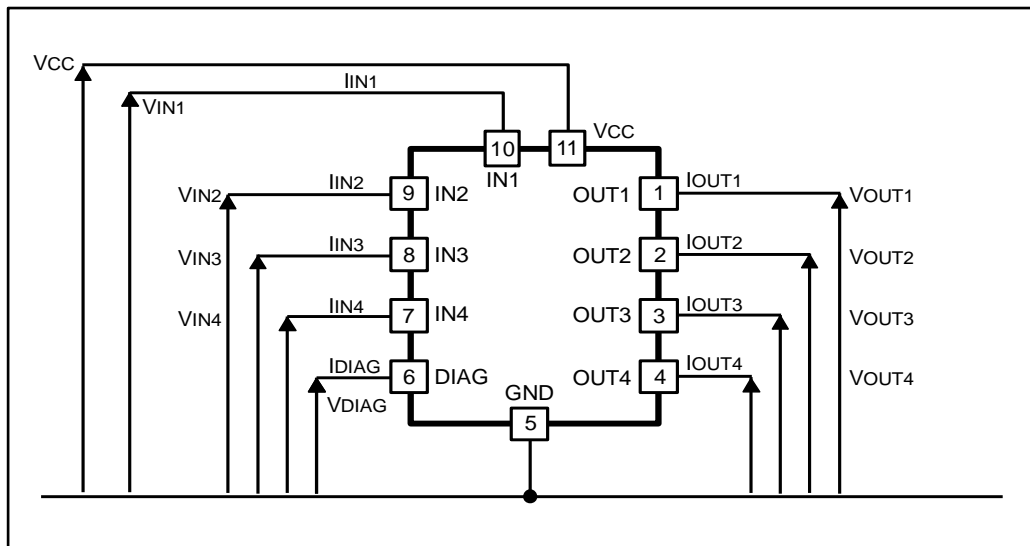

Figure 3: Current and voltage conventions



3 Maximum ratings

Table 2: Absolute maximum ratings

Symbol	Parameter	Value	Unit
V_{CC}	Power supply voltage	45	V
$-V_{CC}$	Reverse supply voltage	-4	V
I_{OUT}	Output current	Internally limited	A
I_R	Reverse output current (per channel)	-6	A
I_{IN}	Input current range	-1 to +10	mA
I_{DIAG}	Diag pin current	-1 to +10	mA
V_{ESD}	Electrostatic discharge (R = 1.5 k Ω ; C = 100 pF)	2000	V
E_{AS}	Single pulse avalanche energy one channel active $T_J = 125^\circ$, $I_{LOAD} = 0.625$ A	10	J
	Single pulse avalanche energy all channel active simultaneously $T_J = 125^\circ$, $I_{LOAD} = 0.625$ A	2	J
P_{TOT}	Power dissipation at $T_C = 25^\circ\text{C}$	Internally limited	W
T_J	Junction operating temperature	Internally limited	$^\circ\text{C}$
T_{STG}	Storage temperature	-55 to 150	$^\circ\text{C}$

Table 3: Thermal data

Symbol	Parameter	Value	Unit
$R_{th(JC)}$	Thermal resistance junction-case ⁽¹⁾	Max. 3	$^\circ\text{C/W}$
$R_{th(JA)}$	Thermal resistance junction-ambient ⁽²⁾	Max. 50	$^\circ\text{C/W}$

Notes:

⁽¹⁾Per channel.

⁽²⁾When mounted on a four-layer FR4, with the minimum recommended pad size.

4 Electrical characteristics

10 V < V_{CC} < 36 V; -40 °C < T_J < 125 °C; unless otherwise specified

Table 4: Power section

Symbol	Parameter	Test conditions	Min.	Typ.	Max.	Unit
V _{CC}	Supply voltage		10		36	V
R _{DS(on)}	On-state resistance	I _{OUT} = 0.5 A at T _J = 25 °C			0.2	Ω
		I _{OUT} = 0.5 A at T _J = 85 °C			0.32	
		I _{OUT} = 0.5 A at T _J = 125 °C			0.4	
I _S	Supply current	All channels in OFF-state, V _{IN} = 30 V, I _{OUT} = 0 V, T _J = 125 °C			1	mA
					6	mA
V _{OL}	Low state output voltage	V _{IN} = V _{IL} ; R _{LOAD} > = 10 MΩ			1.5	μA
I _{LGND}	Output current at turn-off	V _{CC} = V _{IN} = V _{GND} = V _{STAT} = 18 to 30 V T _A = -25 °C to 85 °C			2	mA
V _{demag}	Output current at turn-off	I _{OUT} = 0.5 A; L _{LOAD} > = 1 mH	V _{CC} -65	V _{CC} -55	V _{CC} -45	V

Table 5: Switching (V_{CC} = 24 V, T_J = 25 °C)

Symbol	Parameter	Test conditions	Min.	Typ.	Max.	Unit
t _{d(ON)}	Turn-on delay time	I _{OUT} = 0.5 A, resistive load, input rise time < 0.1 μs		52	100	μs
t _r	Rise time of output current	I _{OUT} = 0.5 A, resistive load, input rise time < 0.1 μs		94	250	μs
t _{d(OFF)}	Turn-off delay time of output current	I _{OUT} = 0.5 A, resistive load, input rise time < 0.1 μs		34	50	μs
t _f	Fall time	I _{OUT} = 0.5 A, resistive load, input rise time < 0.1 μs		8	20	μs

Table 6: Logic inputs

Symbol	Parameter	Test conditions	Min.	Typ.	Max.	Unit
V_{IL}	I/O input low level voltage				2	V
V_{IH}	I/O input high level voltage		3.5			V
$V_{I(HYST)}$	I/O input hysteresis voltage			0.5		V
I_{IN}	I/O input current	$V_{IN} = 30\text{ V}$			25	μA
V_{ICL}	I/O input clamp voltage ⁽¹⁾	$I_{IN} = 1\text{ mA}$	32	36		V
		$I_{IN} = -1\text{ mA}$		-0.7		V

Notes:

⁽¹⁾The input voltage is internally clamped at 32 V minimum, the input pins can be connected to a higher voltage by an external resistor, which cannot exceed 10 mA

Table 7: Protection and diagnostic

Symbol	Parameter	Test conditions	Min.	Typ.	Max.	Unit
$V_{DIAG}^{(1)}$	Status voltage output low	$I_{DIAG} = 5\text{ mA}$ (fault condition)			1	V
V_{SCL}	Status clamp voltage	$I_{DIAG} = 1\text{ mA}$	32	36 -0.7		
V_{USD}	Undervoltage shutdown		5		8	V
I_{lim}	DC short-circuit current	$V_{CC} = 24\text{ V}; R_{LOAD} < 10\text{ m}\Omega$	1		2	A
I_{OVPK}	Peak short-circuit current	$V_{CC} = 24\text{ V}; V_{IN} = 30\text{ V}; R_{LOAD} < 10\text{ m}\Omega$			4	V
I_{DIAGH}	Leakage on DIAG pin in high state	$V_{DIAG} = 24\text{ V}$			25	μA
I_{LOAD}	Output leakage current	$V_{CC} = 10\text{ to }36\text{ V}; V_{IN} = V_{IL}$			50	μA
t_{SC}	Delay time of current limiter				100	μs
T_{TSD}	Junction shutdown temperature		150	170		$^{\circ}\text{C}$
T_R	Junction reset temperature		135	155		$^{\circ}\text{C}$

Notes:

⁽¹⁾Status determination > 100 μs after the switching edge.



If the INPUT pin is left floating, the corresponding channel automatically switches off. If GND pin is disconnected, the channel switches off provided that V_{CC} does not exceed 36 V.

5 Test circuits

Figure 4: Avalanche energy test circuit

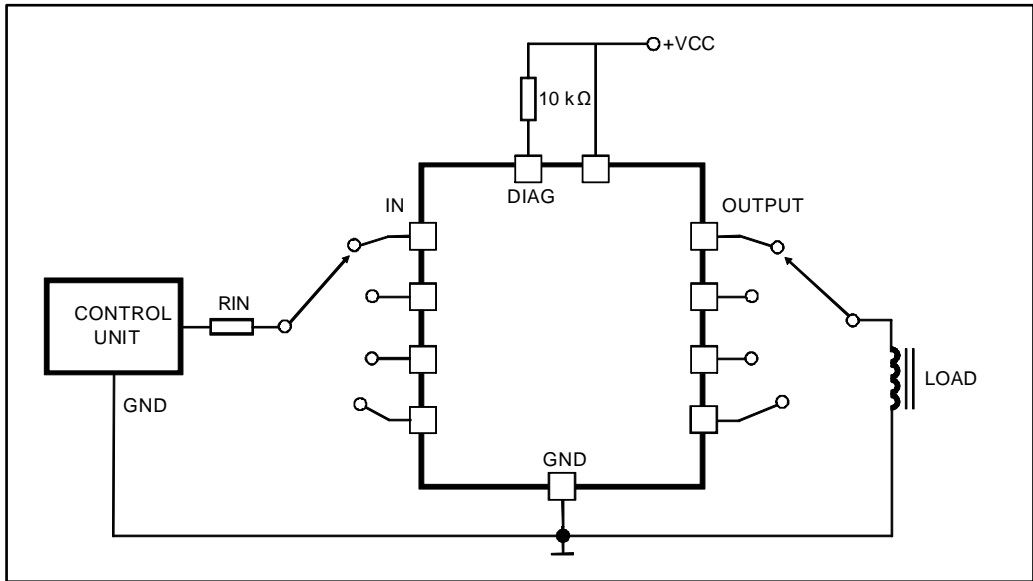

Figure 5: Peak short-circuit test diagram

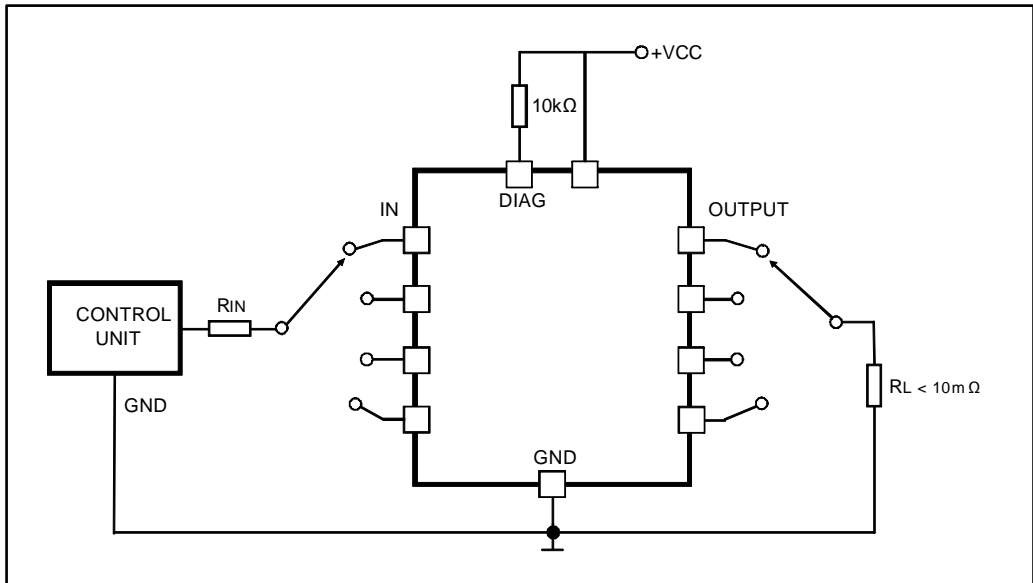
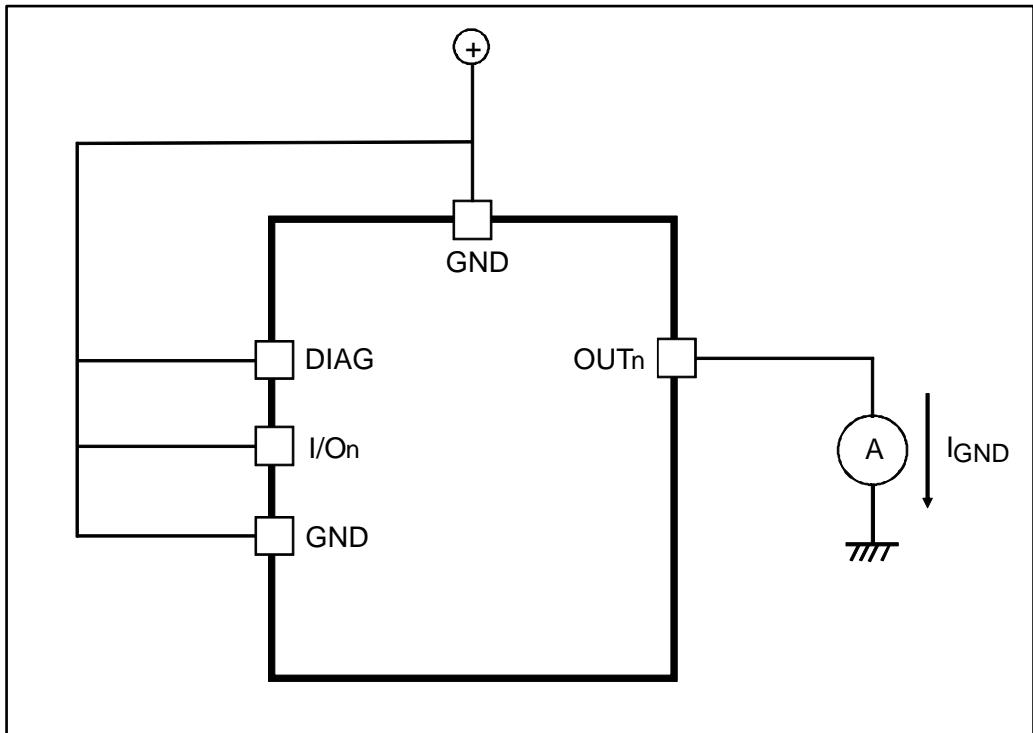

Figure 6: I_{LGND} test configuration



6 Switching time waveforms and truth table

Figure 7: Switching waveforms

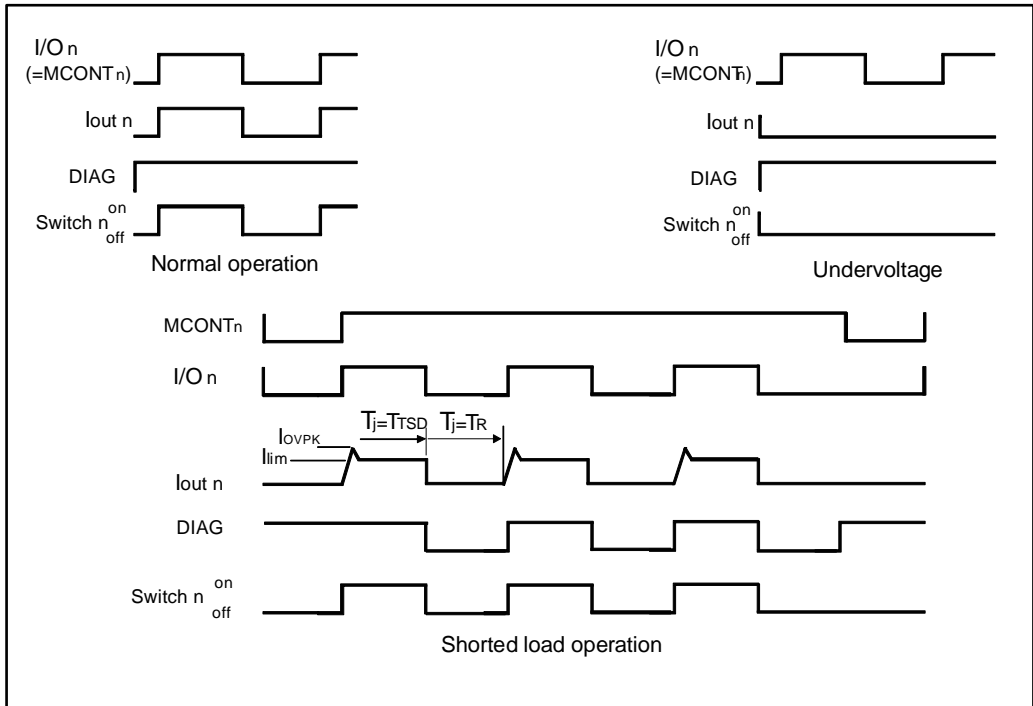

Figure 8: Switching parameter test conditions

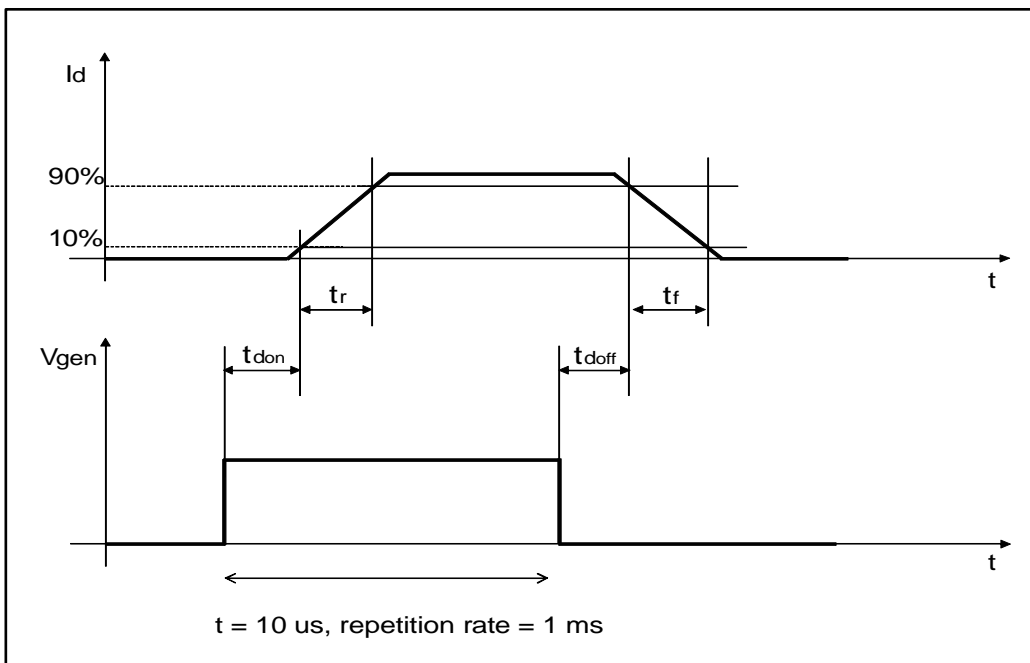
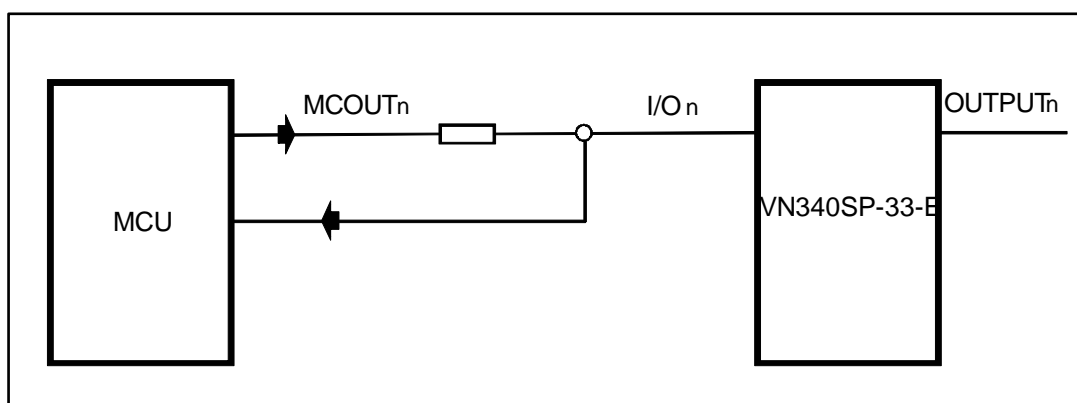

Table 8: Truth table

Conditions	MCOUTn	I/O n	OUTPUTn	Diagnostic
Normal operation	L	L	L	H
	H	H	H	H
Junction overtemperature	L	L	L	H
	H	L	L	L
Undervoltage	L	L	L	H
	H	H	L	H
Shorted load current limitation	L	L	L	H
	H	H	H	H

Figure 9: Driving circuit



7 Package information

In order to meet environmental requirements, ST offers these devices in different grades of ECOPACK® packages, depending on their level of environmental compliance. ECOPACK® specifications, grade definitions and product status are available at: www.st.com. ECOPACK® is an ST trademark.

7.1 PowerSO-10 package information

Figure 10: PowerSO-10 package outline

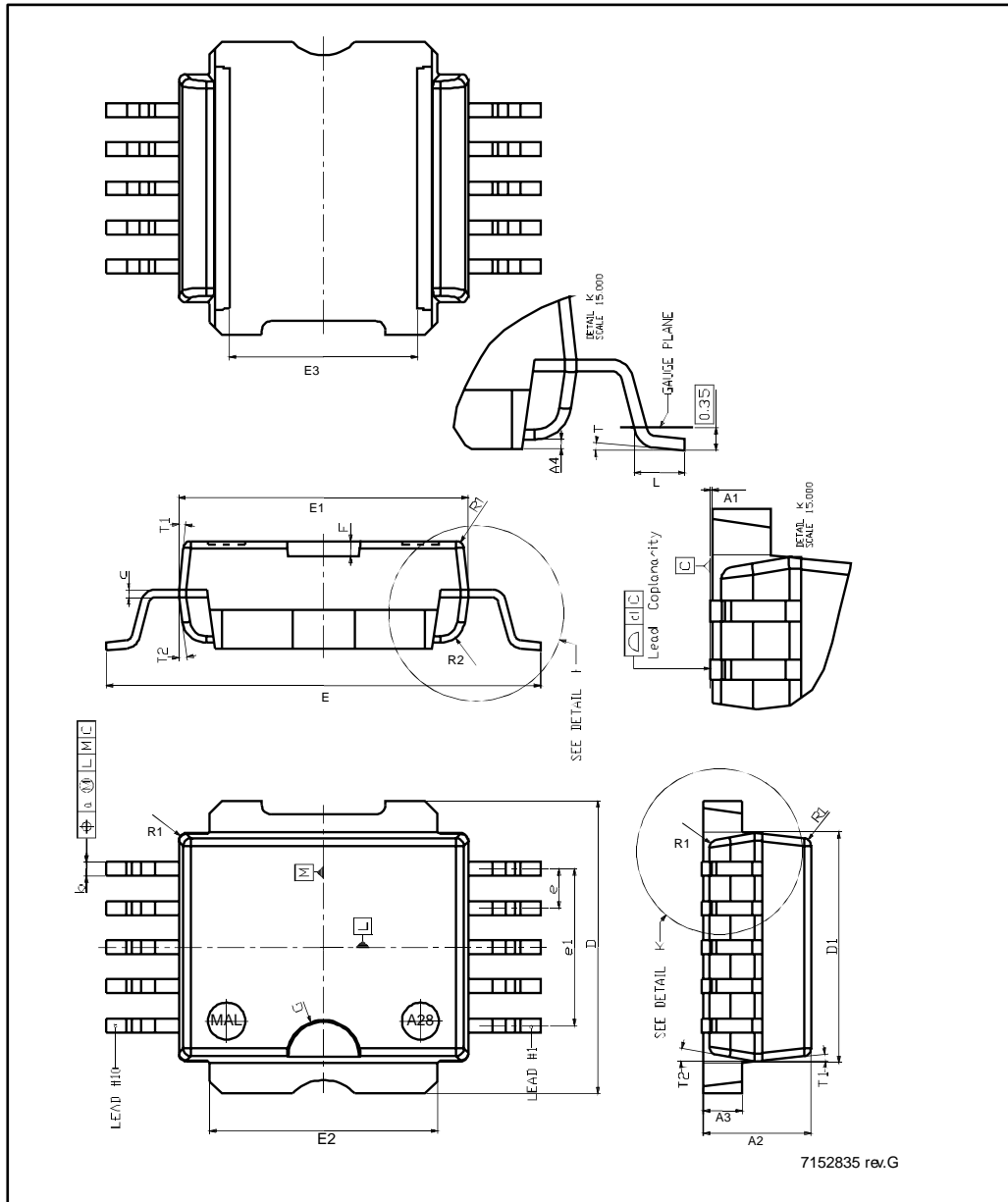

Table 9: PowerSO-10 package mechanical data

Dim.	mm		
	Min.	Typ.	Max.
A1	0.01	0.05	0.08
A2	3.45	3.5	3.55
A3	1.24	1.28	1.32
A4	0.15	0.2	0.25
a		0.2	
b	0.4	0.45	0.5
c	0.24	0.27	0.3
D	9.45	9.52	9.59
D1	7.42	7.5	7.58
d	0	0.04	0.09
E	13.9	14.1	14.3
E1 ^a	9.33	9.4	9.47
E2	7.4	7.42	7.5
E3	5.95	6.1	6.25
e	1.22	1.27	1.32
e1		5.08	
F		0.5	
G		1.2	
L	0.85	1	1.1
R1			0.25
R2		0.8	
T	3 deg	5 deg	7 deg
T1		6 deg	
T2		10deg	

^a Resin protrusions are not included (max. value: 0.15 mm per side).

7.2 PowerSO-10 packing information

Figure 11: PowerSO-10 career tape outline

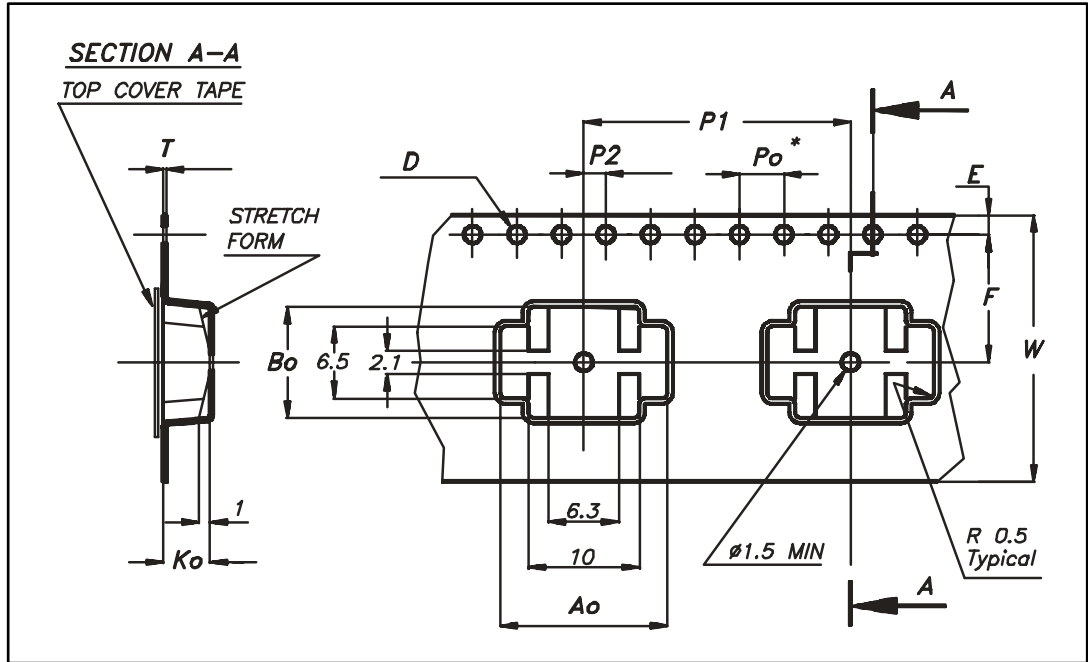

Drawing is not in scale

Table 10: PowerSO-10 career tape dimension mechanical data

Dim.	mm		
	Min.	Typ.	Max.
A0	14.9	15.0	15.1
B0	9.9	10.0	10.1
K0	4.15	4.25	4.35
F	11.4	11.5	11.6
E	1.65	1.75	1.85
W	23.7	24.0	24.3
P2	1.9	2.0	2.1
P0	3.9	4.0	4.1
P1	23.9	24.0	24.1
T	0.025	0.30	0.35
D(Ø)	1.50	1.55	1.60



10 sprocket hole pitch cumulative tolerance ± 0.2 mm

Figure 12: PowerSO-10 reel outline

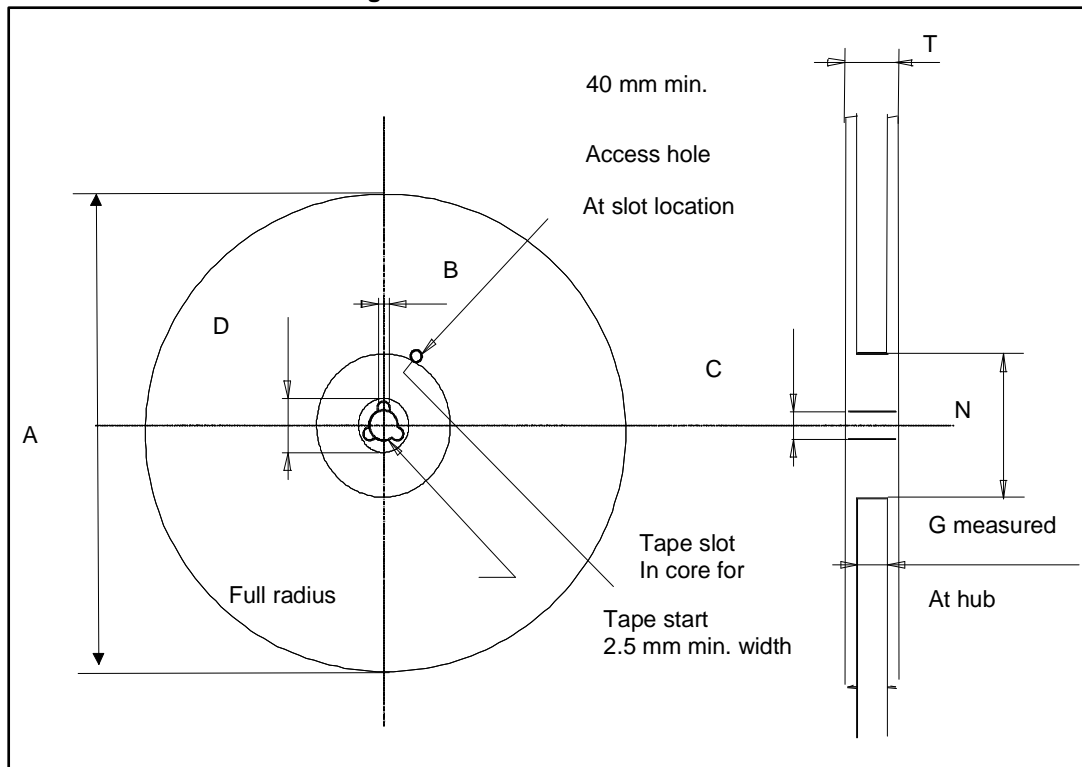

Drawing is not in scale

Table 11: PowerSO-10 reel dimension mechanical data

Dim.	mm		
	Min.	Typ.	Max.
A			330
B	1.5		
C	12.8	13	13.2
D	20.2		
N	60		
G	23.7	24.4	
T			30.4



10 sprocket hole pitch cumulative tolerance ± 0.2 mm

Table 12: PowerSO-10 base and bulk quantity

Base quantity	Bulk quantity
600	600

8 Revision history

Table 13: Document revision history

Date	Revision	Changes
05-Sep-2005	1	Initial release.
19-Mar-2007	2	Document reformatted, typo in note 1.
22-Aug-2008	3	Updated table 9.
07-Sep-2015	4	Updated the table of absolute maximum ratings.

IMPORTANT NOTICE – PLEASE READ CAREFULLY

STMicroelectronics NV and its subsidiaries ("ST") reserve the right to make changes, corrections, enhancements, modifications, and improvements to ST products and/or to this document at any time without notice. Purchasers should obtain the latest relevant information on ST products before placing orders. ST products are sold pursuant to ST's terms and conditions of sale in place at the time of order acknowledgement.

Purchasers are solely responsible for the choice, selection, and use of ST products and ST assumes no liability for application assistance or the design of Purchasers' products.

No license, express or implied, to any intellectual property right is granted by ST herein.

Resale of ST products with provisions different from the information set forth herein shall void any warranty granted by ST for such product.

ST and the ST logo are trademarks of ST. All other product or service names are the property of their respective owners.

Information in this document supersedes and replaces information previously supplied in any prior versions of this document.

© 2015 STMicroelectronics – All rights reserved

Данный компонент на территории Российской Федерации

Вы можете приобрести в компании MosChip.

Для оперативного оформления запроса Вам необходимо перейти по данной ссылке:

<http://moschip.ru/get-element>

Вы можете разместить у нас заказ для любого Вашего проекта, будь то серийное производство или разработка единичного прибора.

В нашем ассортименте представлены ведущие мировые производители активных и пассивных электронных компонентов.

Нашей специализацией является поставка электронной компонентной базы двойного назначения, продукции таких производителей как XILINX, Intel (ex.ALTERA), Vicor, Microchip, Texas Instruments, Analog Devices, Mini-Circuits, Amphenol, Glenair.

Сотрудничество с глобальными дистрибьюторами электронных компонентов, предоставляет возможность заказывать и получать с международных складов практически любой перечень компонентов в оптимальные для Вас сроки.

На всех этапах разработки и производства наши партнеры могут получить квалифицированную поддержку опытных инженеров.

Система менеджмента качества компании отвечает требованиям в соответствии с ГОСТ Р ИСО 9001, ГОСТ РВ 0015-002 и ЭС РД 009

Офис по работе с юридическими лицами:

105318, г.Москва, ул.Щербаковская д.3, офис 1107, 1118, ДЦ «Щербаковский»

Телефон: +7 495 668-12-70 (многоканальный)

Факс: +7 495 668-12-70 (доб.304)

E-mail: info@moschip.ru

Skype отдела продаж:

moschip.ru

moschip.ru_4

moschip.ru_6

moschip.ru_9