



SFP10G-ZR80 / SFP10G-ZR80-I

10Gbps SFP optical Transceiver,
Single-mode / 80KM, 1550nm

Highlights

- Compliant with IEEE802.3ae 10GBase-ZR Ethernet Standard
- Compliant with SFF8472 diagnostic monitoring interface
- Compliant with SFP+ MSA
- 1550nm EML laser transmitter
- 2-wire interface for management and diagnostic monitor
- Low power consumption, less than 1.8W
- Single power supply 3.3VDC



Features

- RoHS compliant
- Compliant with IEEE802.3ae 10GBase-ZR Ethernet Standard
- Industry standard small form pluggable (SFP) package
- Duplex LC connector
- 1550nm EML laser transmitter
- Single power detect indicator
- 2-wire interface for management and diagnostic monitor
- Hot Pluggable
- Transmission distance of 80Km over single-mode fiber
- Low power consumption, less than 1.8W

Application

- Distributed multi-processing
- Switch to switch interface
- High speed I/O for file server
- Bus extension application
- Channel extender, data storage

Pin-Assignment

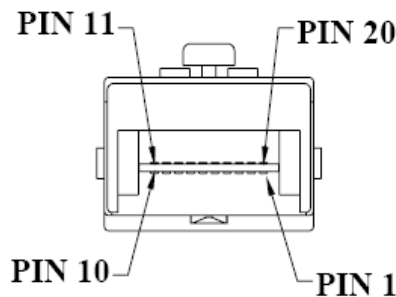

Pin	Signal Name	Description
1	T _{GND}	Transmit Ground
2	TX_FAULT	Transmit Fault
3	TX_DISABLE	Transmit disable
4	MOD_DEF (2)	SDA Serial Data Signal
5	MOD_DEF (1)	SCL Serial Clock Signal
6	MOD_DEF (0)	TTL Low
7	RATE SELECT	Open Circuit
8	RX_LOS	Receiver Loss of Signal, TTL High, open collector
9	R _{GND}	Receiver Ground
10	R _{GND}	Receiver Ground
11	R _{GND}	Receiver Ground
12	RX-	Receiver Data Bar, Differential PECL, ac coupled
13	RX+	Receiver Data, Differential PECL, ac coupled
14	R _{GND}	Receiver Ground
15	V _{CCR}	Receiver Power Supply
16	V _{CCT}	Transmitter Power Supply
17	T _{GND}	Transmit Ground
18	TX+	Transmit Data, Differential PECL, ac coupled
19	TX-	Transmit Data Bar, Differential PECL, ac coupled
20	T _{GND}	Transmit Ground

Dimension

Unit = mm

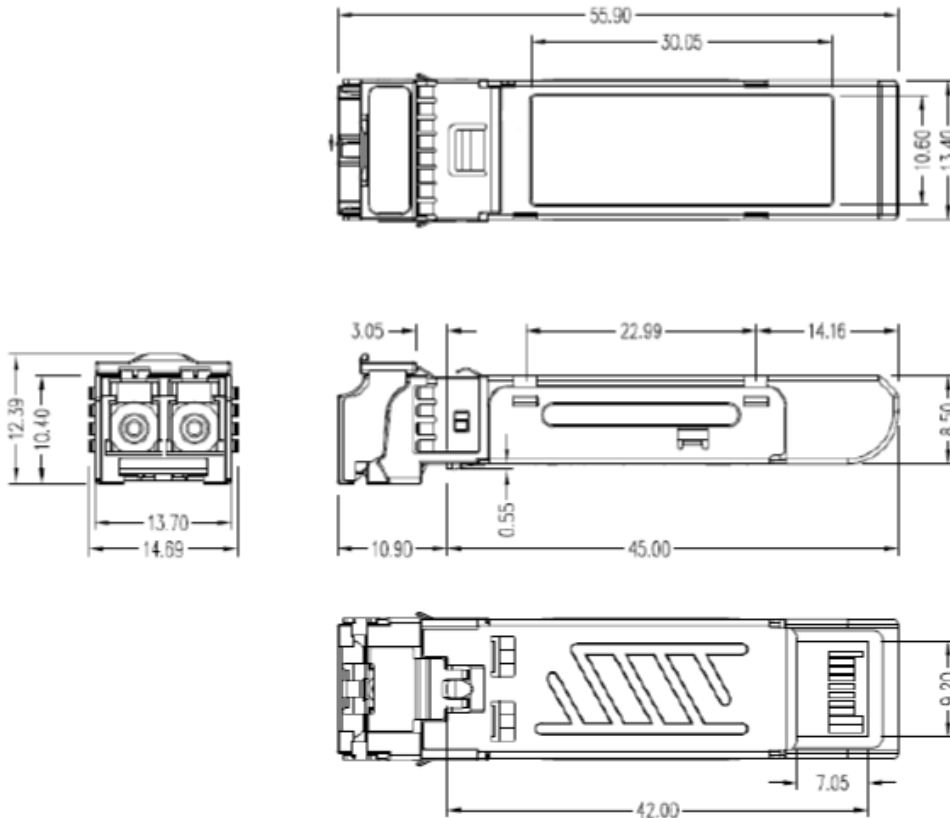

Specifications

ABSOLUTE MAXIMUM RATINGS :						
Parameter	Symbol	Min	Max	Units		
Storage Temperature	Ts	-40	85	°C		
Supply Voltage	Vcc	-0.5	4.0	V		
Input Voltage	VIN	-0.5	Vcc	V		
Output Current	Io	-	50	mA		
RECOMMENDED OPERATING CONDITIONS :						
Parameter	Symbol	Min	Max	Units		
Case Operating Temperature	Tc	SFP10G-ZR80 = 0 SFP10G-ZR80-I = -40	SFP10G-ZR80 = 70 SFP10G-ZR80-I = 85	°C		
Supply Voltage	Vcc	3.1	3.5	V		
Supply Current	ITX + IRX	400	520	mA		
TRANSMITTER ELECTRO-OPTICAL CHARACTERISTICS : Vcc = 3.1V to 3.5V, Tc=0°C to 70°C (-40°C to 85°C)						
Parameter	Symbol	Min	Typ.	Max	Units	Note
Data Rate	B	9.953	10.3125	11.3	Gb/s	
Output Optical Power 9/125 μ m fiber	POUT	0	-	+4	dBm	Average
Output Optical Power OMA	PO_OMA	-2.1	-	-	dBm	Average
Extinction Ratio	ER	3	-	-	dB	
Center Wavelength	λ_c	1530	1550	1565	nm	
Spectral Width (-20dB)	$\Delta\lambda$	-	-	1	nm	
Rise / Fall Time, (10-90%)	Tr, f	-	-	3	ns	
Differential Input Voltage	VDIFF	0.18	-	0.7	V	
RECEIVER ELECTRO-OPTICAL CHARACTERISTICS : Vcc = 3.1V to 3.5V, Tc=0°C to 70°C (-40°C to 85°C)						
Parameter	Symbol	Min	Typ.	Max	Units	Note
Data Rate	B	9.953	10.3125	11.3	Gb/s	
Optical Input Power-maximum	PIN_max	-	-	-7	dBm	
Optical Input Power-minimum (Sensitivity)	PIN_min	-	-	-23	dBm	
Operating Center Wavelength	λ_c	1250	1550	1600	nm	
Data Output Rise, Fall Time (10-90%)	Tr, f	-	-	30	ps	
Loss of Signal-Asserted	PA	-40	-	-	dBm	Average
Loss of Signal-Deasserted	PD	-	-	-24	dBm	Average
Loss of Signal-Hysteresis	PA - PD	0.5	-	-	dB	
Differential Output Voltage	VDIFF	0.3	-	0.85	V	
Receiver Loss of Signal Output Voltage-Low	RX_LOSL	0	-	0.5	V	
Receiver Loss of Signal Output Voltage-High	RX_LOSH	2.4	-	Vcc	V	

Ordering Information

SFP10G-ZR80-A

Code Definition	Transceiver Distance	Additional Port Type
Option	- 80: 80 KM	-I: Industrial extended model for -40 ~ 85°C * Regular model : 0 ~ 70°C

Available Model	Model Name	Description	Operating Temperature
	SFP10G-ZR80	10Gbps SFP optical Transceiver, Single-mode / 80KM, 1550nm,	0 ~ 70°C
	SFP10G-ZR80-I	10Gbps SFP optical Transceiver, Single-mode / 80KM, 1550nm,	-40 ~ 85°C

Данный компонент на территории Российской Федерации

Вы можете приобрести в компании MosChip.

Для оперативного оформления запроса Вам необходимо перейти по данной ссылке:

<http://moschip.ru/get-element>

Вы можете разместить у нас заказ для любого Вашего проекта, будь то серийное производство или разработка единичного прибора.

В нашем ассортименте представлены ведущие мировые производители активных и пассивных электронных компонентов.

Нашей специализацией является поставка электронной компонентной базы двойного назначения, продукции таких производителей как XILINX, Intel (ex.ALTERA), Vicor, Microchip, Texas Instruments, Analog Devices, Mini-Circuits, Amphenol, Glenair.

Сотрудничество с глобальными дистрибьюторами электронных компонентов, предоставляет возможность заказывать и получать с международных складов практически любой перечень компонентов в оптимальные для Вас сроки.

На всех этапах разработки и производства наши партнеры могут получить квалифицированную поддержку опытных инженеров.

Система менеджмента качества компании отвечает требованиям в соответствии с ГОСТ Р ИСО 9001, ГОСТ РВ 0015-002 и ЭС РД 009

Офис по работе с юридическими лицами:

105318, г.Москва, ул.Щербаковская д.3, офис 1107, 1118, ДЦ «Щербаковский»

Телефон: +7 495 668-12-70 (многоканальный)

Факс: +7 495 668-12-70 (доб.304)

E-mail: info@moschip.ru

Skype отдела продаж:

moschip.ru

moschip.ru_4

moschip.ru_6

moschip.ru_9