

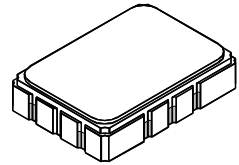

SF2038B-3

**76.500 MHz
SAW Filter**



SMP-03-S

- **Designed for SDARS IF Receiver**
- **Low Insertion Loss**
- **5.0 X 7.0 mm Surface-Mount Case**
- **Differential or Single Ended Input and Output**
- **Complies with Directive 2002/95/EC (RoHS)**



Absolute Maximum Ratings

Rating	Value	Units
Maximum Incident Power in Passband	+10	dBm
Max. DC voltage between any 2 terminals	30	VDC
Storage Temperature Range	-40 to +85	°C
Max Soldering Profile	265°C for 10 s	

Electrical Characteristics

Characteristic	Sym	Notes	Min	Typ	Max	Units
Nominal Center Frequency	f_c		76.500			MHz
Passband	Insertion Loss	IL		10.0	12.0	dB
			1dB Passband	BW ₁	12.5	14.0
	15dB Bandwidth	BW ₁₅		16.8	18.0	MHz
	30dB Bandwidth	BW ₃₀		18.0	19.2	MHz
	Amplitude Ripple over $f_c \pm 6.25$ MHz			0.70	1.3	dB _{P-P}
	Group Delay Variation over $f_c \pm 6.25$ MHz	GDV		40	150	ns _{P-P}
Rejection	50 to 64.44 MHz	1, 3	40	46		dB
	64.44 to 66.70 MHz		36	41		
	86.30 to 87.54 MHz		30	44		
	87.54 to 91.50 MHz		31	44		
	91.50 to 100 MHz		40	47		
Operating Temperature Range	T _A	1	-40		+85	°C
Frequency Coefficient	FTC			-87		ppm/°C
Differential Input	175 ohms					
Differential Output	180 ohms					
Case Style	SMP-03-S 7 x 5 mm Nominal Footprint					
Lid Symbolization (YY=year, WW=week, S=shift) See note 4	RFM SF2038B-3 YYWWS					

Electrical Connections

Connection	Port 1 Hot	Port 1 Ground Return or Hot	Port 2 Hot	Port 2 Ground Return or Hot	Case Ground
Terminals	10	1	5	6	All Others

Notes:

1. Unless noted otherwise, all specifications apply over the operating temperature range with filter soldered to the specified demonstration board with impedance matching to 50 Ω and measured with 50 Ω network analyzer.
2. Unless noted otherwise, all frequency specifications are referenced to the nominal center frequency, f_c .
3. Rejection is measured as attenuation below the minimum IL point in the passband. Rejection in final user application is dependent on PCB layout and external impedance matching design. See Application Note No. 42 for details.
4. "LRIP" or "L" after the part number indicates "low rate initial production" and "ENG" or "E" indicates "engineering prototypes."
5. The design, manufacturing process, and specifications of this filter are subject to change.
6. Tape and Reel Standard ANSI / EIA 481.
7. Either Port 1 or Port 2 may be used for either input or output in the design. However, impedances and impedance matching may vary between Port 1 and Port 2, so that the filter must always be installed in one direction per the circuit design.
8. US and international patents may apply.
9. RFM, stylized RFM logo, and RF Monolithics, Inc. are registered trademarks of RF Monolithics, Inc.
10. ©Copyright 1999, RF Monolithics Inc.
11. Electrostatic Sensitive Device. Observe precautions for handling.



SMP-03-S Case 

12-Terminal Ceramic Surface-Mount Case
5 x 7 mm Nominal Footprint

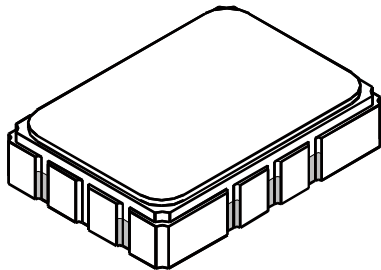

Case Dimensions						
Dimension	mm			Inches		
	Min	Nom	Max	Min	Nom	Max
A	6.80	7.00	7.20	0.268	0.276	0.283
B	4.80	5.00	5.20	0.189	0.197	0.205
C		1.65	2.00		0.065	0.079
D		0.80				
E	2.41	2.54	2.67	0.095	0.100	0.105
H	0.87	1.1	1.13	0.034	0.039	0.044
J		2.54				
K	2.87	3.00	3.13	0.113	0.118	0.123
P	1.14	1.27	1.40	0.045	0.050	0.055

Materials	
Solder Pad Termination	Au plating 30 - 60 μinches (76.2-152 μm) over 80-200 μinches (203-508 μm) Ni.
Lid	Fe-Ni-Co Alloy Electroless Nickel Plate (8-11% Phosphorus) 100-200 μinches Thick
Body	Al ₂ O ₃ Ceramic
Pb Free	

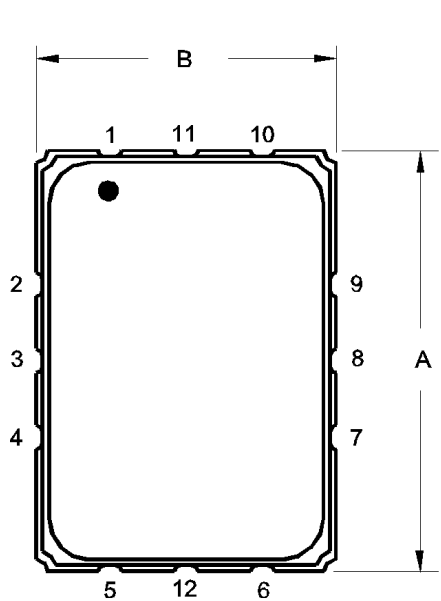

TOP VIEW

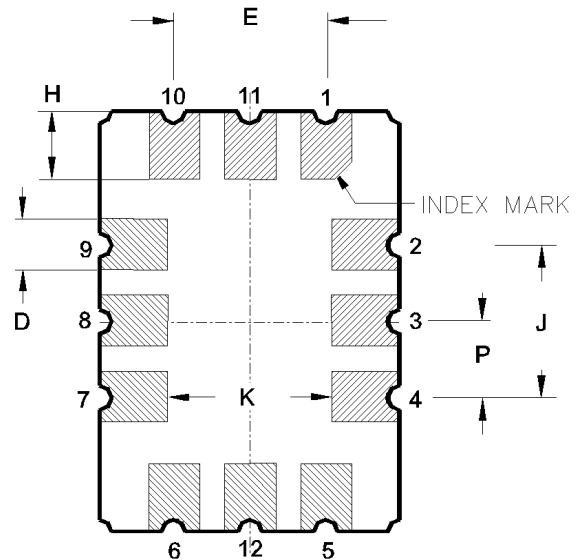
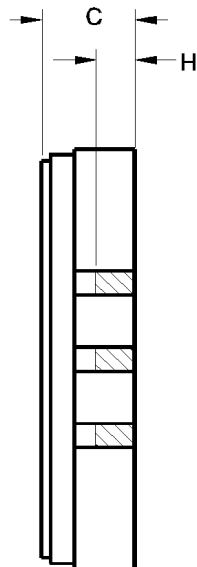

BOTTOM VIEW

COMPONENT ORIENTATION and DIMENSIONS

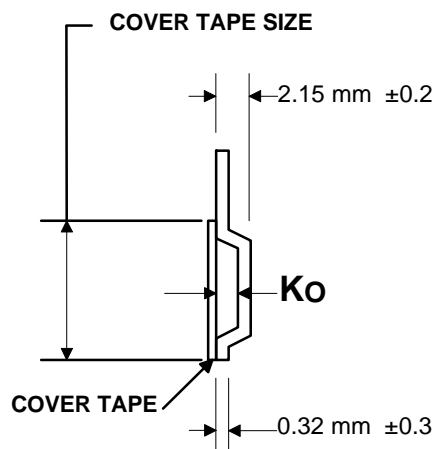
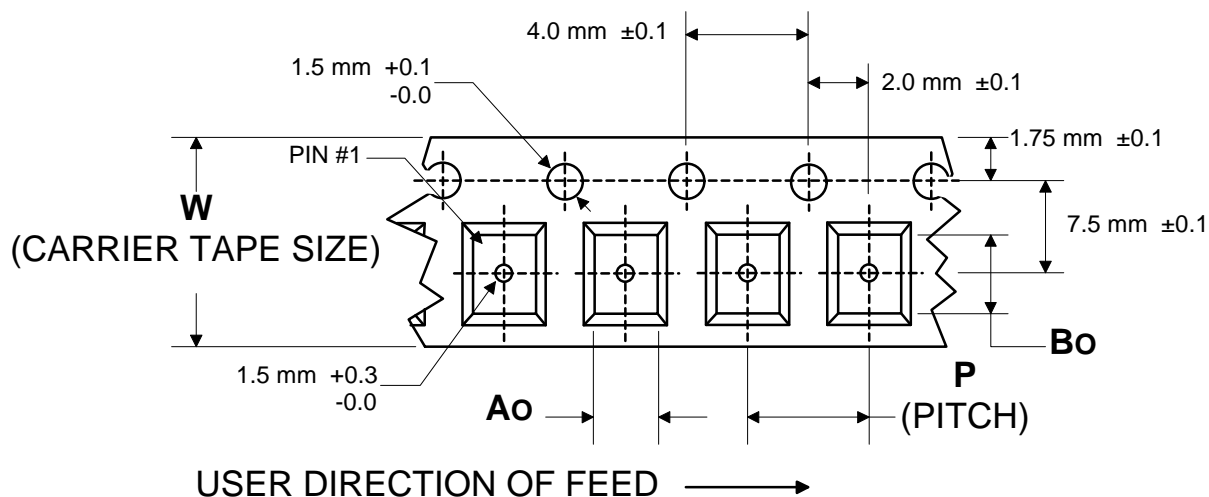

Carrier Tape Dimensions		
Ao	5.5 mm	± 0.1
Bo	7.5 mm	± 0.1
Ko	2.0 mm	± 0.1
Pitch	8.0 mm	± 0.1
W	16.0 mm	± 0.3

Данный компонент на территории Российской Федерации

Вы можете приобрести в компании MosChip.

Для оперативного оформления запроса Вам необходимо перейти по данной ссылке:

<http://moschip.ru/get-element>

Вы можете разместить у нас заказ для любого Вашего проекта, будь то серийное производство или разработка единичного прибора.

В нашем ассортименте представлены ведущие мировые производители активных и пассивных электронных компонентов.

Нашей специализацией является поставка электронной компонентной базы двойного назначения, продукции таких производителей как XILINX, Intel (ex.ALTERA), Vicor, Microchip, Texas Instruments, Analog Devices, Mini-Circuits, Amphenol, Glenair.

Сотрудничество с глобальными дистрибьюторами электронных компонентов, предоставляет возможность заказывать и получать с международных складов практически любой перечень компонентов в оптимальные для Вас сроки.

На всех этапах разработки и производства наши партнеры могут получить квалифицированную поддержку опытных инженеров.

Система менеджмента качества компании отвечает требованиям в соответствии с ГОСТ Р ИСО 9001, ГОСТ РВ 0015-002 и ЭС РД 009

Офис по работе с юридическими лицами:

105318, г.Москва, ул.Щербаковская д.3, офис 1107, 1118, ДЦ «Щербаковский»

Телефон: +7 495 668-12-70 (многоканальный)

Факс: +7 495 668-12-70 (доб.304)

E-mail: info@moschip.ru

Skype отдела продаж:

moschip.ru

moschip.ru_4

moschip.ru_6

moschip.ru_9