

# Rotary Position Sensors



### **EU RoHS Compliant**

- All the products in this catalog comply with EU RoHS.
- EU RoHS is "the European Directive 2011/65/EU on the Restriction of the Use of Certain Hazardous Substances in Electrical and Electronic Equipment."
- For more details, please refer to our website 'Murata's Approach for EU RoHS' (<http://www.murata.com/info/rohs.html>).

# CONTENTS

|   |    |
|---|----|
| <b>Part Numbering</b>   | 2  |
| <b>1 SMD/Lead Dust-proof Type 12mm Size SV03 Series</b>             | 3  |
| ● SV03 Series Specifications and Test Methods                       | 5  |
| <b>2 SMD/Lead Dust-proof Type 12mm Size SV01 Series</b>             | 6  |
| ● SV01 Series Specifications and Test Methods                       | 8  |
| <b>SV Series Notice</b>   | 9  |
| <b>SV Series Packaging</b>  | 11 |
| <b>SV Series Application Manual</b>                                 | 12 |
| 1. Storage  | 12 |
| 2. Board Design   | 12 |
| 3. Circuit Design   | 14 |
| 4. Mechanical Design  | 15 |
| 5. System Design  | 15 |
| 6. Mounting the Product on a Printed Circuit Board and Soldering It | 15 |
| 7. Connecting the Product to a Mechanical Part                      | 17 |
| 8. Examples of Actual Trouble and Preventive Measures               | 18 |
| <b>Qualified Standards</b>  | 20 |

● Part Numbering

Rotary Position Sensor

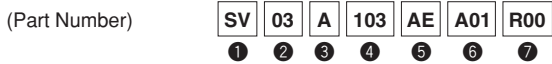

① Product ID

| Product ID |                        |
|------------|------------------------|
| SV         | Rotary Position Sensor |

② Series

| Code | Series                        |
|------|-------------------------------|
| 01   | Carbon Rotary Position Sensor |
| 03   | Carbon Rotary Position Sensor |

③ Terminal Shape

| Code | Terminal Shape |
|------|----------------|
| A    | SMD Type       |
| L    | Lead Type      |

④ Total Resistance

Expressed by three figures. The unit is ohm. The first and second figures are significant digits, and the third figure expresses the number of zeros which follow the two figures.

Ex.)

| Code | Total Resistance |
|------|------------------|
| 103  | 10000Ω (=10kΩ)   |

⑤ Rotor Hole Shape/Rotor Hole Size

| Code | Rotor Hole Shape/Rotor Hole Size |
|------|----------------------------------|
| AE   | D Hole/4.0mm Dia.                |

⑥ Individual Specification Code

| Series | Code | Individual Specification Code |
|--------|------|-------------------------------|
| SV01   | A01  | SMD Type Standard             |
|        | A11  | Lead Type Standard            |
| SV03   | A01  | SMD Type, Lead Type Standard  |

⑦ Packaging

| Code | Packaging |
|------|-----------|
| B00  | Bulk      |
| R00  | Reel      |
| T00  | Tray      |

# Rotary Position Sensors



1

## SMD/Lead Dust-proof Type 12mm Size SV03 Series

### ■ Features

1. High Durability: 1 Million cycles
2. Pb Free Soldering: 260 deg.C
3. Operating Temperature: -40 deg.C to +125 deg.C
4. Terminal Shape: SMD Type and Lead Type
5. Rotational Rotor: Through Hole Type
6. Thin Type: 2.1mm
7. RoHS Compliant

### ■ Applications

1. Switch for White goods
2. Digital Still Camera
3. Switch for automotive
4. Car audio
5. Multi function printer
6. Robot
7. Motor drive unit

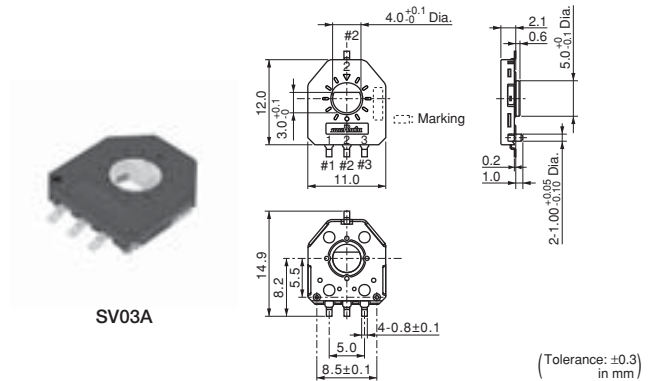

SV03A

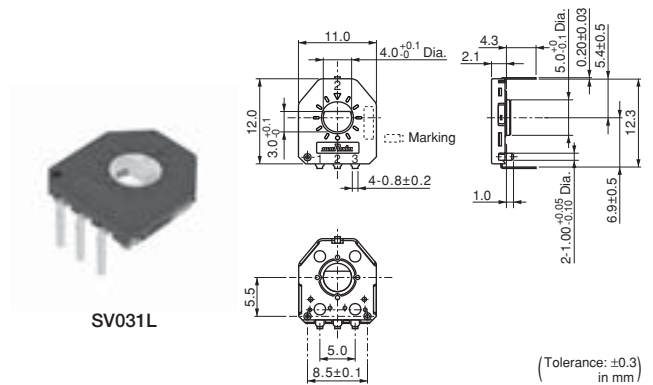

SV031L

| Part Number   | Total Resistance Value (k ohm) | Linearity (%) | Effective Rotational Angle | Rotational Torque         | Rotational Life |
|---------------|--------------------------------|---------------|----------------------------|---------------------------|-----------------|
| SV03A103AEA01 | 10 ±30%                        | ±2            | 333.3° (Ref.)              | 2mN.m (Ref.:21gf.cm) max. | 300k cycles     |
| SV03L103AEA01 | 10 ±30%                        | ±2            | 333.3° (Ref.)              | 2mN.m (Ref.:21gf.cm) max. | 300k cycles     |

### ■ Constructions

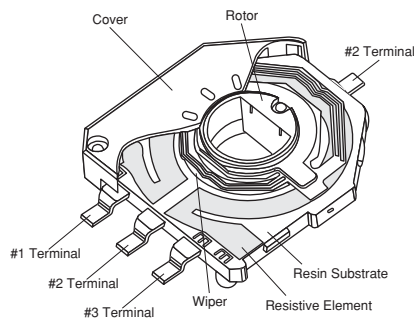

## Standard Land Pattern

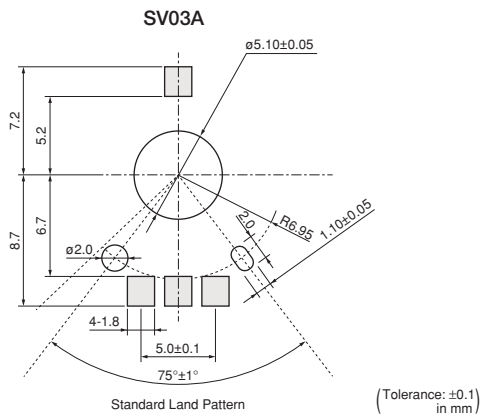

## Standard Mounting Holes

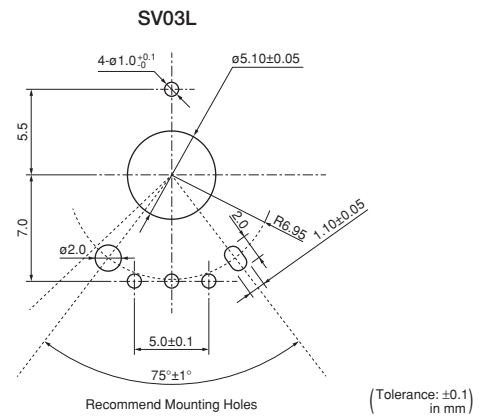

## Characteristics

|                                      |                                 |
|--------------------------------------|---------------------------------|
| Temperature Cycle<br>(Thermal Shock) | ΔTR : ±20%<br>Linearity: ±3%    |
| Humidity                             | ΔTR : ±20%<br>Linearity: ±3%    |
| Vibration                            | ΔTR : ±10%<br>Linearity: ±3%    |
| Shock                                | ΔTR : ±10%<br>Linearity: ±3%    |
| Humidity Load Life                   | ΔTR : ±20%<br>Linearity: ±3%    |
| High Temperature<br>Exposure         | ΔTR : +5/-30%<br>Linearity: ±3% |
| Low Temperature<br>Exposure          | ΔTR : ±20%<br>Linearity: ±3%    |
| Rotational Life                      | ΔTR : ±20%<br>Linearity: ±3%    |

ΔTR: Total Resistance Change

# SV03 Series Specifications and Test Methods

The tests and measurements should be conducted under the condition of 15 to 35°C of temperature 25 to 75% of relative humidity and 86 to 106 kpa of atmospheric pressure unless otherwise specified. If questionable results occur that have been measured in accordance with the above mentioned conditions, the tests and measurements should be conducted under the condition of 25±2°C of temperature, 45 to 55% of relative humidity and 86 to 106 kpa of atmospheric pressure. When the potentiometer is tested after soldering on PCB, it should be tested after being kept in a room (15 to 35°C, 25 to 75%RH) over 24 hours except "Resistance to soldering heat".

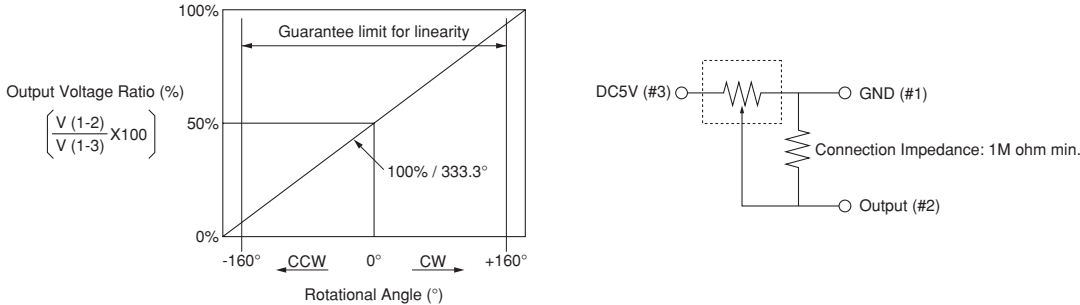
| No.              | Item                              | Test Methods  |          |            |   |   |   |                  |       |            |        |            |             |    |        |    |        |
|------------------|-----------------------------------|---|----------|------------|---|---|---|------------------|-------|------------|--------|------------|-------------|----|--------|----|--------|
| 1                | Linearity                         | <p>Linearity should be specified a deviation with the below ideal straight line, between ±160° from the index point which is 50% of out put voltage.<br/>                     The ideal straight line has 100%/333.3° as taper and pass the above index point.<br/>                     Measurement is performed using the following measurement circuit, and the rotor should be rotated to clockwise direction.</p>   |          |            |   |   |   |                  |       |            |        |            |             |    |        |    |        |
| 2                | Temperature Cycle (Thermal Shock) | <p>The rotary position sensor should be subjected to Table 2 temperature for 5 cycles.<br/>                     Then, the rotary position sensor should be kept in the dry box for 24 +8/-0 hrs.</p> <table border="1" data-bbox="367 918 1236 996"> <thead> <tr> <th>Sequence</th> <th>1</th> <th>2</th> <th>3</th> <th>4</th> </tr> </thead> <tbody> <tr> <td>Temperature (°C)</td> <td>-40±3</td> <td>Shift Time</td> <td>+125±3</td> <td>Shift Time</td> </tr> <tr> <td>Time (min.)</td> <td>30</td> <td>5 max.</td> <td>30</td> <td>5 max.</td> </tr> </tbody> </table> <p>Table 2: One cycle of temperature cycle</p> | Sequence | 1          | 2 | 3 | 4 | Temperature (°C) | -40±3 | Shift Time | +125±3 | Shift Time | Time (min.) | 30 | 5 max. | 30 | 5 max. |
| Sequence         | 1                                 | 2   | 3        | 4          |   |   |   |                  |       |            |        |            |             |    |        |    |        |
| Temperature (°C) | -40±3                             | Shift Time  | +125±3   | Shift Time |   |   |   |                  |       |            |        |            |             |    |        |    |        |
| Time (min.)      | 30                                | 5 max.  | 30       | 5 max.     |   |   |   |                  |       |            |        |            |             |    |        |    |        |
| 3                | Humidity                          | <p>The rotary position sensor should be stored in a chamber at temperature of +85±3°C and relative humidity of 85±5% for 1000±8 hrs. After removing from the chamber, the rotary position sensor should be kept in the dry box for 24 +8/-0 hours.</p>  |          |            |   |   |   |                  |       |            |        |            |             |    |        |    |        |
| 4                | Vibration                         | <p>The rotary position sensor should be log-swept by the sine oscillatory wave of the maximum amplitude 1.5mm, Acceleration 98m/s<sup>2</sup> (10G) under the condition of the vibrational frequency between 10Hz and 2kHz. In 1 cycle which is vibrated for each 20 minutes in the 3 direction of x, y, and z., 12 cycles should be applied during 12 hours in total.<br/>                     Then, the rotary position sensor should be kept in the dry box for 1 to 2 hours.</p>  |          |            |   |   |   |                  |       |            |        |            |             |    |        |    |        |
| 5                | Shock                             | <p>The rotary position sensor should be applied the following shock test: Half sine wave with the peak acceleration 14,700m/s<sup>2</sup> (1,500G) max. can be applied in each 3 times (total 18 times) in the 3 direction of x, y, and z with bidirectional.<br/>                     Then, the rotary position sensor should be kept in the dry box for 1 to 2 hours.</p>   |          |            |   |   |   |                  |       |            |        |            |             |    |        |    |        |
| 6                | Humidity Load Life                | <p>Full rated continuous working voltage not exceeding 5Vdc should be applied intermittently between terminal #1 and terminal #3 of the rotary position sensor, 1.5 hours on and 0.5 hours off, for 1000±8 hours in total in a chamber at a temperature of 85±3°C and relative humidity of 85±5%. After removing from the chamber, the rotary position sensor should be kept in the dry box for 5±1/6 hours.</p>  |          |            |   |   |   |                  |       |            |        |            |             |    |        |    |        |
| 7                | High Temp. Exposure               | <p>The rotary position sensor should be stored in a chamber at a temperature of 125±2°C without loading for 1000±8 hours. After removing from the chamber, the rotary position sensor should be kept in the dry box for 1 to 2 hours.</p>   |          |            |   |   |   |                  |       |            |        |            |             |    |        |    |        |
| 8                | Low Temp. Exposure                | <p>The rotary position sensor should be stored in a chamber at a temperature of -40±3°C without loading for 1000±8 hours. After removing from the chamber, the rotary position sensor should be kept in the dry box for 1 to 2 hours.</p>   |          |            |   |   |   |                  |       |            |        |            |             |    |        |    |        |
| 9                | Rotational Life                   | <p>The adjustment rotor should be continuously rotated within ±160° of effective electrical rotational angle, at the rate of 3 cycle for 1 second for 300 thousands cycles under the condition of 25±2°C of temperature without loading.<br/>                     Then, the rotary position sensor should be kept in the dry box for 10±5 minutes.</p>  |          |            |   |   |   |                  |       |            |        |            |             |    |        |    |        |

# Rotary Position Sensors



## SMD/Lead Dust-proof Type 12mm Size SV01 Series

2

### ■ Features

1. Excellent resistance materials and high reliability wiper achieves 1M cycles.
2. Leaded terminal type is available.
3. D formation thru-hole rotor enables selection of any kind of gear shape.
4. Ultra-thin size (2.1mm height)
5. Au plated terminals.
6. RoSH Compliant

### ■ Applications

1. Switch for White goods
2. Digital Still Camera
3. Switch for automotive
4. Car audio
5. Multi function printer
6. Robot
7. Motor drive unit

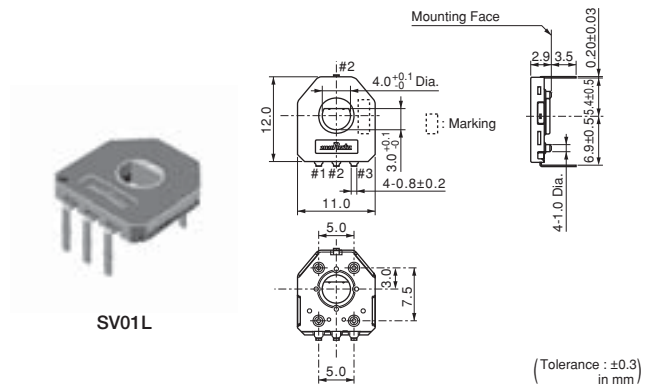
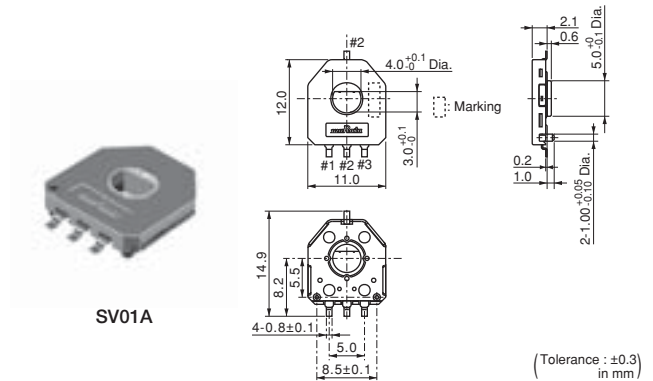

| Part Number   | Total Resistance Value (k ohm) | Linearity (%) | Effective Rotational Angle | Rotational Torque         | Rotational Life |
|---------------|--------------------------------|---------------|----------------------------|---------------------------|-----------------|
| SV01A103AEA01 | 10 ±30%                        | ±2            | 333.3° (Ref.)              | 2mN.m (Ref.:21gf.cm) max. | 1M cycles       |
| SV01L103AEA11 | 10 ±30%                        | ±2            | 333.3° (Ref.)              | 2mN.m (Ref.:21gf.cm) max. | 1M cycles       |

### ■ Constructions

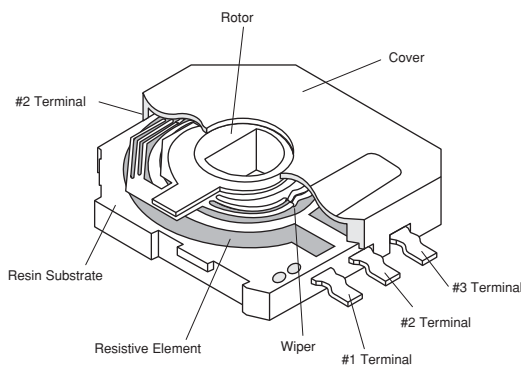



■ Standard Land Pattern

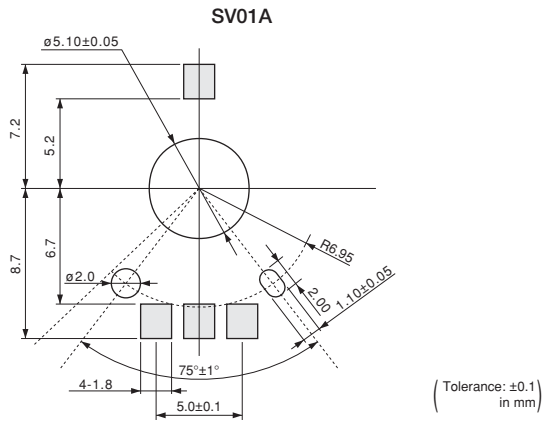

■ Standard Mounting Holes

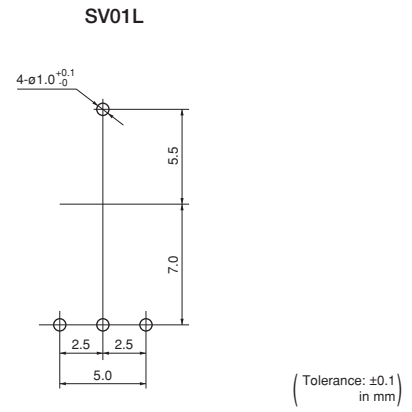

■ Characteristics

|                                      |                                 |
|--------------------------------------|---------------------------------|
| Temperature Cycle<br>(Thermal Shock) | ΔTR : ±20%<br>Linearity: ±3%    |
| Humidity                             | ΔTR : ±20%<br>Linearity: ±3%    |
| Vibration                            | ΔTR : ±10%<br>Linearity: ±3%    |
| Shock                                | ΔTR : ±10%<br>Linearity: ±3%    |
| Humidity Load Life                   | ΔTR : ±20%<br>Linearity: ±3%    |
| High Temperature<br>Exposure         | ΔTR : +5/-30%<br>Linearity: ±3% |
| Low Temperature<br>Exposure          | ΔTR : ±20%<br>Linearity: ±3%    |
| Rotational Life                      | ΔTR : ±20%<br>Linearity: ±3%    |

ΔTR: Total Resistance Change

## SV01 Series Specifications and Test Methods

The tests and measurements should be conducted under the condition of 15 to 35°C of temperature 25 to 75% of relative humidity and 86 to 106 kpa of atmospheric pressure unless otherwise specified. If questionable results occur that have been measured in accordance with the above mentioned conditions, the tests and measurements should be conducted under the condition of 25±2°C of temperature, 45 to 55% of relative humidity and 86 to 106 kpa of atmospheric pressure. When the potentiometer is tested after soldering on PCB, it should be tested after being kept in a room (15 to 35°C, 25 to 75%RH) over 24 hours except "Resistance to soldering heat".

2

| No.              | Item                              | Test Methods  |          |        |   |   |   |                  |       |       |       |       |             |    |        |    |        |
|------------------|-----------------------------------|---|----------|--------|---|---|---|------------------|-------|-------|-------|-------|-------------|----|--------|----|--------|
| 1                | Linearity                         | <p>Linearity should be specified a deviation with the below ideal straight line, between ±160° from the index point which is 50% of out put voltage.<br/>                     The ideal straight line has 100%/333.3° as taper and pass the above index point.<br/>                     Measurement is performed using the following measurement circuit, and the rotor should be rotated to clockwise direction.</p>   |          |        |   |   |   |                  |       |       |       |       |             |    |        |    |        |
| 2                | Temperature Cycle (Thermal Shock) | <p>The rotary position sensor should be subjected to Table 2 temperature for 5 cycles.<br/>                     Then, the rotary position sensor should be kept in the dry box for 24 +8/-0 hrs.</p> <table border="1"> <thead> <tr> <th>Sequence</th> <th>1</th> <th>2</th> <th>3</th> <th>4</th> </tr> </thead> <tbody> <tr> <td>Temperature (°C)</td> <td>-40±3</td> <td>+25±2</td> <td>+85±3</td> <td>+25±2</td> </tr> <tr> <td>Time (min.)</td> <td>30</td> <td>5 max.</td> <td>30</td> <td>5 max.</td> </tr> </tbody> </table> <p>Table 2: One cycle of temperature cycle</p> | Sequence | 1      | 2 | 3 | 4 | Temperature (°C) | -40±3 | +25±2 | +85±3 | +25±2 | Time (min.) | 30 | 5 max. | 30 | 5 max. |
| Sequence         | 1                                 | 2   | 3        | 4      |   |   |   |                  |       |       |       |       |             |    |        |    |        |
| Temperature (°C) | -40±3                             | +25±2   | +85±3    | +25±2  |   |   |   |                  |       |       |       |       |             |    |        |    |        |
| Time (min.)      | 30                                | 5 max.  | 30       | 5 max. |   |   |   |                  |       |       |       |       |             |    |        |    |        |
| 3                | Humidity                          | <p>The rotary position sensor should be stored in a chamber at temperature of +60±2°C and relative humidity of 90-95% for 250±8 hrs. After removing from the chamber, the rotary position sensor should be kept in the dry box for 24 +8/-0 hours.</p>  |          |        |   |   |   |                  |       |       |       |       |             |    |        |    |        |
| 4                | Vibration                         | <p>The rotary position sensor should be tested under the condition of the amplitude of 1.5mm, the frequency range from 10 to 55Hz (should be traversed in approximately one minute) and 2 hours in each of 3 mutually perpendicular directions (total 6 hours). Then, the rotary position sensor should be kept in the dry box for 1-2 hrs.</p>   |          |        |   |   |   |                  |       |       |       |       |             |    |        |    |        |
| 5                | Shock                             | <p>The rotary position sensor should be tested under the condition of the peak acceleration 20G max. in half-sine wave and 5 shocks in each of 3 mutually perpendicular directions (total 15 shocks). Then, the rotary position sensor should be kept in the dry box for 1-2 hrs.</p>   |          |        |   |   |   |                  |       |       |       |       |             |    |        |    |        |
| 6                | Humidity Load Life                | <p>Full rated continuous working voltage not exceeding 5Vdc should be applied intermittently between terminal #1 and terminal #3 of the rotary position sensor, 1.5 hours on and 0.5 hours off, for 96±4 hours in total in a chamber at a temperature of +40±2°C and relative humidity of 90-95%. After removing from the chamber, the rotary position sensor should be kept in the dry box for 24 +8/-0 hours.</p>   |          |        |   |   |   |                  |       |       |       |       |             |    |        |    |        |
| 7                | High Temp. Exposure               | <p>The rotary position sensor should be stored in a chamber at the temperature of +85±3°C without loading for 250±8 hours. After removing from the chamber, the rotary position sensor should be kept in the dry box for 24 +8/-0 hours.</p>  |          |        |   |   |   |                  |       |       |       |       |             |    |        |    |        |
| 8                | Low Temp. Exposure                | <p>The rotary position sensor should be stored in a chamber at the temperature of -40±3°C without loading for 168±4 hours. After removing from the chamber, the rotary position sensor should be kept in the dry box for 24 +8/-0 hours.</p>  |          |        |   |   |   |                  |       |       |       |       |             |    |        |    |        |
| 9                | Rotational Life                   | <p>The adjustment rotor should be continuously rotated within ±160° of effective electrical rotational angle, at the rate of one cycle for 6 seconds for 1 Million cycles under the condition of +25±2°C of temperature without loading.</p>  |          |        |   |   |   |                  |       |       |       |       |             |    |        |    |        |

## SV Series Notice

### ■ Notice (Operating and Storage Conditions)

1. Store in temperatures of -10 to +40deg. C and relative humidity of 30-85%.
2. Do not store in or near corrosive gases.
3. Use within six months after delivery.
4. Open the package just before using.
5. Do not store under direct sunlight.
6. Do not use the rotary position sensor under the following environmental conditions. If you use the rotary position sensor in an environment other than listed below, please consult a Murata factory representative prior to using.
  - (1) Corrosive gasses atmosphere  
(Ex. Chlorine gas, Hydrogen sulfide gas, Ammonia gas, Sulfuric acid gas, Nitric oxide gas, etc.)
  - (2) In liquid  
(Ex. Water, Oil, Medical liquid, Organic solvent, etc.)
  - (3) Dusty / dirty atmosphere
  - (4) Direct sunlight
  - (5) Static voltage nor electric/magnetic fields
  - (6) Direct sea breeze
  - (7) Other variations of the above

### ■ Notice (Soldering and Mounting)

1. Soldering
  - (1) SV01 series can be soldered by reflow soldering method and soldering iron. Do not use flow soldering method (dipping).
  - (2) The dimension of land pattern used should be Murata's standard land pattern at reflow soldering. Excessive land area may cause displacement due to the effect of the surface tension of the solder. Insufficient land area may cause insufficient soldering strength on PCB (SMD Type).
  - (3) Soldering conditions  
Refer to the temperature profile.  
If the soldering conditions are not suitable, e.g., excessive time and/or excessive temperature, the rotary position sensor may deviate from the specified characteristics.
  - (4) The amount of solder is critical. Insufficient amounts of solder can lead to insufficient soldering strength on PCB. Excessive amounts of solder may cause bridging between the terminals.
  - (5) The soldering iron should not come in contact with the cover of the rotary position sensor. If such contact does occur, the rotary position sensor may be damaged.
2. Mounting
  - (1) Use PCB hole to meet the pin of the rotary position sensor. If the rotary position sensor is inserted into insufficient PCB hole, the rotary position sensor may be damaged by mechanical stress (Lead type).
  - (2) Do not apply excessive force, preferable 9.8N max. (Ref. 1kgf) when the rotary position sensor is mounted to the PCB.
  - (3) Do not warp and/or bend PCB to prevent the rotary position sensor from breakage.
3. Cleaning  
Cannot be cleaned because of open construction.

Continued on the following page. 

## SV Series Notice

☐ Continued from the preceding page.

### ■ Soldering Profile

#### ● Reflow Soldering Profile

1. Soldering profile for Lead-free solder (96.5Sn/3.0Ag/0.5Cu)

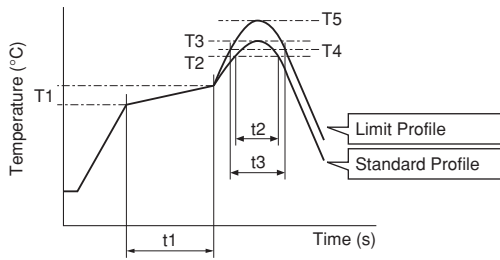

| Series | Standard Profile |           |            |           |                       |                 | Limit Profile |           |            |           |                       |                 |
|--------|------------------|-----------|------------|-----------|-----------------------|-----------------|---------------|-----------|------------|-----------|-----------------------|-----------------|
|        | Pre-heating      |           | Heating    |           | Peak Temperature (T3) | Cycle of Reflow | Pre-heating   |           | Heating    |           | Peak Temperature (T5) | Cycle of Reflow |
|        | Temp. (T1)       | Time (t1) | Temp. (T2) | Time (t2) |                       |                 | Temp. (T1)    | Time (t1) | Temp. (T4) | Time (t3) |                       |                 |
| °C     | sec.             | °C        | sec.       | °C        | Time                  | °C              | sec.          | °C        | sec.       | °C        | Time                  |                 |
| SV     | 150 to 180       | 60 to 120 | 220        | 30 to 60  | 245±3                 | 2               | 150 to 180    | 60 to 120 | 230        | 30 to 50  | 260 +5/-0             | 2               |

2. Soldering profile for Eutectic solder (63Sn/37Pb)

(Limit profile: refer to 1)

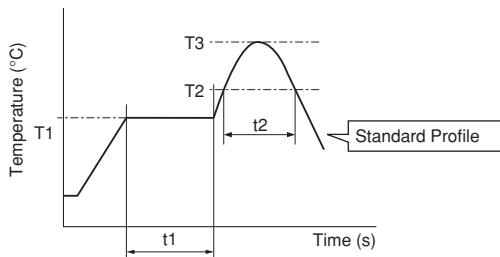

| Series | Standard Profile |           |            |           |                       |                 |
|--------|------------------|-----------|------------|-----------|-----------------------|-----------------|
|        | Pre-heating      |           | Heating    |           | Peak Temperature (T3) | Cycle of Reflow |
|        | Temp. (T1)       | Time (t1) | Temp. (T2) | Time (t2) |                       |                 |
| °C     | sec.             | °C        | sec.       | °C        | Time                  |                 |
| SV     | 150              | 60 to 120 | 183        | 30        | 230                   | 1               |

#### ● Soldering Iron

| Series | Standard Condition                |                |                             |                         |
|--------|-----------------------------------|----------------|-----------------------------|-------------------------|
|        | Temperature of Soldering Iron Tip | Soldering Time | Soldering Iron Power Output | Cycle of Soldering Iron |
|        | °C                                | sec.           | W                           | Time                    |
| SV     | 350±10                            | 3 max.         | 30 max.                     | 1                       |

#### ■ Notice (Handling)

Uncontrolled mechanical force (except usual rotation on the hollow rotor of product) may cause a change of electrical characteristics, an increase of rotational torque or mechanical damage of the product. Therefore, please consider the following points for your design.

1. The product must be soldered by the terminals. Do not affix by screw clamping to support board as this could cause mechanical deformation.
2. The connecting shaft must be sustained by the bearing. No uncontrolled force should be applied to the hollow rotor.

#### ■ Notice (Other)

1. Please make sure the connecting impedance is not less than 1M ohm. The rotary position sensor is designed to connect the output terminal and A/D port of the microprocessor directly. Therefore, connecting impedance presupposes certain M ohm and the contact resistance is set high.
2. To minimize processing errors and rare cases of noise influence when data is installed, please consider the following when programming your software.

- (1) Data install should be done plural times and applied the mean value.
- (2) Data considered as error should be invalid.
- (3) If suspicious data is found, the data should be re-installed.
3. Before using rotary position sensor, please test after assembly in your particular mass production system.
4. MURATA cannot guarantee rotary position sensor integrity when used under conditions other than those specified in this document.

## SV Series Packaging

### ■ Minimum Quantity

| Part Number   | Minimum Quantity (pcs.) |             |           |          |      |      |
|---------------|-------------------------|-------------|-----------|----------|------|------|
|               | ø180mm reel             | ø330mm reel | Ammo Pack | Magazine | Bulk | Tray |
| SV01A103AEA01 | —                       | 1000        | —         | —        | 50   | —    |
| SV01L103AEA01 | —                       | —           | —         | —        | —    | 1000 |
| SV03A103AEA01 | —                       | 1000        | —         | —        | 50   | —    |
| SV03L103AEA01 | —                       | —           | —         | —        | —    | 1000 |

### ■ Dimensions of Reel

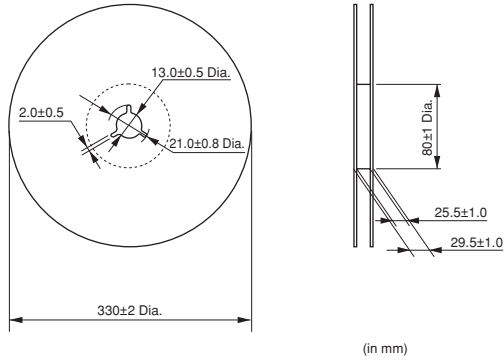

### ■ Dimensions of Plastic Tape

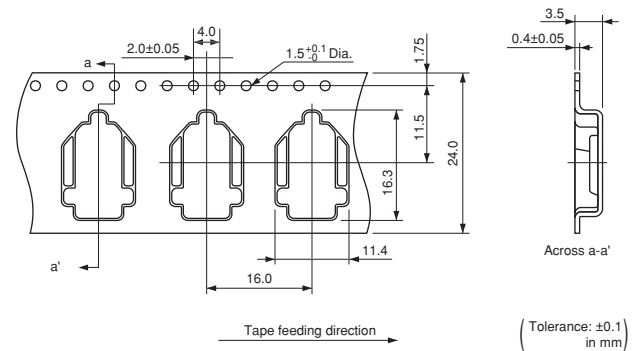

# SV Series Application Manual

## 1. Storage

- The electrodes of each SV series rotary position sensor (hereafter called "product") are plated to ensure solderability.
- However, if a product is exposed to high temperature and humidity, sulfur gas, or other contaminated environment, the surface of the electrodes may oxidize or sulfidize, resulting in defective soldering.
- The following are the precautions to be observed concerning storage management, so please refer to them.

### (1) Storage Environment

Ensure that the atmosphere is within a temperature range of between -10 and 40°C, and a humidity range of between 30 and 85%RH, and does not contain chlorine, sulfur, or other corrosive gas. Also, avoid storing the products in a location that is exposed to direct sunlight.

### (2) Storage Method

Store products in a condition such that the minimum packing boxes are not subjected to a load. Do not stack the boxes to the extent that the bottom box becomes deformed under the weight of the boxes stacked on top of it.

### (3) Storage Period

Use products within 6 months after they are shipped from us. If you use products after 6 months have elapsed, carry out a solderability test to make sure that there is no problem prior to use.

## 2. Board Design

### <1> SMD Components

#### (1) Land Pattern (use recommend land pattern only)

When a land pattern area that is greater than necessary is used, a positional error or rotation of the product may occur due to the effect of the surface tension of the solder, which may result in trouble when the product is connected to a mechanical part.

Also, if the land pattern area is too small, the force bonding the product to the printed circuit board will be low, which may result in the product separating from the board.

In order to prevent the above trouble, please use our standard land pattern.

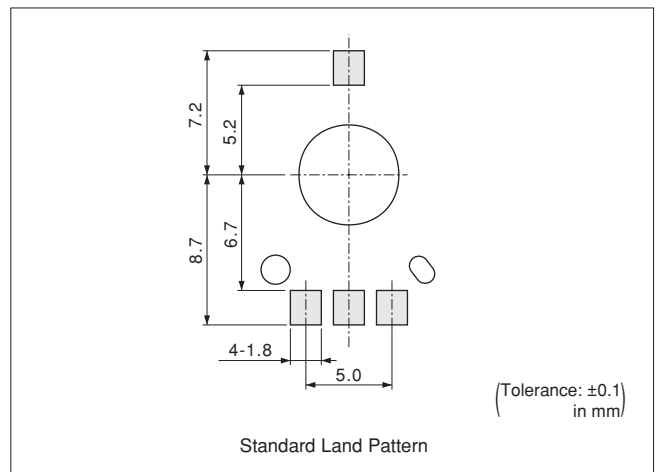

This product has two #2 terminals, at positions A and B to ensure flexibility of mounting on the board to cope with various wiring layouts.

This permits "in-line use" in which the #1 and #3 terminals are connected with the #2 terminal on the same side (A), or "zigzag alignment use" in which the #2 terminal on the B side is connected to the circuit. In the case of "in-line use" as well, be sure to provide a land for the #2 terminal on the B side in order to ensure that the product is fixed to the board with adequate force.

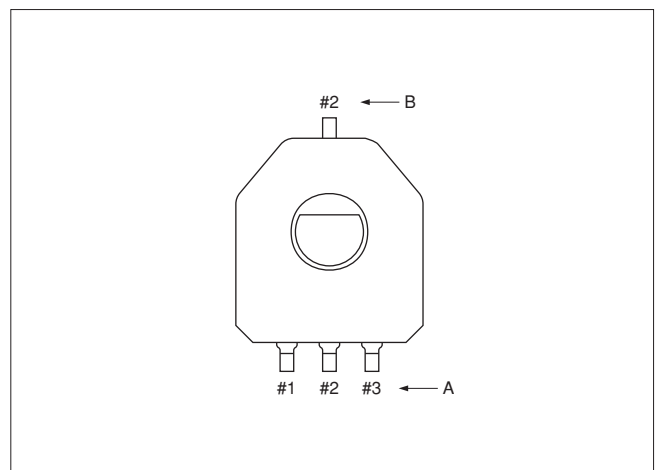

Continued on the following page. ↗

**SV Series Application Manual**

☐ Continued from the preceding page.

(2) Locating Holes on Print Circuit Board

The mounting position of the product is determined by the holes in the following three places.

- ① Center position (X-and Y-directions) is determined by Hole (one location) for boss at rear of product.
- ② Rotation angle ( $\theta$  angle) is determined by hole(s) for locating pins at rear of product. ( $\theta$ -angle can be fixed by one hole or two holes.)

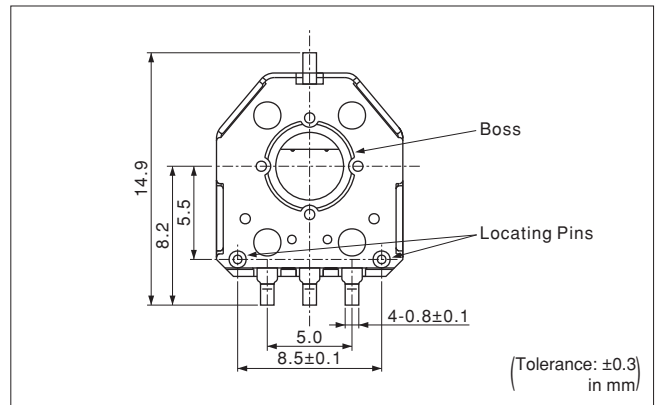

Determine the dimension of the locating holes as follows, depending upon the method of mounting the product (when mounting the product using a mounter or mounting it by hand).

- ① When mounting the product by hand

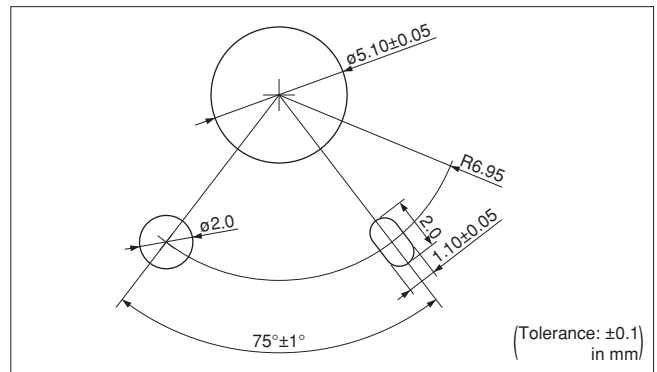

- ② When using a mounter

Expand the size of each hole to account for the accuracy of the mountes.

Note, however, that the accuracy of the mounting position of the product is determined by the "accuracy of the mounter".

<2> Leaded Parts

(1) Thru-holes

Determine the thru-hole positions so as to match the terminal pitch of the product. If you attempt to mount the product into thru-holes that do not match the terminal pitch, the terminals may become deformed and in the worst case may break. Also, random variations in the mounting position of the product may occur.

In order to prevent the above trouble, use our standard thru-hole dimensions.

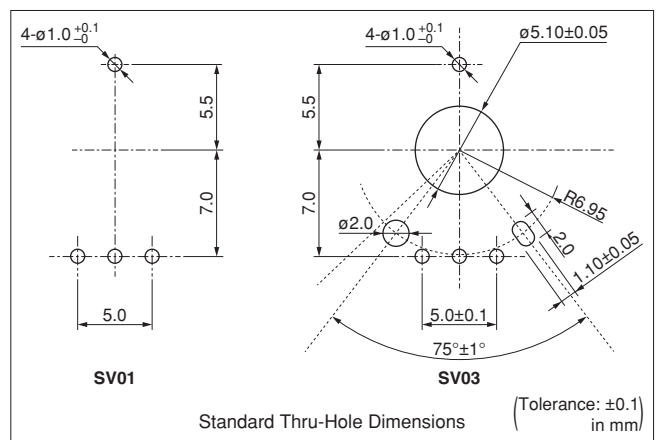

(2) Positioning Accuracy

Compared to an SMD product, there is a tendency for large variations in the mounting position of the product to occur. If positioning accuracy is important when making connection to a mechanical part, we recommend that you use an SMD product.

## SV Series Application Manual

☐ Continued from the preceding page.

### 3. Circuit Design

#### (1) Recommended Circuit

- This product is designed on the assumption that it is to be used with the output terminals directly connected to the A/D port of a microprocessor as shown in Fig.1. In other words, the contact resistance inside the product is slightly high based on the assumption that the connection impedance value is of the order of megohms. Consequently, when using the product in the circuit of Fig.2, take steps to ensure that the connection impedance does not fall below 1MΩ.  
 (Refer to sub-section 3 of 8. Examples of Actual Trouble and Preventive Measures.)

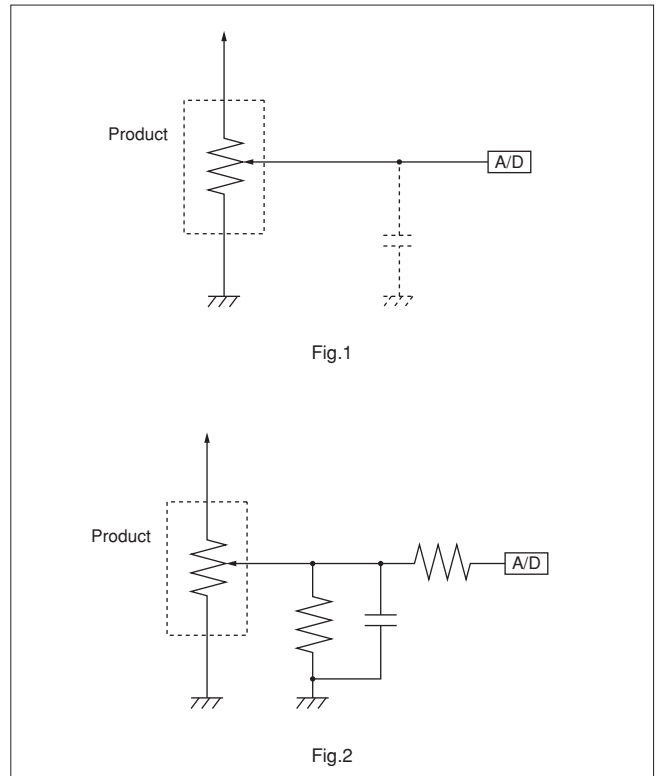

#### (2) Avoid inserting a fixed resistor in series with the sensor.

- Because the resistive element used in this product is a "carbon resistive element", its temperature characteristics cause its total resistance value to change with the ambient temperature. The total resistance also changes due to changes in the external environment along with the passage of time. However, the resistance of each parts of the resistive element changes uniformly, so the "output voltage characteristics" which are determined by the voltage division ratio due to the contact point will not be greatly affected.
- Note, however, that if fixed resistors are connected in series with the product as shown in the figure at right, the "output voltage characteristics" may be adversely affected by the difference in the rate of change of the resistance of the fixed resistors and that of the resistive element of the product. For this reason, avoid connecting fixed resistor in series with the sensor.

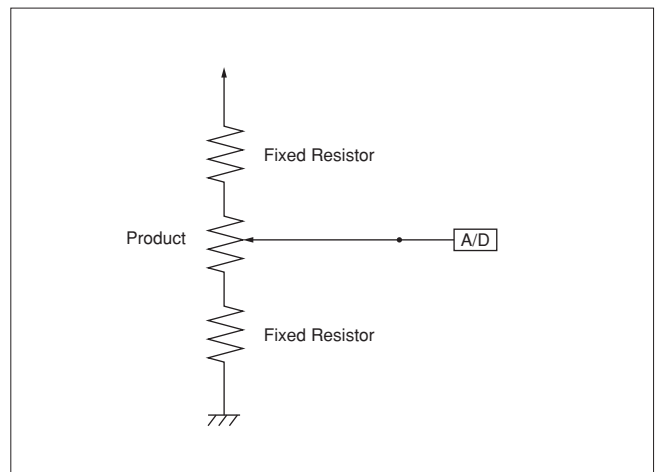

#### (3) Avoid using the product at a voltage that exceeds the rated voltage.

- If the product is used at a voltage that exceeds the rated voltage, the resulting abnormal heat generation may impair the function of the product.

Continued on the following page. ☐



☐ Continued from the preceding page.

## 4. Mechanical Design

- (1) Cross-section dimension of the shaft inserted into the rotor
- The cross-section dimension of the shaft inserted into the rotor of the product greatly affects the characteristics of the product.
  - If the dimension is too small, backlash between the product rotor and the inserted shaft will occur, which may cause a delay in the change in the output voltage accompanying the rotation of the shaft.
  - If the dimension is too large, the rotor will break, resulting in an increase in the rotational torque and also abnormal wear of the product bearing. In addition, wear dust from the bearing in which wear occurs may adversely affect the characteristics of the output voltage, and so on.

- (2) Load on the product bearing
- If a thrust, radial, or twist load, for example, is applied to the rotor bearing, the electrical characteristics may change, the rotational torque may increase, or mechanical damage may occur. When designing a system, pay attention to the following points.
    - ① Mount the product only by soldering the terminals. Avoid screwing it to an auxiliary board, for example, because this may cause deformation of the product.
    - ② The shaft that is inserted into the rotor is supported by a bearing, so do not apply a load to this bearing. (Refer to sub-section 1 of 8. Examples of Actual Trouble and Preventive Measures.)

## 5. System Design

(1) Precautions for Loading Data

Implement the following software measures in order to minimize data loading failures which occur occasionally, and also the effect of sliding noise and external noise.

- ① Perform several data loading operations and obtain the mean value.
- ② Disable data that is considered to be the cause of data loading failures.
- ③ If any doubt arises, take appropriate action such as carrying out a data acquisition operation once again.

## 6. Mounting the Product on a Printed Circuit Board and Soldering It

<1> When mounting the product with a mounter, and reflow soldering it

(1) Quantity of solder paste

- The standard coating thickness of solder paste used on SMD products is 150µm.
- If the quantity of solder is insufficient, the solder adhesion strength may be inadequate. Conversely, if there is too much solder, ① solder bridging or ② ingress of flux into the product may occur, impairing the contact condition of the electrical contacts. This in turn will result in an abnormal output voltage.
- The standard solder paste is Sn-3Ag-0.5Cu.











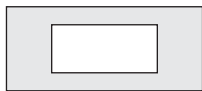

Continued on the following page. ☐

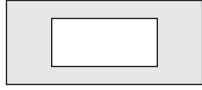
## SV Series Application Manual

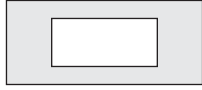
☐ Continued from the preceding page.

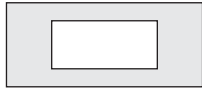
### (2) Applicable mounter

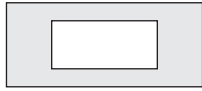
- A rotary position sensor is an "atypical component", so it is necessary to use a "placement machine suitable for this part". (Refer to the table below. For details, please contact the various mounter manufacturers.)
- The judgment concerning whether or not a particular mounter is suitable depends upon the required mounting speed and mounting position accuracy. Be sure to carry out an advance mounting check on the actual manufacturing line.

| Name of Manufacturer                  | Model Name      | Nozzle Part No./Series Name/Drawing No.   | Nozzle Shape  | Suction Position  |
|---------------------------------------|-----------------|---|---|---|
| Panasonic Factory Solutions Co., Ltd. | CM40□           | 1461 nozzle   |    |    |
|                                       | CM602           |   |   |   |
|                                       | BM Series       | 10807GK823  |   |   |
|                                       | MSF Series      | 10807GK823  |   |   |
| Yamaha Motor Co., Ltd.                | YV100X          | SKV8-M77MJ-000  |   |   |
|                                       | YV100Xg         |   |   |   |
|                                       | YV88X           | A customized nozzle of the same shape as that of the SKV8-M77MJ-000 must be newly fabricated. |   |   |
|                                       | YV88Xg          |   |   |   |
|                                       | YG100R          |   |   |   |
|                                       | YG88R           |   |   |   |
|                                       | YS100           |   |   |   |
| YS88                                  |                 |   |   |   |
| Please contact Yamaha Motor Co., Ltd. |                 |   |   |   |
| JUKI Corporation                      | KE-2060         | No.648 nozzle   |   |   |
|                                       | KE-2050         | No.648 nozzle   |   |   |
| Hitachi High-Technologies Corporation | GXH Series      | High speed head: VT14 or VG02   |  |  |
|                                       |                 | Multi-function head: WT14 or WG02   |   |   |
|                                       | TIM-5000 Series | High-speed head: VT14 or VG02   |   |   |
|                                       |                 | Multi-function head: WT14 or WG02   |   |   |
|                                       | TIM-X100        | High-speed head: VT14 or VG02   |   |   |
|                                       |                 | Multi-function head: WT14 or WG02   |   |   |
| i-PULSE Co., Ltd.                     | M2              | SLYYM1183-000   |  |  |
|                                       | M6              | SLYYM1283-000   |   |   |
|                                       | M6e             | SLYYM1083-000   |   |   |
|                                       | M2              | SLYYM112T-000   |  |  |
|                                       | M6              | SLYYM122T-000   |   |   |
|                                       | M6e             | SLYYM102T-000   |   |   |
| Fuji Machine Mfg. Co., Ltd.           | NXT, NXTII      | It is necessary to newly fabricate a customized nozzle.                                       | Please contact Fuji Machine Mfg. Co., Ltd.  |   |
|                                       | XP              |   |   |   |

### (3) Reflow Temperature Profile

The standard conditions are shown to the right.

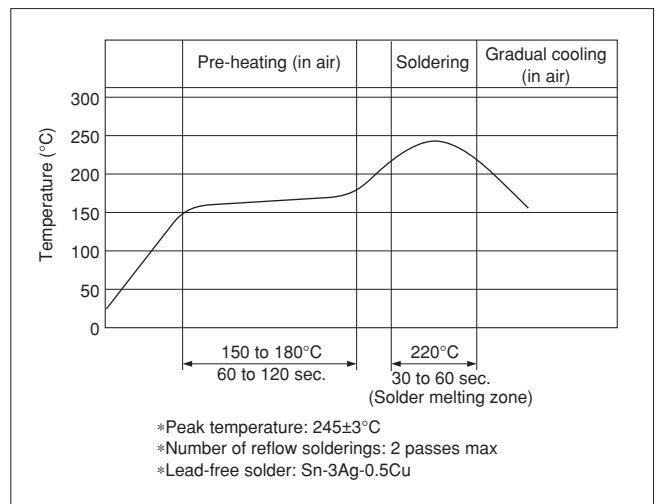

Continued on the following page. ↗

**SV Series Application Manual**

☐ Continued from the preceding page.

<2> When mounting the product by hand and soldering it with a soldering iron

(1) Quantity of Solder

- For both SMD and leaded products, supply a quantity of wire solder that is within the range where solder bridging between the terminals does not occur.
- The standard wire solder is Sn-3Ag-0.5Cu.

(2) Soldering Iron

- The standard conditions are as shown at right.

Temperature of soldering iron tip:  $350\pm 10^{\circ}\text{C}$   
Soldering time : Within 3 seconds per terminal  
Diameter of the soldering iron tip:  $\phi 3\text{mm}$  max.  
Wattage of iron : 30W max.

- When soldering, take care that the tip of the soldering iron does not come into direct contact with the product (cover, rotor, plastic substrate, etc.). If such contact does occur, the product may be damaged.

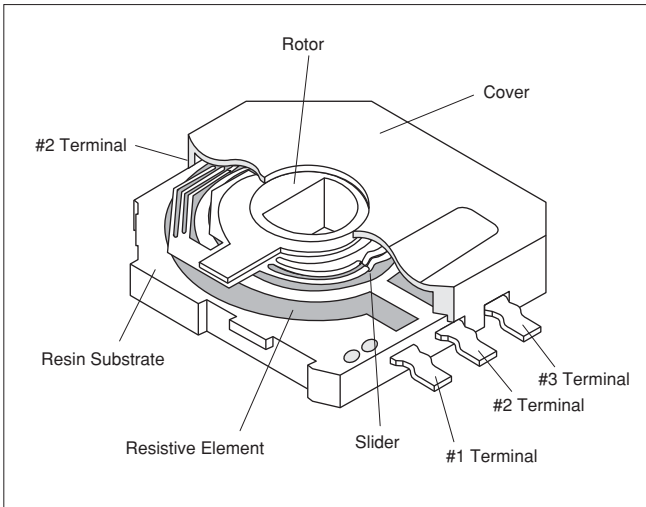

- Heat both the terminal and the land at the same time so that the wire solder melts quickly. This will reduce deformation of the resin substrate of the product due to heat transmitted from the terminals.

<3> Washing

- This product is not of a sealed construction so you cannot wash it.

**7. Connecting the Product to a Mechanical Part**

- In case of using grease or lubricant on connecting shaft or gear, please prevent grease or lubricant coming into the product. If grease or lubricant gets inside the product, the product may deviate from the specified characteristics. (Refer to sub-section 2 of 8. Examples of Actual Trouble and Preventive Measures.)
- When combining the product with a mechanical part, please, ensure that the center of the product's rotor hole coincides with the center of the shaft that is to be inserted into the rotor. (Refer to sub-section 5 of 8. Examples of Actual Trouble and Preventive Measures.)

Continued on the following page. ☐

**SV Series Application Manual**

☐ Continued from the preceding page.

**8. Examples of Actual Trouble and Preventive Measures**

**1. Do not apply a load other than rotational motion to the bearing.**

Because this product has been designed with emphasis on miniaturization and low weight, the bearing is not intended to support a load. For this reason, please, provide a separate bearing function to ensure that an excessively high load is not applied to the bearing of the product.

If a load is applied to the bearing in the radial or thrust direction, the bearing may wear, resulting in the following trouble.

- ① Deterioration of output voltage linearity due to backlash in the rotor
- ② Deterioration of the contact condition of the contacts due to wear dust

Also, be sure to carry out an evaluation using an actual machine.

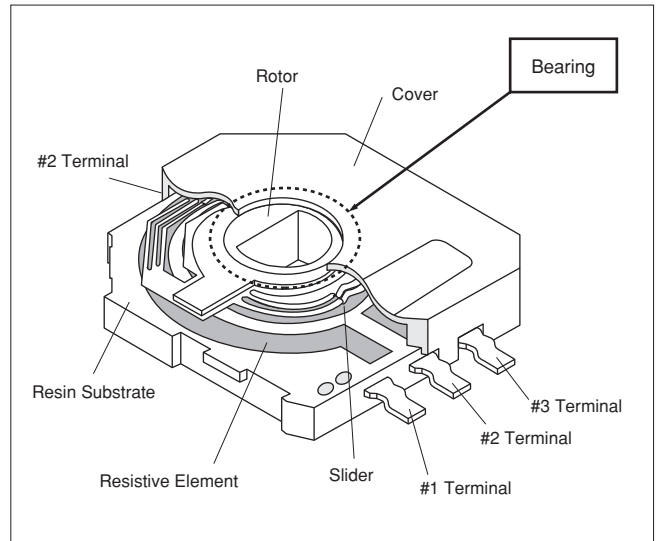

**2. Do not allow grease or other lubricant to get into the product.**

The rotational life of this product has been increased by appropriate selection of materials, processing method, and so on, without relying on lubricants. Consequently, if grease or other lubricant gets into the product, trouble is likely to occur.

This product is not of a sealed construction, so lubricant may flow into it from the bearing or gaps in the case, for example. When it is unavoidably necessary to coat a gear, or other part, that you use with grease, or another lubricant, take the following precautions to prevent grease from getting into the product.

- ① Use a high viscosity lubricant
- ② Do not allow lubricant to get onto the shaft that is to be connected to the product. (In the case of a shaft that is integral with the gear, apply lubricant only to the gear teeth.)

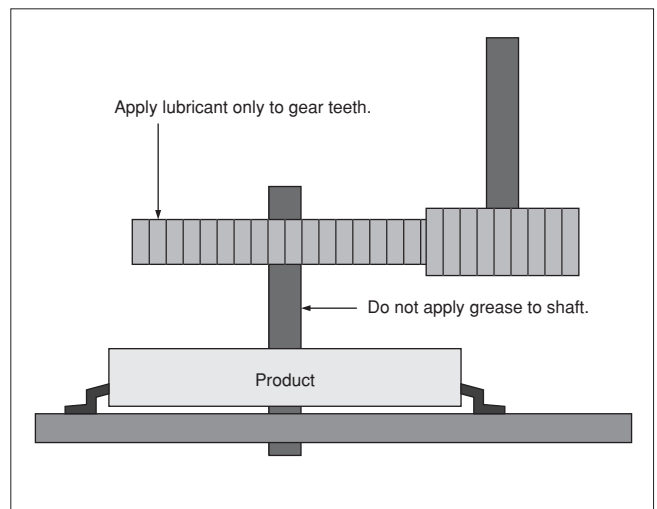

**3. Ensure that the connection impedance is at least 1MΩ.**

This product has increased contact resistance (sliding noise) in order to maximize its rotational life. Consequently, in order to reduce the effect of sliding noise, it is necessary to reduce the current flowing through the contacts (current *i* indicated in the figure at right) as far as possible. Accordingly, take steps to ensure that the internal impedance of the circuit connected to the output terminal (#2 terminal) is at least 1MΩ.

Be particularly careful in the case of the filter circuit shown in the figure at right.

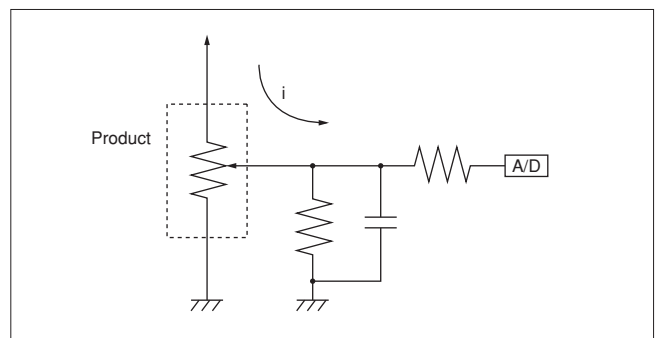

Do not rheostat connect as shown in the figure at right due to the contact resistance is slightly high.

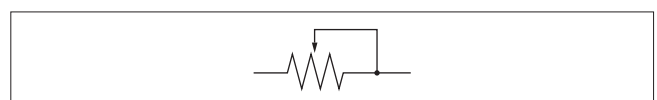

Continued on the following page. ☐

**SV Series Application Manual**

☐ Continued from the preceding page.

The graph at right shows the results of measuring the output voltage linearity of the same sample when the impedance to which it is connected is changed between 1MΩ and 200kΩ. It can be seen that the effect of sliding noise is reduced when the connection impedance is increased.

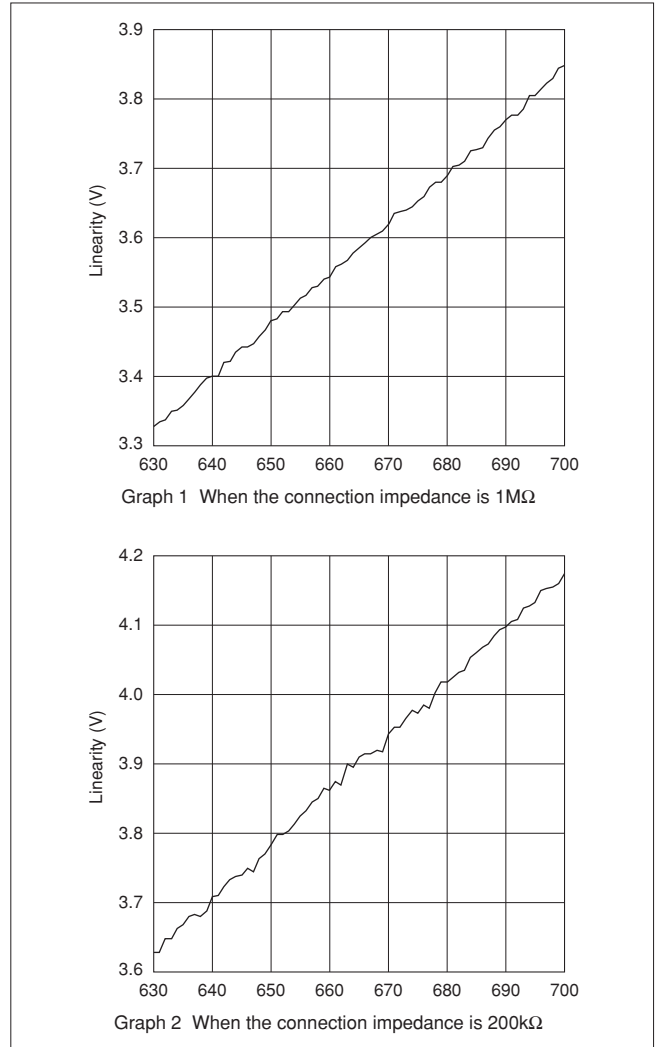

4. When using the product in an atmosphere containing a corrosive gas (chlorine, sulfur, etc.), install it in a sealed structure.

This product is not of a sealed construction, so the contacts and resistive element inside it are exposed directly to the ambient air. For this reason, if the product is used in an atmosphere containing a corrosive gas, the contacts and resistive element may corrode. When it is unavoidably necessary to use the product in an atmosphere containing a corrosive gas, install the product in a sealed structure.

5. Ensure that the positions of the mechanical part (shaft) that you wish to connect to the product and the product rotor hole do not become misaligned.

When combining a mechanical part with the product, ensure that the center of the product rotor hole coincides with the center of the shaft to be inserted into the rotor. If you use these parts in a misaligned condition, the bearing may wear, resulting in the following trouble.

- ① Deterioration of output voltage linearity due to play in the rotor
- ② Deterioration of the contact condition of the contacts due to wear dust

## Qualified Standards

### ■ Qualified Standards

The products listed here have been produced by the ISO9001 and ISO/TS16949 certified factory.

| MURATA FACTORY                  | Qualified Date | Standard                       | Qualified Number |
|---------------------------------|----------------|--------------------------------|------------------|
| Wuxi Murata Electronis Co.,Ltd. | May 12, 1999   | UNDERWRITERS LABORATORIES INC. | A7924            |

\* No ODCs (Ozone Depleting Chemicals) are used on all Murata's Rotary Position Sensors.

**⚠Note:**

1. Export Control

<For customers outside Japan>

No Murata products should be used or sold, through any channels, for use in the design, development, production, utilization, maintenance or operation of, or otherwise contribution to (1) any weapons (Weapons of Mass Destruction [nuclear, chemical or biological weapons or missiles] or conventional weapons) or (2) goods or systems specially designed or intended for military end-use or utilization by military end-users.

<For customers in Japan>

For products which are controlled items subject to the "Foreign Exchange and Foreign Trade Law" of Japan, the export license specified by the law is required for export.

2. Please contact our sales representatives or product engineers before using the products in this catalog for the applications listed below, which require especially high reliability for the prevention of defects which might directly damage a third party's life, body or property, or when one of our products is intended for use in applications other than those specified in this catalog.

- |                             |  |
|-----------------------------|--|
| ① Aircraft equipment        | ② Aerospace equipment  |
| ③ Undersea equipment        | ④ Power plant equipment  |
| ⑤ Medical equipment         | ⑥ Transportation equipment (vehicles, trains, ships, etc.)   |
| ⑦ Traffic signal equipment  | ⑧ Disaster prevention / crime prevention equipment   |
| ⑨ Data-processing equipment | ⑩ Application of similar complexity and/or reliability requirements to the applications listed above |

3. Product specifications in this catalog are as of September 2012. They are subject to change or our products in it may be discontinued without advance notice.

Please check with our sales representatives or product engineers before ordering. If there are any questions, please contact our sales representatives or product engineers.

4. Please read rating and ⚠CAUTION (for storage, operating, rating, soldering, mounting and handling) in this catalog to prevent smoking and/or burning, etc.

5. This catalog has only typical specifications. Therefore, please approve our product specifications or transact the approval sheet for product specifications before ordering.

6. Please note that unless otherwise specified, we shall assume no responsibility whatsoever for any conflict or dispute that may occur in connection with the effect of our and/or a third party's intellectual property rights and other related rights in consideration of your use of our products and/or information described or contained in our catalogs. In this connection, no representation shall be made to the effect that any third parties are authorized to use the rights mentioned above under licenses without our consent.

7. No ozone depleting substances (ODS) under the Montreal Protocol are used in our manufacturing process.

## Данный компонент на территории Российской Федерации

### Вы можете приобрести в компании MosChip.

Для оперативного оформления запроса Вам необходимо перейти по данной ссылке:

<http://moschip.ru/get-element>

Вы можете разместить у нас заказ для любого Вашего проекта, будь то серийное производство или разработка единичного прибора.

В нашем ассортименте представлены ведущие мировые производители активных и пассивных электронных компонентов.

Нашей специализацией является поставка электронной компонентной базы двойного назначения, продукции таких производителей как XILINX, Intel (ex.ALTERA), Vicor, Microchip, Texas Instruments, Analog Devices, Mini-Circuits, Amphenol, Glenair.

Сотрудничество с глобальными дистрибьюторами электронных компонентов, предоставляет возможность заказывать и получать с международных складов практически любой перечень компонентов в оптимальные для Вас сроки.

На всех этапах разработки и производства наши партнеры могут получить квалифицированную поддержку опытных инженеров.

Система менеджмента качества компании отвечает требованиям в соответствии с ГОСТ Р ИСО 9001, ГОСТ РВ 0015-002 и ЭС РД 009

### Офис по работе с юридическими лицами:

105318, г.Москва, ул.Щербаковская д.3, офис 1107, 1118, ДЦ «Щербаковский»

Телефон: +7 495 668-12-70 (многоканальный)

Факс: +7 495 668-12-70 (доб.304)

E-mail: [info@moschip.ru](mailto:info@moschip.ru)

Skype отдела продаж:

moschip.ru

moschip.ru\_4

moschip.ru\_6

moschip.ru\_9