

BCM53112

15-Port Integrated Fast Ethernet Switch with High-Speed 1GbE/2.5GbE SGMII Uplink Interfaces

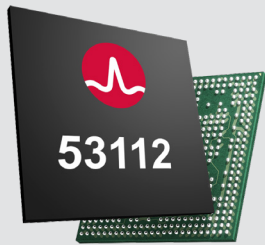

Key Features

- Eight 10/100BASE-T ports with integrated EPHYs.
- Four 100FX/1000FX (SGMII) ports.
- Two 100FX/1000FX/2500FX (SGMII+) ports.
- An integrated ARM Cortex-M7 CPU.
- An RGMII, MII, and RvMII port to connect to an external CPU.
- Cascading that enables the creation of unified, single-CPU managed, 15- to 28-port switch.
- Support for advanced QoS, CFP, VLAN manipulation, up to L4 classification via CFP, and TSN.
- Support for the IEEE 802.1BR port extender.
- Power-saving green technology per IEEE 802.3az Energy Efficient Ethernet.
- Support for industrial (-40°C to +85°C) ambient temperature.

Applications

- Industrial Ethernet
- Unmanaged/web-managed/managed SMB switches
- Home gateway

Description

The Broadcom® BCM53112 is a highly integrated, Fast Ethernet (FE) switch designed for high-end FE applications such as next-generation Industrial Ethernet and Time Sensitive Networks (TSNs). With eight 10/100BASE-T ports (with integrated EPHYs), four 100FX/1000FX SGMII ports, and an additional two 1GbE/2.5GbE SGMII+ ports, the switch is optimally designed for 100 Mb/s and Hybrid-speed SMB and Industrial applications that take advantage of high-speed uplinks connectivity, both copper and fiber.

The BCM53112 is based on the industry-leading 28 nm RoboSwitch™ architecture, also known as Robo-2. The switch integrates a powerful ARM Cortex-M7 CPU that enables a customer to design complete SMB and Industrial platforms without relying on external processors. The switch is also equipped with high-end blocks that are required in many advanced applications. It includes an advanced QoS mechanism, a flexible compact filter processor (CFP), sophisticated VLAN manipulation capability, security features, packet synchronization for time-sensitive networks, and more.

The BCM53112 can be used with various software solutions designed for a multitude of applications. It can be used with basic, unmanaged software to design unmanaged switches that require no advanced functionality or VLAN segregation. It can be used with web-managed software to construct a high-end web-controlled switch and with a fully featured SDK software suite to design managed devices that are controlled by an external CPU.

The BCM53112 can be used to design standalone platforms with a low port-count configuration (up to 15 ports) or as part of a cascaded solution that uses two back-to-back switches with up to 26 front-facing ports, managed as a single switch entity. The switch is offered in commercial-grade ambient temperature.

Benefits

- Support for cascading mode that enables the creation of a unified, 16- to 26-port switch, unmanaged or managed by a single CPU.
- Support for QoS with hierarchical scheduling, eight egress buffer queues per-port each with its own shaper, WRED and Tail-drop congestion avoidance, and dual *leaky bucket* ingress rate limiters (such as policers).
- Advanced CFP (such as an access-list engine) that can classify up to L4 headers, supporting up to 1K rules.
- Support for virtual switching instances (VSI) for explicit segregation of bridging domains with advanced VLAN translation and encapsulation (for example, MAC-in-MAC).

Benefits (con't)

- Port-extender support, per IEEE 802.1BR, for designing modular chassis devices or *pizza box* platforms with remote port extensions.
- Advanced TSN protocol support, such as IEEE 802.1Qav, 802.1Qbv, 802.1ASrev, and 802.1Qci, for scheduling time-critical traffic streams across an entire network domain.
- Delivered with unmanaged software, web-managed software, or two different managed SDK software packages (RoboSwitch SDK and Network Switch SDK).

BCM53112 Block Diagram

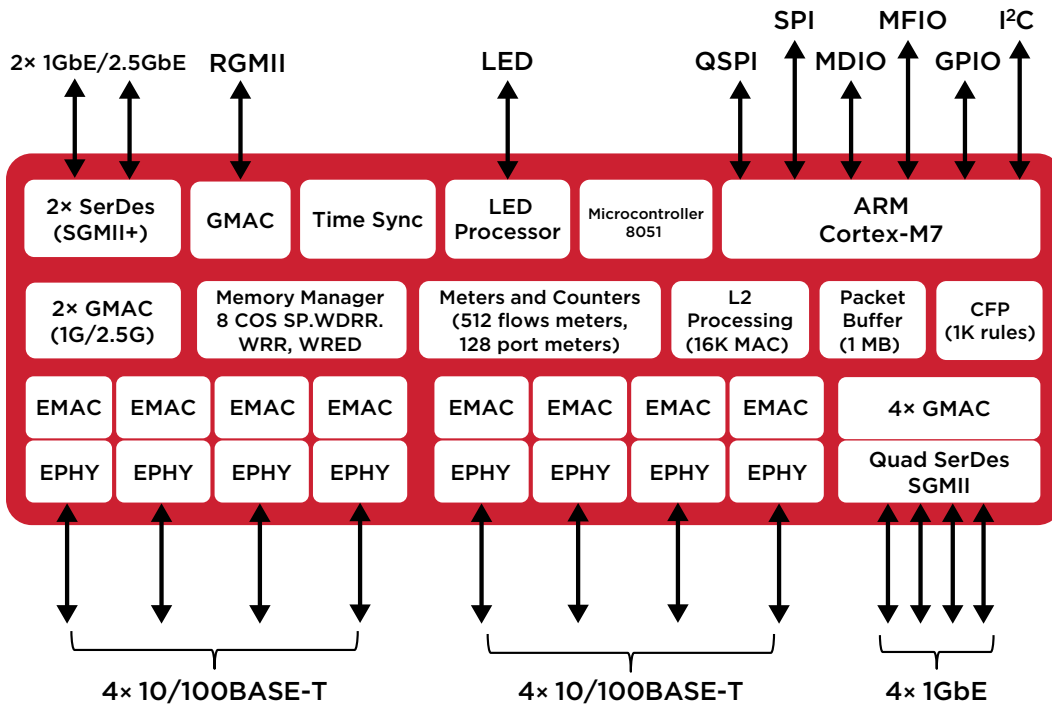

Ordering Information

Description	Ambient Temperature	Package	Device ID
Intelligent, managed FE Robo-2 switch with 8x 10/100BASE-T ports with integrated EPHYs + 4x 100FX/1000FX SGMII ports + 2x 1000FX/2500FX SGMII+ ports	Industrial (-40°C to +85°C)	19 mm x 19 mm	BCM53112MBOILFBG

Данный компонент на территории Российской Федерации

Вы можете приобрести в компании MosChip.

Для оперативного оформления запроса Вам необходимо перейти по данной ссылке:

<http://moschip.ru/get-element>

Вы можете разместить у нас заказ для любого Вашего проекта, будь то серийное производство или разработка единичного прибора.

В нашем ассортименте представлены ведущие мировые производители активных и пассивных электронных компонентов.

Нашей специализацией является поставка электронной компонентной базы двойного назначения, продукции таких производителей как XILINX, Intel (ex.ALTERA), Vicor, Microchip, Texas Instruments, Analog Devices, Mini-Circuits, Amphenol, Glenair.

Сотрудничество с глобальными дистрибьюторами электронных компонентов, предоставляет возможность заказывать и получать с международных складов практически любой перечень компонентов в оптимальные для Вас сроки.

На всех этапах разработки и производства наши партнеры могут получить квалифицированную поддержку опытных инженеров.

Система менеджмента качества компании отвечает требованиям в соответствии с ГОСТ Р ИСО 9001, ГОСТ РВ 0015-002 и ЭС РД 009

Офис по работе с юридическими лицами:

105318, г.Москва, ул.Щербаковская д.3, офис 1107, 1118, ДЦ «Щербаковский»

Телефон: +7 495 668-12-70 (многоканальный)

Факс: +7 495 668-12-70 (доб.304)

E-mail: info@moschip.ru

Skype отдела продаж:

moschip.ru

moschip.ru_4

moschip.ru_6

moschip.ru_9