

# Plastic Infrared Emitting Diode

OP165, OP166 Series



## Features:

- T-1 (3 mm) package style
- Choice of narrow or wide irradiance pattern
- Choice of dome lens or flat lens
- Mechanically and spectrally matched to other OPTEK devices
- Higher power output than GaAs at equivalent drive currents



## Description:

Each device in the **OP165** and **OP166** series is a high intensity gallium arsenide infrared emitting diode (GaAIAs) that is molded in an IR transmissive clear epoxy package with either a dome or flat lens. Devices feature narrow and wide irradiance patterns and a variety of electrical characteristics. The small T-1 package style makes these devices ideal for space-limited applications.

*OP165 and OP166 devices are mechanically and spectrally matched to the OP505 and OP535 series devices.*

*Please refer to Application Bulletins 208 and 210 for additional design information and reliability (degradation) data.*

## Applications:

- Space-limited applications
- Applications requiring coupling efficiency

Ordering Information					
Part Number	LED Peak Wavelength	Output Power (mW/cm <sup>2</sup> ) Min / Max	I <sub>F</sub> (mA) Typ / Max	Total Beam Angle	Lead Length
OP165A	935 nm	1.95 / NA	20 / 50	18°	0.50"
OP165B		1.40 / 2.20			
OP165C		0.85 / 1.60			
OP165D		0.28 / NA		90°	
OP165W		0.50 / NA			
OP166A		1.95 / NA		18°	
OP166B		1.40 / 2.20			
OP166W		0.50 / NA			



RoHS

## General Note

TT Electronics reserves the right to make changes in product specification without notice or liability. All information is subject to TT Electronics' own data and is considered accurate at time of going to print.

OPTEK Technology, Inc.  
1645 Wallace Drive, Carrollton, TX 75006 | Ph: +1 972 323 2200  
www.optekinc.com | www.ttelectronics.com

# Plastic Infrared Emitting Diode

## OP165, OP166 Series



### OP165 (A, B, C, D)

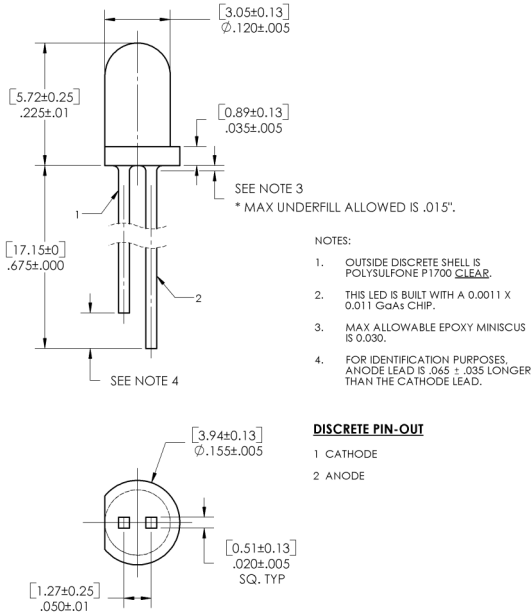

### OP165W

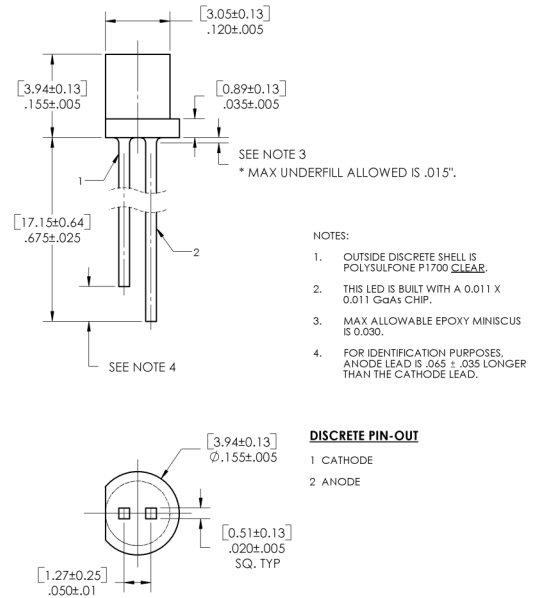

DIMENSIONS ARE IN: [MILLIMETERS]  
INCHES

### OP166 (A, B)

\* MAX UNDERFILL ALLOWED IS .015".  
\*\* ELBOW OF LEADFRAME NOT MORE THAN .005" FROM FLANGE.

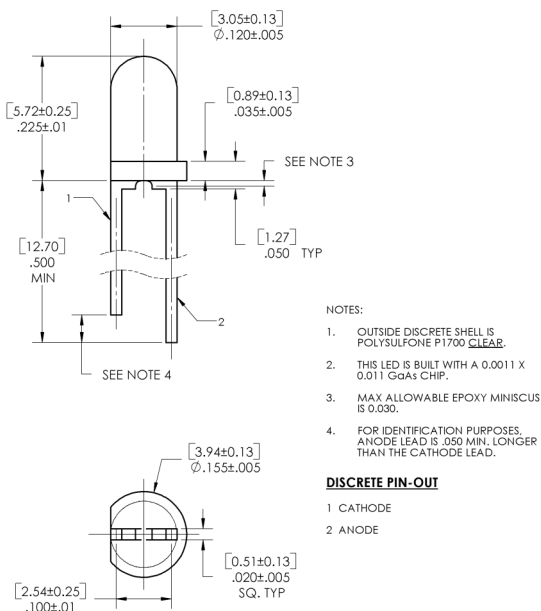

### OP166W

\* MAX UNDERFILL ALLOWED IS .015".  
\*\* ELBOW OF LEADFRAME NOT MORE THAN .005" FROM FLANGE.

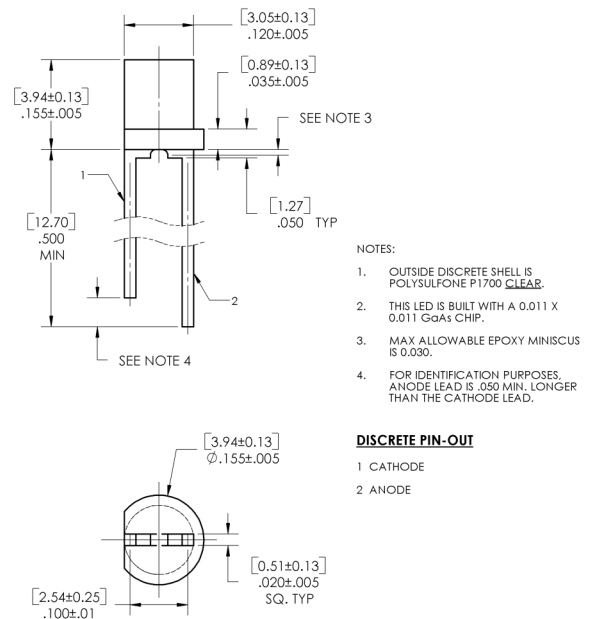

Pin #	LED
1	Cathode
2	Anode

#### CONTAINS POLYSULFONE

To avoid stress cracking, we suggest using ND Industries' **Vibra-Tite** for thread-locking. **Vibra-Tite** evaporates fast without causing structural failure in OPTEK'S molded plastics.

#### General Note

TT Electronics reserves the right to make changes in product specification without notice or liability. All information is subject to TT Electronics' own data and is considered accurate at time of going to print.

OPTEK Technology, Inc.  
1645 Wallace Drive, Carrollton, TX 75006 | Ph: +1 972 323 2200  
www.optekinc.com | www.ttelectronics.com

# Plastic Infrared Emitting Diode

OP165, OP166 Series



## Electrical Specifications

Absolute Maximum Ratings (T <sub>A</sub> = 25° C unless otherwise noted)	
Storage and Operating Temperature Range	-40° C to +100° C
Reverse Voltage	2.0 V
Continuous Forward Current	50 mA
Peak Forward Current (1 μs pulse width, 300 pps)	3.0 A
Lead Soldering Temperature [1/16 inch (1.6 mm) from case for 5 seconds with soldering iron]	260° C
Power Dissipation	100 mW <sup>(1)</sup>

Electrical Characteristics (T <sub>A</sub> = 25° C unless otherwise noted)						
SYMBOL	PARAMETER	MIN	TYP	MAX	UNITS	TEST CONDITIONS
<b>Input Diode</b>						
E <sub>E (APT)</sub>	Apertured Radiant Incidence OP165A, OP166A	1.95	-	-	mW/cm <sup>2</sup>	I <sub>F</sub> = 20 mA <sup>(2)</sup>
P <sub>O</sub>	Radiant Power Output OP165W, OP166W	0.50	-	-	mW	I <sub>F</sub> = 20 mA
V <sub>F</sub>	Forward Voltage	-	-	1.60	V	I <sub>F</sub> = 20 mA
I <sub>R</sub>	Reverse Current	-	-	100	μA	V <sub>R</sub> = 2 V
λ <sub>p</sub>	Wavelength at Peak Emission	-	935	-	nm	I <sub>F</sub> = 10 mA
B	Spectral Bandwidth between Half Power Points	-	50	-	nm	I <sub>F</sub> = 10 mA
Δλ <sub>p</sub> /ΔT	Spectral Shift with Temperature OP165, OP166 (A, B, C, D) OP165W, OP166W	-	-	-	nm/°C	I <sub>F</sub> = Constant
θ <sub>HP</sub>	Emission Angle at Half Power Points OP165, OP166 (A, B, C, D) OP165W, OP166W	-	18	-	Degree	I <sub>F</sub> = 20 mA
t <sub>r</sub>	Output Rise Time	-	1000	-	ns	I <sub>F(PK)</sub> = 100 mA, PW = 10 μs, D.C. = 10.0%
Notes:	Output Fall Time	-	500	-	ns	

- Derate linearly 1.33 mW/°C above 25°C
- E<sub>E(APT)</sub> is a measurement of the average apertured radiant incidence upon a sensing area 0.081" (2.06 mm) in diameter, perpendicular to and centered on the mechanical axis of the lens, and 0.590" (14.99 mm) from the measurement surface. E<sub>E(APT)</sub> is not necessarily uniform within the measured areas.

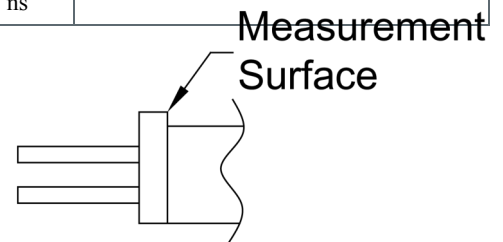

General Note  
TT Electronics reserves the right to make changes in product specification without notice or liability. All information is subject to TT Electronics' own data and is considered accurate at time of going to print.

OPTEK Technology, Inc.  
1645 Wallace Drive, Carrollton, TX 75006 | Ph: +1 972 323 2200  
www.optekinc.com | www.ttelectronics.com

# Plastic Infrared Emitting Diode

OP165, OP166 Series



## Performance

OP165, OP166 (A, B, C, D, W)

Forward Voltage vs Forward Current vs Temperature

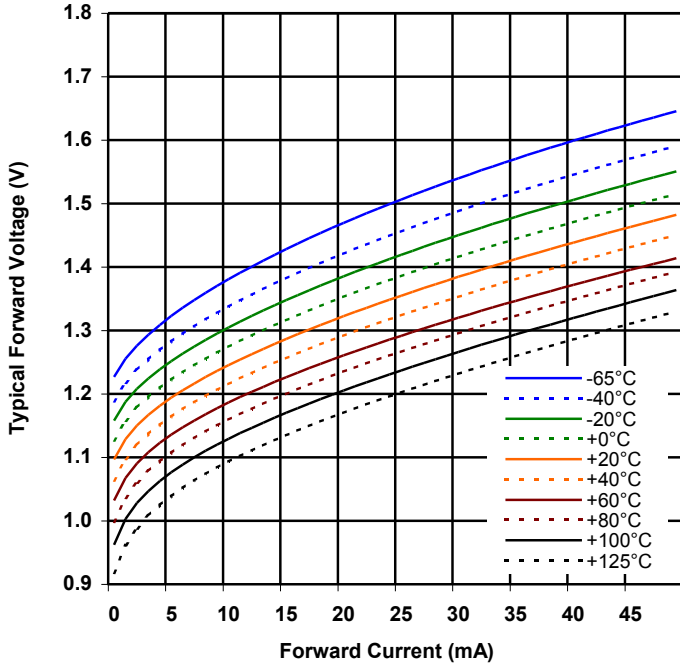

Optical Power vs  $I_F$  vs Temp

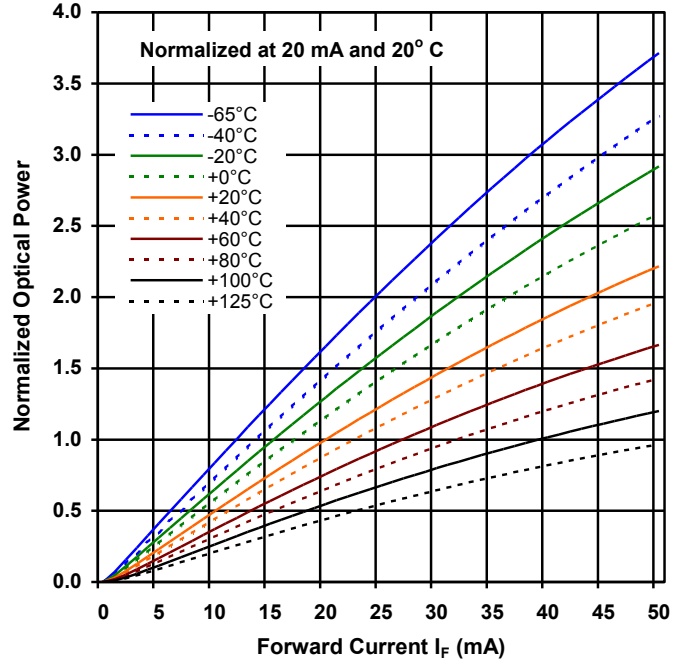

Distance vs Output Power vs Forward Current

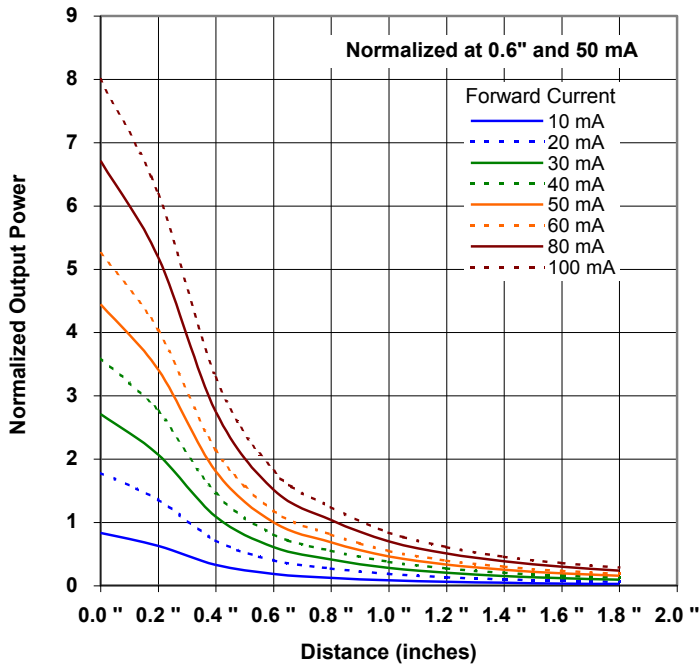

Relative Radiant Intensity vs Angular Displacement

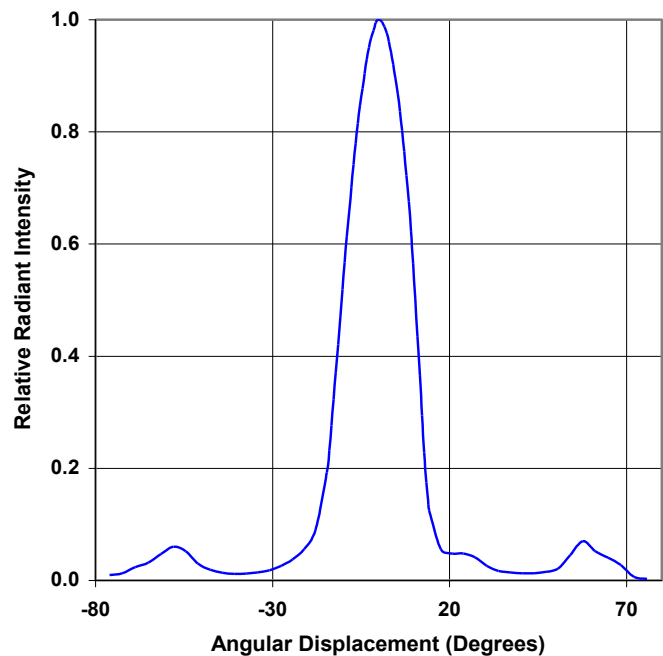

**General Note**

TT Electronics reserves the right to make changes in product specification without notice or liability. All information is subject to TT Electronics' own data and is considered accurate at time of going to print.

OPTEK Technology, Inc.  
1645 Wallace Drive, Carrollton, TX 75006 | Ph: +1 972 323 2200  
www.optekinc.com | www.ttelectronics.com

## Данный компонент на территории Российской Федерации

### Вы можете приобрести в компании MosChip.

Для оперативного оформления запроса Вам необходимо перейти по данной ссылке:

<http://moschip.ru/get-element>

Вы можете разместить у нас заказ для любого Вашего проекта, будь то серийное производство или разработка единичного прибора.

В нашем ассортименте представлены ведущие мировые производители активных и пассивных электронных компонентов.

Нашей специализацией является поставка электронной компонентной базы двойного назначения, продукции таких производителей как XILINX, Intel (ex.ALTERA), Vicor, Microchip, Texas Instruments, Analog Devices, Mini-Circuits, Amphenol, Glenair.

Сотрудничество с глобальными дистрибьюторами электронных компонентов, предоставляет возможность заказывать и получать с международных складов практически любой перечень компонентов в оптимальные для Вас сроки.

На всех этапах разработки и производства наши партнеры могут получить квалифицированную поддержку опытных инженеров.

Система менеджмента качества компании отвечает требованиям в соответствии с ГОСТ Р ИСО 9001, ГОСТ РВ 0015-002 и ЭС РД 009

### Офис по работе с юридическими лицами:

105318, г.Москва, ул.Щербаковская д.3, офис 1107, 1118, ДЦ «Щербаковский»

Телефон: +7 495 668-12-70 (многоканальный)

Факс: +7 495 668-12-70 (доб.304)

E-mail: [info@moschip.ru](mailto:info@moschip.ru)

Skype отдела продаж:

moschip.ru

moschip.ru\_4

moschip.ru\_6

moschip.ru\_9