

ADTJA1101-RMII

TJA1101 Adapter Card

User Guide

September 2018



ADTJA1101-RMII – Getting started

Components in the box:

- Board: [ADTJA1101-RMII](#)
- Cable: 0.5m of jacketed Unshielded Twisted Pair (UTP), automotive grade



Get additional documentation for

- ADTJA1101-RMII
 - Gerber
 - Schematics / BoM
- TJA1101
 - Datasheet
 - Application Hints
 - Etc...

from NXP's document repository

→ www.docstore.nxp.com

- Register (NDA required) / Login
- Navigate:
 - Products → In-Vehicle Networking → Automotive Ethernet → ADTJA1101-RMII

SABRE Connector

- [SABRE = Smart Application Blueprint for Rapid Engineering](#)
- Accelerate your time to market with our premiere series of market-focused development systems based on application controllers: Smart Application Blueprint for Rapid Engineering (SABRE). SABRE platforms deliver the advanced technology features required for next-generation automotive systems.

ADTJA1101-RMII – Application

- The [ADTJA1101-RMII](#) is a daughter card carrying NXP's [TJA1101](#) 100BASE-T1 Ethernet PHY
- It adapts to micro controller development boards with SABRE connector, e.g. [S32K148EVB](#)
- The full TJA110x driver set is supported by the [S32K148EVB SDK](#).

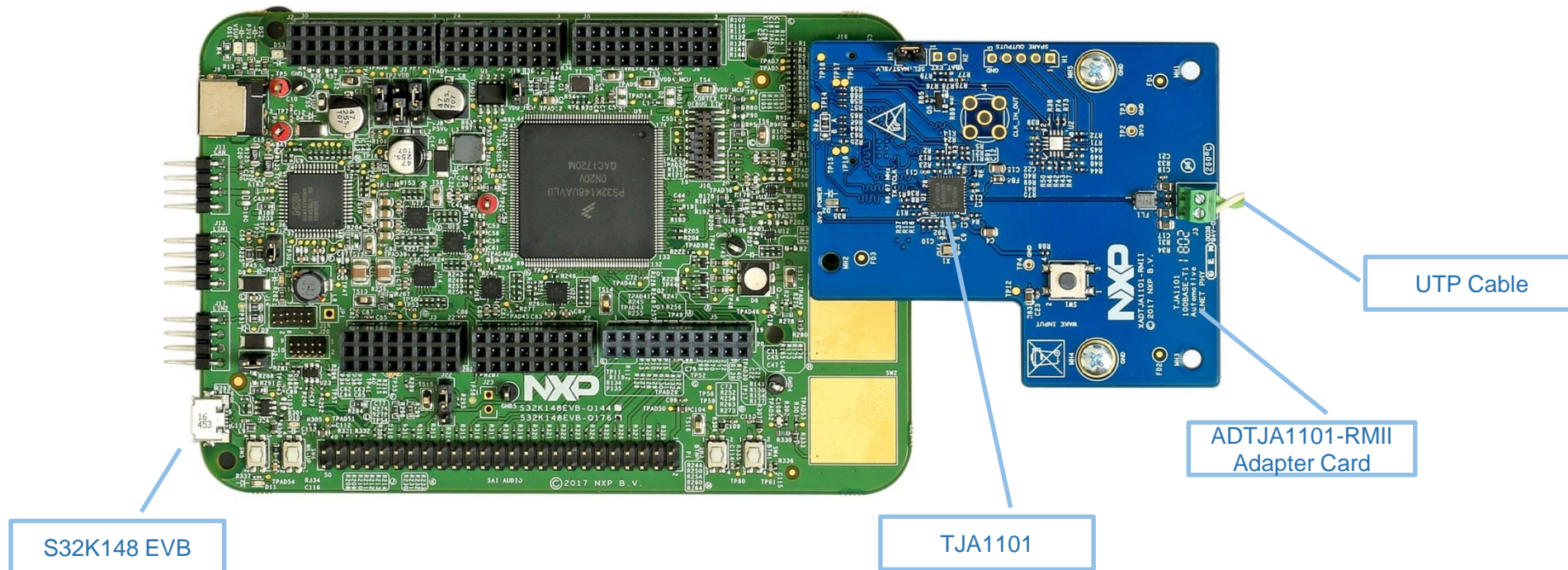

How to connect the SABRE enabled Boards

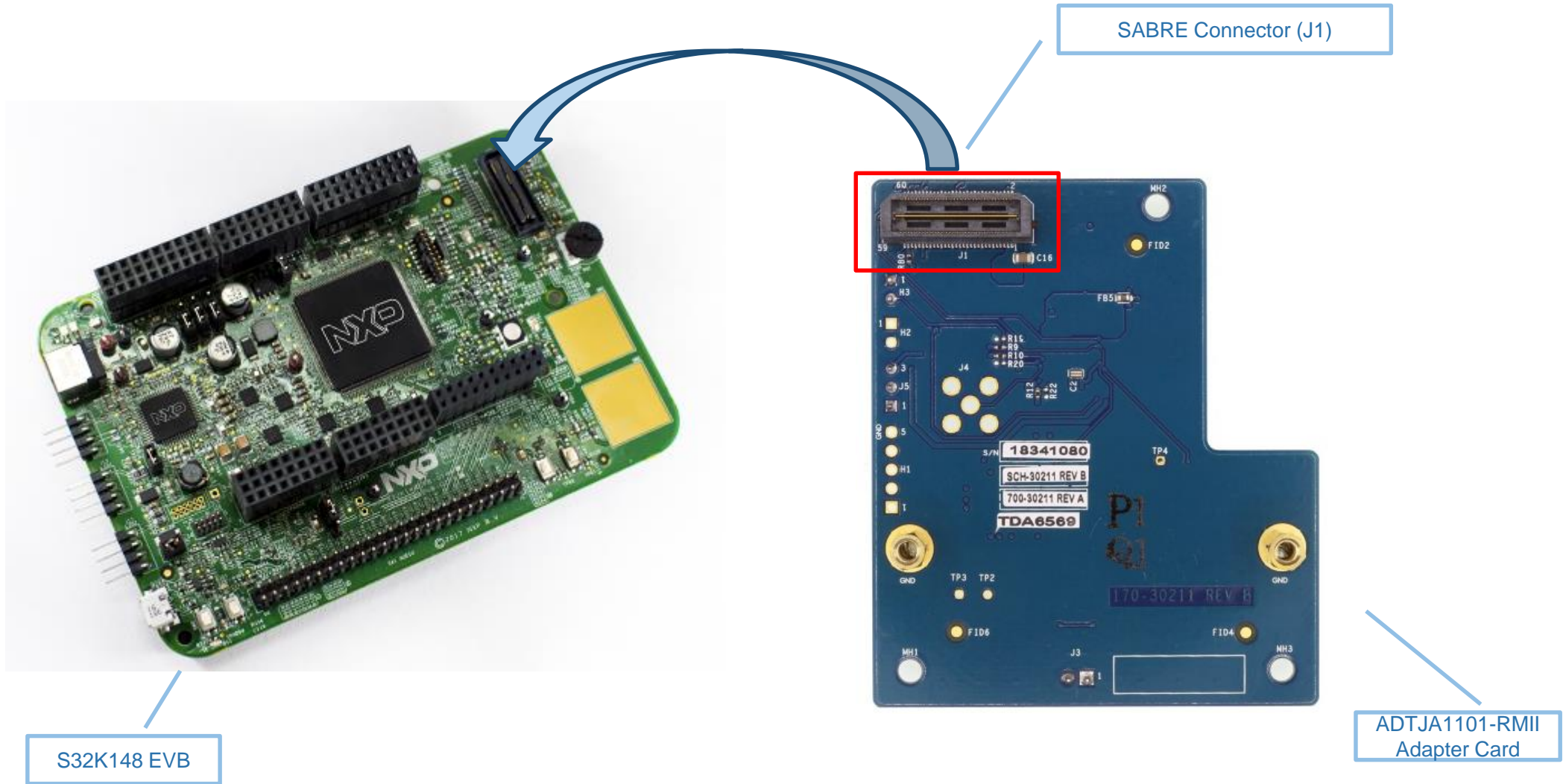

S32K148 EVB

SABRE Connector (J1)

ADTJA1101-RMII Adapter Card

ADTJA1101-RMII Power Up

Power input options:

- Power Input 12V
- USB / Open SDA

For Jumper Settings please refer to [S32K148EVB Quick Start Guide](#)

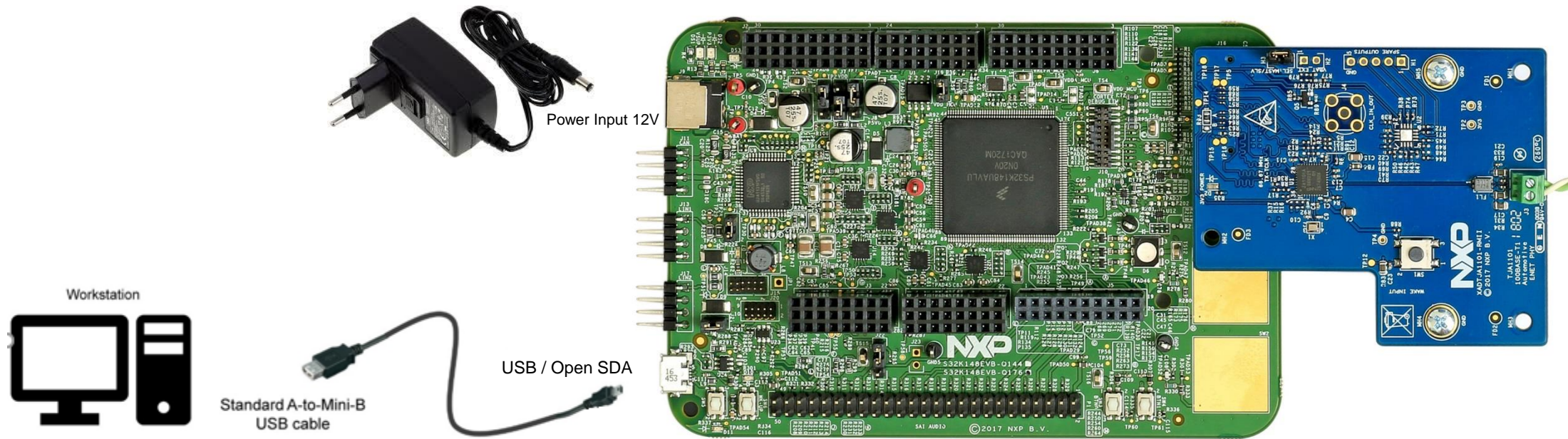

ADTJA1101-RMII Board Features

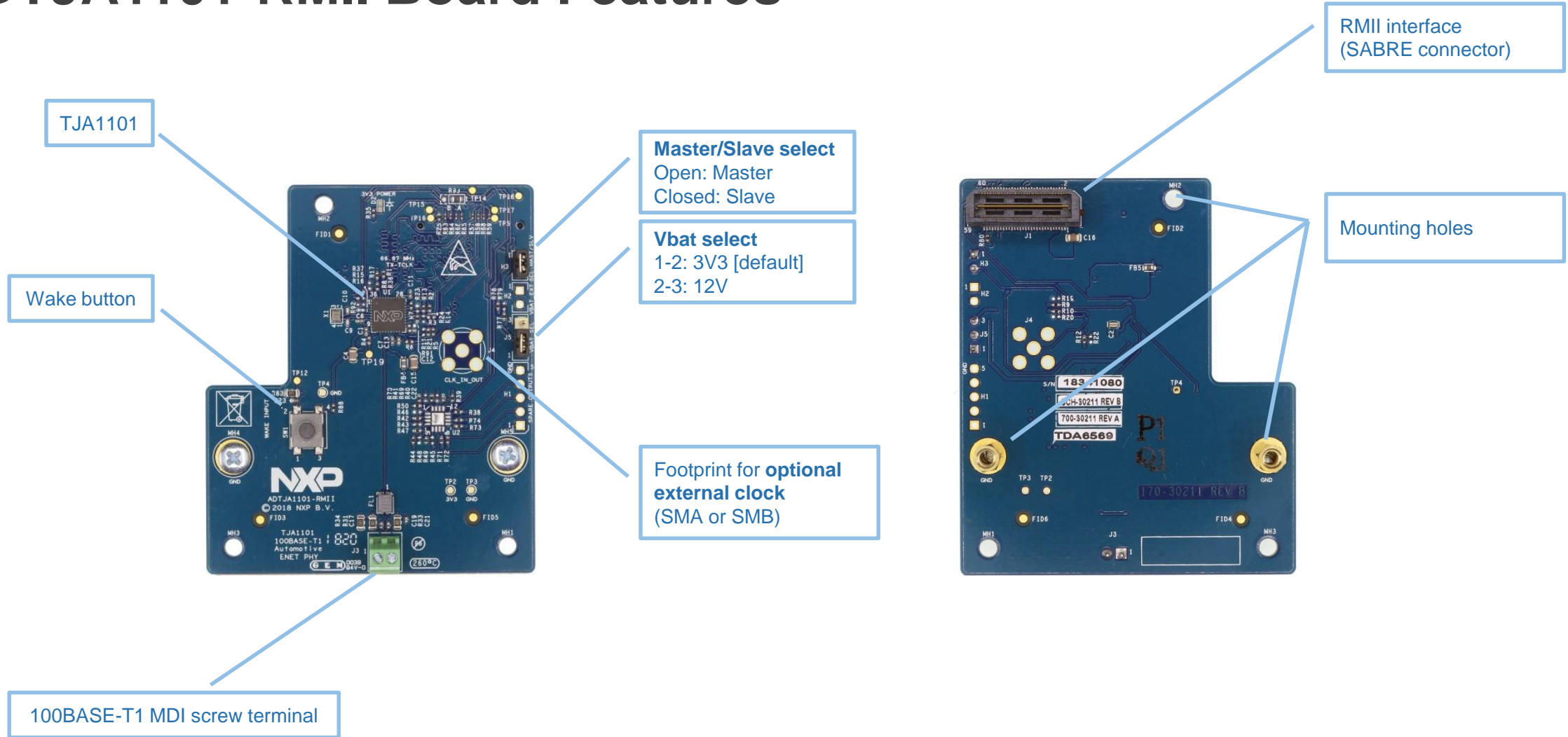

For configuration options of TJA1101 → please refer to [product data sheet](#)

ADTJA1101-RMII Block Diagram

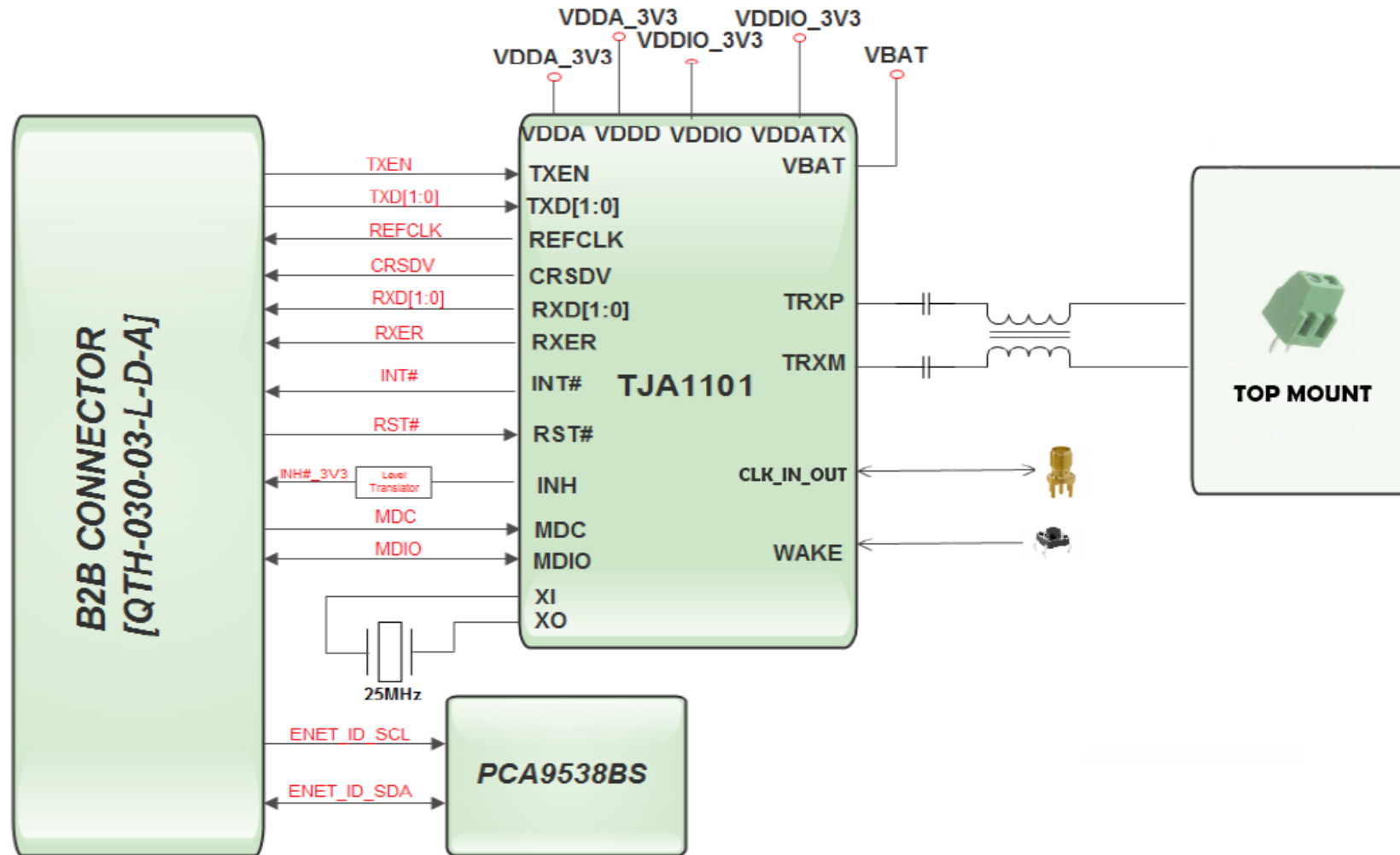

TJA110x driver pre-integration with S32K SDK

- Production grade driver support is pre-integrated with SDKs for NXP microcontrollers
- GUI configuration support in S32 Design Studio IDE
→ see screenshot
- Supports TJA1100, TJA1101 and TJA1102(S)
 - Support for generic PHY devices using IEEE registers
- Currently supported by:
 - S32K SDK v0.8.6
 - MPC574x SDK v0.9.0
 - i.MX8 SDK (planned)
- [Download](#) S32K SDK

GUI Driver Configuration

PHYs Shared components

PHYs list

| # | PHY | PHY Type | Address | PHY Location | PHY Role | ENET instance |
|---|-------------------------------------|----------|---------|--------------|-------------------|---------------|
| 0 | <input checked="" type="checkbox"/> | TJA110x | 1 | External | Master | 0 |
| 1 | <input checked="" type="checkbox"/> | TJA110x | 2 | External | Slave | 0 |
| 2 | <input checked="" type="checkbox"/> | TJA110x | 3 | External | Master | 0 |
| 3 | <input checked="" type="checkbox"/> | TJA110x | 4 | External | Master | 0 |
| 4 | <input checked="" type="checkbox"/> | Generic | 8 | External | Automatic conf... | 0 |

Details for selected row:

PHY 4

PHY Type: Generic

Address: 8

PHY Location: External

PHY Role: Automatic configuration, i.e. use the def...

ENET instance: 0

Link Up Event Callback:

Link Down Event Callback:

Auto-negotiation Complete Event Callback:

Linux Driver for TJA110X

- Single Linux driver for TJA110x
- Integrates into Linux' PHY Abstraction Layer (PAL)
- Extended with automotive features
 - Support for Managed and Autonomous Mode
 - Master/Slave configuration
 - Cable Test
 - LED, Loopback and Test Modes
 - Sleep and Wakeup
- Implements polling of interrupt status register
 - Warning about and reaction to failure conditions

→ Download [here](#)

→ FAQ [here](#)

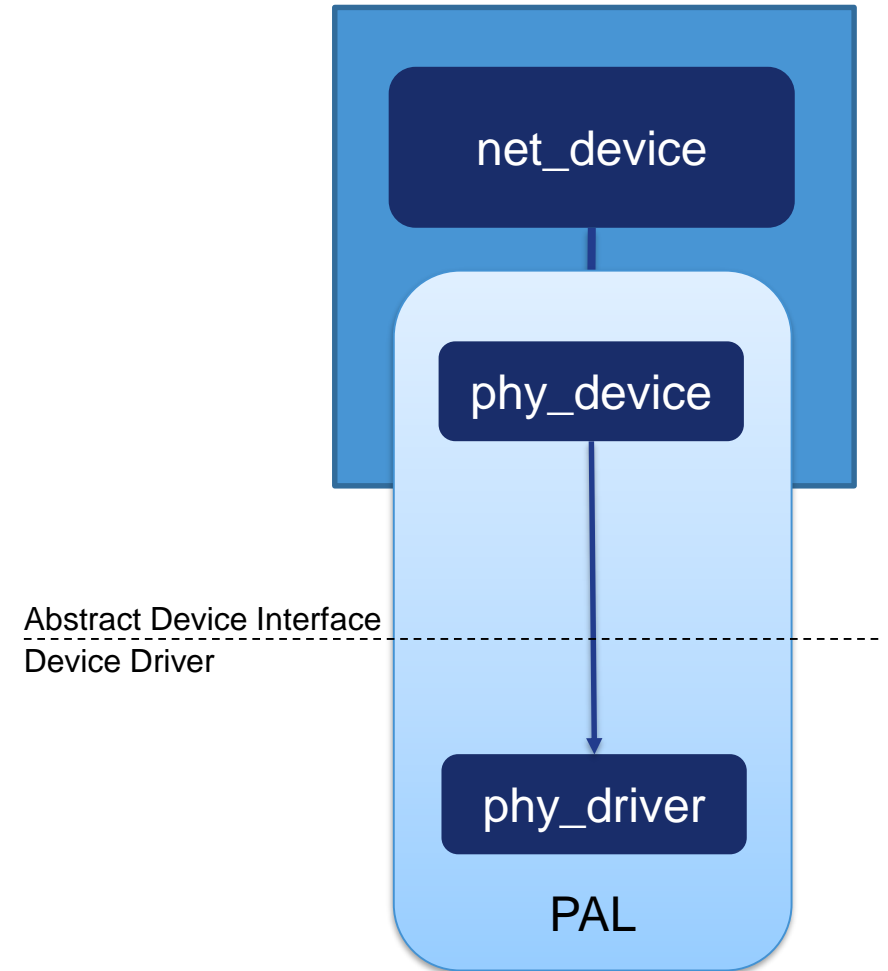

ADTJA1101-RMII Compatible Controller Boards

- [S32K148EVB: S32K148 Evaluation Board](#)
 - Low-cost evaluation platform and development system for quick application prototyping with the S32K148 MCU belonging to the S32K series of Ultra-Reliable Microcontrollers (MCUs).

- i.MX8 (board to be released soon)



NXP Link Partner Boards for 100BASE-T1 System Setup

- [SJA1105SMBEVM](#): Gateway Prototyping Platform
 - Enables early SW development for SJA1105P/Q/R/S Automotive Ethernet switch family and the TJA1102 Automotive Ethernet PHYs on a market-leading Automotive MPC5748xG MCU.
- [SJA1105Q-EVB](#): Ethernet Switch & PHY Evaluation Board
 - An evaluation system that supports the SJA1105P/Q/R/S Automotive Ethernet switch family in conjunction with the TJA1102HN Ethernet PHY Transceiver.
- [OM14500/TJA1101](#): 100BASE-T1 PHY Evaluation Board
 - Low-cost hardware development tool which supports the functional evaluation of the 100BASE-T1 PHY transceiver TJA1101.
- [FibreCode FC602 USB OABR Stick](#):
 - The FC602 USB OABR Stick functions as seamless media converter between a standard USB 2.0 interface and an automotive Ethernet network. On Windows and Linux host PCs the USB OABR Stick is detected as standard Ethernet device.



... ADTJA1101-RMII is generally interoperable to any other 100BASE-T1 link partner

ADTJA1101-RMII Connected System Examples

#1

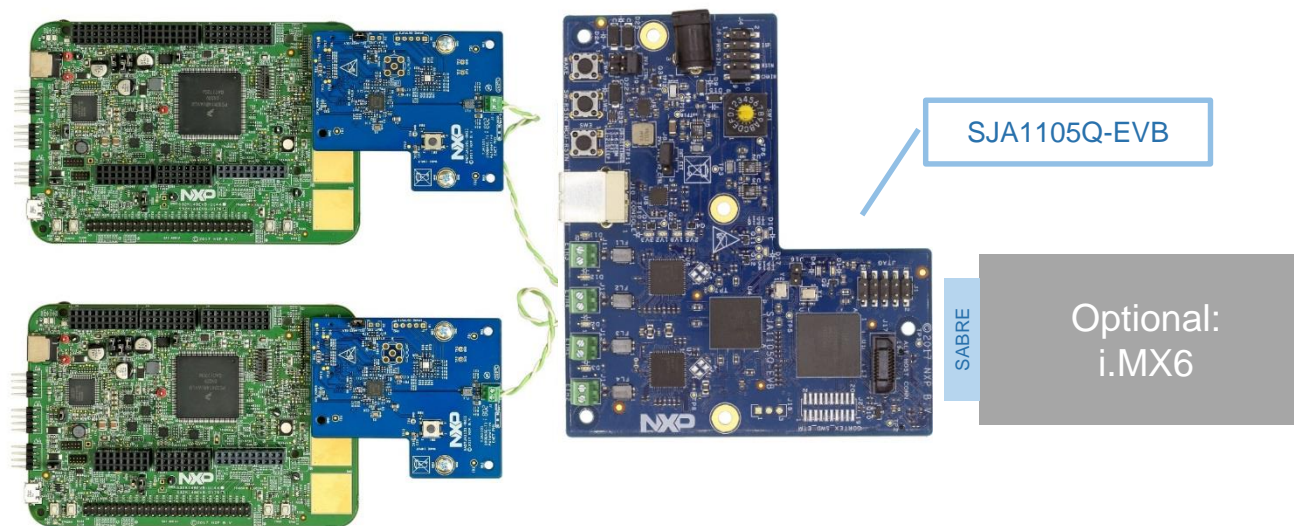

#2

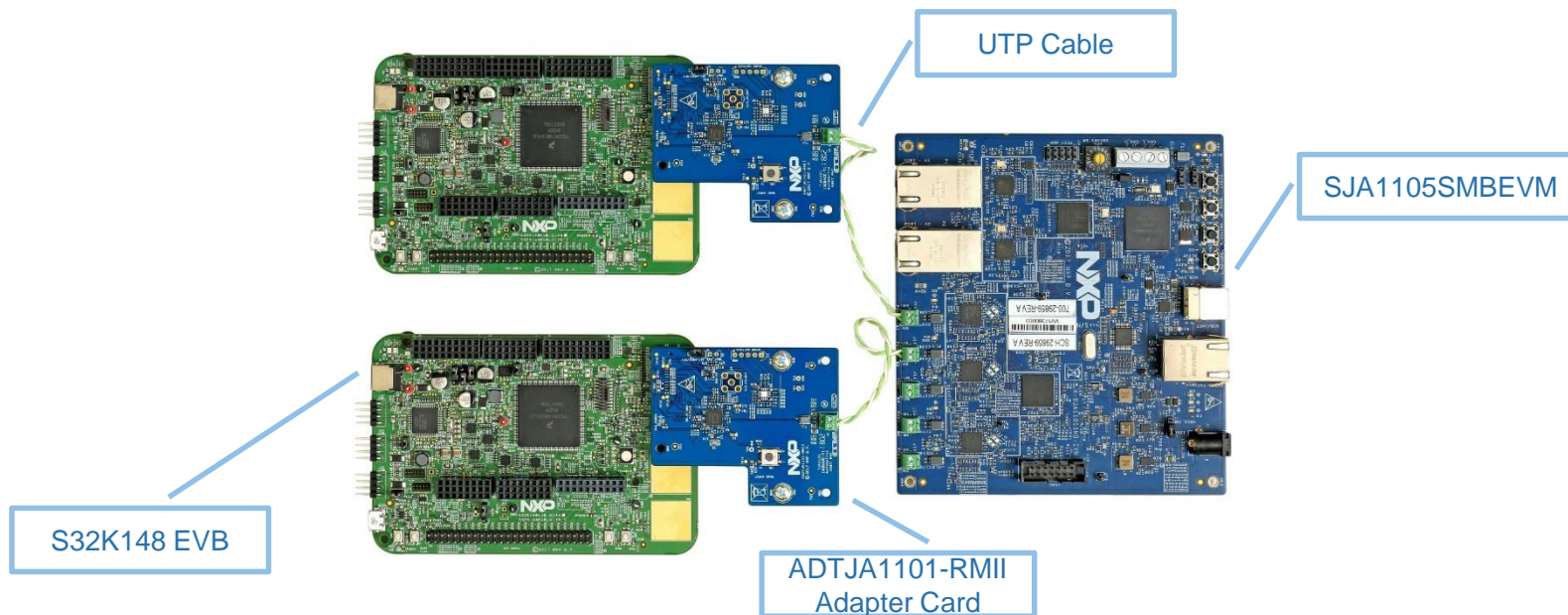

NXP

SECURE CONNECTIONS
FOR A SMARTER WORLD



Данный компонент на территории Российской Федерации

Вы можете приобрести в компании MosChip.

Для оперативного оформления запроса Вам необходимо перейти по данной ссылке:

<http://moschip.ru/get-element>

Вы можете разместить у нас заказ для любого Вашего проекта, будь то серийное производство или разработка единичного прибора.

В нашем ассортименте представлены ведущие мировые производители активных и пассивных электронных компонентов.

Нашей специализацией является поставка электронной компонентной базы двойного назначения, продукции таких производителей как XILINX, Intel (ex.ALTERA), Vicor, Microchip, Texas Instruments, Analog Devices, Mini-Circuits, Amphenol, Glenair.

Сотрудничество с глобальными дистрибьюторами электронных компонентов, предоставляет возможность заказывать и получать с международных складов практически любой перечень компонентов в оптимальные для Вас сроки.

На всех этапах разработки и производства наши партнеры могут получить квалифицированную поддержку опытных инженеров.

Система менеджмента качества компании отвечает требованиям в соответствии с ГОСТ Р ИСО 9001, ГОСТ РВ 0015-002 и ЭС РД 009

Офис по работе с юридическими лицами:

105318, г.Москва, ул.Щербаковская д.3, офис 1107, 1118, ДЦ «Щербаковский»

Телефон: +7 495 668-12-70 (многоканальный)

Факс: +7 495 668-12-70 (доб.304)

E-mail: info@moschip.ru

Skype отдела продаж:

moschip.ru

moschip.ru_4

moschip.ru_6

moschip.ru_9