



Micro Commercial Components



Micro Commercial Components  
20736 Marilla Street Chatsworth  
CA 91311

Phone: (818) 701-4933  
Fax: (818) 701-4939

# US2A THRU US2M

## Features

- Halogen free available upon request by adding suffix "-HF"
- Glass Passivated Chip
- Super Fast Switching For High Efficiency
- Low Forward Voltage Drop And High Current Capability
- Low Reverse Leakage Current
- Lead Free Finish/Rohs Compliant (Note1) ("P" Suffix designates Compliant. See ordering information)
- Epoxy meets UL 94 V-0 flammability rating
- Moisture Sensitivity Level 1

## Maximum Ratings

- Operating Temperature: -50°C to +150°C
- Storage Temperature: -50°C to +150°C
- Maximum Thermal Resistance; 20°C/W Junction To Lead

| MCC Catalog Number | Device Marking | Maximum Recurrent Peak Reverse Voltage | Maximum RMS Voltage | Maximum DC Blocking Voltage |
|--------------------|----------------|--|---------------------|-----------------------------|
| US2A               | US2A           | 50V                                    | 35V                 | 50V                         |
| US2B               | US2B           | 100V                                   | 70V                 | 100V                        |
| US2C               | US2C           | 150V                                   | 105V                | 150V                        |
| US2D               | US2D           | 200V                                   | 140V                | 200V                        |
| US2G               | US2G           | 400V                                   | 280V                | 400V                        |
| US2J               | US2J           | 600V                                   | 420V                | 600V                        |
| US2K               | US2K           | 800V                                   | 560V                | 800V                        |
| US2M               | US2M           | 1000V                                  | 700V                | 1000V                       |

## Electrical Characteristics @ 25°C Unless Otherwise Specified

|   |             |   |  |
|---|-------------|---|--|
| Average Forward Current                                 | $I_{F(AV)}$ | 2.0A  | $T_L = 110^\circ\text{C}$                                    |
| Peak Forward Surge Current                              | $I_{FSM}$   | 50A   | 8.3ms, half sine   |
| Maximum Instantaneous Forward Voltage                   | $V_F$       | 1.0V<br>1.4V<br>1.65V   | $I_{FM} = 2.0\text{A};$<br>$T_J = 25^\circ\text{C}$          |
| Maximum DC Reverse Current At Rated DC Blocking Voltage | $I_R$       | 5 $\mu\text{A}$<br>200 $\mu\text{A}$ (Max)<br>16 $\mu\text{A}$ (Typ.) | $T_J = 25^\circ\text{C}$<br>$T_J = 125^\circ\text{C}$        |
| Maximum Reverse Recovery Time                           | $T_{rr}$    | 50ns<br>75ns  | $I_F=0.5\text{A}, I_R=1.0\text{A},$<br>$I_{rr}=0.25\text{A}$ |
| Typical Junction Capacitance                            | $C_J$       | 28pF  | Measured at 1.0MHz, $V_R=4.0\text{V}$                        |

\*Pulse test: Pulse width 300  $\mu\text{sec}$ , Duty cycle 1%

Note:1. High Temperature Solder Exemptions Applied, see EU Directive Annex 7a.

## 2 Amp Ultra Fast Rectifier 50 to 1000 Volts

### DO-214AA (SMB) (Lead Frame)

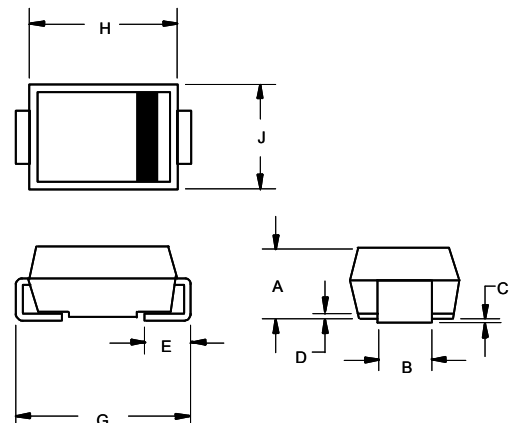

| DIM | DIMENSIONS |          |          |          | NOTE |
|-----|------------|----------|----------|----------|------|
|     | INCHES     |          | MM       |          |      |
| A   | MIN .075   | MAX .095 | MIN 1.91 | MAX 2.41 |      |
| B   | .077       | .083     | 1.96     | 2.10     |      |
| C   | .002       | .008     | .05      | .20      |      |
| D   | ---        | .02      | ---      | .51      |      |
| E   | .030       | .060     | .76      | 1.52     |      |
| G   | .200       | .220     | 5.08     | 5.59     |      |
| H   | .160       | .187     | 4.06     | 4.75     |      |
| J   | .130       | .155     | 3.30     | 3.94     |      |

### SUGGESTED SOLDER PAD LAYOUT

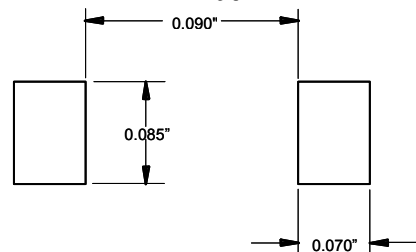

# US2A thru US2M

Figure 1  
Typical Forward Characteristics

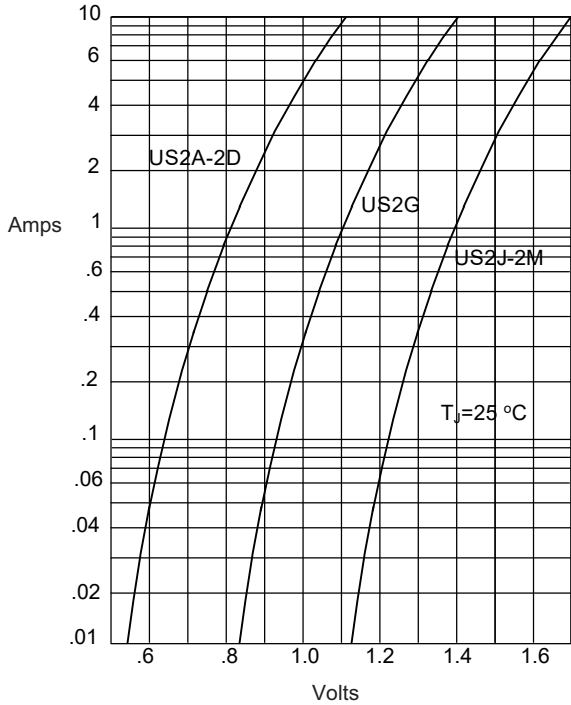

Instantaneous Forward Current - Amperes versus  
Instantaneous Forward Voltage - Volts

Figure 2  
Forward Derating Curve

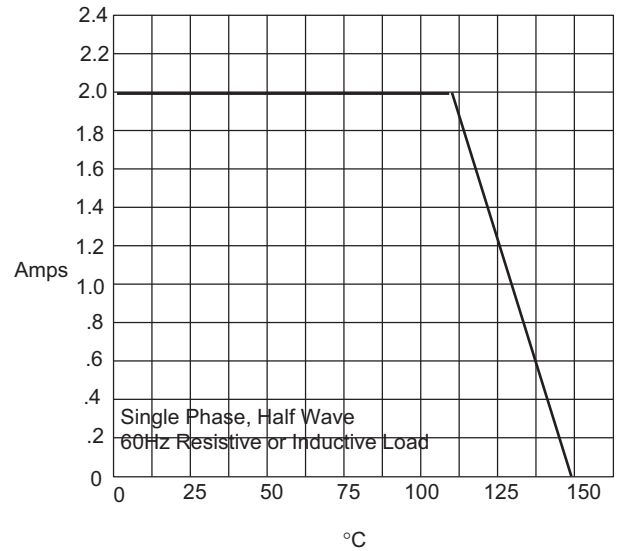

Average Forward Rectified Current - Amperes versus  
Lead Temperature -  $^\circ\text{C}$

Figure 3  
Junction Capacitance

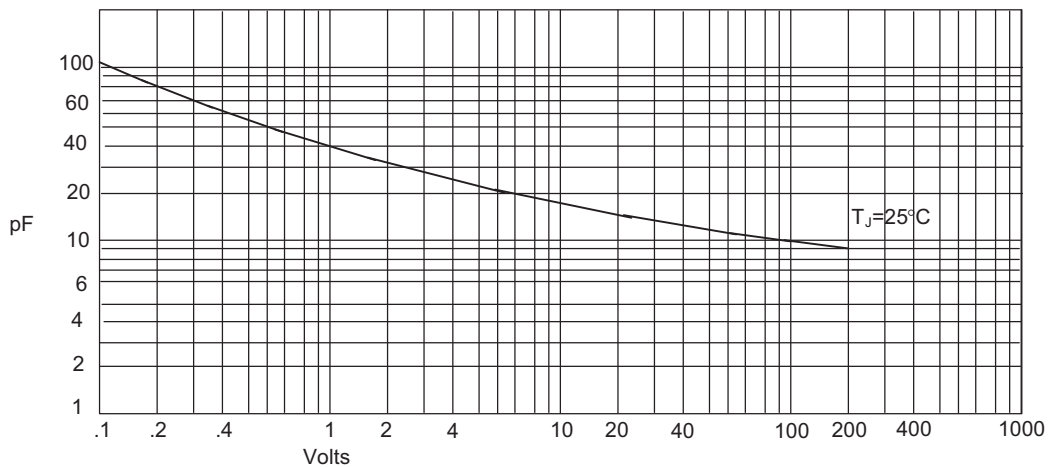

Junction Capacitance - pF versus  
Reverse Voltage - Volts

# US2A thru US2M

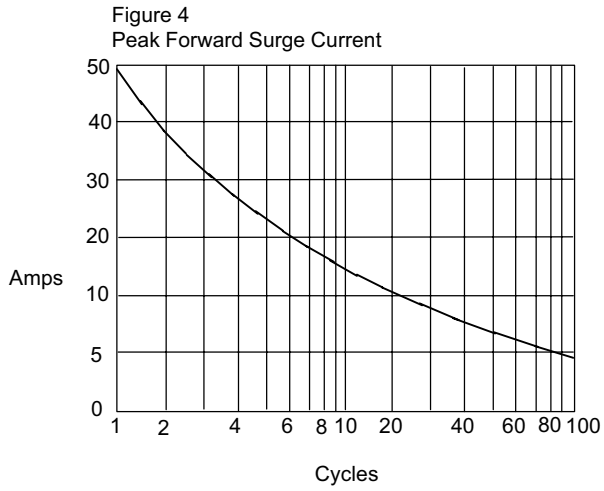

Peak Forward Surge Current - Amperes versus  
Number Of Cycles At 60Hz - Cycles

Figure 5  
Reverse Recovery Time Characteristic And Test Circuit Diagram

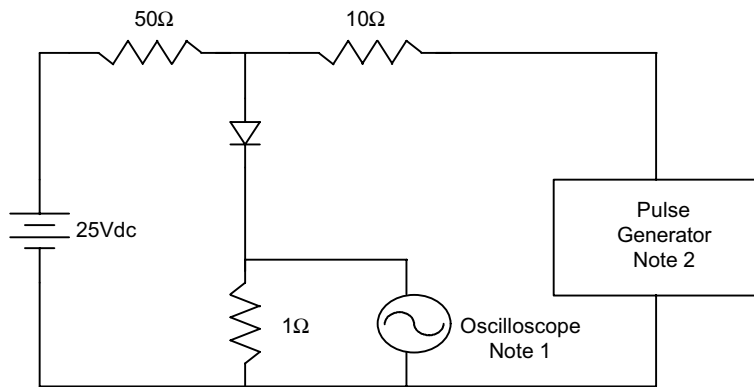

- Notes:
1. Rise Time = 7ns max.  
Input impedance = 1 megohm, 22pF
  2. Rise Time = 10ns max.  
Source impedance = 50 ohms
  3. Resistors are non-inductive

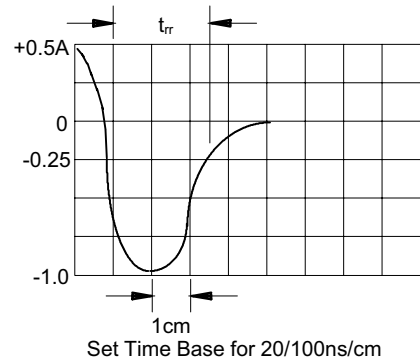



Micro Commercial Components

### Ordering Information :

| Device         | Packing               |
|----------------|-----------------------|
| Part Number-TP | Tape&Reel: 3Kpcs/Reel |

Note : Adding "-HF" suffix for halogen free, eg. Part Number-TP-HF

#### \*\*\*IMPORTANT NOTICE\*\*\*

**Micro Commercial Components Corp.** reserves the right to make changes without further notice to any product herein to make corrections, modifications , enhancements , improvements , or other changes . **Micro Commercial Components Corp .** does not assume any liability arising out of the application or use of any product described herein; neither does it convey any license under its patent rights ,nor the rights of others . The user of products in such applications shall assume all risks of such use and will agree to hold **Micro Commercial Components Corp .** and all the companies whose products are represented on our website, harmless against all damages.

#### \*\*\*LIFE SUPPORT\*\*\*

MCC's products are not authorized for use as critical components in life support devices or systems without the express written approval of Micro Commercial Components Corporation.

#### \*\*\*CUSTOMER AWARENESS\*\*\*

Counterfeiting of semiconductor parts is a growing problem in the industry. Micro Commercial Components (MCC) is taking strong measures to protect ourselves and our customers from the proliferation of counterfeit parts. MCC strongly encourages customers to purchase MCC parts either directly from MCC or from Authorized MCC Distributors who are listed by country on our web page cited below. Products customers buy either from MCC directly or from Authorized MCC Distributors are genuine parts, have full traceability, meet MCC's quality standards for handling and storage. **MCC will not provide any warranty coverage or other assistance for parts bought from Unauthorized Sources.** MCC is committed to combat this global problem and encourage our customers to do their part in stopping this practice by buying direct or from authorized distributors.

## Данный компонент на территории Российской Федерации

### Вы можете приобрести в компании MosChip.

Для оперативного оформления запроса Вам необходимо перейти по данной ссылке:

<http://moschip.ru/get-element>

Вы можете разместить у нас заказ для любого Вашего проекта, будь то серийное производство или разработка единичного прибора.

В нашем ассортименте представлены ведущие мировые производители активных и пассивных электронных компонентов.

Нашей специализацией является поставка электронной компонентной базы двойного назначения, продукции таких производителей как XILINX, Intel (ex.ALTERA), Vicor, Microchip, Texas Instruments, Analog Devices, Mini-Circuits, Amphenol, Glenair.

Сотрудничество с глобальными дистрибьюторами электронных компонентов, предоставляет возможность заказывать и получать с международных складов практически любой перечень компонентов в оптимальные для Вас сроки.

На всех этапах разработки и производства наши партнеры могут получить квалифицированную поддержку опытных инженеров.

Система менеджмента качества компании отвечает требованиям в соответствии с ГОСТ Р ИСО 9001, ГОСТ РВ 0015-002 и ЭС РД 009

### Офис по работе с юридическими лицами:

105318, г.Москва, ул.Щербаковская д.3, офис 1107, 1118, ДЦ «Щербаковский»

Телефон: +7 495 668-12-70 (многоканальный)

Факс: +7 495 668-12-70 (доб.304)

E-mail: [info@moschip.ru](mailto:info@moschip.ru)

Skype отдела продаж:

moschip.ru

moschip.ru\_4

moschip.ru\_6

moschip.ru\_9