

## FEATURES

1.8 V to 5.5 V single supply  
 $\pm 2.5$  V dual supply  
 3  $\Omega$  on resistance  
 0.75  $\Omega$  on resistance flatness  
 100 pA leakage currents  
 14 ns switching times  
 Single 8-to-1 multiplexer ADG708  
 Differential 4-to-1 multiplexer ADG709  
 16-lead TSSOP package  
 Low power consumption  
 TTL-/CMOS-compatible inputs  
 Qualified for automotive applications

## APPLICATIONS

Data acquisition systems  
 Communication systems  
 Relay replacement  
 Audio and video switching  
 Battery-powered systems

## GENERAL DESCRIPTION

The ADG708/ADG709 are low voltage, CMOS analog multiplexers comprising eight single channels and four differential channels, respectively. The ADG708 switches one of eight inputs (S1 to S8) to a common output, D, as determined by the 3-bit binary address lines A0, A1, and A2. The ADG709 switches one of four differential inputs to a common differential output as determined by the 2-bit binary address lines A0 and A1. An EN input on both devices is used to enable or disable the device. When disabled, all channels are switched off.

Low power consumption and an operating supply range of 1.8 V to 5.5 V make the ADG708/ADG709 ideal for battery-powered, portable instruments. All channels exhibit break-before-make switching action preventing momentary shorting when switching channels.

These switches are designed on an enhanced submicron process that provides low power dissipation yet gives high switching speed, very low on resistance, and leakage currents.

On resistance is in the region of a few ohms and is closely matched between switches and very flat over the full signal range. These parts can operate equally well as either multiplexers or demultiplexers and have an input signal range that extends to the supplies.

The ADG708/ADG709 are available in a 16-lead TSSOP.

### Rev. D

### Document Feedback

Information furnished by Analog Devices is believed to be accurate and reliable. However, no responsibility is assumed by Analog Devices for its use, nor for any infringements of patents or other rights of third parties that may result from its use. Specifications subject to change without notice. No license is granted by implication or otherwise under any patent or patent rights of Analog Devices. Trademarks and registered trademarks are the property of their respective owners.

## FUNCTIONAL BLOCK DIAGRAMS

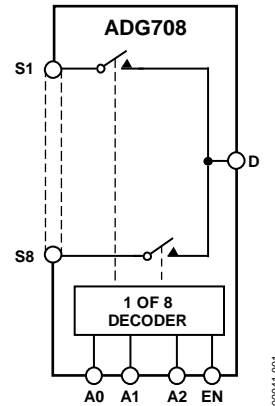

Figure 1.

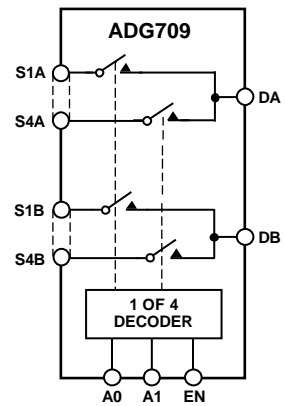

Figure 2.

## PRODUCT HIGHLIGHTS

1. Single-/dual-supply operation. The ADG708/ADG709 are fully specified and guaranteed with 3 V and 5 V single-supply and  $\pm 2.5$  V dual-supply rails.
2. Low  $R_{ON}$  (3  $\Omega$  typical).
3. Low power consumption (<0.01  $\mu$ W).
4. Guaranteed break-before-make switching action.
5. Small 16-lead TSSOP package.

**TABLE OF CONTENTS**

|   |    |  |    |
|---|----|--|----|
| Features .....                                    | 1  | Truth Tables.....                        | 11 |
| Applications.....                                 | 1  | Typical Performance Characteristics..... | 12 |
| General Description .....                         | 1  | Test Circuits.....                       | 15 |
| Functional Block Diagrams .....                   | 1  | Terminology.....                         | 18 |
| Product Highlights .....                          | 1  | Applications Information.....            | 19 |
| Revision History.....                             | 2  | Power Supply Sequencing.....             | 19 |
| Specifications.....                               | 3  | Outline Dimensions .....                 | 20 |
| Dual Supply .....                                 | 7  | Ordering Guide .....                     | 20 |
| Absolute Maximum Ratings .....                    | 9  | Automotive Products.....                 | 20 |
| ESD Caution.....                                  | 9  |  |    |
| Pin Configurations and Function Descriptions..... | 10 |  |    |

**REVISION HISTORY**

**1/13–Rev. C to Rev. D**

|                                |    |
|--------------------------------|----|
| Changes to Ordering Guide..... | 20 |
|--------------------------------|----|

**4/09–Rev. B to Rev. C**

|  |    |
|--|----|
| Changes to Table 1.....                          | 3  |
| Changes to Table 2.....                          | 5  |
| Changes to Table 3.....                          | 7  |
| Moved Truth Tables Section .....                 | 11 |
| Changes to Figure 7, Figure 8, and Figure 9..... | 12 |
| Changes to Figure 13 and Figure 14.....          | 13 |
| Moved Terminology Section.....                   | 18 |
| Changes to Ordering Guide.....                   | 20 |

**8/06–Rev. A to Rev. B**

|  |           |
|--|-----------|
| Updated Format .....                             | Universal |
| Changes to Absolute Maximum Ratings Section..... | 9         |
| Added Table 7 and Table 8.....                   | 10        |
| Updated Outline Dimensions.....                  | 18        |
| Changes to Ordering Guide.....                   | 18        |

**4/02—Rev. 0 to Rev. A**

|   |     |
|---|-----|
| Edits to Features and Product Highlights..... | 1   |
| Change to Specifications .....                | 2–4 |
| Edits to Absolute Maximum Ratings Notes.....  | 5   |
| Edits to TPCs 2, 5, 6–9, 11, and 15 .....     | 7–9 |
| Edits to Test Circuits 9 and 10.....          | 11  |
| Addition of Test Circuit 11 .....             | 11  |

**10/00—Revision 0: Initial Version**

## SPECIFICATIONS

$V_{DD} = 5\text{ V} \pm 10\%$ ,  $V_{SS} = 0\text{ V}$ ,  $GND = 0\text{ V}$ , unless otherwise noted.

Table 1.

| Parameter   | B Version  |                    |                    | C Version               |                   |                    | Unit                                   | Test Conditions/<br>Comments   |
|---|------------|--------------------|--------------------|-------------------------|-------------------|--------------------|--|--|
|   | +25°C      | -40°C to<br>+85°C  | -40°C to<br>+125°C | +25°C                   | -40°C to<br>+85°C | -40°C to<br>+125°C |  |  |
| ANALOG SWITCH   |            |                    |                    |                         |                   |                    |  |  |
| Analog Signal Range   |            | 0 V to<br>$V_{DD}$ | 0 V to<br>$V_{DD}$ |                         |                   | 0 V to<br>$V_{DD}$ | V                                      |  |
| On Resistance ( $R_{ON}$ )                                  | 3          |                    |                    | 3                       |                   |                    | $\Omega$ typ                           | $V_S = 0\text{ V to } V_{DD}$ , $I_{DS} = 10\text{ mA}$ ;<br>see Figure 20   |
| On Resistance Match<br>Between Channels ( $\Delta R_{ON}$ ) | 4.5<br>0.4 | 5<br>7             | 7                  | 4.5<br>0.4              | 5<br>7            | 7                  | $\Omega$ max<br>$\Omega$ typ           |  |
| On Resistance Flatness<br>( $R_{FLAT(ON)}$ )                | 0.75       | 0.8                | 1.5                | 0.75                    | 0.8               | 1.5                | $\Omega$ max<br>$\Omega$ typ           | $V_S = 0\text{ V to } V_{DD}$ , $I_{DS} = 10\text{ mA}$<br>$V_S = 0\text{ V to } V_{DD}$ , $I_{DS} = 10\text{ mA}$                                 |
|   |            | 1.2                | 1.65               |                         | 1.2               | 1.65               | $\Omega$ max                           |  |
| LEAKAGE CURRENTS  |            |                    |                    |                         |                   |                    |  |  |
| Source Off Leakage, $I_S$ (Off)                             | $\pm 0.01$ |                    |                    | $\pm 0.01$              |                   |                    | nA typ                                 | $V_{DD} = 5.5\text{ V}$<br>$V_D = 4.5\text{ V}/1\text{ V}$ , $V_S = 1\text{ V}/4.5\text{ V}$ ;<br>see Figure 21                                    |
| Drain Off Leakage, $I_D$ (Off)                              | $\pm 0.01$ | $\pm 20$           | $\pm 20$           | $\pm 0.1$<br>$\pm 0.01$ | $\pm 0.3$         | $\pm 1$            | nA max<br>nA typ                       | $V_D = 4.5\text{ V}/1\text{ V}$ , $V_S = 1\text{ V}/4.5\text{ V}$ ;<br>see Figure 22   |
| Channel On Leakage, $I_D$ , $I_S$ (On)                      | $\pm 0.01$ | $\pm 20$           | $\pm 20$           | $\pm 0.1$<br>$\pm 0.01$ | $\pm 0.75$        | $\pm 6$            | nA max<br>nA typ                       | $V_D = V_S = 1\text{ V or } 4.5\text{ V}$ ;<br>see Figure 23   |
|   |            | $\pm 20$           | $\pm 20$           | $\pm 0.1$               | $\pm 0.75$        | $\pm 6$            | nA max                                 |  |
| DIGITAL INPUTS  |            |                    |                    |                         |                   |                    |  |  |
| Input High Voltage, $V_{INH}$                               |            |                    | 2.4                |                         |                   | 2.4                | V min                                  |  |
| Input Low Voltage, $V_{INL}$                                |            |                    | 0.8                |                         |                   | 0.8                | V max                                  |  |
| Input Current<br>$I_{INL}$ or $I_{INH}$                     | 0.005      |                    | $\pm 0.1$          | 0.005                   |                   | $\pm 0.1$          | $\mu\text{A}$ typ<br>$\mu\text{A}$ max | $V_{IN} = V_{INL}$ or $V_{INH}$  |
| Digital Input Capacitance, $C_{IN}$                         | 2          |                    |                    | 2                       |                   |                    | pF typ                                 |  |
| DYNAMIC CHARACTERISTICS <sup>1</sup>                        |            |                    |                    |                         |                   |                    |  |  |
| $t_{TRANSITION}$  | 14         |                    |                    | 14                      |                   |                    | ns typ                                 | $R_L = 300\ \Omega$ , $C_L = 35\text{ pF}$ ;<br>see Figure 24  |
| Break-Before-Make Time<br>Delay, $t_{OPEN}$                 | 8          | 25                 | 25                 | 8                       | 25                | 25                 | ns max<br>ns typ                       | $V_{S1} = 3\text{ V}/0\text{ V}$ , $V_{S8} = 0\text{ V}/3\text{ V}$<br>$R_L = 300\ \Omega$ , $C_L = 35\text{ pF}$                                  |
| $t_{ON}$ (EN)   | 14         | 1                  | 1                  | 14                      | 1                 | 1                  | ns min<br>ns typ                       | $V_S = 3\text{ V}$ ; see Figure 25<br>$R_L = 300\ \Omega$ , $C_L = 35\text{ pF}$   |
| $t_{OFF}$ (EN)  | 7          | 25                 | 25                 | 7                       | 25                | 25                 | ns max<br>ns typ                       | $V_S = 3\text{ V}$ ; see Figure 26<br>$R_L = 300\ \Omega$ , $C_L = 35\text{ pF}$   |
| Charge Injection  | $\pm 3$    | 12                 | 12                 | $\pm 3$                 | 12                | 12                 | ns max<br>pC typ                       | $V_S = 3\text{ V}$ ; see Figure 26<br>$V_S = 2.5\text{ V}$ , $R_S = 0\ \Omega$ ,<br>$C_L = 1\text{ nF}$ ; See Figure 27                            |
| Off Isolation   | -60<br>-80 |                    |                    | -60<br>-80              |                   |                    | dB typ<br>dB typ                       | $R_L = 50\ \Omega$ , $C_L = 5\text{ pF}$ , $f = 10\text{ MHz}$<br>$R_L = 50\ \Omega$ , $C_L = 5\text{ pF}$ ,<br>$f = 1\text{ MHz}$ ; see Figure 28 |

| Parameter                    | B Version |                   |                    | C Version |                   |                    | Unit              | Test Conditions/<br>Comments  |
|------------------------------|-----------|-------------------|--------------------|-----------|-------------------|--------------------|-------------------|---|
|                              | +25°C     | -40°C to<br>+85°C | -40°C to<br>+125°C | +25°C     | -40°C to<br>+85°C | -40°C to<br>+125°C |                   |   |
| Channel-to-Channel Crosstalk | -60       |                   |                    | -60       |                   |                    | dB typ            | $R_L = 50 \Omega$ , $C_L = 5 \text{ pF}$ ,<br>$f = 10 \text{ MHz}$                |
|                              | -80       |                   |                    | -80       |                   |                    | dB typ            | $R_L = 50 \Omega$ , $C_L = 5 \text{ pF}$ , $f = 1 \text{ MHz}$ ;<br>see Figure 29 |
| -3 dB Bandwidth              | 55        |                   |                    | 55        |                   |                    | MHz typ           | $R_L = 50 \Omega$ , $C_L = 5 \text{ pF}$ ;<br>see Figure 30                       |
| $C_S$ (Off)                  | 13        |                   |                    | 13        |                   |                    | pF typ            | $f = 1 \text{ MHz}$   |
| $C_D$ (Off)                  |           |                   |                    |           |                   |                    |                   |   |
| ADG708                       | 85        |                   |                    | 85        |                   |                    | pF typ            | $f = 1 \text{ MHz}$   |
| ADG709                       | 42        |                   |                    | 42        |                   |                    | pF typ            | $f = 1 \text{ MHz}$   |
| $C_D$ , $C_S$ (On)           |           |                   |                    |           |                   |                    |                   |   |
| ADG708                       | 96        |                   |                    | 96        |                   |                    | pF typ            | $f = 1 \text{ MHz}$   |
| ADG709                       | 48        |                   |                    | 48        |                   |                    | pF typ            | $f = 1 \text{ MHz}$   |
| POWER REQUIREMENTS           |           |                   |                    |           |                   |                    |                   | $V_{DD} = 5.5 \text{ V}$  |
| $I_{DD}$                     | 0.001     |                   |                    | 0.001     |                   |                    | $\mu\text{A typ}$ | Digital inputs = 0 V or 5.5 V   |
|                              |           | 1.0               | 1.0                |           | 1.0               | 1.0                | $\mu\text{A max}$ |   |

<sup>1</sup> Guaranteed by design, not subject to production test.

$V_{DD} = 3\text{ V} \pm 10\%$ ,  $V_{SS} = 0\text{ V}$ ,  $GND = 0\text{ V}$ , unless otherwise noted.

Table 2.

| Parameter   | B Version  |                   |                    | C Version  |                   |                    | Unit                                   | Test Conditions/<br>Comments  |
|---|------------|-------------------|--------------------|------------|-------------------|--------------------|--|---|
|   | +25°C      | -40°C to<br>+85°C | -40°C to<br>+125°C | +25°C      | -40°C to<br>+85°C | -40°C to<br>+125°C |  |   |
| ANALOG SWITCH   |            |                   |                    |            |                   |                    |  |   |
| Analog Signal Range   |            |                   | 0 V to<br>$V_{DD}$ |            |                   | 0 V to<br>$V_{DD}$ | V                                      |   |
| On Resistance ( $R_{ON}$ )                                  | 8          |                   |                    | 8          |                   |                    | $\Omega$ typ                           | $V_S = 0\text{ V to } V_{DD}$ , $I_{DS} = 10\text{ mA}$ ;<br>see Figure 20  |
| On Resistance Match Between<br>Channels ( $\Delta R_{ON}$ ) | 11         | 12                | 14                 | 11         | 12                | 14                 | $\Omega$ max                           | $V_S = 0\text{ V to } V_{DD}$ ,<br>$I_{DS} = 10\text{ mA}$  |
|   | 0.4        |                   |                    | 0.4        |                   |                    | $\Omega$ typ                           |   |
|   |            | 1.2               | 2                  |            | 1.2               | 2                  | $\Omega$ max                           |   |
| LEAKAGE CURRENTS  |            |                   |                    |            |                   |                    |  |   |
| Source Off Leakage, $I_S$ (Off)                             | $\pm 0.01$ |                   |                    | $\pm 0.01$ |                   |                    | nA typ                                 | $V_{DD} = 3.3\text{ V}$<br>$V_S = 3\text{ V}/1\text{ V}$ , $V_D = 1\text{ V}/3\text{ V}$ ;<br>see Figure 21       |
| Drain Off Leakage, $I_D$ (Off)                              | $\pm 0.01$ | $\pm 20$          | $\pm 20$           | $\pm 0.1$  | $\pm 0.3$         | $\pm 1$            | nA max<br>nA typ                       | $V_S = 3\text{ V}/1\text{ V}$ , $V_D = 1\text{ V}/3\text{ V}$ ;<br>see Figure 22                                  |
|   |            | $\pm 20$          | $\pm 20$           | $\pm 0.1$  | $\pm 0.75$        | $\pm 6$            | nA max<br>nA typ                       |   |
| Channel On Leakage, $I_D, I_S$ (On)                         | $\pm 0.01$ |                   |                    | $\pm 0.01$ |                   |                    | nA max<br>nA typ                       | $V_S = V_D = 1\text{ V or } 3\text{ V}$ ;<br>see Figure 23  |
|   |            | $\pm 20$          | $\pm 20$           | $\pm 0.1$  | $\pm 0.75$        | $\pm 6$            | nA max                                 |   |
| DIGITAL INPUTS  |            |                   |                    |            |                   |                    |  |   |
| Input High Voltage, $V_{INH}$                               |            |                   | 2.0                |            |                   | 2.0                | V min                                  | $V_{IN} = V_{INL}$ or $V_{INH}$   |
| Input Low Voltage, $V_{INL}$                                |            |                   | 0.8                |            |                   | 0.8                | V max                                  |   |
| Input Current<br>$I_{INL}$ or $I_{INH}$                     | 0.005      |                   |                    | 0.005      |                   |                    | $\mu\text{A}$ typ<br>$\mu\text{A}$ max |   |
|   |            |                   | $\pm 0.1$          |            |                   | $\pm 0.1$          | pF typ                                 |   |
| Digital Input Capacitance, $C_{IN}$                         | 2          |                   |                    | 2          |                   |                    | pF typ                                 |   |
| DYNAMIC CHARACTERISTICS <sup>1</sup>                        |            |                   |                    |            |                   |                    |  |   |
| $t_{TRANSITION}$  | 18         |                   |                    | 18         |                   |                    | ns typ                                 | $R_L = 300\ \Omega$ , $C_L = 35\text{ pF}$ ;<br>see Figure 24   |
| Break-Before-Make Time<br>Delay, $t_{OPEN}$                 | 8          | 30                | 30                 | 8          | 30                | 30                 | ns max<br>ns typ                       | $V_{S1} = 2\text{ V}/0\text{ V}$ , $V_{S2} = 0\text{ V}/2\text{ V}$<br>$R_L = 300\ \Omega$ , $C_L = 35\text{ pF}$ |
|   |            | 1                 | 1                  |            | 1                 | 1                  | ns min<br>ns typ                       | $V_S = 2\text{ V}$ ; see Figure 25<br>$R_L = 300\ \Omega$ , $C_L = 35\text{ pF}$                                  |
| $t_{ON}$ (EN)   | 18         | 30                | 30                 | 18         | 30                | 30                 | ns max                                 | $V_S = 2\text{ V}$ ; see Figure 26  |
| $t_{OFF}$ (EN)  | 8          |                   |                    | 8          |                   |                    | ns typ                                 | $R_L = 300\ \Omega$ , $C_L = 35\text{ pF}$  |
|   |            | 15                | 15                 |            | 15                | 15                 | ns max                                 | $V_S = 2\text{ V}$ ; see Figure 26  |
| Charge Injection  | $\pm 3$    |                   |                    | $\pm 3$    |                   |                    | pC typ                                 | $V_S = 1.5\text{ V}$ , $R_S = 0\ \Omega$ ,<br>$C_L = 1\text{ nF}$ ; see Figure 27                                 |
| Off Isolation   | -60        |                   |                    | -60        |                   |                    | dB typ                                 | $R_L = 50\ \Omega$ , $C_L = 5\text{ pF}$ ,<br>$f = 10\text{ MHz}$   |
|   | -80        |                   |                    | -80        |                   |                    | dB typ                                 | $R_L = 50\ \Omega$ , $C_L = 5\text{ pF}$ ,<br>$f = 1\text{ MHz}$ ; see Figure 28                                  |
| Channel-to-Channel Crosstalk                                | -60        |                   |                    | -60        |                   |                    | dB typ                                 | $R_L = 50\ \Omega$ , $C_L = 5\text{ pF}$ ,<br>$f = 10\text{ MHz}$   |
|   | -80        |                   |                    | -80        |                   |                    | dB typ                                 | $R_L = 50\ \Omega$ , $C_L = 5\text{ pF}$ ,<br>$f = 1\text{ MHz}$ ; see Figure 29                                  |
| -3 dB Bandwidth   | 55         |                   |                    | 55         |                   |                    | MHz typ                                | $R_L = 50\ \Omega$ , $C_L = 5\text{ pF}$ ;<br>see Figure 30   |

| Parameter                            | B Version |                   |                    | C Version |                   |                    | Unit   | Test Conditions/<br>Comments  |
|--------------------------------------|-----------|-------------------|--------------------|-----------|-------------------|--------------------|--------|-------------------------------|
|                                      | +25°C     | -40°C to<br>+85°C | -40°C to<br>+125°C | +25°C     | -40°C to<br>+85°C | -40°C to<br>+125°C |        |                               |
| C <sub>S</sub> (Off)                 | 13        |                   |                    | 13        |                   |                    | pF typ | f = 1 MHz                     |
| C <sub>D</sub> (Off)                 |           |                   |                    |           |                   |                    |        |                               |
| ADG708                               | 85        |                   |                    | 85        |                   |                    | pF typ | f = 1 MHz                     |
| ADG709                               | 42        |                   |                    | 42        |                   |                    | pF typ | f = 1 MHz                     |
| C <sub>D</sub> , C <sub>S</sub> (On) |           |                   |                    |           |                   |                    |        |                               |
| ADG708                               | 96        |                   |                    | 96        |                   |                    | pF typ | f = 1 MHz                     |
| ADG709                               | 48        |                   |                    | 48        |                   |                    | pF typ | f = 1 MHz                     |
| POWER REQUIREMENTS                   |           |                   |                    |           |                   |                    |        | V <sub>DD</sub> = 3.3 V       |
| I <sub>DD</sub>                      | 0.001     |                   |                    | 0.001     |                   |                    | μA typ | Digital inputs = 0 V or 3.3 V |
|                                      |           | 1.0               | 1.0                |           | 1.0               | 1.0                | μA max |                               |

<sup>1</sup> Guaranteed by design, not subject to production test.

**DUAL SUPPLY**

$V_{DD} = 2.5 \text{ V} \pm 10\%$ ,  $V_{SS} = -2.5 \text{ V} \pm 10\%$ ,  $GND = 0 \text{ V}$ , unless otherwise noted.

Table 3.

| Parameter   | B Version  |                   |                      | C Version  |                   |                      | Unit                                   | Test Conditions/<br>Comments   |
|---|------------|-------------------|----------------------|------------|-------------------|----------------------|--|--|
|   | +25°C      | -40°C to<br>+85°C | -40°C to<br>+125°C   | +25°C      | -40°C to<br>+85°C | -40°C to<br>+125°C   |  |  |
| <b>ANALOG SWITCH</b>  |            |                   |                      |            |                   |                      |  |  |
| Analog Signal Range   |            |                   | $V_{SS}$ to $V_{DD}$ |            |                   | $V_{SS}$ to $V_{DD}$ | V                                      | $V_S = V_{SS}$ to $V_{DD}$ , $I_{DS} = 10 \text{ mA}$ ;<br>see Figure 20   |
| On Resistance ( $R_{ON}$ )                                  | 2.5        |                   |                      | 2.5        |                   |                      | $\Omega$ typ                           |  |
| On Resistance Match Between<br>Channels ( $\Delta R_{ON}$ ) | 4.5        | 5                 | 7                    | 4.5        | 5                 | 7                    | $\Omega$ max                           | $V_S = V_{SS}$ to $V_{DD}$ , $I_{DS} = 10 \text{ mA}$<br>$V_S = V_{SS}$ to $V_{DD}$ , $I_{DS} = 10 \text{ mA}$   |
|   | 0.4        |                   |                      | 0.4        |                   |                      | $\Omega$ typ                           |  |
| On Resistance Flatness ( $R_{FLAT(ON)}$ )                   |            | 0.8               | 1.5                  |            | 0.8               | 1.5                  | $\Omega$ max                           | $V_S = V_{SS}$ to $V_{DD}$ , $I_{DS} = 10 \text{ mA}$<br>$V_S = V_{SS}$ to $V_{DD}$ , $I_{DS} = 10 \text{ mA}$   |
|   | 0.6        |                   |                      | 0.6        |                   |                      | $\Omega$ typ                           |  |
|   |            | 1.0               | 1.65                 |            | 1.0               | 1.65                 | $\Omega$ max                           |  |
| <b>LEAKAGE CURRENTS</b>                                     |            |                   |                      |            |                   |                      |  |  |
| Source Off Leakage, $I_S$ (Off)                             | $\pm 0.01$ |                   |                      | $\pm 0.01$ |                   |                      | nA typ                                 | $V_{DD} = +2.75 \text{ V}$ , $V_{SS} = -2.75 \text{ V}$<br>$V_S = +2.25 \text{ V}/-1.25 \text{ V}$ ,<br>$V_D = -1.25 \text{ V}/+2.25 \text{ V}$ ;<br>see Figure 21 |
| Drain Off Leakage, $I_D$ (Off)                              | $\pm 0.01$ | $\pm 20$          | $\pm 20$             | $\pm 0.1$  | $\pm 0.3$         | $\pm 1$              | nA max                                 | $V_S = +2.25 \text{ V}/-1.25 \text{ V}$ ,<br>$V_D = -1.25 \text{ V}/+2.25 \text{ V}$ ;<br>see Figure 22  |
|   |            |                   |                      | $\pm 0.01$ |                   |                      | nA typ                                 |  |
| Channel On Leakage, $I_{D, I_S}$ (On)                       | $\pm 0.01$ | $\pm 20$          | $\pm 20$             | $\pm 0.1$  | $\pm 0.75$        | $\pm 6$              | nA max                                 | $V_S = V_D = +2.25 \text{ V}/-1.25 \text{ V}$ ;<br>see Figure 23   |
|   |            |                   |                      | $\pm 0.01$ |                   |                      | nA typ                                 |  |
|   |            | $\pm 20$          | $\pm 20$             | $\pm 0.1$  | $\pm 0.75$        | $\pm 6$              | nA max                                 |  |
| <b>DIGITAL INPUTS</b>                                       |            |                   |                      |            |                   |                      |  |  |
| Input High Voltage, $V_{INH}$                               |            |                   | 1.7                  |            |                   | 1.7                  | V min                                  | $V_{IN} = V_{INL}$ or $V_{INH}$  |
| Input Low Voltage, $V_{INL}$                                |            |                   | 0.7                  |            |                   | 0.7                  | V max                                  |  |
| Input Current   |            |                   |                      |            |                   |                      |  |  |
| $I_{INL}$ or $I_{INH}$                                      | 0.005      |                   | $\pm 0.1$            | 0.005      |                   | $\pm 0.1$            | $\mu\text{A}$ typ<br>$\mu\text{A}$ max |  |
| Digital Input Capacitance, $C_{IN}$                         | 2          |                   |                      | 2          |                   |                      | pF typ                                 |  |
| <b>DYNAMIC CHARACTERISTICS<sup>1</sup></b>                  |            |                   |                      |            |                   |                      |  |  |
| $t_{TRANSITION}$  | 14         |                   |                      | 14         |                   |                      | ns typ                                 | $R_L = 300 \Omega$ , $C_L = 35 \text{ pF}$ ;<br>see Figure 24  |
| Break-Before-Make Time Delay,<br>$t_{OPEN}$                 | 8          | 25                | 25                   | 8          | 25                | 25                   | ns max                                 | $V_S = 1.5 \text{ V}/0 \text{ V}$ ; see Figure 24<br>$R_L = 300 \Omega$ , $C_L = 35 \text{ pF}$  |
|   |            |                   |                      |            |                   |                      |  |  |
| $t_{ON}$ (EN)   | 14         | 1                 | 1                    | 14         | 1                 | 1                    | ns min                                 | $V_S = 1.5 \text{ V}$ ; see Figure 25<br>$R_L = 300 \Omega$ , $C_L = 35 \text{ pF}$  |
|   |            |                   |                      |            |                   |                      |  |  |
| $t_{OFF}$ (EN)  | 8          | 25                | 25                   | 8          | 25                | 25                   | ns max                                 | $V_S = 1.5 \text{ V}$ ; see Figure 26<br>$R_L = 300 \Omega$ , $C_L = 35 \text{ pF}$  |
|   |            |                   |                      |            |                   |                      |  |  |
| Charge Injection  | $\pm 3$    | 15                | 15                   | $\pm 3$    | 15                | 15                   | ns max                                 | $V_S = 1.5 \text{ V}$ ; see Figure 26<br>$V_S = 0 \text{ V}$ , $R_S = 0 \Omega$ , $C_L = 1 \text{ nF}$ ;<br>see Figure 27  |
|   |            |                   |                      |            |                   |                      |  |  |
| Off Isolation   | -60        |                   |                      | -60        |                   |                      | dB typ                                 | $R_L = 50 \Omega$ , $C_L = 5 \text{ pF}$ ,<br>$f = 10 \text{ MHz}$   |
|   |            |                   |                      |            |                   |                      |  |  |
|   | -80        |                   |                      | -80        |                   |                      |  | $R_L = 50 \Omega$ , $C_L = 5 \text{ pF}$ ,<br>$f = 1 \text{ MHz}$ ; see Figure 28  |

| Parameter                    | B Version |                   |                    | C Version |                   |                    | Unit              | Test Conditions/<br>Comments   |
|------------------------------|-----------|-------------------|--------------------|-----------|-------------------|--------------------|-------------------|--|
|                              | +25°C     | -40°C to<br>+85°C | -40°C to<br>+125°C | +25°C     | -40°C to<br>+85°C | -40°C to<br>+125°C |                   |  |
| Channel-to-Channel Crosstalk | -60       |                   |                    | -60       |                   |                    | dB typ            | $R_L = 50\ \Omega$ , $C_L = 5\ \text{pF}$ ,<br>$f = 10\ \text{MHz}$                |
|                              | -80       |                   |                    | -80       |                   |                    | dB typ            | $R_L = 50\ \Omega$ , $C_L = 5\ \text{pF}$ ,<br>$f = 1\ \text{MHz}$ ; see Figure 29 |
| -3 dB Bandwidth              | 55        |                   |                    | 55        |                   |                    | MHz typ           | $R_L = 50\ \Omega$ , $C_L = 5\ \text{pF}$ ;<br>see Figure 30                       |
| $C_S$ (Off)                  | 13        |                   |                    | 13        |                   |                    | pF typ            | $f = 1\ \text{MHz}$  |
| $C_D$ (Off)                  |           |                   |                    |           |                   |                    |                   |  |
| ADG708                       | 85        |                   |                    | 85        |                   |                    | pF typ            | $f = 1\ \text{MHz}$  |
| ADG709                       | 42        |                   |                    | 42        |                   |                    | pF typ            | $f = 1\ \text{MHz}$  |
| $C_D$ , $C_S$ (On)           |           |                   |                    |           |                   |                    |                   |  |
| ADG708                       | 96        |                   |                    | 96        |                   |                    | pF typ            | $f = 1\ \text{MHz}$  |
| ADG709                       | 48        |                   |                    | 48        |                   |                    | pF typ            | $f = 1\ \text{MHz}$  |
| POWER REQUIREMENTS           |           |                   |                    |           |                   |                    |                   |  |
| $I_{DD}$                     | 0.001     |                   |                    | 0.001     |                   |                    | $\mu\text{A typ}$ | $V_{DD} = 2.75\ \text{V}$  |
|                              |           | 1.0               | 1.0                |           | 1.0               | 1.0                | $\mu\text{A max}$ | Digital inputs = 0V or 2.75V   |
| $I_{SS}$                     | 0.001     |                   |                    | 0.001     |                   |                    | $\mu\text{A typ}$ | $V_{SS} = -2.75\ \text{V}$   |
|                              |           | 1.0               | 1.0                |           | 1.0               | 1.0                | $\mu\text{A max}$ | Digital inputs = 0V or 2.75V   |

<sup>1</sup> Guaranteed by design not subject to production test.



## ABSOLUTE MAXIMUM RATINGS

$T_A = 25^\circ\text{C}$ , unless otherwise noted.

**Table 4.**

| Parameter  | Rating   |
|--|--|
| $V_{DD}$ to $V_{SS}$   | 7 V  |
| $V_{DD}$ to GND  | -0.3 V to +7 V   |
| $V_{SS}$ to GND  | +0.3 V to -3.5 V   |
| Analog Inputs <sup>1</sup>                                       | $V_{SS} - 0.3\text{ V}$ to $V_{DD} + 0.3\text{ V}$<br>or 30 mA, whichever occurs first |
| Digital Inputs <sup>1</sup>                                      | -0.3 V to $V_{DD} + 0.3\text{ V}$ or<br>30 mA, whichever occurs first                  |
| Peak Current, S or D (Pulsed at 1 ms,<br>10% Duty Cycle Maximum) | 100 mA   |
| Continuous Current, S or D                                       | 30 mA  |
| Operating Temperature  |  |
| Industrial Temperature Range                                     | -40°C to +125°C  |
| Storage Temperature Range  | -65°C to +150°C  |
| Junction Temperature   | 150°C  |
| TSSOP Package, Power Dissipation                                 | 432 mW   |
| $\theta_{JA}$ Thermal Impedance                                  | 150.4°C/W  |
| $\theta_{JC}$ Thermal Impedance                                  | 27.6°C/W   |
| Lead Temperature, Soldering                                      |  |
| Vapor Phase (60 sec)   | 215°C  |
| Infrared (15 sec)  | 220°C  |

<sup>1</sup> Overvoltages at A, EN, S, or D are clamped by internal codes. Current should be limited to the maximum ratings given.

Stresses above those listed under Absolute Maximum Ratings may cause permanent damage to the device. This is a stress rating only; functional operation of the device at these or any other conditions above those indicated in the operational section of this specification is not implied. Exposure to absolute maximum rating conditions for extended periods may affect device reliability.

Only one absolute maximum rating can be applied at any one time.

### ESD CAUTION



**ESD (electrostatic discharge) sensitive device.** Charged devices and circuit boards can discharge without detection. Although this product features patented or proprietary protection circuitry, damage may occur on devices subjected to high energy ESD. Therefore, proper ESD precautions should be taken to avoid performance degradation or loss of functionality.

## PIN CONFIGURATIONS AND FUNCTION DESCRIPTIONS

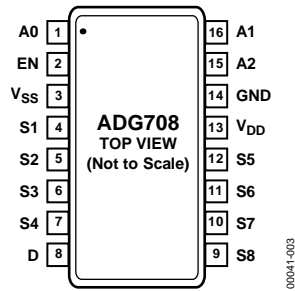

Figure 3. ADG708 Pin Configuration

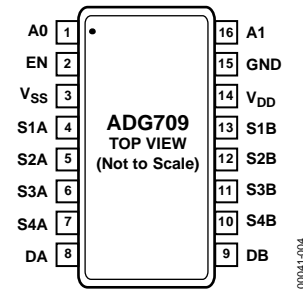

Figure 4. ADG709 Pin Configuration

Table 5. ADG708 Pin Function Descriptions

| Pin No. | Mnemonic        | Description   |
|---------|-----------------|---|
| 1       | A0              | Digital Input. Controls the configuration of the switch, as shown in the truth table (see Table 7).                   |
| 2       | EN              | Digital Input. Controls the configuration of the switch, as shown in the truth table (see Table 7).                   |
| 3       | V <sub>SS</sub> | Most Negative Power Supply Pin in Dual-Supply Applications. For single-supply applications, it should be tied to GND. |
| 4       | S1              | Source Terminal. Can be an input or output.   |
| 5       | S2              | Source Terminal. Can be an input or output.   |
| 6       | S3              | Source Terminal. Can be an input or output.   |
| 7       | S4              | Source Terminal. Can be an input or output.   |
| 8       | D               | Drain Terminal. Can be an input or output.  |
| 9       | S8              | Source Terminal. Can be an input or output.   |
| 10      | S7              | Source Terminal. Can be an input or output.   |
| 11      | S6              | Source Terminal. Can be an input or output.   |
| 12      | S5              | Source Terminal. Can be an input or output.   |
| 13      | V <sub>DD</sub> | Most Positive Power Supply Pin.   |
| 14      | GND             | Ground (0 V) Reference.   |
| 15      | A2              | Digital Input. Controls the configuration of the switch, as shown in the truth table (see Table 7).                   |
| 16      | A1              | Digital Input. Controls the configuration of the switch, as shown in the truth table (see Table 7).                   |

Table 6. ADG709 Pin Function Descriptions

| Pin No. | Mnemonic        | Description   |
|---------|-----------------|---|
| 1       | A0              | Digital Input. Controls the configuration of the switch, as shown in the truth table (see Table 8).                   |
| 2       | EN              | Digital Input. Controls the configuration of the switch, as shown in the truth table (see Table 8).                   |
| 3       | V <sub>SS</sub> | Most Negative Power Supply Pin in Dual-Supply Applications. For single-supply applications, it should be tied to GND. |
| 4       | S1A             | Source Terminal. Can be an input or output.   |
| 5       | S2A             | Source Terminal. Can be an input or output.   |
| 6       | S3A             | Source Terminal. Can be an input or output.   |
| 7       | S4A             | Source Terminal. Can be an input or output.   |
| 8       | DA              | Drain Terminal. Can be an input or output.  |
| 9       | DB              | Drain Terminal. Can be an input or output.  |
| 10      | S4B             | Source Terminal. Can be an input or output.   |
| 11      | S3B             | Source Terminal. Can be an input or output.   |
| 12      | S2B             | Source Terminal. Can be an input or output.   |
| 13      | S1B             | Source Terminal. Can be an input or output.   |
| 14      | V <sub>DD</sub> | Most Positive Power Supply Pin.   |
| 15      | GND             | Ground (0 V) Reference.   |
| 16      | A1              | Digital Input. Controls the configuration of the switch, as shown in the truth table (see Table 8).                   |

**TRUTH TABLES**

Table 7. ADG708 Truth Table

| A2             | A1             | A0             | EN | Switch Condition |
|----------------|----------------|----------------|----|------------------|
| X <sup>1</sup> | X <sup>1</sup> | X <sup>1</sup> | 0  | None             |
| 0              | 0              | 0              | 1  | 1                |
| 0              | 0              | 1              | 1  | 2                |
| 0              | 1              | 0              | 1  | 3                |
| 0              | 1              | 1              | 1  | 4                |
| 1              | 0              | 0              | 1  | 5                |
| 1              | 0              | 1              | 1  | 6                |
| 1              | 1              | 0              | 1  | 7                |
| 1              | 1              | 1              | 1  | 8                |

<sup>1</sup> X = Don't care.

Table 8. ADG709 Truth Table

| A1             | A0             | EN | On Switch Pair |
|----------------|----------------|----|----------------|
| X <sup>1</sup> | X <sup>1</sup> | 0  | None           |
| 0              | 0              | 1  | 1              |
| 0              | 1              | 1  | 2              |
| 1              | 0              | 1  | 3              |
| 1              | 1              | 1  | 4              |

<sup>1</sup> X = Don't care.

TYPICAL PERFORMANCE CHARACTERISTICS



Figure 5. On Resistance as a Function of  $V_D$  ( $V_S$ ) for Single Supply



Figure 8. On Resistance as a Function of  $V_D$  ( $V_S$ ) for Different Temperatures, Single Supply



Figure 6. On Resistance as a Function of  $V_D$  ( $V_S$ ) for Dual Supply



Figure 9. On Resistance as a Function of  $V_D$  ( $V_S$ ) for Different Temperatures, Dual Supply



Figure 7. On Resistance as a Function of  $V_D$  ( $V_S$ ) for Different Temperatures, Single Supply



Figure 10. Leakage Currents as a Function of  $V_D$  ( $V_S$ )



Figure 11. Leakage Currents as a Function of  $V_D$  ( $V_S = V_{DD} - V_D$ )

00041-011

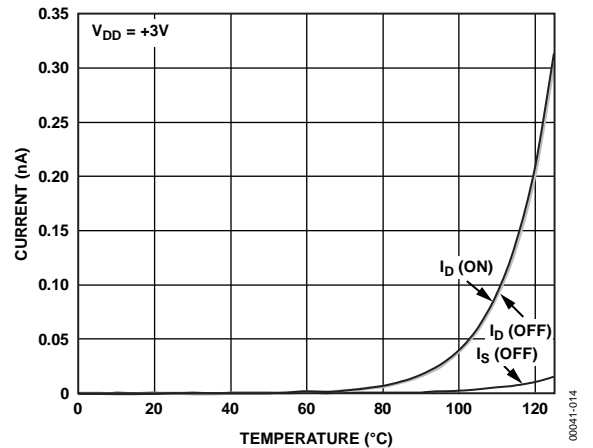

Figure 14. Leakage Currents as a Function of Temperature

00041-014

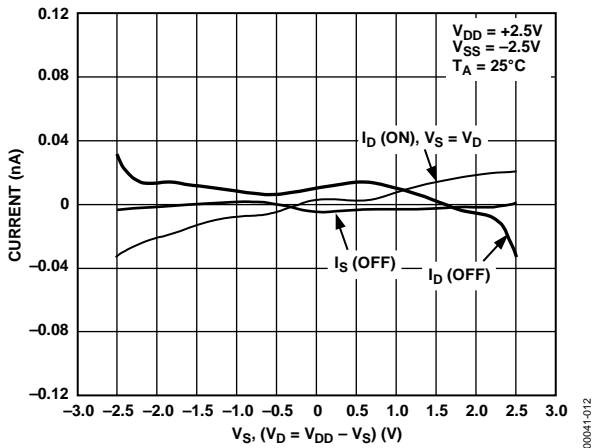

Figure 12. Leakage Currents as a Function of  $V_D$  ( $V_S$ )

00041-012

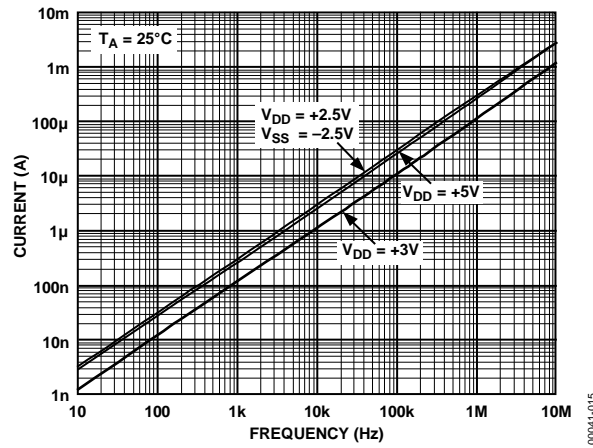

Figure 15. Supply Current vs. Input Switching Frequency

00041-015

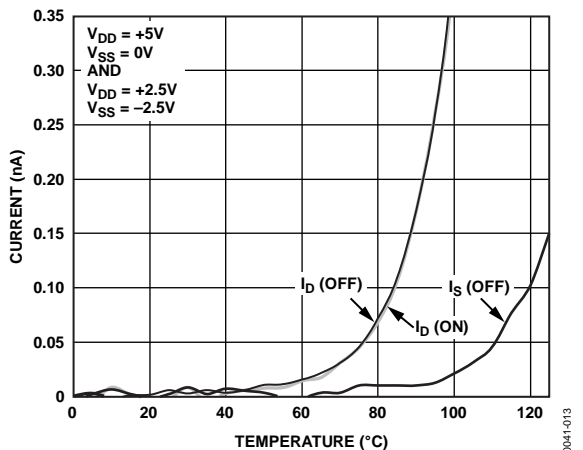

Figure 13. Leakage Currents as a Function of Temperature

00041-013

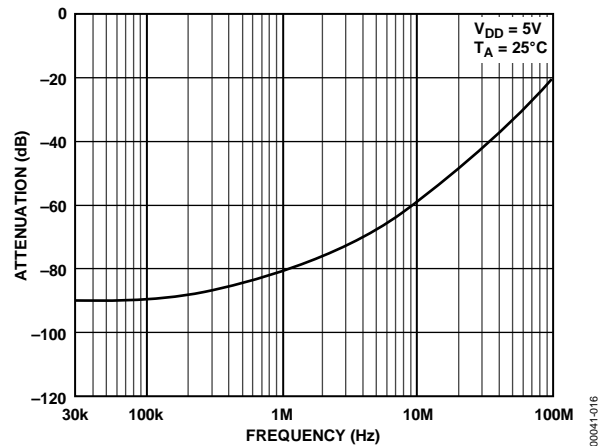

Figure 16. Off Isolation vs. Frequency

00041-016

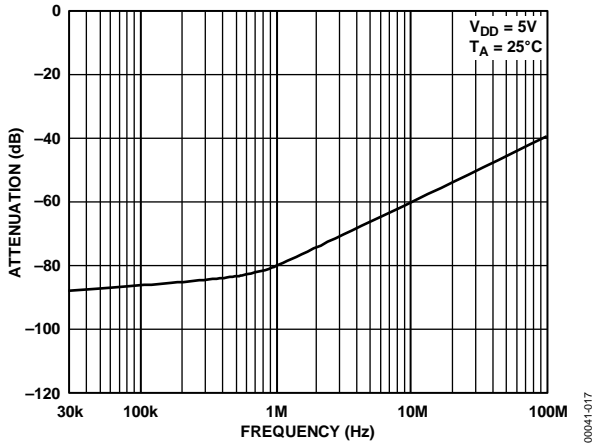

Figure 17. Crosstalk vs. Frequency

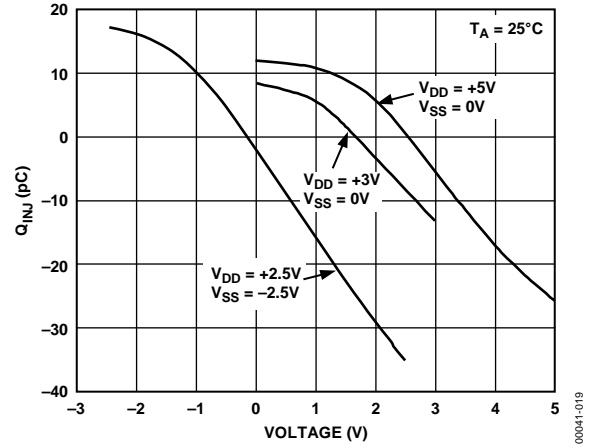

Figure 19. Charge Injection vs. Source Voltage

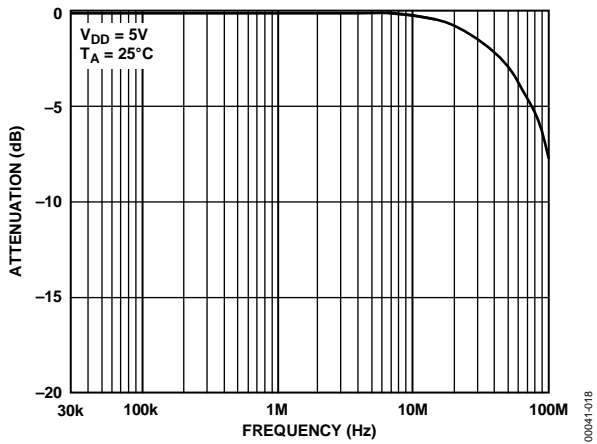

Figure 18. On Response vs. Frequency

TEST CIRCUITS



Figure 20. On Resistance

00041-020



Figure 22. I<sub>D</sub> (OFF)

00041-022



Figure 21. I<sub>S</sub> (OFF)

00041-021



Figure 23. I<sub>D</sub> (ON)

00041-023



\*SIMILAR CONNECTION FOR ADG709.

Figure 24. Switching Time of Multiplexer,  $t_{TRANSITION}$

00041-024

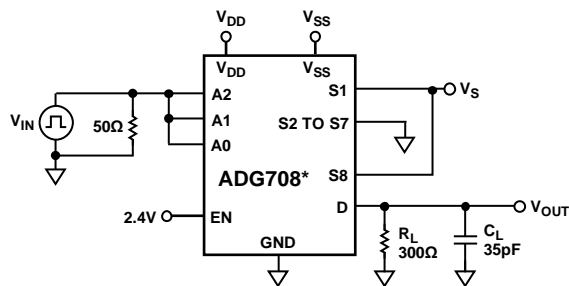
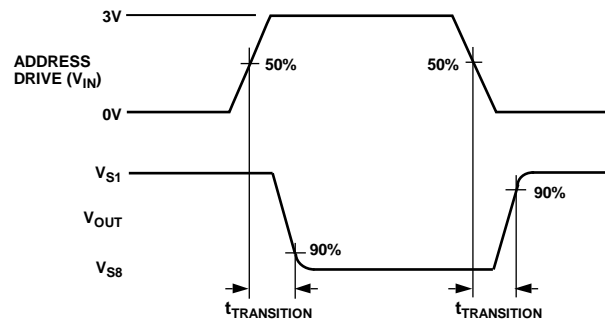

\*SIMILAR CONNECTION FOR ADG709.

Figure 25. Break-Before-Make Delay,  $t_{OPEN}$

00041-025

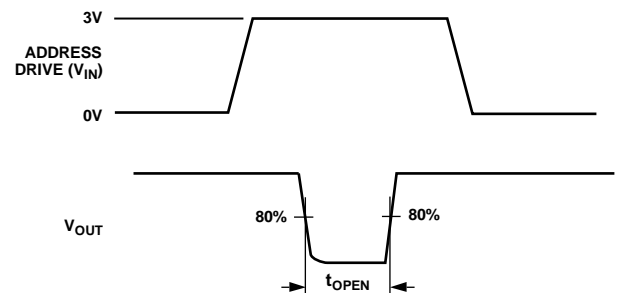



\*SIMILAR CONNECTION FOR ADG709.



00041-026

Figure 26. Enable Delay,  $t_{ON}(EN)$ ,  $t_{OFF}(EN)$



\*SIMILAR CONNECTION FOR ADG709.



00041-027

Figure 27. Charge Injection

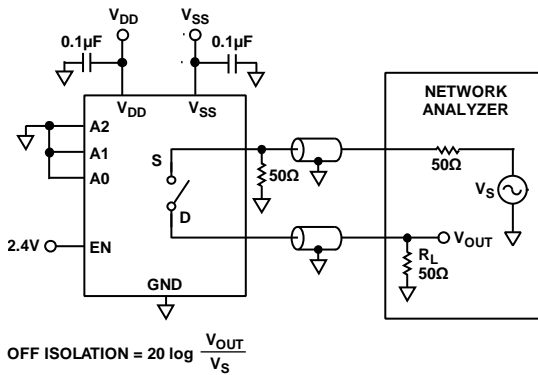

$$\text{OFF ISOLATION} = 20 \log \frac{V_{OUT}}{V_S}$$

00041-028

Figure 28. Off Isolation



\*SIMILAR CONNECTION FOR ADG709.

$$\text{CHANNEL-TO-CHANNEL CROSSTALK} = 20 \log \frac{V_{OUT}}{V_S}$$

00041-029

Figure 29. Channel-to-Channel Crosstalk



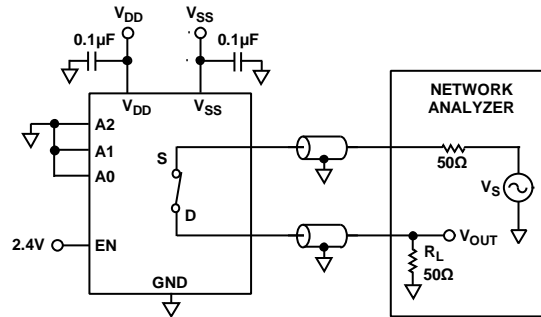

$$\text{INSERTION LOSS} = 20 \log \frac{V_{\text{OUT WITH SWITCH}}}{V_{\text{OUT WITHOUT SWITCH}}}$$

Figure 30. Bandwidth

00041-030

## TERMINOLOGY

### $V_{DD}$

Most positive power supply potential.

### $V_{SS}$

Most negative power supply in a dual-supply application. In single-supply applications, tie  $V_{SS}$  to ground at the device.

### GND

Ground (0 V) reference.

### S

Source terminal. Can be an input or output.

### D

Drain terminal. Can be an input or output.

### Ax

Logic control input.

### EN

Active high enable.

### $R_{ON}$

Ohmic resistance between D and S.

### $R_{FLAT (ON)}$

Flatness is defined as the difference between the maximum and minimum value of on resistance as measured over the specified analog signal range.

### $I_S (Off)$

Source leakage current with the switch off.

### $I_D (Off)$

Drain leakage current with the switch off.

### $I_D, I_S (On)$

Channel leakage current with the switch on.

### $V_D (V_S)$

Analog voltage on Terminal D and Terminal S.

### $C_S (Off)$

Off switch source capacitance. Measured with reference to ground.

### $C_D (Off)$

Off switch drain capacitance. Measured with reference to ground.

### $C_D, C_S (On)$

On switch capacitance. Measured with reference to ground.

### $C_{IN}$

Digital input capacitance.

### $t_{TRANSITION}$

Delay time measured between the 50% and 90% points of the digital inputs and the switch on condition when switching from one address state to another.

### $t_{ON (EN)}$

Delay time between the 50% and 90% points of the EN digital input and the switch on condition.

### $t_{OFF (EN)}$

Delay time between the 50% and 90% points of the EN digital input and the switch off condition.

### $t_{OPEN}$

Off time measured between the 80% points of both switches when switching from one address state to another.

### Off Isolation

A measure of unwanted signal coupling through an off switch.

### Crosstalk

A measure of unwanted signal that is coupled through from one channel to another as a result of parasitic capacitance.

### Charge

A measure of the glitch impulse transferred from injection of the digital input to the analog output during switching.

### Bandwidth

The frequency at which the output is attenuated by 3 dB.

### On Response

The frequency response of the on switch.

### On Loss

The loss due to the on resistance of the switch.

### $V_{INL}$

Maximum input voltage for Logic 0.

### $V_{INH}$

Minimum input voltage for Logic 1.

### $I_{INL} (I_{INH})$

Input current of the digital input.

### $I_{DD}$

Positive supply current.

### $I_{SS}$

Negative supply current.

## APPLICATIONS INFORMATION

### POWER SUPPLY SEQUENCING

When using CMOS devices, take care to ensure correct power supply sequencing. Incorrect power supply sequencing can result in the device being subjected to stresses beyond the maximum ratings listed in Figure 4.

Always apply digital and analog inputs after power supplies and ground. For single-supply operation, tie  $V_{SS}$  to GND as close to the device as possible.

OUTLINE DIMENSIONS

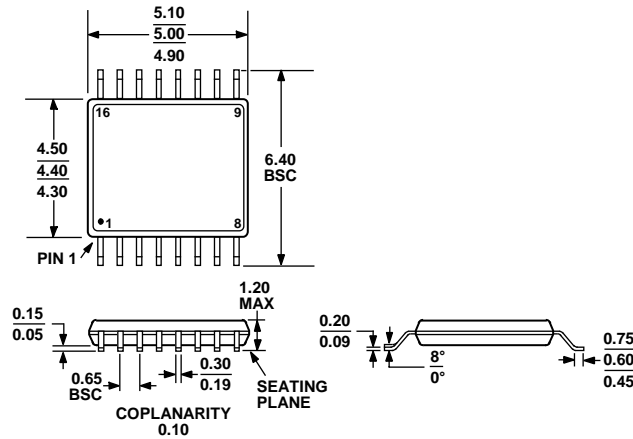

COMPLIANT TO JEDEC STANDARDS MO-153-AB

Figure 31. 16-Lead Thin Shrink Small Outline Package [TSSOP] (RU-16)

Dimensions shown in millimeters

ORDERING GUIDE

| Model <sup>1, 2</sup> | Temperature Range | Package Description                               | Package Option |
|-----------------------|-------------------|---|----------------|
| ADG708BRU             | -40°C to +125°C   | 16-Lead Thin Shrink Small Outline Package [TSSOP] | RU-16          |
| ADG708BRU-REEL        | -40°C to +125°C   | 16-Lead Thin Shrink Small Outline Package [TSSOP] | RU-16          |
| ADG708BRU-REEL7       | -40°C to +125°C   | 16-Lead Thin Shrink Small Outline Package [TSSOP] | RU-16          |
| ADG708BRUZ            | -40°C to +125°C   | 16-Lead Thin Shrink Small Outline Package [TSSOP] | RU-16          |
| ADG708BRUZ-REEL       | -40°C to +125°C   | 16-Lead Thin Shrink Small Outline Package [TSSOP] | RU-16          |
| ADG708BRUZ-REEL7      | -40°C to +125°C   | 16-Lead Thin Shrink Small Outline Package [TSSOP] | RU-16          |
| ADG708CRU             | -40°C to +125°C   | 16-Lead Thin Shrink Small Outline Package [TSSOP] | RU-16          |
| ADG708CRU-REEL        | -40°C to +125°C   | 16-Lead Thin Shrink Small Outline Package [TSSOP] | RU-16          |
| ADG708CRUZ            | -40°C to +125°C   | 16-Lead Thin Shrink Small Outline Package [TSSOP] | RU-16          |
| ADG708CRUZ-REEL       | -40°C to +125°C   | 16-Lead Thin Shrink Small Outline Package [TSSOP] | RU-16          |
| ADG708CRUZ-REEL7      | -40°C to +125°C   | 16-Lead Thin Shrink Small Outline Package [TSSOP] | RU-16          |
| ADW54008-OREEL7       | -40°C to +125°C   | 16-Lead Thin Shrink Small Outline Package [TSSOP] | RU-16          |
| ADG709BRU             | -40°C to +125°C   | 16-Lead Thin Shrink Small Outline Package [TSSOP] | RU-16          |
| ADG709BRU-REEL        | -40°C to +125°C   | 16-Lead Thin Shrink Small Outline Package [TSSOP] | RU-16          |
| ADG709BRU-REEL7       | -40°C to +125°C   | 16-Lead Thin Shrink Small Outline Package [TSSOP] | RU-16          |
| ADG709BRUZ            | -40°C to +125°C   | 16-Lead Thin Shrink Small Outline Package [TSSOP] | RU-16          |
| ADG709BRUZ-REEL       | -40°C to +125°C   | 16-Lead Thin Shrink Small Outline Package [TSSOP] | RU-16          |
| ADG709BRUZ-REEL7      | -40°C to +125°C   | 16-Lead Thin Shrink Small Outline Package [TSSOP] | RU-16          |
| ADG709CRU-REEL7       | -40°C to +125°C   | 16-Lead Thin Shrink Small Outline Package [TSSOP] | RU-16          |
| ADG709CRUZ            | -40°C to +125°C   | 16-Lead Thin Shrink Small Outline Package [TSSOP] | RU-16          |
| ADG709CRUZ-REEL       | -40°C to +125°C   | 16-Lead Thin Shrink Small Outline Package [TSSOP] | RU-16          |
| ADG709CRUZ-REEL7      | -40°C to +125°C   | 16-Lead Thin Shrink Small Outline Package [TSSOP] | RU-16          |

<sup>1</sup> Z = RoHS Compliant Part.  
<sup>2</sup> W = Qualified for Automotive Applications.

AUTOMOTIVE PRODUCTS

The ADW54008 models are available with controlled manufacturing to support the quality and reliability requirements of automotive applications. Note that these automotive models may have specifications that differ from the commercial models; therefore, designers should review the Specifications section of this data sheet carefully. Only the automotive grade products shown are available for use in automotive applications. Contact your local Analog Devices account representative for specific product ordering information and to obtain the specific Automotive Reliability reports for these models.

## Данный компонент на территории Российской Федерации

### Вы можете приобрести в компании MosChip.

Для оперативного оформления запроса Вам необходимо перейти по данной ссылке:

<http://moschip.ru/get-element>

Вы можете разместить у нас заказ для любого Вашего проекта, будь то серийное производство или разработка единичного прибора.

В нашем ассортименте представлены ведущие мировые производители активных и пассивных электронных компонентов.

Нашей специализацией является поставка электронной компонентной базы двойного назначения, продукции таких производителей как XILINX, Intel (ex.ALTERA), Vicor, Microchip, Texas Instruments, Analog Devices, Mini-Circuits, Amphenol, Glenair.

Сотрудничество с глобальными дистрибьюторами электронных компонентов, предоставляет возможность заказывать и получать с международных складов практически любой перечень компонентов в оптимальные для Вас сроки.

На всех этапах разработки и производства наши партнеры могут получить квалифицированную поддержку опытных инженеров.

Система менеджмента качества компании отвечает требованиям в соответствии с ГОСТ Р ИСО 9001, ГОСТ РВ 0015-002 и ЭС РД 009

### Офис по работе с юридическими лицами:

105318, г.Москва, ул.Щербаковская д.3, офис 1107, 1118, ДЦ «Щербаковский»

Телефон: +7 495 668-12-70 (многоканальный)

Факс: +7 495 668-12-70 (доб.304)

E-mail: [info@moschip.ru](mailto:info@moschip.ru)

Skype отдела продаж:

moschip.ru

moschip.ru\_4

moschip.ru\_6

moschip.ru\_9