

THIS DRAWING IS UNPUBLISHED. RELEASED FOR PUBLICATION 20
 © COPYRIGHT 20 BY - ALL RIGHTS RESERVED.

REVISIONS					
P	LTR	DESCRIPTION	DATE	DWN	APVD
4		REVISED TO SHOW ALL WIRES	02OCT2015	JS	CG
5		NOTE CLARIFICATION	03NOV2015	MM	MM
6		REVISED TO SHOW PART CHANGES	29DEC2015	JS	CG

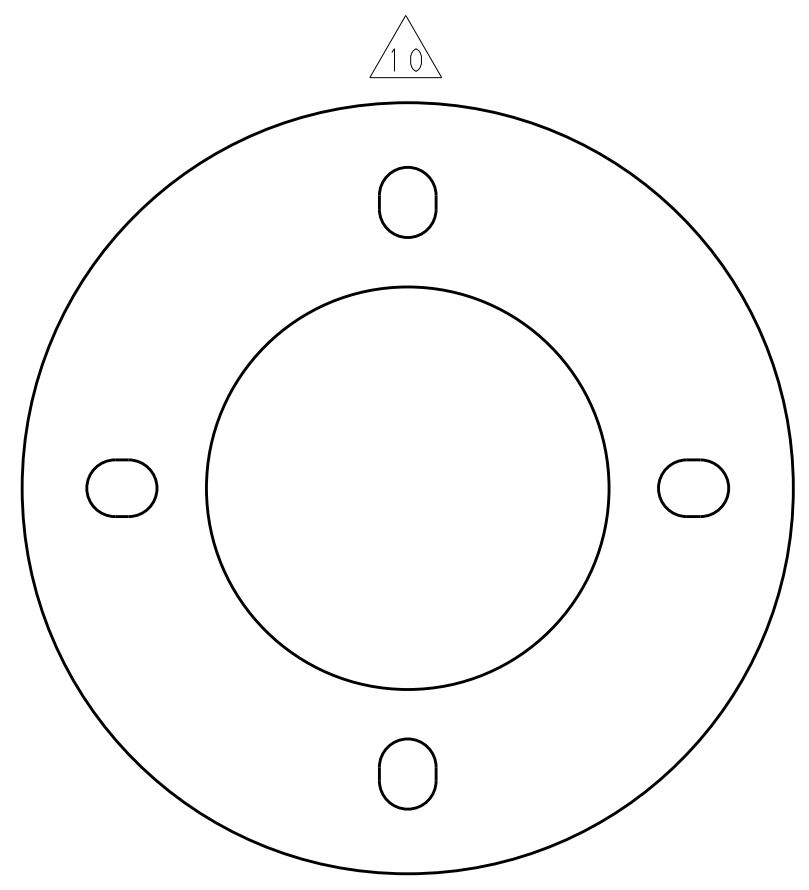

SEE SHEET 2 FOR WIRING COLOR CODE

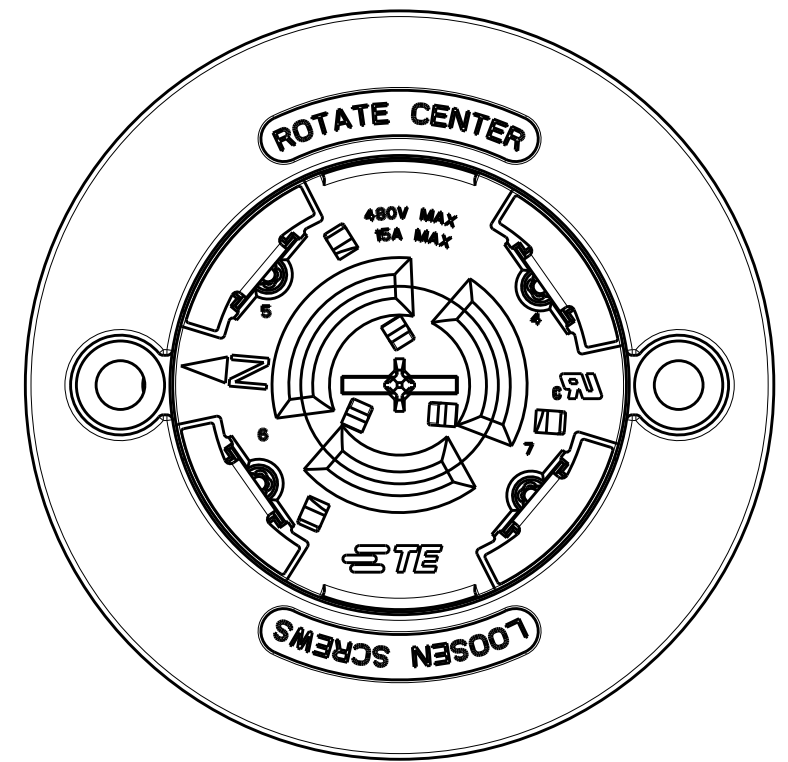
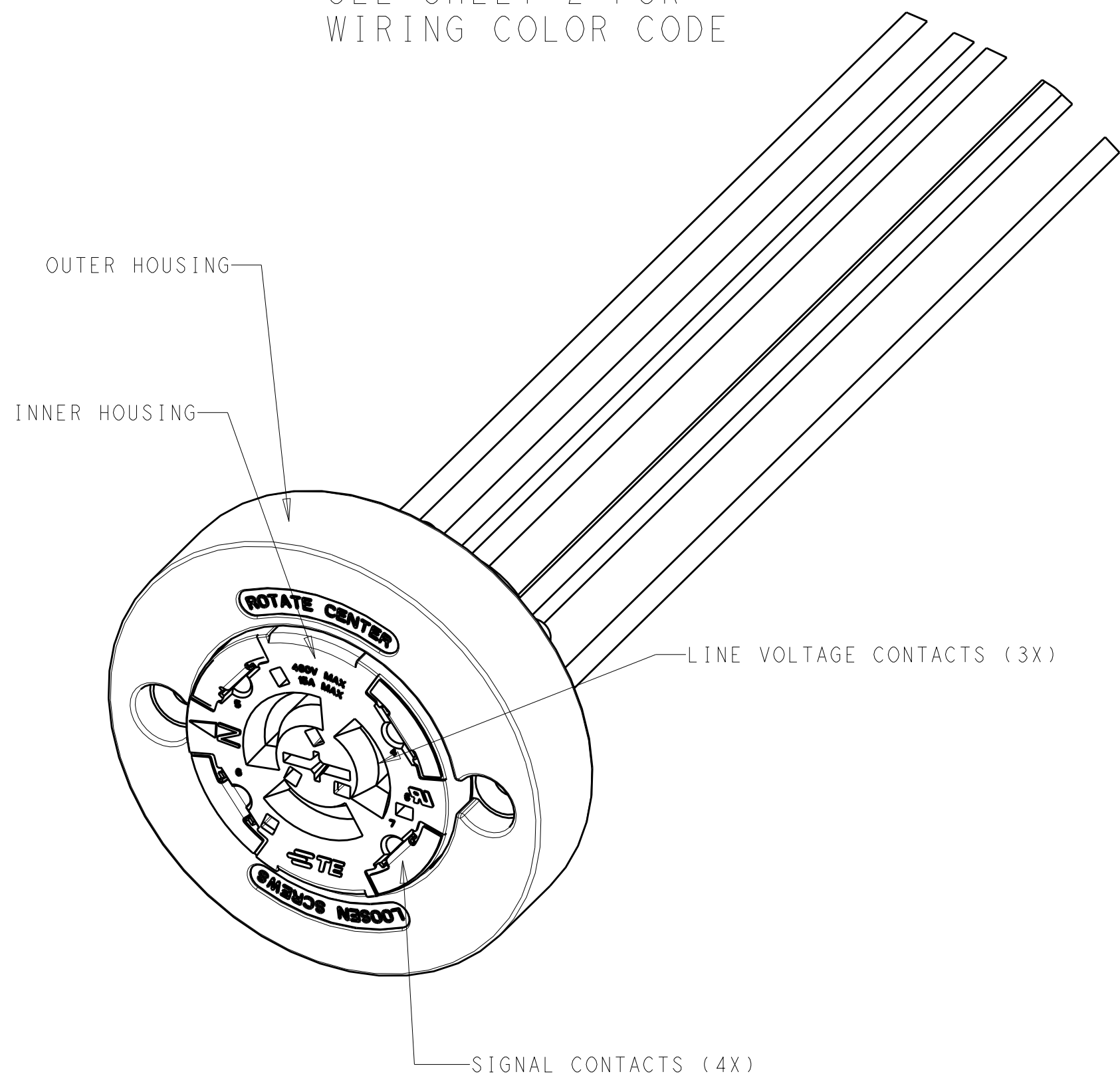

NOTES:

1. MATERIALS:
 HOUSINGS: GLASS-FILLED THERMOPLASTIC, UL 94V-0 RATED
 SIGNAL CONTACTS (2 OR 4) AND LINE VOLTAGE CONTACTS (3):
 COPPER ALLOY
2. FINISH:
 SIGNAL CONTACTS (2 OR 4): NICKEL UNDERPLATE ENTIRE
 CONTACT 0.127 μm MIN THICK. GOLD PLATE CONTACT
 PAD AREA (MATING FACE SIDE ONLY) 0.76 μm MIN THICK.
 MATTE TIN PLATE TAB ON BOTH SIDES 0.30 μm MIN THICK.
 LINE VOLTAGE CONTACTS (3): TIN PLATE.
3. LINE VOLTAGE CONDUCTORS (3):
 14 AWG, 600V, 150°C RATED, COPPER 41/30 STRANDED
 PER UL STYLE AWM 3321.
4. MATING INTERFACE PER ANSI C136.41-2013.
5. OPTIONAL SIGNAL CONTACTS (2) SUPPLIED WITH -2 AND -4 ONLY.
6. SIGNAL CONDUCTORS (2 OR 4):
 18 AWG, 600V, 150°C RATED, 16/30 STRANDED,
 PER UL STYLE AWM 3321.
7. LINE VOLTAGE CONDUCTORS (3):
 14 AWG, 600V, 105°C RATED, COPPER 41/30 STRANDED.
 PER UL STYLE AWM 1015.
8. SIGNAL CONDUCTORS (2 OR 4):
 18 AWG, 600V, 105°C RATED, COPPER 16/30 STRANDED.
 PER UL STYLE AWM 1015.
9. LUBRICATION: GOLD PLATED CONTACT PAD SURFACES OF SIGNAL
 CONTACTS ARE LUBRICATED WITH A TRANSPARENT (NON-VISIBLE)
 LUBRICANT TO IMPROVE DURABILITY AND PERFORMANCE. AVOID
 CONTACT WITH THESE SURFACES WHICH MAY RESULT IN REMOVAL
 OF LUBRICANT.
10. WHEN INCLUDED: SEALING GASKET (TE P/N 2213626-1)
 SHIPPED IN PLACE ON ASSEMBLY AND RETAINED BY THE WIRE LEAD BUNDLE.

341.1	304.8	291.3	7 AND 8	Y	4 5	2213627-8
341.1	304.8	291.3	7 AND 8	Y	2	2213627-7
341.1	304.8	291.3	3 AND 6	Y	4 5	2213627-6
341.1	304.8	291.3	3 AND 6	Y	2	2213627-5
341.1	304.8	291.3	7 AND 8	N	4 5	2213627-4
341.1	304.8	291.3	7 AND 8	N	2	2213627-3
341.1	304.8	291.3	3 AND 6	N	4 5	2213627-2
341.1	304.8	291.3	3 AND 6	N	2	2213627-1
C	A	B	WIRE STYLE	GASKET 10	SIGNAL CONTACTS QUANTITY	PART NO.
OVERALL LENGTH	WIRE LENGTH					

NEW PRODUCT
 PRELIMINARY
 IN DEVELOPMENT

THIS DRAWING IS A CONTROLLED DOCUMENT.

DIMENSIONS:	TOLERANCES UNLESS OTHERWISE SPECIFIED:	DWN	07APR2015
mm	0 PLC ±	RAWLS	07APR2015
	1 PLC ±	CHK	07APR2015
	2 PLC ±	C	GINGRICH
	3 PLC ±	APVD	07APR2015
	4 PLC ±	C	GINGRICH
	ANGLES ±	NAME	ASSEMBLY ROTATING DIMMING
	FINISH	PRODUCT SPEC	RECEPTACLE (49.22mm),
MATERIAL		108-32059	
		APPLICATION SPEC	
		114-32148	
		WEIGHT	
		Customer Drawing	

SIZE	CAGE CODE	DRAWING NO	RESTRICTED TO
A2	-	C-2213627	-
SCALE	1:2	SHEET	1 OF 3
		REV	6

STE TE Connectivity

PRELIMINARY

THIS DRAWING IS UNPUBLISHED. RELEASED FOR PUBLICATION 20
 © COPYRIGHT 20 BY - ALL RIGHTS RESERVED.

REVISIONS				
P	LTR	DESCRIPTION	DATE	APVD
-	-	SEE SHEET 1	-	-

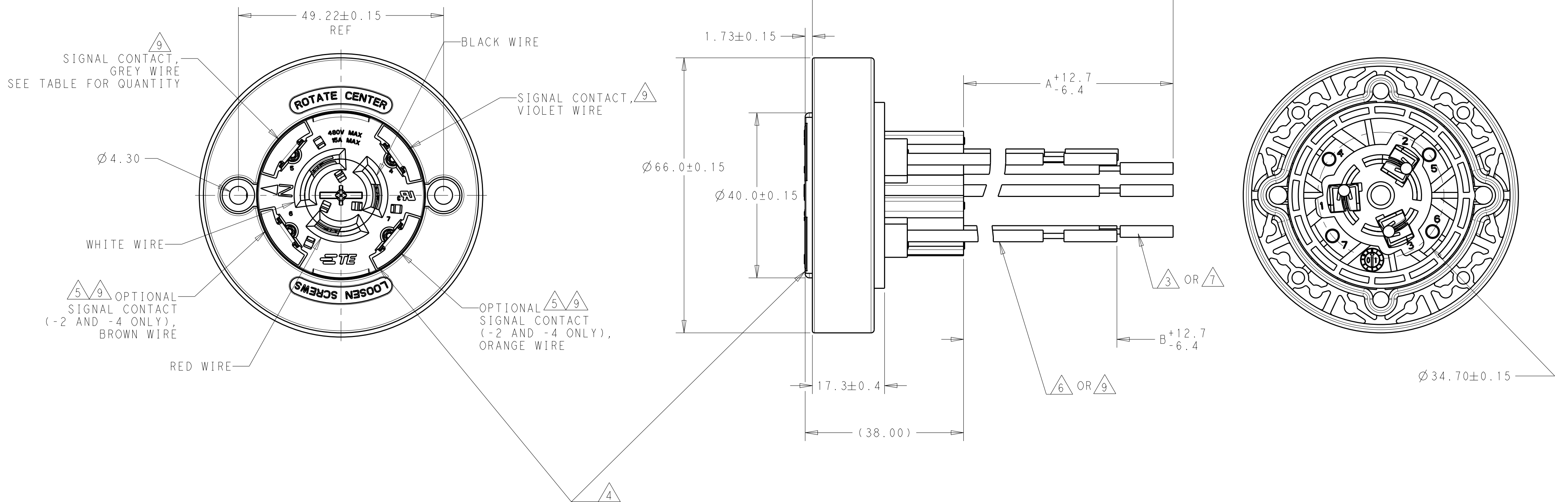

TYPE	POSITION #	WIRE COLOR
POWER	1	BLACK
POWER	2	WHITE
POWER	3	RED
SIGNAL	4	VIOLET
SIGNAL	5	GRAY
SIGNAL	6	BROWN
SIGNAL	7	ORANGE

NEW PRODUCT
 PRELIMINARY
 IN DEVELOPMENT

THIS DRAWING IS A CONTROLLED DOCUMENT.		DWN RAVLS 07APR2015	STE TE Connectivity	
DIMENSIONS: mm		CHK C.GINGRICH 07APR2015		
TOLERANCES UNLESS OTHERWISE SPECIFIED:		APVD C.GINGRICH 07APR2015	NAME ASSEMBLY ROTATING DIMMING RECEPTACLE (49.22mm),	
0 PLC ±		PRODUCT SPEC 108-32059	SIZE A2	
1 PLC ±		APPLICATION SPEC 114-32148	CAGE CODE -	
2 PLC ±		WEIGHT -	DRAWING NO C-2213627	
3 PLC ±		Customer Drawing	RESTRICTED TO -	
4 PLC ±			SCALE 1:2	
ANGLES ±			SHEET 2 OF 3	
FINISH -			REV 6	

THIS DRAWING IS UNPUBLISHED. RELEASED FOR PUBLICATION 20
 © COPYRIGHT 20 BY - ALL RIGHTS RESERVED.

REVISIONS				
P	LTR	DESCRIPTION	DATE	APVD
-		SEE SHEET 1	-	-

IF THE LOCK RING BECOME SEPARATED FROM THE INNER HOUSING ASSEMBLY, FOLLOW THE THESE STEPS TO SNAP IT BACK INTO PLACE
 TO ASSEMBLE THE LOCK RING ONTO THE INNER HOUSING, THESE STEPS MUST BE FOLLOWED.

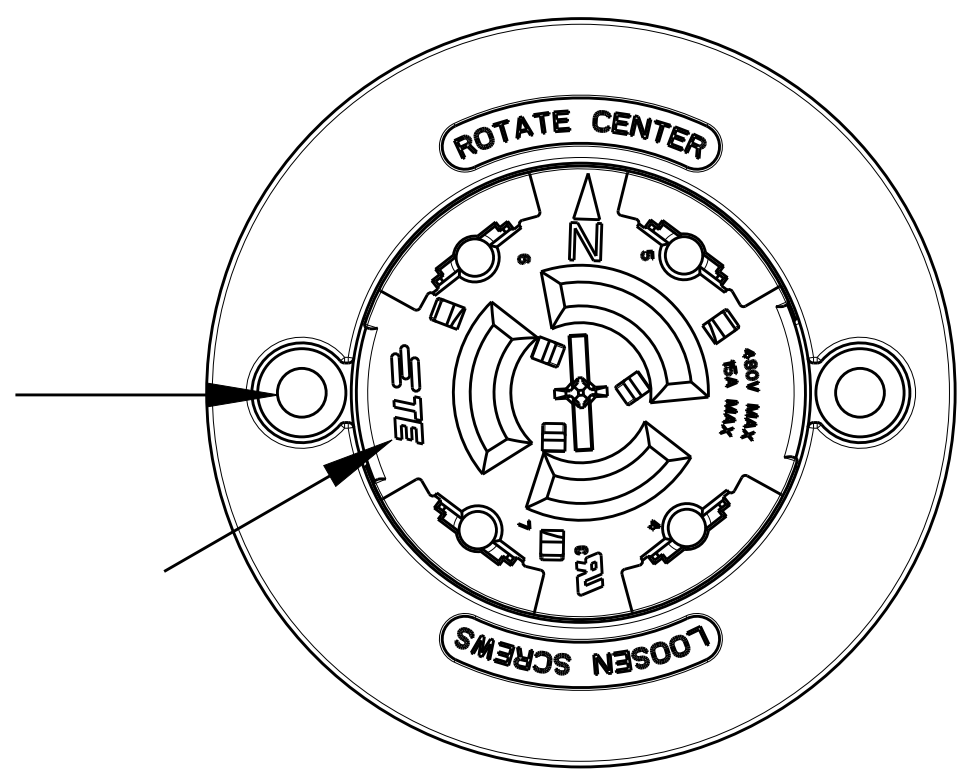

STEP 1: ALIGN THE TE LOGO WITH ONE OF THE SCREW HOLES ON THE LOCK RING.

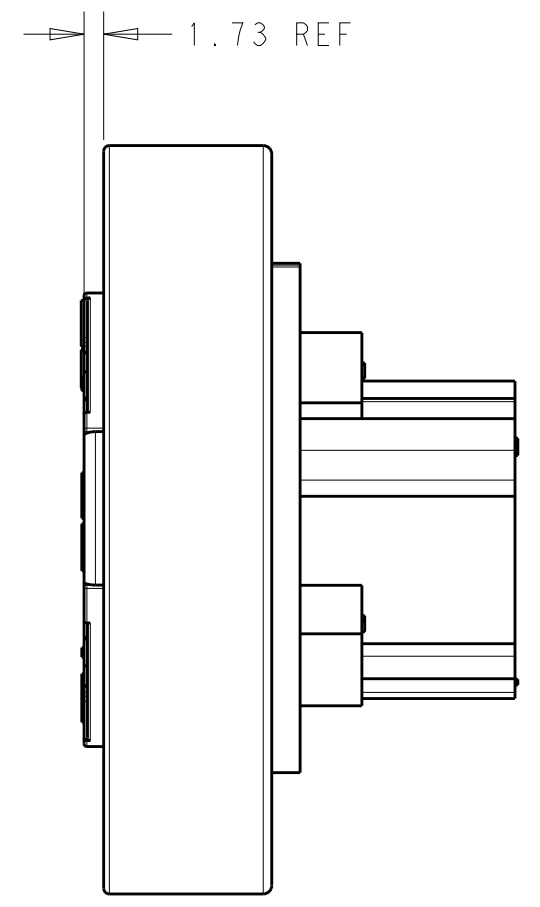

STEP 2: SNAP THE LOCK RING ONTO THE INNER HOUSING ASSEMBLY

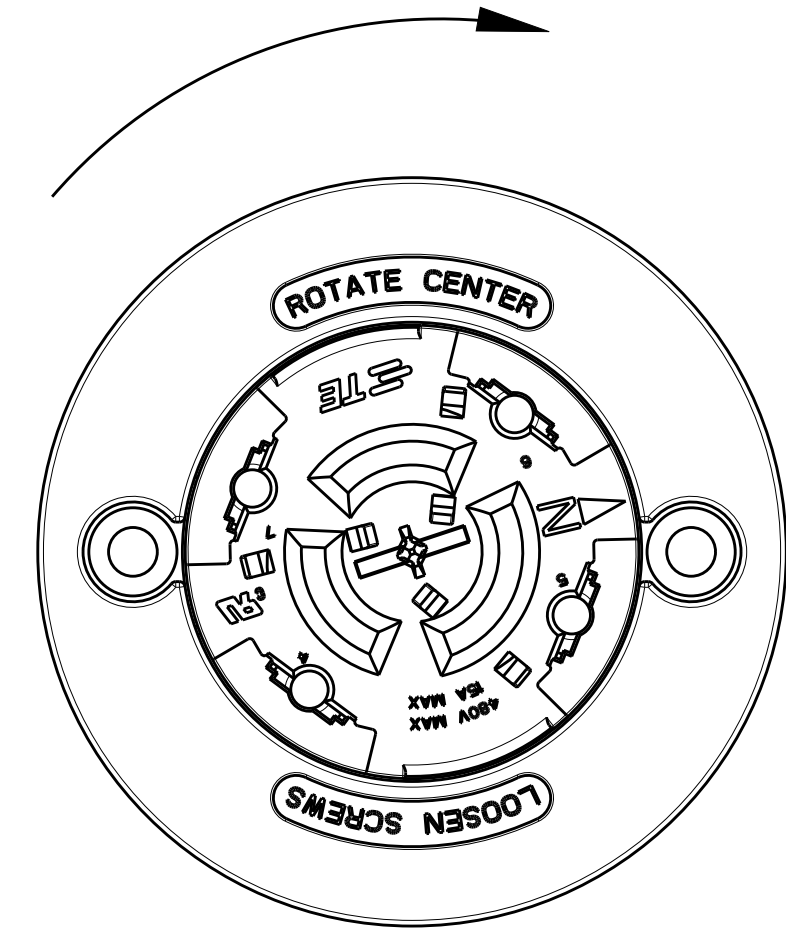

STEP 3: TURN THE LOCK RING FULLY CLOCKWISE UNTIL IT STOPS (THE NORTH INDICATOR WILL BE ADJACENT TO ONE OF THE SCREW HOLES IN THE LOCK RING)

NEW PRODUCT
 PRELIMINARY
 IN DEVELOPMENT

THIS DRAWING IS A CONTROLLED DOCUMENT.		DWN RAVLS 07APR2015	TE Connectivity	
DIMENSIONS: mm		CHK C.GINGRICH 07APR2015		
TOLERANCES UNLESS OTHERWISE SPECIFIED:		APVD C.GINGRICH 07APR2015	NAME ASSEMBLY ROTATING DIMMING RECEPTACLE (49.22mm),	
0 PLC ±		PRODUCT SPEC 108-32059	SIZE A2	
1 PLC ±		APPLICATION SPEC 114-32148	CAGE CODE -	
2 PLC ±		WEIGHT -	DRAWING NO C-2213627	
3 PLC ±		Customer Drawing	RESTRICTED TO -	
4 PLC ±			SCALE 1:2	
ANGLES ±			SHEET 3 OF 3	
FINISH -			REV 6	

Данный компонент на территории Российской Федерации

Вы можете приобрести в компании MosChip.

Для оперативного оформления запроса Вам необходимо перейти по данной ссылке:

<http://moschip.ru/get-element>

Вы можете разместить у нас заказ для любого Вашего проекта, будь то серийное производство или разработка единичного прибора.

В нашем ассортименте представлены ведущие мировые производители активных и пассивных электронных компонентов.

Нашей специализацией является поставка электронной компонентной базы двойного назначения, продукции таких производителей как XILINX, Intel (ex.ALTERA), Vicor, Microchip, Texas Instruments, Analog Devices, Mini-Circuits, Amphenol, Glenair.

Сотрудничество с глобальными дистрибьюторами электронных компонентов, предоставляет возможность заказывать и получать с международных складов практически любой перечень компонентов в оптимальные для Вас сроки.

На всех этапах разработки и производства наши партнеры могут получить квалифицированную поддержку опытных инженеров.

Система менеджмента качества компании отвечает требованиям в соответствии с ГОСТ Р ИСО 9001, ГОСТ РВ 0015-002 и ЭС РД 009

Офис по работе с юридическими лицами:

105318, г.Москва, ул.Щербаковская д.3, офис 1107, 1118, ДЦ «Щербаковский»

Телефон: +7 495 668-12-70 (многоканальный)

Факс: +7 495 668-12-70 (доб.304)

E-mail: info@moschip.ru

Skype отдела продаж:

moschip.ru

moschip.ru_4

moschip.ru_6

moschip.ru_9