

Power Metal Strip® Intelligent Battery Sensor Very Low Value (100 μΩ)

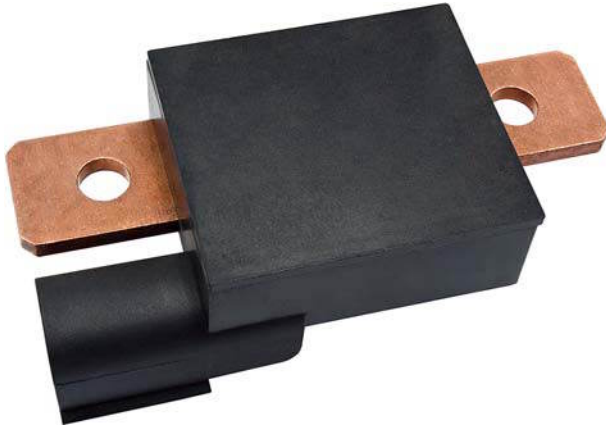

FEATURES

- High voltage, current, and temperature range
- Can be ordered preprogrammed or blank
- Proprietary processing technique produces extremely low resistance value
- Operates as a LIN 2.1 or 2.0 slave
- Circuit sealed for all weather use
- Variable sampling rate
- Capable of withstanding harsh automotive environments
- Integral 4-pin male connector (Molex # MX33482-0401)
- Very low inductance (< 5 nH)
- Material categorization: for definitions of compliance please see www.vishay.com/doc?99912

**RoHS
COMPLIANT**

PRODUCT SUMMARY

Resistance	100 μΩ
Voltage Range	4 V to 18 V
Current Range (Continuous)	± 600 A
Current Range (Pulsed)	± 2000 A
Temperature Range	-40 °C to +115 °C

APPLICATIONS

- Automotive battery management systems
- Lead acid battery monitoring
- Uninterrupted power supplies
- Golf carts
- Electric forklifts
- Personal mobility vehicles
- Medical beds
- Solar chargers
- Renewable energy inverter systems
- Recreational vehicles
- Emergency lighting

GLOBAL PART NUMBER INFORMATION

GLOBAL PART NUMBERING: WBPk600L0A00010001 (WBP, 600 A, 0.000100 Ω)

W	B	P	K	6	0	0	L	0	A	0	0	0	1	0	0	0	1
GLOBAL MODEL (3 digits)	PACKAGING CODE (1 digit)	MAXIMUM CONTINUOUS CURRENT (3 digit)			COMMUNICATION (1 digit)			SPECIAL CHARACTER (1 digit)	CHIPSET CONTROLLER (1 digit)	DESIGN (4 digits)				SOFTWARE (4 digits)			
WBP	K = bulk pack T = tray pack	001 thru 99K as applicable			I = LIN			From 0 to 99 as applicable	A	0000 to 9999 as applicable				From 0 to 9999 as applicable			



ABSOLUTE MAXIMUM RATINGS (all voltages referenced to GND = 0 V)		
PARAMETER	UNIT	RATING
V _{sup} / V _{meas}	V	-22 to +40
LIN	V	-16 to +40
LIN Short-Circuit Current	mA	200
IN+	mV	-200 to +300
IN-	mV	-200 to +300
Operating Temperature ⁽¹⁾	°C	-40 to +115
Storage Temperature	°C	+150

Note

- Stresses beyond those listed under "Absolute Maximum Ratings" may cause permanent damage to the device. These are stress ratings only, and functional operation of the device at these or any other conditions beyond those indicated in the operational sections of the specifications is not implied. Exposure to absolute maximum rating conditions for extended periods may affect device reliability.

RECOMMENDED OPERATING RANGE (all voltages referenced to GND = 0 V)		
PARAMETER	UNIT	RATING
V _{sup} ⁽¹⁾ / V _{meas}	V	4 to 18
IN+	mV	± 200
IN-	mV	± 5
Operating Temperature ⁽²⁾⁽³⁾	°C	-40 to +105

Notes

- ⁽¹⁾ LIN interface requires at least 7 V for functionality.
- ⁽²⁾ Temperature as measured by WBP output.
- ⁽³⁾ Reduced functionality above 105 °C may be experienced.

CURRENT VALUE PER GAIN RANGE			
RANGE	LOWEST I (± A)	HIGHEST I (± A)	RESOLUTION (mA)
1	0.0000	23.0718	0.7153
2	23.0719	46.1436	1.4305
3	46.1437	92.2873	2.8611
4	92.2874	184.5747	5.7222
5	184.5748	369.1495	11.4444
6	369.1496	738.2992	22.8887
7	738.2993	1476.5984	45.7775
8	1476.5985	2000.0000	91.5550

TEMPERATURE ACCURACY

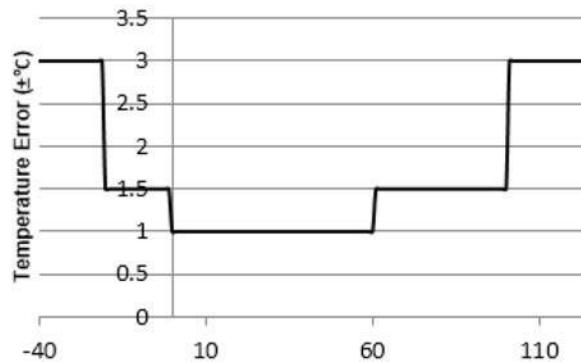

MAXIMUM CURRENT ERROR (CONTINUOUS)

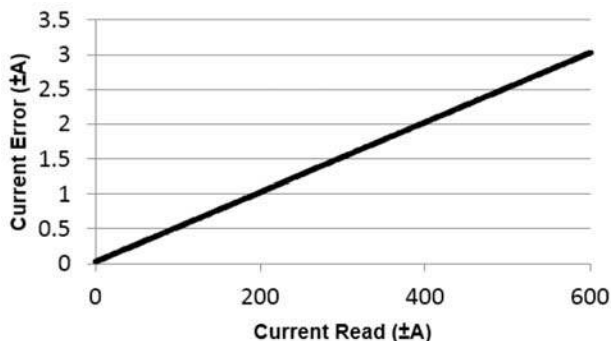

MAXIMUM CURRENT ERROR (FULL RANGE)

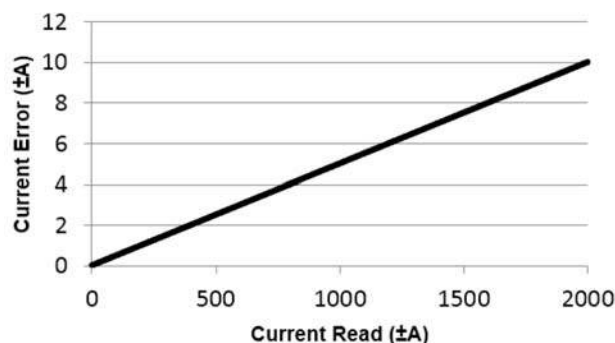



SPECIFICATIONS				
PARAMETER	UNIT	MIN.	TYP.	MAX.
POWER REQUIREMENTS				
Supply Voltage (V_{sup})	V	4	12	18
Supply Current ⁽¹⁾	mA	10	15	20
CURRENT MEASUREMENT				
Resistance	$\mu\Omega$	95	100	105
Current Measurement Range (Continuous)	A		± 600	
Current Measurement Range (Pulsed) ⁽²⁾	A	-2000		2000
Maximum Pulse Energy ⁽²⁾	J		900	
Current Measurement Accuracy	A		$\pm 0.5\% + \text{offset}$	
Current Measurement Offset Error Max.	mA	-30	0	30
Current Measurement Resolution (see Table)	mA	0.715		91.5
VOLTAGE MEASUREMENT				
Voltage Measurement Range	V	4		18
Voltage Measurement Accuracy	mV	-50		50
Voltage Measurement Resolution	mV		0.88	
TEMPERATURE MEASUREMENT				
Temperature Measurement Range	$^{\circ}\text{C}$	-40		125
Temperature Measurement Accuracy (0 $^{\circ}\text{C}$ to 60 $^{\circ}\text{C}$)	$^{\circ}\text{C}$		± 1	
Temperature Measurement Accuracy (-20 $^{\circ}\text{C}$ to 100 $^{\circ}\text{C}$)	$^{\circ}\text{C}$		± 1.5	
Temperature Measurement Accuracy (-40 $^{\circ}\text{C}$ to 115 $^{\circ}\text{C}$)	$^{\circ}\text{C}$		± 3.0	
Temperature Measurement Resolution	$^{\circ}\text{C}$		0.055	
COMMUNICATION				
LIN Specification			LIN 2.1, 2.0	
LIN Baud Rate	bits/s	2000		20000
Data Transfer Rate (Max.) ⁽³⁾	Hz		50	
ADC Sample Rate (I, V, T)	Hz	10	200	1000
CONNECTIONS				
Resistor Mounting Holes	0.276" dia, centered widthwise, 0.492" from end of shunt			
Four Pin Connector	Integral connector mates to standard Molex 33472-0401 female connector			

Notes

- (1) Typical depends on LIN transfer rate.
(2) Temperature as measured by the IBS may not exceed 115 $^{\circ}\text{C}$.
(3) LIN bus constrained.

DIMENSIONS in inches

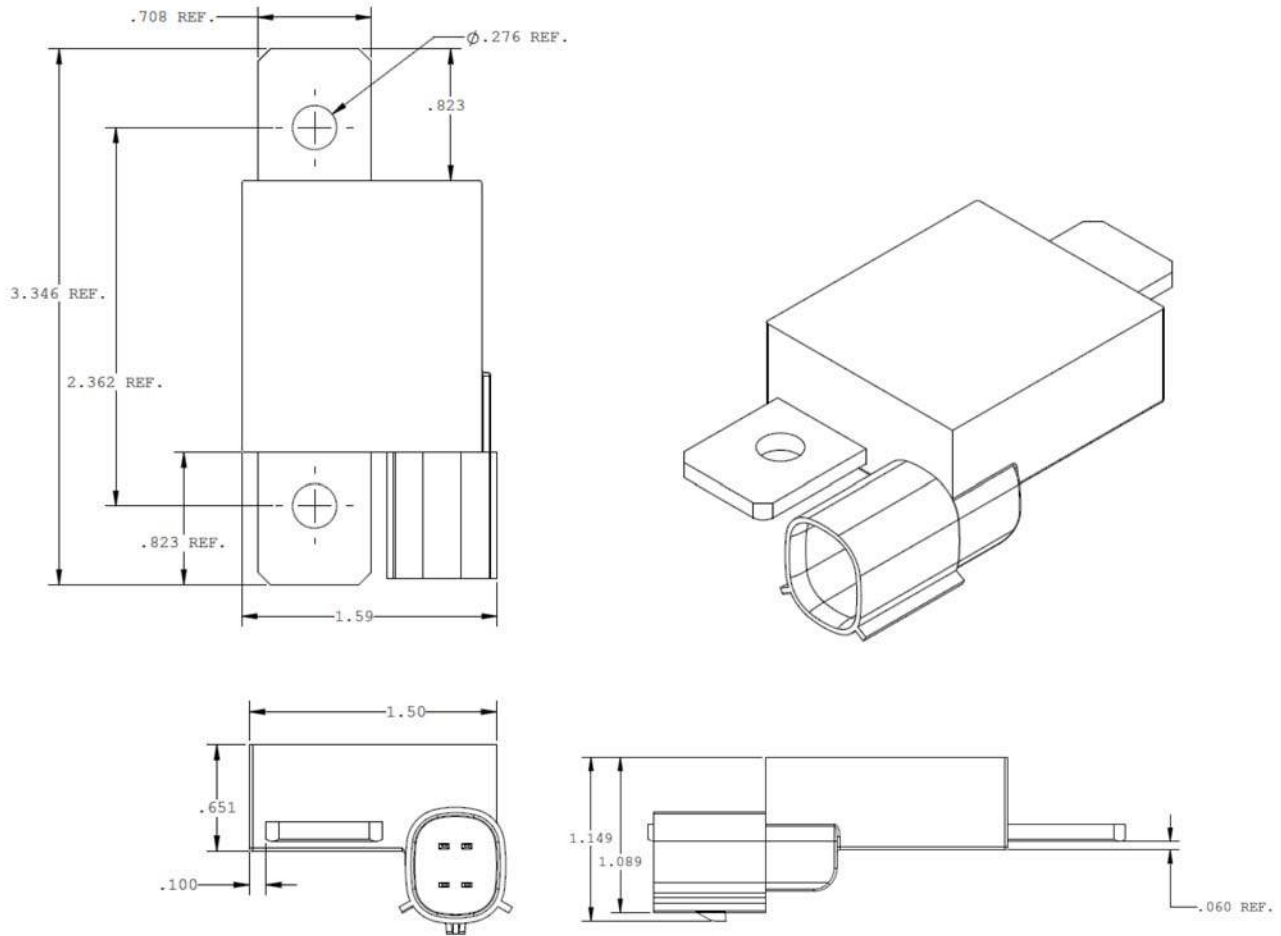

PIN CONFIGURATION AND APPLICATION RECOMMENDATION

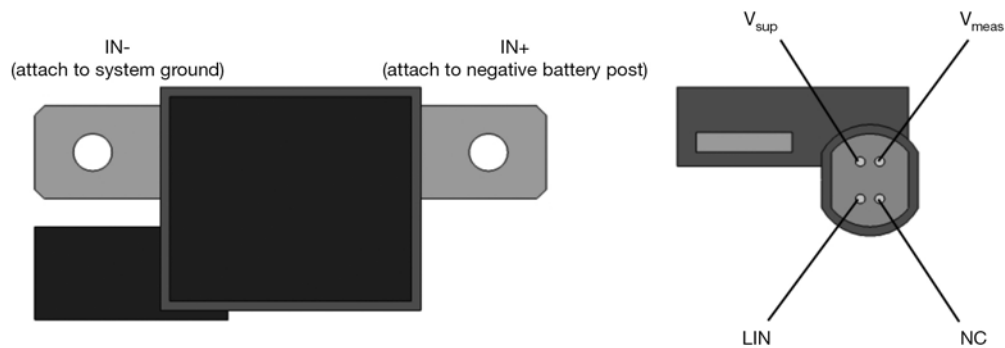



PERFORMANCE (1)	
TEST	CONDITIONS OF TEST
Thermal Shock (2)	-40 °C to + 85 °C, 500 cycles, 30 min at each extreme
High Temperature Exposure	+115 °C for 1000 h
High Temperature Operation	1000 h at +115 °C, 20 A at 1.5 h "ON", 0.5 h "OFF"
Low Temperature Operation	1000 h at -40 °C, 20 A at 1.5 h "ON", 0.5 h "OFF"
Biased Humidity	+85 °C, 85% RH, 1000 h (3)
Mechanical Shock	100 g's for 6 ms, 5 pulses
Vibration	Frequency varied 10 Hz to 2000 Hz in 1 min, 3 directions, 12 h
Moisture Resistance	MIL-STD-202, method 106, 0 % power, 7b not required
Jump Start Test	26 V, 1 min overvoltage jump start simulation
Reverse Polarity Test	-13.5 V, 2 min reverse polarity jump start simulation
Over Voltage Test	18 V, 60 min overvoltage simulation
State Change Waveform Test	State change susceptibility (on / off)
Ground Path Inductance Sensitivity	State change susceptibility (on / off) due to ground path inductance

Notes

- (1) All test are completed on a pass-fail basis, judged by compliance with the datasheet specifications.
- (2) 250 cycles unpowered, 250 powered.
- (3) Circuit powered.



Disclaimer

ALL PRODUCT, PRODUCT SPECIFICATIONS AND DATA ARE SUBJECT TO CHANGE WITHOUT NOTICE TO IMPROVE RELIABILITY, FUNCTION OR DESIGN OR OTHERWISE.

Vishay Intertechnology, Inc., its affiliates, agents, and employees, and all persons acting on its or their behalf (collectively, "Vishay"), disclaim any and all liability for any errors, inaccuracies or incompleteness contained in any datasheet or in any other disclosure relating to any product.

Vishay makes no warranty, representation or guarantee regarding the suitability of the products for any particular purpose or the continuing production of any product. To the maximum extent permitted by applicable law, Vishay disclaims (i) any and all liability arising out of the application or use of any product, (ii) any and all liability, including without limitation special, consequential or incidental damages, and (iii) any and all implied warranties, including warranties of fitness for particular purpose, non-infringement and merchantability.

Statements regarding the suitability of products for certain types of applications are based on Vishay's knowledge of typical requirements that are often placed on Vishay products in generic applications. Such statements are not binding statements about the suitability of products for a particular application. It is the customer's responsibility to validate that a particular product with the properties described in the product specification is suitable for use in a particular application. Parameters provided in datasheets and/or specifications may vary in different applications and performance may vary over time. All operating parameters, including typical parameters, must be validated for each customer application by the customer's technical experts. Product specifications do not expand or otherwise modify Vishay's terms and conditions of purchase, including but not limited to the warranty expressed therein.

Except as expressly indicated in writing, Vishay products are not designed for use in medical, life-saving, or life-sustaining applications or for any other application in which the failure of the Vishay product could result in personal injury or death. Customers using or selling Vishay products not expressly indicated for use in such applications do so at their own risk. Please contact authorized Vishay personnel to obtain written terms and conditions regarding products designed for such applications.

No license, express or implied, by estoppel or otherwise, to any intellectual property rights is granted by this document or by any conduct of Vishay. Product names and markings noted herein may be trademarks of their respective owners.

Material Category Policy

Vishay Intertechnology, Inc. hereby certifies that all its products that are identified as RoHS-Compliant fulfill the definitions and restrictions defined under Directive 2011/65/EU of The European Parliament and of the Council of June 8, 2011 on the restriction of the use of certain hazardous substances in electrical and electronic equipment (EEE) - recast, unless otherwise specified as non-compliant.

Please note that some Vishay documentation may still make reference to RoHS Directive 2002/95/EC. We confirm that all the products identified as being compliant to Directive 2002/95/EC conform to Directive 2011/65/EU.

Vishay Intertechnology, Inc. hereby certifies that all its products that are identified as Halogen-Free follow Halogen-Free requirements as per JEDEC JS709A standards. Please note that some Vishay documentation may still make reference to the IEC 61249-2-21 definition. We confirm that all the products identified as being compliant to IEC 61249-2-21 conform to JEDEC JS709A standards.

Данный компонент на территории Российской Федерации

Вы можете приобрести в компании MosChip.

Для оперативного оформления запроса Вам необходимо перейти по данной ссылке:

<http://moschip.ru/get-element>

Вы можете разместить у нас заказ для любого Вашего проекта, будь то серийное производство или разработка единичного прибора.

В нашем ассортименте представлены ведущие мировые производители активных и пассивных электронных компонентов.

Нашей специализацией является поставка электронной компонентной базы двойного назначения, продукции таких производителей как XILINX, Intel (ex.ALTERA), Vicor, Microchip, Texas Instruments, Analog Devices, Mini-Circuits, Amphenol, Glenair.

Сотрудничество с глобальными дистрибьюторами электронных компонентов, предоставляет возможность заказывать и получать с международных складов практически любой перечень компонентов в оптимальные для Вас сроки.

На всех этапах разработки и производства наши партнеры могут получить квалифицированную поддержку опытных инженеров.

Система менеджмента качества компании отвечает требованиям в соответствии с ГОСТ Р ИСО 9001, ГОСТ РВ 0015-002 и ЭС РД 009

Офис по работе с юридическими лицами:

105318, г.Москва, ул.Щербаковская д.3, офис 1107, 1118, ДЦ «Щербаковский»

Телефон: +7 495 668-12-70 (многоканальный)

Факс: +7 495 668-12-70 (доб.304)

E-mail: info@moschip.ru

Skype отдела продаж:

moschip.ru

moschip.ru_4

moschip.ru_6

moschip.ru_9