

RFLA9002

Dual Low Noise Amplifier Module
698MHz to 960MHz

RFMD's RFLA9002 is a dual Low Noise Amplifier module with external connections to both LNAs. These LNAs feature a shutdown mode to turn off the LNA and provide up to 15dBm drive level without gain expansion and self-biasing in shutdown mode. Noise figure of 1.0dB and P1dB of 0dBm makes this component ideal for receiver input lineups. The RFLA9002 is packaged in a small 4.0mm x 4.0mm leadless laminate MCM. This module is internally matched to 50Ω on all RF ports making it easy to use with no use with no external matching components required.



Package: MCM, 24-pin,
4.0mm x 4.0mm

Features

- Frequency Range 698MHz to 960MHz
- Internally Matched to 50Ω on All RF Ports
- Shutdown Mode with +40dB Isolation
- Gain = 16dB per LNA
- Noise Figure of 1.0dB Typical
- Single +4.0V Supply
- Small 24-Pin, 4.0mm x 4.0mm, Multi-Chip Module (MCM)

Applications

- Cellular Repeaters and Booster Amps
- General Purpose LNA
- ISM Band LNA

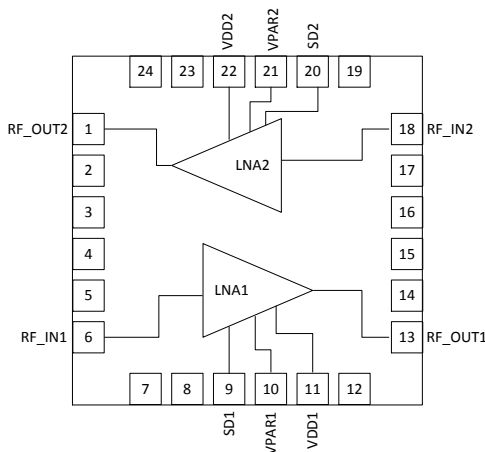

Functional Block Diagram

Ordering Information

RFLA9002SQ	Sample bag with 25 pieces
RFLA9002SR	7" Reel with 100 pieces
RFLA9002TR13	13" Reel with 2500 pieces
RFLA9002PCK-410	698MHz to 960MHz PCBA with 5-piece sample bag

Absolute Maximum Ratings

Parameter	Rating	Unit
Supply Voltage	+5.5	V _{DC}
Control Voltage	+5.5	V _{DC}
DC Supply Current	140	mA
Power Dissipation	770	mW
Max RF Input Power	15	dBm
Operating Temperature (T _{CASE})	-40 to +85	°C
Storage Temperature	-40 to +150	°C
Max Junction Temperature (T _J)	150	°C
ESD Rating - Human Body Model (HBM)	1000 (Class 1C)	V
Moisture Sensitivity Level	MSL3	



Caution! ESD sensitive device.



RFMD Green: RoHS status based on EU Directive 2011/65/EU (at time of this document revision), halogen free per IEC 61249-2-21, < 1000ppm each of antimony trioxide in polymeric materials and red phosphorus as a flame retardant, and <2% antimony in solder.

Exceeding any one or a combination of the Absolute Maximum Rating conditions may cause permanent damage to the device. Extended application of Absolute Maximum Rating conditions to the device may reduce device reliability. Specified typical performance or functional operation of the device under Absolute Maximum Rating conditions is not implied.

Nominal Operating Parameters

Parameter	Specification			Unit	Condition
	Min	Typ	Max		
Individual LNA Performance					T = 25°C, V _{CC} = 4V, Standard Application Circuit
Frequency Range	698		960	MHz	
Gain (On Mode)	16	17.5	19.5	dB	SD = 0V
Noise Figure		1.0	1.4	dB	
Input P1dB	-5	0		dBm	698MHz
	-3	0		dBm	880MHz and 960MHz
Input IP3	1.5	5		dBm	
Gain (Off Mode)		-43		dB	SD = 4V
Gain Delta	>40			dB	Gain LNA (on mode) – Gain LNA (off mode)
Input Return Loss		13		dB	SD = 0V
Output Return Loss		13.5		dB	
Isolation (LNA1 OUT to LNA2 IN)	39	45		dB	
Gain Compression Slope	-1.1	-1	-0.1	dB	Gain compresses monotonically with increased input power once saturated
Overall Power Supply					T = 25°C, V _{CC} = 4V, Standard Application Circuit
Supply Voltage	3.5	4	5	V	
SD Voltage	0		VCC	V	
Logic High	1.7		VCC	V	
Logic Low	0		0.6	V	
Thermal Resistance		139		°C/W	85°C at 4.5V at 35mA of current
Current	8	12	20	mA	On Mode, SD = 0V
	0.01	1	3	mA	Off Mode, SD = 4V

Typical Performance: T=25°C, VDD = 4V unless otherwise noted

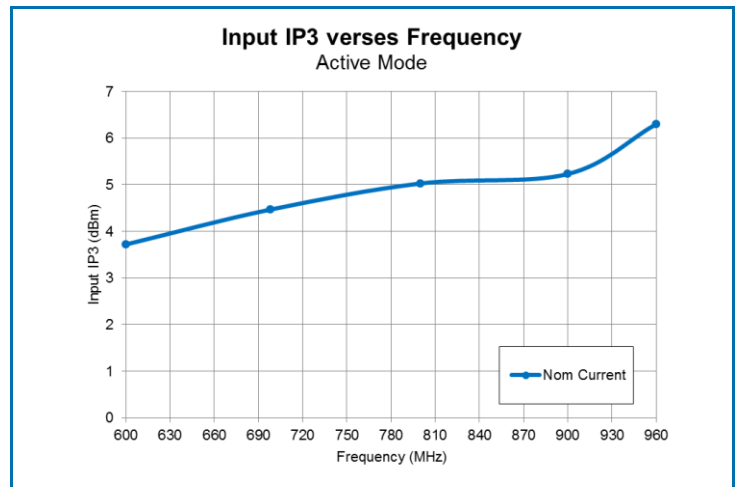
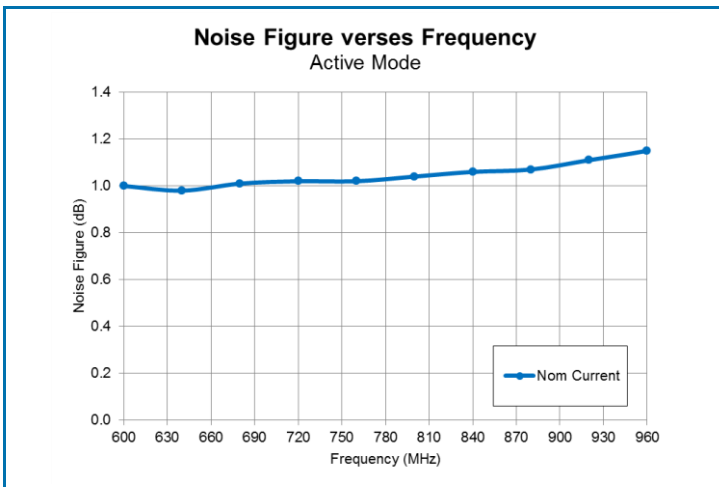
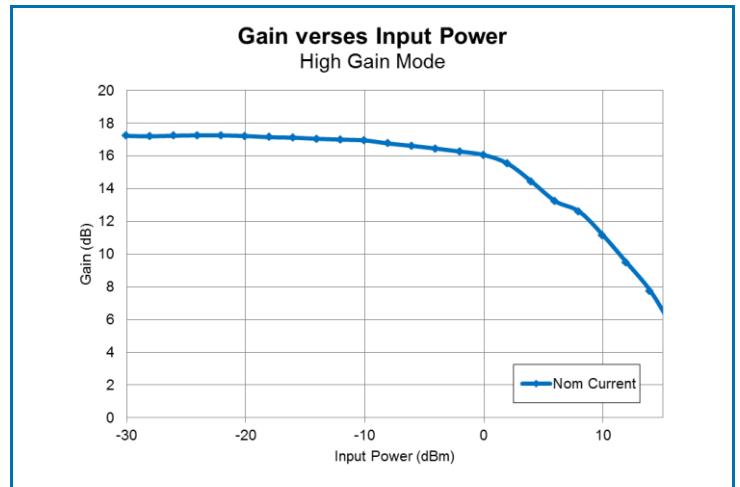
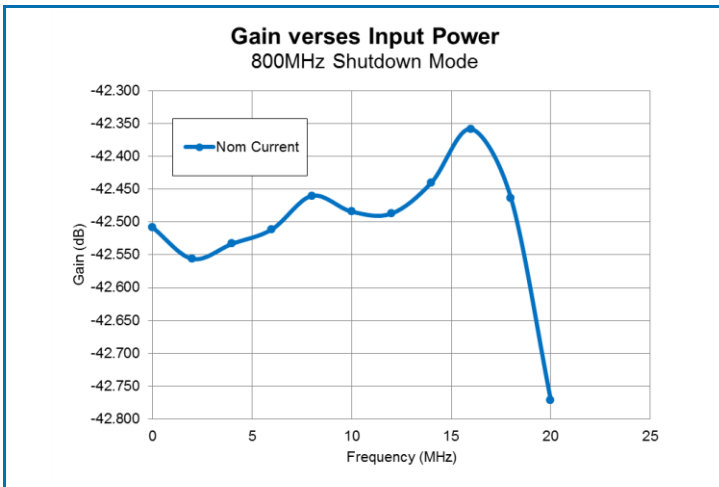
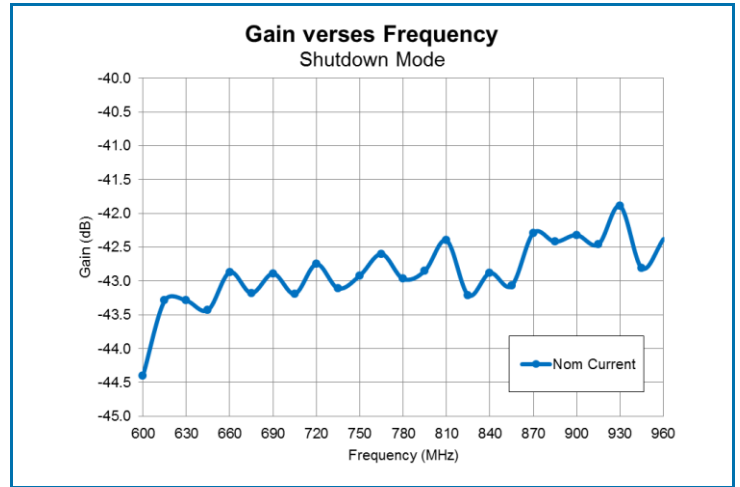
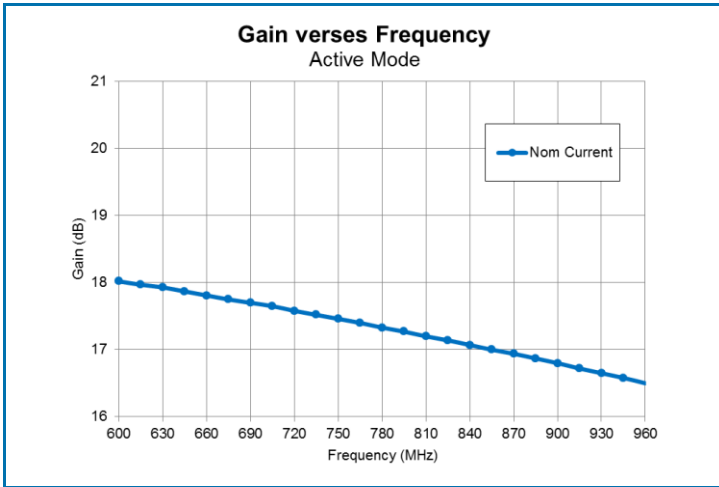

Typical Performance: T=25°C, VDD = 4V unless otherwise noted

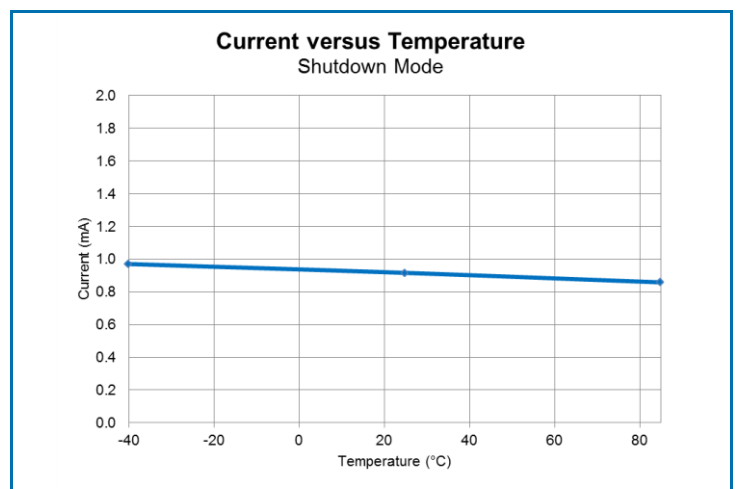
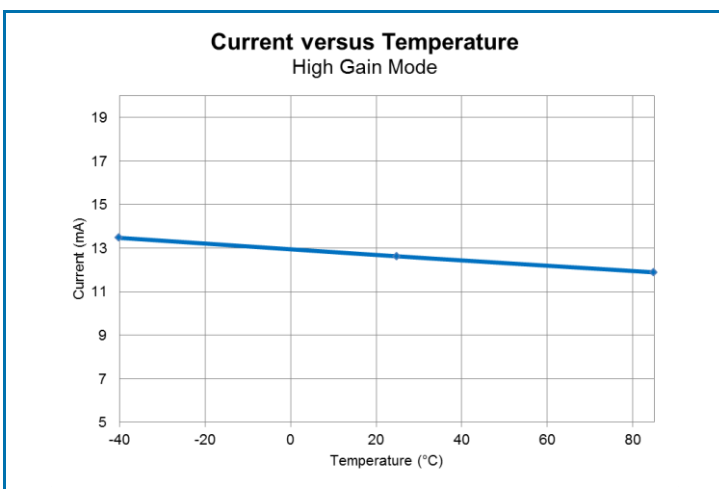
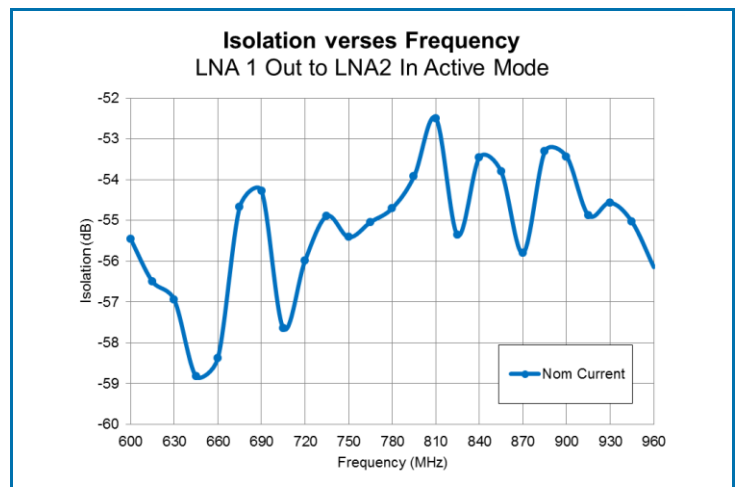
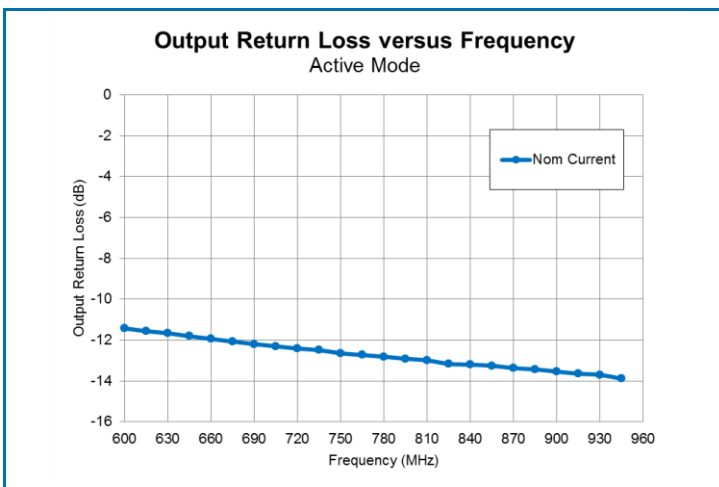
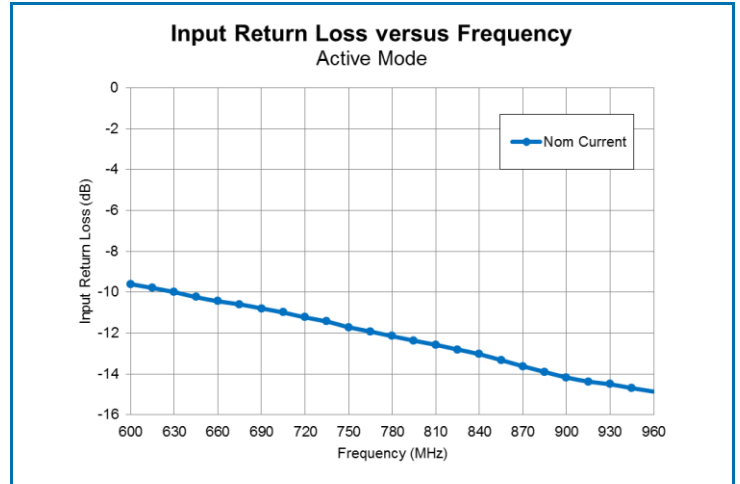
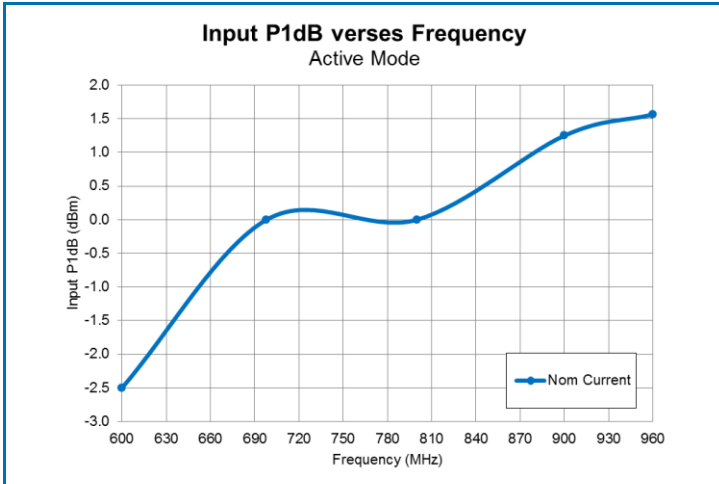

Evaluation Board Schematic

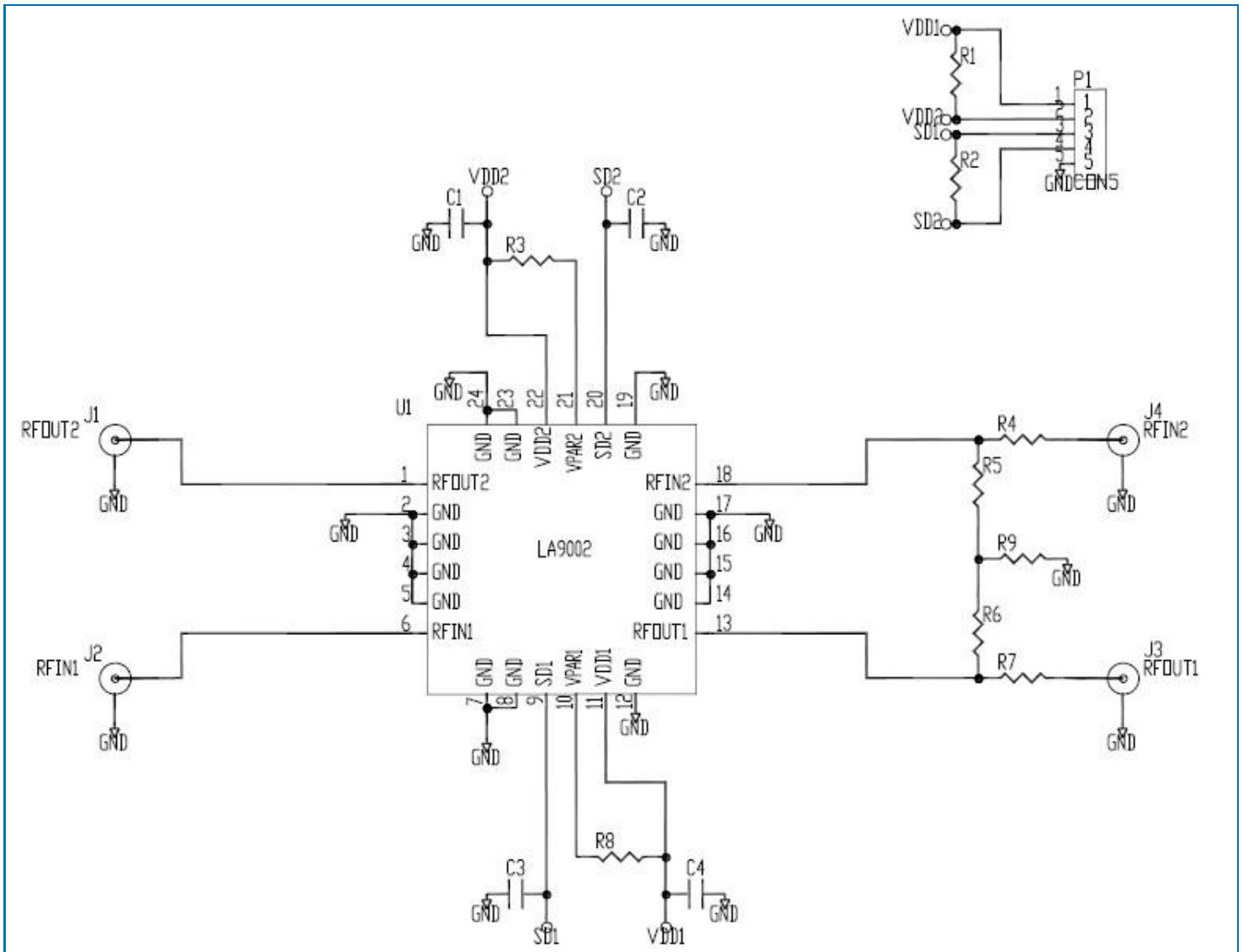

Evaluation Board Bill of Materials (BOM)

Description	Reference Designator	Manufacturer	Manufacturer's P/N
Evaluation Board		DDI	LA9002-410(1)
RFLA9002 Module	U1	RFMD	RFLA9002
CAP, 1 μ F, 10%, 16V, X7R, 0402	C1-C4	Murata Electronics	GRM155R71C104KA88D
CONN, SMA, END LNCH, UNIV, HYB MNT, FLT	J1-J4	Heilind Electronics	PER MAT-21-1038
RES, 0 Ω , 0402	R5-R6	Kamaya, Inc.	RMC1/16SJPTH
CONN, HDR, ST, PLRZD, 9-PIN	P1	ITW Pancon	MPSS100-5C
DNP	R1-R4*, R7-R9*		

Note: Parts with * following the Reference Designators should not be populated on PCBA.

Evaluation Board Assembly Drawing

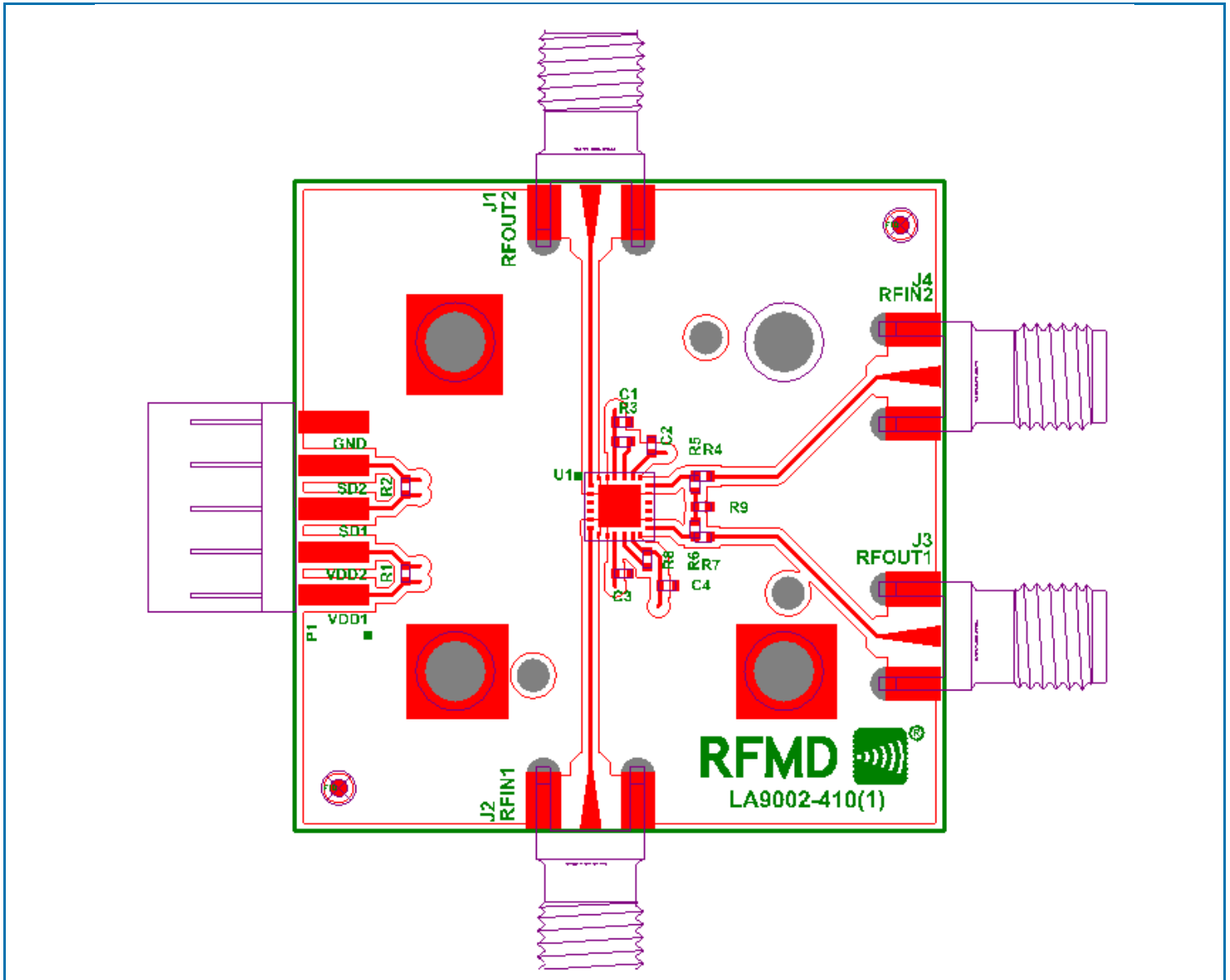

Pin Names and Descriptions

Pin	Name	Description
1	RF_OUT2	RF Output; Internally 50Ω matched and DC blocked
2	GND	Connect to low inductance path to ground
3	GND	Connect to low inductance path to ground
4	GND	Connect to low inductance path to ground
5	GND	Connect to low inductance path to ground
6	RF_IN1	RF Input; Internally 50Ω matched and DC blocked
7	GND	Connect to low inductance path to ground
8	GND	Connect to low inductance path to ground
9	SD1	Shut down pin for LNA1
10	VPAR1	Connection for external resistor to raise current when connected from this pad to V _{DD} and to lower current when connected from this pad to ground
11	VDD	VDD supply, 10nF decoupling internal, supply for LNA1
12	GND	Connect to low inductance path to ground
13	RF_OUT1	RF Output; Internally 50Ω matched and DC blocked
14	GND	Connect to low inductance path to ground
15	GND	Connect to low inductance path to ground
16	GND	Connect to low inductance path to ground
17	GND	Connect to low inductance path to ground
18	RF_IN1	RF Input; Internally 50Ω matched and DC blocked
19	GND	Connect to low inductance path to ground
20	SD2	Shut down pin for LNA2
21	VPAR2	Connection for external resistor to raise current when connected from this pad to V _{DD} and to lower current when connected from this pad to ground
22	VDD2	VDD supply, 10nF decoupling internal, supply for LNA2
23	GND	Connect to low inductance path to ground
24	GND	Connect to low inductance path to ground

Truth Table

	SD1	SD2
LNA1 On	0	X
LNA1 Off	1	X
LNA2 On	X	0
LNA2 Off	X	1

Package Outline Drawing (Dimensions in millimeters)

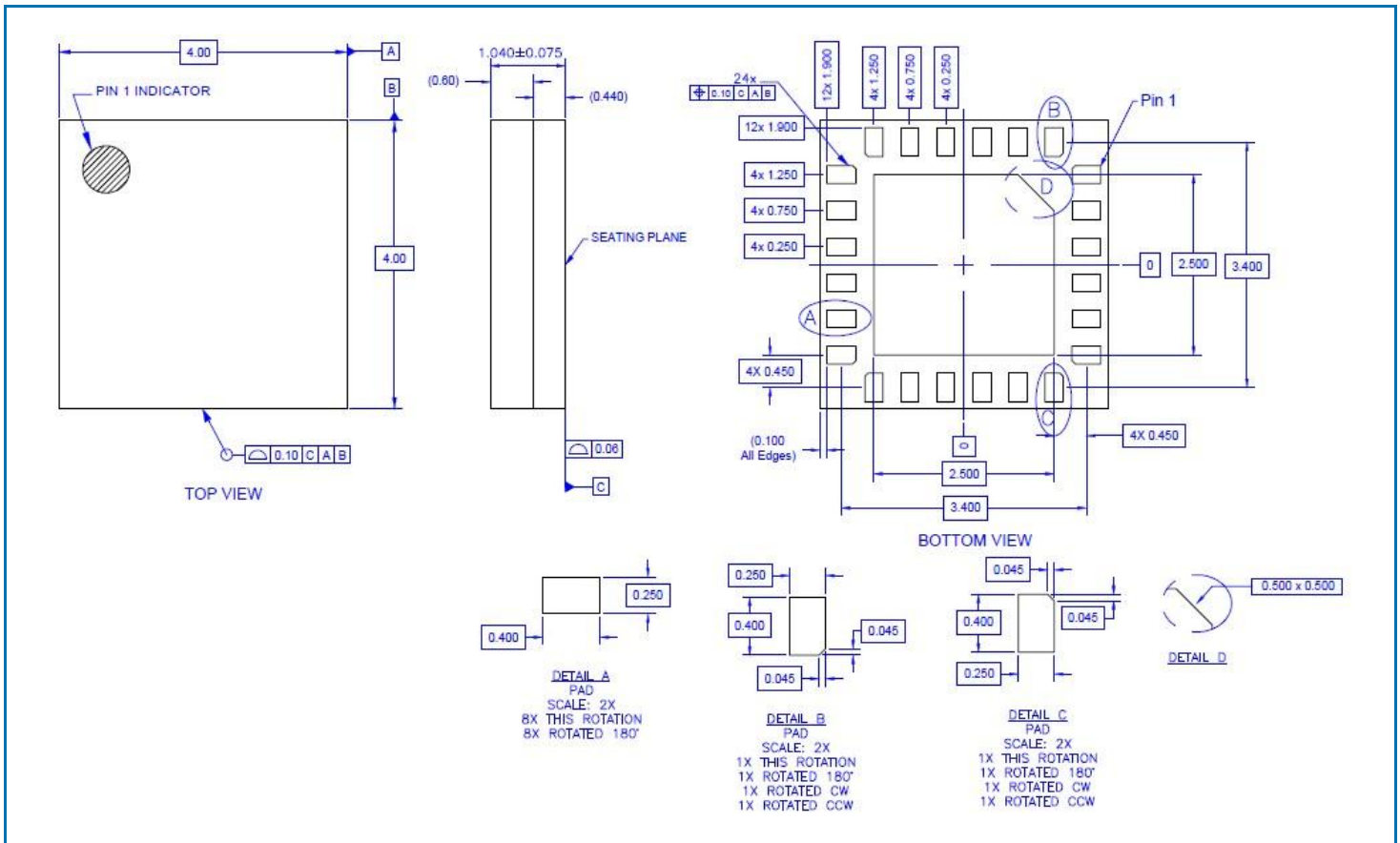

Stencil Drawing (Dimensions in millimeters)

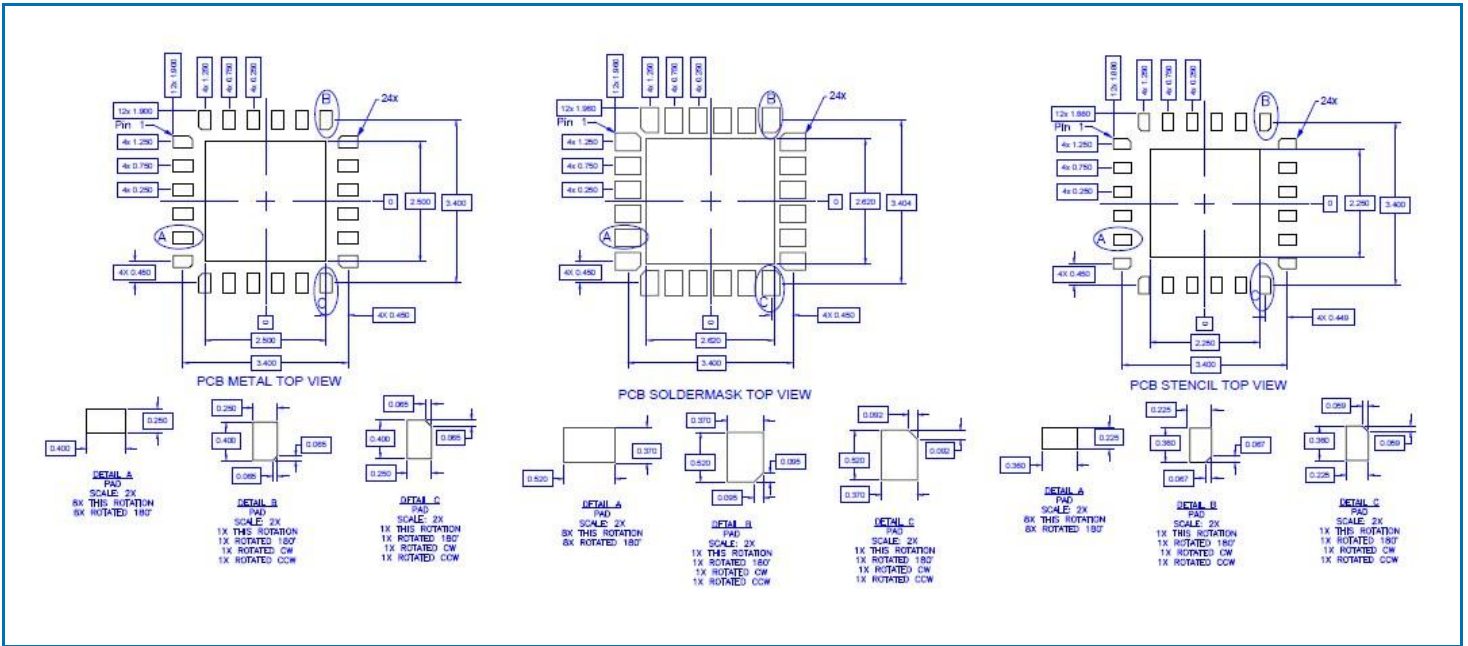

Pin Out

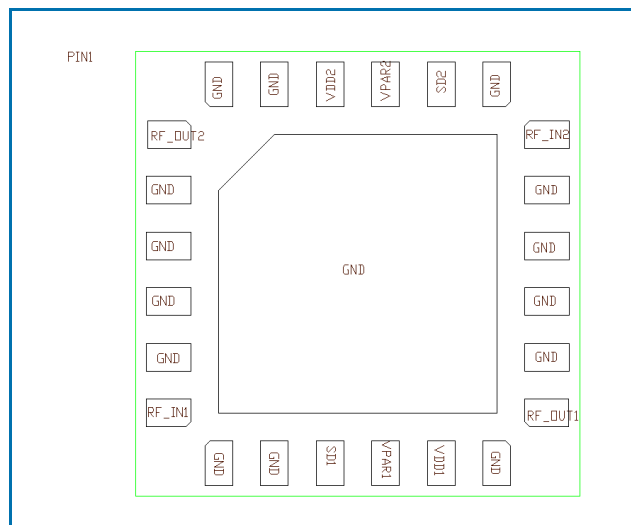

Branding Diagram

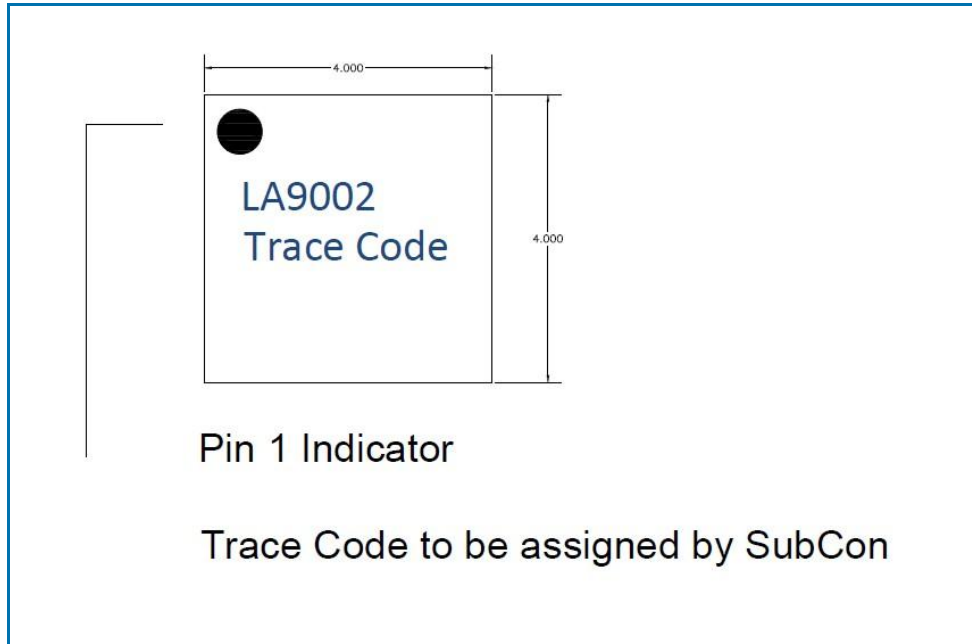

Данный компонент на территории Российской Федерации

Вы можете приобрести в компании MosChip.

Для оперативного оформления запроса Вам необходимо перейти по данной ссылке:

<http://moschip.ru/get-element>

Вы можете разместить у нас заказ для любого Вашего проекта, будь то серийное производство или разработка единичного прибора.

В нашем ассортименте представлены ведущие мировые производители активных и пассивных электронных компонентов.

Нашей специализацией является поставка электронной компонентной базы двойного назначения, продукции таких производителей как XILINX, Intel (ex.ALTERA), Vicor, Microchip, Texas Instruments, Analog Devices, Mini-Circuits, Amphenol, Glenair.

Сотрудничество с глобальными дистрибьюторами электронных компонентов, предоставляет возможность заказывать и получать с международных складов практически любой перечень компонентов в оптимальные для Вас сроки.

На всех этапах разработки и производства наши партнеры могут получить квалифицированную поддержку опытных инженеров.

Система менеджмента качества компании отвечает требованиям в соответствии с ГОСТ Р ИСО 9001, ГОСТ РВ 0015-002 и ЭС РД 009

Офис по работе с юридическими лицами:

105318, г.Москва, ул.Щербаковская д.3, офис 1107, 1118, ДЦ «Щербаковский»

Телефон: +7 495 668-12-70 (многоканальный)

Факс: +7 495 668-12-70 (доб.304)

E-mail: info@moschip.ru

Skype отдела продаж:

moschip.ru

moschip.ru_4

moschip.ru_6

moschip.ru_9