

nRF24LE1

Ultra-low Power Wireless System On-Chip Solution

Product Specification v1.6

Key Features

- nRF24L01+ 2.4 GHz transceiver (250 kbps, 1 Mbps and 2 Mbps air data rates)
- Fast microcontroller (8051 compatible)
- 16 kB program memory (on-chip Flash)
- 1 kB data memory (on-chip RAM)
- 1 kB NV data memory
- 512 bytes NV data memory (extended endurance)
- AES encryption HW accelerator
- 16-32bit multiplication/division co-processor (MDU)
- 6-12 bit ADC
- High flexibility IOs
- Serves a set of power modes from ultra low power to a power efficient active mode
- Several versions in various QFN packages:
 - ▶ 4×4mm QFN24
 - ▶ 5×5mm QFN32
 - ▶ 7×7mm QFN48
- Support for HW debugger
- HW support for firmware upgrade

Applications

- Computer peripherals
 - ▶ Mouse
 - ▶ Keyboard
 - ▶ Remote control
 - ▶ Gaming
- Advanced remote controls
 - ▶ Audio/Video
 - ▶ Entertainment centers
 - ▶ Home appliances
- Goods tracking and monitoring:
 - ▶ Active RFID
 - ▶ Sensor networks
- Security systems
 - ▶ Payment
 - ▶ Alarm
 - ▶ Access control
- Health, wellness and sports
 - ▶ Watches
 - ▶ Mini computers
 - ▶ Sensors
- Remote control toys

Liability disclaimer

Nordic Semiconductor ASA reserves the right to make changes without further notice to the product to improve reliability, function or design. Nordic Semiconductor ASA does not assume any liability arising out of the application or use of any product or circuits described herein.

All application information is advisory and does not form part of the specification.

Limiting values

Stress above one or more of the limiting values may cause permanent damage to the device. These are stress ratings only and operation of the device at these or at any other conditions above those given in the specifications are not implied. Exposure to limiting values for extended periods may affect device reliability.

Life support applications

These products are not designed for use in life support appliances, devices, or systems where malfunction of these products can reasonably be expected to result in personal injury. Nordic Semiconductor ASA customers using or selling these products for use in such applications do so at their own risk and agree to fully indemnify Nordic Semiconductor ASA for any damages resulting from such improper use or sale.

Data sheet status	
Objective product specification	This product specification contains target specifications for product development.
Preliminary product specification	This product specification contains preliminary data; supplementary data may be published from Nordic Semiconductor ASA later.
Product specification	This product specification contains final product specifications. Nordic Semiconductor ASA reserves the right to make changes at any time without notice in order to improve design and supply the best possible product.

Contact details

For your nearest dealer, please see www.nordicsemi.com

Main office:

Otto Nielsens veg 12
 7004 Trondheim
 Norway
 Phone: +47 72 89 89 00
 Fax: +47 72 89 89 89



Revision History

Date	Version	Description
March 2009	1.2	Updated Figure 33 , Figure 34 , and Table 35 .
September 2009	1.3	Added Table 93 . Updated BOM, Table 28 , Table 29 , Table 34 , Table 46 , Table 53 , Table 61 , Table 87 , Table 101 , Table 113 , Table 115 , sections 6.3.4.1 , 9.1 , 9.3 , 13.3.3 , 29.1.2 , 29.2.2 , 29.3.2 and 30.1 . Simplified way of writing binary numbers and denoting register bits.
April 2010	1.4	Updated Figure 9 , Figure 10 , Figure 30 , Note: on page 87 , Figure 46 , Figure 51 , and Figure 52 . Updated section 2.1 , section 12.3 , section 13.3.1 , Table 14 , Table 15 , Table 27 , Table 58 , Table 111 , Table 114 , and Table 115 . Updated BOM information in chapter 29 .
July 2010	1.5	Updated 6.3.5.1 on page 77 , Table 57. on page 109 , Table 58. on page 111 , Table 88. on page 150 , and Human Body Model Class in chapter 24 on page 176 .
August 2010	1.6	Added RoHS statement and updated Table 88. on page 150 .

RoHS statement

Nordic Semiconductor's products meet the requirements of Directive 2002/95/EC of the European Parliament and of the Council on the Restriction of Hazardous Substances (RoHS). Complete hazardous substance reports as well as material composition reports for all active Nordic products can be found on our web site www.nordicsemi.com.

Contents

1	Introduction	10
1.1	Prerequisites	10
1.2	Writing conventions	10
2	Product overview	11
2.1	Features	11
2.2	Block diagram	13
2.3	Pin assignments	14
2.3.1	24-pin 4x4 QFN-package variant	14
2.3.2	32-pin 5x5 QFN-package variant	14
2.3.3	48-pin 7x7 QFN-package variant	15
2.4	Pin functions	15
3	RF transceiver	16
3.1	Features	16
3.2	Block diagram	17
3.3	Functional description	17
3.3.1	Operational Modes	17
3.3.2	Air data rate	21
3.3.3	RF channel frequency	21
3.3.4	Received Power Detector measurements	21
3.3.5	PA control	21
3.3.6	RX/TX control	22
3.4	Enhanced ShockBurst™	22
3.4.1	Features	22
3.4.2	Enhanced ShockBurst™ overview	22
3.4.3	Enhanced Shockburst™ packet format	23
3.4.4	Automatic packet assembly	26
3.4.5	Automatic packet disassembly	27
3.4.6	Automatic packet transaction handling	28
3.4.7	Enhanced ShockBurst flowcharts	30
3.4.8	MultiCeiver™	33
3.4.9	Enhanced ShockBurst™ timing	35
3.4.10	Enhanced ShockBurst™ transaction diagram	38
3.4.11	Compatibility with ShockBurst™	42
3.5	Data and control interface	43
3.5.1	SFR registers	43
3.5.2	SPI operation	44
3.5.3	Data FIFO	46
3.5.4	Interrupt	47
3.6	Register map	48
3.6.1	Register map table	48
4	MCU	54
4.1	Block diagram	55
4.2	Features	55
4.3	Functional description	56

4.3.1	Arithmetic Logic Unit (ALU)	56
4.3.2	Instruction set summary	56
4.3.3	Opcode map	60
5	Memory and I/O organization	62
5.1	PDATA memory addressing	63
5.2	MCU Special Function Registers	63
5.2.1	Accumulator - ACC	63
5.2.2	B Register – B	63
5.2.3	Program Status Word Register - PSW	64
5.2.4	Stack Pointer – SP	64
5.2.5	Data Pointer – DPH, DPL	64
5.2.6	Data Pointer 1 – DPH1, DPL1	65
5.2.7	Data Pointer Select Register – DPS	65
5.2.8	PCON register	65
5.2.9	Special Function Register Map	66
5.2.10	Special Function Registers reset values	67
6	Flash memory	70
6.1	Features	70
6.2	Block diagram	70
6.3	Functional description	71
6.3.1	Using the NV data memory	71
6.3.2	Flash memory configuration	71
6.3.3	Brown-out	76
6.3.4	Flash programming from the MCU	77
6.3.5	Flash programming through SPI	77
6.3.6	Hardware support for firmware upgrade	81
7	Random Access memory (RAM)	84
7.1	SRAM configuration	84
8	Timers/counters	86
8.1	Features	86
8.2	Block diagram	86
8.3	Functional description	87
8.3.1	Timer 0 and Timer 1	87
8.3.2	Timer 2	89
8.4	SFR registers	91
8.4.1	Timer/Counter control register – TCON	91
8.4.2	Timer mode register - TMOD	92
8.4.3	Timer 0 – TH0, TL0	92
8.4.4	Timer 1 – TH1, TL1	92
8.4.5	Timer 2 control register – T2CON	93
8.4.6	Timer 2 – TH2, TL2	93
8.4.7	Compare/Capture enable register – CCEN	94
8.4.8	Capture registers – CC1, CC2, CC3	94
8.4.9	Compare/Reload/Capture register – CRCH, CRCL	95
8.5	Real Time Clock - RTC	95
8.5.1	Features	95

8.5.2	Functional description of SFR registers	95
9	Interrupts	99
9.1	Features	99
9.2	Block diagram	99
9.3	Functional description	100
9.4	SFR registers	100
9.4.1	Interrupt Enable 0 Register – IEN0.....	101
9.4.2	Interrupt Enable 1 Register – IEN1	101
9.4.3	Interrupt Priority Registers – IP0, IP1	101
9.4.4	Interrupt Request Control Registers – IRCON	102
10	Watchdog.....	103
10.1	Features	103
10.2	Block diagram	103
10.3	Functional description	103
11	Power and clock management.....	105
11.1	Block diagram	105
11.2	Modes of operation	105
11.3	Functional description	110
11.3.1	Clock control.....	110
11.3.2	Power down control – PWRDWN	113
11.3.3	Operational mode control - OPMCON.....	114
11.3.4	Reset result – RSTREAS	114
11.3.5	Wakeup configuration register – WUCON.....	115
11.3.6	Pin wakeup configuration	115
12	Power supply supervisor	117
12.1	Features	117
12.2	Block diagram	117
12.3	Functional description	117
12.3.1	Power-on reset	117
12.3.2	Brown-out reset	118
12.3.3	Power-fail comparator	118
12.4	SFR registers	119
13	On-chip oscillators.....	120
13.1	Features	120
13.2	Block diagrams.....	120
13.3	Functional description	121
13.3.1	16 MHz crystal oscillator.....	121
13.3.2	16 MHz RC oscillator	122
13.3.3	External 16 MHz clock.....	122
13.3.4	32.768 kHz crystal oscillator	122
13.3.5	32.768 kHz RC oscillator	123
13.3.6	Synthesized 32.768 kHz clock.....	123
13.3.7	External 32.768 kHz clock	123
14	MDU – Multiply Divide Unit.....	124
14.1	Features	124
14.2	Block diagram	124

14.3	Functional description	124
14.4	SFR registers	124
14.4.1	Loading the MDx registers.....	125
14.4.2	Executing calculation	126
14.4.3	Reading the result from the MDx registers	126
14.4.4	Normalizing.....	126
14.4.5	Shifting.....	126
14.4.6	The mdef flag.....	126
14.4.7	The mdov flag.....	127
15	Encryption/decryption accelerator.....	128
15.1	Features	128
15.2	Block diagram	128
15.3	Functional description	128
16	Random number generator	130
16.1	Features	130
16.2	Block diagram	130
16.3	Functional description	130
16.4	SFR registers	131
17	General purpose IO port and pin assignments	132
17.1	Block diagram	132
17.2	Functional description	133
17.2.1	General purpose IO pin functionality	133
17.2.2	PortCrossbar functionality	134
17.3	IO pin maps.....	135
17.3.1	Pin assignments in package 24 pin 4x4 mm	136
17.3.2	Pin assignments in package 32 pin 5x5 mm	137
17.3.3	Pin assignments in package 48 pin 7x7 mm	138
17.3.4	Programmable registers	140
18	SPI	147
18.1	Features	147
18.2	Block diagram	147
18.3	Functional description	148
18.3.1	SPI master.....	148
18.3.2	SPI slave	150
18.3.3	Slave SPI timing	151
19	Serial port (UART)	155
19.1	Features	155
19.2	Block diagram	155
19.3	Functional description	155
19.3.1	Serial port 0 control register – S0CON	156
19.3.2	Serial port 0 data buffer – S0BUF	157
19.3.3	Serial port 0 reload register – S0RELH, S0RELL.....	157
19.3.4	Serial port 0 baud rate select register - ADCON	158
20	2-Wire	159
20.1	Features	159
20.2	Functional description	159

20.2.1	Recommended use	159
20.2.2	Master transmitter/receiver	159
20.2.3	Slave transmitter/receiver	160
20.3	SFR registers	162
21	ADC	165
21.1	Features	165
21.2	Block diagram	165
21.3	Functional description	165
21.3.1	Activation	165
21.3.2	Input selection	166
21.3.3	Reference selection	166
21.3.4	Resolution.....	166
21.3.5	Conversion modes.....	166
21.3.6	Output data coding	167
21.3.7	Driving the analog input.....	168
21.3.8	SFR registers.....	169
22	Analog comparator	171
22.1	Features	171
22.2	Block diagram	171
22.3	Functional description	171
22.3.1	Activation	171
22.3.2	Input selection	171
22.3.3	Reference selection	172
22.3.4	Output polarity	172
22.3.5	Input voltage range.....	172
22.3.6	Configuration examples.....	172
22.3.7	Driving the analog input.....	172
22.3.8	SFR registers.....	173
23	PWM	174
23.1	Features	174
23.2	Block diagram	174
23.3	Functional description	174
24	Absolute maximum ratings	176
25	Operating condition	177
26	Electrical specifications	178
26.1	Power consumption.....	183
27	HW debugger support	185
27.1	Features	185
27.2	Functional description	185
28	Mechanical specifications	186
29	Reference circuits	188
29.1	Q48 application example.....	188
29.1.1	Schematic.....	188
29.1.2	Layout.....	189
29.1.3	Bill Of Materials (BOM).....	189
29.2	Q32 application example.....	190

29.2.1	Schematic.....	190
29.2.2	Layout.....	191
29.2.3	Bill Of Materials (BOM).....	191
29.3	Q24 application example.....	192
29.3.1	Schematic.....	192
29.3.2	Layout.....	193
29.3.3	Bill Of Materials (BOM).....	193
30	Ordering information	194
30.1	Package marking	194
30.1.1	Abbreviations.....	194
30.2	Product options	195
30.2.1	RF silicon.....	195
30.2.2	Development tools.....	195
31	Glossary.....	196

1 Introduction

The nRF24LE1 is a member of the low-cost, high-performance family of intelligent 2.4 GHz RF transceivers with embedded microcontrollers. The nRF24LE1 is optimized to provide a single chip solution for ULP wireless applications. The combination of processing power, memory, low power oscillators, real-time counter, AES encryption accelerator, random generator and a range of power saving modes provides an ideal platform for implementation of RF protocols. Benefits of using nRF24LE1 include tighter protocol timing, security, lower power consumption and improved co-existence performance. For the application layer the nRF24LE1 offers a rich set of peripherals including: SPI, 2-wire, UART, 6 to 12 bit ADC, PWM and an ultra low power analog comparator for voltage level system wake-up.

The nRF24LE1 comes in three different package variants:

- An ultra compact 4×4mm 24 pin QFN (7 generic I/O pins)
- A compact 5×5mm 32 pin QFN (15 generic I/O pins)
- A 7×7mm 48 pin QFN (31 generic I/O pins)

The 4×4mm 24 pin QFN is ideal for low I/O count applications where small size is key. Examples include wearable sports sensors and watches. The 5×5mm 32 pin QFN is ideal for medium I/O count applications such as wireless mouse, remote controls and toys. The 7×7mm 48 pin QFN is designed for high I/O count products like wireless keyboards.

1.1 Prerequisites

In order to fully understand the product specification, a good knowledge of electronics and software engineering is necessary.

1.2 Writing conventions

This product specification follows a set of typographic rules that makes the document consistent and easy to read. The following writing conventions are used:

- Commands, bit state conditions, and register names are written in *Courier*.
- Pin names and pin signal conditions are written in *Courier bold*.
- Cross references are [underlined and highlighted in blue](#).

2 Product overview

2.1 Features

Features of the nRF24LE1 include:

- Fast 8-bit microcontroller:
 - Intel MCS 51 compliant instruction set
 - Reduced instruction cycle time, up to 12 times compared to legacy 8051
 - 32 bit multiplication – division unit
- Memory:
 - Program memory: 16 kB of Flash memory with security features (up to 1k erase/ write cycles)
 - Data memory: 1 kB of on-chip RAM memory
 - Non-volatile data memory: 1 kB
 - Non-volatile data memory extended endurance: 512 bytes (up to 20k erase/ write cycles)
- A number of on-chip hardware resources are available through programmable multi-purpose input/output pins (7-31 pins dependent on package variant):
 - GPIO
 - SPI master
 - SPI slave
 - 2-Wire master/ slave
 - Full duplex serial port
 - PWM
 - ADC
 - Analog comparator
 - External interrupts
 - Timer inputs
 - 32.768 kHz crystal oscillator
 - Debug interface
- High performance 2.4 GHz RF-transceiver
 - True single chip GFSK transceiver
 - Enhanced ShockBurst™ link layer support in HW:
 - Packet assembly/disassembly
 - Address and CRC computation
 - Auto ACK and retransmit
 - On the air data rate 250 kbps, 1 Mbps or 2 Mbps
 - Digital interface (SPI) speed 0-8 Mbps
 - 125 RF channel option, with 79 (2.402 GHz-2.480 GHz) channels within 2.400 - 2.4835 GHz
 - Short switching time enable frequency hopping
 - Fully RF compatible with nRF24LXX
 - RF compatible with nRF2401A, nRF2402, nRF24E1, nRF24E2 in 250 kbps and 1 Mbps mode
- A/D converter:
 - 6, 8, 10 or 12 bit resolution
 - 14 input channels
 - Single ended or differential input
 - Full-scale range set by internal reference, external reference or VDD
 - Single step mode with conversion time down to 3 μs
 - Continuous mode with 2, 4, 8 or 16 kbps sampling rate
 - Low current consumption; only 0.1mA at 2 ksps
 - Mode for measuring supply voltage

- Analog comparator:
 - ▶ Used as wakeup source
 - ▶ Low current consumption (0.75µA typical)
 - ▶ Differential or single-ended input
 - ▶ Single-ended threshold programmable to 25%, 50%, 75% or 100% of VDD or an arbitrary reference voltage from pin
 - ▶ 14-channel input multiplexer
 - ▶ Rail-to-rail input voltage range
 - ▶ Programmable output polarity
- Encryption/decryption accelerator
 - ▶ Utilize time and power effective AES firmware
- Random number generator:
 - ▶ Non-deterministic architecture based on thermal noise
 - ▶ No seed value required
 - ▶ Non-repeating sequence
 - ▶ Corrector algorithm ensures uniform statistical distribution
 - ▶ Data rate up to 10 kB per second
 - ▶ Operational while the processor is in standby
- System reset and power supply monitoring:
 - ▶ On-chip power-on and brown-out reset
 - ▶ Watchdog timer reset
 - ▶ Reset from pin
 - ▶ Power-fail comparator with programmable threshold and interrupt to MCU
- On-chip timers:
 - ▶ Three 16-bit timers/counters operating at the system clock (sources from the 16 MHz on-chip oscillators)
 - ▶ One 16-bit timer/counter operating at the low frequency clock (32.768 kHz)
- On-chip oscillators:
 - ▶ 16 MHz crystal oscillator XOSC16M
 - ▶ 16 MHz RC-oscillator RCOSC16M
 - ▶ 32.768 kHz crystal oscillator XOSC32K
 - ▶ 32.768 kHz RC-oscillator RCOSC32K
- Power management function:
 - ▶ Low power design supporting fully static stop/ standby
 - ▶ Programmable MCU clock frequency from 125 kHz to 16 MHz
 - ▶ On chip voltage regulators supporting low power mode
 - ▶ Watchdog and wakeup functionality running in low power mode
- On chip support for FS2 or nRFprobe™ HW debug
- Complete firmware platform available:
 - ▶ Hardware abstraction layer (HAL) Functions
 - ▶ Library functions
 - ▶ Gazell Wireless protocol
 - ▶ Application examples

2.2 Block diagram

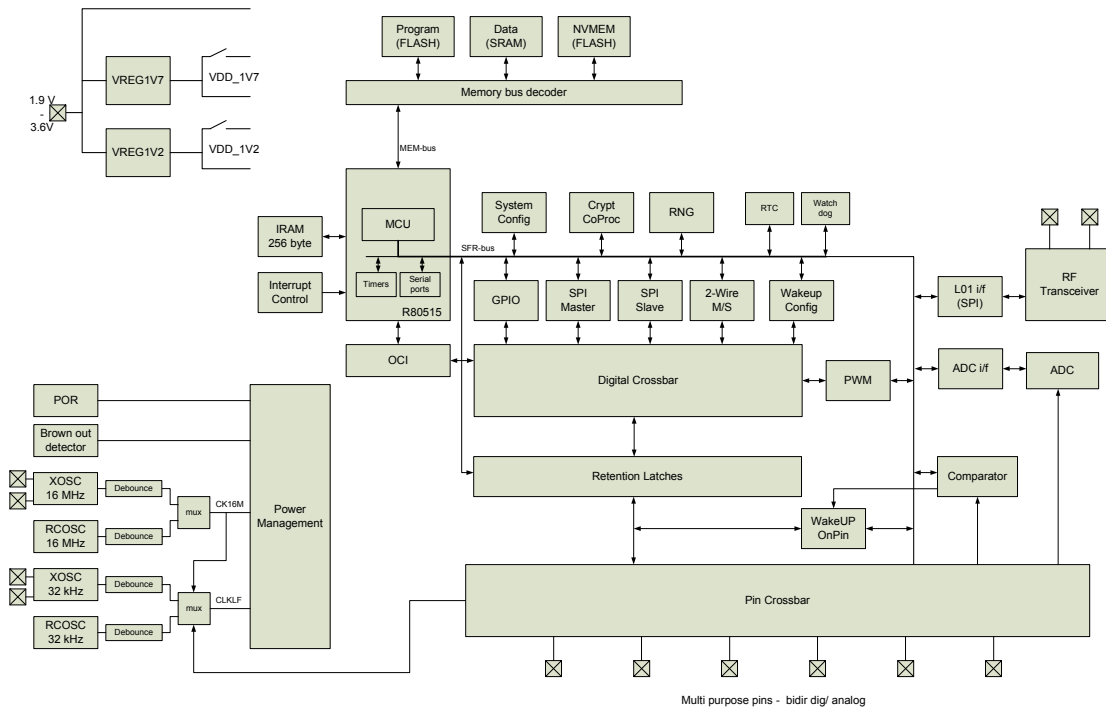

Figure 1. nRF24LE1 block diagram

To find more information on the blocks, see [Table 1](#), below:

Name	Reference
Memory (Program, Data, NVMEM)	Chapter 5 on page 62
Power management	Chapter 11 on page 105
RF Transceiver	Chapter 3 on page 16
2-Wire	Chapter 20 on page 159
SPI (Master and Slave)	Chapter 18 on page 147
GPIO	Chapter 17 on page 132
PWM	Chapter 23 on page 174
Watchdog	Chapter 10 on page 103

Table 1. Block diagram cross references

2.3 Pin assignments

2.3.1 24-pin 4x4 QFN-package variant

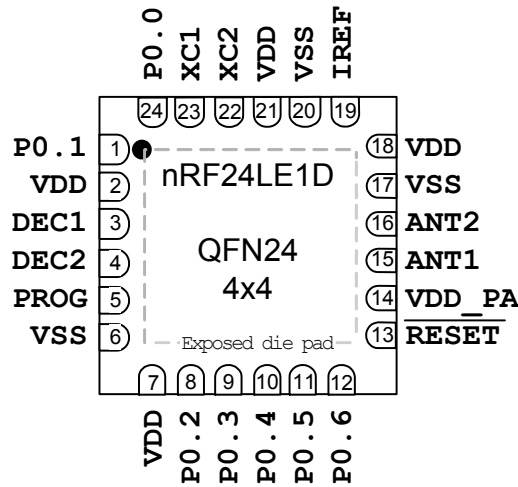

Figure 2. nRF24LE1D pin assignment (top view) for a QFN24 4x4 mm package

2.3.2 32-pin 5x5 QFN-package variant

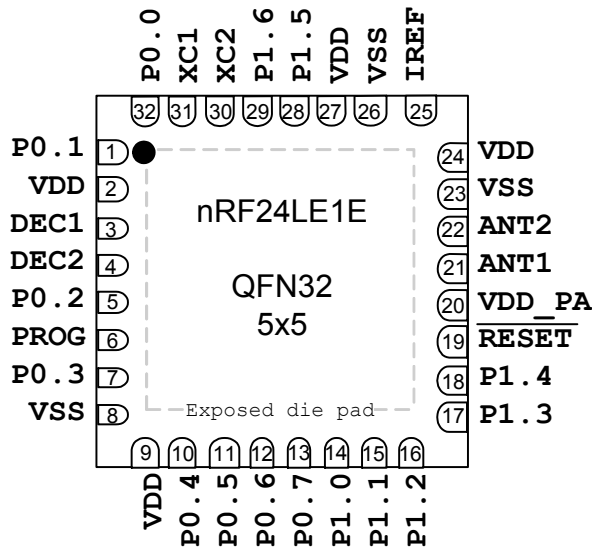

Figure 3. nRF24LE1E pin assignment (top view) for a QFN32 5x5 mm package

2.3.3 48-pin 7x7 QFN-package variant

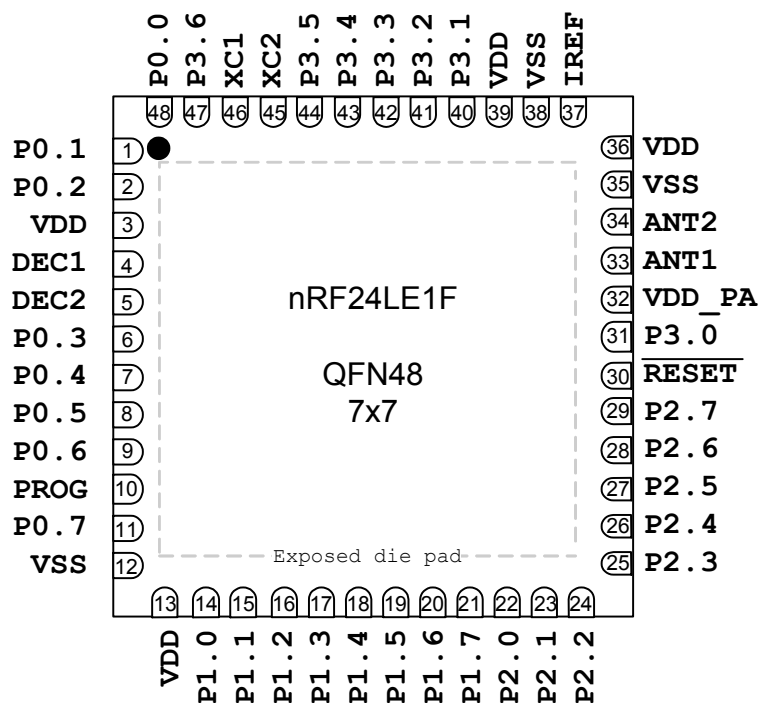

Figure 4. nRF24LE1F pin assignment (top view) for a QFN48 7x7 mm package

2.4 Pin functions

Name	Type	Description
VDD	Power	Power supply (+1.9V to +3.6V DC)
VSS	Power	Ground (0V)
DEC1 DEC2	Power	Power supply outputs for de-coupling purposes (100nF for DEC1, 33nF for DEC2)
P0.0 – P3.6	Digital or analog I/O	General purpose I/O pins. Number of I/O available depends on package type.
PROG	Digital Input	Input to enable flash programming
RESET	Digital Input	Reset for microcontroller, active low
IREF	Analog Input	Device reference current output. To be connected to reference resistor on PCB.
VDD_PA	Power Output	Power supply output (+1.8V) for on-chip RF Power amplifier
ANT1, ANT2	RF	Differential antenna connection (TX and RX)
XC1, XC2	Analog Input	Crystal connection for 16M crystal
Exposed die pad	Power/heat relief	For the nRF24LE1 QFN48 7x7mm and QFN32 5x5mm connect the die pad to GND. For nRF24LE1 QFN24 4x4mm do not connect the die pad to GND.

Table 2. nRF24LE1 pin functions

3 RF transceiver

The nRF24LE1 uses the same 2.4 GHz GFSK RF transceiver with embedded protocol engine (Enhanced ShockBurst™) that is found in the nRF24L01+ single chip RF transceiver. The RF transceiver is designed for operation in the world wide ISM frequency band at 2.400 - 2.4835 GHz and is very well suited for ultra low power wireless applications.

The RF transceiver module is configured and operated through the RF transceiver map. This register map is accessed by the MCU through a dedicated on-chip Serial Peripheral interface (SPI) and is available in all power modes of the RF transceiver module.

The embedded protocol engine (Enhanced ShockBurst™) enables data packet communication and supports various modes from manual operation to advanced autonomous protocol operation. Data FIFOs in the RF transceiver module ensure a smooth data flow between the RF transceiver module and the nRF24LE1 MCU.

The rest of this chapter is written in the context of the RF transceiver module as the core and the rest of the nRF24LE1 as external circuitry to this module.

3.1 Features

Features of the RF transceiver include:

- General
 - Worldwide 2.4 GHz ISM band operation
 - Common antenna interface in transmit and receive
 - GFSK modulation
 - 250kbps, 1 and 2Mbps on air data rate
- Transmitter
 - Programmable output power: 0, -6, -12 or -18dBm
 - 11.1mA at 0dBm output power
- Receiver
 - Integrated channel filters
 - 13.3mA at 2Mbps
 - -82dBm sensitivity at 2 Mbps
 - -85dBm sensitivity at 1 Mbps
 - -94dBm sensitivity at 250 kbps
- RF Synthesizer
 - Fully integrated synthesizer
 - 1 MHz frequency programming resolution
 - Accepts low cost ± 60 ppm 16 MHz crystal
 - 1 MHz non-overlapping channel spacing at 1 Mbps
 - 2 MHz non-overlapping channel spacing at 2 Mbps
- Enhanced ShockBurst™
 - 1 to 32 bytes dynamic payload length
 - Automatic packet handling (assembly/disassembly)
 - Automatic packet transaction handling (auto ACK, auto retransmit)
- 6 data pipe MultiCeiver™ for 6:1 star networks

3.2 Block diagram

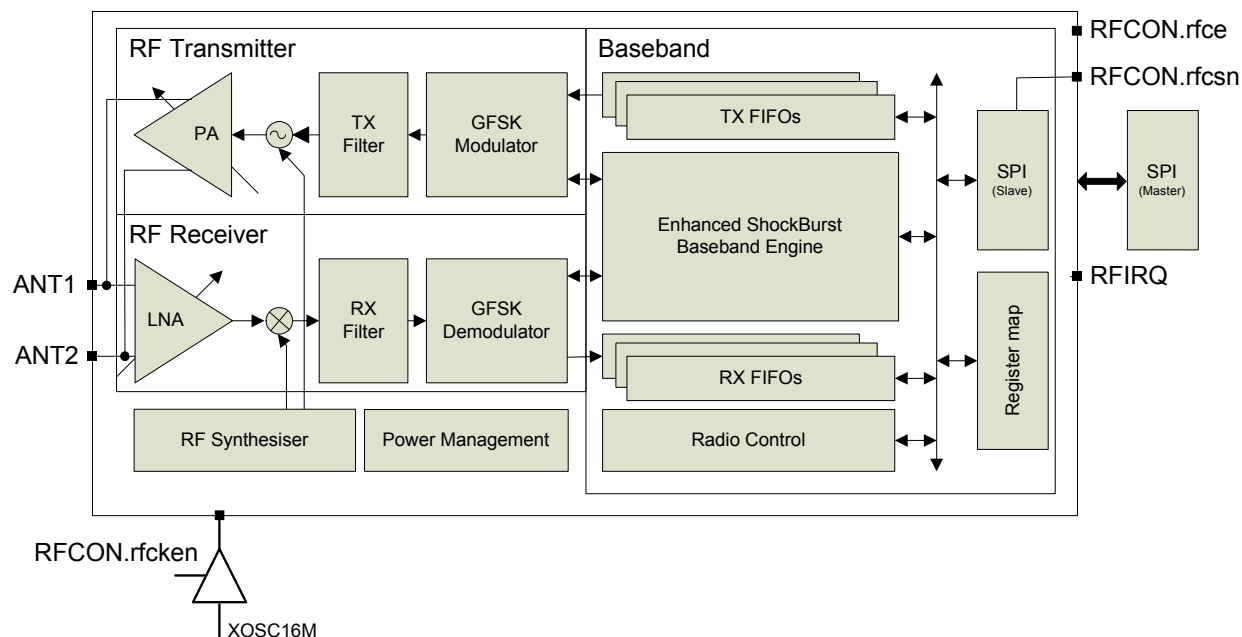

Figure 5. RF transceiver block diagram

3.3 Functional description

This section describes the different operating modes of the RF transceiver and the parameters used to control it.

The RF transceiver module has a built-in state machine that controls the transitions between the different operating modes. The state machine is controlled by SFR register `RFCON` and RF transceiver register `CONFIG`, see [section 3.5](#) for details.

3.3.1 Operational Modes

You can configure the RF transceiver to power down, standby, RX and TX mode. This section describes these modes in detail.

3.3.1.1 State diagram

The state diagram ([Figure 6.](#)) shows the operating modes of the RF transceiver and how they function. At the end of the reset sequence the RF transceiver enters Power Down mode. When the RF transceiver enters Power Down mode the MCU can still control the module through the SPI and the `rfcsn` bit in the `RFCON` register.

There are three types of distinct states highlighted in the state diagram:

- **Recommended operating mode:** is a recommended state used during normal operation.
- **Possible operating mode:** is a possible operating state, but is not used during normal operation.
- **Transition state:** is a time limited state used during start up of the oscillator and settling of the PLL.

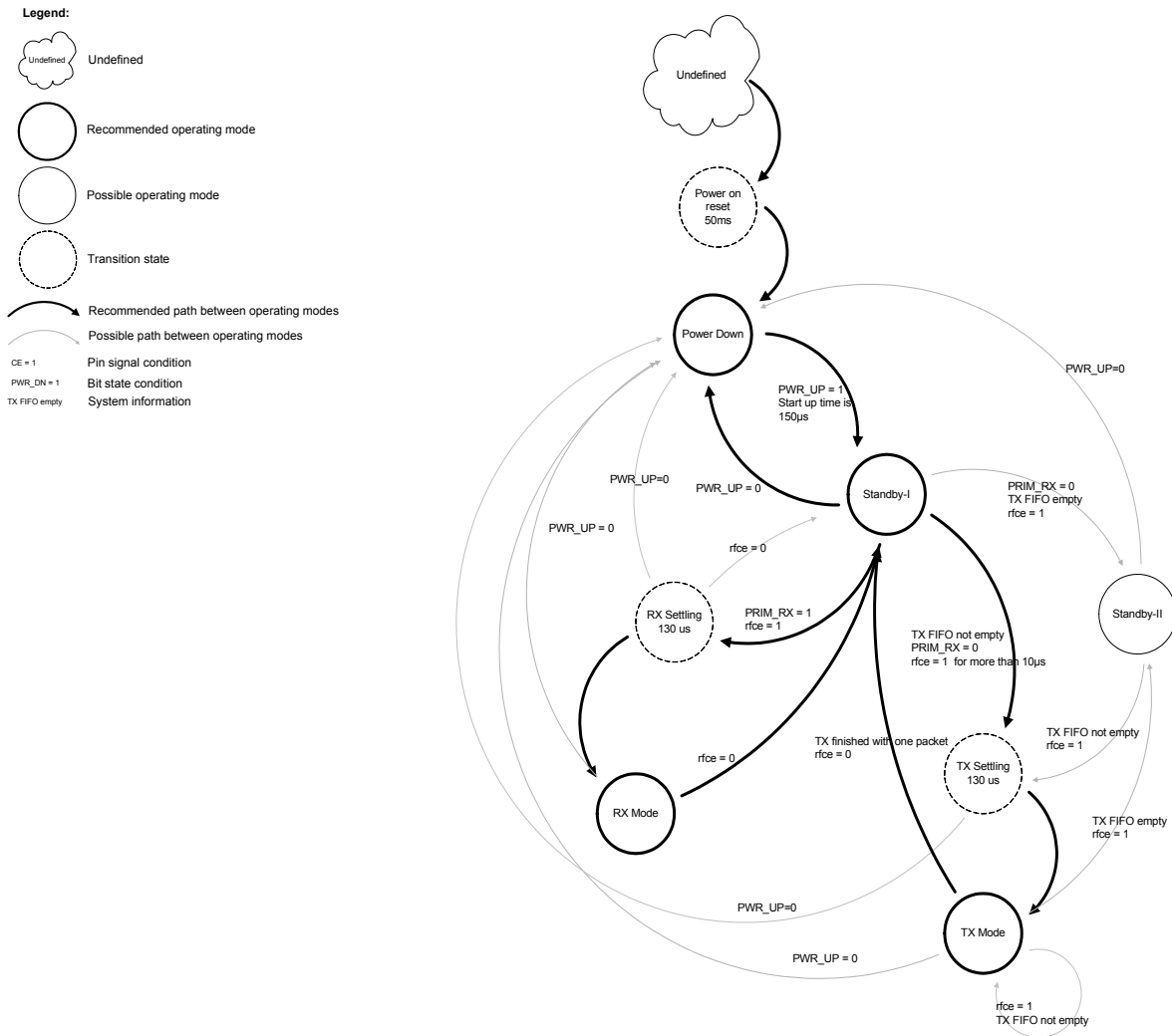

Figure 6. Radio control state diagram

3.3.1.2 Power down mode

In power down mode the RF transceiver is disabled with minimal current consumption. All the register values available from the SPI are maintained and the SPI can be activated. For start up times see [Table 4. on page 20](#). Power down mode is entered by setting the `PWR_UP` bit in the `CONFIG` register low.

3.3.1.3 Standby modes

Standby-I mode

By setting the `PWR_UP` bit in the `CONFIG` register to 1, the RF transceiver enters standby-I mode. Standby-I mode is used to minimize average current consumption while maintaining short start up times. Change to the active mode only happens if the `rfce` bit is enabled and when it is not enabled, the RF transceiver returns to standby-I mode from both the TX and RX modes.

Standby-II mode

In standby-II mode extra clock buffers are active and more current is used compared to standby-I mode. The RF transceiver enters standby-II mode if the `rfce` bit is held high on a PTX operation with an empty TX FIFO. If a new packet is downloaded to the TX FIFO, the PLL immediately starts and the packet is transmitted after the normal PLL settling delay (130µs).

The register values are maintained and the SPI can be activated during both standby modes. For start up times see [Table 4. on page 20](#).

3.3.1.4 RX mode

The RX mode is an active mode where the RF transceiver is used as a receiver. To enter this mode, the RF transceiver must have the `PWR_UP` bit, `PRIM_RX` bit and the `rfce` bit is set high.

In RX mode the receiver demodulates the signals from the RF channel, constantly presenting the demodulated data to the baseband protocol engine. The baseband protocol engine constantly searches for a valid packet. If a valid packet is found (by a matching address and a valid CRC) the payload of the packet is presented in a vacant slot in the RX FIFOs. If the RX FIFOs are full, the received packet is discarded.

The RF transceiver remains in RX mode until the MCU configures it to standby-I mode or power down mode. However, if the automatic protocol features (Enhanced ShockBurst™) in the baseband protocol engine are enabled, the RF transceiver can enter other modes in order to execute the protocol.

In RX mode a Received Power Detector (RPD) signal is available. The RPD is a signal that is set high when a RF signal higher than -64 dBm is detected inside the receiving frequency channel. The internal RPD signal is filtered before presented to the RPD register. The RF signal must be present for at least 40µs before the RPD is set high. How to use the RPD is described in [Section 3.3.4 on page 21](#).

3.3.1.5 TX mode

The TX mode is an active mode for transmitting packets. To enter this mode, the RF transceiver must have the `PWR_UP` bit set high, `PRIM_RX` bit set low, a payload in the TX FIFO and a high pulse on the `rfce` bit for more than 10 µs.

The RF transceiver stays in TX mode until it finishes transmitting a packet. If `rfce` = 0, RF transceiver returns to standby-I mode. If `rfce` = 1, the status of the TX FIFO determines the next action. If the TX FIFO is not empty the RF transceiver remains in TX mode and transmits the next packet. If the TX FIFO is empty the RF transceiver goes into standby-II mode. The RF transceiver transmitter PLL operates in open loop when in TX mode. It is important never to keep the RF transceiver in TX mode for more than 4ms at a time. If the Enhanced ShockBurst™ features are enabled, RF transceiver is never in TX mode longer than 4 ms.

3.3.1.6 Operational modes configuration

The following table ([Table 3.](#)) describes how to configure the operational modes.

Mode	PWR_UP register	PRIM_RX register	rfce	FIFO state
RX mode	1	1	1	-
TX mode	1	0	1	Data in TX FIFO. Will empty all levels in TX FIFO ^a .
TX mode	1	0	Minimum 10µs high pulse	Data in TX FIFO. Will empty one level in TX FIFO ^b .
Standby-II	1	0	1	TX FIFO empty
Standby-I	1	-	0	No ongoing packet transmission
Power Down	0	-	-	-

- If the `rfce` bit is held high the TX FIFO is emptied and all necessary ACK and possible retransmits are carried out. The transmission continues as long as the TX FIFO is refilled. If the TX FIFO is empty when the `rfce` bit is still high, the RF transceiver enters standby-II mode. In this mode the transmission of a packet is started as soon as the `rfcsn` is set high after an upload (UL) of a packet to TX FIFO.
- This operating mode pulses the `rfce` bit high for at least 10µs. This allows one packet to transmit. This is the normal operating mode. After the packet is transmitted, the RF transceiver enters standby-I mode.

Table 3. RF transceiver main modes

3.3.1.7 Timing information

The timing information in this section relates to the transitions between modes and the timing for the `rfce` bit. The transition from TX mode to RX mode or vice versa is the same as the transition from the standby modes to TX mode or RX mode (130µs), as described in [Table 4.](#)

Name	RF Transceiver	Max.	Min.	Comments
Tpd2stby	Power Down → Standby mode	1µs ^a		
Tstby2a	Standby modes → TX/RX mode	130µs		
Thce	Minimum <code>rfce</code> high		10µs	
Tpece2csn	Delay from <code>rfce</code> pos. edge to <code>rfcsn</code> low		4µs	

- This presupposes that the XO is running. Please refer to CLKLFCTRL for bit 3 in [Table 59. on page 112.](#)

Table 4. Operational timing of RF transceiver

Note: If `VDD` is turned off, or if the nRF24LE1 enters Deep Sleep or Memory Retention mode, the register values are lost and you must configure the RF transceiver before entering the TX or RX modes.

3.3.2 Air data rate

The air data rate is the modulated signaling rate the RF transceiver uses when transmitting and receiving data. It can be 250 kbps, 1 Mbps or 2 Mbps. Using lower air data rate gives better receiver sensitivity than higher air data rate. But, high air data rate gives lower average current consumption and reduced probability of on-air collisions.

The air data rate is set by the `RF_DR` bit in the `RF_SETUP` register. A transmitter and a receiver must be programmed with the same air data rate to communicate with each other.

The RF transceiver is fully compatible with nRF24L01. For compatibility with nRF2401A, nRF2402, nRF24E1, and nRF24E2 the air data rate must be set to 250 kbps or 1 Mbps.

3.3.3 RF channel frequency

The RF channel frequency determines the center of the channel used by the RF transceiver. The channel occupies a bandwidth of less than 1 MHz at 250kbps and 1Mbps and a bandwidth of less than 2 MHz at 2Mbps. The RF transceiver can operate on frequencies from 2.400 GHz to 2.525 GHz. The programming resolution of the RF channel frequency setting is 1 MHz.

At 2Mbps the channel occupies a bandwidth wider than the resolution of the RF channel frequency setting. To ensure non-overlapping channels in 2Mbps mode, the channel spacing must be 2 MHz or more. At 1Mbps and 250kbps the channel bandwidth is the same or lower than the resolution of the RF frequency.

The RF channel frequency is set by the `RF_CH` register according to the following formula:

$$F_0 = 2400 + RF_CH \text{ MHz}$$

You must program a transmitter and a receiver with the same RF channel frequency to communicate with each other.

3.3.4 Received Power Detector measurements

Received Power Detector (RPD), located in register 09, bit 0, triggers at received power levels above -64 dBm that are present in the RF channel you receive on. If the received power is less than -64 dBm, RDP = 0.

The RPD can be read out at any time while the RF transceiver is in receive mode. This offers a snapshot of the current received power level in the channel. The RPD is latched whenever a packet is received or when the MCU sets rfcf low.

The status of RPD is correct when RX mode is enabled and after a wait time of $T_{\text{stby2a}} + T_{\text{delay_AGC}} = 130\mu\text{s} + 40\mu\text{s}$. The RX gain varies over temperature which means that the RPD threshold also varies over temperature. The RPD threshold value is reduced by - 5dB at $T = -40^\circ\text{C}$ and increased by + 5dB at 85°C .

3.3.5 PA control

The PA (Power Amplifier) control is used to set the output power from the RF transceiver power amplifier. In TX mode PA control has four programmable steps, see [Table 5. on page 22.](#)

The PA control is set by the `RF_PWR` bits in the `RF_SETUP` register.

SPI RF-SETUP (RF_PWR)	RF output power	DC current consumption
11	0dBm	11.1mA
10	-6dBm	8.8mA
01	-12dBm	7.3mA
00	-18dBm	6.8mA

Conditions: $V_{DD} = 3.0V$, $V_{SS} = 0V$, $T_A = 27^\circ C$, Load impedance = $15\Omega + j88\Omega$.

Table 5. RF output power setting for the RF transceiver

3.3.6 RX/TX control

The RX/TX control is set by `PRIM_RX` bit in the `CONFIG` register and sets the RF transceiver in transmit/receive.

3.4 Enhanced ShockBurst™

Enhanced ShockBurst™ is a packet based data link layer that features automatic packet assembly and timing, automatic acknowledgement and retransmissions of packets. Enhanced ShockBurst™ enables the implementation of ultra low power and high performance communication. The Enhanced ShockBurst™ features enable significant improvements of power efficiency for bi-directional and uni-directional systems, without adding complexity on the host controller side.

3.4.1 Features

The main features of Enhanced ShockBurst™ are:

- 1 to 32 bytes dynamic payload length
- Automatic packet handling
- Auto packet transaction handling
 - Auto Acknowledgement
 - Auto retransmit
- 6 data pipe MultiCeiver™ for 1:6 star networks

3.4.2 Enhanced ShockBurst™ overview

Enhanced ShockBurst™ uses ShockBurst™ for automatic packet handling and timing. During transmit, ShockBurst™ assembles the packet and clocks the bits in the data packet for transmission. During receive, ShockBurst™ constantly searches for a valid address in the demodulated signal. When ShockBurst™ finds a valid address, it processes the rest of the packet and validates it by CRC. If the packet is valid the payload is moved into a vacant slot in the RX FIFOs. All high speed bit handling and timing is controlled by ShockBurst™.

Enhanced ShockBurst™ features automatic packet transaction handling for the easy implementation of a reliable bi-directional data link. An Enhanced ShockBurst™ packet transaction is a packet exchange between two transceivers, with one transceiver acting as the Primary Receiver (PRX) and the other transceiver acting as the Primary Transmitter (PTX). An Enhanced ShockBurst™ packet transaction is always initiated by a packet transmission from the PTX, the transaction is complete when the PTX has received an

acknowledgment packet (ACK packet) from the PRX. The PRX can attach user data to the ACK packet enabling a bi-directional data link.

The automatic packet transaction handling works as follows:

1. You begin the transaction by transmitting a data packet from the PTX to the PRX. Enhanced ShockBurst™ automatically sets the PTX in receive mode to wait for the ACK packet.
2. If the packet is received by the PRX, Enhanced ShockBurst™ automatically assembles and transmits an acknowledgment packet (ACK packet) to the PTX before returning to receive mode.
3. If the PTX does not receive the ACK packet immediately, Enhanced ShockBurst™ automatically retransmits the original data packet after a programmable delay and sets the PTX in receive mode to wait for the ACK packet.

In Enhanced ShockBurst™ it is possible to configure parameters such as the maximum number of retransmits and the delay from one transmission to the next retransmission. All automatic handling is done without the involvement of the MCU.

3.4.3 Enhanced Shockburst™ packet format

The format of the Enhanced ShockBurst™ packet is described in this section. The Enhanced ShockBurst™ packet contains a preamble field, address field, packet control field, payload field and a CRC field. [Figure 7.](#) shows the packet format with MSB to the left.



Figure 7. An Enhanced ShockBurst™ packet with payload (0-32 bytes)

3.4.3.1 Preamble

The preamble is a bit sequence used to synchronize the receivers demodulator to the incoming bit stream. The preamble is one byte long and is either 01010101 or 10101010. If the first bit in the address is 1 the preamble is automatically set to 10101010 and if the first bit is 0 the preamble is automatically set to 01010101. This is done to ensure there are enough transitions in the preamble to stabilize the receiver.

3.4.3.2 Address

This is the address for the receiver. An address ensures that the correct packet is detected by the receiver. The address field can be configured to be 3, 4 or, 5 bytes long with the ΔW register.

Note: Addresses where the level shifts only one time (that is, 000FFFFFFF) can often be detected in noise and can give a false detection, which may give a raised Packet-Error-Rate. Addresses as a continuation of the preamble (hi-low toggling) raises the Packet-Error-Rate.

3.4.3.3 Packet Control Field

[Figure 8.](#) shows the format of the 9 bit packet control field, MSB to the left.



Figure 8. Packet control field

The packet control field contains a 6 bit payload length field, a 2 bit PID (Packet Identity) field and a 1 bit NO_ACK flag.

Payload length

This 6 bit field specifies the length of the payload in bytes. The length of the payload can be from 0 to 32 bytes.

Coding: 000000 = 0 byte (only used in empty ACK packets.) 100000 = 32 byte, 100001 = Don't care.

This field is only used if the Dynamic Payload Length function is enabled.

PID (Packet identification)

The 2 bit PID field is used to detect if the received packet is new or retransmitted. PID prevents the PRX operation from presenting the same payload more than once to the MCU. The PID field is incremented at the TX side for each new packet received through the SPI. The PID and CRC fields (see [section 3.4.3.5 on page 25](#)) are used by the PRX operation to determine if a packet is retransmitted or new. When several data packets are lost on the link, the PID fields may become equal to the last received PID. If a packet has the same PID as the previous packet, the RF transceiver compares the CRC sums from both packets. If the CRC sums are also equal, the last received packet is considered a copy of the previously received packet and discarded.

No Acknowledgment flag (NO_ACK)

The Selective Auto Acknowledgement feature controls the NO_ACK flag.

This flag is only used when the auto acknowledgement feature is used. Setting the flag high, tells the receiver that the packet is not to be auto acknowledged.

3.4.3.4 Payload

The payload is the user defined content of the packet. It can be 0 to 32 bytes wide and is transmitted on-air when it is uploaded (unmodified) to the device.

Enhanced ShockBurst™ provides two alternatives for handling payload lengths; static and dynamic.

The default is static payload length. With static payload length all packets between a transmitter and a receiver have the same length. Static payload length is set by the RX_PW_Px registers on the receiver side. The payload length on the transmitter side is set by the number of bytes clocked into the TX_FIFO and must equal the value in the RX_PW_Px register on the receiver side.

Dynamic Payload Length (DPL) is an alternative to static payload length. DPL enables the transmitter to send packets with variable payload length to the receiver. This means that for a system with different payload lengths it is not necessary to scale the packet length to the longest payload.

With the DPL feature the nRF24L01+ can decode the payload length of the received packet automatically instead of using the `RX_PW_Px` registers. The MCU can read the length of the received payload by using the `R_RX_PL_WID` command.

Note: Always check if the packet width reported is 32 bytes or shorter when using the `R_RX_PL_WID` command. If its width is longer than 32 bytes then the packet contains errors and must be discarded. Discard the packet by using the `Flush_RX` command.

In order to enable DPL the `EN_DPL` bit in the `FEATURE` register must be enabled. In RX mode the `DYNPD` register must be set. A PTX that transmits to a PRX with DPL enabled must have the `DPL_P0` bit in `DYNPD` set.

3.4.3.5 CRC (Cyclic Redundancy Check)

The CRC is the error detection mechanism in the packet. It may either be 1 or 2 bytes and is calculated over the address, Packet Control Field and Payload.

The polynomial for 1 byte CRC is $X^8 + X^2 + X + 1$. Initial value 0xFF.

The polynomial for 2 byte CRC is $X^{16} + X^{12} + X^5 + 1$. Initial value 0xFFFF.

No packet is accepted by Enhanced ShockBurst™ if the CRC fails.

3.4.4 Automatic packet assembly

The automatic packet assembly assembles the preamble, address, packet control field, payload and CRC to make a complete packet before it is transmitted.

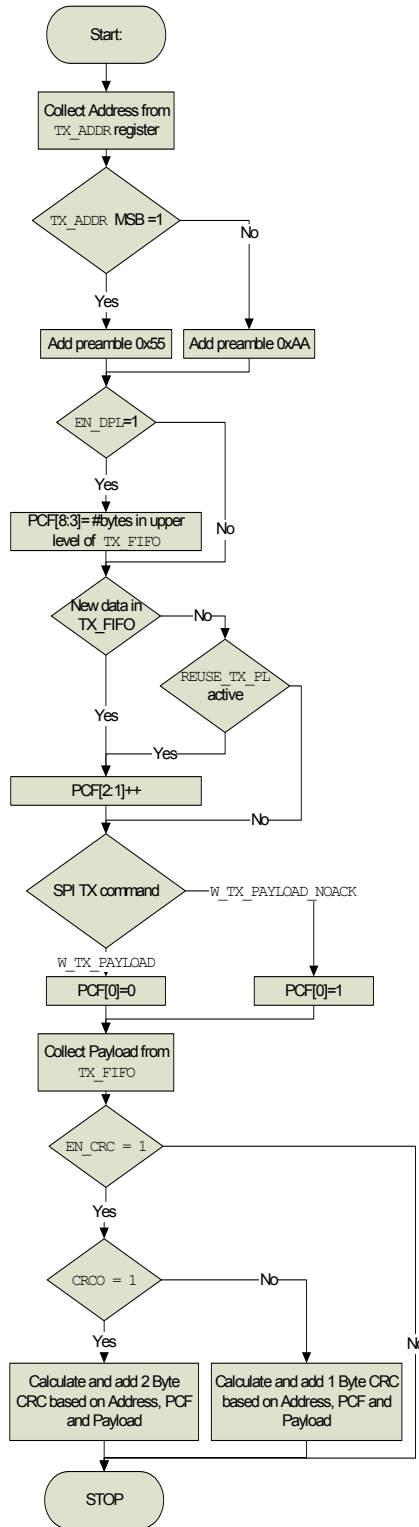

Figure 9. Automatic packet assembly

3.4.5 Automatic packet disassembly

After the packet is validated, Enhanced ShockBurst™ disassembles the packet and loads the payload into the RX FIFO, and asserts the `RX_DR` IRQ.

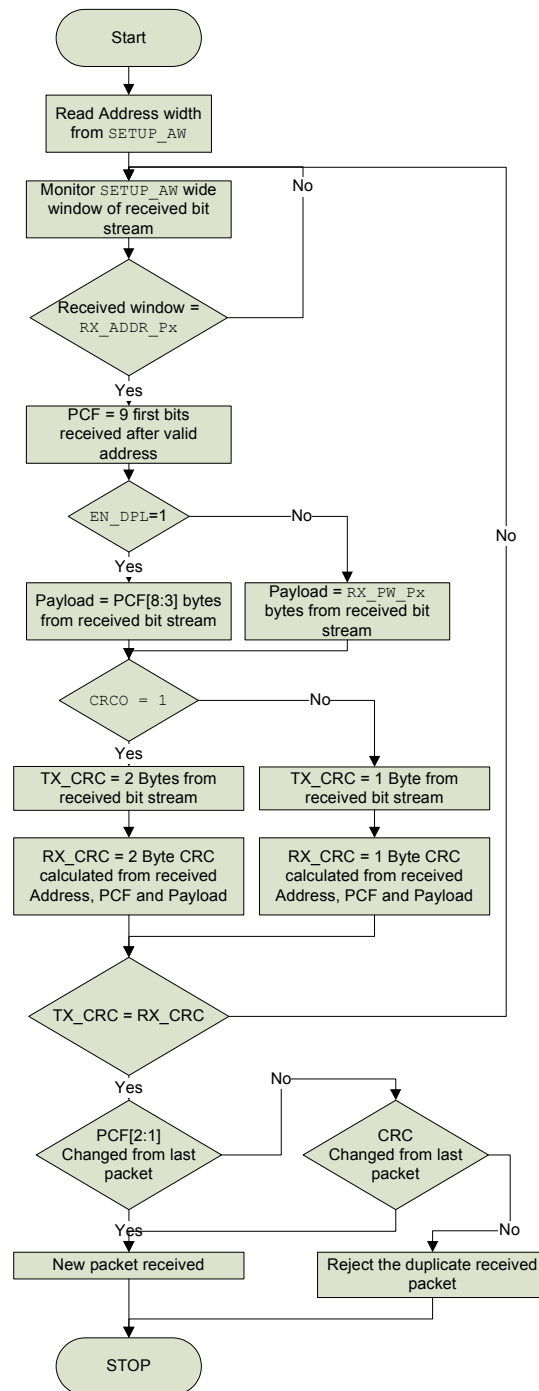

Figure 10. Automatic packet disassembly

3.4.6 Automatic packet transaction handling

Enhanced ShockBurst™ features two functions for automatic packet transaction handling; auto acknowledgement and auto re-transmit.

3.4.6.1 Auto Acknowledgement

Auto acknowledgement is a function that automatically transmits an ACK packet to the PTX after it has received and validated a packet. The auto acknowledgement function reduces the load of the system MCU and reduces average current consumption. The Auto Acknowledgement feature is enabled by setting the EN_AA register.

Note: If the received packet has the NO_ACK flag set, auto acknowledgement is not executed.

An ACK packet can contain an optional payload from PRX to PTX. In order to use this feature, the Dynamic Payload Length (DPL) feature must be enabled. The MCU on the PRX side has to upload the payload by clocking it into the TX FIFO by using the W_ACK_PAYLOAD command. The payload is pending in the TX FIFO (PRX) until a new packet is received from the PTX. The RF transceiver can have three ACK packet payloads pending in the TX FIFO (PRX) at the same time.

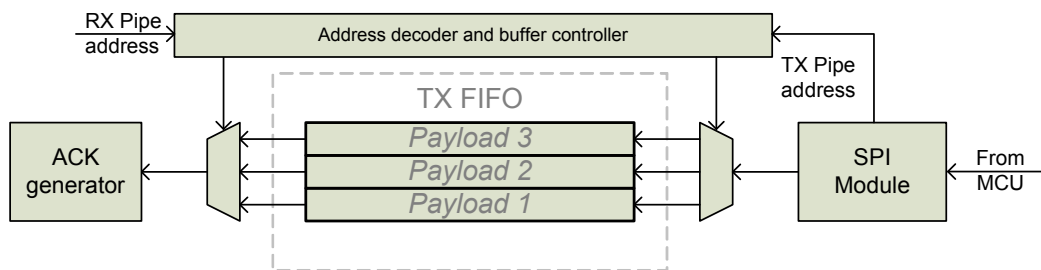

Figure 11. TX FIFO (PRX) with pending payloads

Figure 11 shows how the TX FIFO (PRX) is operated when handling pending ACK packet payloads. From the MCU the payload is clocked in with the W_ACK_PAYLOAD command. The address decoder and buffer controller ensure that the payload is stored in a vacant slot in the TX FIFO (PRX). When a packet is received, the address decoder and buffer controller are notified with the PTX address. This ensures that the right payload is presented to the ACK generator.

If the TX FIFO (PRX) contains more than one payload to a PTX, payloads are handled using the first in – first out principle. The TX FIFO (PRX) is blocked if all pending payloads are addressed to a PTX where the link is lost. In this case, the MCU can flush the TX FIFO (PRX) by using the FLUSH_TX command.

In order to enable Auto Acknowledgement with payload the EN_ACK_PAY bit in the FEATURE register must be set.

3.4.6.2 Auto Retransmission (ART)

The auto retransmission is a function that retransmits a packet if an ACK packet is not received. It is used in an auto acknowledgement system on the PTX. When a packet is not acknowledged, you can set the number of times it is allowed to retransmit by setting the ARC bits in the SETUP_RETR register. PTX enters RX mode and waits a time period for an ACK packet each time a packet is transmitted. The amount of time the PTX is in RX mode is based on the following conditions:

- Auto Retransmit Delay (ARD) elapsed.
- No address match within 250µs.
- After received packet (CRC correct or not) if address match within 250µs.

The RF transceiver asserts the TX_DS IRQ when the ACK packet is received.

The RF transceiver enters standby-I mode if there is no more untransmitted data in the TX FIFO and the rfcce bit in the RFCON register is low. If the ACK packet is not received, the RF transceiver goes back to TX mode after a delay defined by ARD and retransmits the data. This continues until acknowledgment is received, or the maximum number of retransmits is reached.

Two packet loss counters are incremented each time a packet is lost, ARC_CNT and PLOS_CNT in the OBSERVE_TX register. The ARC_CNT counts the number of retransmissions for the current transaction. You reset ARC_CNT by initiating a new transaction. The PLOS_CNT counts the total number of retransmissions since the last channel change. You reset PLOS_CNT by writing to the RF_CH register. It is possible to use the information in the OBSERVE_TX register to make an overall assessment of the channel quality.

The ARD defines the time from the end of a transmitted packet to when a retransmit starts on the PTX. ARD is set in SETUP_RETR register in steps of 250µs. A retransmit is made if no ACK packet is received by the PTX.

There is a restriction on the length of ARD when using ACK packets with payload. The ARD time must never be shorter than the sum of the startup time and the time on-air for the ACK packet.

- For 2Mbps data rate and 5-byte address; 15 byte is maximum ACK packet payload length for ARD=250µs (reset value).
- For 1Mbps data rate and 5-byte address; 5 byte is maximum ACK packet payload length for ARD=250µs (reset value).

ARD=500µs is long enough for any ACK payload length in 1 or 2Mbps mode.

- For 250kbps data rate and 5-byte address the following values apply:

ARD	ACK packet size (in bytes)
1500 µs	All ACK payload sizes
1250 µs	≤ 24
1000 µs	≤ 16
750 µs	≤ 8
500 µs	Empty ACK with no payload

Table 6. Maximum ACK payload length for different retransmit delays at 250 kbps

As an alternative to Auto Retransmit it is possible to manually set the RF transceiver to retransmit a packet a number of times. This is done by the REUSE_TX_PL command. The MCU must initiate each transmission of the packet with a pulse on the CE pin when this command is used.

3.4.7 Enhanced ShockBurst flowcharts

This section contains flowcharts outlining PTX and PRX operation in Enhanced ShockBurst™.

3.4.7.1 PTX operation

The flowchart in [Figure 12](#) outlines how a RF transceiver configured as a PTX behaves after entering standby-I mode.

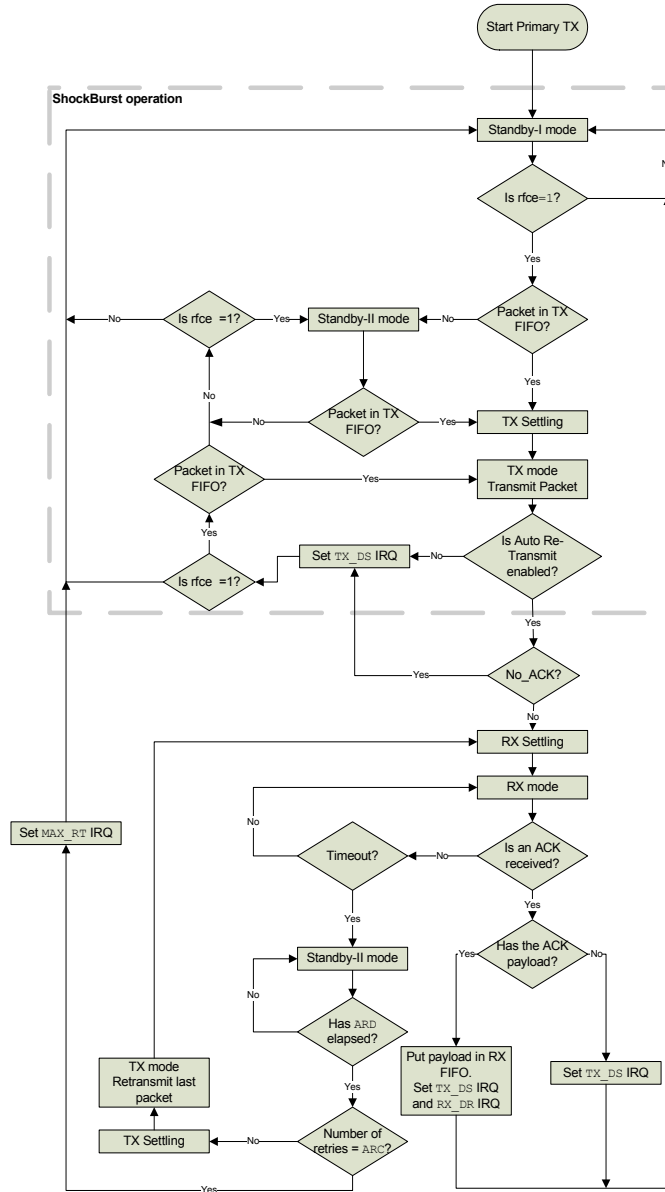

Note: ShockBurst™ operation is outlined with a dashed square.

Figure 12. PTX operations in Enhanced ShockBurst™

Activate PTX mode by setting the `rfce` bit in the `RFCON` register high. If there is a packet present in the TX FIFO the RF transceiver enters TX mode and transmits the packet. If Auto Retransmit is enabled, the state machine checks if the `NO_ACK` flag is set. If it is not set, the RF transceiver enters RX mode to receive an ACK packet. If the received ACK packet is empty, only the `TX_DS` IRQ is asserted. If the ACK packet contains a payload, both `TX_DS` IRQ and `RX_DR` IRQ are asserted simultaneously before the RF transceiver returns to standby-I mode.

If the ACK packet is not received before timeout occurs, the RF transceiver returns to standby-II mode. It stays in standby-II mode until the ARD has elapsed. If the number of retransmits has not reached the ARC, the RF transceiver enters TX mode and transmits the last packet once more.

While executing the Auto Retransmit feature, the number of retransmits can reach the maximum number defined in `ARC`. If this happens, the RF transceiver asserts the `MAX_RT` IRQ and returns to standby-I mode.

If the `rfce` bit in the `RFCON` register is high and the TX FIFO is empty, the RF transceiver enters Standby-II mode.

3.4.7.2 PRX operation

The flowchart in [Figure 13](#) outlines how a RF transceiver configured as a PRX behaves after entering standby-I mode.

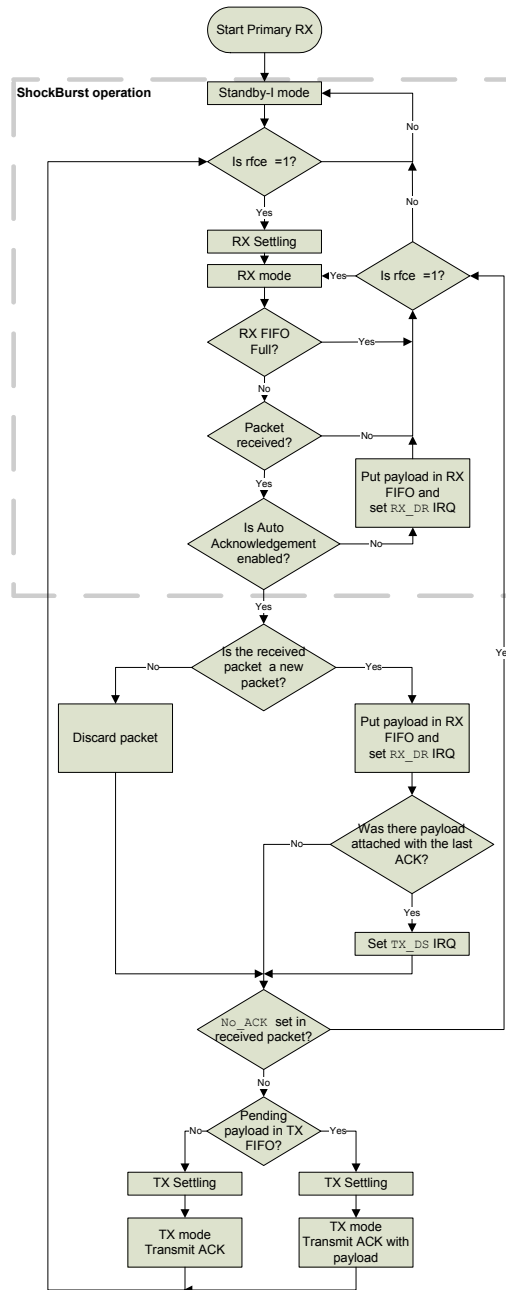

Note: ShockBurst™ operation is outlined with a dashed square.

Figure 13. PRX operations in Enhanced ShockBurst™

Activate PRX mode by setting the `rfce` bit in the `RFCON` register high. The RF transceiver enters RX mode and starts searching for packets. If a packet is received and Auto Acknowledgement is enabled, the RF transceiver decides if the packet is new or a copy of a previously received packet. If the packet is new the

payload is made available in the RX FIFO and the `RX_DR` IRQ is asserted. If the last received packet from the transmitter is acknowledged with an ACK packet with payload, the `TX_DS` IRQ indicates that the PTX received the ACK packet with payload. If the `NO_ACK` flag is not set in the received packet, the PRX enters TX mode. If there is a pending payload in the TX FIFO it is attached to the ACK packet. After the ACK packet is transmitted, the RF transceiver returns to RX mode.

A copy of a previously received packet might be received if the ACK packet is lost. In this case, the PRX discards the received packet and transmits an ACK packet before it returns to RX mode.

3.4.8 MultiCeiver™

MultiCeiver™ is a feature used in RX mode that contains a set of six parallel data pipes with unique addresses. A data pipe is a logical channel in the physical RF channel. Each data pipe has its own physical address (data pipe address) decoding in the RF transceiver.

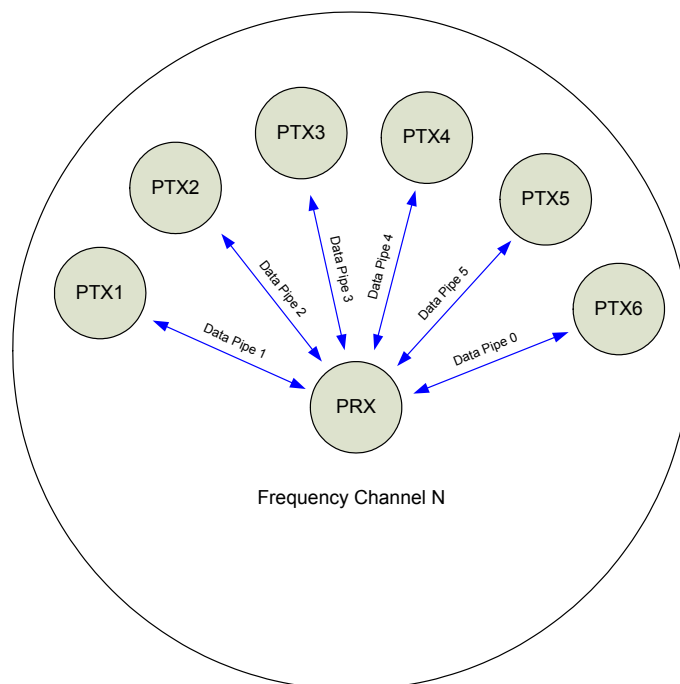

Figure 14. PRX using MultiCeiver™

The RF transceiver configured as PRX (primary receiver) can receive data addressed to six different data pipes in one frequency channel as shown in [Figure 14](#). Each data pipe has its own unique address and can be configured for individual behavior.

Up to six RF transceivers configured as PTX can communicate with one RF transceiver configured as PRX. All data pipe addresses are searched for simultaneously. Only one data pipe can receive a packet at a time. All data pipes can perform Enhanced ShockBurst™ functionality.

The following settings are common to all data pipes:

- CRC enabled/disabled (CRC always enabled when Enhanced ShockBurst™ is enabled)
- CRC encoding scheme
- RX address width
- Frequency channel

- Air data rate
- LNA gain

The data pipes are enabled with the bits in the EN_RXADDR register. By default only data pipe 0 and 1 are enabled. Each data pipe address is configured in the RX_ADDR_PX registers.

Note: Always ensure that none of the data pipes have the same address.

Each pipe can have up to a 5 byte configurable address. Data pipe 0 has a unique 5 byte address. Data pipes 1-5 share the four most significant address bytes. The LSByte must be unique for all six pipes. [Figure 15](#) is an example of how data pipes 0-5 are addressed.

	Byte 4	Byte 3	Byte 2	Byte 1	Byte 0
Data pipe 0 (RX_ADDR_P0)	0xE7	0xD3	0xF0	0x35	0x77
Data pipe 1 (RX_ADDR_P1)	0xC2	0xC2	0xC2	0xC2	0xC2
	↓	↓	↓	↓	
Data pipe 2 (RX_ADDR_P2)	0xC2	0xC2	0xC2	0xC2	0xC3
	↓	↓	↓	↓	
Data pipe 3 (RX_ADDR_P3)	0xC2	0xC2	0xC2	0xC2	0xC4
	↓	↓	↓	↓	
Data pipe 4 (RX_ADDR_P4)	0xC2	0xC2	0xC2	0xC2	0xC5
	↓	↓	↓	↓	
Data pipe 5 (RX_ADDR_P5)	0xC2	0xC2	0xC2	0xC2	0xC6

Figure 15. Addressing data pipes 0-5

The PRX, using MultiCeiver™ and Enhanced ShockBurst™, receives packets from more than one PTX. To ensure that the ACK packet from the PRX is transmitted to the correct PTX, the PRX takes the data pipe address where it received the packet and uses it as the TX address when transmitting the ACK packet. [Figure 16](#) is an example of an address configuration for the PRX and PTX. On the PRX the RX_ADDR_Pn, defined as the pipe address, must be unique. On the PTX the TX_ADDR must be the same as the RX_ADDR_P0 and as the pipe address for the designated pipe.

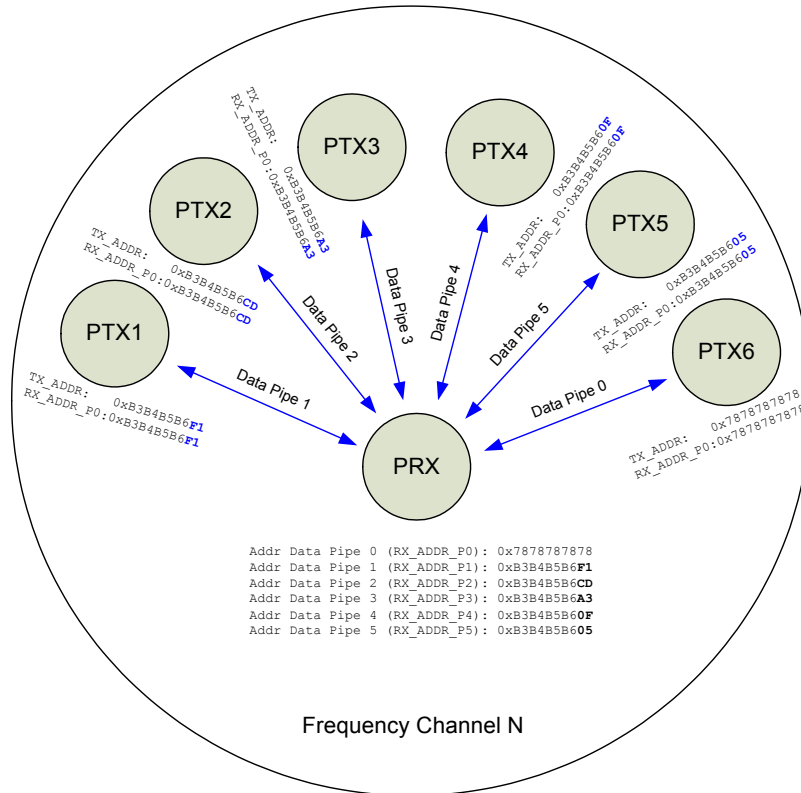

Figure 16. Example of data pipe addressing in MultiCeiver™

Only when a data pipe receives a complete packet can other data pipes begin to receive data. When multiple PTXs are transmitting to a PRX, the ARD can be used to skew the auto retransmission so that they only block each other once.

3.4.9 Enhanced ShockBurst™ timing

This section describes the timing sequence of Enhanced ShockBurst™ and how all modes are initiated and operated. The Enhanced ShockBurst™ timing is controlled through the Data and Control interface. The RF transceiver can be set to static modes or autonomous modes where the internal state machine

controls the events. Each autonomous mode/sequence ends with a `RFIRQ` interrupt. All the interrupts are indicated as IRQ events in the timing diagrams.

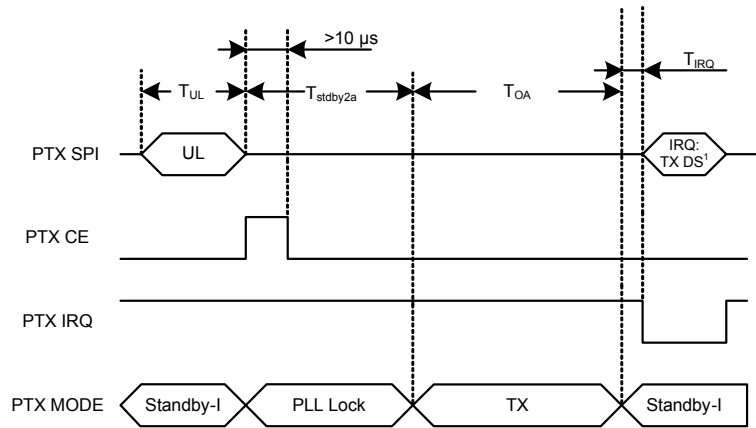

1 IRQ if No Ack is on.

$T_{IRQ} = 8.2 \mu s @ 1 \text{ Mbps}$, $T_{IRQ} = 6.0 \mu s @ 2 \text{ Mbps}$, $T_{stdby2a} = 130 \mu s$

Figure 17. Transmitting one packet with `NO_ACK` on

The following equations calculate various timing measurements:

Symbol	Description	Equation
T_{OA}	Time on-air	$T_{OA} = \frac{\text{packet length}}{\text{air data rate}} = \frac{8 \left[\frac{\text{bit}}{\text{byte}} \right] \cdot \left(1 \left[\text{byte} \right]_{\text{preamble}} + 3, 4 \text{ or } 5 \left[\text{bytes} \right]_{\text{address}} + N \left[\text{bytes} \right]_{\text{payload}} + 1 \text{ or } 2 \left[\text{bytes} \right]_{\text{CRC}} \right) + 9 \left[\text{bit} \right]_{\text{packet control field}}}{\text{air data rate} \left[\frac{\text{bit}}{\text{s}} \right]}$
T_{ACK}	Time on-air Ack	$T_{ACK} = \frac{\text{packet length}}{\text{air data rate}} = \frac{8 \left[\frac{\text{bit}}{\text{byte}} \right] \cdot \left(1 \left[\text{byte} \right]_{\text{preamble}} + 3, 4 \text{ or } 5 \left[\text{bytes} \right]_{\text{address}} + N \left[\text{bytes} \right]_{\text{payload}} + 1 \text{ or } 2 \left[\text{bytes} \right]_{\text{CRC}} \right) + 9 \left[\text{bit} \right]_{\text{packet control field}}}{\text{air data rate} \left[\frac{\text{bit}}{\text{s}} \right]}$
T_{UL}	Time Upload	$T_{UL} = \frac{\text{payload length}}{\text{SPI data rate}} = \frac{8 \left[\frac{\text{bit}}{\text{byte}} \right] \cdot N \left[\text{bytes} \right]_{\text{payload}}}{\text{SPI data rate} \left[\frac{\text{bit}}{\text{s}} \right]}$
T_{ESB}	Time Enhanced Shock-Burst™ cycle	$T_{ESB} = T_{UL} + 2 \cdot T_{stdby2a} + T_{OA} + T_{ACK} + T_{IRQ}$

Table 7. Timing equations

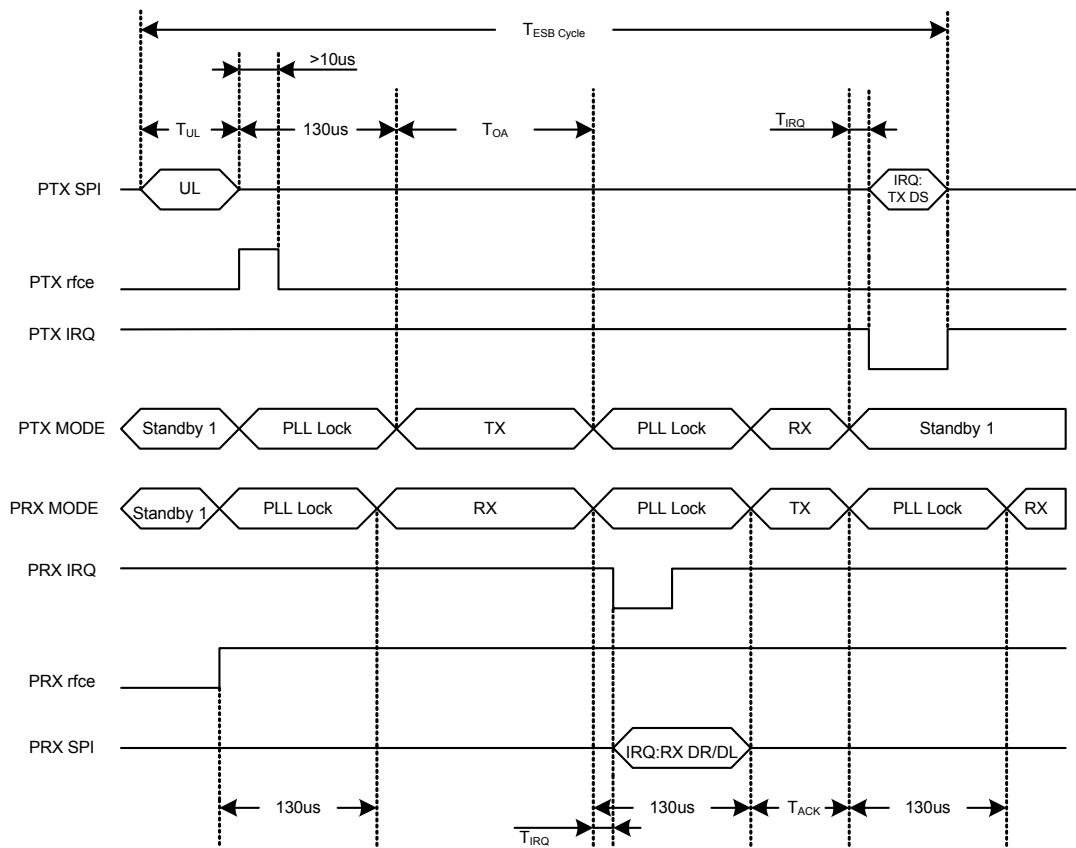

Figure 18. Timing of Enhanced ShockBurst™ for one packet upload (2 Mbps)

In [Figure 18](#), the transmission and acknowledgement of a packet is shown. The PRX operation activates RX mode ($rfce=1$), and the PTX operation is activated in TX mode ($rfce=1$ for minimum $10\mu s$). After $130\mu s$ the transmission starts and finishes after the elapse of T_{OA} .

When the transmission ends the PTX operation automatically switches to RX mode to wait for the ACK packet from the PRX operation. When the PRX operation receives the packet it sets the interrupt for the host MCU and switches to TX mode to send an ACK. After the PTX operation receives the ACK packet it sets the interrupt to the MCU and clears the packet from the TX FIFO.

In [Figure 19](#), the PTX timing of a packet transmission is shown when the first ACK packet is lost. To see the complete transmission when the ACK packet fails see [Figure 22. on page 40](#).

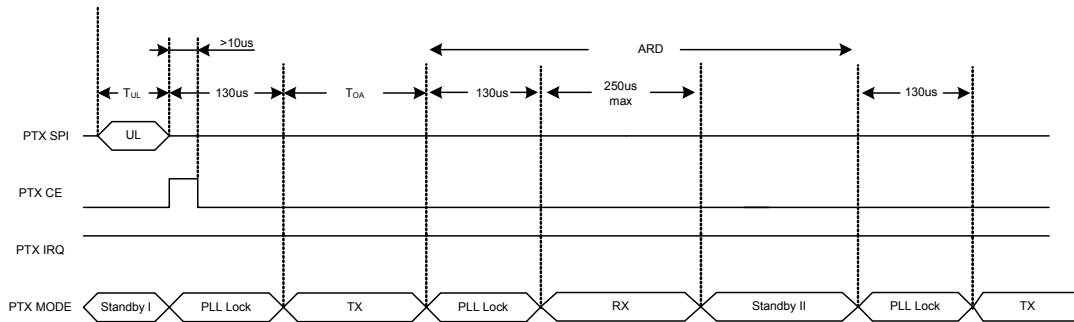

Figure 19. Timing of Enhanced ShockBurst™ when the first ACK packet is lost (2Mbps)

3.4.10 Enhanced ShockBurst™ transaction diagram

This section describes several scenarios for the Enhanced ShockBurst™ automatic transaction handling. The call outs in this section’s figures indicate the IRQs and other events. For MCU activity the event may be placed at a different timeframe.

Note: The figures in this section indicate the earliest possible download (DL) of the packet to the MCU and the latest possible upload (UL) of payload to the transmitter.

3.4.10.1 Single transaction with ACK packet and interrupts

In [Figure 20](#), the basic auto acknowledgement is shown. After the packet is transmitted by the PTX and received by the PRX the ACK packet is transmitted from the PRX to the PTX. The `RX_DR` IRQ is asserted after the packet is received by the PRX, whereas the `TX_DS` IRQ is asserted when the packet is acknowledged and the ACK packet is received by the PTX.

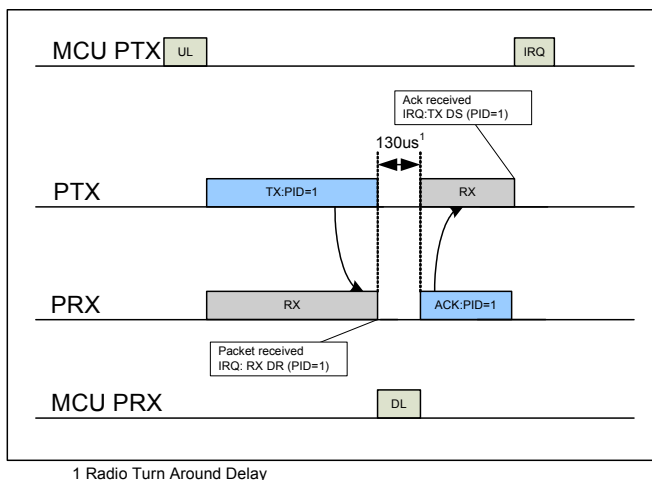

Figure 20. TX/RX cycles with ACK and the according interrupts

3.4.10.2 Single transaction with a lost packet

[Figure 21](#) is a scenario where a retransmission is needed due to loss of the first packet transmit. After the packet is transmitted, the PTX enters RX mode to receive the ACK packet. After the first transmission, the PTX waits a specified time for the ACK packet, if it is not in the specific time slot the PTX retransmits the packet as shown in [Figure 21](#).

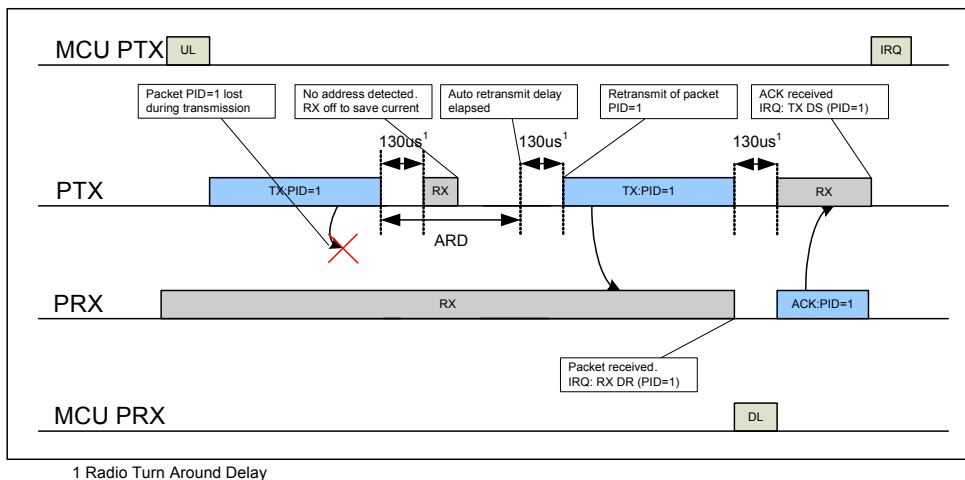

Figure 21. TX/RX cycles with ACK and the according interrupts when the first packet transmit fails

When an address is detected the PTX stays in RX mode until the packet is received. When the retransmitted packet is received by the PRX (see [Figure 21. on page 39](#)), the `RX_DR` IRQ is asserted and an ACK is transmitted back to the PTX. When the ACK is received by the PTX, the `TX_DS` IRQ is asserted.

3.4.10.3 Single transaction with a lost ACK packet

[Figure 22.](#) is a scenario where a retransmission is needed after a loss of the ACK packet. The corresponding interrupts are also indicated.

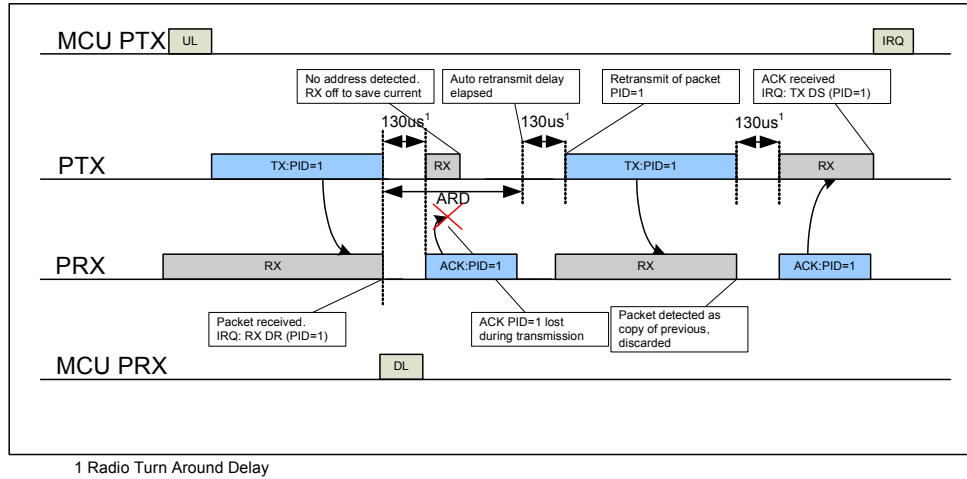

Figure 22. TX/RX cycles with ACK and the according interrupts when the ACK packet fails

3.4.10.4 Single transaction with ACK payload packet

[Figure 23.](#) is a scenario of the basic auto acknowledgement with payload. After the packet is transmitted by the PTX and received by the PRX the ACK packet with payload is transmitted from the PRX to the PTX. The `RX_DR` IRQ is asserted after the packet is received by the PRX, whereas on the PTX side the `TX_DS` IRQ is asserted when the ACK packet is received by the PTX. On the PRX side, the `TX_DS` IRQ for the ACK packet payload is asserted after a new packet from PTX is received. The position of the IRQ in [Figure 23.](#) shows where the MCU can respond to the interrupt.

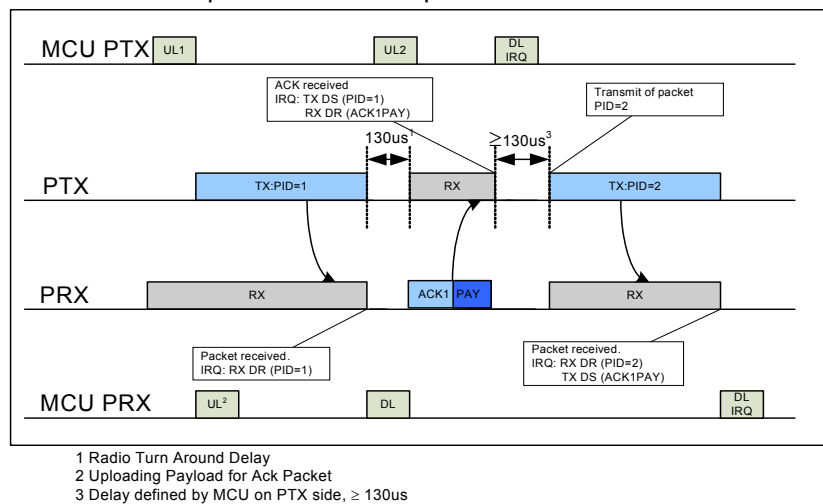

Figure 23. TX/RX cycles with ACK Payload and the according interrupts

3.4.10.5 Single transaction with ACK payload packet and lost packet

Figure 24 is a scenario where the first packet is lost and a retransmission is needed before the RX_DR IRQ on the PRX side is asserted. For the PTX both the TX_DS and RX_DR IRQ are asserted after the ACK packet is received. After the second packet (PID=2) is received on the PRX side both the RX_DR (PID=2) and TX_DS (ACK packet payload) IRQ are asserted.

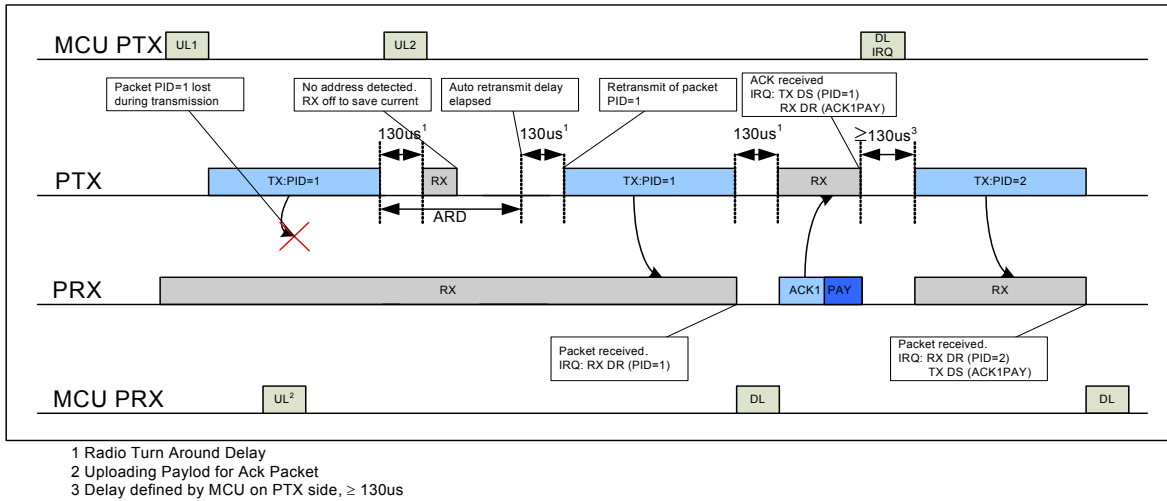

Figure 24. TX/RX cycles and the according interrupts when the packet transmission fails

3.4.10.6 Two transactions with ACK payload packet and the first ACK packet lost

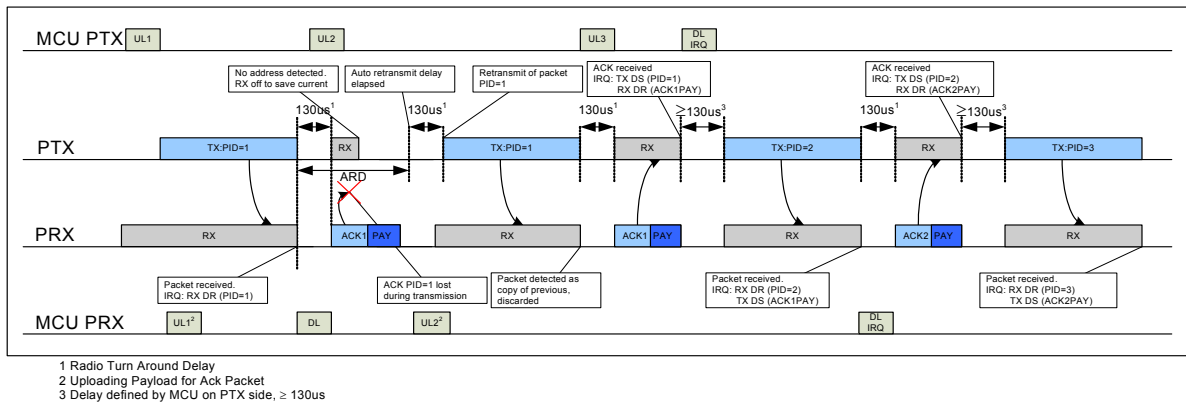

Figure 25. TX/RX cycles with ACK Payload and the according interrupts when the ACK packet fails

In Figure 25, the ACK packet is lost and a retransmission is needed before the TX_DS IRQ is asserted, but the RX_DR IRQ is asserted immediately. The retransmission of the packet (PID=1) results in a discarded packet. For the PTX both the TX_DS and RX_DR IRQ are asserted after the second transmission of ACK, which is received. After the second packet (PID=2) is received on the PRX both the RX_DR (PID=2) and TX_DS (ACK1PAY) IRQ is asserted. The callouts explain the different events and interrupts.

3.4.10.7 Two transactions where max retransmissions is reached

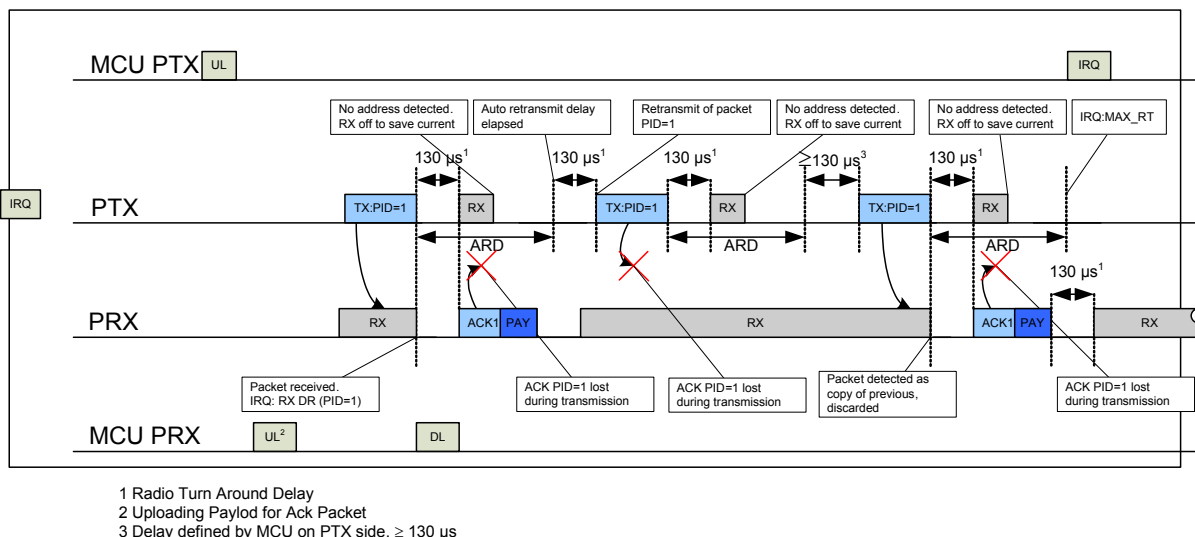

Figure 26. TX/RX cycles with ACK Payload and the according interrupts when the transmission fails. ARC is set to 2.

MAX_RT IRQ is asserted if the auto retransmit counter (ARC_CNT) exceeds the programmed maximum limit (ARC). In Figure 26, the packet transmission ends with a MAX_RT IRQ. The payload in TX FIFO is NOT removed and the MCU decides the next step in the protocol. A toggle of the rfce bit in the RCON register starts a new transmitting sequence of the same packet. The payload can be removed from the TX FIFO using the FLUSH_TX command.

3.4.11 Compatibility with ShockBurst™

You must disable Enhanced ShockBurst™ for backward compatibility with the nRF2401A, nRF2402, nRF24E1 and, nRF24E2. Set the register EN_AA = 0x00 and ARC = 0 to disable Enhanced ShockBurst™. In addition, the RF transceiver air data rate must be set to 1Mbps or 250kbps.

3.4.11.1 ShockBurst™ packet format

The ShockBurst™ packet format is described in this chapter. Figure 27. shows the packet format with MSB to the left.

Preamble 1 byte	Address 3-5 byte	Payload 1 - 32 byte	CRC 1-2 byte
-----------------	------------------	---------------------	--------------

Figure 27. A ShockBurst™ packet compatible with nRF2401/nRF2402/nRF24E1/nRF24E2 devices.

The ShockBurst™ packet format has a preamble, address, payload and CRC field that are the same as the Enhanced ShockBurst™ packet format described in [section 3.4.3 on page 23](#).

The differences between the ShockBurst™ packet and the Enhanced ShockBurst™ packet are:

- The 9 bit Packet Control Field is not present in the ShockBurst™ packet format.

- The CRC is optional in the ShockBurst™ packet format and is controlled by the EN_CRC bit in the CONFIG register.

3.5 Data and control interface

The data and control interface gives you access to all the features in the RF transceiver. Compared to the standalone component SFR registers are used instead of port pins. Otherwise the interface is identical to the standalone nRF24L01+ chip.

3.5.1 SFR registers

Address (Hex)	Name/Mnemonic	Bit	Reset value	Type	Description
0xE4	SPIRCON0	6:0	0x01	R/W	SPI Master configuration register 0. Reserved. Do not alter.
0xE5	SPIRCON1	3:0	0x0F	R/W	SPI Master configuration register 1.
	<i>maskIrqRxFifoFull</i>	3	1	R/W	1: Disable interrupt when RX FIFO is full. 0: Enable interrupt when RX FIFO is full.
	<i>maskIrqRxDataReady</i>	2	1	R/W	1: Disable interrupt when data is available in RX FIFO. 0: Enable interrupt when data is available in RX FIFO.
	<i>maskIrqTxFifoEmpty</i>	1	1	R/W	1: Disable interrupt when TX FIFO is empty. 0: Enable interrupt when TX FIFO is empty.
	<i>maskIrqTxFifoReady</i>	0	1	R/W	1: Disable interrupt when a location is available in TX FIFO. 0: Enable interrupt when a location is available in TX FIFO.
0xE6	spiMasterStatus SPIRSTAT	3:0	0x03	R	SPI Master status register.
	<i>rxFifoFull</i>	3	0	R	Interrupt source. 1: RX FIFO full. 0: RX FIFO can accept more data from SPI. Cleared when the cause is removed.
	<i>rxDataReady</i>	2	0	R	Interrupt source. 1: Data available in RX FIFO. 0: No data in RX FIFO. Cleared when the cause is removed.
	<i>txFifoEmpty</i>	1	1	R	Interrupt source. 1: TX FIFO empty. 0: Data in TX FIFO. Cleared when the cause is removed.
	<i>txFifoReady</i>	0	1	R	Interrupt source. 1: Location available in TX FIFO. 0: TX FIFO full. Cleared when the cause is removed.
0xE7	SPIRDAT	7:0	0x00	R/W	SPI Master data register. Accesses TX (write) and RX (read) FIFO buffers, both two bytes deep.

Table 8. RF transceiver SPI master registers

The RF transceiver SPI Master is configured through `SPIRCON1`. Four different sources can generate interrupt, unless they are masked by their respective bits in `SPIRCON1`. `SPIRSTAT` reveals which sources that are active.

`SPIRDAT` accesses both the TX (write) and the RX (read) FIFOs, which are two bytes deep. The FIFOs are dynamic and can be refilled according to the state of the status flags: "FIFO ready" means that the FIFO can accept data. "Data ready" means that the FIFO can provide data, minimum one byte.

Addr	Bit	Name	R/W	Function
0xE8	7:3	-		Reserved
	2	rfcken	RW	RF Clock Enable (16 MHz)
	1	rfcsn	RW	Enable RF command. 0: enabled
	0	rfce	RW	Enable RF Transceiver. 1: enabled

Table 9. RFCON register

RFCON controls the RF transceiver SPI Slave chip select signal (CSN), the RF transceiver chip enable signal (CE) and the RF transceiver clock enable signal (CKEN).

3.5.2 SPI operation

This section describes the SPI commands and timing.

3.5.2.1 SPI commands

The SPI commands are shown in [Table 10. on page 45](#) Every new command must be started by writing 0 to `rfcsn` in the `RFCON` register.

The SPI command is transferred to RF transceiver by writing the command to the `SPIRDAT` register. After the first transfer the RF transceiver's `STATUS` register can be read from `SPIRDAT` when the transfer is completed.

The serial shifting SPI commands is in the following format:

<Command word: MSBit to LSBit (one byte)>

<Data bytes: LSByte to MSByte, MSBit in each byte first>

Command name	Command word (binary)	# Data bytes	Operation
R_REGISTER	000A AAAA	1 to 5 LSByte first	Read command and <i>status</i> registers. AAAAA = 5 bit Register Map Address
W_REGISTER	001A AAAA	1 to 5 LSByte first	Write command and <i>status</i> registers. AAAAA = 5 bit Register Map Address Executable in power down or standby modes only.
R_RX_PAYLOAD	0110 0001	1 to 32 LSByte first	Read RX-payload: 1 – 32 bytes. A read operation always starts at byte 0. Payload is deleted from FIFO after it is read. Used in RX mode.
W_TX_PAYLOAD	1010 0000	1 to 32 LSByte first	Write TX-payload: 1 – 32 bytes. A write operation always starts at byte 0 used in TX payload.
FLUSH_TX	1110 0001	0	Flush TX FIFO, used in TX mode
FLUSH_RX	1110 0010	0	Flush RX FIFO, used in RX mode Should not be executed during transmission of acknowledge, that is, acknowledge package will not be completed.
REUSE_TX_PL	1110 0011	0	Used for a PTX operation Reuse last transmitted payload. TX payload reuse is active until W_TX_PAYLOAD or FLUSH TX is executed. TX payload reuse must not be activated or deactivated during package transmission.
R_RX_PL_WID ^a	0110 0000	1	Read RX payload width for the top R_RX_PAYLOAD in the RX FIFO. Note: Flush RX FIFO if the read value is larger than 32 bytes.
W_ACK_PAYLOAD ^a	1010 1PPP	1 to 32 LSByte first	Used in RX mode. Write Payload to be transmitted together with ACK packet on PIPE PPP. (PPP valid in the range from 000 to 101). Maximum three ACK packet payloads can be pending. Payloads with same PPP are handled using first in - first out principle. Write payload: 1– 32 bytes. A write operation always starts at byte 0.
W_TX_PAYLOAD_NOACK ^a	1011 0000	1 to 32 LSByte first	Used in TX mode. Disables AUTOACK on this specific packet.
NOP	1111 1111	0	No Operation. Might be used to read the STATUS register

a. The bits in the FEATURE register shown in [Table 11. on page 53](#) have to be set.

Table 10. Command set for the RF transceiver SPI

The W_REGISTER and R_REGISTER commands operate on single or multi-byte registers. When accessing multi-byte registers read or write to the MSBit of LSByte first. You can terminate the writing before all bytes in a multi-byte register are written, leaving the unwritten MSByte(s) unchanged. For example, the LSByte of RX_ADDR_P0 can be modified by writing only one byte to the RX_ADDR_P0 register. The content of the *status* register is always read to MISO after a high to low transition on CSN.

Note: The 3 bit pipe information in the `STATUS` register is updated during the `RFIRQ` high to low transition. The pipe information is unreliable if the `STATUS` register is read during an `RFIRQ` high to low transition.

3.5.3 Data FIFO

The data FIFOs store transmitted payloads (TX FIFO) or received payloads that are ready to be clocked out (RX FIFO). The FIFOs are accessible in both PTX mode and PRX mode.

The following FIFOs are present in the RF transceiver:

- TX three level, 32 byte FIFO
- RX three level, 32 byte FIFO

Both FIFOs have a controller and are accessible through the SPI by using dedicated SPI commands. A TX FIFO in PRX can store payloads for ACK packets to three different PTX operations. If the TX FIFO contains more than one payload to a pipe, payloads are handled using the first in - first out principle. The TX FIFO in a PRX is blocked if all pending payloads are addressed to pipes where the link to the PTX is lost. In this case, the MCU can flush the TX FIFO using the `FLUSH_TX` command.

The RX FIFO in PRX can contain payloads from up to three different PTX operations and a TX FIFO in PTX can have up to three payloads stored.

You can write to the TX FIFO using these three commands; `W_TX_PAYLOAD` and `W_TX_PAYLOAD_NO_ACK` in PTX mode and `W_ACK_PAYLOAD` in PRX mode. All three commands provide access to the `TX_PLD` register.

The RX FIFO can be read by the command `R_RX_PAYLOAD` in PTX and PRX mode. This command provides access to the `RX_PLD` register.

The payload in TX FIFO in a PTX is not removed if the `MAX_RT` IRQ is asserted.

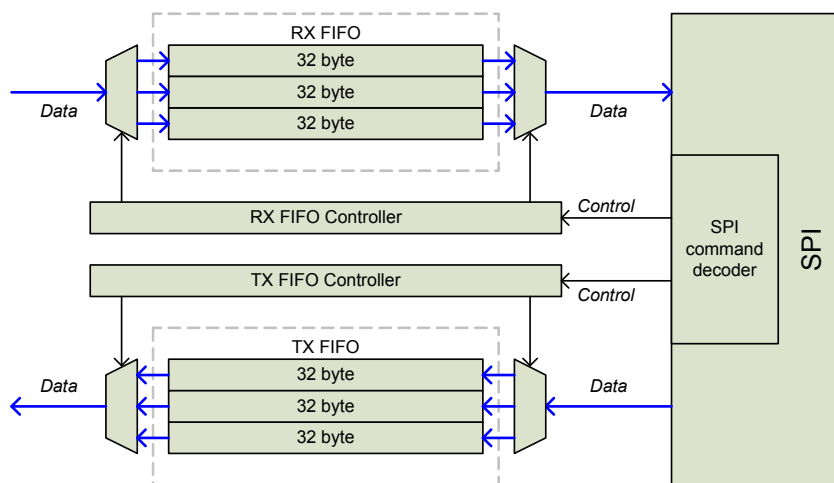

Figure 28. FIFO (RX and TX) block diagram

You can read if the TX and RX FIFO are full or empty in the `FIFO_STATUS` register. `TX_REUSE` (also available in the `FIFO_STATUS` register) is set by the SPI command `REUSE_TX_PL`, and is reset by the SPI commands `W_TX_PAYLOAD` or `FLUSH_TX`.

3.5.4 Interrupt

The RF transceiver can send interrupts to the MCU. The interrupt (RFIRQ) is activated when TX_DS, RX_DR or MAX_RT are set high by the state machine in the STATUS register. RFIRQ is deactivated when the MCU writes '1' to the interrupt source bit in the STATUS register. The interrupt mask in the CONFIG register is used to select the IRQ sources that are allowed to activate RFIRQ. By setting one of the mask bits high, the corresponding interrupt source is disabled. By default all interrupt sources are enabled.

Note: The 3 bit pipe information in the STATUS register is updated during the RFIRQ high to low transition. The pipe information is unreliable if the STATUS register is read during a RFIRQ high to low transition.

3.6 Register map

You can configure and control the radio (using read and write commands) by accessing the register map through the SPI.

3.6.1 Register map table

All undefined bits in the table below are redundant. They are read out as '0'.

Note: Addresses 18 to 1B are reserved for test purposes, altering them makes the chip malfunction.

Address (Hex)	Mnemonic	Bit	Reset Value	Type	Description
00	CONFIG				Configuration Register
	Reserved	7	0	R/W	Only '0' allowed
	MASK_RX_DR	6	0	R/W	Mask interrupt caused by RX_DR 1: Interrupt not reflected on the RFIRQ 0: Reflect RX_DR as active low on RFIRQ
	MASK_TX_DS	5	0	R/W	Mask interrupt caused by TX_DS 1: Interrupt not reflected on the RFIRQ 0: Reflect TX_DS as active low interrupt on RFIRQ
	MASK_MAX_RT	4	0	R/W	Mask interrupt caused by MAX_RT 1: Interrupt not reflected on RFIRQ 0: Reflect MAX_RT as active low on RFIRQ
	EN_CRC	3	1	R/W	Enable CRC. Forced high if one of the bits in the EN_AA is high
	CRCO	2	0	R/W	CRC encoding scheme '0' - 1 byte '1' - 2 bytes
	PWR_UP	1	0	R/W	1: POWER UP, 0: POWER DOWN
	PRIM_RX	0	0	R/W	RX/TX control 1: PRX, 0: PTX
01	EN_AA Enhanced ShockBurst™				Enable 'Auto Acknowledgment' Function Disable this functionality to be compatible with nRF2401.
	Reserved	7:6	00	R/W	Only '00' allowed
	ENAA_P5	5	1	R/W	Enable auto acknowledgement data pipe 5
	ENAA_P4	4	1	R/W	Enable auto acknowledgement data pipe 4
	ENAA_P3	3	1	R/W	Enable auto acknowledgement data pipe 3
	ENAA_P2	2	1	R/W	Enable auto acknowledgement data pipe 2
	ENAA_P1	1	1	R/W	Enable auto acknowledgement data pipe 1
	ENAA_P0	0	1	R/W	Enable auto acknowledgement data pipe 0
02	EN_RXADDR				Enabled RX Addresses
	Reserved	7:6	00	R/W	Only '00' allowed
	ERX_P5	5	0	R/W	Enable data pipe 5.
	ERX_P4	4	0	R/W	Enable data pipe 4.
	ERX_P3	3	0	R/W	Enable data pipe 3.
	ERX_P2	2	0	R/W	Enable data pipe 2.
	ERX_P1	1	1	R/W	Enable data pipe 1.
	ERX_P0	0	1	R/W	Enable data pipe 0.

Address (Hex)	Mnemonic	Bit	Reset Value	Type	Description
03	SETUP_AW				Setup of Address Widths (common for all data pipes)
	Reserved	7:2	000000	R/W	Only '000000' allowed
	AW	1:0	11	R/W	RX/TX Address field width '00' - Illegal '01' - 3 bytes '10' - 4 bytes '11' - 5 bytes LSByte is used if address width is below 5 bytes
04	SETUP_RETR				Setup of Automatic Retransmission
	ARD ^a	7:4	0000	R/W	Auto Retransmit Delay '0000' - Wait 250µs '0001' - Wait 500µs '0010' - Wait 750µs '1111' - Wait 4000µs (Delay defined from end of transmission to start of next transmission) ^b
	ARC	3:0	0011	R/W	Auto Retransmit Count '0000' - Re-Transmit disabled '0001' - Up to 1 Re-Transmit on fail of AA '1111' - Up to 15 Re-Transmit on fail of AA
05	RF_CH				RF Channel
	Reserved	7	0	R/W	Only '0' allowed
	RF_CH	6:0	0000010	R/W	Sets the frequency channel the RF Transceiver operates on
06	RF_SETUP				RF Setup Register
	CONT_WAVE	7	0	R/W	Enables continuous carrier transmit when high.
	Reserved	6	0	R/W	Only '0' allowed
	RF_DR_LOW	5	0	R/W	Set RF Data Rate to 250kbps. See RF_DR_HIGH for encoding.
	PLL_LOCK	4	0	R/W	Force PLL lock signal. Only used in test
	RF_DR_HIGH	3	1	R/W	Select between the high speed data rates. This bit is don't care if RF_DR_LOW is set. Encoding: RF_DR_LOW, RF_DR_HIGH: '00' - 1Mbps '01' - 2Mbps '10' - 250kbps '11' - Reserved
	RF_PWR	2:1	11	R/W	Set RF output power in TX mode '00' - -18dBm '01' - -12dBm '10' - -6dBm '11' - 0dBm

Address (Hex)	Mnemonic	Bit	Reset Value	Type	Description
	Obsolete	0			Don't care
07	STATUS				Status Register (In parallel to the SPI command word applied on the MOSI pin, the STATUS register is shifted serially out on the MISO pin)
	Reserved	7	0	R/W	Only '0' allowed
	RX_DR	6	0	R/W	Data Ready RX FIFO interrupt. Asserted when new data arrives RX FIFO ^c . Write 1 to clear bit.
	TX_DS	5	0	R/W	Data Sent TX FIFO interrupt. Asserted when packet transmitted on TX. If AUTO_ACK is activated, this bit is set high only when ACK is received. Write 1 to clear bit.
	MAX_RT	4	0	R/W	Maximum number of TX retransmits interrupt Write 1 to clear bit. If MAX_RT is asserted it must be cleared to enable further communication.
	RX_P_NO	3:1	111	R	Data pipe number for the payload available for reading from RX_FIFO 000-101: Data Pipe Number 110: Not Used 111: RX FIFO Empty
	TX_FULL	0	0	R	TX FIFO full flag. 1: TX FIFO full. 0: Available locations in TX FIFO.
08	OBSERVE_TX				Transmit observe register
	PLOS_CNT	7:4	0	R	Count lost packets. The counter is overflow protected to 15, and discontinues at max until reset. The counter is reset by writing to RF_CH .
	ARC_CNT	3:0	0	R	Count retransmitted packets. The counter is reset when transmission of a new packet starts.
09	RPD				
	Reserved	7:1	000000	R	
	RPD	0	0	R	Received Power Detector. This register is called CD (Carrier Detect) in the nRF24L01. The name is different in the RF transceiver due to the different input power level threshold for this bit. See section 3.3.4 on page 21 .
0A	RX_ADDR_P0	39:0	0xE7E7E7E7E7	R/W	Receive address data pipe 0. 5 Bytes maximum length. (LSByte is written first. Write the number of bytes defined by SETUP_AW)
0B	RX_ADDR_P1	39:0	0xC2C2C2C2C2	R/W	Receive address data pipe 1. 5 Bytes maximum length. (LSByte is written first. Write the number of bytes defined by SETUP_AW)
0C	RX_ADDR_P2	7:0	0xC3	R/W	Receive address data pipe 2. Only LSB. MSBytes are equal to RX_ADDR_P1 39:8
0D	RX_ADDR_P3	7:0	0xC4	R/W	Receive address data pipe 3. Only LSB. MSBytes are equal to RX_ADDR_P1 39:8

Address (Hex)	Mnemonic	Bit	Reset Value	Type	Description
0E	RX_ADDR_P4	7:0	0xC5	R/W	Receive address data pipe 4. Only LSB. MSBytes are equal to RX_ADDR_P[139:8]
0F	RX_ADDR_P5	7:0	0xC6	R/W	Receive address data pipe 5. Only LSB. MSBytes are equal to RX_ADDR_P[139:8]
10	TX_ADDR	39:0	0xE7E7E7E7	R/W	Transmit address. Used for a PTX operation only. (LSByte is written first) Set RX_ADDR_P0 equal to this address to handle automatic acknowledge if this is a PTX operation with Enhanced ShockBurst™ enabled.
11	RX_PW_P0				
	Reserved	7:6	00	R/W	Only '00' allowed
	RX_PW_P0	5:0	0	R/W	Number of bytes in RX payload in data pipe 0 (1 to 32 bytes). 0 Pipe not used 1 = 1 byte ... 32 = 32 bytes
12	RX_PW_P1				
	Reserved	7:6	00	R/W	Only '00' allowed
	RX_PW_P1	5:0	0	R/W	Number of bytes in RX payload in data pipe 1 (1 to 32 bytes). 0 Pipe not used 1 = 1 byte ... 32 = 32 bytes
13	RX_PW_P2				
	Reserved	7:6	00	R/W	Only '00' allowed
	RX_PW_P2	5:0	0	R/W	Number of bytes in RX payload in data pipe 2 (1 to 32 bytes). 0 Pipe not used 1 = 1 byte ... 32 = 32 bytes
14	RX_PW_P3				
	Reserved	7:6	00	R/W	Only '00' allowed
	RX_PW_P3	5:0	0	R/W	Number of bytes in RX payload in data pipe 3 (1 to 32 bytes). 0 Pipe not used 1 = 1 byte ... 32 = 32 bytes
15	RX_PW_P4				
	Reserved	7:6	00	R/W	Only '00' allowed

Address (Hex)	Mnemonic	Bit	Reset Value	Type	Description
	RX_PW_P4	5:0	0	R/W	Number of bytes in RX payload in data pipe 4 (1 to 32 bytes). 0 Pipe not used 1 = 1 byte ... 32 = 32 bytes
16	RX_PW_P5				
	Reserved	7:6	00	R/W	Only '00' allowed
	RX_PW_P5	5:0	0	R/W	Number of bytes in RX payload in data pipe 5 (1 to 32 bytes). 0 Pipe not used 1 = 1 byte ... 32 = 32 bytes
17	FIFO_STATUS				FIFO Status Register
	Reserved	7	0	R/W	Only '0' allowed
	TX_REUSE	6	0	R	Used for a PTX operation Pulse the <i>rfce</i> high for at least 10µs to Reuse last transmitted payload. TX payload reuse is active until <i>W_TX_PAYLOAD</i> or <i>FLUSH_TX</i> is executed. <i>TX_REUSE</i> is set by the SPI command <i>REUSE_TX_PL</i> , and is reset by the SPI commands <i>W_TX_PAYLOAD</i> or <i>FLUSH_TX</i>
	TX_FULL	5	0	R	TX FIFO full flag. 1: TX FIFO full. 0: Available locations in TX FIFO.
	TX_EMPTY	4	1	R	TX FIFO empty flag. 1: TX FIFO empty. 0: Data in TX FIFO.
	Reserved	3:2	00	R/W	Only '00' allowed
	RX_FULL	1	0	R	RX FIFO full flag. 1: RX FIFO full. 0: Available locations in RX FIFO.
	RX_EMPTY	0	1	R	RX FIFO empty flag. 1: RX FIFO empty. 0: Data in RX FIFO.
N/A	ACK_PLD	255:0	X	W	Written by separate SPI command ACK packet payload to data pipe number PPP given in SPI command. Used in RX mode only. Maximum three ACK packet payloads can be pending. Payloads with same PPP are handled first in first out.
N/A	TX_PLD	255:0	X	W	Written by separate SPI command TX data payload register 1 - 32 bytes. This register is implemented as a FIFO with three levels. Used in TX mode only.

Address (Hex)	Mnemonic	Bit	Reset Value	Type	Description
N/A	RX_PLD	255:0	X	R	Read by separate SPI command. RX data payload register. 1 - 32 bytes. This register is implemented as a FIFO with three levels. All RX channels share the same FIFO.
1C	DYNPD				Enable dynamic payload length
	Reserved	7:6	0	R/W	Only '00' allowed
	DPL_P5	5	0	R/W	Enable dynamic payload length data pipe 5. (Requires EN_DPL and ENAA_P5)
	DPL_P4	4	0	R/W	Enable dynamic payload length data pipe 4. (Requires EN_DPL and ENAA_P4)
	DPL_P3	3	0	R/W	Enable dynamic payload length data pipe 3. (Requires EN_DPL and ENAA_P3)
	DPL_P2	2	0	R/W	Enable dynamic payload length data pipe 2. (Requires EN_DPL and ENAA_P2)
	DPL_P1	1	0	R/W	Enable dynamic payload length data pipe 1. (Requires EN_DPL and ENAA_P1)
	DPL_P0	0	0	R/W	Enable dynamic payload length data pipe 0. (Requires EN_DPL and ENAA_P0)
1D	FEATURE			R/W	Feature Register
	Reserved	7:3	0	R/W	Only '00000' allowed
	EN_DPL	2	0	R/W	Enables Dynamic Payload Length
	EN_ACK_PAY ^d	1	0	R/W	Enables Payload with ACK
	EN_DYN_ACK	0	0	R/W	Enables the W_TX_PAYLOAD_NOACK command

- Please take care when setting this parameter. If the ACK payload is more than 15 byte in 2 Mbps mode the ARD must be 500 μ s or more, if the ACK payload is more than 5 byte in 1Mbps mode the ARD must be 500 μ s or more. In 250 kbps mode (even when the payload is not in ACK) the ARD must be 500 μ s or more.
- This is the time the PTX is waiting for an ACK packet before a retransmit is made. The PTX is in RX mode for a minimum of 250 μ s, but it stays in RX mode to the end of the packet if that is longer than 250 μ s. Then it goes to standby-I mode for the rest of the specified ARD. After the ARD it goes to TX mode and then retransmits the packet.
- The RX_DR IRQ is asserted by a new packet arrival event. The procedure for handling this interrupt should be: 1) read payload through SPI, 2) clear RX_DR IRQ, 3) read FIFO_STATUS to check if there are more payloads available in RX FIFO, 4) if there are more data in RX FIFO, repeat from step 1).
- If ACK packet payload is activated, ACK packets have dynamic payload lengths and the Dynamic Payload Length feature should be enabled for pipe 0 on the PTX and PRX. This is to ensure that they receive the ACK packets with payloads. If the ACK payload is more than 15 byte in 2 Mbps mode the ARD must be 500 μ s or more, and if the ACK payload is more than 5 byte in 1 Mbps mode the ARD must be 500 μ s or more. In 250 kbps mode (even when the payload is not in ACK) the ARD must be 500 μ s or more.

Table 11. Register map of the RF transceiver

4 MCU

The nRF24LE1 contains a fast 8-bit MCU, which executes the normal 8051 instruction set.

The architecture eliminates redundant bus states and implements parallel execution of fetch and execution phases. Most of the one-byte instructions are performed in a single cycle. The MCU uses one clock per cycle. This leads to a performance improvement rate of 8.0 (in terms of MIPS) with respect to legacy 8051 devices.

The original 8051 had a 12-clock architecture. A machine cycle needed 12 clocks and most instructions were either one or two machine cycles. Except for MUL and DIV instructions, the 8051 used either 12 or 24 clocks for each instruction. Each cycle in the 8051 also used two memory fetches. In many cases, the second fetch was a dummy, and extra clocks were wasted.

[Table 12.](#) shows the speed advantage compared to a legacy 8051. A speed advantage of 12 implies that the instruction is executed twelve times faster. The average speed advantage is 8.0. However, the real speed improvement seen in any system depends on the instruction mix.

Speed advantage	Number of instructions	Number of opcodes
24	1	1
12	27	83
9.6	2	2
8	16	38
6	44	89
4.8	1	2
4	18	31
3	2	9
Average: 8.0	Sum: 111	Sum: 255

Table 12. Speed advantage summary

4.1 Block diagram

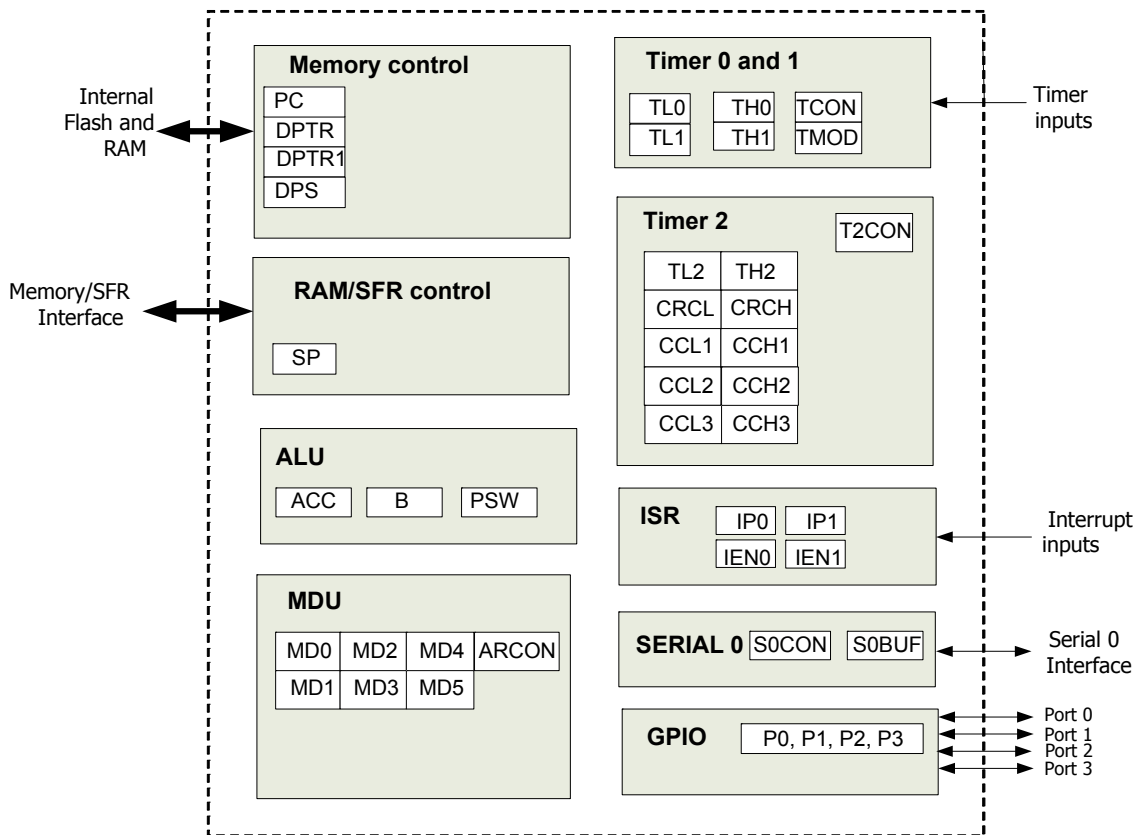

Figure 29. MCU block diagram

4.2 Features

- Control Unit
 - ▶ 8-bit instruction decoder
 - ▶ Reduced instruction cycle time (up to 12 times in respect to standard 80C51)
- Arithmetic-Logic Unit
 - ▶ 8-bit arithmetic and logical operations
 - ▶ Boolean manipulations
 - ▶ 8 x 8 bit multiplication and 8 / 8 bit division
- Multiplication-Division Unit
 - ▶ 16 x 16 bit multiplication
 - ▶ 32 / 16 bit and 16 / 16 bit division
 - ▶ 32-bit normalization
 - ▶ 32-bit L/R shifting
- Three 16-bit Timers/Counters
 - ▶ 80C51-like Timer 0 & 1
 - ▶ 80515-like Timer 2
- Compare/Capture Unit, dedicated to Timer 2
 - ▶ Software control capture
- Full Duplex Serial Interfaces
 - ▶ Serial 0 (80C51-like)
 - ▶ Synchronous mode, fixed baud rate

- ▶ 8-bit UART mode, variable baud rate
- ▶ 9-bit UART mode, fixed baud rate
- ▶ 9-bit UART mode, variable baud rate
- ▶ Baud Rate Generator
- Interrupt Controller
 - ▶ Four Priority Levels with 13 interrupt sources
- Memory interface
 - ▶ 16-bit address bus
 - ▶ Dual Data Pointer for fast data block transfer
- Hardware support for software debug

4.3 Functional description

4.3.1 Arithmetic Logic Unit (ALU)

The Arithmetic Logic Unit (ALU) provides 8-bit division, 8-bit multiplication, and 8-bit addition with or without carry. The ALU also provides 8-bit subtraction with borrow and some bitwise logic operations, that is, logical AND, OR, Exclusive OR or NOT.

All operations are unsigned integer operations. Additionally, the ALU can increment or decrement 8-bit registers. For accumulator only, it can rotate left or right through carry or not, swap nibbles, clear or complement bits and perform a decimal adjustment.

The ALU is handled by three registers, which are memory mapped as special function registers. Operands for operations may come from accumulator `ACC`, register `B` or from outside of the unit. The result may be stored in accumulator `ACC` or may be driven outside of the unit. The control register, that contains flags such as carry, overflow or parity, is the `PSW` (Program Status Word) register.

The nRF24LE1 also contains an on-chip co-processor MDU (Multiplication Division Unit). This unit enables 32-bit division, 16-bit multiplication, shift and normalize operations, see [chapter 14 on page 124](#) for details.

4.3.2 Instruction set summary

All instructions are binary code compatible and perform the same functions as they do within the legacy 8051 processor. The following tables give a summary of the instruction set with the required corresponding clock cycles.

Mnemonic	Description	Code	Bytes	Cycles
ADD A,Rn	Add register to accumulator	0x28-0x2F	1	1
ADD A,direct	Add directly addressed data to accumulator	0x25	2	2
ADD A,@Ri	Add indirectly addressed data to accumulator	0x26-0x27	1	2
ADD A,#data	Add immediate data to accumulator	0x24	2	2
ADDC A,Rn	Add register to accumulator with carry	0x38-0x3F	1	1
ADDC A, direct	Add directly addressed data to accumulator with carry	0x35	2	2
ADDC A,@Ri	Add indirectly addressed data to accumulator with carry	0x36-0x37	1	2
ADDC A,#data	Add immediate data to accumulator with carry	0x34	2	2
SUBB A,Rn	Subtract register from accumulator with borrow	0x98-0x9F	1	1
SUBB A, direct	Subtract directly addressed data from accumulator with borrow	0x95	2	2
SUBB A, @Ri	Subtract indirectly addressed data from accumulator with borrow	0x96-0x97	1	2
SUBB A, #data	Subtract immediate data from accumulator with borrow	0x94	2	2
INC A	Increment accumulator	0x04	1	1

Mnemonic	Description	Code	Bytes	Cycles
INC Rn	Increment register	0x08-0x0F	1	2
INC direct	Increment directly addressed location	0x05	2	3
INC @Ri	Increment indirectly addressed location	0x06-0x07	1	3
INC DPTR	Increment data pointer	0xA3	1	1
DEC A	Decrement accumulator	0x14	1	1
DEC Rn	Decrement register	0x18-0x1F	1	2
DEC direct	Decrement directly addressed location	0x15	2	3
DEC @Ri	Decrement indirectly addressed location	0x16-0x17	1	3
MUL AB	Multiply A and B	0xA4	1	5
DIV	Divide A by B	0x84	1	5
DA A	Decimal adjust accumulator	0xD4	1	1

Table 13. Arithmetic operations

Mnemonic	Description	Code	Bytes	Cycles
ANL A, Rn	AND register to accumulator	0x58-0x5F	1	1
ANL A,direct	AND directly addressed data to accumulator	0x55	2	2
ANL A,@Ri	AND indirectly addressed data to accumulator	0x56-0x57	1	2
ANL A,#data	AND immediate data to accumulator	0x54	2	2
ANL direct,A	AND accumulator to directly addressed location	0x52	2	3
ANL direct,#data	AND immediate data to directly addressed location	0x53	3	4
ORL A,Rn	OR register to accumulator	0x48-0x4F	1	1
ORL A,direct	OR directly addressed data to accumulator	0x45	2	2
ORL A,@Ri	OR indirectly addressed data to accumulator	0x46-0x47	1	2
ORL A,#data	OR immediate data to accumulator	0x44	2	2
ORL direct,A	OR accumulator to directly addressed location	0x42	2	3
ORL direct,#data	OR immediate data to directly addressed location	0x43	3	4
XRL A,Rn	Exclusive OR register to accumulator	0x68-0x6F	1	1
XRL A, direct	Exclusive OR indirectly addressed data to accumulator	0x66-0x67	2	2
XRL A,@Ri	Exclusive OR indirectly addressed data to accumulator	0x66-0x67	1	2
XRL A,#data	Exclusive OR immediate data to accumulator	0x64	2	2
XRL direct,A	Exclusive OR accumulator to directly addressed location	0x62	2	3
XRL direct,#data	Exclusive OR immediate data to directly addressed location	0x63	3	4
CLR A	Clear accumulator	0xE4	1	1
CPL A	Complement accumulator	0xF4	1	1
RL A	Rotate accumulator left	0x23	1	1
RLC A	Rotate accumulator left through carry	0x33	1	1
RR A	Rotate accumulator right	0x03	1	1
RRC A	Rotate accumulator right through carry	0x13	1	1
SWAP A	Swap nibbles within the accumulator	0xC4	1	1

Table 14. Logic operations

Mnemonic	Description	Code	Bytes	Cycles
MOV A,Rn	Move register to accumulator	0xE8-0xEF	1	1
MOV A,direct	Move directly addressed data to accumulator	0xE5	2	2
MOV A,@Ri	Move indirectly addressed data to accumulator	0xE6-0xE7	1	2
MOV A,#data	Move immediate data to accumulator	0x74	2	2
MOV Rn,A	Move accumulator to register	0xF8-0xFF	1	2
MOV Rn,direct	Move directly addressed data to register	0xA8-0xAF	2	4
MOV Rn,#data	Move immediate data to register	0x78-0x7F	2	2
MOV direct,A	Move accumulator to direct	0xF5	2	3
MOV direct,Rn	Move register to direct	0x88-0x8F	2	3
MOV direct,direct2	Move directly addressed data to directly addressed location	0x85	3	4
MOV direct,@Ri	Move indirectly addressed data to directly addressed location	0x86-0x87	2	4
MOV direct,#data	Move immediate data to directly addressed location	0x75	3	3
MOV @Ri,A	Move accumulator to indirectly addressed location	0xF6-0xF7	1	3
MOV @Ri,direct	Move directly addressed data to indirectly addressed location	0xA6-0xA7	2	5
MOV @Ri,#data	Move immediate data to indirectly addressed location	0x76-0x77	2	3
MOV DPTR,#data16	Load data pointer with a 16-bit immediate	0x90	3	3
MOVC A,@A+DPTR	Load accumulator with a code byte relative to DPTR	0x93	1	3
MOVC A,@A+PC	Load accumulator with a code byte relative to PC	0x83	1	3
MOVX A,@Ri	Move ^a external RAM (8-bit addr) to accumulator	0xE2-0xE3	1	4
MOVX A,@DPTR	Move ^a external RAM (16-bit addr) to accumulator	0xE0	1	4
MOVX @Ri,A	Move ^a accumulator to external RAM (8-bit addr)	0xF2-0xF3	1	5
MOVX @DPTR,A	Move ^a accumulator to external RAM (16-bit addr)	0xF0	1	5
PUSH direct	Push directly addressed data onto stack	0xC0	2	4
POP direct	Pop directly addressed location from stack	0xD0	2	3
XCH A,Rn	Exchange register with accumulator	0xC8-0xCF	1	2
XCH A,direct	Exchange directly addressed location with accumulator	0xC5	2	3
XCH A,@Ri	Exchange indirect RAM with accumulator	0xC6-0xC7	1	3
XCHD A,@Ri	Exchange low-order nibbles of indirect and accumulator	0xD6-0xD7	1	3

a. The MOVX instructions perform one of two actions depending on the state of pmw bit (pcon.4).

Table 15. Data transfer operations

Mnemonic	Description	Code	Bytes	Cycles
ACALL addr11	Absolute subroutine call	xxx10001b	2	6
LCALL addr16	Long subroutine call	0x12	3	6
RET	Return from subroutine	0x22	1	4
RETI	Return from interrupt	0x32	1	4
AJMP addr11	Absolute jump	xxx00001b	2	3
LJMP addr16	Long jump	0x02	3	4
SJMP rel	Short jump (relative address)	0x80	2	3
JMP @A+DPTR	Jump indirect relative to the DPTR	0x73	1	2
JZ rel	Jump if accumulator is zero	0x60	2	3
JNZ rel	Jump if accumulator is not zero	0x70	2	3
JC rel	Jump if carry flag is set	0x40	2	3
JNC rel	Jump if carry flag is not set	0x50	2	3
JB bit, rel	Jump if directly addressed bit is set	0x20	3	4
JNB bit, rel	Jump if directly addressed bit is not set	0x30	3	4
JBC bit, rel	Jump if directly addressed bit is set and clear bit	0x10	3	4
CJNE A, direct, rel	Compare directly addressed data to accumulator and jump if not equal	0xB5	3	4
CJNE A,#data,rel	Compare immediate data to accumulator and jump if not equal	0xB4	3	4
CJNE Rn, #data, rel	Compare immediate data to register and jump if not equal	0xB8-0xBF	3	4
CJNE @Ri, #data, rel	Compare immediate data to indirect addressed value and jump if not equal	0xB6-B7	3	4
DJNZ Rn, rel	Decrement register and jump if not zero	0xD8-DF	2	3
DJNZ direct, rel	Decrement directly addressed location and jump if not zero	0xD5	3	4
NOP	No operation	0x00	1	1

Table 16. Program branches

Mnemonic	Description	Code	Bytes	Cycles
CLR C	Clear carry flag	0xC3	1	1
CLR bit	Clear directly addressed bit	0xC2	2	3
SETB C	Set carry flag	0xD3	1	1
SETB bit	Set directly addressed bit	0xD2	2	3
CPL C	Complement carry flag	0xB3	1	1
CPL bit	Complement directly addressed bit	0xB2	2	3
ANL C,bit	AND directly addressed bit to carry flag	0x82	2	2
ANL C,/bit	AND complement of directly addressed bit to carry	0xB0	2	2
ORL C,bit	OR directly addressed bit to carry flag	0x72	2	2
ORL C,/bit	OR complement of directly addressed bit to carry	0xA0	2	2
MOV C,bit	Move directly addressed bit to carry flag	0xA2	2	2
MOV bit,C	Move carry flag to directly addressed bit	0x92	2	3

Table 17. Boolean manipulation

4.3.3 Opcode map

Opcode	Mnemonic	Opcode	Mnemonic	Opcode	Mnemonic
00H	NOP	56H	ANL A,@R0	ACH	MOV R4,direct
01H	AJMP addr11	57H	ANL A,@R1	ADH	MOV R5,direct
02H	JUMP addr16	58H	ANL A,R0	AE	MOV R6,direct
03H	RRA	59H	ANL A,R1	AFH	MOV R7,direct
04H	INCA	5AH	ANL A,R2	B0H	ANL C,/bit
05H	INC direct	5BH	ANL A,R3	B1H	ACALL addr11
06H	INC @R0	5CH	ANL A,R4	B2H	CPL bit
07H	INC @R1	5DH	ANL A,R5	B3H	CPLC
08H	INC R0	5EH	ANL A,R6	B4H	CJNE A,#data,rel
09H	INC R1	5FH	ANL A,R7	B5H	CJNE A, direct, rel
0AH	INC R2	60H	JZ rel	B6H	CJNE @R0,#data,rel
0BH	INC R3	61H	AJMP addr11	B7H	CJNE @R1, #data,rel
0CH	INC R4	62H	XRL direct, A	B8H	CJNE R0, #data,rel
0DH	INC R5	63H	XRL direct, #data	B9H	CJNE R1,#data,rel
0EH	INC R6	64H	XRL A, #data	BAH	CJNE R2,#data,rel
0FH	INC R7	65H	XRL A,direct	BBH	CJNE R3,#data,rel
10H	JBC bit, rel	66H	XRLA,@R0	BCH	CJNE R4,#data,rel
11H	ACALL addr11	67H	XRL A,@R1	BDH	CJNE R5,#data,rel
12H	LCALL add r16	68H	XRL A,R0	BEH	CJNE R6,#data,rel
13H	RRC A	69H	XRL A,R1	BFH	CJNE R7,#data,rel
14H	DEC A	6AH	XRL A,R2	C0H	PUSH direct
15H	DEC direct	6BH	XRL A,R3	C1H	AJMP addr11
16H	DEC @R0	6CH	XRL A,R4	C2H	CLR bit
17H	DEC @R1	6DH	XRL A,R5	C3H	CLR C
18H	DEC R0	6EH	XRL A,R6	C4H	SWAP A
19H	DEC R1	6FH	XRL A,R7	C5H	XCH A, direct
1AH	DEC R2	70H	JNZ rel	C6H	XCH A,@R0
1BH	DECR3	71H	ACALL addr11	C7H	XCH A,@R1
1CH	DECR4	72H	ORL C, bit	C8H	XCH A,R0
1DH	DECR5	73H	JMP @A+DPTR	C9H	XCH A,R1
1EH	DECR6	74H	MOV A, #data	CAH	XCH A,R2
1FH	DECR7	75H	MOV direct, #data	CBH	XCHA,R3
20H	JB bit, rel	76H	MOV @R0,#data	CCH	XCH A,R4
21H	AJMP addr11	77H	MOV @R1, #data	CDH	XCH A,R5
22H	RET	78H	MOV R0, #data	CEH	XCH A,R6
23H	RL A	79H	MOV R1, #data	CFH	XCHA,R7
24H	ADD A, #data	7AH	MOV R2, #data	D0H	POP direct
25H	ADD A, direct	7BH	MOV R3, #data	D1H	ACALL addr11
26H	ADD A,@R0	7CH	MOV R4, #data	D2H	SETB bit
27H	ADD A,@R1	7DH	MOV R5, #data	D3H	SETB C
28H	ADD A,R0	7EH	MOV R6, #data	D4H	DAA
29H	ADD A,R1	7FH	MOV R7, #data	D5H	DJNZ direct, rel
2AH	ADD A,R2	80H	SJMP rel	D6H	XCHDA,@R0
2BH	ADD A,R3	81H	AJMP addr11	D7H	XCHD A,@R1
2CH	ADD A,R4	82H	ANL C, bit	D8H	DJNZ R0,rel
2DH	ADD A,R5	83H	MOVC A,@A+PC	D9H	DJNZ R1,rel
2EH	ADD A,R6	84H	DIV AB	DAH	DJNZ R2,rel
2FH	ADD A,R7	85H	MOV direct, direct	DBH	DJNZ R3,rel
30H	JNB bit, rel	86H	MOV direct,@R0	DCH	DJNZ R4,rel
31H	ACALL addr11	87H	MOV direct,@R1	DDH	DJNZ R5,rel

Opcode	Mnemonic	Opcode	Mnemonic	Opcode	Mnemonic
32H	RETI	88H	MOV direct,R0	DE	DJNZ R6,rel
33H	RLC A	89H	MOV direct,R1	DFH	DJNZ R7,rel
34H	ADDC A,#data	8AH	MOV direct,R2	E0H	MOVX A,@DPTR
35H	ADDC A, direct	8BH	MOV direct,R3	E1H	AJMP addr11
36H	ADDC A,@R0	8CH	MOV direct,R4	E2H	MOVX A,@R0
37H	ADDC A,@R1	8DH	MOV direct, R5	E3H	MOVX A,@R1
38H	ADDC A,R0	8EH	MOV direct,R6	E4H	CLR A
39H	ADDC A,R1	8FH	MOV direct,R7	E5H	MOVA, direct
3AH	ADDC A,R2	90H	MOV DPTR, #data16	E6H	MOVA,@R0
3BH	ADDC A,R3	91H	ACALL addr11	E7H	MOV A,@R1
3CH	ADDC A,R4	92H	MOV bit, C	E8H	MOV A,R0
3DH	ADDC A,R5	93H	MOVCA,@A+DPTR	E9H	MOV A,R1
3EH	ADDC A,R6	94H	SUBB A, #data	EAH	MOV A,R2
3FH	ADDC A,R7	95H	SUBB A, direct	EBH	MOV A,R3
40H	JC rel	96H	SUBB A,@R0	ECH	MOV A,R4
41H	AJMP addr11	97H	SUBB A,@R1	EDH	MOV A,R5
42H	ORL direct, A	98H	SUBB A, R0	EEH	MOV A,R6
43H	ORL direct, #data	99H	SUBB A,R1	EFH	MOV A,R7
44H	ORL A, #data	9AH	SUBB A,R2	F0H	MOVX @DPTR,A
45H	ORL A, direct	9BH	SUBB A,R3	F1H	ACALL addr11
46H	ORL A,@R0	9CH	SUBB A,R4	F2H	MOVX @R0,A
47H	ORL A,@R1	9DH	SUBB A,R5	F3H	MOVX @R1,A
48H	ORL A,R0	9EH	SUBB A,R6	F4H	CPL A
49H	ORL A,R1	9FH	SUBB A,R7	F5H	MOV direct, A
4AH	ORL A,R2	A0H	ORL C,/bit	F6H	MOV @R0,A
4BH	ORL A,R3	A1H	AJMP addr11	F7H	MOV @R1,A
4CH	ORL A,R4	A2H	MOV C, bit	F8H	MOV R0,A
4DH	ORL A,R5	A3H	INC DPTR	F9H	MOV R1,A
4EH	ORL A,R6	A4H	MUL AB	FAH	MOV R2,A
4FH	ORL A,R7	A5H	-	FBH	MOV R3,A
50H	JNC rel	A6H	MOV @R0,direct	FCH	MOV R4,A
51H	ACALL addr11	A7H	MOV @R1,direct	FDH	MOV R5,A
52H	ANL direct, A	A8H	MOV R0,direct	FEH	MOV R6,A
53H	ANL direct, #data	A9H	MOV R1,direct	FFH	MOV R7,A
54H	ANL A, #data	AAH	MOV R2,direct		
55H	ANL A, direct	ABH	MOV R3,direct		

Table 18. Opcode map

5 Memory and I/O organization

The MCU has 64 kB of separate address space for code and data, an area of 256 byte for internal data (IRAM) and an area of 128 byte for Special Function Registers (SFR).

The nRF24LE1 memory blocks has a default setting of 16 kB program memory (flash), 1 kB of data memory (SRAM) and 2 blocks (1 kB standard endurance/512 bytes extended endurance) of non-volatile data memory (flash), see default memory map in [Figure 30](#). Read- or write access to the grey areas in this figure may behave unpredictably.

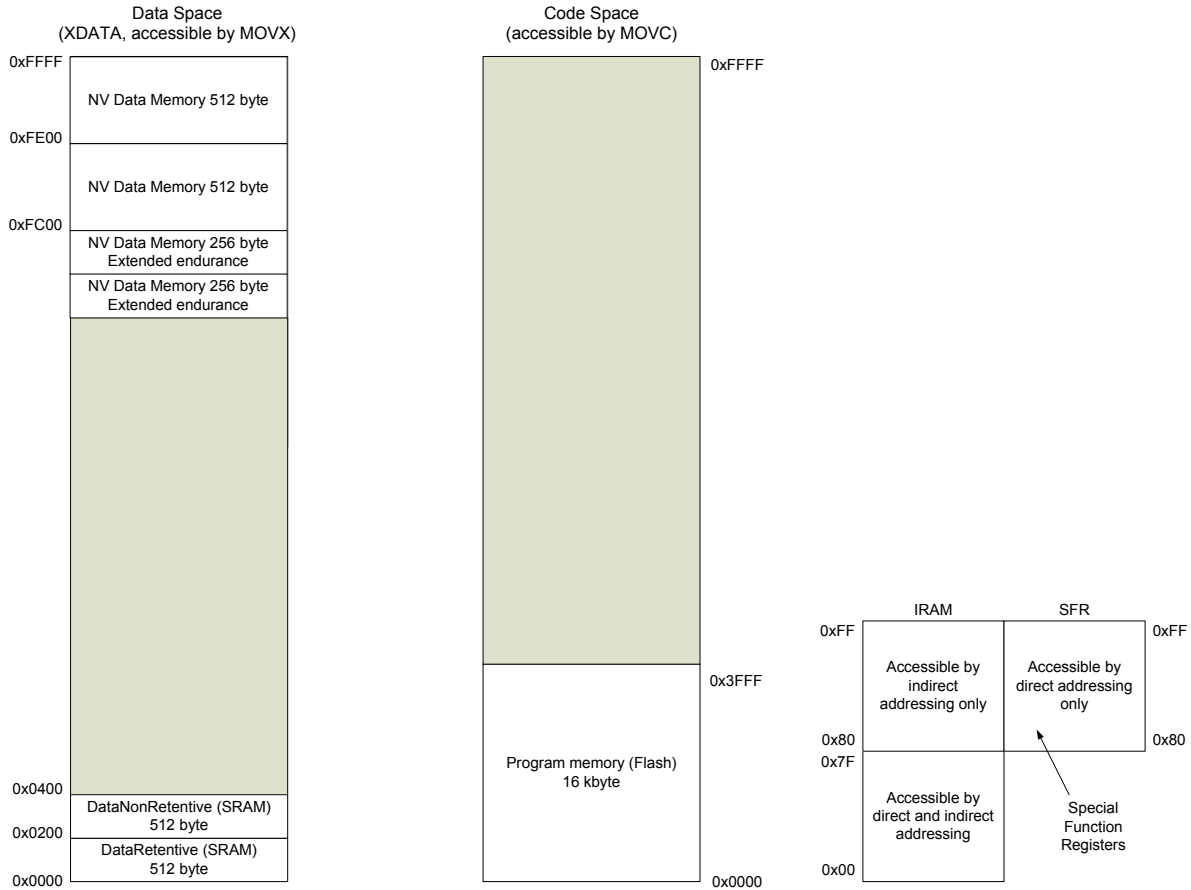

Figure 30. Memory map

The lower 128 bytes of the IRAM contains work registers (0x00 - 0x1F) and bit addressable memory (0x20 - 0x2F). The upper half can only be accessed by indirect addressing.

The lowest 32 bytes of the IRAM form four banks, each consisting of eight registers (R0 - R7). Two bits of the program memory status word (PSW) select which bank is used. The next 16 bytes of memory form a block of bit-addressable memory, accessible through bit addresses 0x00 - 0x7F.

5.1 PDATA memory addressing

The nRF24LE1 supports PDATA (Paged Data memory) addressing into data space. One page (256 bytes) can be accessed by an indirect addressing scheme through registers R0 and R1 (@R0, @R1).

The MPAGE register controls the start address of the PDATA page:

Addr	Bit	R/W	Function	Reset value: 0x00
0xC9	7:0	R/W	Start address of the PDATA page	

Table 19. MPAGE register

MPAGE sets the upper half of the 16 bit address space. For example, setting MPAGE to 0x80 starts PDATA from address 0x8000.

5.2 MCU Special Function Registers

5.2.1 Accumulator - ACC

Accumulator is used by most of the MCU instructions to hold the operand and to store the result of an operation. The mnemonics for accumulator specific instructions refer to accumulator as A, not ACC.

Address	bit7	bit6	bit5	bit4	bit3	bit2	bit1	bit0
0xE0	acc.7	acc.6	acc.5	acc.4	acc.3	acc.2	acc.1	acc.0

Table 20. ACC register

5.2.2 B Register – B

The B register is used during multiplying and division instructions. It can also be used as a scratch-pad register to hold temporary data.

Address	bit7	bit6	bit5	bit4	bit3	bit2	bit1	bit0
0xF0	b.7	b.6	b.5	b.4	b.3	b.2	b.1	b.0

Table 21. B register

5.2.3 Program Status Word Register - PSW

The PSW register contains status bits that reflect the current state of the MCU.

Note: The Parity bit can only be modified by hardware upon the state of ACC register.

Address	Bit	Name	Description
0xD0	7	cy	Carry flag: Carry bit in arithmetic operations and accumulator for Boolean operations.
	6	ac	Auxiliary Carry flag: Set if there is a carry-out from 3rd bit of Accumulator in BCD operations
	5	f0	General purpose flag 0
	4-3	rs	Register bank select, bank 0..3 (0x00-0x07, 0x08-0x0f, 0x10-0x17, 0x18-0x1f)
	2	ov	Overflow flag: Set if overflow in Accumulator during arithmetic operations
	1	f1	General purpose flag 1
	0	p	Parity flag: Set if odd number of '1' in ACC.

Table 22. PSW register

5.2.4 Stack Pointer – SP

This register points to the top of stack in internal data memory space. It is used to store the return address of a program before executing interrupt routine or subprograms. The SP is incremented before executing PUSH or CALL instruction and it is decremented after executing POP or RET(I) instruction (it always points to the top of stack).

Address	Register name
0x81	SP

Table 23. SP register

5.2.5 Data Pointer – DPH, DPL

Address	Register name
0x82	DPL
0x83	DPH

Table 24. Data Pointer register (DPH:DPL)

The Data Pointer Registers can be accessed through DPL and DPH. The actual data pointer is selected by DPS register.

These registers are intended to hold 16-bit address in the indirect addressing mode used by MOVX (move external memory), MOVC (move program memory) or JMP (computed branch) instructions. They may be manipulated as 16-bit register or as two separate 8-bit registers. DPH holds higher byte and DPL holds lower byte of indirect address.

It is generally used to access external code or data space (for example, MOVC A, @A+DPTR or MOV A, @DPTR respectively).

5.2.6 Data Pointer 1 – DPH1, DPL1

Address	Register name
0x84	DPL1
0x85	DPH1

Table 25. Data Pointer 1 register (DPH1:DPL1)

The Data Pointer Register 1 can be accessed through DPL1 and DPH1. The actual data pointer is selected by DPS register.

These registers are intended to hold 16-bit address in the indirect addressing mode used by MOVX (move external memory), MOVC (move program memory) or JMP (computed branch) instructions. They may be manipulated as 16-bit register or as two separate 8-bit registers. DPH1 holds higher byte and DPL1 holds lower byte of indirect address.

It is generally used to access external code or data space (for example, MOVC A,@A+DPTR or MOV A,@DPTR respectively).

The Data Pointer 1 is an extension to the standard 8051 architecture to speed up block data transfers.

5.2.7 Data Pointer Select Register – DPS

The MCU contains two Data Pointer registers. Both of them can be used as 16-bits address source for indirect addressing. The DPS register serves for selecting active data pointer register.

Address	Bit	Name	Description
0x92	7:1	-	Not used
	0	dps	Data Pointer Select. 0: select DPH:DPL, 1: select DPH1:DPL1

Table 26. DPS register

5.2.8 PCON register

The PCON register is used to control the Program Memory Write Mode and Serial Port 0 baud rate doubler.

Address	Bit	Name	Description
0x87	7	smod	Serial port 0 baud rate select, see Table 91. on page 151 and Table 93. on page 156 .
	6	gf3	General purpose flag 3
	5	gf2	General purpose flag 2
	4	pmw	Program memory write mode: 1: MOVX instructions will access memory code space 0: MOVX instructions will access memory data space
	3	gf1	General purpose flag 1
	2	gfo	General purpose flag 0
	1	-	Not used. This bit must always be cleared. Always read as 0.
	0	-	Not used. This bit must always be cleared. Always read as 0.

Table 27. PCON register

5.2.9 Special Function Register Map

The map of Special Function Registers is shown in [Table 28](#). Undefined locations must not be read or written.

Address	X000	X001	X010	X011	X100	X101	X110	X111
0xF8-0xFF	FSR	FPCR	FCR	Reserved	SPIMCON0	SPIMCON1	SPIM-STAT	SPIMDAT
0xF0-0xF7	B							
0xE8-0xEF	RFCON	MD0	MD1	MD2	MD3	MD4	MD5	ARCON
0xE0-0xE7	ACC	W2CON1	W2CON0	Reserved	SPIRCON0	SPIRCON1	SPIRSTAT	SPIRDAT
0xD8-0xDF	ADCON	W2SADR	W2DAT	COMP-CON	POFCON	CCPDATIA	CCP-DATIB	CCPDATO
0xD0-0xD7	PSW	ADCCON 3	ADCCON 2	ADCCON1	ADCDATH	ADCDATL	RNGCTL	RNGDAT
0xC8-0xCF	T2CON	MPAGE	CRCL	CRCH	TL2	TH2	WUOPC1	WUOPC0
0xC0-0xC7	IRCON	CCEN	CCL1	CCH1	CCL2	CCH2	CCL3	CCH3
0xB8-0xBF	IEN1	IP1	S0RE LH	Reserved	SPISCON0		SPISSTAT	SPISDAT
0xB0-0xB7	P3	RSTREA S	PWM-CON	RTC2CON	RTC2CMP0	RTC2CMP1	RTC2CPT 00	
0xA8-0xAF	IEN0	IP0	S0RE LL	RTC2CPT0 1	RTC2CPT10	CLKLFC-TRL	OPMCON	WDSV
0xA0-0xA7	P2	PWMDC 0	PWMDC 1	CLKCTRL	PWRDWN	WUCON	INTEXP	MEMCON
0x98-0x9F	S0CON	S0BUF	Reserved	Reserved	Reserved	Reserved	P0CON	P1CON
0x90-0x97	P1	free	DPS	P0DIR	P1DIR	P2DIR	P3DIR	P2CON
0x88-0x8F	TCON	TMOD	TL0	TL1	TH0	TH1	Reserved	P3CON
0x80-0x87	P0	SP	DPL	DPH	DPL1	DPH1	Reserved	

Table 28. Special Function Registers locations

The registers in the X000 column in B register are both byte and bit addressable. The other registers are only byte addressable.

5.2.10 Special Function Registers reset values

Register name	Address	Reset value	Description
ACC	0xE0	0x00	Accumulator
ADCCON1	0xD3	0x00	ADC Configuration Register 1
ADCCON2	0xD2	0x00	ADC Configuration Register 2
ADCCON3	0xD1	0x00	ADC Configuration Register 3
ADCDATAH	0xD4	0x00	ADC Data high byte
ADCDATAH	0xD5	0x00	ADC Data low byte
ARCON	0xEF	0x00	Arithmetic Control Register
B	0xF0	0x00	B Register
CCEN	0xC1	0x00	Compare/Capture Enable Register
CCH1	0xC3	0x00	Compare/Capture Register 1, high byte
CCH2	0xC5	0x00	Compare/Capture Register 2, high byte
CCH3	0xC7	0x00	Compare/Capture Register 3, high byte
CCL1	0xC2	0x00	Compare/Capture Register 1, low byte
CCL2	0xC4	0x00	Compare/Capture Register 2, low byte
CCL3	0xC6	0x00	Compare/Capture Register 3, low byte
CCPDATIA	0xDD	0x00	Encryption/Decryption accelerator Data In Register A
CCPDATIB	0xDE	0x00	Encryption/Decryption accelerator Data In Register B
CCPDATO	0xDF	0x00	Encryption/Decryption accelerator Data Out Register
CLKLFCTRL	0xAD	0x07	32 kHz (CLKLF) control
CLKCTRL	0xA3	0x00	Clock control
COMPCON	0xDB	0x00	Comparator Control Register
CRCH	0xCB	0x00	Compare/Reload/Capture Register, high byte
CRCL	0xCA	0x00	Compare/Reload/Capture Register, low byte
DPH	0x83	0x00	Data Pointer High 0
DPL	0x82	0x00	Data Pointer Low 0
DPH1	0x85	0x00	Data Pointer High 1
DPL1	0x84	0x00	Data Pointer Low 1
DPS	0x92	0x00	Data Pointer Select Register
FCR	0xFA		Flash Command Register
FPCR	0xF9		Flash Protect Configuration Register
FSR	0xF8		Flash Status Register
IEN0	0xA8	0x00	Interrupt Enable Register 0
IEN1	0xB8	0x00	Interrupt Priority Register / Enable Register 1
INTEXP	0xA6	0x01	Interrupt Expander Register
IP0	0xA9	0x00	Interrupt Priority Register 0
IP1	0xB9	0x00	Interrupt Priority Register 1
IRCON	0xC0	0x00	Interrupt Request Control Register
MD0	0xE9	0x00	Multiplication/Division Register 0
MD1	0xEA	0x00	Multiplication/Division Register 1
MD2	0xEB	0x00	Multiplication/Division Register 2
MD3	0xEC	0x00	Multiplication/Division Register 3
MD4	0xED	0x00	Multiplication/Division Register 4
MD5	0xEE	0x00	Multiplication/Division Register 5
MEMCON	0xA7	0x00	Memory Configuration Register
MPAGE	0xC9	0x00	Start address of the PDATA page
OPMCON	0xAE	0x00	Operational Mode Control
P0	0x80	0xFF	Port 0 value
P0CON	0x9E	0x10	Port 0 Configuration Register
P0DIR	0x93	0xFF	Port 0 pin direction control

Register name	Address	Reset value	Description
P1	0x90	0xFF	Port 1 value
P1CON	0x9F	0x10	Port 1 Configuration Register
P1DIR	0x94	0xFF	Port 1 pin direction control
P2	0xA0	0xFF	Port 2 value
P2CON	0x97	0x10	Port 2 Configuration Register
P2DIR	0x95	0xFF	Port 2 pin direction control
P3	0xB0	0xFF	Port 3 value
P3CON	0x8F	0x10	Port 3 Configuration Register
P3DIR	0x96	0xFF	Port 3 pin direction control
POFCON	0xDC	0x00	Power-fail Comparator Configuration Register
PSW	0xD0	0x00	Program Status Word
PWMCON	0xB2	0x00	PWM Configuration Register
PWMDC0	0xA1	0x00	PWM Duty Cycle for channel 0
PWMDC1	0xA2	0x00	PWM Duty Cycle for channel 1
PWRDWN	0xA4	0x00	Power-down control
RFCON	0xE8	0x02	RF Transceiver Control Register
RNGCTL	0xD6	0x40	Random Number Generator Control Register
RNGDAT	0xD7	0x00	Random Number Generator Data Register
RSTREAS	0xB1	0x00	Reset Reason Register
RTC2CMP0	0xB4	0xFF	RTC2 Compare Value Register 0
RTC2CMP1	0xB5	0xFF	RTC2 Compare Value Register 1
RTC2CON	0xB3	0x00	RTC2 Configuration Register
RTC2CPT00	0xB6	0x00	RTC2 Capture Value Register 00
RTC2CPT01	0xAB	0x00	RTC2 Capture Value Register 01
RTC2CPT10	0xAC	0x00	RTC2 Capture Value Register 10
S0BUF	0x99	0x00	Serial Port 0, Data Buffer
S0CON	0x98	0x00	Serial Port 0, Control Register
S0RELH	0xBA	0x03	Serial Port 0, Reload Register, high byte
S0RELL	0xAA	0xD9	Serial Port 0, Reload Register, low byte
SP	0x81	0x07	Stack Pointer
SPIMCON0	0xFC	0x02	SPI Master Configuration Register 0
SPIMCON1	0xFD	0x0F	SPI Master Configuration Register 1
SPIMDAT	0xFF	0x00	SPI Master Data Register
SPIMSTAT	0xFE	0x03	SPI Master Status Register
SPIRCON0	0xE4	0x01	RF Transceiver SPI Master Configuration Register 0
SPIRCON1	0xE5	0x0F	RF Transceiver SPI Master Configuration Register 1
SPIRDAT	0xE7	0x00	RF Transceiver SPI Master Data Register
SPIRSTAT	0xE6	0x03	RF Transceiver SPI Master Status Register
SPISCON0	0xBC	0xF0	SPI Slave Configuration Register 0
SPISDAT	0xBF	0x00	SPI Slave Data Register
SPISSTAT	0xBE	0x03	SPI Slave Status Register
T2CON	0xC8	0x00	Timer 2 Control Register
TCON	0x88	0x00	Timer/Counter Control Register
TH0	0x8C	0x00	Timer 0, high byte
TH1	0x8D	0x00	Timer 1, high byte
TH2	0xCD	0x00	Timer 2, high byte
TL0	0x8A	0x00	Timer 0, low byte
TL1	0x8B	0x00	Timer 1, low byte
TL2	0xCC	0x00	Timer 2, low byte
TMOD	0x89	0x00	Timer Mode Register
W2CON0	0xE2	0x80	2-Wire Configuration Register 0

Register name	Address	Reset value	Description
W2CON1	0xE1	0x00	2-Wire Configuration Register 1/Status Register
W2DAT	0xDA	0x00	2-Wire Data Register
W2SADR	0xD9	0x00	2-Wire Slave Address Register
ADCON	0xD8	0x00	Serial Port 0 Baud Rate Select register (only adcon.7 bit used)
WDSW	0xAF	0x00	Watchdog Start Value Register
WUCON	0xA5	0x00	Wakeup configuration register
WUOPC0	0xCF	0x00	Wakeup On Pin Configuration Register 0
WUOPC1	0xCE	0x00	Wakeup On Pin Configuration Register 1

Table 29. Special Function Registers reset values

6 Flash memory

This section describes the operation of the embedded flash memory. MCU can read and write the memory and under special circumstances the MCU can also perform erase and write operations, for instance, when performing a firmware upgrade.

The Flash memory is configured and programmed through an external SPI slave interface. After programming, read and write operations from the external interfaces can be disabled for code protection.

6.1 Features

- 16 kB code memory
- 1k NV data memory
- Page size 512 bytes for NV data memory and program memory
- Two pages of 256 bytes each for extended endurance memory
- 32 pages of main block + 1 InfoPage
- Endurance minimum 1000 write/erase cycles
- Extended endurance memory, minimum 20000 write/erase cycles
- Direct SPI programmable
- Configurable MCU write protection
- Readback protection
- HW support for FW upgrades

6.2 Block diagram

The Flash block in nRF24LE1 is split in 16 kB of generic code space memory and 1.5 kB of Non Volatile data memory.

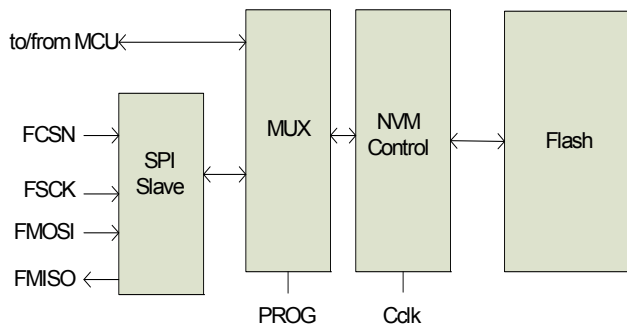

Figure 31. nRF24LE1 Flash block diagram

6.3 Functional description

The Flash block gives the MCU its code space for program storage and NVM space for storing of application data. Two pages of 256 bytes each of the NVM memory have extended endurance and can be erased/written a minimum of 20000 times as opposed to 1000 for the 'normal' flash based NVM. The different parts of the memory can be accessed by the MCU through normal code and data space operations.

Configuration and setup of the memory behavior during normal mode (that is, when MCU is running application code) is defined by data stored in a separate InfoPage. During the chip reset/start-up sequence the configuration data in the InfoPage is read and stored in the memory configuration SFR's.

6.3.1 Using the NV data memory

The 1.5 kB NV memory is divided into two 256-byte extended endurance pages and two 512 byte normal endurance pages. [Table 30.](#) shows the mapping of those four pages for MCU access, SPI access and the page number used for erase (both MCU and SPI).

Data memory area	MCU address	SPI address	Page no.
Extended endurance data	0xFA00 - 0xFAFF	NA	32
	0xFB00 - 0xFBFF	NA	33
Normal endurance data	0xFC00 - 0xFDFF	0x4400 - 0x45FF	34
	0xFE00 - 0xFFFF	0x4600 - 0x47FF	35

Table 30. Mapping for MCU access, SPI access and page number for erase

The NV data memory is read/written as normal flash as described in [section 6.3.3 on page 76](#), except that when writing the NV memory the PMW bit in the PCON register must be cleared. When writing/reading the XDATA memory addresses must be used. In order to erase a NV data memory page, the corresponding flash page address (32 - 35) must be used. Note that a NV data memory byte can only be written once for every page erase. The memory mapping for the NV data memory is illustrated in [Figure 30. on page 62](#).

6.3.2 Flash memory configuration

The on-chip flash memory is divided into 2 blocks, the 16 kB + 1.5 kB NVM main block (MB) and a 512 byte Information Page (IP).

The memory configuration is stored in the InfoPage (IP) and the following configuration can be done:

1. Split the code space of the main block into 2 areas, protected and unprotected (against MCU erase/write operations).
2. Disable Read and Write access to the flash from external interfaces SPI and HW debug.
3. Enable HW debug features.

All configuration of the flash memory must be done through the external SPI interface. The configuration information is stored in the InfoPage during programming of the device and is read out to the flash configuration SFR's during each reset/startup sequence of the circuit.

6.3.2.1 InfoPage content

The InfoPage is a separate page (512 bytes) of flash memory that contains Nordic system tuning parameters and the configurable options of the flash memory. Any changes to the flash memory configuration must be done by updating this page. The InfoPage content is as follows:

InfoPage data	Name	Size	Address	Comment
Device system	DSYS ^a	32 bytes	0x00	Reserved for device use. Do not erase or modify.
Number of unprotected pages: NUPP (page address of start of protected area)	NUPP	1 byte	0x20	Read out to register FPCR during start up NUPP=0xFF: all pages are unprotected
Reserved	-	2 bytes	0x21	Reserved, must be 0xFF
Flash main block read back protect	RDISMB	1 byte	0x23	Disable flash main block access from external interfaces (SPI, HW debug). Byte value: <ul style="list-style-type: none"> • 0xFF: Flash main block accessible from external interfaces • Other value: No read/erase/write of flash main block from external interfaces. Only read of info page Can only be changed once by SPI command RDISMB. Can only be reset by SPI command ERASE ALL
Enable HW debug	ENDE-BUG	1 byte	0x24	Enable on chip HW debug features and JTAG interface. Byte value: <ul style="list-style-type: none"> • 0xFF: HW debug features disabled • other value: HW debug features and JTAG interface enabled
Reserved	-	219 bytes	0x25	Reserved, must be 0xFF
For user data		256 bytes	0x100	Free to use

a. **NOTE:** This InfoPage area is used to store nRF24LE1 system and tuning parameters. Erasing the content of this area WILL cause changes to device behavior and performance.

Table 31. InfoPage content

DSYS - Device System parameters

This InfoPage area is used by the nRF24LE1 to store core data like tuning parameters. Erasing and/or changing this area will cause severe changes to device behavior.

The operations that can affect this area are SPI commands ERASE ALL, ERASE PAGE and PROGRAM operations to any of these flash addresses with the bit INFEN in register FSR set to logic 1.

If you are going to utilise the ERASE ALL SPI command the content of this InfoPage area must be read out, stored and written back into nRF24LE1 after the ERASE ALL command finishes.

Protected pages and data pages

The flash area can be split into a unprotected and a protected area. Protecting an area of the flash means that the area is read only for the MCU, but it can still be read, erased and written by the SPI interface. The feature protects a part of the code space against illegal erase/write operations from the MCU. The protected area can typically be used for firmware upgrade functions (see [section 6.3.6 on page 81](#)).

The code space area of the flash main block is divided into 32 pages with 512 bytes page size. Leaving this byte unchanged (NUPP=0xFF) will leave all the 32 pages of the code space unprotected, i.e. the MCU can erase and write to any section of it. If a number <32 is put in NUPP, the code space of the flash main block will be split in a number of unprotected (= NUPP) and protected pages (31-NUPP). The number put in NUPP is the page number of the first protected page. For example, NUPP=12 gives 12 unprotected pages (0-11) and 20 protected pages (12-31). Please see [Figure 32](#).

If you have split the flash main block in 2, the value of the STP bit in the FSR register will decide where the MCU starts code execution from. In the normal case STP is logic 0 and the code execution will start at code space address 0x0000. If STP is set to logic 1 the code execution will start from the start of the protected area. The STP bit is set during the reset/start up sequence and will be set to logic 1 if there are an odd number of ones in the 16 topmost addresses of the flash data memory. See [Figure 32](#).

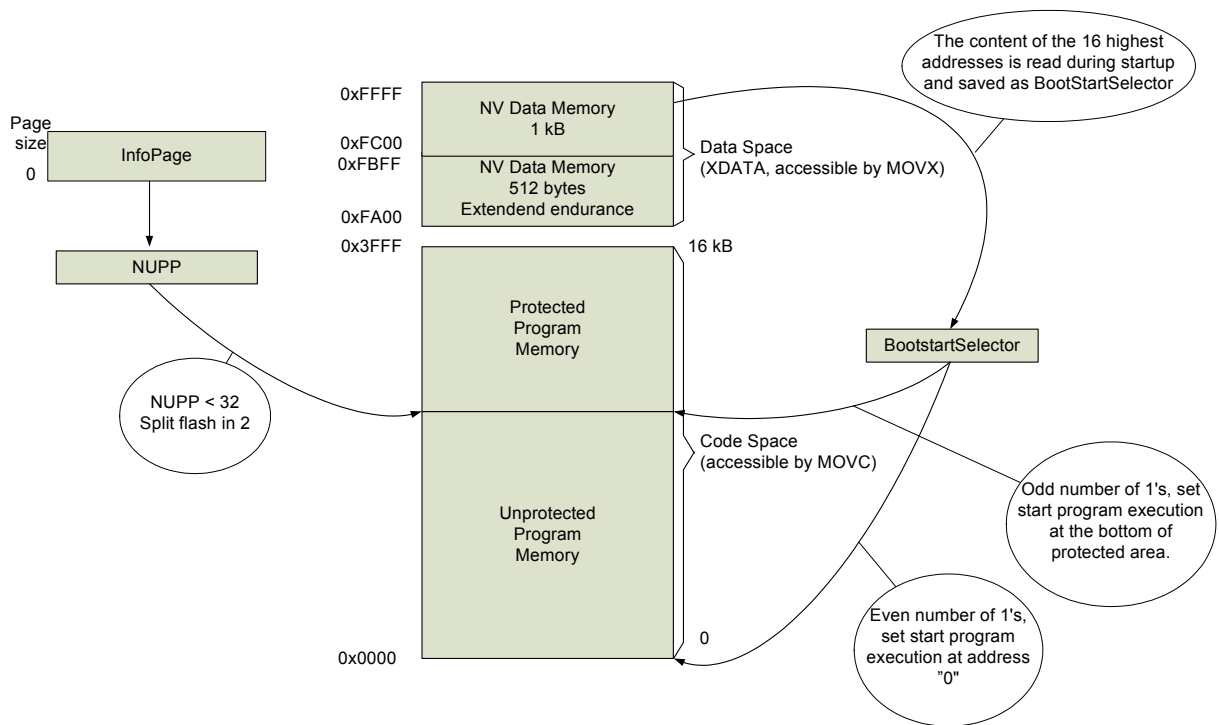

Figure 32. Flash main block protected area

Such a trigger to enable code execution from protected memory might seem cumbersome, but it is made so to ensure safe code execution during firmware upgrades. Please see [chapter 27 on page 185](#) for further details.

RDISMB - Read DISable Main Block

By changing this byte from 0xFF the SPI and other external interfaces no longer have any access to the flash main block and only read access to the InfoPage.

The byte is changed by the RDISMB SPI command and since it cuts the SPI access to the flash main block, must be the last command sent to a nRF24LE1 during flash programming. The only SPI command that can give SPI access to the flash again is ERASE ALL.

Note: ERASE ALL will also erase the entire InfoPage. Using ERASE ALL without first reading out and store InfoPage area DSYS for later write back, will render the device non functional!

ENDEBUG - Enable HW debug

Changing this byte from 0xFF will enable the on chip HW debug features and the JTAG debug interface. The on chip HW debug features will change device pin out and needs either a nRFprobe™ or FS2 HW debug tools to be utilized. Please see [chapter 27 on page 185](#) for more details on HW debug features.

6.3.2.2 Memory configuration SFR

During the boot sequence the content of the flash InfoPage (IP) is transferred to the memory configuration SFR's. The same memory configuration SFR's are used for later interfacing from both SPI and MCU.

Address (hex)	Mnemonic	Bit	Reset value	SPI access	SFR access	Description
0xF8	FSR					Flash Status Register
	ENDEDEBUG	7	0, until read from Flash IP	R/W ^a	R/W	Initial value read from byte ENDEDEBUG in flash IP. ENDEDEBUG: 0: HW debug features disabled 1: HW debug features enabled When RDISMB=0, ENDEDEBUG may be set directly by SFR write, but it can not be cleared by SFR.
	STP	6	0, until calculated from 16 MSB flash in NVM	R	R	Enable code execution start from protected flash area (page address NUPP) STP: 0: Even number of logic 1 in 16 MSB of NVM 1: Odd number of logic 1 in 16 MSB of NVM
	WEN	5	0	R/W	R/W	Flash write enable latch. Enables flash write/erase operations from external interfaces (SPI and HW debug) WEN will be cleared after each SPI write or erase operation, but not after a MCU operations.
	RDYN	4	1	R	R	Flash ready flag, active low. Will be set when read out of flash IP is completed in the MCU boot sequence
	INFEN	3	0	R/W	R/W	Flash IP Enable Will re-direct general SPI read/write/erase commands from the flash MB to the IP. Except SPI command <code>ERASE ALL</code> , which will erase both MB and IP
	RDISMB	2	1, until read from flash InfoPage	R/W ^a	R	Flash MB readback protection enabled, active low. RDISMB: 0: External interfaces have full access to the flash 1: MB read/write/erase and IP erase/write commands from external interfaces (SPI and HW debug) disabled. Will only be reset after use of SPI command <code>ERASE ALL</code>
	-	1	1	R	R	Reserved

Address (hex)	Mnemonic	Bit	Reset value	SPI access	SFR access	Description
		0	0	R	R/W	Reserved
0xF9	FPCR					Flash Protect Config Register
		7	1	R	R	Reserved
	NUPP	6:0		R	R	Number of unprotected pages. NUPP will contain the page address of the first protected page if used. Note that this setting ($32 > \text{NUPP} \geq 0$) reserves the 16 highest bytes of the 1 kB NV data memory area, regardless of other settings.
0xFA	FCR					Flash Command Register
	Flash command register	7:0	0	-	R/W	A (SFR) write to this register erases the page with address equal to the register value, if value is < 36 . (max page address). Addresses 32-35 will erase data pages.

- a. Can only be written indirectly through InfoPage, by dedicated SPI command, and is ignored by WRSR command.

Table 32. Registers for MCU and SPI for FLASH configuration control

6.3.3 Brown-out

There is an on-chip power-fail brown-out detector, see [chapter 12 on page 117](#), which ensures that any flash memory program or erase access will be ignored when the Power Fail (POF) signal, see [Figure 53. on page 119](#), is active. Both the micro controller and the Flash memory write operation still function according to specification, and any write operation that was started will be completed. Flash erase operations will be aborted. The Power-fail comparator is disabled after startup and can be enabled by setting bit 7 in POFCON (refer to [Table 66. on page 119.](#))

If the supply voltage drops below $\sim 1.7\text{V}$, that is when the Brown-Out Reset (BOR) signal (see [Figure 53.](#)) is active, the chip will be reset. If the power supply rises again before reaching the reset threshold, there will be no reset. In this case, any ongoing erase access will be aborted, possibly in an unsafe way, but a byte program access will not be aborted. In order to have an indication that shows this has happened, one will need to enable the Power Failure interrupt (POFIRQ, see [Table 48 on page 101](#)).

To ensure proper programming of the flash in the cases where power supply may be unreliable, the user should take the following precautions:

- Make sure there is no partial erase.
 - If the device is reset during an erase cycle, always assume that the erase was unsuccessful.
 - If there is no reset, make sure that the erase duration is longer than 20 ms. A sample firmware code for such a check may be found in nRFG SDK.
 - Make sure the data read back from the flash is identical to what is written to flash. The mechanism above will guarantee that the data is safely stored to flash if the value does compare. If the compare fails, the write has been ignored due to a power supply event.
 - Make sure that the time from “Power fail” to “Reset” is longer than one write operation (46 μs) by a sufficient reservoir on the supply.

6.3.4 Flash programming from the MCU

This section describes how you can write and erase the flash memory using the MCU.

6.3.4.1 MCU write and erase operations in the main block

When a flash write is initiated, the MCU is halted for 740 clock cycles (46µs @16 MHz) for each byte written. When a page erase is initiated, the MCU can be halted for up to 360,000 clock cycles (22.5 ms @16 MHz). During this time the MCU does not respond to any interrupts. Firmware must assure that page erase does not interfere with normal operation of the nRF24LE1.

The MCU can perform erase page and write operations to the unprotected part and the data part of the flash main block. It is required that the clock frequency of the microcontroller system is 16 MHz during flash write operations.

To allow erase and write flash operations the MCU must run the following sequence:

1. Set `WEN` (bit 5) in the `FSR` register high to enable flash erase/write access. The flash is now open for erase and write from the MCU until `WEN` in `FSR` is set low again.
2. Before updating the flash memory it must be erased. Erase operations can only be performed on whole pages. To erase a page, write page address (range 0-31) to the `FCR` register.
3. Set `PMW` (bit 4) in the `PCON` register high to enable program memory write mode.
4. Programming the flash is done through normal memory write operations from the MCU. Bytes are written individually (there is no auto increment) to the flash using the specific memory address.

When the programming code executes from the flash, erase or write operation is self timed and the CPU stops until the operation is finished. If the programming code executes from the XDATA RAM the code must wait until the operation has finished. This can be done either by polling the `RDYN` bit in the `FSR` register to go low or by a wait loop. Do not set `WEN` low before the write or erase operation is finished. Memory address is identical to the flash address, see [chapter 5 on page 62](#) for memory mapping.

6.3.5 Flash programming through SPI

The on-chip flash is designed to interface a standard SPI device for programming. The interface uses an 8-bit instruction register and a set of instructions/commands to program and configure the flash memory.

6.3.5.1 SPI slave interface

To program the memory the SPI slave interface is used. SPI slave connection to the flash memory is activated by setting pin `PROG` = 1 while the reset pin is kept inactive. After the `PROG` pin is set to 1, apply a pulse on the `RESET` pin (Pull `RESET` pin low for a minimum of 0.2 µs and return to high). Selected nRF24LE1 `GPIO` pins are automatically configured as a SPI slave as shown in [Table 33](#). Further information on SPI slave timing can be found in [chapter 18 on page 147](#).

	24pin-4×4	32pin-5×5	48pin-7×7
FCSN	P0.5	P1.1	P2.0
FMISO	P0.4	P1.0	P1.6
FMOSI	P0.3	P0.7	P1.5
FSSCK	P0.2	P0.5	P1.2

Table 33. Flash SPI slave physical interface for each nRF24LE1 package alternative

Note: After activation of the `PROG` pin you must wait at least 1.5 ms before you input the first flash command.

The program interface uses an 8 bit instruction register and a set of commands to program and configure the flash memory.

Command	Command format	Address	# Data bytes	Command operation
WREN	0x06	NA	0	Set flash write enable latch. Bit WEN register FSR
WRDIS	0x04	NA	0	Reset flash write enable latch. Bit WEN in register FSR
RDSR	0x05	NA	1	Read FLASH Status Register (FSR)
WRSR	0x01	NA	1	Write FLASH Status Register (FSR). Note: The DBG bit in FSR can only be set by the MCU
READ	0x03	2 bytes, First flash address to be read	1-18432	Read data from FLASH
PROGRAM	0x02	2 bytes, first flash address to be written	1-1024	Write data to FLASH Note: WEN must be set.
ERASE PAGE	0x52	1 byte	0	Erase addressed page Note: WEN must be set.
ERASE ALL	0x62 ^a	NA	0	Erase all pages in FLASH main block and infopage. When FSR.INFEN is low, only the main block is erased. When FSR.INFEN=1, both the main block and Info Page are erased. Note: WEN must be set.
RDFPCR	0x89	NA	1	Read FLASH Protect Configuration Register FPCR
RDISMB	0x85	NA	0	Enable Flash readback protection Note: WEN must be set
ENDEBUG	0x86	NA	0	Enable HW debug features Note: WEN must be set. Operation can only be done once

a. **NOTE:** The InfoPage area DSYS are used to store nRF24LE1 system and tuning parameters. Erasing the content of this area WILL cause changes to device behavior and performance. InfoPage area DSYS should ALWAYS be read out and stored prior to using [ERASE ALL](#). Upon completion of the erase the DSYS information must be written back to the flash InfoPage.

Table 34. Flash operation commands

The signalling of the SPI interface is shown in [Figure 33.](#) and [Figure 34.](#)

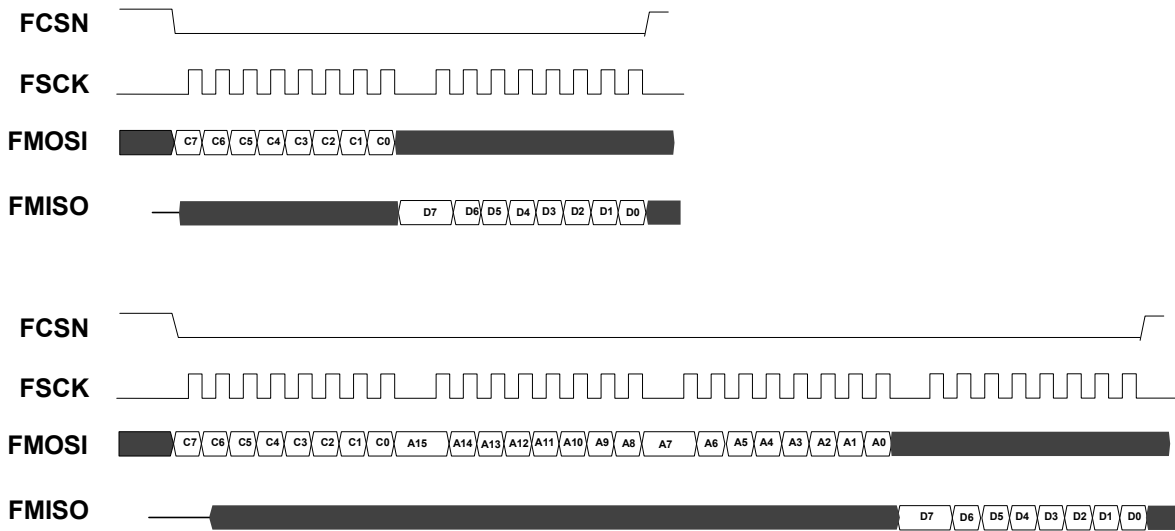

Figure 33. SPI read operation for direct and addressed command

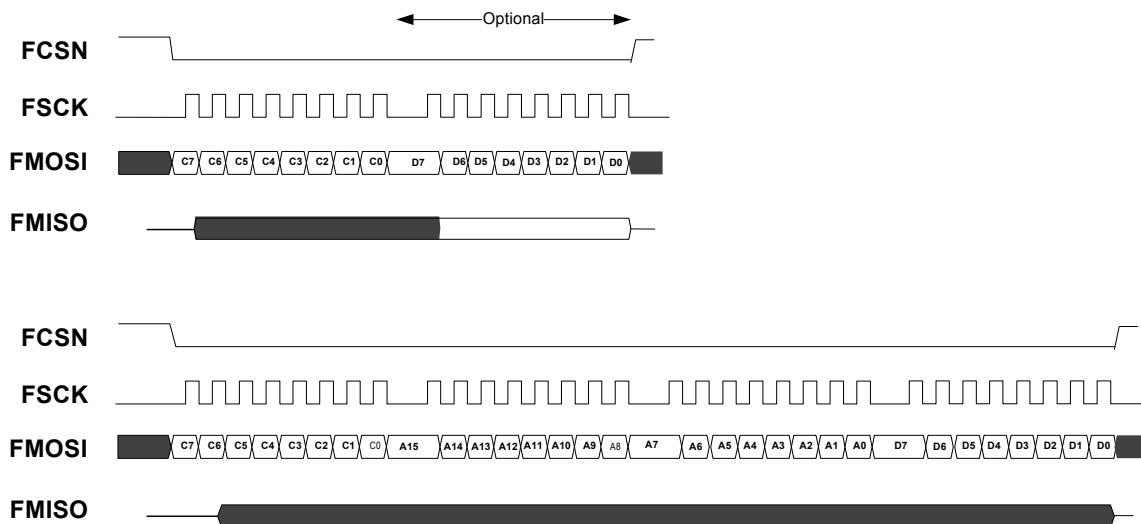

Figure 34. SPI write operations for direct and addressed commands

Abbreviations	Description
Cx	SPI Command bit
Ax	Flash address. Sequence MS to LS byte, MS to LS bit.
Dx	SPI data bit, Sequence LS to MS byte, MS to LS bit. Presence depending on SPI command.

Table 35. Flash SPI interface signal abbreviations

WREN / WRDIS flash write enable/disable:

SPI commands [WREN](#) and [WRDIS](#) sets and resets the flash write enable latch WEN in register FSR. This latch enables all write and erase operations in the flash blocks.

The device will power-up in write disable state, and automatically go back to write disable state after each write/erase SPI command (FCSN set high). Each erase and write command over the SPI interface must therefore be preceded by a WREN command.

Both `WREN` and `WRDIS` are 1-byte SPI commands with no data.

RDSR / WRSR read/write flash status register

SPI commands `RDSR` and `WRSR` read and writes to the flash status register FSR. Both commands are 1 and are followed by a data byte for the FSR content, see [Figure 33](#), and [Figure 34](#).

READ

SPI command `READ` reads out the content of an addressed position in the flash main block. It must be followed by 2 bytes denoting the start address of the read operation, see [Figure 33](#). If bit `INFEN` in register FSR is enabled, the read operation will be conducted from the InfoPage instead.

If the FCSN line is kept active after the first data byte is read out the read command can be extended, the address is auto incremented and data continues to shift out. The internal address counter rolls over when the highest address is reached, allowing the complete memory to be read in one continuous read command.

A read back of the flash main block content is only possible if the read disable bit `RDISMB` in the FSR register is not set.

PROGRAM

SPI command `PROGRAM`, programs the content of the addressed position in the flash main block. It must be followed by 2 bytes denoting the start address of the write operation, see [Figure 34](#). If bit `INFEN` in register FSR is enabled, the write operation will access the InfoPage instead.

Before each write operation the write enable latch WEN must be enabled through the WREN SPI command. It is possible to write up to 1 kB (two pages) in one `PROGRAM` command. The first byte can be anywhere in a page. A byte can not be reprogrammed without erasing the whole sector.

The device automatically returns to flash write disable (`WEN=0`) after completion of a `PROGRAM` command (`pin FCSN=1`).

ERASE PAGE

SPI command `ERASE PAGE` erases 1 addressed page (512 bytes) in the flash main block. The command must be followed by a 1 byte page address (0-31 for pages in the code memory, 32-35 for pages in the NVM), see [Figure 34](#).

Before each erase operation the write enable latch WEN must be enabled through the WREN SPI command. The on-chip driven erase sequence is started when the FCSN pin is set high after the `ERASE PAGE` command. During the erase sequence all SPI commands are ignored except the `RDSR` command.

The device automatically returns to flash write disable (WEN=0) after completion of an ERASE PAGE command sequence.

ERASE ALL

SPI command ERASE ALL, erases all pages in flash main block (code space and NVM) and InfoPage. It is a 1 byte SPI command with no data.

Before the erase operation the write enable latch WEN must be enabled through the WREN SPI command. The on-chip erase sequence is started when the FCSN pin is set high after the ERASE ALL command. During the erase sequence all SPI commands are ignored except RDSR.

If infen (bit 3 in FSR) is set high before execution of the ERASE ALL command both the InfoPage and the MainBlock are erased, otherwise only the MainBlock is erased.

The device returns to write disable after completion of an ERASE ALL command.

RDFPCR - Read Flash Protect Configuration register

SPI command RDFPCR reads out the flash protect configuration register (FPCR), which contains the configuration of MCU write protected pages in the flash main block. The command is followed by 1 byte data.

RDISMB - Enable Read DISable of MainBlock)

SPI command RDISMB enables the readback protection of the flash. The command disables all read/erase and write access to the flash main block from any external interface (SPI or HW debug JTAG). It also disabled erase and write operations in the InfoPage, but read InfoPage read operations are still possible. This will protect code and data in the device from being retrieved through the external flash interfaces.

Before the RDISMB command the write enable latch WEN must be enabled through the WREN SPI command. Once the RDISMB command is sent all SPI connection/control of the flash from the SPI interface is lost. It is important that this command is the last one to be sent in a flash programming sequence.

The command is a 1 byte command with no data.

ENDEBUG - Enable DEBUG

SPI command ENDEBUG enables the on chip support for HW debug. It will also enable the HW debug JTAG interface.

Before the operation the write enable latch WEN must be enabled by SPI command WREN. After the HW debug features are enabled, only an ERASE ALL operation on the flash can reset it.

The command is a 1 byte command with no data.

6.3.6 Hardware support for firmware upgrade

When some of the flash memory is configured as MCU write protected (FPCR.NUPP) and nRF24LE1 is restarted from the protected area, the memory mapping actually changes to make FW upgrades safer. [Figure 35](#) shows an example with unprotected and protected area of the flash code space as it will be after programming the flash.

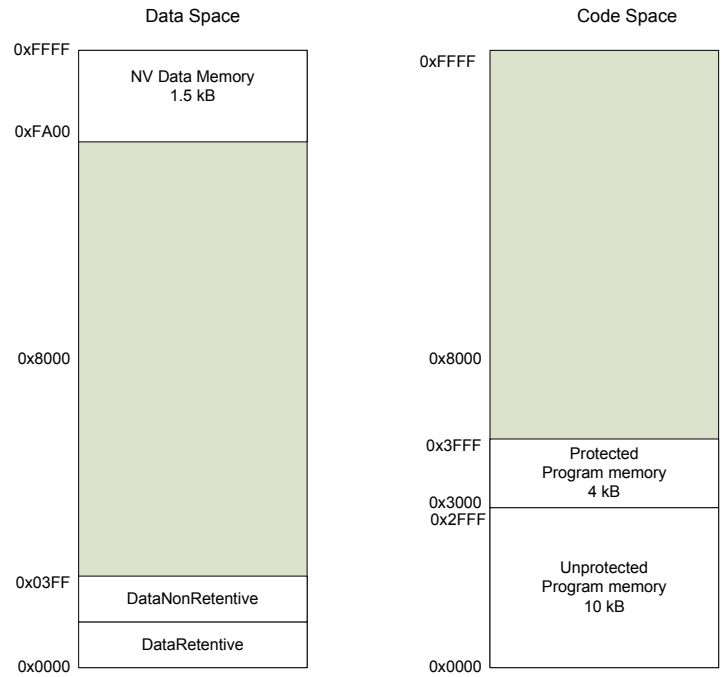

Figure 35. Example memory map with 4 kB of protected flash program memory

After restart address mapping is changed so the protected area now is mapped from address 0x0000 and upwards as shown in [Figure 36](#).

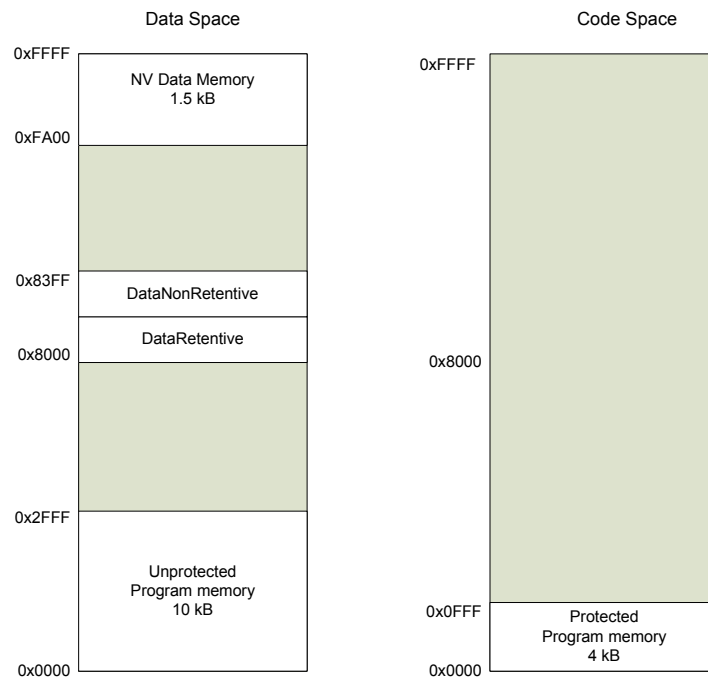

Figure 36. Example memory map with 4 kB of protected flash program memory

The unprotected area is now available in the data space for easy update. Please note that the SRAM blocks in this case is mapped from address 0x8000 independently of MEMCON bit 2. This feature may be used for instance to do a firmware upgrade over air.

Example of use of this mechanism:

- Application is running in unprotected area and the program doing the FW upgrade resides in protected area.
- Communicating device initiates a firmware upgrade over air.
- MCU sets WEN.
- One bit in one of the 16 MS Bytes in the NV Data memory is programmed to 0. Resulting in a odd numbers of logic 1's in this area.
- The system can now be reset, and because of STP it will restart from the protected area.
- Erase and write operations can now be performed safely in the unprotected area.
- In case of a power failure or another reset/restart before the upgrade is finished, the MCU will start execution in the protected area because the number of logic 1's in the 16 MSB of the NVM is not yet changed.
- When the upgrade is finished, another bit in one of the 16 highest addressed bytes is programmed to 0.
- The system can now be restarted, and it will restart from the unprotected area. running the new firmware.

7 Random Access memory (RAM)

The nRF24LE1 contains two separate RAM blocks. These blocks are used to save temporary data or programs.

The MCU internal RAM (IRAM) is the fastest and most flexible, but with only 256 bytes it is very limited.

To accommodate more temporary storage of data or code the nRF24LE1 has an additional 1024x8bit (1kB) SRAM memory block default located in the XDATA address space from address 0x0000 to 0x03FF. The location of the SRAM blocks in the MCU address space can be changed, see [section 7.1](#).

A special feature of the nRF24LE1 SRAM block is that it is composed of two physical 512 byte blocks called DataRetentive (lower 512 bytes) and DataNonRetentive. DataRetentive, in contrast to DataNonRetentive, keeps its memory content during the Memory Retention power down modes (see [chapter 11 on page 105](#)).

7.1 SRAM configuration

It is possible to configure the location in address space of each SRAM block as described in [Figure 37](#).

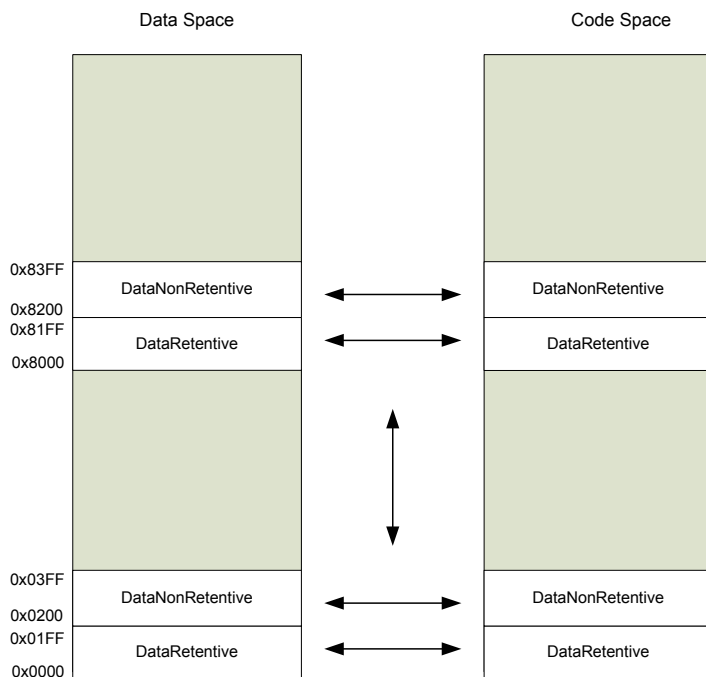

Figure 37. Configurability of SRAM address space location

You can address the SRAM memory blocks both as data and code. The MEMCON register controls this behavior:

Addr	Bit	R/W	Function	Reset value: 0x00
0xA7	7:3	-	Reserved	
	2	R/W	SRAM address location: 0: SRAM blocks start from address 0x0000 1: SRAM blocks start from address 0x8000	
	1	R/W	DataNonRetentive mapping: 0: Mapped as data 1: Mapped as code	
	0	R/W	DataRetentive mapping: 0: Mapped as data 1: Mapped as code	

Table 36. MEMCON register

8 Timers/counters

The nRF24LE1 contains a set of counters used for timing up important system events. One of the timers (RTC2) is also available in power down mode where it can be used as a wakeup source.

8.1 Features

nRF24LE1 includes the following set of timers/counters:

- Three 16-bit timers/counters (Timer 0, Timer 1 and Timer 2) which can operate as either a timer with a clock rate based on the MCU clock, or as an event counter clocked by signals from the programmable digital I/O.
- RTC2 is a configurable, linear, 16-bit real time clock with capture and compare capabilities. Input clock frequency is 32.768 kHz.

8.2 Block diagram

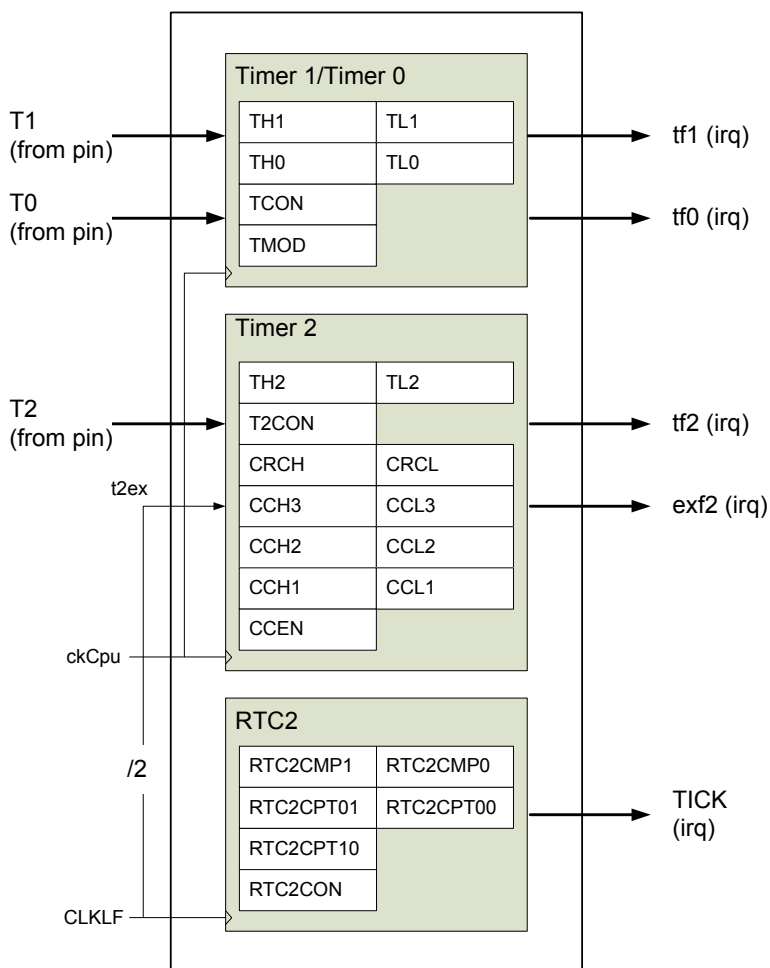

Figure 38. Block diagram of timers/counters

8.3 Functional description

8.3.1 Timer 0 and Timer 1

In timer mode, Timers 0 and 1 are incremented every 12 clock cycles.

In the counter mode, the Timers 0 and 1 are incremented when the falling edge is detected at the corresponding input pin T0 for Timer 0, or T1 for Timer 1.

Note: Timer input pins T0, T1 and, T2 must be configured as described in [section 17.3 on page 135](#).

Since it takes two clock cycles to recognize a 1-to-0 event, the maximum input count rate is $\frac{1}{2}$ of the oscillator frequency. There are no restrictions on the duty cycle, however to ensure proper recognition of 0 or 1 state, an input should be stable for at least 1 clock cycle.

Timer 0 and Timer 1 status and control are in TCON and TMOD register. The actual 16-bit Timer 0 value is in TH0 (8 msb) and TL0 (8 lsb), while Timer 1 uses TH1 and TL1.

Four operating modes can be selected for Timers 0 and 1. Two Special Function Registers, TMOD and TCON, are used to select the appropriate mode.

8.3.1.1 Mode 0 and Mode 1

In mode 0, Timers 0 and 1 are each configured as a 13-bit register (TL0/TL1 = 5 bits, TH0/TH1 = 8 bits). The upper three bits of TL0 and TL1 are unchanged and should be ignored.

In mode 1 Timer 0 is configured as a 16-bit register.

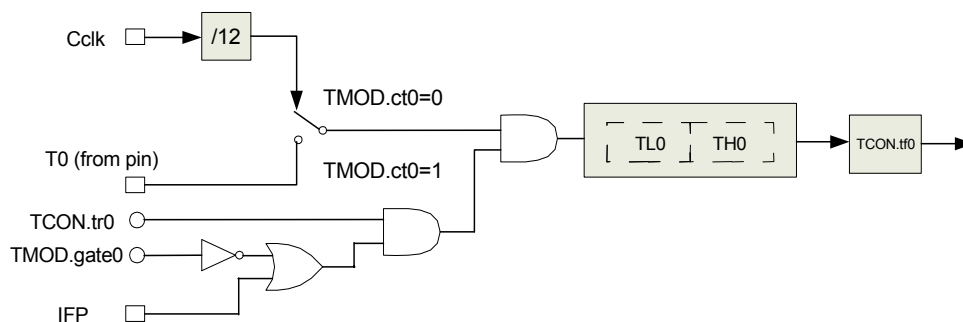

Figure 39. Timer 0 in mode 0 and 1

Likewise, in mode 1, Timer 1 is configured as a 16-bit register.

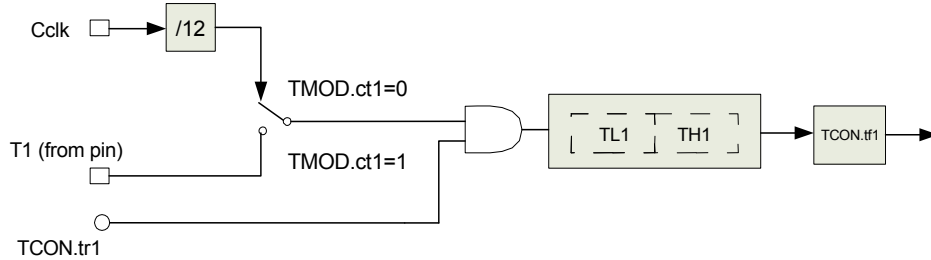

Figure 40. Timer 1 in mode 0 and 1

8.3.1.2 Mode 2

In this mode, Timers 0 and 1 are each configured as an 8-bit register with auto reload.

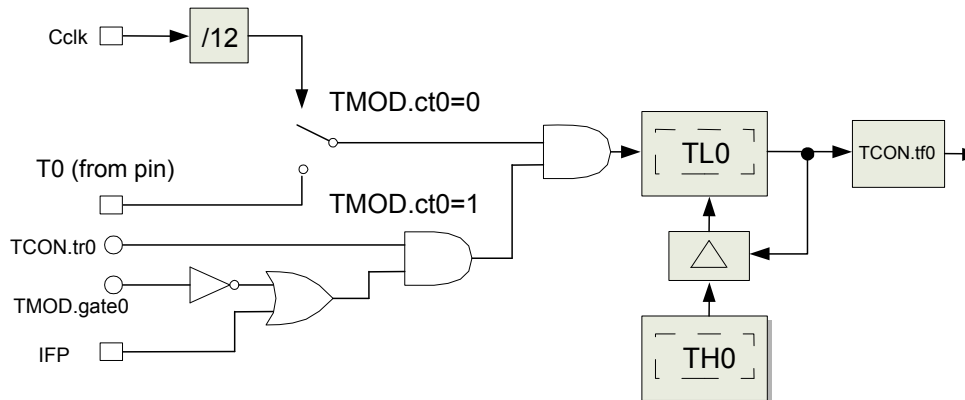

Figure 41. Timer 0 in mode 2

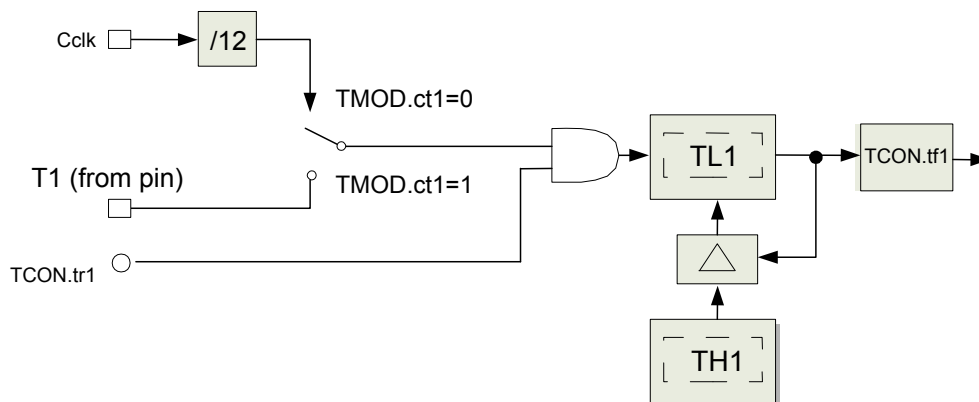

Figure 42. Timer 1 in mode 2

8.3.1.3 Mode 3

In mode 3 Timers 0 and 1 are configured as one 8-bit timer/counter and one 8-bit timer, but timer 1 in this mode holds its count. When Timer 0 works in mode 3, Timer 1 can still be used in other modes by the serial port as a baud rate generator, or as an application not requiring an interrupt from Timer 1.

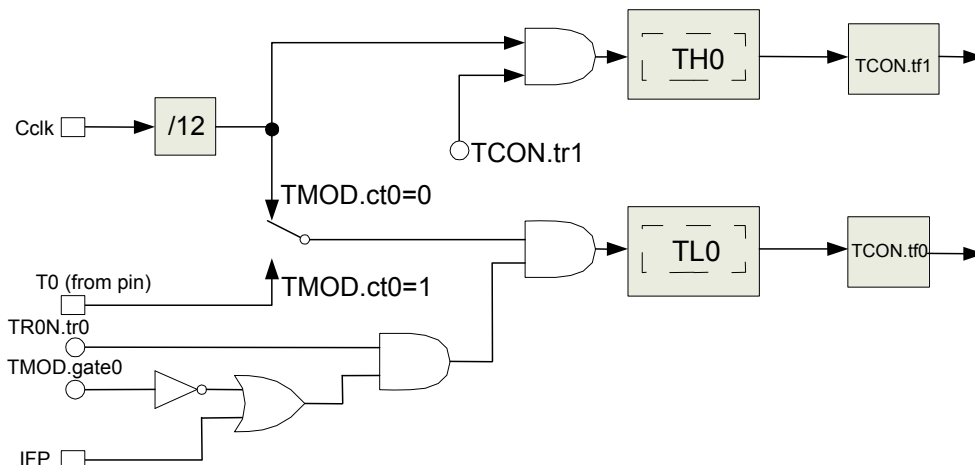

Figure 43. Timer 0 in mode 3

8.3.2 Timer 2

Timer 2 is controlled by `T2CON` while the value is in `TH2` and `TL2`. Timer 2 also has four capture and one compare/reload registers which can read a value without pausing or reload a new 16-bit value when Timer 2 reaches zero, see [chapter 8.4.7 on page 94](#) and [chapter 8.4.8 on page 94](#).

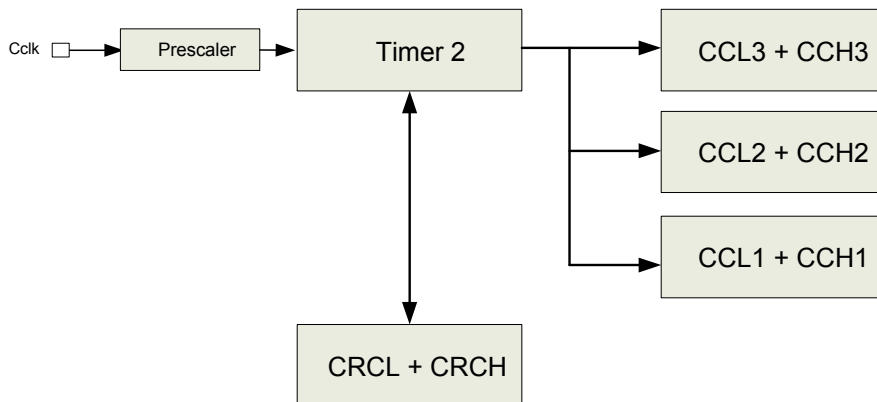

Figure 44. Timer 2 block diagram

8.3.2.1 Timer 2 description

Timer 2 can operate as a timer, event counter, or gated timer.

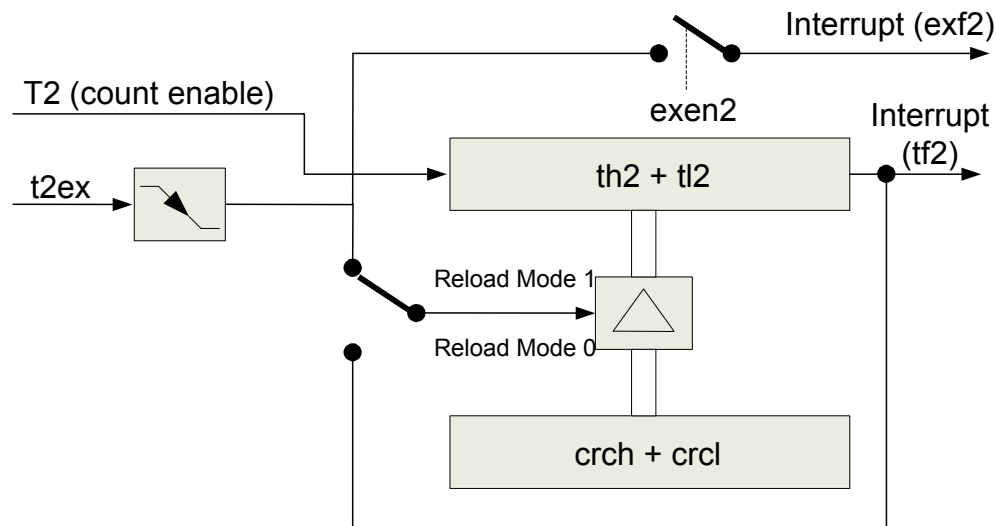

Figure 45. Timer 2 in Reload Mode

8.3.2.2 Timer mode

Timer mode is invoked by setting the $t2i0=1$ and $t2i1=0$ in the `T2CON` register. In this mode, the count rate is derived from the `clk` input.

Timer 2 is incremented every 12 or 24 clock cycles depending on the 2:1 prescaler. The prescaler mode is selected by bit `t2ps` of `T2CON` register. When $t2ps=0$, the timer counts up every 12 clock cycles, otherwise every 24 cycles.

8.3.2.3 Event counter mode

This mode is invoked by setting the $t2i0=0$ and $t2i1=1$ in the `T2CON` register.

In this mode, Timer 2 is incremented when external signal `T2` (see [section 8.4 on page 91](#) for more information on `T2`) changes its value from 1 to 0. The `T2` input is sampled at every rising edge of the clock. Timer 2 is incremented in the cycle following the one in which the transition was detected. The maximum count rate is $\frac{1}{2}$ of the clock frequency.

8.3.2.4 Gated timer mode

This mode is invoked by setting the $t2i0=1$ and $t2i1=1$ in the `T2CON` register.

In this mode, Timer 2 is incremented every 12 or 24 clock cycles (depending on `T2CON t2ps` flag). Additionally, it is gated by the external signal `T2`. When `T2=0`, Timer 2 is stopped.

8.3.2.5 Timer 2 reload

A 16-bit reload from the CRC register can be done in two modes:

- Reload Mode 0: Reload signal is generated by Timer 2 overflow (auto reload).
- Reload Mode 1: Reload signal is generated by negative transition at t2ex.

Note: t2ex is connected to an internal clock signal which is half frequency of CLKLF (see [section 11.3.1 on page 110.](#))

8.4 SFR registers

8.4.1 Timer/Counter control register – TCON

TCON register reflects the current status of MCU Timer 0 and Timer 1 and it is used to control the operation of these modules.

Address	Reset value	Bit	Name	Auto clear	Description
0x88	0x00	7	tf1	Yes	Timer 1 overflow flag. Set by hardware when Timer1 overflows.
		6	tr1	No	Timer 1 Run control. If cleared, Timer 1 stops.
		5	tf0	Yes	Timer 0 overflow flag. Set by hardware when Timer 0 overflows.
		4	tr0	No	Timer 0 Run control. If cleared, Timer 0 stops.
		3	ie1	Yes	External interrupt 1 flag. Set by hardware.
		2	it1	No	External interrupt 1 type control. 1: falling edge, 0: low level
		1	ie0	Yes	External interrupt 0 flag. Set by hardware.
		0	it0	No	External interrupt 0 type control. 1: falling edge, 0: low level

Table 37. TCON register

The tf0, tf1 (Timer 0 and Timer 1 overflow flags), ie0 and ie1 (external interrupt 0 and 1 flags) are automatically cleared by hardware when the corresponding service routine is called.

8.4.2 Timer mode register - TMOD

TMOD register is used for configuration of Timer 0 and Timer 1.

Address	Reset value	Bit	Name	Description
0x89	0x00	7	gate1	Timer 1 gate control
		6	ct1	Timer 1 counter/timer select. 1: Counter, 0: Timer
		5-4	mode1	Timer 1 mode 00 – Mode 0: 13-bit counter/timer 01 – Mode 1: 16-bit counter/timer 10 – Mode 2: 8-bit auto-reload timer 11 – Mode 3: Timer 1 stopped
		3	gate0	Timer 0 gate control
		2	ct0	Timer 0 counter/timer select. 1: Counter, 0: Timer
		1-0	mode0	Timer 0 mode 00 – Mode 0: 13-bit counter/timer 01 – Mode 1: 16-bit counter/timer 10 – Mode 2: 8-bit auto-reload timer 11 – Mode 3: two 8-bit timers/counters

Table 38. TMOD register

8.4.3 Timer 0 – TH0, TL0

Address	Register name
0x8A	TL0
0x8C	TH0

Table 39. Timer 0 register (TH0:TL0)

These registers reflect the state of Timer 0. TH0 holds higher byte and TL0 holds lower byte. Timer 0 can be configured to operate as either a timer or a counter.

8.4.4 Timer 1 – TH1, TL1

Address	Register name
0x8B	TL1
0x8D	TH1

Table 40. Timer 1 register (TH1:TL1)

These registers reflect the state of Timer 1. TH1 holds higher byte and TL1 holds lower byte. Timer 1 can be configured to operate as either timer or counter.

8.4.5 Timer 2 control register – T2CON

T2CON register reflects the current status of Timer 2 and is used to control the Timer 2 operation.

Address	Reset value	Bit	Name	Description
0xC8	0x00	7	t2ps	Prescaler select. 0: timer 2 is clocked with 1/12 of the ckCpu frequency. 1: timer 2 is clocked with 1/24 of the ckCpu frequency.
		6	i3fr	Int3 edge select. 0: falling edge, 1: rising edge
		5	i2fr	Int2 edge select. 0: falling edge, 1: rising edge
		4:3	t2r	Timer 2 reload mode. 0X – reload disabled, 10 – Mode 0, 11 – Mode 1
		2	t2cm	Timer 2 compare mode. 0: Mode 0, 1: Mode 1
		1-0	t2i	Timer 2 input select. 00: stopped, 01: f/12 or f/24, 10: falling edge of T2, 11: f/12 or f/24 gated by T2.

Table 41. T2CON register

8.4.6 Timer 2 – TH2, TL2

Address	Register name
0xCC	TL2
0xCD	TH2

Table 42. Timer 2 (TH2:TL2)

The TL2 and TH2 registers reflect the state of Timer 2. TH2 holds higher byte and TL2 holds lower byte. Timer 2 can be configured to operate in compare, capture or, reload modes.

8.4.7 Compare/Capture enable register – CCEN

The CCEN register serves as a configuration register for the Compare/Capture Unit associated with the Timer 2.

Address	Reset value	Bit	Name	Description
0xC1	0x00	7:6	coca3	compare/capture mode for CC3 register 00: compare/capture disabled 01: reserved 10: reserved 11: capture on write operation into register CCL3
		5:4	coca2	compare/capture mode for CC2 register 00: compare/capture disabled 01: reserved 10: reserved 11: capture on write operation into register CCL2
		3:2	coca1	compare/capture mode for CC1 register 00: compare/capture disabled 01: reserved 10: reserved 11: capture on write operation into register CCL1
		1:0	coca0	compare/capture mode for CRC register 00: compare/capture disabled 01: reserved 10: compare enabled 11: capture on write operation into register CRCL

Table 43. CCEN register

8.4.8 Capture registers – CC1, CC2, CC3

The Compare/Capture registers (CC1, CC2, CC3) are 16-bit registers used by the Compare/Capture Unit associated with the Timer 2. CCHn holds higher byte and CCLn holds lower byte of the CCn register.

Address	Register name
0xC2	CCL1
0xC3	CCH1
0xC4	CCL2
0xC5	CCH2
0xC6	CCL3
0xC7	CCH3

Table 44. Capture Registers - CC1, CC2 and CC3

8.4.9 Compare/Reload/Capture register – CRCH, CRCL

Address	Reset value	Register name
0xCA	0x00	CRCL
0xCB	0x00	CRCH

Table 45. Compare/Reload/Capture register - CRCH, CRCL

CRC (Compare/Reload/Capture) register is a 16-bit wide register used by the Compare/Capture Unit associated with Timer 2. CRCH holds higher byte and CRCL holds lower byte.

8.5 Real Time Clock - RTC

RTC2 contains two registers that can be used for capturing timer values; one loaded at positive edge of the 32.768 kHz clock and another register clocked by the MCU clock for better resolution. Both registers are updated as a consequence of an external event. RTC2 can also give an interrupt at predefined intervals due to value equality between the timer and a compare register. RTC2 ensures that the functions the interrupt is used for are awoken prior to the interrupt.

8.5.1 Features

- 32.768 kHz, sub- μ A.
- 16-bit.
- Linear.
- Compare with IRQ (TICK). Resolution: 30.52 μ s.
- Capture with increased resolution: 125 ns.

8.5.2 Functional description of SFR registers

The following registers control RTC2.

Address (Hex)	Name/Mnemonic	Bit	Reset value	Type	Description
0xB3	RTC2CON	4:0		R/W	RTC2 configuration register.
	<i>sfrCapture</i>	4	0	W	Trigger signal. When the MCU writes a '1' to this register field, RTC2 will capture the timer value. The value is stored in RTC2CPT00 and RTC2CPT01. An additional counter clocked by the MCU clock will at this point contain the number of MCU clock cycles from the previous positive edge of the 32.768 kHz clock (edge detect @ MCU clock). The value is stored in RTC2CPT1.

Address (Hex)	Name/Mnemonic	Bit	Reset value	Type	Description
	<i>enableExternalCapture</i>	3	0	R/W	<p>1: Timer value is captured if required by an IRQ from the Radio (edge detect @ MCU clock). The value is stored in RTC2CPT00 and RTC2CPT01. An additional counter clocked by the MCU clock will at this point contain the number of MCU clock cycles from the previous positive edge of the 32.768 kHz clock (edge detect @ MCU clock). The value is stored in RTC2CPT1.</p> <p>0: Capture by Radio disabled.</p>
	<i>compareMode</i>	2:1	00	R/W	<p>Compare mode.</p> <p>11: The RTC2 IRQ is assigned when the timer value is equal to the concatenation of RTC2CMP1 and RTC2CMP0. RTC2 ensures that the functions for which the IRQ is intended, are all awoken prior to the RTC2 IRQ. When the RTC2 IRQ is assigned, the timer is reset.</p> <p>10: Same as above, except that the RTC2 IRQ will <i>not</i> reset the timer. The timer will always wrap around at overflow.</p> <p>0x: Compare disabled. OK</p>
	<i>rtc2Enable</i>	0	0	R/W	<p>1: RTC2 is enabled. The clock to the RTC2 core functionality is running.</p> <p>0: RTC2 is disabled. The clock to the RTC2 core functionality stands still and the timer is reset.</p>
0xB4	RTC2CMP0	7:0	0xFF	R/W	<p>RTC2 compare value register 0. Contains LSByte of the value to be compared to the timer value to generate RTC2 IRQ. Resolution: 30.52 μs.</p>
0xB5	RTC2CMP1	7:0	0xFF	R/W	<p>RTC2 compare value register 1. Contains MSByte of the value to be compared to the timer value to generate RTC2 IRQ.</p>
0xB6	RTC2CPT00	7:0	0x00	R	<p>RTC2 capture value register 00. Contains LSByte of the timer value at the time of the capture event. Resolution: 30.52 μs.</p>
0xAB	RTC2CPT01	7:0	0x00	R	<p>RTC2 capture value register 01. Contains MSByte of the timer value at the time of the capture event.</p>
0xAC	RTC2CPT10	7:0	0x00	R	<p>RTC2 capture value register 1. Contains the value of the counter that counts the number of MCU clock cycles from the previous positive edge of the 32.768 kHz clock until the capture event. The counter value is truncated by one bit (LSBit). Resolution: 125 ns.</p>

Table 46. RTC2 register map

The RTC2 timer is a 16 bit timer counting from zero and upwards at the rate of the 32.768 kHz clock. When the RTC2 timer is equal to the concatenation of RTC2CMP1 and RTC2CMP0, an RTC2 IRQ, also referred to as TICK, is generated. There is an uncertainty of one CLKLF period, 30.52 μ s, from when the RTC2 is started or a new value is given to the RTC2 compare value registers and until the IRQ is given.

The time for the IRQ is given by the range:

$$\left[\frac{[\text{RTC2CMP1} : \text{RTC2CMP0}] - \text{timer}}{32768}, \frac{[\text{RTC2CMP1} : \text{RTC2CMP0}] - \text{timer} + 1}{32768} \right] [\text{s}]$$

where $[\text{RTC2CMP1} : \text{RTC2CMP0}]$ is the concatenation of RTC2CMP1 and RTC2CMP0 into a 16 bits word and **timer** is the current value of the RTC2 timer when the RTC2 compare value register was updated or the RTC2 enabled.

If compare mode 11 is used, the RTC2 IRQ will be given every

$$\frac{[\text{RTC2CMP1} : \text{RTC2CMP0}] + 1}{32768} [\text{s}]$$

second.

The RTC2 compare value is updated every time RTC2CMP1 or RTC2CMP0 is written. This might give unwanted behavior if precaution is not taken when updating any of the variables. When new values are written to RTC2CMP1 and RTC2CMP0 , the RTC2 IRQ should be disabled to prevent unwanted RTC2 IRQ.

To make sure everything is up and running when the RTC2 IRQ is given in Register retention or Memory retention timers on, the MCU is pre-started before the IRQ is given. If XOSC16M is enabled, the pre-start time is long enough to make sure that this clock is up and running before the IRQ is given.¹ If RCOSC16M is enabled by $\text{CLKCTRL}[5:4]$, this will be the clock source in the pre-start period. To save power, the user could choose to go to Standby while waiting for the IRQ. If only RCOSC16M is enabled, the pre-start time is shorter, making sure that the RC-oscillator is up and running before the RTC2 IRQ is given. This same, short pre-startup time is used from Register Retention to Active if XOSC16M is running while in Register retention² $\text{CLKCTRL}[7] = 1$.

This implies that the time from going to Register retention or Memory retention and until the RTC2 IRQ is given, always must be longer then the pre-start time: 49 CLKLF periods for the long pre-start and 2 CLKLF for the short pre-start.

The RTC2 counter uses the 32.768 kHz low frequency clock for the RTC2 timer, and one of the 32.768 kHz sources must be enabled when using the RTC2. See [section 13.3 on page 121](#) for the 32.768 kHz clock.

Reading RTC2CMP0 and RTC2CMP1:

- Disable the RTC2 IRQ, until both registers have been written.

1. The crystal start-up time must be <1.5 ms to ensure that XOSC16M is clock source on arrival of the RTC2 IRQ. Refer to [section 13.3.1 on page 121](#) for further details.

2. To get the short pre-startup time when going to Register retention with XOSC16M running in the power down mode, make sure XOSC16M is running before going to Register retention. If it is not, the long pre-start time is used, and the minimum value for the long pre-startup for the RTC2 compare value register should be used. This applies only the first time going to Register retention after enabling XOSC16M in Register retention.

Reading RTC2CPT00, RTC2CPT01 and RTC2CPT10:

- Disable The Radio IRQ until all three registers have been read.

Uncertainty in capture values:

- 250 ns.

9 Interrupts

nRF24LE1 has an advanced interrupt controller with 18 sources, as shown in [Figure 46](#). The unit manages dynamic program sequencing based upon important real-time events as signalled from timers, the RF Transceiver, pin activity, and so on.

9.1 Features

- Interrupt controller with 18 sources and 4 priority levels
- Interrupt request flags available
- Interrupt from pin (configurable)

9.2 Block diagram

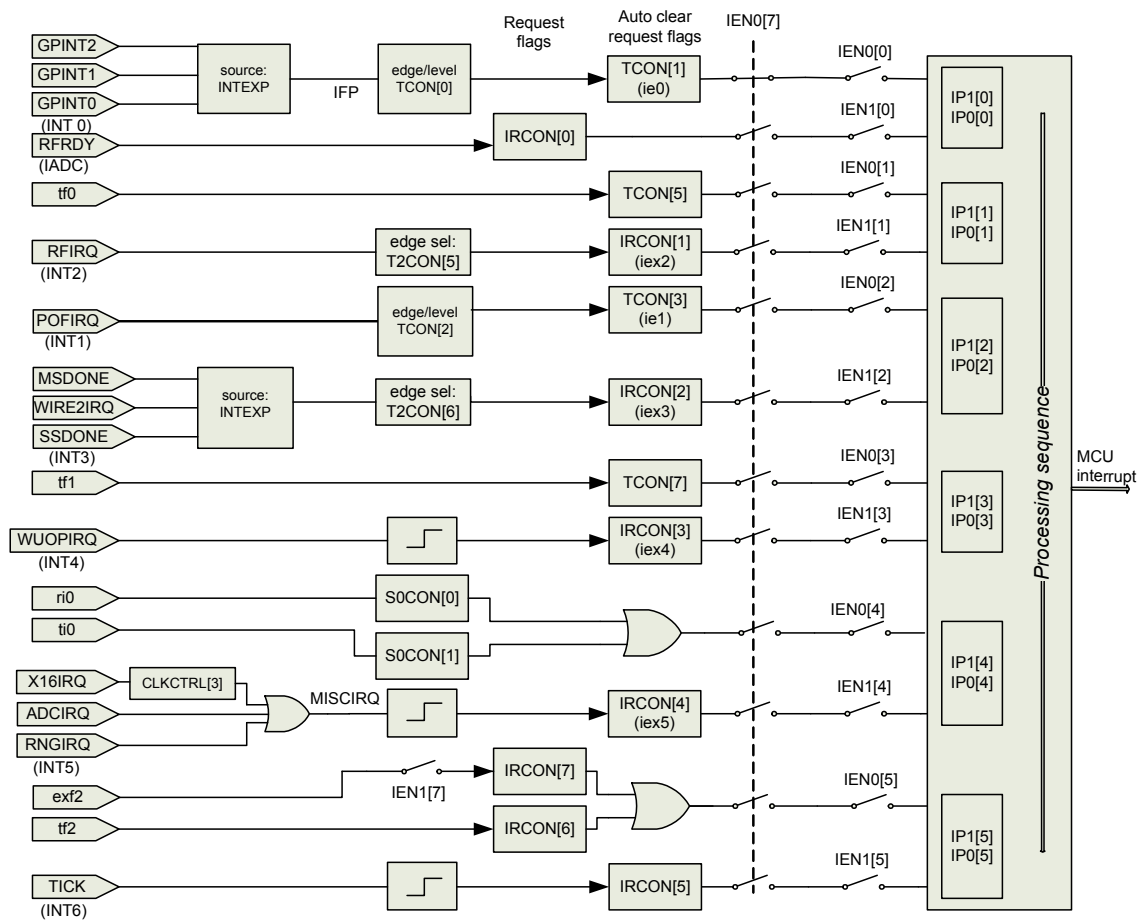

Figure 46. Block diagram of interrupt structure

9.3 Functional description

When an enabled interrupt occurs, the MCU vectors to the address of the interrupt service routine (ISR) associated with that interrupt, as listed in [Table 47](#). The MCU executes the ISR to completion unless another interrupt of higher priority occurs.

Source	vector	Polarity	Description
IFP	0x0003	low/fall	Interrupt from pin GP INT0, GP INT1 or GP INT2 as selected by bits 3,4 or 5 in SFR INTEXP. Only one of the bits may be set at a time.
tf0	0x000B	high	Timer 0 overflow interrupt
POFIRQ	0x0013	low/fall	Power Failure interrupt
tf1	0x001B	high	Timer 1 overflow interrupt
ri0	0x0023	high	Serial channel receive interrupt
ti0	0x0023	high	Serial channel transmit interrupt
tf2	0x002B	high	Timer 2 overflow interrupt
exf2	0x002B	High	Timer 2 external reload
RFRDY	0x0043	high	RF SPI ready
RFIRQ	0x004B	fall/rise	RF interrupt
MSDONE	0x0053	fall/rise	Master SPI transaction completed
WIRE2IRQ	0x0053	fall/rise	2-Wire transaction completed
SSDONE	0x0053	fall/rise	Slave SPI transaction completed
WUOPIRQ	0x005B	rise ^a	Wakeup on pin interrupt
MISCIRQ	0x0063	rise	Miscellaneous interrupt is the sum of: <ul style="list-style-type: none"> XOSC16M started (X16IRQ) ADC Ready (ADCIRQ) interrupt RNG ready (RNGIRQ) interrupt
TICK	0x006B	rise	Internal Wakeup (from RTC2) interrupt

a. Polarity is always rise on interrupt, but pin polarity can be selected by bit 2 in the OPMCON register as described in [Table 61. on page 114](#).

Table 47. nRF24LE1 interrupt sources

Note: RFIRQ, WUOPIRQ, MISCIRQ and TICK are not activated unless wakeup is enabled by WUCON (see [section 11.3.5 on page 115](#)).

9.4 SFR registers

Various SFR registers are used to control and prioritize between different interrupts.

The TCON, IRCON, SCON, IP0, IP1, IEN0, IEN1 and INTEXP are described in this section. In addition the TCON and T2CON are used, the description for these registers can be found in [chapter 8 on page 86](#).

9.4.1 Interrupt Enable 0 Register – IEN0

The IEN0 register is responsible for global interrupt system enabling/disabling and also Timer 0, 1 and 2, Port 0 and Serial Port individual interrupts enabling/disabling.

Address	Bit	Description
0xA8	7	1: Enable interrupts. 0: all interrupts are disabled
	6	Not used
	5	1: Enable Timer2 (tf2/exf2) interrupt.
	4	1: Enable Serial Port (ri0/ti0) interrupt.
	3	1: Enable Timer1 overflow (tf1) interrupt
	2	1: Enable Power failure (POFIRQ) interrupt
	1	1: Enable Timer0 overflow (tf0) interrupt.
	0	1: Enable Interrupt From Pin (IFP) interrupt.

Table 48. IEN0 register

9.4.2 Interrupt Enable 1 Register – IEN1

The IEN1 register is responsible for RF, SPI and Timer 2 interrupts.

Address	Bit	Description
0xB8	7	1: Enable Timer2 external reload (exf2) interrupt
	6	Not used
	5	1: Internal wakeup (TICK) interrupt enable
	4	1: Miscellaneous (MISCIRQ) interrupt enable
	3	1: Wakeup on pin (WUOPIRQ) interrupt enable
	2	1: 2-Wire completed (WIRE2IRQ) interrupt, SPI master/slave completed (MSDONE/SSDONE) interrupt enable
	1	1: RF (RFIRQ) interrupt enable
	0	1: RF SPI ready (RFRDY) interrupt enable

Table 49. IEN1 register

2-Wire Master SPI and Slave SPI share the same interrupt line.

Address	Bit	Description	Reset value 0x01
0xA6	7:6	not used	
	5	1: Enable GP INT2 (from pin) to IFP	
	4	1: Enable GP INT1 (from pin)1 to IFP	
	3	1: Enable GP INT0 (from pin) 0 to IFP	
	2	1: Enable 2-Wire completed (WIRE2IRQ) interrupt	
	1	1: Enable Master SPI completed (MSDONE)interrupt	
	0	1: Enable Slave SPI completed (SSDONE) interrupt	

Table 50. INTEXP register

9.4.3 Interrupt Priority Registers – IP0, IP1

The 14 interrupt sources are grouped into six priority groups. For each of the groups, one of four priority levels can be selected. They can be selected by setting appropriate values in IP0 and IP1 registers.

The contents of the Interrupt Priority registers define the priority levels for each interrupt source according to the tables below.

Address	Bit	Description
0xA9	7:6	Not used
	5:0	Interrupt priority. Each bit together with corresponding bit from IP1 register specifies the priority level of the respective interrupt priority group.

Table 51. IP0 register

Address	Bit	Description
0xB9	7:6	Not used
	5:0	Interrupt priority. Each bit together with corresponding bit from IP0 register specifies the priority level of the respective interrupt priority group.

Table 52. IP1 register

Group	Interrupt bits	Priority groups		
0	IP1[0], IP0[0]	IFP	RFRDY	
1	IP1[1], IP0[1]	tf0	RFIRQ	
2	IP1[2], IP0[2]	POFIRQ	MSDONE	SSDONE
3	IP1[3], IP0[3]	tf1	WUOPIRQ	
4	IP1[4], IP0[4]	ri0	ti0	MISCIRQ
5	IP1[5], IP0[5]	tf2/exf2	TICK	

Table 53. Priority groups

IP1[x]	IP0[x]	Priority level
0	0	Level 0 (lowest)
0	1	Level 1
1	0	Level 2
1	1	Level 3 (highest)

Table 54. Priority levels (x is the number of priority group)

9.4.4 Interrupt Request Control Registers – IRCON

The IRCON register contains interrupt request flags.

Address	Bit	Auto clear	Description
0xC0	7	No	Timer 2 external reload (exf2) interrupt flag
	6	No	Timer 2 overflow (tf2) interrupt flag
	5	Yes	Internal wakeup (TICK) interrupt flag
	4	Yes	Miscellaneous (MISCIRQ) interrupt flag
	3	Yes	Wakeup on pin (WUOPIRQ) interrupt flag
	2	Yes	2-Wire completed (WIRE2IRQ), Master/Slave SPI (MSDONE/SSDONE) interrupt flag
	1	Yes	RF (RFIRQ) interrupt flag
	0	No	RF SPI ready (RFRDY) interrupt flag

Table 55. IRCON register

10 Watchdog

The on-chip watchdog forces a system reset if the running software for some reason encounters a hang situation.

10.1 Features

- 32.768 kHz, sub- μ A.
- 16-bit with an offset of 8 bits.
- Minimum Watchdog timeout interval: 7.8125 ms.
- Maximum Watchdog timeout interval: 512 s.
- Disable (reset) only by a system reset, or possibly when the chip enters the following power saving modes: Register retention and Memory retention. See [section 17.3.2 on page 137](#) for details.

10.2 Block diagram

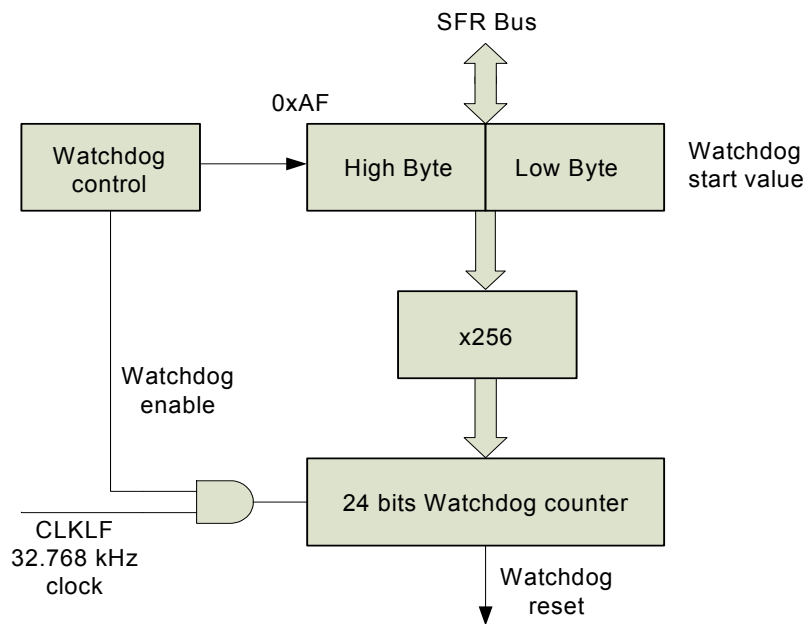

Figure 47. Watchdog block diagram

10.3 Functional description

The following register controls the Watchdog.

Address (Hex)	Name/Mnemonic	Bit	Reset value	Type	Description
0xAF	WDSV	15:0	0x0000	R/W	Watchdog start value register. MSByte and LSByte of the word are written and read as separate bytes.

Table 56. Watchdog register

watchdogStartValue (WDSV) contains the upper 16 bits of the Watchdog counters initial value. This 16 bits word is read and written as two separate bytes, LSByte and MSByte. LSByte is read and written first. After a write to WDSV, the next read of WDSV will always give the LSByte, and after a read, the next byte written will always be to the LSByte. In other words, to write to WDSV, two bytes must be written without a read between the writes, and vice-versa for read operations. Readout of WDSV will not give the current value of the Watchdog counter, but the start value for the counter.

After a reset, the default state of the Watchdog is disabled. The Watchdog is activated when both bytes of WDSV have been written. The Watchdog counter then counts down from WDSV*256 towards 0. When 0 is reached, the complete microcontroller, as well as the peripherals, are reset. A reset from the Watchdog will have the same effect as a power-on reset or a reset from pin. To avoid the reset, the software must reload WDSV sufficiently often. The Watchdog counter is updated with a new start value and restarted every time WDSV is written.

The Watchdog counter uses the 32.768 kHz low frequency clock, and one of the 32.768 kHz sources must be enabled when using the Watchdog. See [section 13.3 on page 121](#) for the 32.768 kHz clock.

The Watchdog timeout is given by:

$$\frac{\text{WDSV} * 256}{32768} [s]$$

If WDSV is loaded with 0x0000, the maximum Watchdog timeout interval of 512 seconds is used, i.e. the Watchdog is not disabled.

If the Watchdog has been started, it can only be disabled (reset) by a system reset, or possibly when the chip enters the Register retention or Memory retention power-saving mode. Please refer to OPMCON bit 0 in [Table 61. on page 114](#).

11 Power and clock management

The nRF24LE1 Power Management function controls the power dissipation through administration of modes of operation and by controlling clock frequencies.

11.1 Block diagram

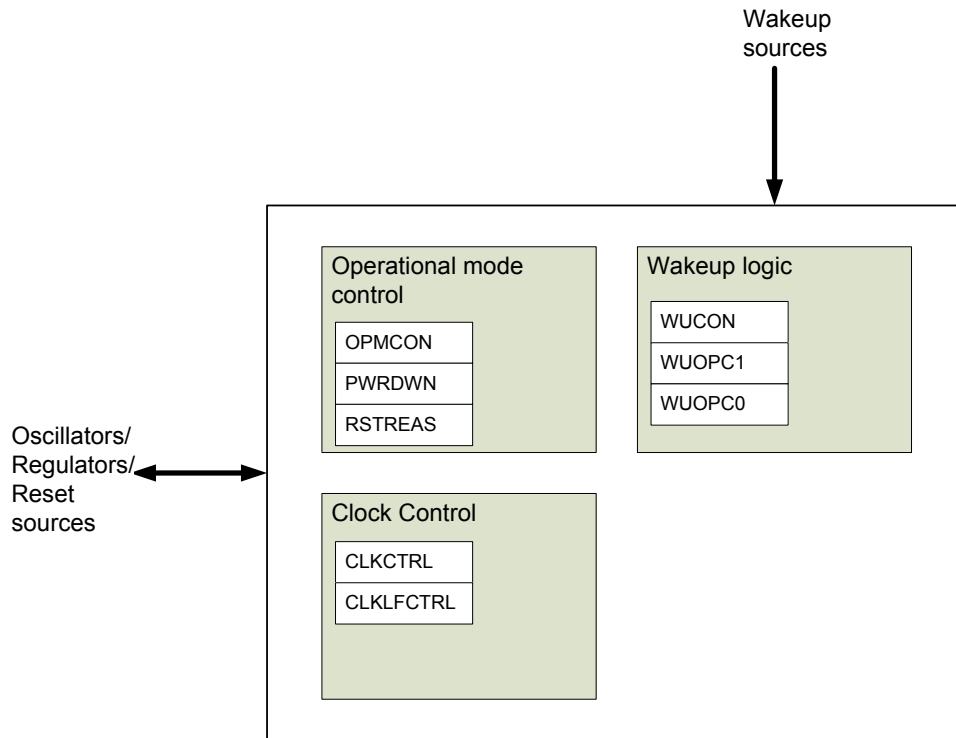

Figure 48. Block diagram of power and clock management

11.2 Modes of operation

After nRF24LE1 is reset or powered on it enters active mode and the functional behavior is controlled by software. To enter one of the power saving modes, the PWRDWN register must be written with selected mode (as data).

To re-enter the active mode a wakeup source (valid for given power down mode) has to be activated.

The nRF24LE1 modes of operation are summarized in the following table:

Mode	Brief description
Deep Sleep ^a	<p>Current: See Table 115. on page 184</p> <p>Powered functions:</p> <ul style="list-style-type: none"> • pins inclusive wakeup filter <p>Wakeup source(s): From pin</p> <p>Start-up time:</p> <ul style="list-style-type: none"> • < 100 us when starting on RCOSC16M <p>Comment: Wakeup from pin will in this mode lead to a system reset (after wakeup, program execution will start from the reset vector).</p>
Memory retention, timers off	<p>Current: See Table 115. on page 184</p> <p>Powered functions: In addition to Deep Sleep:</p> <ul style="list-style-type: none"> • Power Manager • IRAM and 512 bytes of data memory (DataRetentive SRAM) <p>Wakeup source(s): From pin</p> <p>Start-up time: As for Deep Sleep</p> <p>Comment: Wakeup from pin will in this mode lead to a system reset.</p>

Mode	Brief description
Memory retention, timers on	<p>Current: See Table 115. on page 184</p> <p>Powered functions: In addition to Memory retention, timers off:</p> <ul style="list-style-type: none"> • XOSC32K or RCOSC32K • RTC2 and watchdog clocked on 32 kHz clock <p>Wakeup source(s): From pin, wakeup TICK from timer or voltage level on pin (analog comparator wakeup)</p> <p>Start-up time: Wakeup from pin:</p> <ul style="list-style-type: none"> • < 100 us when starting on RCOSC16M <p>Wakeup TICK:</p> <ul style="list-style-type: none"> • Pre-start voltage regulators and XOSC16M, system ready on RTC2 TICK. To save power, the user may choose to enter Standby power-down mode when the MCU system is awoken (<100µs) and wait for TICK interrupt. A short pre-start time (a few clock cycles) is used when XOSC16M is not enabled as controlled by CLKCTRL bit 5 and 4 (please refer to Table 59. on page 112. <p>Comment: Wakeup will lead to system reset</p>
Register retention, timers off ^b	<p>Current: See Table 115. on page 184</p> <p>Powered functions: In addition to Memory retention, timers on:</p> <ul style="list-style-type: none"> • All registers • Rest of data memory (SRAM) • Optional: XOSC16M <p>Wakeup source(s): As for Memory retention, timers off. See also footnote for bit 7 regarding wakeup in Table 58. on page 111 .</p> <p>Start-up time: As for memory retention, timers on.</p> <p>Comment: Wakeup does not lead to system reset (after wakeup, program execution will resume from the current instruction).</p>

Mode	Brief description
Register retention, timers on ^a	<p>Current: See Table 115. on page 184</p> <p>Powered functions: As for Register retention, timers off.</p> <p>Wakeup source(s): As for Memory retention, timers on. See also footnote for bit 7 regarding wakeup in Table 58. on page 111 .</p> <p>Start-up time: As for Register retention, timers off. If awoken from TICK, a short pre-start time is used when XOSC16M is not enabled as controlled by CLKCTRL bit 5 and 4 (refer to Table 59. on page 112) or when XOSC16M is on in the Register retention mode (CLKCTRL bit 7). The short pre-start time will not be used if entering power-down before XOSC16M is running (this can be observed by polling bit 3 in CLKLFCTRL).</p> <p>Comment: Wakeup does not lead to system reset (after wakeup, program execution will resume from the current instruction).</p>
Standby	<p>Current: See Table 115. on page 184</p> <p>Powered functions: In addition to Register retention:</p> <ul style="list-style-type: none"> • Program memory and Data memory • VREG • XOSC16M <p>Wakeup source(s): In addition to Register retention:</p> <ul style="list-style-type: none"> • The interrupt sources RFIRQ and MISCIRQ (see section 9.3 on page 100 and 11.3.5 on page 115. Analog wakeup comparator is not supported in this mode. <p>Start-up time: ~ 100 ns</p> <p>Comment: Processor in standby, that is, clock stopped. IO functions may be active.</p>

Mode	Brief description
Active	Current: See Table 115. on page 184 Powered functions: Everything powered Wakeup source(s): - Start-up time: - Comment: Processor active and running

- a. The 16 MHz RC oscillator must be turned on before nRF24LE1 enters Deep Sleep.
- b. Please note that both Register retention power-down modes are entered by writing '100' to the PWRDWN register (refer to [Note: on page 113](#)). "Register retention timers on" is obtained by choosing an active CLKLF source as controlled by CLKLFCTRL [2:0] (refer to [Table 59. on page 112](#)).

Table 57. Modes of operation

11.3 Functional description

11.3.1 Clock control

The clock to the MCU (Cclk) is sourced from either an on-chip RC oscillator or a crystal oscillator (see [chapter 13 on page 120](#)) for details.

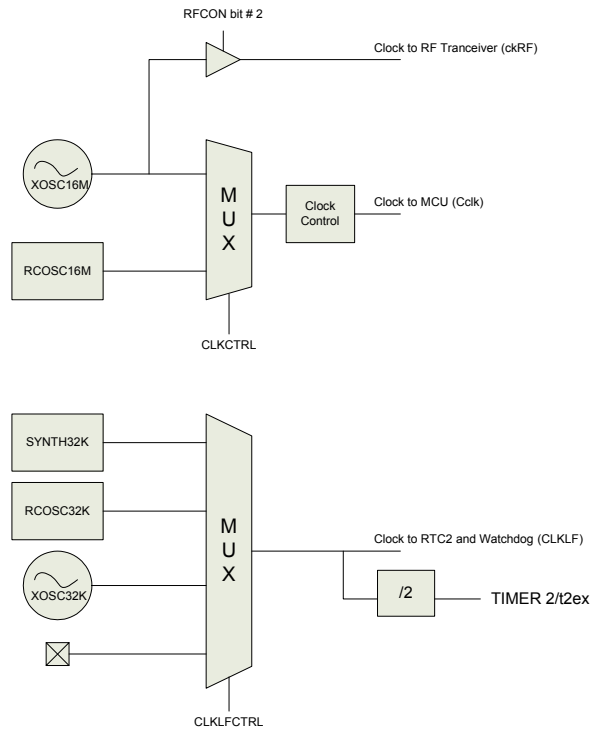

Figure 49. nRF24LE1 clock system

The source and frequency of the clock to the microcontroller system is controlled by the `CLKCTRL` register.

Addr	Bit	R/W	Function	Reset value: 0x00
0xA3	7 ^a	R/W	1: Keep XOSC16M on in Register retention mode	
	6	R/W	1: Clock sourced directly from pin (XC1), bypass oscillators ^b . 0: Clock sourced by XOSC16M or RCOSC16M, see bit 3	
	5:4 ^c	R/W	00: Start both XOSC16M and RCOSC16M. ^d 01: Start RCOSC16M only. 10: Start XOSC16M only. ^e 11: Reserved	
	3	R/W	1: Enable wakeup and interrupt (X16IRQ) from XOSC16M active 0: Disable wakeup and interrupt from XOSC16M active	
	2:0	R/W	Clock frequency to microcontroller system: 000: 16 MHz 001: 8 MHz 010: 4 MHz 011: 2 MHz 100: 1 MHz 101: 500 kHz 110: 250 kHz 111: 125 kHz	

- a. If this bit is set to '1', it is necessary to write '00' to bit 5:4 before entering Register retention mode. Otherwise, wakeup may not function properly.
- b. For test and application development involving no radio link, only. Must be cleared in normal operation.
- c. When writing to this bit, the device must be put in Register retention, Memory retention or Deep Sleep for effects to occur.
- d. Default setting, both oscillators started. Clock sourced from RCOSC16M initially and automatically switched to XOSC16M
- e. The 16 MHz RC oscillator must be turned on before nRF24LE1 enters Deep Sleep.

Table 58. `CLKCTRL` register

. The source of the 32 kHz clock (CLKLF) is controlled by the CLKLFCTRL register:

Addr	Bit	R/W	Function	Reset value: 0x07
0xAD	7	R	1: Read CLKLF (phase).	
	6	R	1: CLKLF ready to be used	
	5	-	Reserved	
	4	-	Reserved	
	3	R	1: Clock sourced by XOSC16M (that is, XOSC16M active/running) 0: Clock sourced by RCOSC16M	
	2:0	R/W	Source for CLKLF: 000: XOSC32K 001: RCOSC32K 010: Synthesized from XOSC16M when active, off otherwise ^a 011: From IO pin used as XC1 to XOSC32K (low amplitude signal) 100: From IO pin (digital rail-to-rail signal) 101: Reserved 110: Reserved 111: None selected	

- a. XOSC16M will be stopped in Deep Sleep and Memory Retention, and therefore, stopping CLKLF in these modes of operation.

Table 59. CLKLFCTRL register

Note: If a source for CLKLF is selected, the MCU system will not start unless CLKLF is operative. For example, when selecting CLKLF from IO pin the external clock must be active for the MCU to wake up by pin from memory retention.

11.3.2 Power down control – PWRDWN

The PWRDWN register is used by the MCU to set the system to a power saving mode:

Addr	Bit	R/W	Function	Reset value: 0x00
0xA4	7	R	Indicates a wakeup from pin if set This bit is either cleared by a read or by entering a power down mode	
	6	R	Indicates a wakeup from TICK if set This bit is either cleared by a read or by entering a power down mode	
	5	R	Indicates a wakeup from Comparator if set This bit is either cleared by a read or by entering a power down mode	
	4:3		Reserved	
	2:0	W R	Set system to power down if different from 000 001: set system to DeepSleep 010: set system to Memory retention, timer off 011: set system to Memory retention, timer on 100: set system to Register retention 101: reserved 110: reserved 111: set system to standby (stop MCU clock) Shows previous power down mode 000: Power off 001: DeepSleep 010: Memory retention, timer off 011: Memory retention, timer on 100: Register retention 101: reserved 110: reserved 111: standby	

Note: On wakeup from powerdown the PWRDWN register should be reset to 0x00. The content of the register can be read out first if needed.

Table 60. PWRDWN register

11.3.3 Operational mode control - OPMCON

The OPMCON register is used to control special behavior in some of the operation modes:

Addr	Bit	R/W	Function	Reset value: 0x00
0xAE	7:3	-	Reserved (always write '0' to these bits)	
	2	R/W	1: Subset of wakeup pins have active low polarity 0: All wakeup pins have active high polarity. Refer to section 11.3.6 on page 115 .	
	1	R/W	Retention latch control 0: Latch open – pass through 1: Latch locked To keep some internal chip setup, such as pin directions/setup, you need to lock a set of retention latches before entering DeepSleep and memory retention power saving modes. After a wake up you must re-establish the register settings before opening the retention latches.	
	0	R/W	Watchdog reset enable 0: If the on-chip watchdog functionality is enabled it will keep running as long the operational mode Deep Sleep is not entered. 1: The on-chip watchdog functionality will enter its reset state when the operational mode Memory Retention and Register Retention is entered.	

Table 61. OPMCON register

Note: If the Watchdog reset enable bit is enabled, you must wait at least until the first negative edge of CLKLF after enabling CLKLF, before proceeding to Register Retention or Memory Retention. Waiting for the negative edge of CLKLF is not needed when entering into any other power-down state or if the Watchdog reset enable is not enabled.

11.3.4 Reset result – RSTREAS

There are four reset sources that initiate the same reset/ start-up sequence. These are:

- Reset from the on chip reset generator
- Reset from pin
- Reset generated from the on chip watchdog function
- Reset from on-chip hardware debugger

The RSTREAS register stores the reason for the last reset, all cleared indicates that the last reset was from the on-chip reset generator. A write operation to the register will clear all bits. Unless cleared after read (by on-chip reset or by a write operation), RSTREAS will be cumulative. That is, a reset from the debugger followed by a watchdog reset will set RSTREAS to 110.

Addr	Bit	R/W	Function
0xB1	7:3	-	Not used
	2:0	R	000: On-chip reset generator 001: RST pin 010: Watchdog 100: Reset from on-chip hardware debugger

Table 62. RSTREAS register

11.3.5 Wakeup configuration register – WUCON

The following wakeup sources is available in STANDBY power down mode.

Addr	Bit	R/W	Function	Reset value 0x00
0xA5	7:6	RW	00: Enable wakeup on RFIRQ if interrupt is enabled (IEN1.1=1) 01: Reserved, not used 10: Enable wakeup on RFIRQ 11: Ignore RFIRQ	
	5:4	RW	00: Enable wakeup on TICK (from RTC2) if interrupt is enabled (IEN1.5=1) 01: Reserved, not used 10: Enable wakeup on TICK 11: Ignore TICK	
	3:2	RW	00: Enable wakeup on WUOPIRQ if interrupt is enabled (IEN1.3=1) 01: Reserved, not used 10: Enable wakeup on WUOPIRQ 11: Ignore WUOPIRQ	
	1:0	RW	00: Enable wakeup on MISCIRQ if interrupt is enabled (IEN1.4=1) 01: Reserved, not used 10: Enable wakeup on MISCIRQ 11: Ignore MISCIRQ	

Table 63. WUCON register

MISCIRQ is set if one of the following take place:

- XOSC16M has started and is ready to be used.
- ADC finished with conversion, and data ready.
- RNG finished and a new random number is ready

11.3.6 Pin wakeup configuration

Pin wakeup is configured by two registers, WUOPC1 and WUOPC2

Address (Hex)	Name/Mnemonic	Bit	Reset value	Type	Description
0xCE	WUOPC1	7:0	0x00	R/W	Wake Up On Pin configuration register 1. n = 1: Wake up on pin enabled. n = 0: Wake up on the corresponding pin disabled.
0xCF	WUOPC0	7:0	0x00	R/W	Wake Up On Pin configuration register 0. n = 1: Wake up on pin enabled. n = 0: Wake up on the corresponding pin disabled.

Table 64. WUOPCx registers

The function for the WUOPCx registers depends on selected package. The following table shows which port-pin/ gpio that give wakeup if the corresponding enable bit in the WUOPCx register is asserted for each

nRF24LE1 package variant. Pins marked with an asterisk have selectable polarity controlled by OPM-CON.2. All other pins have high polarity.

WUOPC bit	nRF24LE1-Q48 wakeup pins	nRF24LE1-32 wakeup pins	nRF24LE1-Q24 wakeup pins
WUOPC1(7)	P1.7	Not used	Not used
WUOPC1(6)	P3.6	P1.6	Not used
WUOPC1(5)	P3.5	P1.5	Not used
WUOPC1(4)	P3.4	P1.4*	Not used
WUOPC1(3)	P3.3	P1.3	Not used
WUOPC1(2)	P3.2	P1.2*	Not used
WUOPC1(1)	P3.1	P1.1	Not used
WUOPC1(0)	P3.0	P1.0	Not used
WUOPC0(7)	P2.7	P0.7	Not used
WUOPC0(6)	P2.6*	P0.6*	P0.6*
WUOPC0(5)	P2.5	P0.5	P0.5
WUOPC0(4)	P2.4	P0.4	P0.4
WUOPC0(3)	P2.3	P0.3	P0.3
WUOPC0(2)	P2.2*	P0.2	P0.2
WUOPC0(1)	P2.1	P0.1	P0.1
WUOPC0(0)	P2.0	P0.0	P0.0

Table 65. Configuration of pin wakeup

If the SPI Slave function is enabled, that is, bit 0 in the SPISCON0 register is set, the spiSlaveCsn signal becomes an active low pin wakeup source.

12 Power supply supervisor

The power supply supervisor initializes the system at power-on, provides an early warning of impending power failure, and puts the system in reset state if the supply voltage is too low for safe operation.

12.1 Features

- Power-on reset with timeout delay
- Brown-out reset operational in all system modes
- Power-fail warning with programmable threshold, interrupt and hardware protection of data in program memory

12.2 Block diagram

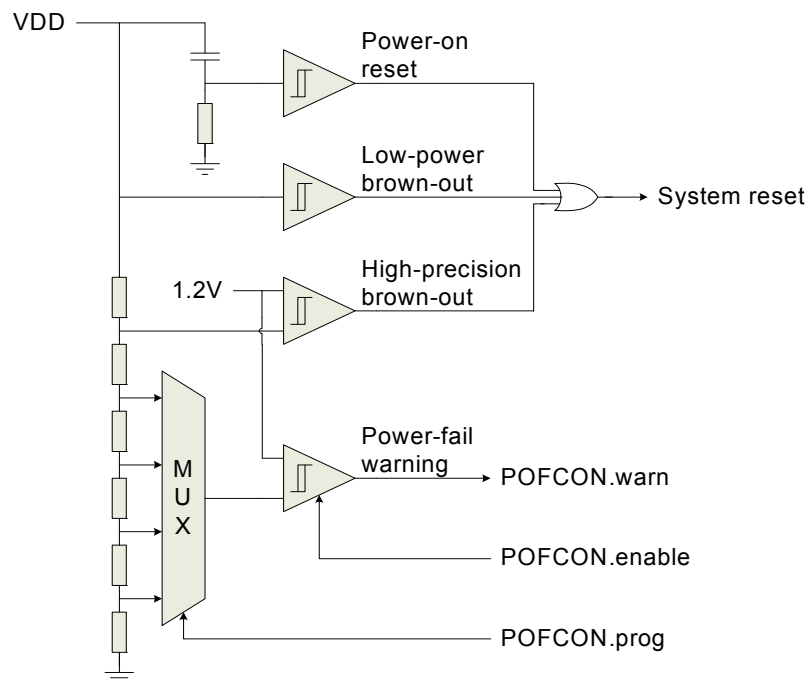

Figure 50. Block diagram of power supply supervisor

12.3 Functional description

12.3.1 Power-on reset

The Power-On Reset (POR) generator initializes the system at power-on. It is based on an RC network and a comparator, as illustrated in [Figure 50](#). For proper operation the supply voltage should rise monotonically with rise time according to the specifications in [Table 112. on page 177](#). The system is held in reset state for at least 1ms after the supply has reached the minimum operating voltage of 1.9V.

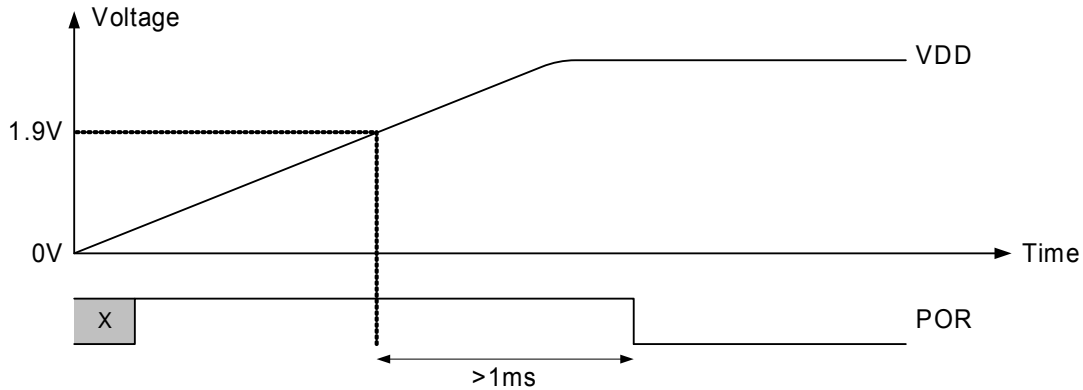

Figure 51. Power-on reset

12.3.2 Brown-out reset

The Brown-Out Reset (BOR) generator puts the system in reset state if the supply voltage drops below the BOR threshold. It consists of a high precision comparator that is enabled when the system is in active and standby mode, and a less accurate low power comparator that is operational in all other modes. The former has a threshold voltage of about 1.7V. There are approximately 70mV of hysteresis (V_{HYST}). This means that if a reset is triggered when the supply voltage drops below 1.7V, the supply must rise above 1.77V again before the nRF24LE1 becomes operational. Hysteresis prevents the comparator output from oscillating when VDD is close to threshold. The low-power comparator has a typical threshold voltage of 1.5V.

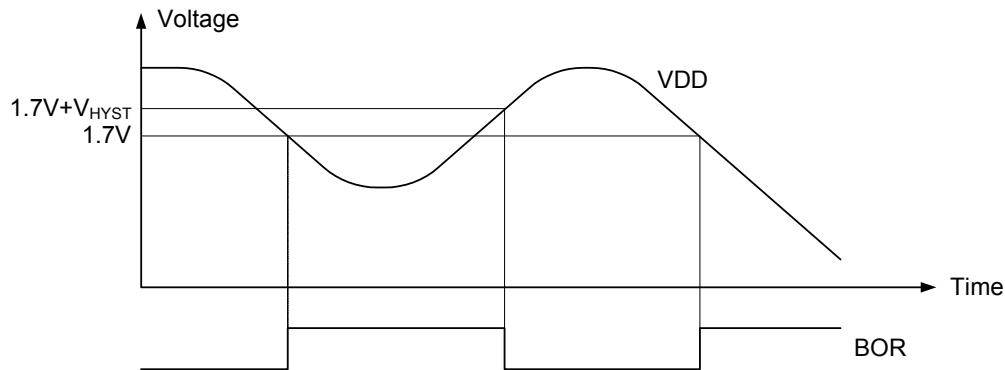

Figure 52. Brown-out reset

12.3.3 Power-fail comparator

The Power-Fail (POF) comparator provides the MCU with an early warning of impending power failure. It will not reset the system, but gives the MCU time to prepare for an orderly power-down. It also provides hardware protection of data stored in program memory, by preventing write instructions from being executed. Refer to [section 6.3.3 on page 76](#) for details.

The POF comparator is enabled or disabled by writing the **enable** bit in the POFCON register (see [Table 66. on page 119](#)). When enabled, it will be powered up when the system is in active or standby mode. The **warn** bit is set to '1' if the supply voltage is below the programmable threshold. An interrupt (POFIRQ) is also produced. Write instructions to program memory will not be executed as long as **warn** is '1'.

Use the **prog** bits to configure the desired threshold voltage (V_{POF}). The available levels are 2.1, 2.3, 2.5 and 2.7V, defined for falling supply voltage. The comparator has approximately 0.1V of hysteresis (V_{HYST}).

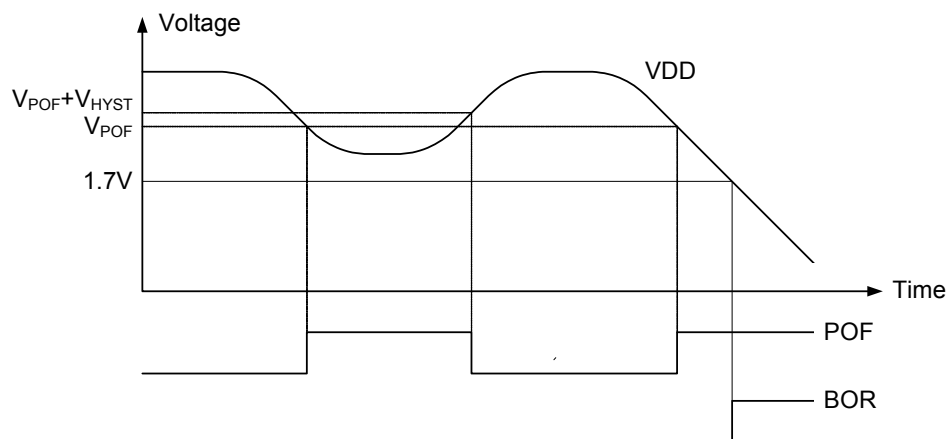

Figure 53. Power-fail comparator

12.4 SFR registers

Addr	Bit	Name	RW	Function	Reset value: 0x00
0xDC	7	enable	RW	POF enable: 0: Disable POF comparator 1: Enable POF comparator	
	6:5	prog	RW	POF threshold: 00: 2.1V 01: 2.3V 10: 2.5V 11: 2.7V	
	4	warn	R	POF warning: 0: VDD above threshold 1: VDD below threshold	
	3:0	-	-	Not used	

Table 66. POFCON register

13 On-chip oscillators

The nRF24LE1 contains two high frequency oscillators and two low frequency oscillators. The primary high frequency clock source is a 16 MHz crystal oscillator. There is also a fast starting 16 MHz RC oscillator, which is used primarily to provide the system with a high frequency clock while it is waiting for the crystal oscillator to start up. The low frequency clock can be supplied by either a 32.768 kHz crystal oscillator or a 32.768 kHz RC oscillator. External 16 MHz and 32.768 kHz clocks may also be used instead of the on-chip oscillators. See section [11.3.1 on page 110](#) for control of the clock sources.

13.1 Features

- Low-power amplitude regulated 16 MHz crystal oscillator
- Fast starting 16 MHz RC oscillator with $\pm 5\%$ frequency accuracy
- Ultra low-power amplitude regulated 32.768 kHz crystal oscillator
- Ultra low-power 32.768 kHz RC oscillator with $\pm 10\%$ frequency accuracy

13.2 Block diagrams

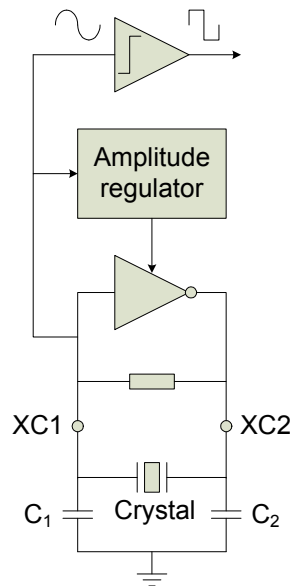

Figure 54. Block diagram of 16 MHz crystal oscillator

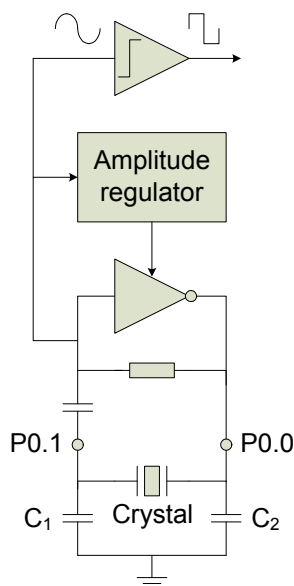

Figure 55. Block diagram of 32.768 kHz crystal oscillator

13.3 Functional description

13.3.1 16 MHz crystal oscillator

The 16 MHz crystal oscillator (XOSC16M) is designed to be used with an AT-cut quartz crystal in parallel resonant mode. To achieve correct oscillation frequency it is very important that the load capacitance matches the specification in the crystal datasheet. The load capacitance is the total capacitance seen by the crystal across its terminals:

$$C_{LOAD} = \frac{C_1' \cdot C_2'}{C_1' + C_2'}$$

$$C_1' = C_1 + C_{PCB1} + C_{PIN}$$

$$C_2' = C_2 + C_{PCB2} + C_{PIN}$$

C1 and C2 are ceramic SMD capacitors connected between each crystal terminal and VSS, CPCB1 and CPCB2 are stray capacitances on the PCB, while CPIN is the input capacitance on the xc1 and xc2 pins of the nRF24LE1 (typically 1pF). C1 and C2 should be of the same value, or as close as possible.

To ensure a functional radio link the frequency accuracy must be ± 60 ppm or better. The initial tolerance of the crystal, drift over temperature, aging and frequency pulling due to incorrect load capacitance must all be taken into account. For reliable operation the crystal load capacitance, shunt capacitance, equivalent series resistance (ESR) and drive level must comply with the specifications in [Table 114. on page 182](#). It is recommended to use a crystal with lower than maximum ESR if the load capacitance and/or shunt capacitance is high. This will give faster start-up and lower current consumption.

The start-up time is typically about 1 ms for a crystal with 9 pF load capacitance and an ESR specification

of 60 Ω max. This value is valid for crystals in a 3.2×2.5 mm can. If you use the smallest crystal cans (like 2.0×2.5 mm), pay particular attention to the startup time of the crystal. These crystals have a longer startup than crystals in larger cans. To make sure the startup time is <1.5 ms use a crystal for load capacitance of 6pF. A low load capacitance will reduce both startup time and current consumption. For more details regarding how to measure the startup of a specific crystal, please see the nAN24-13 application note.

The crystal oscillator is normally running only when the system is in active or standby mode. It is possible to keep it on in register retention mode as well, by writing a '1' to bit 7 in the `CLKCTRL` register (see [Table 57. on page 105](#)). This is recommended if the system is expected to wake up again in less than 5 ms. The reason is that the additional current drawn during start-up makes it more power-efficient to let the oscillator run for a few extra milliseconds than to restart it.

13.3.2 16 MHz RC oscillator

The 16 MHz RC oscillator (`RCOSC16M`) is used primarily to provide a high speed clock while the crystal oscillator is starting up. It starts in just a few microseconds, and has a frequency accuracy of $\pm 5\%$.

By default, the 16 MHz RC and crystal oscillators are started simultaneously. The RC oscillator supplies the clock until the crystal oscillator has stabilized. The system then makes an automatic switch to the crystal oscillator clock, and turns off the RC oscillator to save power. Bit 3 in the `CLKCTRL` register can be polled to check which oscillator is currently supplying the high speed clock.

The system can be configured to start only one of the two 16 MHz oscillators. Write bit 4 and 5 in the `CLKCTRL` register to choose the desired behavior. Note that the RF Transceiver cannot be used while the high frequency clock is sourced by the RC oscillator. The ADC may also have reduced performance.

13.3.3 External 16 MHz clock

The nRF24LE1 may be used with an external 16 MHz clock applied to the `xc1` pin. Write a '1' to bit 6 in the `CLKCTRL` register if the external clock is a rail-to-rail digital signal (This is for test and application development involving no radio link, only. Bit 6 must be cleared in normal operation.) The input signal may also be analog, coming from e.g. the crystal oscillator of a microcontroller. In this case the crystal oscillator on the nRF24LE1 must also be enabled, since it is used to convert the analog input into a digital clock signal. `CLKCTRL[6]` must be '0', and `CLKCTRL[5:4]` must be '10' to enable the oscillator. An input amplitude of 0.8V peak-to-peak or higher is recommended to achieve low current consumption and a good signal-to-noise ratio. The DC level is not important as long as the applied signal never rises above `VDD` or drops below `VSS`. The `xc1` pin will load the microcontrollers crystal with approximately 1pF in addition to PCB routing. `xc2` shall not be connected.

Note: A frequency accuracy of ± 60 ppm or better is required to get a functional radio link.

13.3.4 32.768 kHz crystal oscillator

The 32.768 kHz crystal oscillator (`XOSC32K`) is operational in all system modes except deep sleep and memory retention, timer off. It is enabled by writing '000' to `CLKLFCCTRL[2:0]`.

A crystal must be connected between port pins `P0.0` and `P0.1`, which are automatically configured as crystal pins when the oscillator is enabled. To achieve correct oscillation frequency it is important that the load capacitance matches the specification in the crystal datasheet. The load capacitance is the total capacitance seen by the crystal across its terminals:

$$C_{LOAD} = \frac{C_1' \cdot C_2'}{C_1' + C_2'}$$

$$C_1' = C_1 + C_{PCB1} + C_{PIN}$$

$$C_2' = C_2 + C_{PCB2} + C_{PIN}$$

C_1 and C_2 are ceramic SMD capacitors connected between each crystal terminal and V_{SS} , C_{PCB1} and C_{PCB2} are stray capacitances on the PCB, while C_{PIN} is the input capacitance on the P0.0 and P0.1 pins of the nRF24LE1 (typically 3pF when configured as crystal pins). C_1 and C_2 should be of the same value, or as close as possible. The oscillator uses an amplitude regulated design similar to the 16 MHz crystal oscillator. For reliable operation the crystal load capacitance, shunt capacitance, equivalent series resistance (ESR) and drive level must comply with the specifications in [Table 114. on page 182](#). It is recommended to use a crystal with lower than maximum ESR if the load capacitance and/or shunt capacitance is high. This will give faster start-up and lower current consumption.

The start-up time is typically less than 0.5s for a crystal with 9pF load capacitance, 1pF shunt capacitance and an ESR of 50k Ω . Bit 6 in the `CLKLFCTRL` register can be polled to check if the oscillator is ready for use.

13.3.5 32.768 kHz RC oscillator

The low frequency clock may be generated by a 32.768 kHz RC oscillator (RCOSC32K) instead of the crystal oscillator, if a frequency accuracy of $\pm 10\%$ is sufficient. This saves the cost of a crystal, and also frees up P0.0 and P0.1 for other applications. The 32.768 kHz RC oscillator is enabled by writing '001' to `CLKLFCTRL[2:0]`. It typically starts in less than 0.5ms. Bit 6 in the `CLKLFCTRL` register can be polled to check if the oscillator is ready for use.

13.3.6 Synthesized 32.768 kHz clock

The low frequency clock can also be synthesized from the 16 MHz crystal oscillator clock. Write '010' to `CLKLFCTRL[2:0]` to select this option. The synthesized clock will only be available in system modes where the 16 MHz crystal oscillator is active. (This will be possible in the operational modes "Register retention," "Standby," and "Active.")

13.3.7 External 32.768 kHz clock

The nRF24LE1 may be used with an external 32.768 kHz clock applied to the P0.1 port pin. Write '100' to `CLKLFCTRL[2:0]` if the external clock is a rail-to-rail digital signal, or '011' if it is an analog signal coming from e.g. the crystal oscillator of a microcontroller. An analog input signal must have an amplitude of 0.2V peak-to-peak or higher. The DC level is not important as long as the applied signal never rises above V_{DD} or drops below V_{SS} . The P0.1 port pin will load the microcontrollers crystal with approximately 3pF in addition to PCB routing.

14 MDU – Multiply Divide Unit

The MDU – Multiplication Division Unit, is an on-chip arithmetic co-processor which enables the MCU to perform additional extended arithmetic operations like 32-bit division, 16-bit multiplication, shift and, normalize operations.

14.1 Features

The MDU is controlled by the SFR registers MD0.. MD5 and ARCON.

14.2 Block diagram

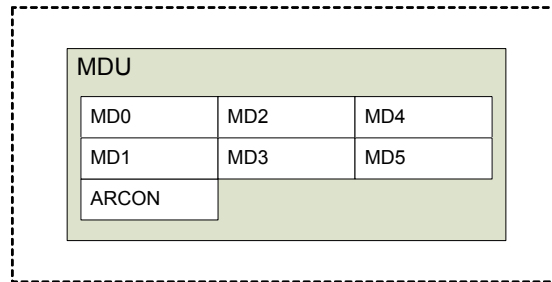

Figure 56. Block diagram of MDU

14.3 Functional description

All operations are unsigned integer operations. The MDU is handled by seven registers, which are memory mapped as Special Function Registers. The arithmetic unit allows concurrent operations to be performed independent of the MCU's activity.

Operands and results are stored in MD0.. MD5 registers. The module is controlled by the ARCON register. Any calculation of the MDU overwrites its operands.

The MDU does not allow reentrant code and cannot be used in multiple threads of the main and interrupt routines at the same time. Use the NOMDU_R515 compile directive to disable MDU operation in possible conflicting functions.

14.4 SFR registers

The MD0.. MD5 are registers used in the MDU operation.

Address	Register name
0xE9	MD0
0xEA	MD1
0xEB	MD2
0xEC	MD3
0xED	MD4
0xEE	MD5

Table 67. Multiplication/Division registers MD0..MD5

The ARCON register controls the operation of MDU and informs you about its current state.

Address	Reset value	Bit	Name	Description
0xEF	0x00	7	mdef	MDU Error flag MDEF. Indicates an improperly performed operation (when one of the arithmetic operations has been restarted or interrupted by a new operation).
		6	mdov	MDU Overflow flag MDOV. Overflow occurrence in the MDU operation.
		5	slr	Shift direction, 0: shift left, 1: shift right.
		4-0	sc	Shift counter. When set to '0's, normalize operation is selected. After normalization, the "sc.0" ... "sc.4" contains the number of normalizing shifts performed. Shift operation is selected when at least one of these bits is set high. The number of shifts performed is determined by the number written to "sc.4" .., "sc.0", where "sc.4" is the MSB.

Table 68. ARCON register

The operation of the MDU consists of the following phases:

14.4.1 Loading the MDx registers

The type of calculation the MDU has to perform is selected in accordance with the order in which the MDx registers are written.

Operation	32 bit/16 bit		16 bit / 16 bit		16 bit x 16 bit		Shift/normalize	
first write	MD0 (lsb)	Dividend	MD0 (lsb)	Dividend	MD0 (lsb)	Num1	MD0 (lsb)	Number
	MD1				MD1 (msb)	MD4 (lsb)		
last write	MD2	Divisor	MD4 (lsb)	Divisor	MD1 (msb)	Num1	ARCON	
	MD3 (msb)				MD5 (msb)	MD5 (msb)		

Table 69. MDU registers write sequence

1. Write MD0 to start any operation.
2. Write operations, as shown in [Table 69](#), to determine appropriate MDU operation.
3. Write (to MD5 or ARCON) starts selected operation.

The SFR Control detects some of the above sequences and passes control to the MDU. When a write access occurs to MD2 or MD3 between write accesses to MD0 and finally to MD5, then a 32/16 bit division is selected.

When a write access to MD4 or MD1 occurs before writing to MD5, then a 16/16 bit division or 16x16 bit multiplication is selected. Writing to MD4 selects 16/16 bit division and writing to MD1 selects 16x16 bit multiplication, that is, Num1 x Num2.

14.4.2 Executing calculation

During executing operation, the MDU works on its own in parallel with the MCU.

Operation	Number of clock cycles	
Division 32bit/16bit	17 clock cycles	
Division 16bit/16bit	9 clock cycles	
Multiplication	11 clock cycles	
Shift	min. 3 clock cycles (sc = 01h)	max 18 clock cycles (sc = 1Fh)
Normalize	min. 4 clock cycles (sc <- 01h)	max 19 clock cycles (sc <- 1Fh)

Table 70. MDU operations execution times

14.4.3 Reading the result from the MDx registers

Operation	32 bit/16 bit		16 bit / 16 bit		16 bit x 16 bit		Shift/normalize	
first read	MD0 (lsb) MD1 MD2 MD3 (msb)	Quotient	MD0 (lsb) MD1 (msb)	Quotient	MD0 (lsb) MD1 MD2	Product	MD0 (lsb) MD1 MD2	Number
last read	MD4 (lsb) MD5 (msb)	Remainder	MD4 (lsb) MD5 (msb)	Remainder	MD3 (msb)		MD3 (msb)	

Table 71. MDU registers read sequence

The Read out sequence of the first MDx registers is not critical but the last read (from MD5 - division and MD3 - multiplication, shift or normalize) determines the end of a whole calculation (end of phase three).

14.4.4 Normalizing

All leading zeroes of 32-bit integer variable stored in the MD0.. MD3 registers are removed by shift left operations. The whole operation is completed when the MSB (Most Significant Bit) of MD3 register contains a '1'. After normalizing, bits ARCON[4] (msb) .. ARCON[0] (lsb) contain the number of shift left operations that were done.

14.4.5 Shifting

In shift operation, 32-bit integer variable stored in the MD0... MD3 registers (the latter contains the most significant byte) is shifted left or right by a specified number of bits. The slr bit (ARCON[5]) defines the shift direction and bits ARCON[4]... ARCON[0] specify the shift count (which must not be 0). During shift operation, zeroes come into the left end of MD3 for shifting right or they come in the right end of the MD0 for shifting left.

14.4.6 The mdef flag

The mdef error flag (see [Table 68. on page 125](#)) indicates an improperly performed operation (when one of the arithmetic operations is restarted or interrupted by a new operation). The error flag mechanism is automatically enabled with the first write operation to MD0 and disabled with the final read instruction from MD3 (multiplication or shift/norm) or MD5 (division) in phase three.

The error flag is set when:

- If you write to MD0.. MD5 and/or ARCON during phase two of MDU operation (restart or calculations interrupting).
- If any of the MDx registers are read during phase two of MDU operation when the error flag mechanism is enabled. In this case, the error flag is set but the calculation is not interrupted.

The error flag is reset only after read access to the ARCON register. The error flag is read only.

14.4.7 The mdov flag

The mdov overflow flag (see [Table 68. on page 125](#)) is set when one of the following conditions occurs:

- division by zero.
- multiplication with a result greater than 0000 FFFFh.
- start of normalizing if the most significant bit of MD3 is set (“md3.7” = ‘1’).

Any operation of the MDU that does not match the above conditions clears the overflow flag.

Note: The overflow flag is exclusively controlled by hardware, it cannot be written.

15 Encryption/decryption accelerator

You can utilize the on-chip encryption/decryption accelerator for more time and power effective firmware. The accelerator is an 8 by 8 Galois Field Multiplier with an 8 bits output. The following polynomial is used:

$$m(x) = x^8 + x^4 + x^3 + x + 1$$

This is the polynomial used by AES (Advanced Encryption Standard).

15.1 Features

- Firmware available from Nordic Semiconductor.
- The result from the co-processing is available one clock period after the input data registers have changed.

15.2 Block diagram

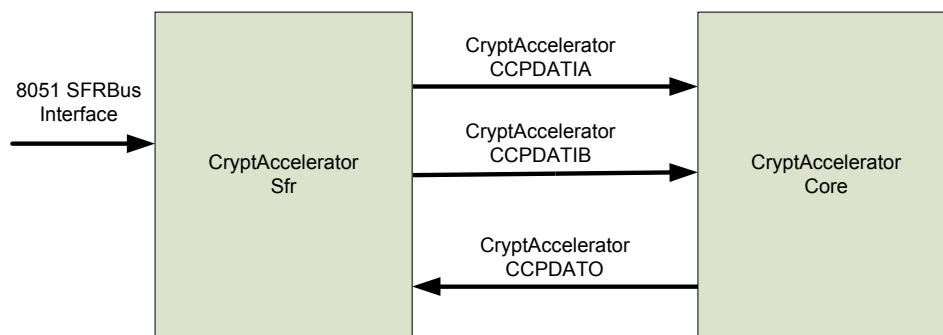

Figure 57. Encryption/decryption accelerator

15.3 Functional description

The following registers control the encryption/decryption accelerator.

Address (Hex)	Name/Mnemonic	Bit	Reset values	Type	Description
0xDD	CCPDATIA	7:0	0x00	R/W	Encryption/decryption accelerator data in register A.
0xDE	CCPDATIB	7:0	0x00	R/W	Encryption/decryption accelerator data in register B.
0xDF	CCPDATO	7:0	0x00	R	Encryption/decryption accelerator data out register.

Table 72. Encryption/decryption accelerator registers

The two registers `CCPDATIA` and `CCPDATIB` contain the input data, whilst `CCPDATO` contains the result from the co-processing. `CCPDATO` is updated one clock period after one of the input data registers has changed.

16 Random number generator

The nRF24LE1 contains a true Random Number Generator (RNG), which uses thermal noise to produce a non-deterministic bitstream. A digital corrector algorithm is employed on the bitstream to remove any bias toward ‘1’ or ‘0’. The bits are then queued into an 8-bit register for parallel readout.

16.1 Features

- Non-deterministic architecture based on thermal noise
- No seed value required
- Non-repeating sequence
- Corrector algorithm ensures uniform statistical distribution
- Data rate up to 10 kilobytes per second
- Operational while the processor is in standby

16.2 Block diagram

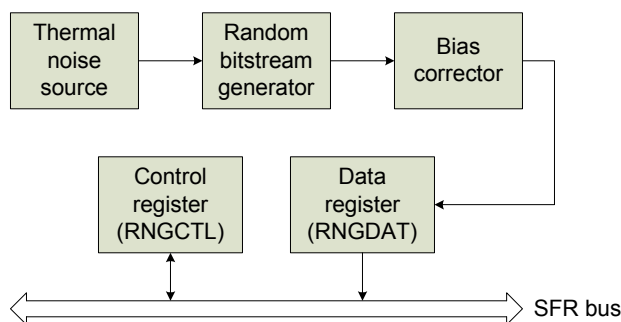

Figure 58. Block diagram of RNG

16.3 Functional description

Write a ‘1’ to the `powerUp` control bit to start the generator. The `resultReady` status bit flags when a random byte is available for readout in the `RNGDAT` register. It will be cleared when the data has been read, and set again when a new byte is ready. An interrupt (`RNGIRQ`) is also produced each time a new byte has been generated. The behavior of the interrupt is the same as that of the `resultReady` status bit.

The random data and the `resultReady` status bit are invalid and should not be used when the RNG is powered down. When the RNG is powered up, by writing a ‘1’ to the `powerUp` control bit, the random data and the `resultReady` status bit are cleared regardless of whether the random data has been read or not.

It is possible to disable the bias corrector by clearing the `correctorEn` bit. This offers a substantial speed advantage, but may yield a statistical distribution that is not perfectly uniform.

The time needed to generate one byte of data is unpredictable, and may vary from one byte to the next. This is especially true when the corrector is enabled. It takes about 0.1ms on average to generate one byte when the corrector is disabled, and four times as long when it is enabled. There is an additional start-up delay of about 0.25ms for the first byte, counted from when the `powerUp` control bit is set.

16.4 SFR registers

The RNG is interfaced through the two registers; RNGCTL and RNGDAT. RNGCTL contains control bits and a status bit. RNGDAT contains the random data.

Addr	Bit	name	RW	Function	Reset value: 0x40
0xD6	7	powerUp	RW	Power up RNG	
	6	correctorEn	RW	Enable bias corrector	
	5	resultReady	R	Data ready flag. Set when a fresh random byte is available in the RNGDAT register. Cleared when the byte has been read and when the RNG comes out of powerdown (when the powerUp bit changes from 0 to 1).	
	4:0	-	-	Not used	

Table 73. RNGCTL register

Addr	Bit	name	RW	Function	Reset value: 0x00
0xD7	7:0	data	R	Random data	

Table 74. RNGDAT register

17 General purpose IO port and pin assignments

The IO pins of the nRF24LE1 are default set to general purpose IO for the MCU. The numbers of available IOs are 7 for the 24 pin 4×4mm, 15 for the 32 pin 5×5mm and 31 for the 48 pin 7×7mm package. The IO pins are also shared with IO requirements from peripheral blocks like SPI and 2 wire as well as more specialized functions like a 32 kHz crystal oscillator and the JTAG interface for the HW debugger. Connections between these other peripheral blocks and the pins are made dynamically by the PortCrossbar module.

17.1 Block diagram

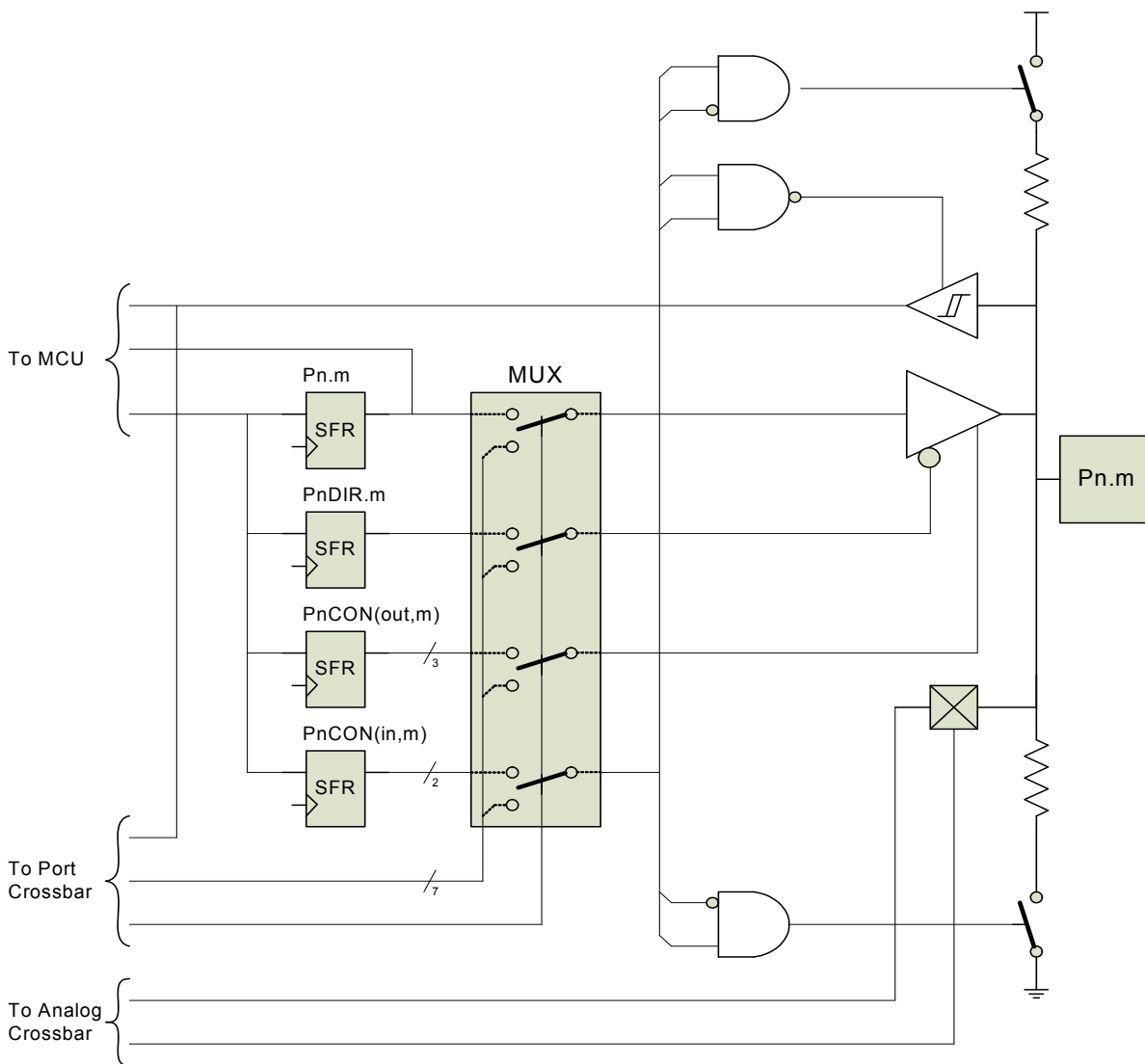

Figure 59. IO pin circuitry block diagram

17.2 Functional description

17.2.1 General purpose IO pin functionality

Each of the IO pins on nRF24LE1 has a generic control functionality that sets pin features for the GPIO of the MCU.

The features offered by the pins include:

- Digital or Analog
- Configurable Direction
- Configurable Drive Strength
- Configurable Pull Up/Down

This functionality is multiplexed with the functionality of the PortCrossbar module which takes control and configures the pins depending on the needs of the peripheral block connected. The pin circuitry of the nRF24LE1 is shown in [Figure 59](#).

The pins on the nRF24LE1 are connected by default to a pin Multiplexer (MUX) that is connected to the GPIO registers of the MCU. Register $Pn.m$ (n-port number, m - bit number) contains MCU GPIO data, $PDIRn.m$ register controls input/output direction and $PCONn.m$ register controls pin features drive strength and pull up/down resistors for each pin.

When the MCU enables one of the peripheral blocks of the nRF24LE1 the pin MUX disconnects the MCU control of the pin and hands control over to the PortCrossbar module to set direction and pin features.

However, if the pin is operated as an analog input, the MCU must set the pin control registers $PDIR$ and $PCON$ separately to prevent conflicts between pin configuration and the needs of the analog peripheral blocks of the nRF24LE1.

The nRF24LE1 has one $Pn.m$, $PnDIRm$ and $PnCONn$ for each port. $Pn.m$ and $PnDIRm$ control only one parameter each, this means that a write/read operation to them controls/reads the status of the port directly. However, to control or read the features of a pin you use the $PnCONm$ to write/read to one pin at a time. The $PnCON$ register contains an address for the pin, information on whether it is an input or an output feature that is to be updated and the feature that is to be enabled.

The features available:

- Output buffer on, normal drive strength
- Output buffer on, high drive strength
- Input buffer on, no pull up/down resistor
- Input buffer on, pull up resistor
- Input buffer on, pull down resistor
- Input buffer off

Example: If four pins in port 3 are set as inputs with the pull up resistor enabled, then this is done with one write to $P3DIR$ and four write operations to $P3CON$ and only updating the pin address in $P3CON$ for each write.

17.2.2 PortCrossbar functionality

The PortCrossbar sets up connections between the IO pins and the peripheral block of the device.

17.2.2.1 Dynamic allocation of pins

The PortCrossbar modifies connections dynamically based on run-time variations in system needs of the peripheral blocks (SPI, 2 wire etc) of the device. This feature is necessary because the number of available pins is small compared to the combined IO needs of all the peripheral blocks. Consequently, on the smaller package options there may be conflicting pin assignments. These are resolved through a set of priorities assigned to each peripheral block. The pin out tables for each package option can be seen in [Table 75. on page 136](#), [Table 76. on page 137](#) and [Table 77. on page 140](#).

17.2.2.2 Dynamic pin allocation for digital blocks

Each digital peripheral block that needs an IO is represented in the pin out tables with the interface names of the block and the direction enforced on each pin. The priority of the blocks relative to potentially conflicting blocks is also shown. If the block is enabled, and no higher priority block is enabled, all the IO needs are granted. The PortCrossbar never grants partial fulfilment of a digital IO request even if a conflict exists only for some of the pins. A requesting digital device gets all or none of its IO needs granted.

17.2.2.3 Dynamic pin allocation for analog blocks

A dynamic request for analog IO is similar to that of a digital IO. However, for analog blocks only the interface signals actually used as inputs to the analog blocks, configured by ADCCON1.chsel and ADCCON1.refsel, are connected to a device pin. This is different from the digital peripheral blocks where all the IO of a block are reserved once the block is enabled.

The two analog blocks, ADC and analog comparator, share a column in the pin out tables. This is done because the comparator uses the ADC configuration registers for selecting the source pins for its signal and voltage reference inputs. Please refer to [chapter 21 on page 165](#) and [chapter 22 on page 171](#) for more details.

Note: The implementation does not prevent simultaneous digital and analog use of a pin. If a pin is to be used for analog input, digital I/O buffers and digital peripheral blocks connected to the same pin should normally be disabled. Conflicts between analog blocks are resolved through priority.

The IO needs of the XOSC32K are also run-time programmable. Depending on configuration, this block may request either analog or digital IO. See [section 13.3.4 on page 122](#) for further details.

If analog functionality is enabled for a pin, this is done without modifying or disabling the pins digital configuration. If particular digital input and/or output configuration are necessary for an analog pin to function correctly, this configuration must be enabled in registers P_xCON and P_xDIR separately, before enabling the analog block.

17.2.2.4 Default pin allocation

If no peripheral blocks request IO, a default pinout as listed in the default column in the pin out maps are enabled. This means that all device pins are used for MCU GPIO. After reset, all IOs are configured to be digital inputs. The features, direction and IO data on the pins are in this case controlled by registers P_nCON, P_nDIR and P_n.

The default pin out also includes connections that are conditionally enabled based on the direction set for the pin. For example, if the `P0DIR` register in a 24pin 4x4mm package sets pin P0.6 as an input, it can be used as a MCU GP input and as the UART receiver. If pin P0.5 is programmed as an output, it can be connected to the MCU as a GP output, but also have conditional output from the UART/TXD through an AND gate.

17.3 IO pin maps

The following conventions are used in all pin out maps:

- For dynamic connections of digital peripheral blocks, the direction of each pin is indicated by 'in', 'out' or 'inout' next to the interface name.
- Dynamic analog connections are indicated with 'ana'.
- Digital peripheral blocks with potentially conflicting IO needs are highlighted with blue background in the pinout tables.
- For blocks marked with a green background, conflicts may exist with other green and blue devices, depending on the configuration. Please refer to the documentation of the configurable (green) blocks for information on how the configuration affects the IO usage.
- The relative priorities of competing digital peripheral blocks are listed in the table header.

17.3.1 Pin assignments in package 24 pin 4x4 mm

The connection map described in this chapter is valid for nRF24LE1 in the 24 pin 4x4 mm package. Pins P0.0, P0.2, P0.4 and P0.6 have two system inputs listed per pin. This means that the input from the pin is driving both blocks inputs through an AND gate when the pin is configured as an input. Pin P0.5 and P0.6 are listed with two system outputs, such as p0Do 5 and UART/TXD. In these two cases the Port-Crossbar also combines the two drivers using an AND gate and lets the AND gate drive the pin if it is configured as an output. The AND gate is chosen since both the UART/TXD and UARAT/RXD signals are high when idle.

The SMISO pin driver is only enabled when the SCSN pin is active.

Pin	Default connections		Dynamically enabled connections											
	Inputs ^a	Outputs ^a	XOSC32K	SPI Master	Slave/Flash SPI		HW Debug		2-Wire		PWM		ADC/COMP	
			priority 1	priority 2	priority 3		priority 4		priority 5		priority 6		priority 7	
P0.6	p0Di.6 UART/ RXD	p0Do.6					OCITO	out	W2SDA	inout	PWM1	out	AIN6	ana
P0.5	p0Di.5 UART/ TXD	p0Do.5			SCSN	in	OCITDO	out	W2SCL	inout			AIN5	ana
					FCSN ^b	in								
P0.4	p0Di.4 T0	p0Do.4		MMISO	in	SMISO	out	OCITDI	in				AIN4	ana
						FMISO ^a	out							
P0.3	p0Di.3	p0Do.3		MMOSI	out	SMOSI	in	OCITMS	in			PWM0	out	AIN3
						FMOSI ^a	in							
P0.2	p0Di.2 GPINT1	p0Do.2		MSCK	out	SSCK	in	OCITCK	in				AIN2	ana
						FSCK ^a	in							
P0.1	p0Di.1	p0Do.1	CLKLF ^c										AIN1	ana
P0.0	p0Di.0 GPINT0	p0Do.0	CLKLF ^d	ana									AIN0	ana
	Conflict exists, use priorities to determine IO allocation													
	Conflict may exist depending on device configuration. In the case of a conflict, use priorities to determine IO allocation													

- a. The bit prefixes p<x>Di and p<x>Do indicate normal functionality for the inputs and outputs of pin <x>.
- b. Flash SPI interface only activated when PROG is set high, no conflict with runtime operations
- c. Connection depends on configuration register CLKLFCTRL[2:0]
 CLKLFCTRL[2:09] = 000: Crystal connected between pin P0.0 and pin P0.1.
 CLKLFCTRL[2:0] = 011: Low-amplitude clock source for CLKLF from analog connection pin P0.1.
 CLKLFCTRL[2:0] = 100: Digital clock source for CLKLF.
- d. Connection depends on configuration register CLKLFCTRL[2:0]
 CLKLFCTRL[2:0] = 000: Crystal connected between pin P0.0 and pin P0.1.

Table 75. Pin out map for the 24 pin 4x4mm package

17.3.2 Pin assignments in package 32 pin 5x5 mm

The connection map described in this chapter is valid with the 32-pin 5x5 QFN package. Pins P0.4 to P1.0 have two system inputs listed per pin. This means that the input from the pin is driving both block inputs if the pin is configured as an input.

Pins P0.3-P0.4 are listed with two system outputs, such as p0Do 3 and TXD. In these two cases the Port-Crossbar combines the two drivers using an AND gate and lets the AND gate drive the pin if it is configured as an output. The AND gate is chosen since both the TXD and RXD signals are high when idle. The SMISO pin driver is enabled only when SCSN is active.

pin	Default connections		Dynamically enabled connections													
	Inputs	Outputs	XOSC32K		SPI Master		Slave/Flash SPI		PWM		ADC/COMP		HW Debug		2-Wire	
			priority 1		priority 2		priority 3		priority 4		priority 5		priority 6		priority 7	
P1.6	p1Di.6	p1Do.6			MMISO	in										
P1.5	p1Di.5	p1Do.5			MMOSI	out										
P1.4	p1Di.4	p1Do.4			MOSCK	out										
P1.3	p1Di.3	p1Do.3											OCITO	out		
P1.2	p1Di.2	p1Do.2									AIN10	ana	OCITDO	out		
P1.1	p1Di.1	p1Do.1					SCSN	in			AIN 9	ana	OCITDI	in		
					FCSN ^a	in										
P1.0	p1Di.0 T1	p1Do.0					SMISO	out			AIN 8	ana	OCITMS	in		
					FMISO ^a	out										
P0.7	p0Di.7 T0	p0Do.7					SMOSI	in			AIN 7	ana	OCITCK	in		
					FMOSI ^a	in										
P0.6	p0Di.6 GPINT1	p0Do.6									AIN 6	ana				
P0.5	p0Di.5 GPINT0	p0Do.5					SSCK	in			AIN 5	ana			W2SDA	inout
							FSCK ^a	in								
P0.4	p0Di.4 UART/ RXD	p0Do.4									AIN 4	ana			W2SCL	inout
P0.3	p0Di.3	p0Do.3							PWM1	out	AIN 3	ana				
		UART/ TXD														
P0.2	p0Di.2	p0Do.2							PWM0	out	AIN 2	ana				
P0.1	p0Di.1	p0Do.1	CLKLF ^b								AIN1	ana				
P0.0	p0Di.0	p0Do.0	CLKLF ^c	ana							AIN0	ana				
Conflict exists, use priorities to determine IO allocation																
Conflict may exist depending on device configuration. In the case of a conflict, use priorities to determine IO allocation																

- a. Flash SPI interface only activated when PROG is set high, no conflict with runtime operations.
- b. Connection depends on configuration register CLKLFCTRL[2:0]
 CLKLFCTRL[2:0] = 000: Crystal connected between pin P0.0 and pin P0.1.
 CLKLFCTRL[2:0] = 011: Low-amplitude clock source for CLKLF from pin P0.1.
 CLKLFCTRL[2:0] = 100: Digital clock source for CLKLF.
- c. Connection depends on configuration register CLKLFCTRL[2:0]
 CLKLFCTRL[2:0] = 000: Crystal connected between pin P0.0 and pin P0.1.

Table 76. Pin out map for the 32 pin 5x5mm package

17.3.3 Pin assignments in package 48 pin 7x7 mm

Due to the pin count in this package no IO conflicts exists between digital peripheral blocks. Pins P1.1-P1.7 have two system inputs listed per pin. This means that the input from the pin is driving both system inputs if the pin is configured as an input.

Pins P1.0-P1.1 are listed with two system outputs, such as p1Do 1 and TXD. In these two cases the Port-Crossbar combines the two drivers using an AND gate and lets the AND gate drive the pin if it is configured as an output. The AND gate is chosen since both the TXD and RXD signals are high when idle. The SMISO pin driver is enabled only when SCSN is active.

Pin	Default connections		Dynamically enabled connections													
	Inputs	Outputs	XOSC32K		ADC/COMP		SPI Master		Slave/Flash SPI		PWM		HW Debug		2-Wire	
			priority 1		priority 4		priority 2				priority 6		priority 5		priority 7	
P3.6	p3Di.6	p3Do.6														
P3.5	p3Di.5	p3Do.5														
P3.4	p3Di.4	p3Do.4														
P3.3	p3Di.3	p3Do.3														
P3.2	p3Di.2	p3Do.2														
P3.1	p3Di.1	p3Do.1														
P3.0	p3Di.0	p3Do.0														
P2.7	p2Di.7	p2Do.7														
P2.6	p2Di.6	p2Do.6														
P2.5	p2Di.5	p2Do.5														
P2.4	p2Di.4	p2Do.4														
P2.3	p2Di.3	p2Do.3														
P2.2	p2Di.2	p2Do.2														
P2.1	p2Di.1	p2Do.1														
P2.0	p2Di.0	p2Do.0							FCSN ^a	in						
P1.7	p1Di.7	p1Do.7														
P1.6	p1Di.6	p1Do.6							FMISO ^a	out						
P1.5	p1Di.5	p1Do.5			AIN13	ana			FMOSI ^a	in		OCITO	out			
P1.4	p1Di.4	p1Do.4			AIN12	ana						OCITDO	out			
P1.3	p1Di.3	p1Do.3			AIN11	ana						OCITDI	in	W2SDA	inout	
P1.2	p1Di.2	p1Do.2			AIN10	ana			FSCCK ^a	in		OCITMS	in	W2SCL	inout	
P1.1	p1Di.1	p1Do.1			AIN9	ana						OCITCK	in			
P1.0	p1Di.0	p1Do.0			AIN8	ana	MMISO	in								
P0.7	p0Di.7	p0Do.7			AIN7	ana	MMOSI	out			PWM0	out				
P0.6	p0Di.6	p0Do.6			AIN6	ana	MSCK	out			PWM1	out				
P0.5	p0Di.5	p0Do.5			AIN5	ana			SCSN	in						
P0.4	p0Di.4	p0Do.4			AIN4	ana			SMISO	out						
P0.3	p0Di.3	p0Do.3			AIN3	ana			SMOSI	in						
P0.2	p0Di.2	p0Do.2			AIN2	ana			SSCK	in						
P0.1	p0Di.1	p0Do.1	CLKLF ^b		AIN1	ana										
P0.0	p0Di.0	p0Do.0	CLKLF ^c	ana	AIN0	ana										
Conflict may exist depending on device configuration. In the case of a conflict, use priorities to determine IO allocation.																

- a. Flash SPI interface only activated when **PROG** is set high, no conflict with runtime operations.
- b. Connection depends on configuration register CLKLFCTRL[2:0]
 CLKLFCTRL[2:0] = 000: Crystal connected between pin **P0.0** and pin **P0.1**.
 CLKLFCTRL[2:0] = 011: Low-amplitude clock source for CLKLF from pin **P0.1**.
 CLKLFCTRL[2:0] = 100: Digital clock source for CLKLF.

- c. Connection depends on configuration register CLKLFCTRL[2:0]
CLKLFCTRL[2:0] = 000: Crystal connected between pin P0.0 and pin P0.1.

Table 77. Pin out map for the 48 pin 7x7mm package

17.3.4 Programmable registers

Depending on the package size 1 to 4 ports are available on nRF24LE1. Desired pin direction and functionality is configured using the configuration registers P0DIR, P1DIR, P2DIR, P3DIR, collectively referred to as PxDIR, and P0CON, P1CON, P2CON and P3CON, referred to as PxCON. The PxDIR registers determine the direction of the pins and the PxCON registers contain the functional options for input and output pin operation.

The PortCrossbar by default (at reset) configures all pins as inputs and connects them to the MCU GPIO (pxDi).

To change pin direction, write the desired direction to the PxDIR registers.

Register name: P0DIR			Address: 0x93	Reset value: 0xFF
Bit	Name	RW	Function	
7:0	dir	RW	Direction bits for pins P0.0 - P0.7. Output: dir = 0, Input: dir = 1. P0DIR 0 - P0.0 P0DIR 1 - P0.1 P0DIR 2 - P0.2 P0DIR 3 - P0.3 P0DIR 4 - P0.4 P0DIR 5 - P0.5 P0DIR 6 - P0.6 P0DIR 7 - P0.7 P0.7 only available on packages 32pin 5x5mm and 48pin 7x7mm	

Table 78. P0DIR register

Register name: P1DIR			Address: 0x94	Reset value: 0xFF
Bit	name	RW	Function	
7:0	dir	RW	Direction bits for pins P1.0 - P1.7. Output: dir = 0, Input: dir = 1. P1DIR 0 - P1.0 P1DIR 1 - P1.1 P1DIR 2 - P1.2 P1DIR 3 - P1.3 P1DIR 4 - P1.4 P1DIR 5 - P1.5 P1DIR 6 - P1.6 P1DIR 7 - P1.7 Port1 only available on packages 32 pin 5x5mm and 48 pin 7x7mm P1.7 only available on package 48 pin 7x7	

Table 79. P1DIR register

Register name: P2DIR			Address: 0x95	Reset value: 0xFF
Bit	Name	RW	Function	
7:0	dir	RW	Direction bits for pins P2.0 – P2.7. (Not used by the 5×5mm package). Output: dir = 0, Input: dir = 1. P2DIR 0 - P2.0 P2DIR 1 - P2.1 P2DIR 2 - P2.2 P2DIR 3 - P2.3 P2DIR 4 - P2.4 P2DIR 5 - P2.5 P2DIR 6 - P2.6 P2DIR 7 - P2.7 Port2 only available on package 48 pin 7×7mm	

Table 80. P2DIR register

Register name: P3DIR			Address: 0x96	Reset value: 0xFF
Bit	Name	RW	Function	
7:0	dir	RW	Direction bits for pins P3.0 – P3.6. (Not used by the 5×5mm package). Output: dir = 0, Input: dir = 1. P3DIR 0 - P3.0 P3DIR 1 - P3.1 P3DIR 2 - P3.2 P3DIR 3 - P3.3 P3DIR 4 - P3.4 P3DIR 5 - P3.5 P3DIR 6 - P3.6 P3DIR 7 - reserved Port 3 only available on package 48 pin 7×7mm	

Table 81. P3DIR register

The input and output options of each pin are configured in the PxCON registers. The PxCON registers have to be written once per pin (one write operation to the PxCON register configures the input/output options of a selected pin in the port).

To read the current input or output options for a pin, you first need to perform a write operation to retrieve the desired bit address and option type (input or output).

For instance, to read the output mode of pin P0.5: Write to P0CON with a bitAddr value of the binary number 101, a readAddr value of 1 and a inOut value of 0 (output). Then read from P0CON. The output mode of pin 5 is now found in bits 7:5 of the read data.

Register name: P0CON			Address: 0x9E	Reset value: 0x00																																													
Bit	Name	RW	Function																																														
7:5	pinMode	RW	<p>Functional input or output mode for pins P0.0 – P0.7.</p> <p>For a write operation: The functional mode you would like to write to the pin. The inOut field determines if the input or output mode is written, the bitAddr field determines which pin is affected.</p> <p>Output modes using bits 7:5: 000 Digital output buffer normal drive strength 011 Digital output buffer high drive strength (all other value combinations are illegal)</p> <p>Input modes using bits 6:5: 00 Digital input buffer on, no pull up/down resistors 01 Digital input buffer on, pull down resistor connected 10 Digital input buffer on, pull up resistor connected 11 Digital input buffer off</p> <p>For a read operation: The current functional mode of the pin. The inOut field determines if the input or output mode is reported, while the bitAddr field indicates which pin is selected.</p>																																														
4	inOut	W	<p>This bit indicates if the current write operation relates to the input or output configuration of the addressed pin.</p> <p>inOut = 0 - Operate on the output configuration inOut = 1 - Operate on the input configuration</p>																																														
3	readAddr	W	<p>If this bit is set, the purpose of the current write operation is to provide the bit address for later read operations. Consequently, the value of the bitAddr field is saved. The value of the inOut field is also saved, determining if the input or output mode is to be read. The pinMode field is ignored when readAddr is set.</p> <p>If this bit is not set, the pin mode of the addressed pin is updated with the value of the pinMode field. The inOut field determines if the input or output mode is updated.</p>																																														
2:0	bitAddr	W	<p>If the readAddr bit is set, the value of the bitAddr field is stored. For subsequent read operations from P0CON, the pin for which the pinMode will be returned is given by the list below.</p> <table border="0" style="margin-left: auto; margin-right: auto;"> <tr> <td></td> <td></td> <td style="text-align: center;">7×7mm</td> <td style="text-align: center;">5×5mm</td> <td style="text-align: center;">4×4mm</td> </tr> <tr> <td>bitAddr =</td> <td>000 - P0.0</td> <td style="text-align: center;">P0.0</td> <td style="text-align: center;">P0.0</td> <td style="text-align: center;">P0.0</td> </tr> <tr> <td>bitAddr =</td> <td>001 - P0.1</td> <td style="text-align: center;">P0.1</td> <td style="text-align: center;">P0.1</td> <td style="text-align: center;">P0.1</td> </tr> <tr> <td>bitAddr =</td> <td>010 - P0.2</td> <td style="text-align: center;">P0.2</td> <td style="text-align: center;">P0.2</td> <td style="text-align: center;">P0.2</td> </tr> <tr> <td>bitAddr =</td> <td>011 - P0.3</td> <td style="text-align: center;">P0.3</td> <td style="text-align: center;">P0.3</td> <td style="text-align: center;">P0.3</td> </tr> <tr> <td>bitAddr =</td> <td>100 - P0.4</td> <td style="text-align: center;">P0.4</td> <td style="text-align: center;">P0.4</td> <td style="text-align: center;">P0.4</td> </tr> <tr> <td>bitAddr =</td> <td>101 - P0.5</td> <td style="text-align: center;">P0.5</td> <td style="text-align: center;">P0.5</td> <td style="text-align: center;">P0.5</td> </tr> <tr> <td>bitAddr =</td> <td>110 - P0.6</td> <td style="text-align: center;">P0.6</td> <td style="text-align: center;">P0.6</td> <td style="text-align: center;">P0.6</td> </tr> <tr> <td>bitAddr =</td> <td>111 - P0.7</td> <td style="text-align: center;">P0.7</td> <td style="text-align: center;">P0.7</td> <td style="text-align: center;">reserved</td> </tr> </table>				7×7mm	5×5mm	4×4mm	bitAddr =	000 - P0.0	P0.0	P0.0	P0.0	bitAddr =	001 - P0.1	P0.1	P0.1	P0.1	bitAddr =	010 - P0.2	P0.2	P0.2	P0.2	bitAddr =	011 - P0.3	P0.3	P0.3	P0.3	bitAddr =	100 - P0.4	P0.4	P0.4	P0.4	bitAddr =	101 - P0.5	P0.5	P0.5	P0.5	bitAddr =	110 - P0.6	P0.6	P0.6	P0.6	bitAddr =	111 - P0.7	P0.7	P0.7	reserved
		7×7mm	5×5mm	4×4mm																																													
bitAddr =	000 - P0.0	P0.0	P0.0	P0.0																																													
bitAddr =	001 - P0.1	P0.1	P0.1	P0.1																																													
bitAddr =	010 - P0.2	P0.2	P0.2	P0.2																																													
bitAddr =	011 - P0.3	P0.3	P0.3	P0.3																																													
bitAddr =	100 - P0.4	P0.4	P0.4	P0.4																																													
bitAddr =	101 - P0.5	P0.5	P0.5	P0.5																																													
bitAddr =	110 - P0.6	P0.6	P0.6	P0.6																																													
bitAddr =	111 - P0.7	P0.7	P0.7	reserved																																													

Table 82. P0CON register

Register name: P1CON			Address: 0x9F	Reset value: 0x00																																				
Bit	Name	RW	Function																																					
7:5	pinMode	RW	<p>Functional input or output mode for pins P1.0 – P1.7.</p> <p>For a write operation: The functional mode you would like to write to the pin. The inOut field determines if the input or output mode is written, the bitAddr field determines which pin is affected.</p> <p>Output modes using bits 7:5: 000 Digital output buffer normal drive strength 011 Digital output buffer high drive strength (all other value combinations are illegal)</p> <p>Input modes using bits 6:5: 00 Digital input buffer on, no pull up/down resistors 01 Digital input buffer on, pull down resistor connected 10 Digital input buffer on, pull up resistor connected 11 Digital input buffer off</p> <p>For a read operation: The current functional mode of the pin. The inOut field determines if the input or output mode is reported, while the bitAddr field indicates which pin is selected.</p>																																					
4	inOut	W	<p>This bit indicates if the current write operation relates to the input or output configuration of the addressed pin.</p> <p>inOut = 0 - Operate on the output configuration inOut = 1 - Operate on the input configuration</p>																																					
3	readAddr	W	<p>If this bit is set, the purpose of the current write operation is to provide the bit address for later read operations. Consequently, the value of the bitAddr field is saved. The value of the inOut field is also saved, determining if the input or output mode is to be read. The pinMode field is ignored when readAddr is set.</p> <p>If this bit is not set, the pin mode of the addressed pin is updated with the value of the pinMode field. The inOut field determines if the input or output mode is updated.</p>																																					
2:0	bitAddr	W	<p>If the readAddr bit is set, the value of the bitAddr field is stored. For subsequent read operations from P1CON, the pin for which the pinMode will be returned, is given by the list below.</p> <table border="0" style="margin-left: auto; margin-right: auto;"> <tr> <td></td> <td style="text-align: center;">7×7mm</td> <td style="text-align: center;">5×5mm</td> <td style="text-align: center;">4×4mm</td> </tr> <tr> <td>bitAddr = 000</td> <td>- P1.0</td> <td>P1.0</td> <td>reserved</td> </tr> <tr> <td>bitAddr = 001</td> <td>- P1.1</td> <td>P1.1</td> <td>reserved</td> </tr> <tr> <td>bitAddr = 010</td> <td>- P1.2</td> <td>P1.2</td> <td>reserved</td> </tr> <tr> <td>bitAddr = 011</td> <td>- P1.3</td> <td>P1.3</td> <td>reserved</td> </tr> <tr> <td>bitAddr = 100</td> <td>- P1.4</td> <td>P1.4</td> <td>reserved</td> </tr> <tr> <td>bitAddr = 101</td> <td>- P1.5</td> <td>P1.5</td> <td>reserved</td> </tr> <tr> <td>bitAddr = 110</td> <td>- P1.6</td> <td>P1.6</td> <td>reserved</td> </tr> <tr> <td>bitAddr = 111</td> <td>- P1.7</td> <td>reserved</td> <td>reserved</td> </tr> </table>			7×7mm	5×5mm	4×4mm	bitAddr = 000	- P1.0	P1.0	reserved	bitAddr = 001	- P1.1	P1.1	reserved	bitAddr = 010	- P1.2	P1.2	reserved	bitAddr = 011	- P1.3	P1.3	reserved	bitAddr = 100	- P1.4	P1.4	reserved	bitAddr = 101	- P1.5	P1.5	reserved	bitAddr = 110	- P1.6	P1.6	reserved	bitAddr = 111	- P1.7	reserved	reserved
	7×7mm	5×5mm	4×4mm																																					
bitAddr = 000	- P1.0	P1.0	reserved																																					
bitAddr = 001	- P1.1	P1.1	reserved																																					
bitAddr = 010	- P1.2	P1.2	reserved																																					
bitAddr = 011	- P1.3	P1.3	reserved																																					
bitAddr = 100	- P1.4	P1.4	reserved																																					
bitAddr = 101	- P1.5	P1.5	reserved																																					
bitAddr = 110	- P1.6	P1.6	reserved																																					
bitAddr = 111	- P1.7	reserved	reserved																																					

Table 83. P1CON register

Register name: P2CON			Address: 0x97	Reset value: 0x00																																													
Bit	Name	RW	Function																																														
7:5	pinMode	RW	<p>Functional input or output mode for pins P2.0 – P2.7. (Not used by the 5×5mm package).</p> <p>For a write operation: The functional mode you would like to write to the pin. The inOut field determines if the input or output mode is written, the bitAddr field determines which pin is affected.</p> <p>Output modes using bits 7:5: 000 Digital output buffer normal drive strength 011 Digital output buffer high drive strength (all other value combinations are illegal)</p> <p>Input modes using bits 6:5: 00 Digital input buffer on, no pull up/down resistors 01 Digital input buffer on, pull down resistor connected 10 Digital input buffer on, pull up resistor connected 11 Digital input buffer off</p> <p>For a read operation: The current functional mode of the pin. The inOut field determines if the input or output mode is reported, while the bitAddr field indicates which pin is selected.</p>																																														
4	inOut	W	<p>This bit indicates if the current write operation relates to the input or output configuration of the addressed pin.</p> <p>inOut = 0 - Operate on the output configuration inOut = 1 - Operate on the input configuration</p>																																														
3	readAddr	W	<p>If this bit is set, the purpose of the current write operation is to provide the bit address for later read operations. Consequently, the value of the bitAddr field is saved. The value of the inOut field is also saved, determining if the input or output mode is to be read. The pinMode field is ignored when readAddr is set.</p> <p>If this bit is not set, the pin mode of the addressed pin is updated with the value of the pinMode field. The inOut field determines if the input or output mode is updated.</p>																																														
2:0	bitAddr	W	<p>If the readAddr bit is set, the value of the bitAddr field is stored. For subsequent read operations from P2CON, the pin for which the pinMode will be returned, is given by the list below.</p> <table border="0" style="width: 100%; text-align: center;"> <tr> <td></td> <td></td> <td>7×7mm</td> <td>5×5mm</td> <td>4×4mm</td> </tr> <tr> <td>bitAddr =</td> <td>000</td> <td>- P2.0</td> <td>reserved</td> <td>reserved</td> </tr> <tr> <td>bitAddr =</td> <td>001</td> <td>- P2.1</td> <td>reserved</td> <td>reserved</td> </tr> <tr> <td>bitAddr =</td> <td>010</td> <td>- P2.2</td> <td>reserved</td> <td>reserved</td> </tr> <tr> <td>bitAddr =</td> <td>011</td> <td>- P2.3</td> <td>reserved</td> <td>reserved</td> </tr> <tr> <td>bitAddr =</td> <td>100</td> <td>- P2.4</td> <td>reserved</td> <td>reserved</td> </tr> <tr> <td>bitAddr =</td> <td>101</td> <td>- P2.5</td> <td>reserved</td> <td>reserved</td> </tr> <tr> <td>bitAddr =</td> <td>110</td> <td>- P2.6</td> <td>reserved</td> <td>reserved</td> </tr> <tr> <td>bitAddr =</td> <td>111</td> <td>- P2.7</td> <td>reserved</td> <td>reserved</td> </tr> </table>				7×7mm	5×5mm	4×4mm	bitAddr =	000	- P2.0	reserved	reserved	bitAddr =	001	- P2.1	reserved	reserved	bitAddr =	010	- P2.2	reserved	reserved	bitAddr =	011	- P2.3	reserved	reserved	bitAddr =	100	- P2.4	reserved	reserved	bitAddr =	101	- P2.5	reserved	reserved	bitAddr =	110	- P2.6	reserved	reserved	bitAddr =	111	- P2.7	reserved	reserved
		7×7mm	5×5mm	4×4mm																																													
bitAddr =	000	- P2.0	reserved	reserved																																													
bitAddr =	001	- P2.1	reserved	reserved																																													
bitAddr =	010	- P2.2	reserved	reserved																																													
bitAddr =	011	- P2.3	reserved	reserved																																													
bitAddr =	100	- P2.4	reserved	reserved																																													
bitAddr =	101	- P2.5	reserved	reserved																																													
bitAddr =	110	- P2.6	reserved	reserved																																													
bitAddr =	111	- P2.7	reserved	reserved																																													

Table 84. P2CON register

Register name: P3CON			Address: 0x8F	Reset value: 0x00																																													
Bit	Name	RW	Function																																														
7:5	pinMode	RW	<p>Functional input or output mode for pins P3.0 – P3.6. (Not used by the 5×5mm package).</p> <p>For a write operation: The functional mode you would like to write to the pin. The inOut field determines if the input or output mode is written, the bitAddr field determines which pin is affected.</p> <p>Output modes using bits 7:5: 000 Digital output buffer normal drive strength 011 Digital output buffer high drive strength (all other value combinations are illegal)</p> <p>Input modes using bits 6:5: 00 Digital input buffer on, no pull up/down resistors 01 Digital input buffer on, pull down resistor connected 10 Digital input buffer on, pull up resistor connected 11 Digital input buffer off</p> <p>For a read operation: The current functional mode of the pin. The inOut field determines if the input or output mode is reported, while the bitAddr field indicates which pin is selected.</p>																																														
4	inOut	W	<p>This bit indicates if the current write operation relates to the input or output configuration of the addressed pin.</p> <p>inOut = 0 - Operate on the output configuration inOut = 1 - Operate on the input configuration</p>																																														
3	readAddr	W	<p>If this bit is set, the purpose of the current write operation is to provide the bit address for later read operations. Consequently, the value of the bitAddr field is saved. The value of the inOut field is also saved, determining if the input or output mode is to be read. The pinMode field is ignored when readAddr is set.</p> <p>If this bit is not set, the pin mode of the addressed pin is updated with the value of the pinMode field. The inOut field determines if the input or output mode is updated.</p>																																														
2:0	bitAddr	W	<p>If the readAddr bit is set, the value of the bitAddr field is stored. For subsequent read operations from P3CON, the pin for which the pinMode will be returned, is given by the list below.</p> <table border="0" style="margin-left: auto; margin-right: auto;"> <tr> <td></td> <td></td> <td style="text-align: center;">7×7mm</td> <td style="text-align: center;">5×5mm</td> <td style="text-align: center;">4×4mm</td> </tr> <tr> <td>bitAddr =</td> <td>000 - P3.0</td> <td></td> <td>reserved</td> <td>reserved</td> </tr> <tr> <td>bitAddr =</td> <td>001 - P3.1</td> <td></td> <td>reserved</td> <td>reserved</td> </tr> <tr> <td>bitAddr =</td> <td>010 - P3.2</td> <td></td> <td>reserved</td> <td>reserved</td> </tr> <tr> <td>bitAddr =</td> <td>011 - P3.3</td> <td></td> <td>reserved</td> <td>reserved</td> </tr> <tr> <td>bitAddr =</td> <td>100 - P3.4</td> <td></td> <td>reserved</td> <td>reserved</td> </tr> <tr> <td>bitAddr =</td> <td>101 - P3.5</td> <td></td> <td>reserved</td> <td>reserved</td> </tr> <tr> <td>bitAddr =</td> <td>110 - P3.6</td> <td></td> <td>reserved</td> <td>reserved</td> </tr> <tr> <td>bitAddr =</td> <td>111 - reserved</td> <td></td> <td>reserved</td> <td>reserved</td> </tr> </table>				7×7mm	5×5mm	4×4mm	bitAddr =	000 - P3.0		reserved	reserved	bitAddr =	001 - P3.1		reserved	reserved	bitAddr =	010 - P3.2		reserved	reserved	bitAddr =	011 - P3.3		reserved	reserved	bitAddr =	100 - P3.4		reserved	reserved	bitAddr =	101 - P3.5		reserved	reserved	bitAddr =	110 - P3.6		reserved	reserved	bitAddr =	111 - reserved		reserved	reserved
		7×7mm	5×5mm	4×4mm																																													
bitAddr =	000 - P3.0		reserved	reserved																																													
bitAddr =	001 - P3.1		reserved	reserved																																													
bitAddr =	010 - P3.2		reserved	reserved																																													
bitAddr =	011 - P3.3		reserved	reserved																																													
bitAddr =	100 - P3.4		reserved	reserved																																													
bitAddr =	101 - P3.5		reserved	reserved																																													
bitAddr =	110 - P3.6		reserved	reserved																																													
bitAddr =	111 - reserved		reserved	reserved																																													

Table 85. P3CON register

While the IO ports are used as MCU GPIO, the pin values are read and controlled by the MCU port registers P3 to P0.

Address	Name	Bit	Reset value	Type	Description
0xB0	P3	7:0	0xFF	R/W	Port 3 value
0xA0	P2	7:0	0xFF	R/W	Port 2 value
0x90	P1	7:0	0xFF	R/W	Port 1 value
0x80	P0	7:0	0xFF	R/W	Port 0 value

Table 86. P3-P0 registers

How many ports are available depends on which of the three nRF24LE1 package sizes you are using.

18 SPI

nRF24LE1 features a double buffered Serial Peripheral Interface (SPI). You can configure it to work in all four SPI modes. The default is mode 0.

The SPI connects to the following pins of the device: **MMISO**, **MMOSI**, **MSCK**, **SCSN**, **SMISO**, **SMOSI** and **SSCK**.

The SPI Master function does not generate any chip select signal (CSN). The programmer typically uses another programmable digital I/O to act as chip selects for one or more external SPI Slave devices.

18.1 Features

- Double buffered FIFO
- Full-duplex operation
- Supports SPI modes 0 through 3
- Configurable data order on xMISO/xMOSI
- Four (Master) and three (Slave) interrupt sources

18.2 Block diagram

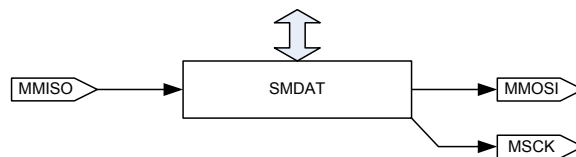

Figure 60. SPI Master

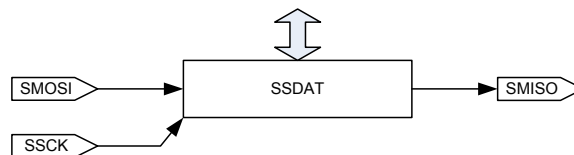

Figure 61. SPI Slave

18.3 Functional description

18.3.1 SPI master

The following registers control the SPI master:

Address (Hex)	Name/mnemonic	Bit	Reset value	Type	Description
0xFC	SPIMCON0	6:0	0x20	R/W	SPI Master configuration register 0.
	clockFrequency	6:4	010	R/W	Frequency on MSCK. ckMCU is the MCU clock frequency.) 000: 1/2 ·ckMCU 001: 1/4 ·ckMCU 010: 1/8 ·ckMCU 011: 1/16·ckMCU 100: 1/32·ckMCU 101: 1/64·ckMCU 110: 1/64·ckMCU 111: 1/64·ckMCU
	dataOrder	3	0	R/W	Data order (bit wise per byte) on serial output and input (MMOSI and MMISO respectively). 1: LSBit first, MSBit last. 0: MSBit first, LSBit last.
	clockPolarity	2	0	R/W	Defines the SPI Master's operating mode together with SPIMCON0.1, see chapter 18.3.3 Slave SPI timing . 1: MSCK is active 'low'. 0: MSCK is active 'high'.
	clockPhase	1	0	R/W	Defines the SPI Master's operating mode together with SPIMCON0.2, see chapter 18.3.3 Slave SPI timing . 1: Sample on trailing edge of MSCK, shift on leading edge. 0: Sample on leading edge of MSCK, shift on trailing edge.
	spiMasterEnable	0	0	R/W	1: SPI Master is enabled. The clock to the SPI Master core functionality is running. An SPI transfer can be initiated by the MCU via the 8051 SFR Bus (TX). 0: SPI Master is disabled. The clock to the SPI Master core functionality stands still.
0xFD	SPIMCON1	3:0	0x0F	R/W	SPI Master configuration register 1.
	maskIrqRx Fifo Full	3	1	R/W	1: Disable interrupt when RX FIFO is full. 0: Enable interrupt when RX FIFO is full.
	maskIrqRx Data Ready	2	1	R/W	1: Disable interrupt when data is available in RX FIFO. 0: Enable interrupt when data is available in RX FIFO.
	maskIrqTx Fifo Empty	1	1	R/W	1: Disable interrupt when TX FIFO is empty. 0: Enable interrupt when TX FIFO is empty.

Address (Hex)	Name/mnemonic	Bit	Reset value	Type	Description
	maskIrqTxFifo-Ready	0	1	R/W	1: Disable interrupt when a location is available in TX FIFO. 0: Enable interrupt when a location is available in TX FIFO.
0xFE	SPIMSTAT	3:0	0x03	R	SPI Master status register.
	rxFifoFull	3	0	R	Interrupt source. 1: RX FIFO full. 0: RX FIFO can accept more data from SPI. Cleared when the cause is removed.
	rxDataReady	2	0	R	Interrupt source. 1: Data available in RX FIFO. 0: No data in RX FIFO. Cleared when the cause is removed.
	txFifoEmpty	1	1	R	Interrupt source. 1: TX FIFO empty. 0: Data in TX FIFO. Cleared when the cause is removed.
	txFifoReady	0	1	R	Interrupt source. 1: Location available in TX FIFO. 0: TX FIFO full. Cleared when the cause is removed.
0xFF	SPIMDAT	7:0	0x00	R/W	SPI Master data register. Accesses TX (write) and RX (read) FIFO buffers, both two bytes deep.

Table 87. SPI Master registers

The SPI Master is configured through `SPIMCON0` and `SPIMCON1`. It is enabled by setting `SPIMCON0[0]` to '1'. The SPI Master supports all four SPI modes, selected by `SPIMCON0[2]` and `SPIMCON0[1]` as described in [section 18.3.3](#). The bit wise data order per byte on MMISO/MMOSI is defined by `SPIMCON0[3]`. MCK can run on one of six predefined frequencies in the range of 1/2 to 1/64 of the MCU clock frequency, as defined by `SPIMCON0[6]` down to `SPIMCON0[4]`.

`SPIMDAT` accesses both the TX (write) and the RX (read) FIFOs, which are two bytes deep. The FIFOs are dynamic and can be refilled according to the state of the status flags: "FIFO ready" means that the FIFO can accept data. "Data ready" means that the FIFO can provide data, minimum one byte.

Four different sources can generate interrupt, unless they are masked by their respective bits in `SPIMCON1`. `SPIMSTAT` reveals which sources are active.

18.3.2 SPI slave

The following registers control the SPI slave:

Address (Hex)	Name/mnemonic	Bit	Reset value	Type	Description
0xBC	SPISCON0	6:0	0x70	R/W	SPI Slave configuration register 0
	<i>maskIrqCsnHigh</i>	6	1	R/W	1: Disable interrupt when SCSN goes high. 0: Enable interrupt when SCSN goes high.
	<i>maskIrqCsnLow</i>	5	1	R/W	1: Disable interrupt when SCSN goes low. 0: Enable interrupt when SCSN goes low.
	<i>maskIrqSpiSlaveDone</i>	4	1	R/W	1: Disable interrupt when SPI Slave is done with the current SPI transaction.” 0: Enable interrupt when SPI Slave is done with the current SPI transaction.
	<i>dataOrder</i>	3	0	R/W	Data order (bit wise per byte) on serial input and output (SMOSI and SMISO, respectively.) 1: LSBit first, MSBit last. 0: MSBit first, LSBit last.
	<i>clockPolarity</i>	2	0	R/W	Defines the SPI Slave’s operating mode together with with SPISCON0.1, see chapter 18.3.3 Slave SPI timing . 1: SSCK is active ‘low’. 0: SSCK is active ‘high’.
	<i>clockPhase</i>	1	0	R/W	Defines the SPI Slave’s operating mode together with with SPISCON0.2, see chapter 18.3.3 Slave SPI timing . 1: Sample on trailing edge of SSCK, shift on leading edge. 0: Sample on leading edge of SSCK, shift on trailing edge.
	<i>spiSlaveEnable</i>	0	0	R/W	1: SPI Slave is enabled. The clock to the SPI Slave core functionality is running. An SPI transfer can be initiated by an SPI Master (RX). 0: SPI Slave is disabled. The clock to the SPI Slave core functionality stands still.
0xBE	SPISTAT	5:0	0x00	R	SPI Slave status register
	<i>csnHigh</i>	5	0	R	Interrupt source. 1: Positive edge of SCSN detected 0: Positive edge of SCSN not detected. Cleared when read.
	<i>csnLow</i>	4	0	R	Interrupt source 1: Negative edge of SCSN detected 0: Negative edge of SCSN not detected. Cleared when read.
	<Reserved>	3:1	-	-	-
	<i>spiSlaveDone</i>	0	0	R	Interrupt source. 1: SPI Slave done with an SPI transaction. 0: SPI Slave not done with an SPI transaction. Cleared when read.
0xBF	SPISDAT	7:0	0x00	R/W	SPI Slave data register. Accesses the RX (read)/TX (write) buffers.

Table 88. SPI Slave registers

The SPI slave is configured through `SPISCON0`. It is enabled by setting `SPISCON0.0` to ‘1’. The SPI Slave supports all four SPI modes, selected by `SPISCON0.2` and `SPISCON0.1` as described in [section 18.3.3](#).

The bit wise data order per byte on SMISO/SMOSI is defined by `SPISCON0`. 3. There are three possible interrupt sources in the SPI Slave. Any one of them can be masked.

When an interrupt occurs, `SPISSTAT` provides information on what the source was.

`SPISDAT` is used for data access in both directions. Prior to the first clock from the external SPI master, the MCU can write a up to two bytes to `SPISDAT`, but only one before `SCSN` goes low. The first byte will be transferred from the external SPI Master to the Slave on `SMISO` while data is being transferred from the external Master to the Slave on `SMOSI`. For maximum data throuput, after the first byte has been transferred, software must ensure that there always are two bytes in the TX chain; one that is being transferred and another in the pipe. There are two ways of doing this:

1. Preload *two* TX data bytes as described above, and then one byte for each *Spi Slave done* interrupt until the transfer is completed.
2. Preload *one* TX data byte as described above, load two bytes at the first *Spi Slave done* interrupt and then one byte for each *Spi Slave done* interrupt until the transfer is completed. This approach is, for some of the highest SSCK frequencies, likely to require a pause between the first and the second bytes on SPI, giving the MCU time to load the next TX data.

18.3.3 Slave SPI timing

The four different SPI modes are presented in [Table 89. SPI modes](#), [Figure 62](#), and [Figure 63](#).

SPI mode	clockPolarity	clockPhase	Clock shift edge		Clock sample edge	
0	0	0	Trailing	Falling	Leading	Rising
1	0	1	Leading	Rising	Trailing	Falling
2	1	0	Trailing	Rising	Leading	Falling
3	1	1	Leading	Falling	Trailing	Rising

Table 89. SPI modes

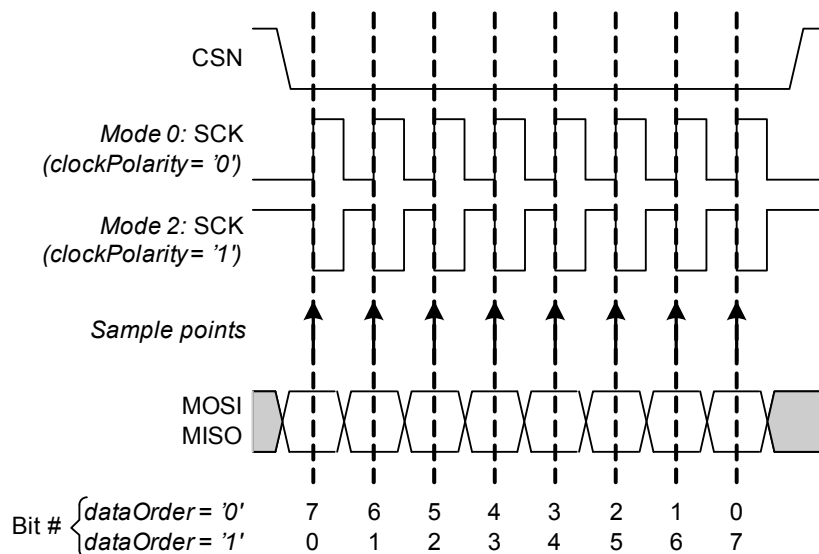

Figure 62. SPI Modes 0 and 2: clockPhase = '0'. One byte transmission.

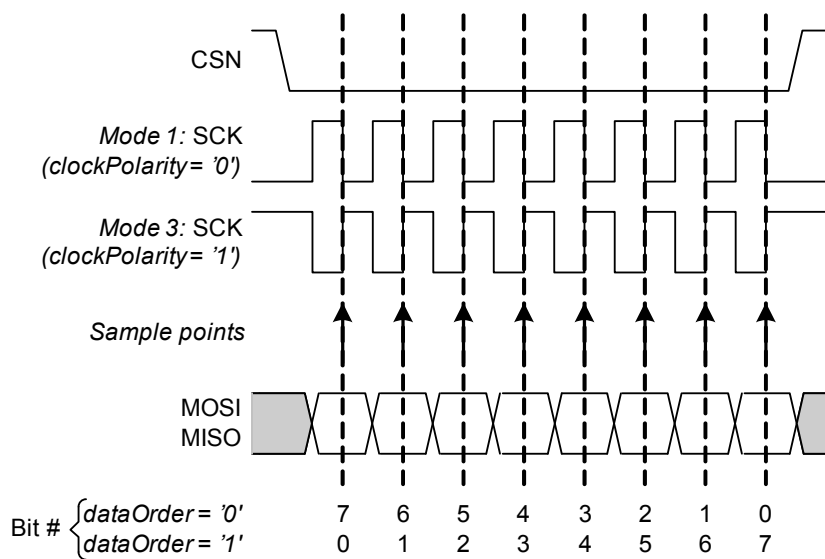

Figure 63. SPI Modes 1 and 3: clockPhase = '1'. One byte transmission.

SPI timing is given in [Figure 64.](#) and in [Table 90.](#) and [Table 91.](#)

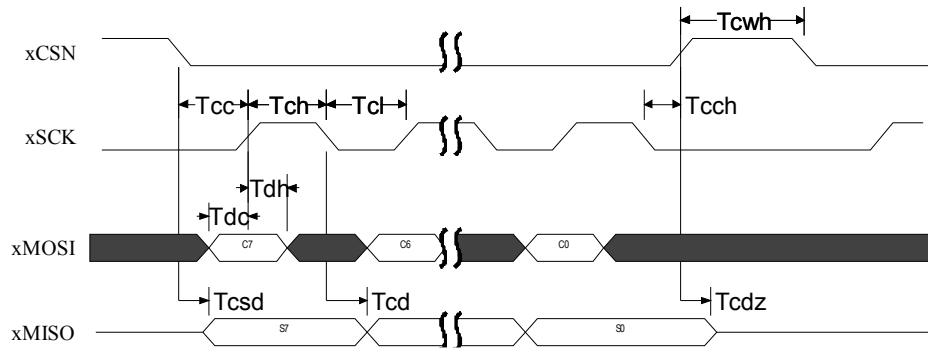

Figure 64. SPI timing diagram. One byte transmission.

Parameters	Symbol	Min	Max	Units
Data to SCK Setup	T _{dc}	2		ns
SCK to Data Hold	T _{dh}	2		ns
CSN to Data Valid	T _{csd}		38	ns
SCK to Data Valid	T _{cd}		55	ns
SCK Low Time	T _{cl}	40		ns
SCK High Time	T _{ch}	40		ns
SCK Frequency	F _{sck}	0	8	MHz
SCK Rise and Fall	T _r ,T _f		100	ns
CSN to SCK Setup	T _{cc}	2		ns
SCK to CSN Hold	T _{cch}	2		ns
CSN Inactive time	T _{cwh}	50		ns
CSN to Output High Z	T _{cdz}		38	ns

Table 90. SPI timing parameters ($C_{Load} = 5pF$)

Parameters	Symbol	Min	Max	Units
Data to SCK Setup	T _{dc}	2		ns
SCK to Data Hold	T _{dh}	2		ns
CSN to Data Valid	T _{csd}		42	ns
SCK to Data Valid	T _{cd}		58	ns
SCK Low Time	T _{cl}	40		ns
SCK High Time	T _{ch}	40		ns
SCK Frequency	F _{sck}	0	8	MHz
SCK Rise and Fall	T _r ,T _f		100	ns
CSN to SCK Setup	T _{cc}	2		ns
SCK to CSN Hold	T _{cch}	2		ns
CSN Inactive time	T _{cwh}	50		ns
CSN to Output High Z	T _{cdz}		42	ns

Table 91. SPI timing parameters ($C_{Load} = 10pF$)

19 Serial port (UART)

The MCU system is configured with one serial port that is identical in operation to the standard 8051 serial port (Serial interface 0). The two serial port signals RXD and TXD are available on device pins UART/RSD and UART/TXD

The serial port (UART) derives its clock from the MCU clock; `ckCpu`. See [chapter 11.3.1 on page 110](#) for more information. The direction for the UART pins must be set to input for the RXD pin and output for the TXD pin in the corresponding `PxDIR` registers.

19.1 Features

- Synchronous mode, fixed baud rate
- 8-bit UART mode, variable baud rate
- 9-bit UART mode, variable baud rate
- 9-bit UART mode, fixed baud rate
- Additional baud rate generator

Note: It is not recommended to use Timer 1 overflow as baud generator.

19.2 Block diagram

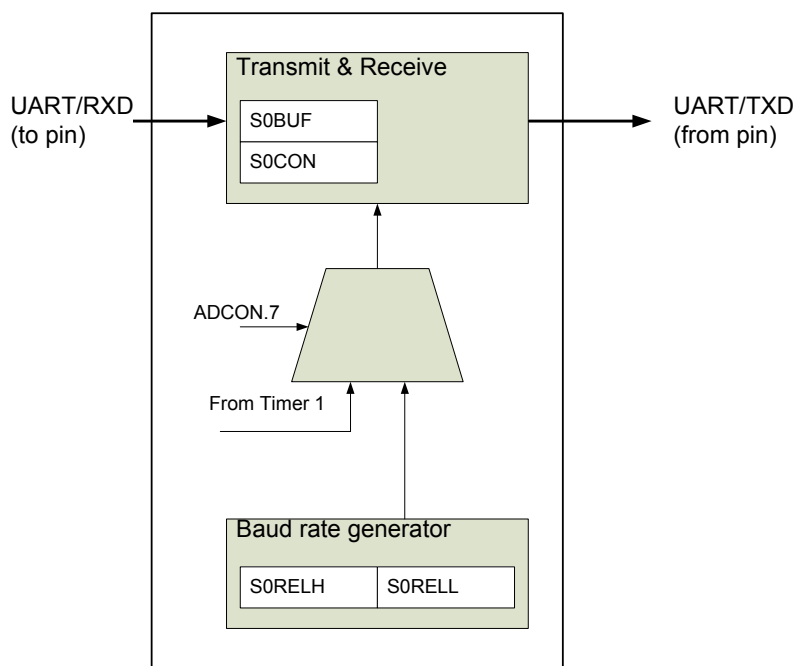

Figure 65. Block diagram of serial port

19.3 Functional description

The serial port is controlled by `S0CON`, while the actual data transferred is read or written in the `S0BUF` register. Transmission speed ("baud rate") is selected using the `S0RELL`, `S0RELH` and `ADCON` registers.

19.3.1 Serial port 0 control register – S0CON

The S0CON register controls the function of Serial Port 0.

Address	Reset value	Bit	Name	Description
0x98	0x00	7:6	sm0: sm1	Serial Port 0 mode select 0 0: Mode 0 – Shift register at baud rate ckCpu / 12 0 1: Mode 1 – 8-bit UART. 1 0: Mode 2 – 9-bit UART at baud rate ckCpu /32 or ckCpu/64 ^a 1 1: Mode 3 – 9 bit UART.
		5	sm20	Multiprocessor communication enable
		4	ren0	Serial reception enable: 1: Enable Serial Port 0.
		3	tb80	Transmitter bit 8. This bit is used while transmitting data through Serial Port 0 in Modes 2 and 3. The state of this bit corresponds with the state of the 9th transmitted bit (for example, parity check or multiprocessor communication). It is controlled by software.
		2	rb80	Received bit 8. This bit is used while receiving data through Serial Port 0 in Modes 2 and 3. It reflects the state of the 9th received bit.
		1	ti0	Transmit interrupt flag. It indicates completion of a serial transmission at Serial Port 0. It is set by hardware at the end of bit 8 in mode 0 or at the beginning of a stop bit in other modes. It must be cleared by software.
		0	ri0	Receive interrupt flag. It is set by hardware after completion of a serial reception at Serial Port 0. It is set by hardware at the end of bit 8 in mode 0 or in the middle of a stop bit in other modes. It must be cleared by software.

a. If smod = 0 baud rate is ckCpu/64, if smod = 1 then baud rate is ckCpu/32.

Table 92. S0CON register

Table 93. shows registers settings for some common UART baud rates.

Baud rate	Cclk	SMOD	s0rel
600	16 MHz	1	0x00BF
1200	16 MHz	1	0x025F
2400	16 MHz	1	0x0330
4800	16 MHz	1	0x0398
9600	16 MHz	1	0x03CC
19200	16 MHz	1	0x03E6
38400	16 MHz	1	0x03F3

Table 93. Register settings for selected baud rates

To configure other baud rates, please use the formulas in [Figure 66. on page 157.](#)

for bd ($adcon$ [7]) = 0:

$$baud\ rate = \frac{2^{SMOD} * ckCpu}{32} * (Timer\ 1\ overflow\ rate)$$

for bd ($adcon$ [7]) = 1:

$$baud\ rate = \frac{2^{SMOD} * ckCpu}{64 * (2^{10} - s0rel)}$$

Figure 66. Equation of baud rate settings for Serial Port 0

Below is an explanation of some of the values used in [Figure 66](#):

Value	Definition
SMOD (PCON[7])	Serial Port 0 baud rate select flag
S0REL	The contents of S0REL registers (s0relh, s0rell) see section 19.3.3 .
bd (adcon[7])	The MSB of ADCON register see section 19.3.4

Table 94. Values of S0CON equation

19.3.2 Serial port 0 data buffer – S0BUF

Address	Reset value	Register name
0x99	0x00	S0BUF

Table 95. S0BUF register

Writing data to the S0BUF register sets data in serial output buffer and starts the transmission through Serial Port 0. Reading from the S0BUF reads data from the serial receive buffer.

19.3.3 Serial port 0 reload register – S0RELH, S0RELL

Serial Port 0 Reload register is used for Serial Port 0 baud rate generation. Only 10 bits are used, 8 bits from the S0RELL, and 2 bits from the S0RELH.

Address	Reset value	Register name
0xAA	0xD9	S0RELL
0xBA	0x03	S0RELH

Table 96. S0RELL/S0RELH register

19.3.4 Serial port 0 baud rate select register - ADCON

The MSB of this register is used by Serial Port 0 for baud rate generation.

Address	Reset value	Bit	Name	Description
0xD8	0x00	7	bd	Serial Port 0 baud rate select (in modes 1 and 3) When 1, additional internal baud rate generator is used, otherwise Timer 1 overflow is used.
		6-0		Not used

Table 97. ADCON register

20 2-Wire

The nRF24LE1 has a single buffered 2-Wire interface. It can be configured to transmit or receive data as master or slave, at two different data rates. The 2-Wire is not CBUS compatible.

The 2 wire interface connects to device pins `W2SDA` and `W2SCL`.

20.1 Features

- I2C compatible
- Single buffered
- Half-duplex operation
- Supports four modes: Master transmitter, Master receiver, Slave transmitter and Slave receiver
- Supports two baud rates: Standard mode (100 Kbit/s) and Fast mode (400 Kbit/s)
- Supports broadcast
- Supports 7-bit addressing
- Supports Slave stall of serial clock (SCL)

20.2 Functional description

20.2.1 Recommended use

- The `wire2Enable` bit (`w2CON0[0]`) must be set to '1' in a separate write operation before any other programming of the 2-Wire is attempted.
- If the clockstop feature is used, the `clockStop` bit (`w2CON0[6]`) should be set to '1' before transmissions begin. In clockStop mode, all received data must be read from the `w2DAT` register, even received addresses. This is necessary to avoid stalling the 2-Wire bus.
- Updates to the `maskIrq` configuration bit (`w2CON1[5]`) should be performed before transmission begins.
- Once a '1' has been written to the `xStart` bit (`w2CON0[4]`) or the `xStop` bit (`w2CON0[5]`), the user should not attempt to cancel the request by clearing the bit at a later time.

20.2.2 Master transmitter/receiver

A new transfer is initiated by entering a start condition. This can be done by setting `w2CON0[4]` to '1', or simply by writing the first byte to `w2DAT`. The first byte is always transmitted from the Master.

20.2.2.1 TX mode

To enter TX mode, MCU must write the address to the Slave it wants the 2-Wire to connect to, or the general call address (0x00), to `w2DAT[7:1]`, and write '0' to the direction bit; `w2DAT[0]`. The byte is then transmitted to the Slave(s). If not masked, an interrupt request is asserted on the rising edge of SCL following the last bit in the byte. Simultaneously, the acknowledge from the addressed Slave is stored in `w2CON1[1]`. 2-Wire is then ready to accept TX data from the MCU, and the bitwise transmissions will follow the same procedure as for the first byte.

To do a repeated start, the MCU must set `w2CON0[4]` before writing a new Slave address and direction bit to `w2DAT`. To stop the transfer, it must write '1' to `w2CON0[5]` after writing the last TX data byte to `w2DAT`. Start and stop conditions have lower priorities than pending TX data, that is, `w2CON0[4]` and `w2CON0[5]` can be set immediately after the last TX data write. If both bits are set, the stop condition is transmitted first.

20.2.2.2 RX mode

To enter RX mode, MCU must write the address to the Slave it wants the 2-Wire to connect to, to `W2DAT[7:1]`, and write '1' to the direction bit; `W2DAT[0]`. The byte is then transmitted to the Slave(s). If not masked, an interrupt request is asserted on the rising edge of SCL following the last bit in the byte. Simultaneously, the acknowledge from the addressed Slave is stored in `W2CON1[1]`. The 2-Wire then releases the control over the bus and is ready to accept bitwise RX data from the addressed Slave. For each byte received, if not masked, an interrupt request is asserted at the same time as the last bit is sampled, prior to sending the acknowledge to the Slave. The acknowledge is also stored in `W2CON1[1]`.

To do a repeated start or stop the transfer, the MCU must set `W2CON0[5]` after receiving the second to last byte from the Slave. This makes the 2-Wire Master send a not-acknowledge after the last byte, which forces the Slave to let go of the bus control. After receiving the last byte, the Master can do a repeated start by writing a new Slave address and direction bit to `W2DAT`.

20.2.3 Slave transmitter/receiver

As the 2-Wire Slave detects a start condition it will enter RX mode and wait for the first byte from the Master. When the first byte is completed, the Slave compares `W2DAT[7]` down to `W2DAT[1]` to `W2SADR` (or the general call address, 0x00) to see if it is supposed to reply. If so, `W2DAT[0]` decides if it should stay in RX mode ('0') or enter TX mode ('1').

The 2-Wire Slave asserts interrupt requests to the MCU when 1) there is an address match after a start condition; 2) after each data byte received (RX mode) or transmitted (TX mode), or; 3) a stop condition is detected. All interrupts can be masked by configuration.

If the 2-Wire Slave's MCU has trouble processing the data fast enough, it can stall the transmission by setting `W2CON0[6]` to '1' between bytes. In TX mode, this forces SCL 'low' after transmission until the MCU has written new data to `W2DAT`. In RX mode, SCL is kept 'low' after reception, until the MCU has read the new data.

New TX data must always be written by the MCU to `W2DAT` before the next falling edge on SCL.

New RX data must always be read by the MCU from `W2DAT` before the next rising edge on SCL, after the corresponding interrupt request.

20.2.3.1 2-Wire timing

Symbol	Parameter (CK = 16 MHz)	Standard		Fast		Unit
		Min	Max	Min	Max	
f_{CK}	System clock frequency.	16		16		MHz
CK_{PERIOD}	System clock period.	62.5		62.5		ns
SCL_{PERIOD}	SCL clock period.	10000		2500		ns
$t_{STA2SCL0}$	Time from start condition to SCL goes 'low'.		4700		940	ns
t_{SCL0F}	SCL 'low' time after start condition.	5000		1250		ns
t_{DSETUP}	Data setup time before positive edge on SCL.	4400		800		ns
t_{DHOLD}	Data hold time after negative edge on SCL.	$3 \cdot CK_P$	560	$3 \cdot CK_P$	440	ns
t_{SCL0L}	SCL 'low' time after last bit before stop condition.	5000		1250		ns
$t_{SCL12STOP}$	Time from SCL goes 'high' to stop condition.	5000		1300		ns
$t_{STOP2START}$	Time from stop condition to start condition.	4700		1000		ns
t_{REL}	Time from change on SDA until SCL is released when the module is a Slave that forces SCL 'low'.	1400		1400		ns
WIRQ	Width of IRQ signal.	$4 \cdot CK_P$		$4 \cdot CK_P$		ns
P2IRQ	Time from positive edge on SCL to IRQ signal.	$9 \cdot CK_P$		$8 \cdot CK_P$		ns

Table 98. Timing (16 MHz system clock)

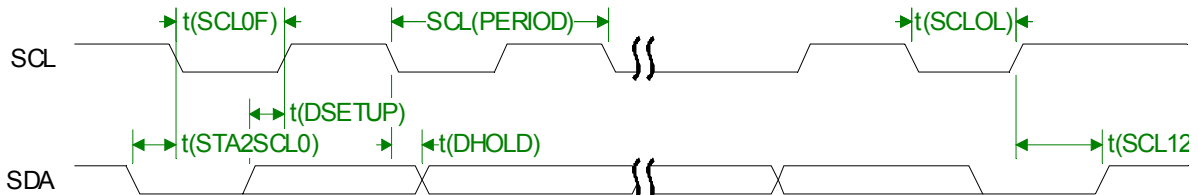

Figure 67. Timing SCL/SDA

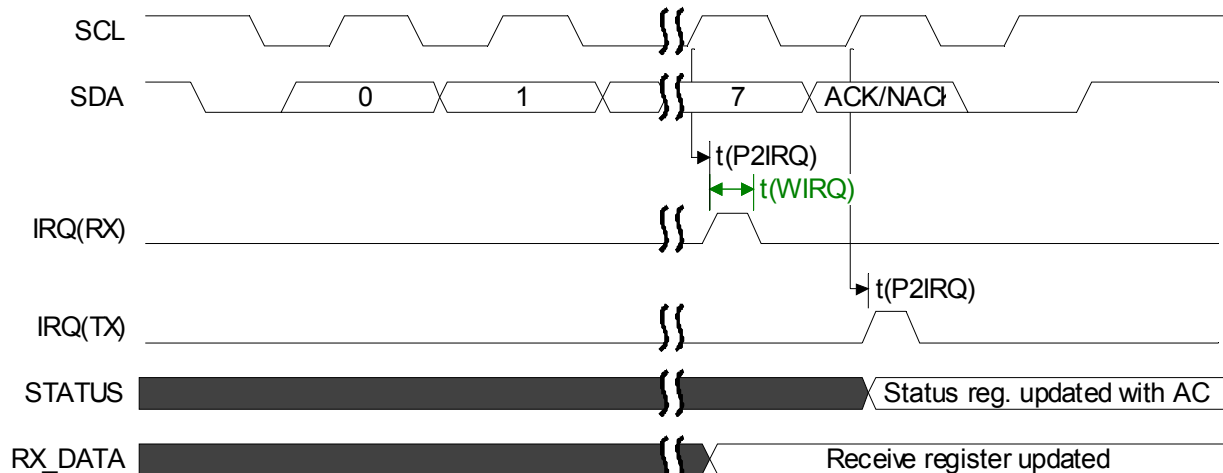

Figure 68. Interrupt request timing towards MCU

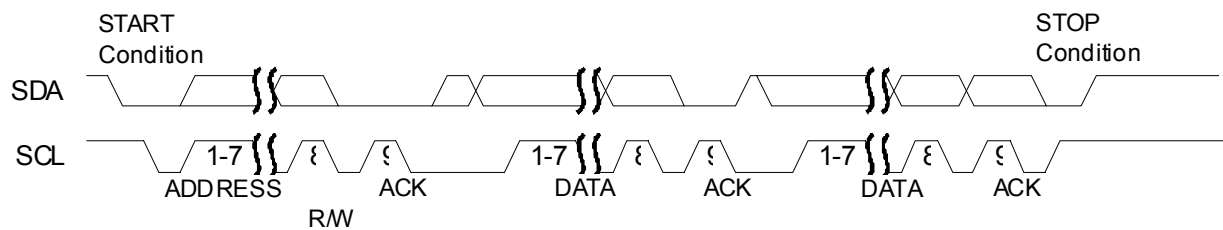

Figure 69. Complete data transfer

20.3 SFR registers

The following registers control the 2-Wire:

Address (Hex)	Name/Mnemonic	Bit	Reset value	Type	Description
0xE2	W2CON0	7:0	0x80	R/W	2-Wire configuration register 0.
	<i>broadcastEnable</i>	7	1	R/W	Slave only: 1: Respond to the general call address (0x00), as well as the address defined in WIRE2ADR. 0: Respond only to the address defined in WIRE2ADR.

Address (Hex)	Name/Mnemonic	Bit	Reset value	Type	Description
	<i>clockStop</i>	6	0	R/W	<p>Slave only:</p> <p>1: SCL is kept 'low' by the slave between byte transfers. This buys the MCU time to read RX data or write TX data. In TX mode SCL is released t_{REL} after TX data has been written to W2DAT. $t_{REL} = 1400$ ns in Standard and Fast modes, while $t_{REL} = 5 \cdot T_{ckCPU}$ in High-speed mode. In RX mode SCL is released immediately after the RX data is read from W2DAT.</p> <p>Note: Update this bit before any transmissions begin.</p> <p>0: The 2-Wire Slave does not alter the clock.</p>
	<i>xStop</i>	5	0	R/W	<p>Master only:</p> <p>1: Transmit stop condition 1) in RX mode: After the ongoing byte reception is completed; or 2) in TX mode: After any pending TX data is transmitted.</p> <p>Note: Do not attempt to clear a stop bit by writing a 0 to it.</p> <p>0: No stop condition to be sent. Cleared when the stop condition is transmitted.</p> <p>Slave only:</p> <p>1: Disable interrupt when stop condition is detected.</p> <p>0: Enable interrupt when stop condition is detected.</p>
	<i>xStart</i>	4	0	R/W	<p>Master only:</p> <p>1: Transmit start (repeated start) condition after any pending TX data or stop condition.</p> <p>Note: Do not attempt to clear a start bit by writing a 0 to it.</p> <p>0: No start (repeated start) condition to be sent. Cleared when the start (repeated start) condition is transmitted.</p> <p>Slave only:</p> <p>1: Disable interrupt on address match.</p> <p>0: Enable interrupt on address match.</p>
	<i>clockFrequency</i>	3:2	00	R/W	<p>Frequency on SCL.</p> <p>00: Idle.</p> <p>01: 100 kHz (Standard mode). Requires a system clock frequency of at least 4 MHz.</p> <p>10: 400 kHz (Fast mode). Requires a system clock frequency of at least 8 MHz.</p> <p>11: reserved.</p>
	<i>masterSelect</i>	1	0	R/W	<p>1: Master mode selected.</p> <p>0: Slave mode selected.</p>

Address (Hex)	Name/Mnemonic	Bit	Reset value	Type	Description
	<i>wire2Enable</i>	0	0	R/W	1: 2-Wire is enabled. The clock to the 2-Wire core functionality is running. An 2-Wire transfer can be initiated by the MCU via the 8051 SFR Bus (TX). Note: This bit must be set in a separate write operation before any other 2-Wire configuration bits are written. 0: 2-Wire is disabled. The clock to the 2-Wire core functionality stands still.
0xE1	W2CON1	5:0	0x00	R/W	2-Wire configuration register 1/status register.
	<i>maskIrq</i>	5	0	R/W	1: Disable all interrupts. 0: Enable all interrupts (not masked otherwise). Note: Update this bit before any transmissions begin.
	<i>broadcast</i>	4		R	Slave only: 1: The last received address was a broadcast address (0x00). 0: The last received address was not a broadcast address. Cleared when reading W2CON1.
	<i>stop</i>	3		R	Slave only: 1: Interrupt caused by stop condition. 0: No interrupt caused by stop condition. Cleared when reading W2CON1.
	<i>addressMatch</i>	2		R	Slave only: 1: Interrupt caused by address match. 0: No interrupt caused by address match. Cleared when reading W2CON1.
	<i>ack_n</i>	1		R	TX mode only: 1: Not-acknowledge (NACK). 0: Acknowledge (ACK). This bit contains the acknowledge 2-Wire has received after the last transfer. Cleared when reading W2CON1.
	<i>dataReady</i>	0		R	1: Interrupt caused by byte transmitted/received. 0: No interrupt caused by byte transmitted/received. Cleared when reading W2CON1.
0xD9	W2SADR	6:0	0x00	R/W	2-Wire Slave address register. The address the 2-Wire reacts upon in slave mode.
0xDA	W2DAT	7:0	0x00	R/W	2-Wire data register. Accesses TX (write) and RX (read) buffers, both one byte deep.

Table 99. Wire registers

The 2-Wire is enabled by setting W2CON0[0] to '1'. W2CON0[1] decides whether it shall act as Master or Slave. The baudrate is defined by W2CON0[3:2].

Note: The 2-Wire needs a system clock frequency of at least 4 MHz to function correctly in Standard mode. In Fast mode, the system clock frequency must be at least 8 MHz.

21 ADC

nRF24LE1 includes a general purpose ADC with up to 14 input channels, depending on package variant. The ADC contains an internal 1.2V reference, but can also be used with external reference or full scale range equal to VDD. It can be operated in a single step mode with sampling under software control, or a continuous conversion mode with a programmable sampling rate.

21.1 Features

- 6, 8, 10 or 12 bit resolution
- Up to 14 input channels
- Single ended or differential input
- Full-scale range set by internal reference, external reference or VDD
- Single step mode with conversion time down to 3 μ s
- Continuous mode with 2, 4, 8 or 16 kbps sampling rate
- Low current consumption; only 0.1 mA at 2 kbps
- Mode for measuring supply voltage

21.2 Block diagram

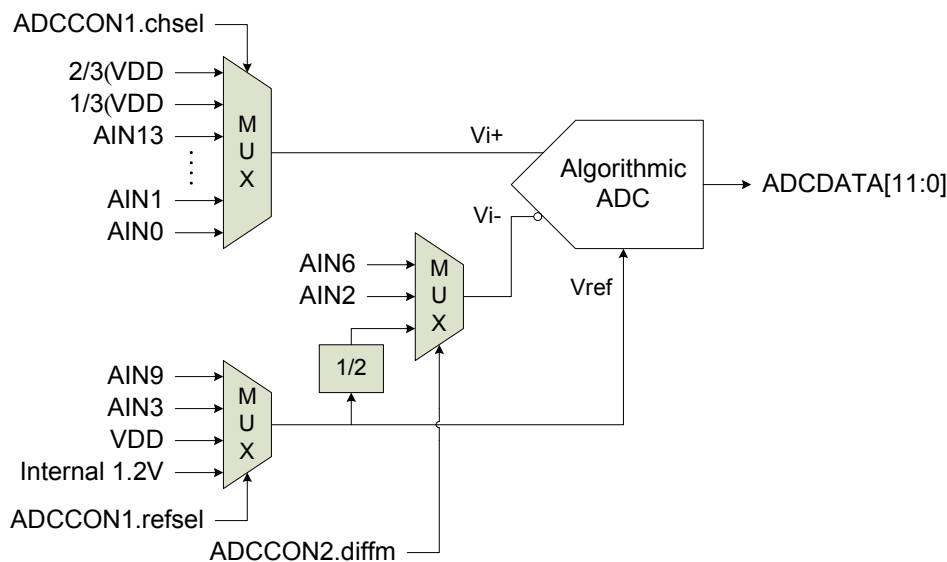

Figure 70. Block diagram of ADC

21.3 Functional description

21.3.1 Activation

A write operation to the ADCCON1 register automatically starts a conversion, provided that the `pwrup` bit is set. If the ADC is busy, the unfinished conversion is aborted and a new one initiated. Write operations to ADCCON2 and ADCCON3 do not start a conversion. It is not advisable to change these registers while the ADC is busy.

21.3.2 Input selection

The ADC supports up to 14 external and 2 internal input channels, and can be configured for single ended or differential measurements. Input channel is selected with the `chsel` bits. Channel 0 to 13 (AIN0-AIN13) are external inputs applied through port pins. Channel 14 and 15 are internally generated inputs equal to $1/3 \cdot V_{DD}$ and $2/3 \cdot V_{DD}$, respectively. The number of available external inputs depends on package variant. See [chapter 17 on page 132](#) for a description of the mapping between port pins and AIN0-AIN13.

Configure `diffm` to select between single ended and differential mode. In single ended mode the input range is from 0V up to the reference voltage V_{REF} , in differential mode from $-V_{REF}/2$ to $+V_{REF}/2$. Either AIN2 or AIN6 can be used as inverting input in differential mode. Non-inverting input is selected with `chsel`. The common-mode voltage must be between 25% and 75% of VDD.

The internally generated $1/3 V_{DD}$ and $2/3 V_{DD}$ inputs may be used for supply voltage measurement or calibration of offset and gain error.

21.3.3 Reference selection

Full-scale range is controlled by the `refsel` bits. It can be set by an internal bandgap reference (nominally 1.2V), external reference or VDD. The external reference voltage is applied on AIN3 or AIN9, and must be between 1.15V and 1.5V. It is buffered by an on-chip CMOS buffer with very high input impedance.

21.3.4 Resolution

The ADC can do 6, 8, 10 or 12 bit conversions. Configure the `resol` bits to set resolution.

21.3.5 Conversion modes

The `cont` bit selects between single step and continuous conversion mode. In single step mode the ADC performs one conversion and then stops. In continuous mode it runs continuously with a programmable sampling rate.

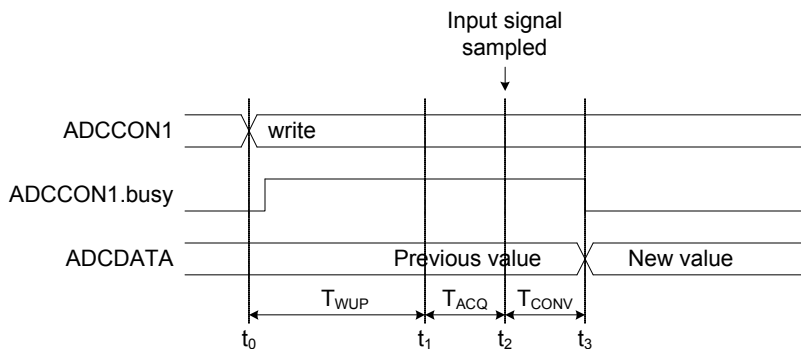

Figure 71. Timing diagram for single step conversion

[Figure 71.](#) illustrates the timing of a single step conversion. The conversion is started by writing to the ADCCON1 register. The busy bit is set to '1' four 16 MHz clock cycles afterwards and cleared again when the conversion result becomes available in the ADCDATA/ADCDATL registers. An interrupt to the MCU (ADCIRQ) is also generated at the end of conversion.

By default the ADC is powered down immediately after end of conversion. It can also be configured to enter standby mode after end of conversion, and proceed to a full power-down after a programmable delay. This shortens the wakeup time if a new conversion is initiated before the power-down delay has elapsed. Configure the `rate` bits to choose behavior. Note that this automatic power-down will not clear the `pwrup` bit, and the selected port pin(s) will continue to be configured as analog input(s) until the `pwrup` bit is cleared from software.

A conversion can be divided into three phases: wakeup, signal acquisition and conversion. The wakeup time depends on whether the ADC was powered down or in standby mode before initiation. If it was powered down it needs $T_{WUP} = 15\mu s$ to wake up. Otherwise, $T_{WUP} = 0.6\mu s$.

The sampling capacitor is switched to the analog input at the end of the wakeup phase (at $t = t_1$) and remains connected throughout the acquisition phase. The sample is acquired at the end of the acquisition phase (at $t = t_2$). The duration of this phase is $T_{ACQ} = 0.75, 3, 12$ or $36\mu s$, selected with the `tacq` bits.

The final phase is the time used by the ADC to convert the analog sample into a N-bit digital representation. This time depends on the selected resolution: $T_{CONV} = 1.7, 1.9, 2.1$ and $2.3\mu s$ for 6, 8, 10 and 12-bit conversions, respectively. [Table 100](#), shows the total conversion time for all combinations of acquisition time and resolution.

T _{ACQ}	Starting from standby mode				Starting from power-down				Unit
	6-bit	8-bit	10-bit	12-bit	6-bit	8-bit	10-bit	12-bit	
0.75	3.0	3.2	3.4	3.6	17.4	17.6	17.8	18.0	μs
3	5.3	5.4	5.6	5.8	19.7	19.9	20.1	20.3	μs
12	14.3	14.4	14.6	14.8	28.7	28.9	29.1	29.3	μs
36	38.3	38.4	38.6	38.8	52.7	52.9	53.1	53.3	μs

Table 100. Single step conversion time

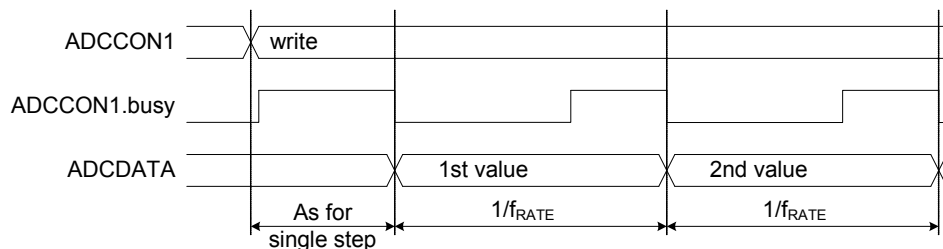

Figure 72. Timing diagram for continuous conversion

Continuous conversion mode operates exactly like single step, except that new conversions are started automatically at a programmable rate. The converter enters power down mode between conversions to minimize current consumption. Sampling rate is specified with the `rate` bits, and can be 2, 4, 8 or 16 ksp/s.

21.3.6 Output data coding

The ADC uses straight binary coding for single ended conversions. An input voltage $\leq 0V$ is represented by all zeroes (000...00), and an input voltage $\geq V_{REF}$ by all ones (111...11). Midscale is represented by a one followed by all zeroes (100...00).

Differential conversions use offset binary coding. A differential input voltage $\leq -V_{REF}/2$ is represented by all zeroes (000...00), and an input voltage $\geq +V_{REF}/2$ by all ones (111...11). Zero-scale is represented by a one followed by all zeroes (100...00).

The ADCCON3 register contains 3 overflow bits; `uflow` is set when the ADC is under ranged, `oflow` is set when the ADC is over ranged, while `range` is the logical OR of `uflow` and `oflow`.

21.3.7 Driving the analog input

The analog input pin draws a small current transient each time the internal sampling capacitor is switched to the input at the beginning of the acquisition phase. It is important that the circuitry driving the input settles from this disturbance before the conversion is started. Unless the input is driven by a sufficiently fast op-amp, it may be necessary to choose a longer than minimum acquisition time to ensure proper settling. But note that this extends the conversion time accordingly, and hence the time delay before the ADC returns to power-down mode. If current consumption is important, the acquisition time should be made as short as possible.

[Figure 73](#) gives recommendations for acquisition time as a function of source resistance and capacitance, assuming a passive signal source and 10-bit conversions. If for instance the source resistance is 100kΩ and the off-chip capacitance on the analog input pin is 10pF, it can be read out from the figure that the recommended acquisition time is 12μs.

Alternatively, a large capacitor may be connected between the analog input pin and VSS. It will supply all the current to the sampling capacitor, so that minimum acquisition time can be used even if the source resistance is high. A capacitor value of 33nF or higher is recommended.

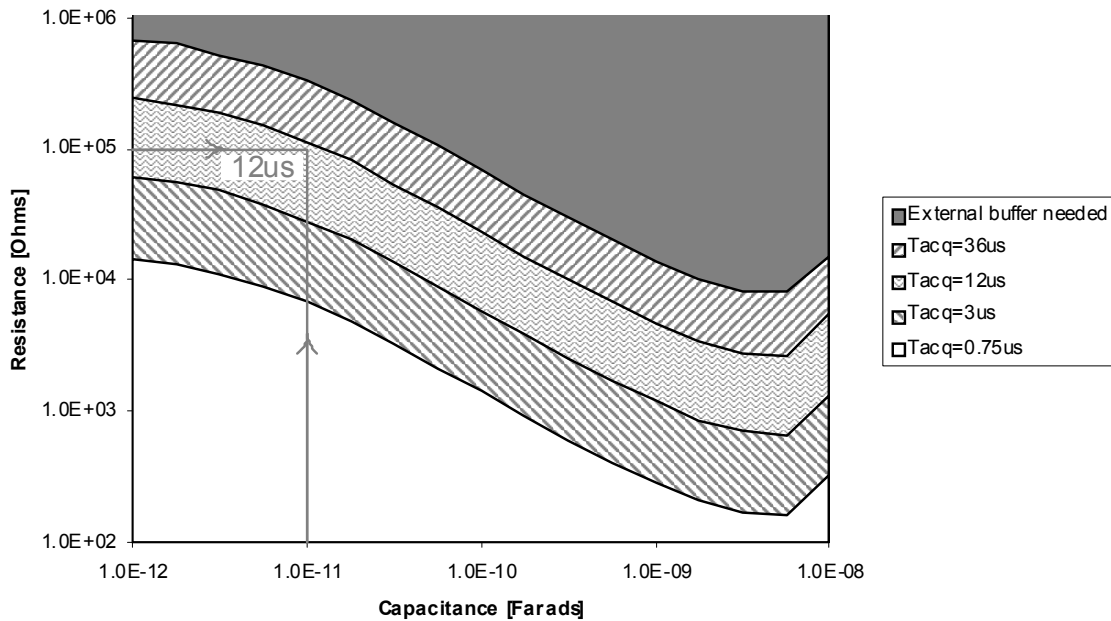

Figure 73. Recommended acquisition time versus source resistance and capacitance (10-bit conversions)

21.3.8 SFR registers

The ADC is interfaced to the MCU through five registers; ADCCON1, ADCCON2, ADCCON3, ADCDATH and ADCDATL. ADCCON1, ADCCON2 and ADCCON3 contain configuration settings and status bits. The conversion result is contained in the ADCDATH and ADCDATL registers.

Addr	Bit	Name	RW	Function	Reset value: 0x00
0xD3	7	pwrup	RW	Power-up control: 0: Power down ADC 1: Power up ADC and configure selected pin(s) as analog input	
	6	busy	R	ADC busy flag: 0: No conversion in progress 1: Conversion in progress The <i>busy</i> bit is cleared when a conversion result becomes available in the ADCDATH / ADCDATL registers.	
	5:2	chsel	RW	Input channel select: 0000: AIN0 0001: AIN1 : 1101: AIN13 1110: 1/3-VDD 1111: 2/3-VDD	
	1:0	refsel	RW	Reference select: 00: Internal 1.2V reference 01: VDD 10: External reference on AIN3 11: External reference on AIN9	

Table 101. ADCCON1 register

Addr	Bit	Name	RW	Function	Reset value: 0x00
0xD2	7:6	diffm	RW	Selects single ended or differential mode: 00: Single ended 01: Differential with AIN2 as inverting input 10: Differential with AIN6 as inverting input 11: Not used	
	5	cont	RW	Selects single step or continuous conversion mode: 0: Single step conversion 1: Continuous conversion with sampling rate defined by rate	
	4:2	rate	RW	Selects sampling rate in continuous conversion mode: 000: 2 ksps 001: 4 ksps 010: 8 ksps 011: 16 ksps 1XX: Reserved Selects power-down delay in single-step mode: 000: 0µs 001: 6µs 010: 24µs 011: Infinite (clear pwrup to power down) 1XX: Reserved	

Addr	Bit	Name	RW	Function	Reset value: 0x00
	1:0	tacq	RW	Duration of input acquisition window (T_{ACQ}): 00: 0.75 μ s 01: 3 μ s 10: 12 μ s 11: 36 μ s	

Table 102. ADCCON2 register

Addr	Bit	Name	RW	Function	Reset value: 0x00
0xD1	7:6	resol	RW	ADC resolution: 00: 6 bits 01: 8 bits 10: 10 bits 11: 12 bits	
	5	rljust	RW	Selects left or right justified data in ADCDATH / ADCDATL: 0: Left justified data 1: Right justified data	
	4	uflow	R	ADC underflow when set (conversion result is all zeroes)	
	3	oflow	R	ADC overflow when set (conversion result is all ones)	
	2	range	R	ADC overflow or underflow when set (equals oflow OR uflow)	
	1:0	-	-	Not used	

Table 103. ADCCON3 register

Addr	Bit	Name	RW	Function	Reset value: 0x00
0xD4	7:0	-	R	Most significant byte of left or right justified ADCDATA (see Table 106.)	

Table 104. ADCDATH register

Addr	Bit	Name	RW	Function	Reset value: 0x00
0xD5	7:0	-	R	Least significant byte of left or right justified ADCDATA (see Table 106.)	

Table 105. ADCDATL register

rljust	resol	ADCDATH[7:0]	ADCDATL[7:0]
0	00	ADCDATA[5:0]	0
0	01	ADCDATA[7:0]	0
0	10	ADCDATA[9:0]	0
0	11	ADCDATA[11:0]	0
1	00	0	ADCDATA[5:0]
1	01	0	ADCDATA[7:0]
1	10	0	ADCDATA[9:0]
1	11	0	ADCDATA[11:0]

Table 106. Left or right justified output data

22 Analog comparator

The analog comparator is used as a wakeup source. It allows a system wakeup to be triggered by the voltage level of a differential or single ended analog input applied through the port pins. The comparator has very low current consumption, and is operational in the register retention mode and memory retention mode timer on.

22.1 Features

- Low current consumption (0.75µA typical)
- Differential or single-ended input
- Single-ended threshold programmable to 25%, 50%, 75% or 100% of VDD or an arbitrary reference voltage from pin
- 14-channel input multiplexer
- Rail-to-rail input voltage range
- Programmable output polarity

22.2 Block diagram

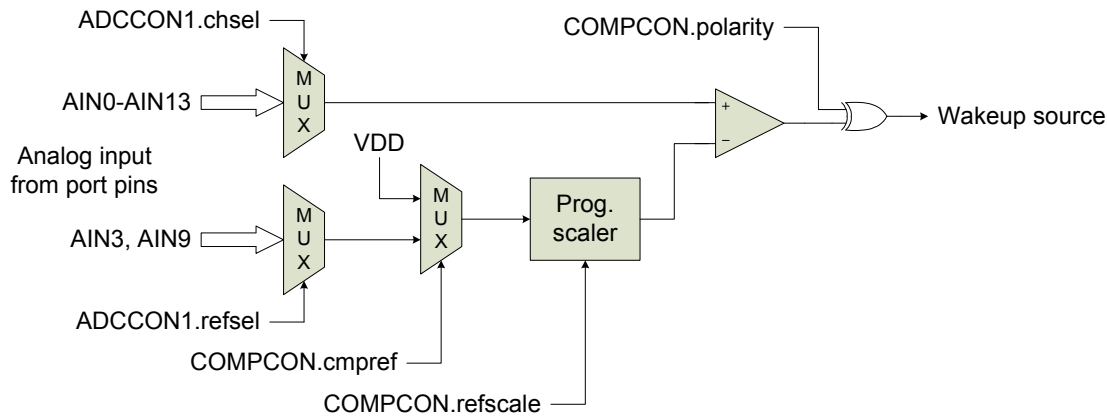

Figure 74. Block diagram of analog comparator

22.3 Functional description

22.3.1 Activation

Enable the comparator by setting the `enable` bit in the `COMPCON` register. The comparator is activated when the system enters register retention mode or memory retention mode timer on. It is not operational in any other system modes. In order to use the comparator a 32 kHz clock source must also be activated.

22.3.2 Input selection

Depending on package variant, one out of up to 14 different port pins may be used to apply a voltage to the non-inverting comparator input. Configure the `chsel` bits in the `ADCCON1` register to select one of AIN0 through AIN13 as input. Note that '1110' and '1111' are illegal values; if these are specified the non-inverting comparator input will float. The `pwrap` bit in `ADCCON1` does not have to be set.

Refer to [chapter 17 on page 132](#) for a description of the mapping between port pins and AIN0-AIN13.

22.3.3 Reference selection

The inverting comparator input can be connected to 25%, 50%, 75% or 100% of either VDD or an arbitrary reference voltage from AIN3 or AIN9. Configure the `refscale` bits in `COMPCON` to select scaling factor. To use VDD as a reference, set `cmpref` to '0'. To use an arbitrary reference, set `cmpref` to '1' and configure `refsel` in `ADCCON1` to choose between AIN3 and AIN9 as input pin for the reference. Note that '00' and '01' are illegal values for `refsel`; if these are specified the inverting comparator input will float.

Differential input mode is configured by setting `refscale` to 100% and choosing AIN3 or AIN9 as inverting input.

22.3.4 Output polarity

The polarity of the comparator output is programmable. The default behavior is that a wakeup is triggered when the non-inverting input rises above the inverting input. However, if the `polarity` bit is set a wakeup is triggered when the non-inverting input drops below the inverting input.

22.3.5 Input voltage range

The input voltage range on AIN0-AIN13 is from VSS to VDD+100mV. However, the input voltage must never exceed 3.6V.

22.3.6 Configuration examples

Wakeup criterion	ADCCON1		COMPCON		
	chsel	refsel	polarity	refscale	cmpref
AIN0 > 0.25·VDD	0000	XX	0	00	0
AIN13 < 0.5·VDD	1101	XX	1	01	0
AIN2 > 0.75·AIN3	0010	10	0	10	1
AIN3 < AIN9	0011	11	1	11	1

Table 107. Configuration examples

22.3.7 Driving the analog input

The comparator has a switched capacitor input clocked at 32 kHz. It is recommended to connect a 330pF bypass capacitor between the analog input pin(s) and VSS. This reduces voltage transients introduced by the switching. The capacitor may be omitted if the signal source has an output resistance smaller than 100kΩ. The input bias current of the comparator is typically below 100nA.

22.3.8 SFR registers

The comparator is interfaced through two registers. ADCCON1 configures the multiplexing of external inputs. Other functions are controlled by the COMPCON register.

Addr	Bit	Name	RW	Function	Reset value: 0x00
0xDB	7:5	-	-	Not used	
	4	polarity	RW	Output polarity: 0: Non-inverting 1: Inverting	
	3:2	refscale	RW	Reference voltage scaling: 00: 25% 01: 50% 10: 75% 11: 100%	
	1	cmpref	RW	Reference select: 0: VDD 1: External reference on AIN3 or AIN9	
	0	enable	RW	Enable/disable comparator: 0: Disable comparator 1: Enable comparator and configure selected pin(s) as analog input	

Table 108. COMPCON register

23 PWM

The nRF24LE1 includes a two channel Pulse-Width Modulation (PWM) module. The two channels (PWM0 and PWM1) share a common programmable frequency and resolution register and have an individually controlled duty cycle, as described in [section 23.3](#) and each channel is available at output port pins PWM0 and PWM1.

23.1 Features

- Two-channel output
- Frequency-range from 4 kHz to 254 kHz (when MCU is clocked at 16 MHz)
- Compact control using few registers for enabling, length-setting and prescaler

23.2 Block diagram

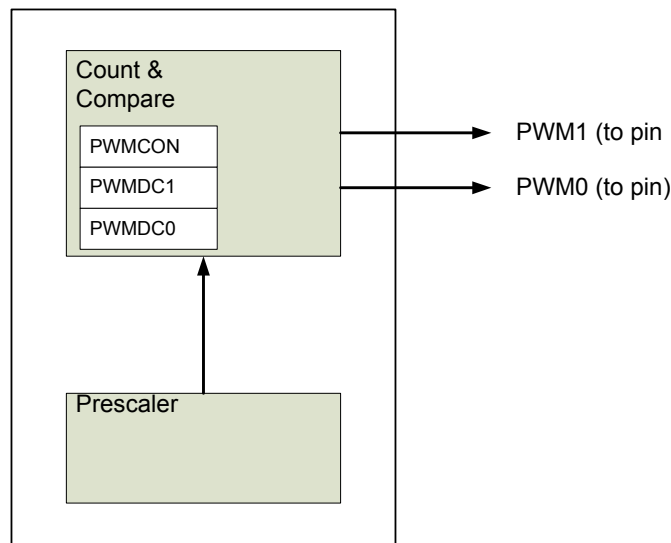

Figure 75. Block diagram of PWM

23.3 Functional description

The nRF24LE1 PWM is a two-channel PWM with a three register interface. The first register, `PWMCON`, enables the PWM function and sets the PWM period length, which is the number of clock cycles for one PWM period, as shown in [Table 109](#). The registers, `PWMDC0` and `PWMDC1`, control the duty cycle for each PWM channel. When one of these registers is written, the corresponding PWM signal changes immediately to the new value. This can result in four transitions within one PWM period, but the transition period will always have a “DC value” between the old sample and the new sample.

The following table shows how the PWM frequency (or period length) and the PWM duty cycle are controlled by the PWM SFR registers. PWM frequency range is approximately 4 kHz-254 kHz.

PWMCON 7:6 (Number of bits)	PWM frequency	PWM duty cycle
00 (5)	$Cclk \cdot \frac{1}{31(PWMCON[5:2]+1)}$	$\frac{PWMDC[4:0]}{31}$
01 (6)	$Cclk \cdot \frac{1}{63(PWMCON[5:2]+1)}$	$\frac{PWMDC[5:0]}{63}$
10 (7)	$Cclk \cdot \frac{1}{127(PWMCON[5:2]+1)}$	$\frac{PWMDC[6:0]}{127}$
11 (8)	$Cclk \cdot \frac{1}{255(PWMCON[5:2]+1)}$	$\frac{PWMDC}{255}$

Table 109. PWM frequency and duty-cycle setting

The PWM is controlled by SFR 0xB2, 0xA1 and 0xA2.

Addr SFR (HEX)	R/W	#bit	Reset (HEX)	Name	Function
0xB2	R/W	8	0	PWMCON	PWM control register 7-6: Enable / period length select 00: Period length is 5 bit 01: Period length is 6 bit 10: Period length is 7 bit 11: Period length is 8 bit 5-2: PWM frequency pre-scale factor (see table above) 1: Select output port pin for pwm1: 0: pwm1 disabled 1: pwm1 enabled and available on port 0: Select output port pin for pwm0: 0: pwm0 disabled 1: pwm0 enabled and available on port
0xA1	R/W	8	0	PWMDC0	PWM duty cycle for channel 0 (5 to 8 bits according to period length)
0xA2	R/W	8	0	PWMDC1	PWM duty cycle for channel 1 (5 to 8 bits according to period length)

Table 110. PWM control registers

24 Absolute maximum ratings

Maximum ratings are the extreme limits to which the nRF24LE1 can be exposed without permanently damaging it. Exposure to absolute maximum ratings for prolonged periods of time may affect device reliability.

The device is not guaranteed to operate properly at the maximum ratings.

Operating conditions	Minimum	Maximum	Units
Supply voltages			
VDD	-0.3	+3.6	V
VSS		0	V
I/O pin voltage			
V_{IO}	-0.3	VDD +0.3, max 3.6	V
Temperatures			
Operating temperature	-40	+85	°C
Storage temperature	-40	+125	°C

Table 111. Absolute maximum ratings

Note: Stress exceeding one or more of the limiting values may cause permanent damage to the device.

<p>Attention! Observe precaution for handling Electrostatic Sensitive Device.</p> <p>HBM (Human Body Model): Class 2</p>	
---	---

25 Operating condition

Symbol	Parameter	Notes	Min.	Typ.	Max.	Units
VDD	Supply voltage		1.9	3.0	3.6	V
t _{R_VDD}	Supply rise time (0V to 1.9V)	a	1μs		50ms	μs and ms
T _A	Operating temperature		-40		+85	°C

- a. The on-chip power-on reset circuitry may not function properly for rise times outside the specified interval.

Table 112. Operating conditions

26 Electrical specifications

This section contains electrical and timing specifications.

Conditions: VDD = 3.0V, T_A = -40°C to +85°C (unless otherwise noted)

Symbol	Parameter (condition)	Notes	Min.	Typ.	Max.	Units
V _{IH}	Input high voltage		0.7·VDD		VDD	V
V _{IL}	Input low voltage		VSS		0.3·VDD	V
V _{OH}	Output high voltage (std. drive, 0.5 mA)		VDD-0.3		VDD	V
V _{OH}	Output high voltage (high-drive, 5 mA)	a	VDD-0.3		VDD	V
V _{OL}	Output low voltage (std. drive, 0.5 mA)		VSS		0.3	V
V _{OL}	Output low voltage (high-drive, 5 mA)	a	VSS		0.3	V
R _{PU}	Pull-up resistance		11	13	16	kΩ
R _{PD}	Pull-down resistance		11	13	16	kΩ

a. Maximum number of pins with 5mA high drive is 3.

Table 113. Digital inputs/outputs

Symbol	Parameter (condition)	Notes	Min.	Typ.	Max.	Units
General RF conditions						
f _{OP}	Operating frequency	a	2400		2525	MHz
PLL _{res}	PLL Programming resolution			1		MHz
f _{X TAL}	Crystal frequency			16		MHz
Δf ₂₅₀	Frequency deviation @ 250 kbps			±160		kHz
Δf _{1M}	Frequency deviation @ 1 Mbps			±160		kHz
Δf _{2M}	Frequency deviation @ 2 Mbps			±320		kHz
R _{GFSK}	Air data rate	b	250		2000	kbps
F _{CHANNEL 1M}	Non-overlapping channel spacing @ 250 kbps/1 Mbps)	c		1		MHz
F _{CHANNEL 2M}	Non-overlapping channel spacing @ 2 Mbps			2		MHz
Transmitter operation						
P _{RF}	Maximum output power	d		0	+4	dBm
P _{RFC}	RF power control range		16	18	20	dB
P _{RFCR}	RF power accuracy				±4	dB
P _{BW2}	20dB bandwidth for modulated carrier (2 Mbps)			1800	2000	kHz
P _{BW1}	20dB bandwidth for modulated carrier (1 Mbps)			950	1100	kHz
P _{BW250}	20dB bandwidth for modulated carrier (250 kbps)			700	800	kHz
P _{RF1.2}	1 st Adjacent Channel Transmit Power 2 MHz (2 Mbps)				-20	dBc
P _{RF2.2}	2 nd Adjacent Channel Transmit Power 4 MHz (2 Mbps)				-45	dBc
P _{RF1.1}	1 st Adjacent Channel Transmit Power 1 MHz (1 Mbps)				-20	dBc

Symbol	Parameter (condition)	Notes	Min.	Typ.	Max.	Units
$P_{RF2.1}$	2 nd Adjacent Channel Transmit Power 2 MHz (1Mbps)				-40	dBc
$P_{RF1.250}$	1 st Adjacent Channel Transmit Power 1 MHz (250 kbps)				-25	dBc
$P_{RF2.250}$	2 nd Adjacent Channel Transmit Power 2 MHz (250 kbps)				-40	dBc
Receiver operation						
RX_{MAX}	Maximum received signal at < 0.1% BER			0		dBm
RX_{SENS}	Sensitivity (0.1% BER) @ 2 Mbps			-82		dBm
RX_{SENS}	Sensitivity (0.1% BER) @ 1 Mbps			-85		dBm
RX_{SENS}	Sensitivity (0.1% BER) @ 250 kbps	e		-94		dBm
RX selectivity according to ETSI EN 300 440-1 V1.3.1 (2001-09) page 27						
C/I_{CO}	C/I co-channel (2 Mbps)			7		dBc
C/I_{1ST}	1 st ACS (Adjacent Channel Selectivity), C/I 2 MHz (2 Mbps)			3		dBc
C/I_{2ND}	2 nd ACS, C/I 4 MHz (2 Mbps)			-17		dBc
C/I_{3RD}	3 rd ACS, C/I 6 MHz (2 Mbps)			-21		dBc
C/I_{Nth}	N th ACS, C/I $f_i > 12$ MHz (2 Mbps)	f		-40		dBc
C/I_{Nth}	N th ACS, C/I $f_i > 36$ MHz (2 Mbps)			-48		dBc
C/I_{CO}	C/I co-channel (1 Mbps)			9		dBc
C/I_{1ST}	1 st ACS, C/I 1 MHz (1 Mbps)			8		dBc
C/I_{2ND}	2 nd ACS, C/I 2 MHz (1 Mbps)			-20		dBc
C/I_{3RD}	3 rd ACS, C/I 3 MHz (1 Mbps)			-30		dBc
C/I_{Nth}	N th ACS, C/I $f_i > 6$ MHz (1 Mbps)			-40		dBc
C/I_{Nth}	N th ACS, C/I $f_i > 25$ MHz (1 Mbps)	f		-47		dBc
C/I_{CO}	C/I co-channel (250 kbps)			12		dBc
C/I_{1ST}	1 st ACS, C/I 1 MHz (250 kbps)			-12		dBc
C/I_{2ND}	2 nd ACS, C/I 2 MHz (250 kbps)			-33		dBc
C/I_{3RD}	3 rd ACS, C/I 3 MHz (250 kbps)			-38		dBc
C/I_{Nth}	N th ACS, C/I $f_i > 6$ MHz (250 kbps)			-50		dBc
C/I_{Nth}	N th ACS, C/I $f_i > 25$ MHz (250 kbps)	f		-60		dBc
RX selectivity with nRF24L01 equal modulation on interfering signal (Pin = -67dBm for wanted signal)						
C/I_{CO}	C/I co-channel (2 Mbps) (modulated carrier)			11		dBc
C/I_{1ST}	1 st ACS (Adjacent Channel Selectivity), C/I 2 MHz (2 Mbps)			4		dBc
C/I_{2ND}	2 nd ACS, C/I 4 MHz (2 Mbps)			-18		dBc
C/I_{3RD}	3 rd ACS, C/I 6 MHz (2 Mbps)			-24		dBc
C/I_{Nth}	N th ACS, C/I $f_i > 12$ MHz (2 Mbps)			-40		dBc
C/I_{Nth}	N th ACS, C/I $f_i > 36$ MHz (2 Mbps)			-48		dBc
C/I_{CO}	C/I co-channel (1 Mbps)			12		dBc
C/I_{1ST}	1 st ACS, C/I 1 MHz (1 Mbps)			8		dBc

Symbol	Parameter (condition)	Notes	Min.	Typ.	Max.	Units
C/I _{2ND}	2 nd ACS, C/I 2 MHz (1 Mbps)			-21		dBc
C/I _{3RD}	3 rd ACS, C/I 3 MHz (1 Mbps)			-30		dBc
C/I _{Nth}	N th ACS, C/I f _i > 6 MHz (1 Mbps)			-40		dBc
C/I _{Nth}	N th ACS, C/I f _i > 25 MHz (1 Mbps)			-50		dBc
C/I _{CO}	C/I co-channel (250 kbps)			7		dBc
C/I _{1ST}	1 st ACS, C/I 1 MHz (250 kbps)			-12		dBc
C/I _{2ND}	2 nd ACS, C/I 2 MHz (250 kbps)			-34		dBc
C/I _{3RD}	3 rd ACS, C/I 3 MHz (250 kbps)			-39		dBc
C/I _{Nth}	N th ACS, C/I f _i > 6 MHz (250 kbps)			-50		dBc
C/I _{Nth}	N th ACS, C/I f _i > 25 MHz (250 kbps)			-60		dBc
RX intermodulation performance in line with Bluetooth specification version 2.0, 4th November 2004, page 42						
P_IM(6) @ 2Mbps	Input power of IM interferers at 6 and 12 MHz distance from wanted signal	g		-42		dBm
P_IM(8) @ 2Mbps	Input power of IM interferers at 8 and 16 MHz distance from wanted signal	g		-38		dBm
P_IM(10) @ 2Mbps	Input power of IM interferers at 10 and 20 MHz distance from wanted signal	g		-37		dBm
P_IM(3) @ 1Mbps	Input power of IM interferers at 3 and 6 MHz distance from wanted signal	g		-36		dBm
P_IM(4) @ 1Mbps	Input power of IM interferers at 4 and 8 MHz distance from wanted signal	g		-36		dBm
P_IM(5) @ 1Mbps	Input power of IM interferers at 5 and 10 MHz distance from wanted signal	g		-36		dBm
P_IM(3) @ 250kbps	Input power of IM interferers at 3 and 6 MHz distance from wanted signal	g		-36		dBm
P_IM(4) @ 250kbps	Input power of IM interferers at 4 and 8 MHz distance from wanted signal	g		-36		dBm
P_IM(5) @ 250kbps	Input power of IM interferers at 5 and 10 MHz distance from wanted signal	g		-36		dBm
ADC h						
DNL	Differential nonlinearity.	i j		0.5		LSB
INL	Integral nonlinearity.	i k		0.75		LSB
V _{OS}	Offset error.	i l		1.3		% FS
ε _G	Gain error.	i m		-2.5		% FS
SINAD	Signal-to-noise and distortion ratio (f _{IN} = 1 kHz, f _S = 16 ksps).	i		57		dB
SFDR	Spurious free dynamic range (f _{IN} = 1 kHz, f _S = 16 ksps).	i		65		dB
V _{REF_INT}	Internal reference voltage			1.2		V
TC _{REF_INT}	Internal reference voltage drift			300		ppm/°C
V _{REF_EXT}	External reference voltage		1.15		1.5	V
Analog comparator						
V _{OS}	Input offset voltage	n	-50		+50	mV
Program memory and non-volatile data memory						
T _{PROG}	Byte write time				40	μs

Symbol	Parameter (condition)	Notes	Min.	Typ.	Max.	Units
N _{ENDUR}	Endurance		1000			cycles
T _{RET}	Data retention (T _A = +25°C)		100			years
Extended endurance non-volatile data memory						
T _{PROG_EXT}	Byte write time				100	µs
N _{ENDUR}	Endurance		20000			cycles
T _{RET}	Data retention (T _A = +25°C)		5			years
16 MHz crystal						
f _{NOM}	Nominal frequency (parallel resonant)			16.000		MHz
f _{TOL}	Frequency tolerance	o p			±60	ppm
C _L	Load capacitance			12	16	pF
C ₀	Shunt capacitance			3	7	pF
ESR	Equivalent series resistance			50	100	Ω
P _D	Drive level				100	µW
L _S	Equivalent serial inductance	q		30		mH
32 kHz crystal						
f _{NOM}	Crystal frequency (parallel resonant)			32.768		kHz
C _L	Load capacitance			9	12.5	pF
C ₀	Shunt capacitance			1	2	pF
ESR	Equivalent series resistance			50	80	kΩ
P _D	Drive level				1	µW
16 MHz RC oscillator						
f _{NOM}	Nominal frequency			16		MHz
f _{TOL}	Frequency tolerance			±1	±5	%
32 kHz RC oscillator						
f _{NOM}	Nominal frequency			32.8		kHz
f _{TOL}	Frequency tolerance			±1	±10	%
Power-Fail Comparator						
V _{POF}	Nominal thresholds (falling supply voltage)		2.1, 2.3, 2.5, 2.7			V
V _{TOL}	Threshold voltage tolerance				±5	%
V _{HYST}	Threshold voltage hysteresis			100		mV

- Usable band is determined by local regulations.
- Data rate in each burst on-air.
- The minimum channel spacing is 1 MHz.
- Antenna load impedance = 15 Ω + j88 Ω.
- For 250 kbps sensitivity, frequencies which are integer multiples of 16 MHz (2400, 2416 and so on) sensitivity is reduced.
- Narrow Band (In Band) Blocking measurements:
0 to ±40 MHz; 1 MHz step size
For Interferer frequency offsets n*2*f_{xtal}, blocking performance is degraded by approximately 5 dB compared to adjacent figures.
- Wanted signal level at Pin = -64 dBm. Two interferers with equal input power are used. The interferer closest in frequency is unmodulated, the other interferer is modulated equal with the wanted signal. The input power of interferers where the sensitivity equals BER = 0.1% is presented.
- VDD is limited from 1.9V to 3.4V in the temperature range of -20°C to -30 °C and from 1.9V to 3.2V in the temperature range -30°C to -40°C.
- Measured with 10-bit resolution, single-ended input and VDD as reference.
- DNL given as (abs(DNL_{max}) + abs(DNL_{min}))/2
- INL given as (abs(INL_{max}) + abs(INL_{min}))/2

- l. Defined as the deviation of the first code transition (000...000) to (000...001) from the ideal.
- m. Defined as the deviation of the last code transition (111...110) to (111...111) from the ideal, after correcting for offset error.
- n. Measured with 100 k Ω source resistance and a 330pF bypass capacitor between the analog input and VSS.
- o. Includes initial accuracy, stability over temperature, aging and frequency pulling due to incorrect load capacitance.
- p. Frequency regulations in certain regions set tighter requirements on frequency tolerance (for example Japan and South Korea max ± 50 ppm).
- q. Startup time from power down to standby mode depends on the L_S parameter.

Table 114. Electrical specifications

26.1 Power consumption

The power consumption is always a sum of the current draw from all modules active at the time of measurement and is very application dependent.

To calculate a peak current draw summarize the currents from all modules that can be active at the same time in a given application.

Conditions: VDD = 3.0V, TA = +25°C

Symbol	Parameter (condition)	Notes	Min.	Typ.	Max.	Units
Core functions^a						
	Deep sleep mode			0.5		μA
	Memory retention mode, timers off			1.0		μA
	Memory retention mode, timers on (CLKLF from XOSC32K)			1.6		μA
	Memory retention mode, timers on (CLKLF from RCOSC32K)			1.8		μA
	Register retention mode, timers off			2.0		μA
	Register retention mode, timers on (CLKLF from XOSC32K)			3.0		μA
	Register retention mode, timers on (CLKLF from RCOSC32K)			3.2		μA
	Register retention mode, timers on (CLKLF from XOSC32K, XOSC16M running)			0.05		mA
	Register retention mode, timers on (CLKF synthesized from XOSC16M)			87		μA
	Standby mode (XOSC16M running)			1		mA
	Active mode (8 MHz MCU clock, 4 MIPS)			2.5		mA
Peripherals						
	Flash byte write			1.8		mA
	Flash page erase	b		1.0		mA
	Flash mass erase			0.8		mA
	RF transceiver in TX mode (P _{OUT} = 0 dBm)	c		11.1		mA
	RF transceiver in TX mode (P _{OUT} = -6 dBm)			8.8		mA
	RF transceiver in TX mode (P _{OUT} = -12 dBm)			7.3		mA
	RF transceiver in TX mode (P _{OUT} = -18 dBm)			6.8		mA
	RF transceiver in TX mode (P _{OUT} = -6 dBm)	d		0.12		mA
	Average current with ShockBurst™					

Symbol	Parameter (condition)	Notes	Min.	Typ.	Max.	Units
	RF transceiver during TX settling	e		7.8		mA
	RF transceiver in RX mode (2 Mbps)			13.3		mA
	RF transceiver in RX mode (1 Mbps)			12.9		mA
	RF transceiver in RX mode (250 kbps)			12.4		mA
	RF transceiver during RX settling	f		8.7		mA
	ADC when busy			1.5		mA
	ADC in standby mode			0.6		mA
	ADC in continuous mode @ 2 ksps (average current)	g		0.1		mA
	Random number generator			0.5		mA
	Analog comparator			0.8		µA

- a. Please note that all pins must be set to inputs, and that the pinMode input mode bits (refer to [Table 82. on page 142](#), [Table 83. on page 143](#), [Table 84. on page 144](#), and [Table 85. on page 145](#)) must be set to 2'b11 (Digital input buffer off) if the pins are not controlled externally.
- b. The processor is stalled during erase/write, so the actual consumption will go slightly down for these operations.
- c. Antenna load impedance = $15 \Omega + j88 \Omega$.
- d. Average data rate 10 kbps and full packets.
- e. Average current consumption for TX startup (130 µs), and when changing mode from RX to TX (130 µs).
- f. Average current consumption for RX startup (130 µs), and when changing mode from TX to RX (130 µs).
- g. 10-bit resolution, 0.75 µs acquisition time.

Table 115. Power consumption

27 HW debugger support

The nRF24LE1 has the following on-chip hardware debug support for a JTAG debugger:

- nRFProbe hardware debugger from Nordic Semiconductor.
- System Navigator from First Silicon Solutions (www.fs2.com).

These debug modules are available on device pins `OCITO`, `OCTMS`, `OCITDO`, `OCITDI`, `OCITCK` when enabled in the flash InfoPage. The HW debug features can be interfaced to a PC and utilized in the Keil Integrated Development Environment (IDE) by running nRFProbe found in the nRFgo development kits or dedicated HW from First Silicon Solutions.

27.1 Features

- Read/write all processor registers, SFR, program and data memory.
- Go/halt processor run control.
- Single step by assembly and C source instruction.
- Four independent HW execution breakpoints.
- Driver software for Keil μ Vision debugger interface.

The features listed below are for the Keil μ Vision debugger only:

- Load binary, Intel Hex or OMF51 file formats.
- Symbolic debug.
- Load symbols, including code, variables and variable types.
- Support C and assembly source code.
- Source window can display C source and mixed mode.
- Source window provides execution control; go, halt; goto cursor; step over/into call.
- Source window can set or clear software and hardware breakpoints.

27.2 Functional description

The JTAG debug interface is enabled by writing (through the flash SPI slave interface described in [section 6.3.5 on page 77](#)) to address 0x24 in the infopage. Any byte value other than 0xFF enables debug. The Flash Status Register (FSR bit 7, [Table 32. on page 76](#)) shows the current status of the interface.

The GPIO allocated in debug mode for each of the package alternatives is given in [section 17.3 on page 135](#), but summarized in [Table 116](#).

	24 pin 4×4	32 pin 5×5	48 pin 7×7
OCITO	P0.6	P1.3	P1.5
OCITDO	P0.5	P1.2	P1.4
OCITDI	P0.4	P1.1	P1.3
OCITMS	P0.3	P1.0	P1.2
OCITCK	P0.2	P0.7	P1.1

Table 116. HW debug physical interface for each nRF24LE1 package alternative

Note: A pull-up on `OCITCK` is required for the MCU to run (in debug mode) without the system navigator cable plugged in.

A separate "Trigger Out" is available on the `OCITO` pin. This output can be activated when certain address and data combinations occur.

28 Mechanical specifications

nRF24LE1 is packaged in three QFN-packages:

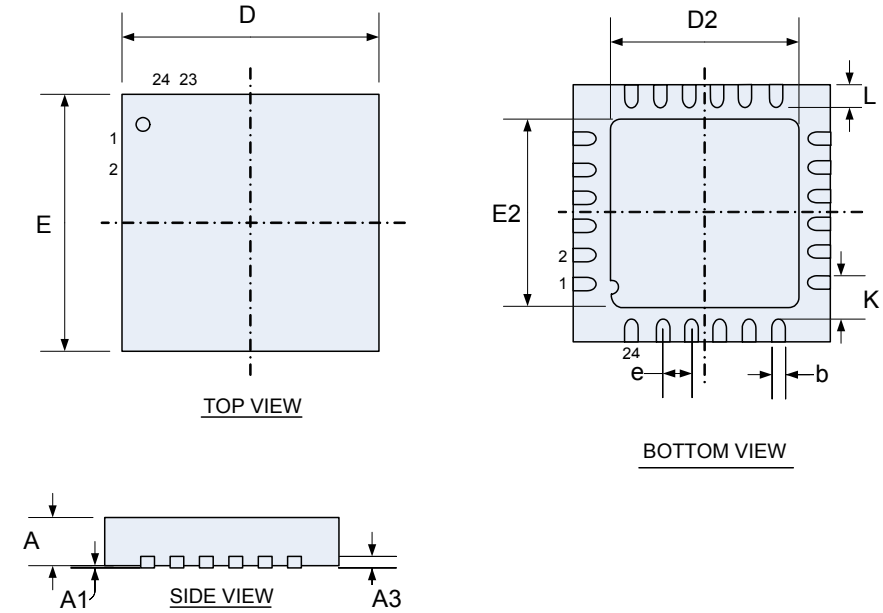

Figure 76. QFN24 pin 4×4mm

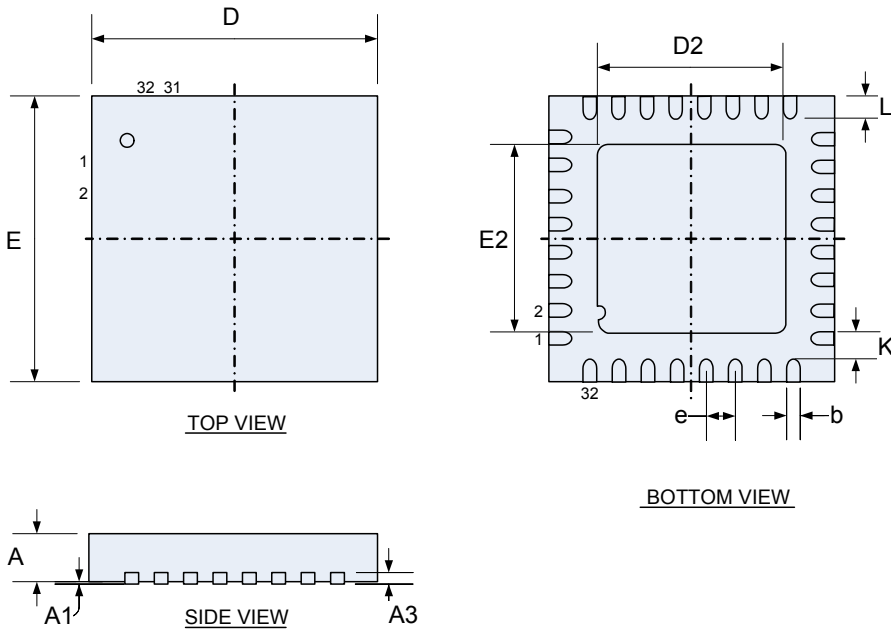

Figure 77. QFN32 pin 5×5mm

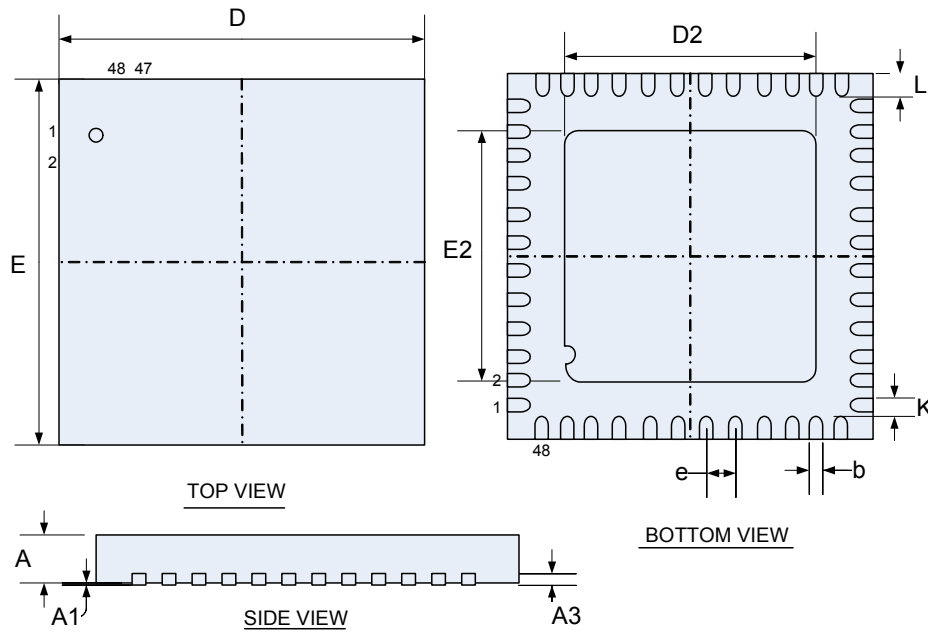

Figure 78. QFN48 pin 7x7mm

Package	A	A1	A3	b	D, E	D2, E2	e	K	L	
QFN24	0.80	0.00		0.18	3.9	2.60		0.20	0.35	Min
	0.85	0.02	0.203	0.25	4.0	2.70	0.5		0.40	Typ
	0.90	0.05		0.30	4.1	2.80			0.45	Max
QFN32	0.80	0.00		0.18	4.9	3.50		0.20	0.35	Min
	0.85	0.02	0.20	0.25	5.0	3.60	0.5		0.40	Typ
	0.90	0.05		0.30	5.1	3.70			0.45	Max
QFN48	0.80	0.00		0.18	6.9	3.90		0.20	0.35	Min
	0.85	0.02	0.203	0.25	7.0	4.00	0.5		0.40	Typ
	0.90	0.05		0.30	7.1	4.10			0.45	Max

Table 117. QFN24/32/48 dimensions in mm

29 Reference circuits

29.1 Q48 application example

29.1.1 Schematic

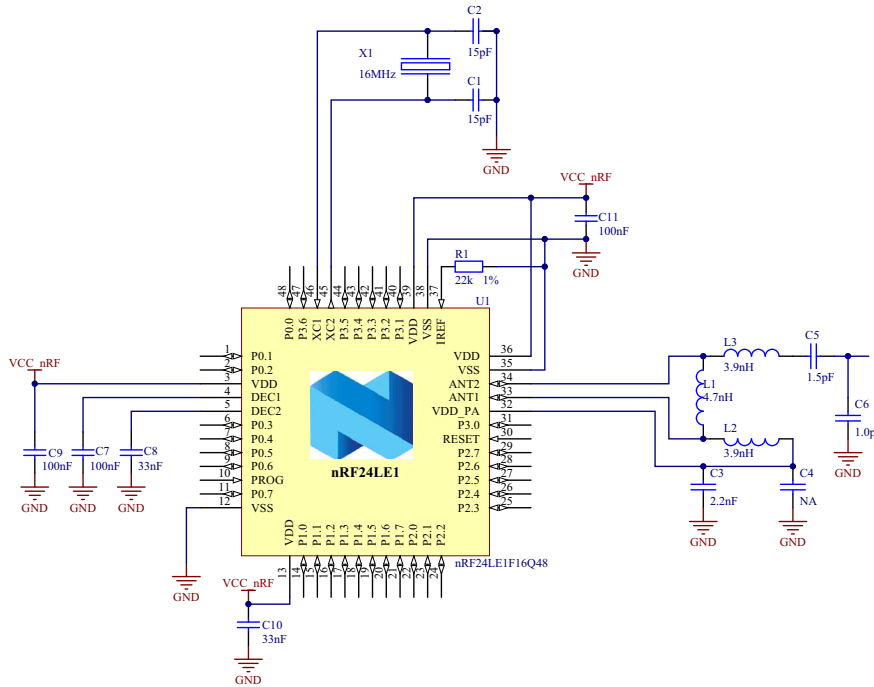
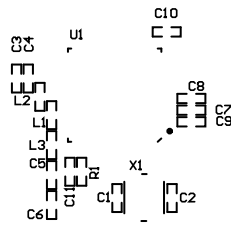

Figure 79. nRF24LE1, 7x7mm QFN48 schematic

29.1.2 Layout



Top silk screen

No components
in bottom layer

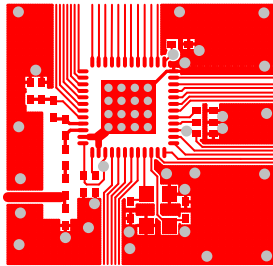

Top view

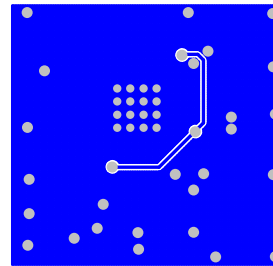

Bottom view

29.1.3 Bill Of Materials (BOM)

Designator	Value	Footprint	Comment
C1, C2	15pF	0402	NP0 +/- 2%
C3	2.2nF	0402	X7R +/- 10%
C4	Not mounted	0402	
C5	1.5pF	0402	NP0 +/-0.1pF
C6	1.0pF	0402	NP0 +/-0.1pF
C7, C9, C11	100nF	0402	X7R +/- 10%
C8, C10	33nF	0402	X7R +/- 10%
L1	4.7nH	0402	High frequency chip inductor +/-5%
L2, L3	3.9nH	0402	High frequency chip inductor +/-5%
R1	22k	0402	1%
U1	nRF24LE1F16Q48	QFN48	QFN48 7x7 mm package
X1	16 MHz	3.2x2.5mm	SMD-3225, 16 MHz, CL=9pF, +/-60 ppm
PCB substrate	FR4 laminate	20.8 x19.9mm	2 layer, thickness 1.6mm

Table 118. nRF24LE1, 7x7mm QFN48 Bill Of Materials

29.2 Q32 application example

29.2.1 Schematic

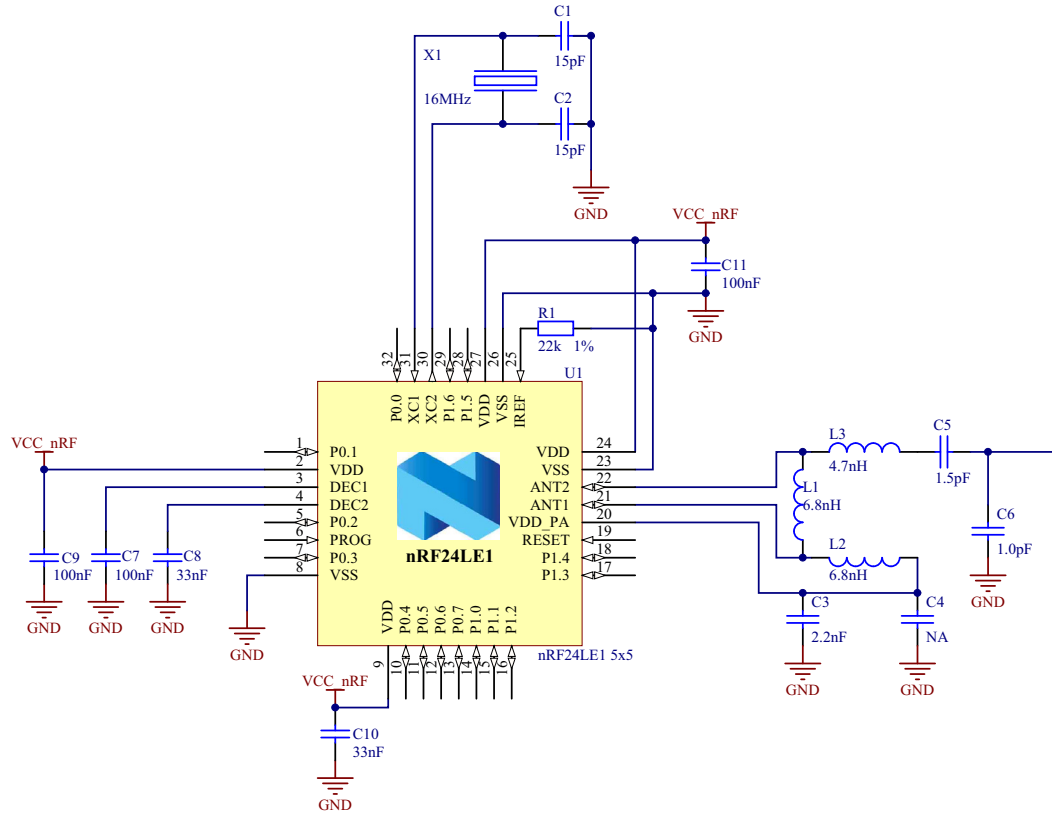
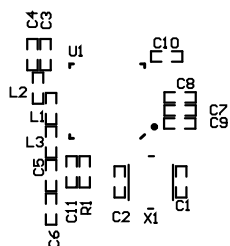

Figure 80. nRF24LE1, 5x5mm QFN32 schematic

29.2.2 Layout



Top silk screen

No components
in bottom layer

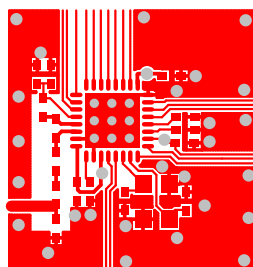

Top view

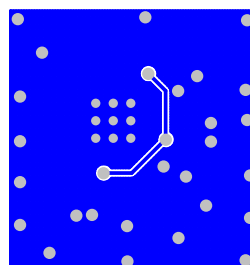

Bottom view

29.2.3 Bill Of Materials (BOM)

Designator	Value	Footprint	Comment
C1, C2	15pF	0402	NP0 +/- 2%
C3	2.2nF	0402	X7R +/- 10%
C4	Not mounted	0402	
C5	1.5pF	0402	NP0 +/-0.1pF
C6	1.0pF	0402	NP0 +/-0.1pF
C7, C9, C11	100nF	0402	X7R +/- 10%
C8, C10	33nF	0402	X7R +/- 10%
L1, L2	6.8nH	0402	High-frequency chip inductor +/-5%
L3	4.7nH	0402	High-frequency chip inductor +/-5%
R1	22k	0402	1%
U1	nRF24LE1F16Q32	QFN32	QFN32 5x5mm package
X1	16 MHz	3.2 × 2.5 mm	TSX-3225, 16 MHz, CL=9pF, +/-60 ppm
PCB substrate	FR4 laminate	16.9 × 17.8 mm	2 layer, thickness 1.6mm

Table 119. nRF24LE1, 5x5mm QFN32 Bill Of Materials

29.3 Q24 application example

29.3.1 Schematic

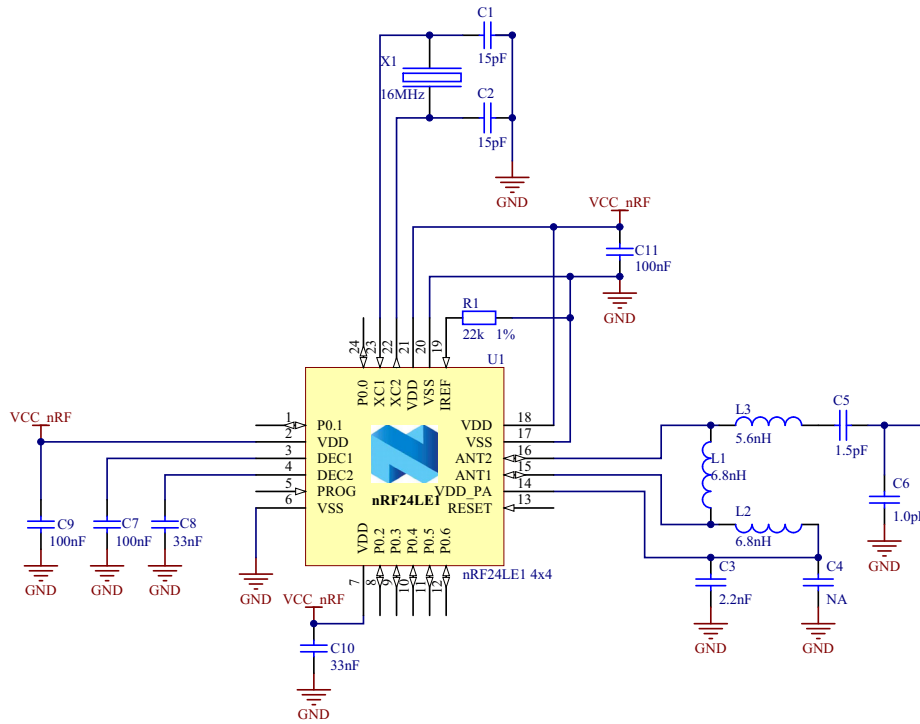
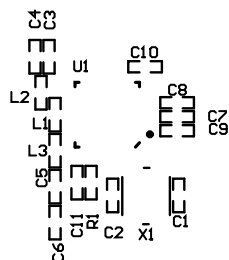

Figure 81. nRF24LE1, 4x4mm QFN24 schematic

29.3.2 Layout



Top silk screen

No components
in bottom layer

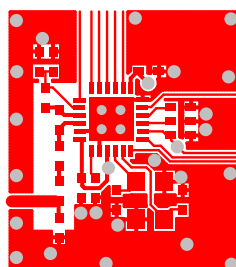

Top view

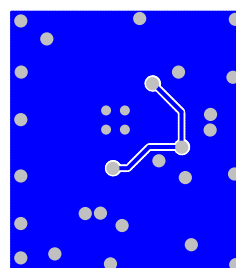

Bottom view

29.3.3 Bill Of Materials (BOM)

Designator	Value	Footprint	Comment
C1, C2	15pF	0402	NP0 +/- 2%
C3	2.2nF	0402	X7R +/- 10%
C4	Not mounted	0402	
C5	1.5pF	0402	NP0 +/-0.1pF
C6	1.0pF	0402	NP0 +/-0.1pF
C7, C9, C11	100nF	0402	X7R 1+/-10%
C8, C10	33nF	0402	X7R +/-10%
L1, L2	6.8nH	0402	High-frequency chip inductor +/-5%
L3	5.6nH	0402	High-frequency chip inductor +/-5%
R1	22k	0402	1%
U1	nRF24LE1F16 Q24	QFN24	QFN24 4x4mm package
X1	16 MHz	3.2x2.5mm	TSX-3225, 16MHz, CL=9pF, +/-60 ppm
PCB substrate	FR4 laminate	14.8x16.6mm	2 layer, thickness 1.6mm

Table 120. nRF24LE1, 4x4mm QFN24 Bill Of Materials

30 Ordering information

30.1 Package marking

N	R	F		B	X
2	4	L	E	1	Z
Y	Y	W	W	L	L

30.1.1 Abbreviations

Abbreviation	Definition
24LE1	Product number
B	Build Code, that is, unique code for production sites, package type and test platform.
X	"X" grade, that is, Engineering Samples (optional).
WW	Two digit week number
LL	Two letter wafer lot number code
Z	Package type. "D" = 24 pin, "E" = 32 pin and "F" = 48 pin
YY	Two digit Year number

Table 121. Abbreviations

30.2 Product options

30.2.1 RF silicon

Ordering code	Package	Container	MOQ
nRF24LE1-F16Q24-T	4×4mm 24-pin QFN, lead free (green)	Tray	490
nRF24LE1-F16Q24-R7	4×4mm 24-pin QFN, lead free (green)	Tape-and-reel	1500
nRF24LE1-F16Q24-R	4×4mm 24-pin QFN, lead free (green)	Tape-and-reel	4000
nRF24LE1-F16Q24-SAMPLE	4×4mm 24-pin QFN, lead free (green)	Sample box	5
nRF24LE1-F16Q32-T	5×5mm 32-pin QFN, lead free (green)	Tray	490
nRF24LE1-F16Q32-R7	5×5mm 32-pin QFN, lead free (green)	Tape-and-reel	1500
nRF24LE1-F16Q32-R	5×5mm 32-pin QFN, lead free (green)	Tape-and-reel	4000
nRF24LE1-F16Q32-SAMPLE	5×5mm 32-pin QFN, lead free (green)	Sample box	5
nRF24LE1-F16Q48-T	7×7mm 48-pin QFN, lead free (green)	Tray	490
nRF24LE1-F16Q48-R7	7×7mm 48-pin QFN, lead free (green)	Tape-and-reel	1500
nRF24LE1-F16Q48-R	7×7mm 48-pin QFN, lead free (green)	Tape-and-reel	4000
nRF24LE1-F16Q48-SAMPLE	7×7mm 48-pin QFN, lead free (green)	Sample box	5

Table 122. nRF24LE1 RF silicon options

30.2.2 Development tools

Type Number	Description
nRF6700	nRFgo Starter Kit
nRF24LE1-F16Q24-DK	nRFgo Development Kit for nRF24LE1 4×4mm 24 pin QFN (requires nRFgo Starter Kit)
nRF24LE1-F16Q32-DK	nRFgo Development Kit for nRF24LE1 5×5mm 32 pin QFN (requires nRFgo Starter Kit)
nRF24LE1-F16Q48-DK	nRFgo Development Kit for nRF24LE1 7×7mm 48 pin QFN (requires nRFgo Starter Kit)

Table 123. nRF24LE1 solution options

31 Glossary

Term	Description
ACK	Acknowledgement
ADC	Analog to digital converter
ART	Auto Re-Transmit
BOR	Brown-Out Reset
CE	Chip Enable
CLK	Clock
CRC	Cyclic Redundancy Check
CSN	Chip Select NOT
ESB	Enhanced ShockBurst™
GFSK	Gaussian Frequency Shift Keying
IRQ	Interrupt Request
ISM	Industrial-Scientific-Medical
LNA	Low Noise Amplifier
LSB	Least Significant Bit
LSByte	Least Significant Byte
Mbps	Megabit per second
MCU	Microcontroller
MOQ	Minimum Order Quantity
MISO	Master In Slave Out
MOSI	Master Out Slave In
MSB	Most Significant Bit
MSByte	Most Significant Byte
NV	Non-Volatile (memory)
PCB	Printed Circuit Board
PER	Packet Error Rate
PID	Packet Identity Bits
PLD	Payload
POF	Power Fail
POR	Power On Reset
PRX	Primary RX
PTX	Primary TX
PWR_DWN	Power Down
PWR_UP	Power Up
RCOSC16M	16 MHz RC oscillator
RCOSC32K	32 KHz RC oscillator
RNG	Random Number Generator
RX	Receive
RX_DR	Receive Data Ready
SPI	Serial Peripheral Interface
TX	Transmit
TX_DS	Transmit Data Sent
XOSC16M	16 MHz crystal oscillator
XOSC32K	32 KHz crystal oscillator

Table 124. Glossary

Данный компонент на территории Российской Федерации

Вы можете приобрести в компании MosChip.

Для оперативного оформления запроса Вам необходимо перейти по данной ссылке:

<http://moschip.ru/get-element>

Вы можете разместить у нас заказ для любого Вашего проекта, будь то серийное производство или разработка единичного прибора.

В нашем ассортименте представлены ведущие мировые производители активных и пассивных электронных компонентов.

Нашей специализацией является поставка электронной компонентной базы двойного назначения, продукции таких производителей как XILINX, Intel (ex.ALTERA), Vicor, Microchip, Texas Instruments, Analog Devices, Mini-Circuits, Amphenol, Glenair.

Сотрудничество с глобальными дистрибьюторами электронных компонентов, предоставляет возможность заказывать и получать с международных складов практически любой перечень компонентов в оптимальные для Вас сроки.

На всех этапах разработки и производства наши партнеры могут получить квалифицированную поддержку опытных инженеров.

Система менеджмента качества компании отвечает требованиям в соответствии с ГОСТ Р ИСО 9001, ГОСТ РВ 0015-002 и ЭС РД 009

Офис по работе с юридическими лицами:

105318, г.Москва, ул.Щербаковская д.3, офис 1107, 1118, ДЦ «Щербаковский»

Телефон: +7 495 668-12-70 (многоканальный)

Факс: +7 495 668-12-70 (доб.304)

E-mail: info@moschip.ru

Skype отдела продаж:

moschip.ru

moschip.ru_4

moschip.ru_6

moschip.ru_9