

MAX20336 Evaluation Kit

Evaluates: MAX20336

General Description

The MAX20336 evaluation kit (EV kit) is a fully assembled and tested circuit board that demonstrates the MAX20336 beyond-the-rails DPST analog switches. The EV kit comes with the MAX20336ENT+ installed.

Features

- USB Power Option
- SMA Connection for Testing
- Proven PCB Layout
- Fully Assembled and Tested

EV Kit Contents

- EV Kit Board Containing a MAX20336 IC Part

Quick Start

Required Equipment

- MAX20336 EV kit
- USB Cable or Power Supply

Procedure

The EV kit is fully assembled and tested. Follow the steps below to verify board operation:

- 1) Connect a USB cable to J1 or power VB (TP1) with 5V power supply.
- 2) NO1 is connected to COM1 and NO2 is connected to COM2.

Detailed Description

The MAX20336 EV kit is a fully assembled and tested circuit board demonstrating the MAX20336 DPST switches in a 6-bump WLP package.

Power Supply

The EV kit can power the V_{CCEN} pin of the IC from different sources. Alternatively, on the MAX20336 EV kit, the IC can be powered externally from TP12.

Table 1. Power Supply Jumper Setting

JUMPER	SHUNT POSITION	DESCRIPTION
JU1	1-2*	V_{CCEN} of the IC is connected to VCC of the EV kit
	2-3	V_{CCEN} of the IC is connected to ground of the EV kit
JU2	1-2	VCC is connected to VEXT, TP3
	3-4*	VCC is connected to VHH, output of LDO
	5-6	VCC is connected to VB, supply from USB
JU3	1-2*	1.8V LDO output
	3-4	2.5V LDO output
	5-6	3.3V LDO output
	7-8	Variable LDO output

*Default position.

Ordering Information

PART	TYPE
MAX20336EVKIT#	EV KIT

#Denotes RoHS compliant.

MAX20336 EV Kit Bill of Materials

ITEM	REF_DES	QTY	MFG PART #	MANUFACTURER	VALUE	DESCRIPTION
1	C1	1	GRM21BR71E155KA	MURATA	1.5UF	CAPACITOR; SMT (0805); CERAMIC CHIP; 1.5UF; 25V; TOL=10%; MODEL=X7R; TG=-55 DEGC TO +125 DEGC; TC=+/-
2	C2	1	C1608X7R1E104K080AA	TDK	0.1UF	CAPACITOR; SMT (0603); CERAMIC CHIP; 0.1UF; 25V; TOL=10%; MODEL=C SERIES; TG=-55 DEGC TO +125 DEGC; TC=X7R
3	C3	1	C1608X5R1V225K080AC; GRM188R6YA225KA12	TDK;MURATA	2.2UF	CAPACITOR; SMT (0603); CERAMIC CHIP; 2.2UF; 35V; TOL=10%; TG=-55 DEGC TO +85 DEGC; TC=X5R
4	C4	1	C1608X5R1V475K080AC	TDK	4.7UF	CAP; SMT (0603); 4.7UF; 10%; 35V; X5R; CERAMIC CHIP
5	J1	1	ZX62-B-5PA(33)	HIROSE ELECTRIC CO LTD.	ZX62-B-5PA(33)	CONNECTOR; MALE; SMT; USB MICRO B-TYPE; BOTTOM MOUNT; RIGHT ANGLE; 5PINS
6	J2, J3	2	SJ1-3523NG	CUI INC.	SJ1-3523NG	CONNECTOR; FEMALE; THROUGH HOLE; 3.5MM NO SWITCH JACK STEREO, RIGHT ANGLE; 3PINS
7	J4-J7	4	5-1814832-1	TYCO	5-1814832-1	CONNECTOR; FEMALE; THROUGH HOLE; CONN SOCKET SMA STR DIE CAST PCB; STRAIGHT; 5PINS
8	JU1	1	PEC03SAAN	SULLINS	PEC03SAAN	CONNECTOR; MALE; THROUGH HOLE; BREAKAWAY; STRAIGHT; 3PINS
9	JU2	1	PEC03DAAN	SULLINS ELECTRONICS CORP.	PEC03DAAN	CONNECTOR; MALE; THROUGH HOLE; BREAKAWAY; STRAIGHT THROUGH; 6PINS; -65 DEGC TO +125 DEGC
10	JU3	1	PEC04DAAN	SULLINS ELECTRONICS CORP.	PEC04DAAN	CONNECTOR; MALE; THROUGH HOLE; BREAKAWAY; STRAIGHT; 8PINS
11	MH1-MH4	4	9032	KEYSTONE	9032	MACHINE FABRICATED; ROUND-THRU HOLE SPACER; NO THREAD; M3.5; 5/8IN; NYLON
12	R1	1	CRCW0805232KFK	VISHAY DALE	232K	RESISTOR; 0805; 232K OHM; 1%; 100PPM; 0.125W; THICK FILM
13	R2, R4-R6	4	CRCW0805100KFK; RK73H2ATTD1003;ERJ-6ENF1003	VISHAY DALE;KOA SPEER;PANASONIC	100K	RESISTOR; 0805; 100K; 1%; 100PPM; 0.125W; THICK FILM
14	R3	1	ERJ-6ENF6192	PANASONIC	61.9K	RESISTOR; 0805; 61.9K OHM; 1%; 100PPM; 0.125W; THICK FILM
15	R7	1	PV37W504C01B00	MURATA	500K	RESISTOR; THROUGH-HOLE-RADIAL LEAD; 500K OHM; 10%; 150PPM; 0.25W; MOLDER CERAMIC OVER METAL FILM
16	TP1, TP3-TP5, TP12	5	5000	KEYSTONE	N/A	TEST POINT; PIN DIA=0.1IN; TOTAL LENGTH=0.3IN; BOARD HOLE=0.04IN; RED; PHOSPHOR BRONZE WIRE SILVER PLATE FINISH;
17	TP2, TP6, TP10, TP13	4	5001	KEYSTONE	N/A	TEST POINT; PIN DIA=0.1IN; TOTAL LENGTH=0.3IN; BOARD HOLE=0.04IN; BLACK; PHOSPHOR BRONZE WIRE SILVER PLATE FINISH;
18	TP7-TP9, TP11	4	5002	KEYSTONE	N/A	TEST POINT; PIN DIA=0.1IN; TOTAL LENGTH=0.3IN; BOARD HOLE=0.04IN; WHITE; PHOSPHOR BRONZE WIRE SILVER;
19	U1	1	MAX20336ENT+	MAXIM	MAX20336ENT+	EVKIT PART - IC; ULTRA-SMALL; LOW-RON; BEYOND-THE-RAILS DPST ANALOG SWITCH; PACKAGE OUTLINE NUMBER: 21-100308; PACKAGE CODE: N60K1+1
20	U2	1	MAX8880EUT+	MAXIM	MAX8880EUT+	IC; VREG; ULTRA-LOW-IQ LOW-DROPOUT LINEAR REGULATOR WITH POK; SOT23-6
21	PCB	1	MAX20336	MAXIM	PCB	PCB:MAX20336
TOTAL		41				

MAX20336 EV Kit Schematic

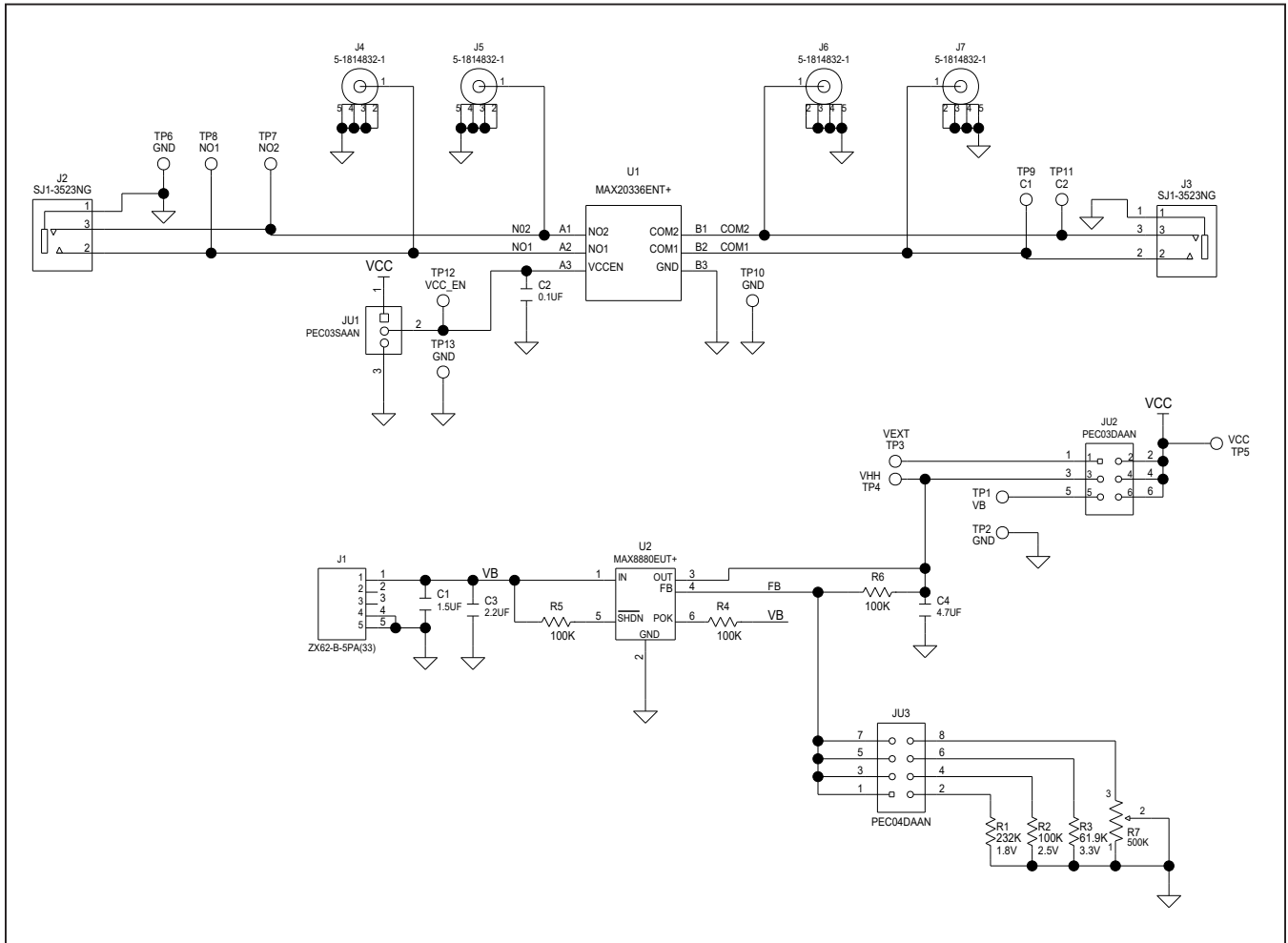

MAX20336 EV Kit PCB Layout

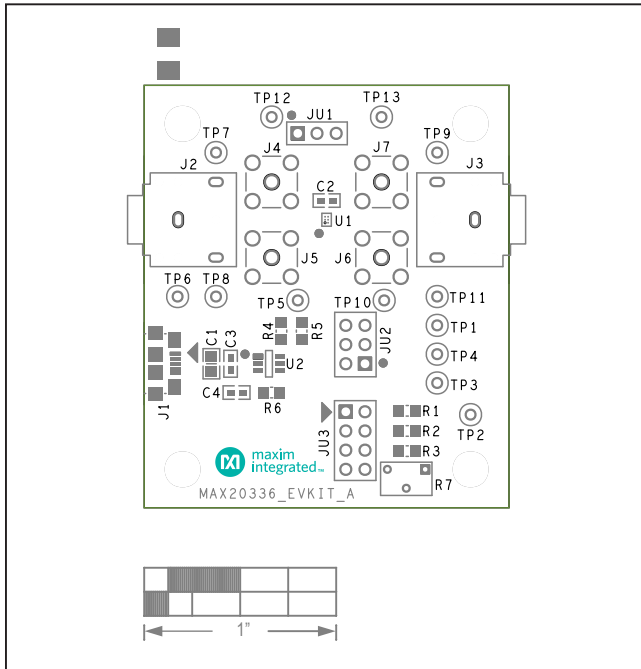

Silk Top

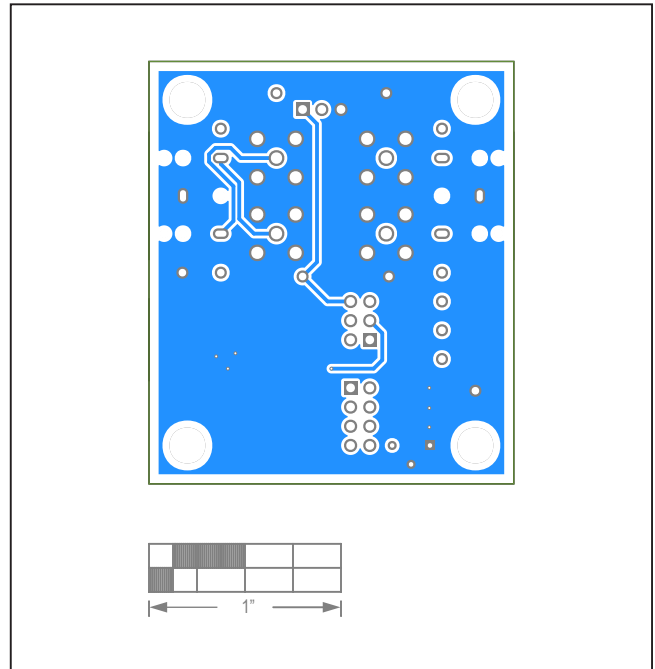

Bottom

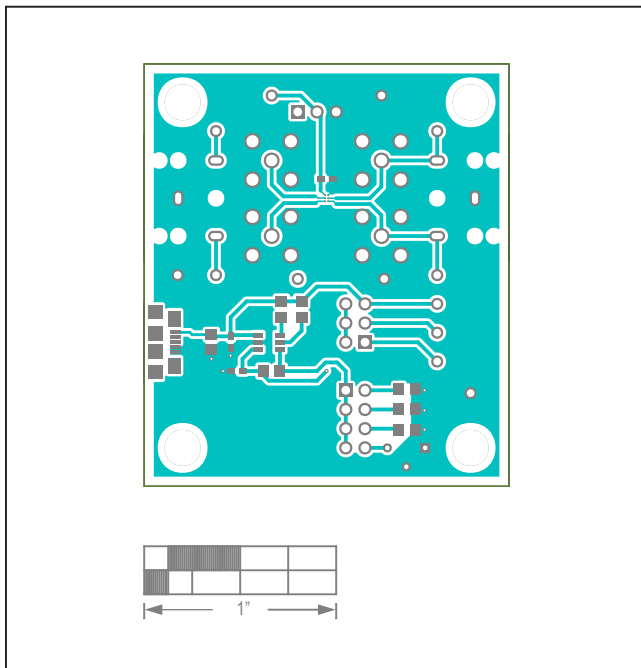

Top

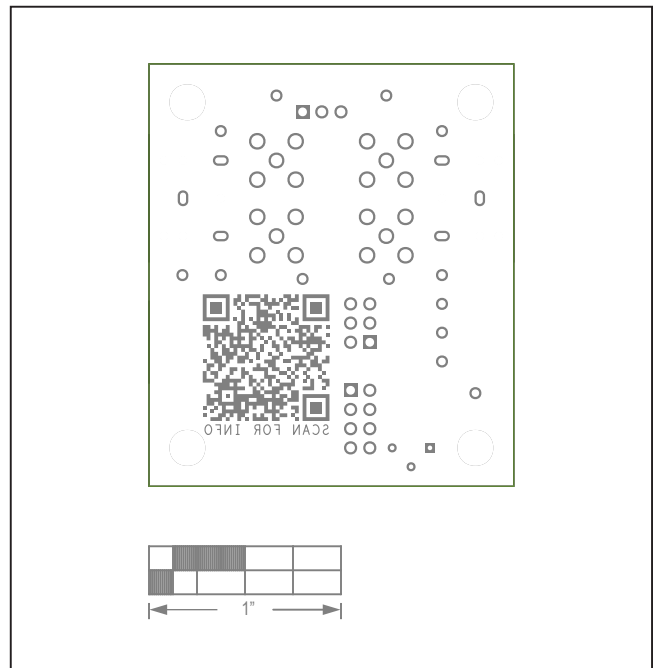

Silk Bottom

Revision History

REVISION NUMBER	REVISION DATE	DESCRIPTION	PAGES CHANGED
0	1/19	Initial release	—

For pricing, delivery, and ordering information, please visit Maxim Integrated's online storefront at <https://www.maximintegrated.com/en/storefront/storefront.html>.

Maxim Integrated cannot assume responsibility for use of any circuitry other than circuitry entirely embodied in a Maxim Integrated product. No circuit patent licenses are implied. Maxim Integrated reserves the right to change the circuitry and specifications without notice at any time.

Данный компонент на территории Российской Федерации

Вы можете приобрести в компании MosChip.

Для оперативного оформления запроса Вам необходимо перейти по данной ссылке:

<http://moschip.ru/get-element>

Вы можете разместить у нас заказ для любого Вашего проекта, будь то серийное производство или разработка единичного прибора.

В нашем ассортименте представлены ведущие мировые производители активных и пассивных электронных компонентов.

Нашей специализацией является поставка электронной компонентной базы двойного назначения, продукции таких производителей как XILINX, Intel (ex.ALTERA), Vicor, Microchip, Texas Instruments, Analog Devices, Mini-Circuits, Amphenol, Glenair.

Сотрудничество с глобальными дистрибьюторами электронных компонентов, предоставляет возможность заказывать и получать с международных складов практически любой перечень компонентов в оптимальные для Вас сроки.

На всех этапах разработки и производства наши партнеры могут получить квалифицированную поддержку опытных инженеров.

Система менеджмента качества компании отвечает требованиям в соответствии с ГОСТ Р ИСО 9001, ГОСТ РВ 0015-002 и ЭС РД 009

Офис по работе с юридическими лицами:

105318, г.Москва, ул.Щербаковская д.3, офис 1107, 1118, ДЦ «Щербаковский»

Телефон: +7 495 668-12-70 (многоканальный)

Факс: +7 495 668-12-70 (доб.304)

E-mail: info@moschip.ru

Skype отдела продаж:

moschip.ru

moschip.ru_4

moschip.ru_6

moschip.ru_9