

1/3 , 1/4 Duty LCD Driver

■ GENERAL DESCRIPTION

The **NJU6535** is a 1/3 or 1/4 duty LCD driver for segment type LCD panel with key scan function transmitting the 30 keys maximum scanned data (6 x 5 = 30) to CPU.

The **NJU6535** chooses numbers of common, key scan, and general purpose ports by instructions. Therefore, It drives 126 segments at 1/3 duty in use of 3 commons and 42 segments or 164 segments at 1/4 duty in use of 4 and 41. Also it provides 4 general purpose output ports maximum to drive LEDs or others directly.

Furthermore, the NJU6535 can select a LCD driving voltage out of 8 steps voltage by the instruction to adjust the display contrast of LCD panel.

■ PACKAGE OUTLINE



NJU6535FG1



NJU6535FH1

■ FEATURES

- 42-segment Drivers
- Programmable Duty Ratio
 - 1/3 Duty : 126-segment (Maximum)
 - 1/4 Duty : 164-segment (Maximum)
- 30-key Scan Function (6X5 matrix)
 - Needless for anti-reverse current diodes in key scan
- Programmable Bias Ratio 1/2, 1/3 bias
- Output Port for LED (maximum 4 LED)
- Serial Interface (SI, SO, SCL, CS)
- Useful Instruction set
- Incorporated LCD Driving Voltage Generator Circuits
- Electrical Variable Resistance (8-step)
- Logic Operating Voltage 4.5 ~ 5.5V
- LCD Driving Voltage ~5.5V
- Package Outline QFP64-G1
QFP64-H1
- C-MOS Technology (Substrate :P)

NJU6535

PIN LOCATION

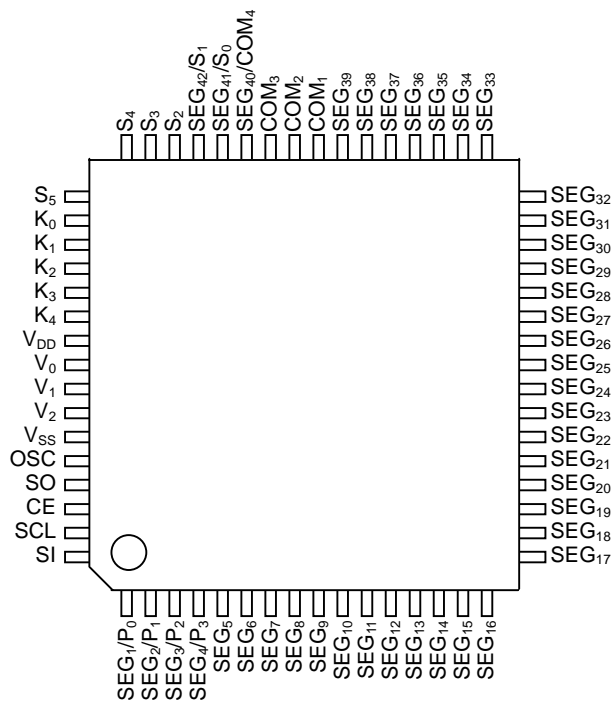

BLOCK DIAGRAM

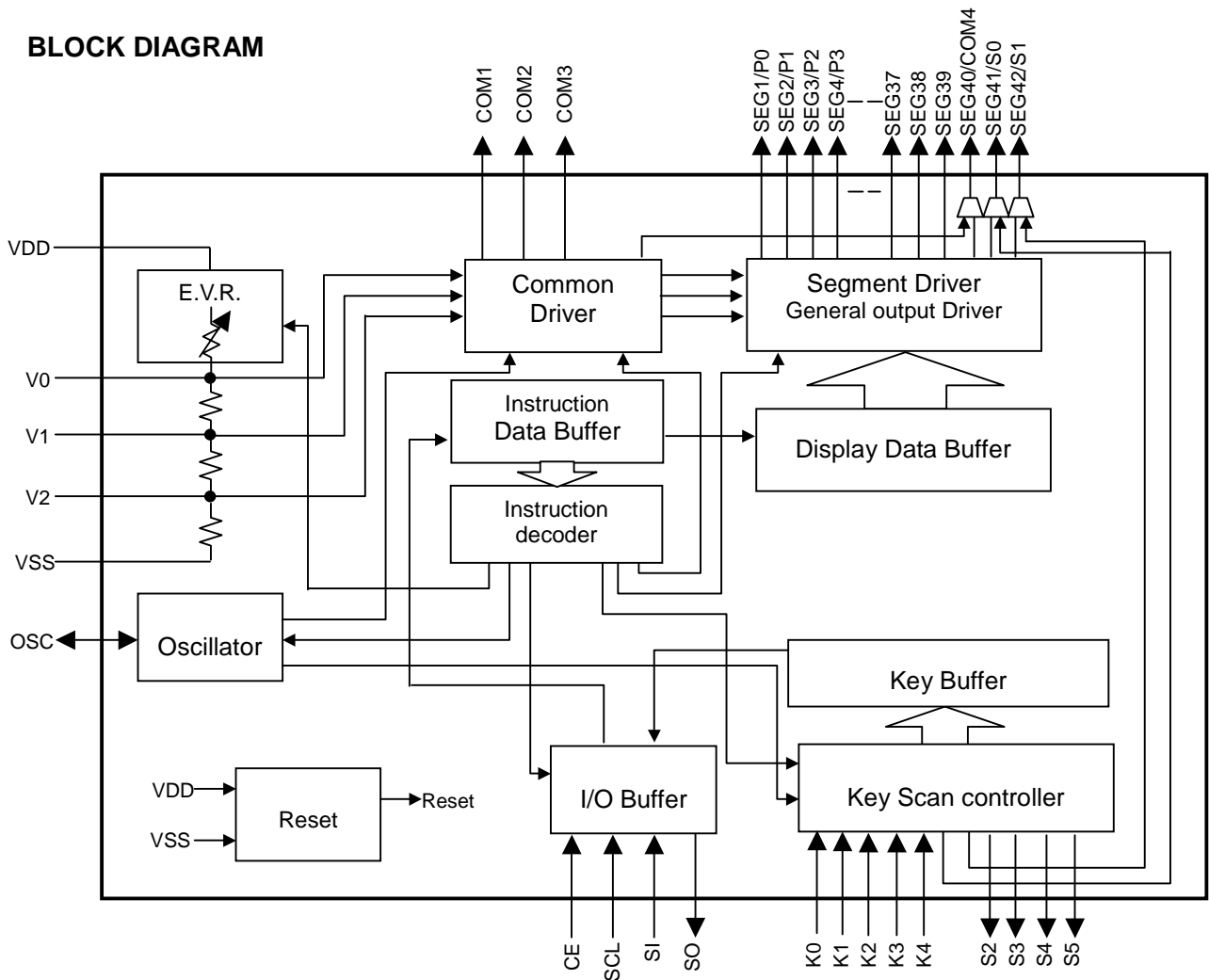

■ TERMINAL DESCRIPTION 1

No.	SYMBOL	I/O	FUNCTION
1 2 3 4	SEG1/P0 SEG2/P1 SEG3/P2 SEG4/P3	O	LCD Segment output terminal / General output terminal. Select Segment output terminal or General output terminal by the instruction.
5 to 39	SEG5 to SEG39	O	LCD Segment output terminal
40 41 42	COM1 COM2 COM3	O	LCD Common output terminal
43	SEG40/COM4	O	LCD Segment output terminal / LCD Common output terminal SEG40 in 1/3Duty use, COM4 in 1/4Duty use.
44 45	SEG41/S0 SEG42/S1	O	LCD Segment output terminals / key scanning output terminals Select Segment output terminal or key scanning output terminal by the instruction. (No need for anti-reverse current diode in key scan)
46 47 48 49	S2 to S6	O	Key scanning output terminals. (No need for anti-reverse current diode in key scan)
50 to 54	K0 to K4	I	Key scanning input terminals. (with internal pull-down resistor)
55	V _{DD}	-	Power source: VDD=5V with LCD driving voltage input.
56 57 58	V ₀ V ₁ V ₂	I	LCD driving voltage stabilization capacitor terminals. In use of 1/2 bias, connects V ₁ to V ₂ .
59	V _{SS}	-	GND: VSS=0V
60	OSC	I/O	System clock input terminal This terminal should be open for internal clock operation. Change Oscillation frequency by connecting capacitor and resistor. Inputs external oscillation clock.
61	SO	O	Data output terminal.
62	CE	I	Chip enable terminal.
63	SCL	I	Shift clock input terminal.
64	SI	I	Data input terminal.

■ FUNCTIONAL DESCRIPTION

(1) Description for each blocks

(1-1) Serial I/F

The Serial I/F controls serial data from external data.

(1-2) Instruction Reg.

The Instruction Register stores instruction code from external.

(1-3) Instruction Decoder.

The instruction decoder decodes instruction code and controls each blocks

(1-4) Data Buffer for Display.

The Data Buffer for Display stores data for display from external.

(1-5) Segment Driver / General output Driver.

The Segment Driver generates driving waveform to Segment terminal on Display data.

The General output Driver generates "H" or "L" level to General output terminal on output data.

(1-6) Common Driver.

The Common Driver generates driving waveform to Common terminal .

(1-7) Electrical Variable Resistance (E.V.R.)

The Electrical Variable Resistance adjusts LCD Driving Voltage from V0 to V2.

(1-8) Key Scan Controller.

The Key Scan Controller controls to input from external KEY data.

(1-9) Data buffer for Key.

The Data buffer for key stores Key Data until next key data is stored.

(1-10) CR Oscillator

The Oscillator is CR oscillator which generates the master clock.

(1-11) Reset Circuit

The Reset circuit is type of detectable voltage. It resets internal circuit when the power turns on or drop the voltage.

The Reset circuit is initializes the **NJU6535** at Power ON and OFF. It generates reset signal to initialize the system at low VDD less than power down detection voltage (2.5V typical).

■ INSTRUCTIONS

The instruction code is consisted of 12-bits data and inputs with display data. (see "Table 1 Instruction Code").

Table 1. Instruction Code

DY	E0	E1	E2	S0	S1	K0	K1	P0	P1	SC	DR
----	----	----	----	----	----	----	----	----	----	----	----

Instruction	Symbol	Description
Duty Select	DY	Set the 1/3duty or 1/4duty. 0: 1/3 Duty 1: 1/4 Duty
EVR Register Set	E0-E2	Set the contraction for 000 – 111 (8-voltage conditions)
Power Save mode set	S0-S1	00: Normal 01: Power save 1 10: Power save 2 11: Power save 3
Segment output / Key scan output selection	K0, K1	00: 30 keys 01: 25 keys 1x: 20 keys "x" is Don't care
Segment output / General output port selection	P0, P1	00: 4 segment outputs 01: 2 General output ports 10: 3 General output ports 11: 4 General output ports
Display ON / OFF	SC	0: Display ON 1: Display OFF
Bias selection	DR	0: 1/3 bias 1: 1/2 bias (connect V1 to V2 terminal)

(2) INSTRUCTIONS CODE

(2-1) Duty select

Duty select instruction is which sets LCD driving duty ratio 1/3 or 1/4 duty.
No.43 terminal is change Common terminal or segment terminal shown below.

Table 1

DY	Duty ratio	No.40 to 43 terminal states			
		No.40	No.41	No.42	No.43
0	1/3 Duty	COM1	COM2	COM3	SEG40
1	1/4 Duty	COM1	COM2	COM3	COM4

(2-2) E.V.R. resister set

E.V.R. resister set instruction adjusts the contrast of the LCD, and selects.
One LCD driving voltage VLCD out of 8 voltage-stages by setting E.V.R. register.
Set the binary code "000" when contrast adjustment is unused.

E0	E1	E2	VLCD		VLCD (VLCD=V0-VSS)
			1/2 bias	1/3 bias	
0	0	0	VDD	VDD	High
0	0	1	0.933VDD	0.955VDD	:
0	1	0	0.875VDD	0.913VDD	:
0	1	1	0.824VDD	0.875VDD	:
1	0	0	0.778VDD	0.840VDD	:
1	0	1	0.737VDD	0.808VDD	:
1	1	0	0.700VDD	0.778VDD	:
1	1	1	0.667VDD	0.750VDD	Low

(2-3) Power save mode set

Power save mode reduces the operating current of application using Display Off and selects a terminal condition of Key scan signal output. The terminal, which is set to "L", does not output Key scan signal as shown in following table.

S0	S1	Function	Internal OSC.	LCD output	Key scanning output terminals states *1					
					S0	S1	S2	S3	S4	S5
0	0	Normal	ON	ON	H	H	H	H	H	H
0	1	Power save 1	Stop	Display Off	L	L	L	L	L	H
1	0	Power save 2	Stop	Display Off	L	L	L	L	H	H
1	1	Power save 3	Stop	Display Off	H	H	H	H	H	H

*1 No scanning states.

(2-4) Segment output / key scan output selection

This instruction assigns a function of output terminal either segment output or Key scan signal output to 5 terminals numbered from 44 to 45 as shown in following table.

K0	K1	Maximum key matrix	No.44 to 49 terminal states					
			No.44	No.45	No.46	No.47	No.48	No.49
0	0	30 key	S0	S1	S2	S3	S4	S5
0	1	25 key	SEG41	S1	S2	S3	S4	S5
1	*	20 key	SEG41	SEG42	S2	S3	S4	S5

(*:Don't care)

(2-5) **Segment output / General output port selection**

This instruction assigns function of output terminal either segment output or general purpose output port to 4 terminals numbered from 1 to 4 as shown in following table.

P0	P1	General output ports	No.1 to 4 terminal states			
			No.1	No.2	No.3	No.4
0	0	0 port	SEG1	SEG2	SEG3	SEG4
0	1	2 ports	P0	P1	SEG3	SEG4
1	0	3 ports	P0	P1	P2	SEG4
1	1	4 ports	P0	P1	P2	P3

(2-6) **Display ON / OFF**

Display ON / OFF instruction controls the whole Display On / Off.

SC	Function
0	Display On.
1	Display Off. All segment drivers output OFF waveform. Common waveform does not change.

(2-7) **Bias selection**

This instruction selects a LCD driving bias either 1/3 bias or 1/4 as shown in following table.

DR	Function
0	1/3 bias select
1	1/2 bias select (Connect V1 to V2 terminal)

(3) Display data and output pin correspondence

(3-1) 1/3Duty

Output terminal	COM1	COM2	COM3
SEG ₁	D1	D2	D3
SEG ₂	D4	D5	D6
SEG ₃	D7	D8	D9
SEG ₄	D10	D11	D12
SEG ₅	D13	D14	D15
SEG ₆	D16	D17	D18
SEG ₇	D19	D20	D21
SEG ₈	D22	D23	D24
SEG ₉	D25	D26	D27
SEG ₁₀	D28	D29	D30
SEG ₁₁	D31	D32	D33
SEG ₁₂	D34	D35	D36
SEG ₁₃	D37	D38	D39
SEG ₁₄	D40	D41	D42
SEG ₁₅	D43	D44	D45
SEG ₁₆	D46	D47	D48
SEG ₁₇	D49	D50	D51
SEG ₁₈	D52	D53	D54
SEG ₁₉	D55	D56	D57
SEG ₂₀	D58	D59	D60
SEG ₂₁	D61	D62	D63

Output terminal	COM1	COM2	COM3
SEG ₂₂	D64	D65	D66
SEG ₂₃	D67	D68	D69
SEG ₂₄	D70	D71	D72
SEG ₂₅	D73	D74	D75
SEG ₂₆	D76	D77	D78
SEG ₂₇	D79	D80	D81
SEG ₂₈	D82	D83	D84
SEG ₂₉	D85	D86	D87
SEG ₃₀	D88	D89	D90
SEG ₃₁	D91	D92	D93
SEG ₃₂	D94	D95	D96
SEG ₃₃	D97	D98	D99
SEG ₃₄	D100	D101	D102
SEG ₃₅	D103	D104	D105
SEG ₃₆	D106	D107	D108
SEG ₃₇	D109	D110	D111
SEG ₃₈	D112	D113	D114
SEG ₃₉	D115	D116	D117
SEG ₄₀	D118	D119	D120
SEG ₄₁	D121	D122	D123
SEG ₄₂	D124	D125	D126

When selected, following data are assigned.

Output terminal	Data
P ₀	D1
P ₁	D4
P ₂	D7
P ₃	D10

(3-2) 1/4Duty

Output terminal	COM1	COM2	COM3	COM4
SEG ₁	D1	D2	D3	D4
SEG ₂	D5	D6	D7	D8
SEG ₃	D9	D10	D11	D12
SEG ₄	D13	D14	D15	D16
SEG ₅	D17	D18	D19	D20
SEG ₆	D21	D22	D23	D24
SEG ₇	D25	D26	D27	D28
SEG ₈	D29	D30	D31	D32
SEG ₉	D33	D34	D35	D36
SEG ₁₀	D37	D38	D39	D40
SEG ₁₁	D41	D42	D43	D44
SEG ₁₂	D45	D46	D47	D48
SEG ₁₃	D49	D50	D51	D52
SEG ₁₄	D53	D54	D55	D56
SEG ₁₅	D57	D58	D59	D60
SEG ₁₆	D61	D62	D63	D64
SEG ₁₇	D65	D66	D67	D68
SEG ₁₈	D69	D70	D71	D72
SEG ₁₉	D73	D74	D75	D76
SEG ₂₀	D77	D78	D79	D80
SEG ₂₁	D81	D82	D83	D84

Output terminal	COM1	COM2	COM3	COM
SEG ₂₂	D85	D86	D87	D88
SEG ₂₃	D89	D90	D91	D92
SEG ₂₄	D93	D94	D95	D96
SEG ₂₅	D97	D98	D99	D100
SEG ₂₆	D101	D102	D103	D104
SEG ₂₇	D105	D106	D107	D108
SEG ₂₈	D109	D110	D111	D112
SEG ₂₉	D113	D114	D115	D116
SEG ₃₀	D117	D118	D119	D120
SEG ₃₁	D121	D122	D123	D124
SEG ₃₂	D125	D126	D127	D128
SEG ₃₃	D129	D130	D131	D132
SEG ₃₄	D133	D134	D135	D136
SEG ₃₅	D137	D138	D139	D140
SEG ₃₆	D141	D142	D143	D144
SEG ₃₇	D145	D146	D147	D148
SEG ₃₈	D149	D150	D151	D152
SEG ₃₉	D153	D154	D155	D156
SEG ₄₁	D157	D158	D159	D160
SEG ₄₂	D161	D162	D163	D164

Note) SEG₄₀ is changed to COM₄

When selected, following data are assigned.

Output terminal	Data
P ₀	D1
P ₁	D5
P ₂	D9
P ₃	D13

(3-3) Display data and segment status

Display data	Segment
"H"	On
"L"	Off

(4) Input Data Format and Timing

Data format is shown below.

When the CE terminal goes to "H" (rising edge) at SCL terminal "H", I/F is data input.

(4-1) 1/3Duty

Data 1 (D1 to D42 and Instruction)

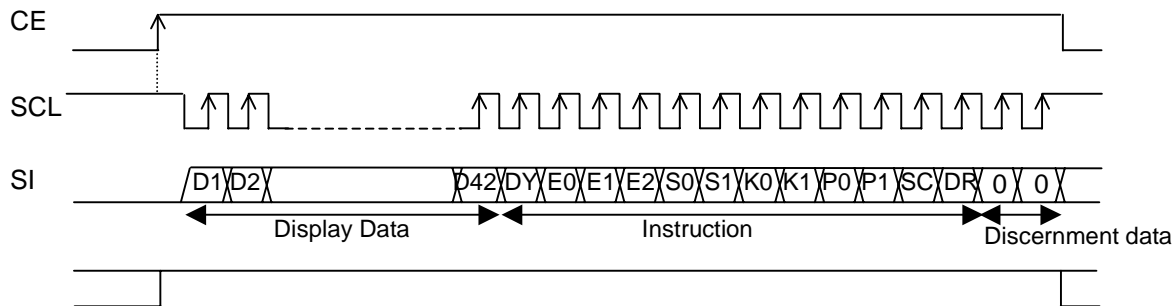

Data 2 (D43 to D84)

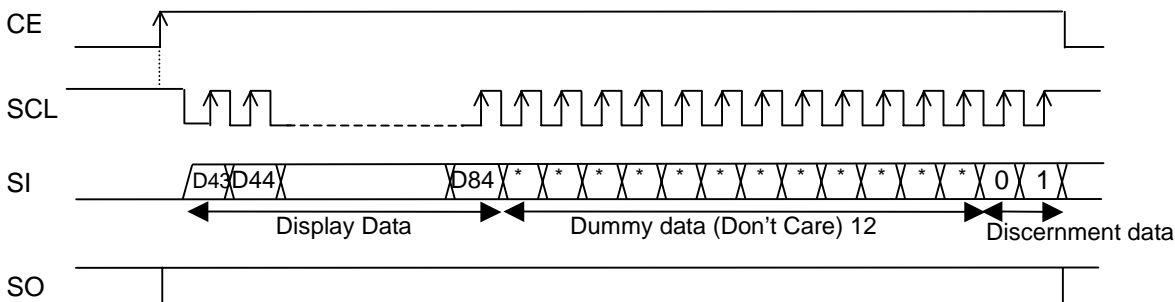

Data 3 (D85 to D126)

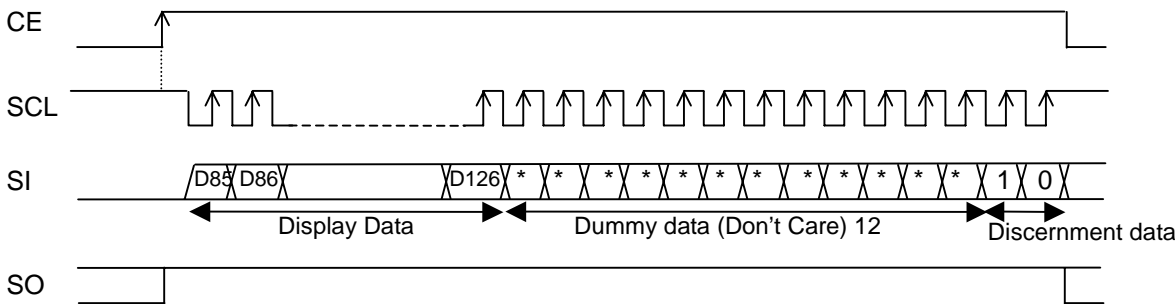

NOTE1) All of display data should be transmitted within 30 mS to keep the display quality, because huge display data D1 to D126 are transmitted at 3 times totally.

NOTE2) Data fetched at SCL rising edge.

NOTE3) Data executed at CE falling edge.

NOTE4) In case of entering less then 56-bit data, invalid data.

NOTE5) In case of entering over then 56-bit data, valid data is last 56-bit data.

(4-2) 1/4Duty

Data 1 (D1 to D44 and Instruction)

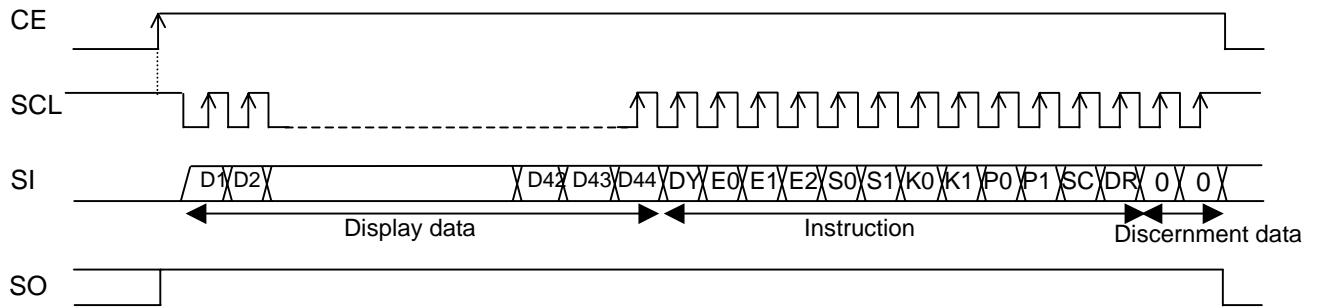

Data 2 (D45 to D84)

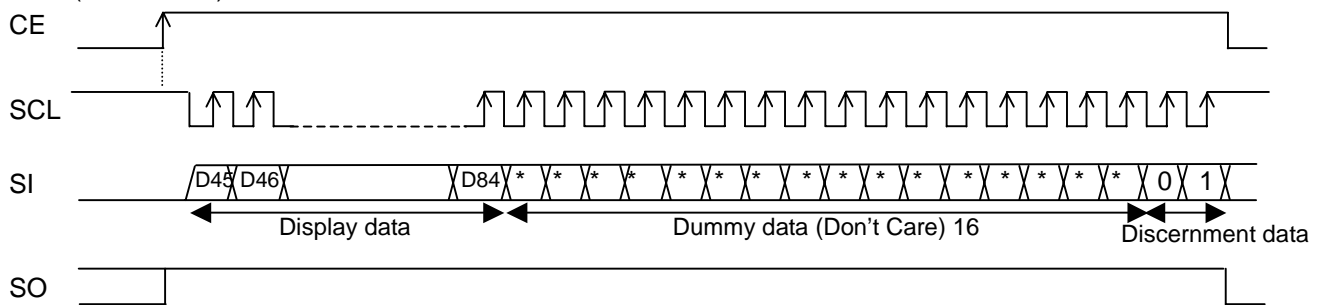

Data 3 (D85 to D124)

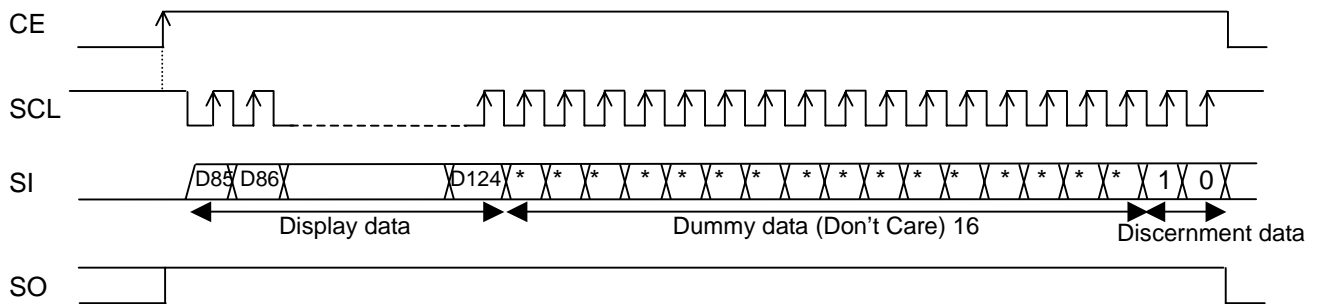

Data 4 (D125 to D164)

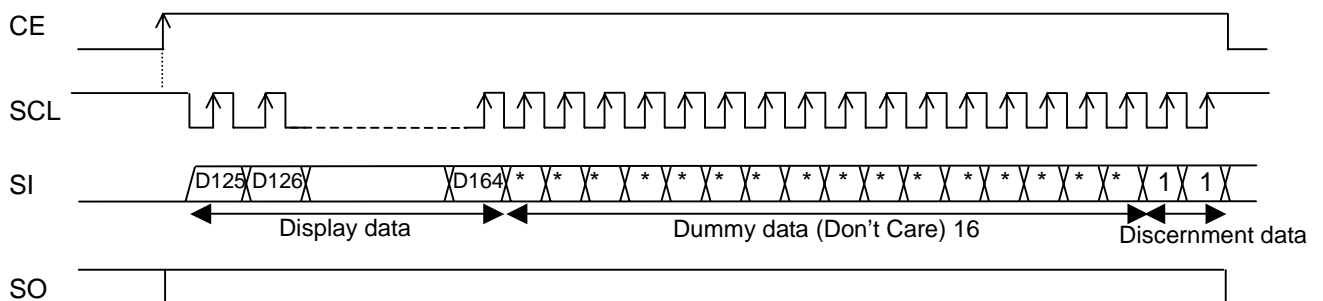

NOTE1) All of display data should be transmitted within 30 mS to keep the display quality, because huge display data D1 to D164 are transmitted at 4 times totally.

NOTE2) Data fetched at SCL rising edge.

NOTE3) Data executed at CE falling edge.

NOTE4) In case of entering less than 58-bit data, invalid data.

NOTE5) In case of entering over than 58-bit data, valid data is last 58-bit data.

NOTE5) Power is turn on time, set the 1/4Duty mode.

(5) Power save mode

Power save mode 1 to 3 is set by “1” level as a control data in PS0 or 1, and released by “0” in PS0 and PS1. In power save mode, segment drivers and commons output “L” level and the internal oscillation circuit is stop the operation (but operates at Key in detection) for operation current reduction.

However, output terminals SEG1/P0 to SEG4/P3 operate as General output port set by control data P0 and P1 in power save mode. (refer (1)Instruction (e)Segment output / General output port)

(6) Key scan circuit

Key scan circuit connects the 6 x 5 key-matrix maximum and reads the data of 30 keys maximum. It chooses the number of keys in key-matrix by “Segment output / key scan output select” instruction. It outputs a identified key data to CPU after comparison with two data read from the key-matrix in twice for reliable key operation. If those data are not identified, key data is not outputted. It outputs “L” signal through “SO” terminal as the request after 577T[s] (T=1/fosc) when any key is operated. Furthermore, the key scan circuit structures for reducing the external components like as Diodes to prevent circuit short problem.

(6-1) The relation between output data and key matrix

The relation between output data and key matrix shows bellow table and sets “1” signal for operated key.

In case of 20 keys application, unassigned area for keys from KD1 to KD10 in bellow table take “0” signal. In case of 25 keys application, unassigned area from KD1 to KD5 take “0” signal also.

In mode of Power save 1, area for keys from KD1 to KD25 in bellow table take “0” signal. In mode of Power save 2, area from KD1 to KD20 take “0” signal also. The terminals, which are not connected any keys, should be open.

	K0	K1	K2	K3	K4
S0	KD1	KD2	KD3	KD4	KD5
S1	KD6	KD7	KD8	KD9	KD10
S2	KD11	KD12	KD13	KD14	KD15
S3	KD16	KD17	KD18	KD19	KD20
S4	KD21	KD22	KD23	KD24	KD25
S5	KD26	KD27	KD28	KD29	KD30

(6-2) Data output timing

The data output format shows bellow. The data output mode is set by “L” status of SCL terminal at the rising signal of CE terminal.

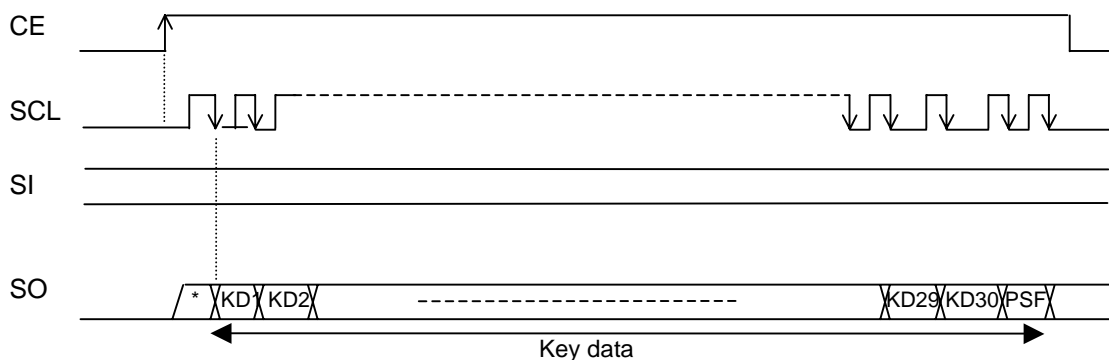

(6-3) Power save flag(PSF)

The status of Power save flag is outputted after KD30 in Key data reading. This flag sets “1” signal in mode of Power save in Key data reading and sets “0” in mode of Normal.

(6-4) Timing of Key scan

Key scan cycle is $288T[S]$. The data of key scan is a result of comparison with a couple of Key scan for correct judge whether Key On or Off. When the result of comparison is correct (accord), the **NJU6535** recognizes Key On and outputs "L" level from SO terminal after $577T[S]$ from start of Key scan for a request to read key data out to external CPU. When the SO terminals outputs "L" signal, the key scan does not operate until end of key data reading by CPU, and scanned key data is kept. When the result of comparison is incorrect (not accord), Key scan operates again if any key is On. Therefore, Key scan may operate incorrectly in case of shorter period of Key on than $577T[S]$

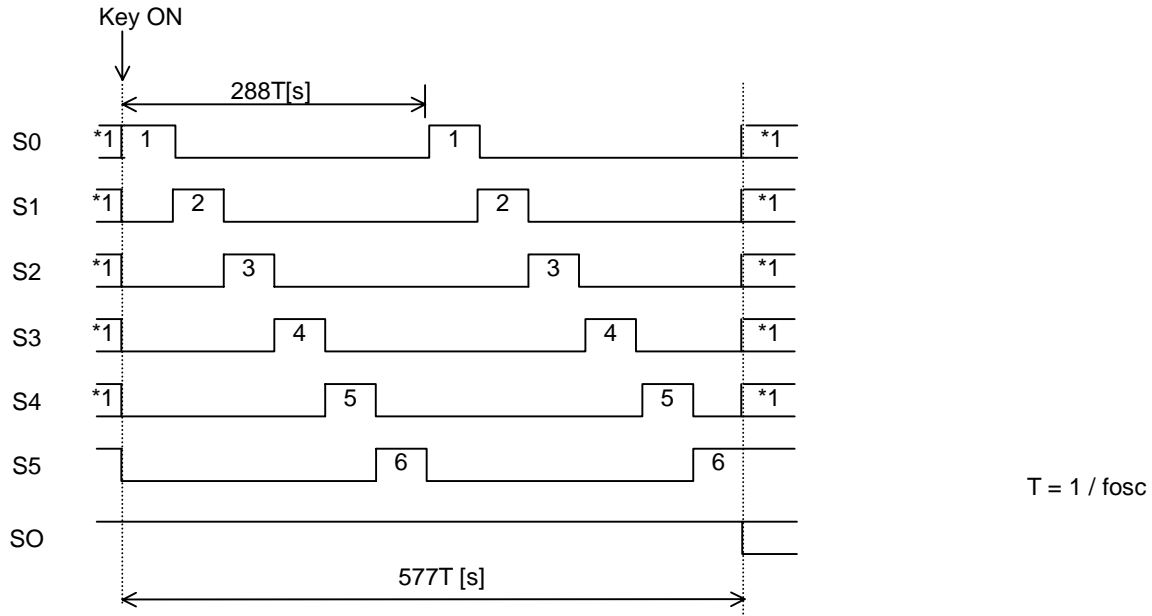

- *1 Instruction data K0, K1 set the output ports to output the scan signals (refer (1)Instruction (2-4)Segment output / Key scan selection)
Key scan cycle and the timing of Key data read out request are constant in any combination of S0, S1, K0 and K1.

(6-5) Normal mode

Key scan operates with follows in normal mode.

- 1, Key scan signal output terminals S0 – S5 output “H” signals when key scan does not operate, and output key scan signals after start of key scan operation. The conditions of key scan signal input terminals K0 – K4 are “L” state with internal pull-down resistances, though “H” signal comes in to K0 – K4 corresponding to the turned on keys.
- 2, The function of key scan starts twice operations when any key is turned on. It stops when a couple of data by continuously twice key scan operations are accorded and fixed as a correct key status. It operates more 2 times when the key status is not fixed and any keys are still turning on. It repeats again and again until key status is fixed. The correct key status data is stored and newly key scan operation does not start until external CPU reads data out after key status is fixed.
- 3, When the key status is fixed, SO terminal outputs “L” signal as Key data read out request to CPU. CPU should read key data out at detection of this “L” signal. If CPU writes the display data or instructions to the NJU6535 when SO terminal outputs “L” signal, SO terminal outputs “H” level during “CE” terminal is “H”.
- 4, The Key data read out request signal is released and SO terminal outputs “H” signal after finish of CPU key data read out for newly key scan operation.

SO terminal requires pull up resistor (1 Kohm to 10 Kohms) because of Open drain type output. Multiple data of key are output in case of key more input so that CPU should process the data by itself.

Key scan example (Normal mode)

$T = 1 / f_{osc}$

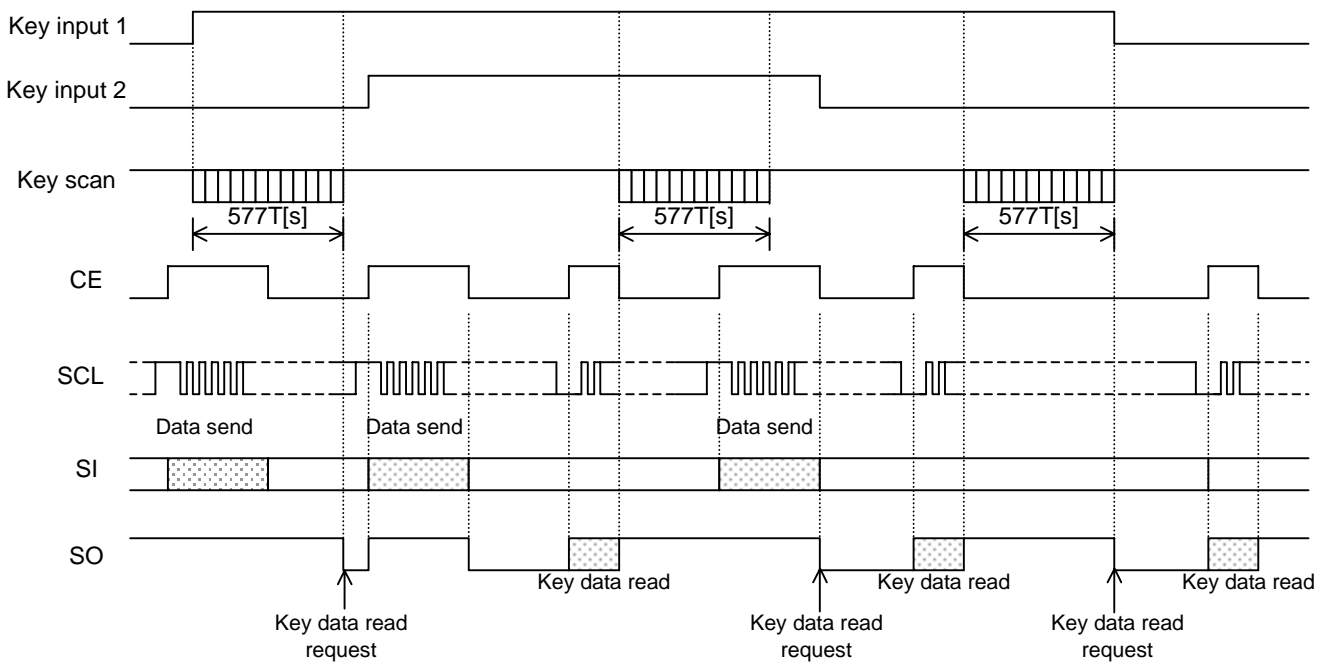

(6-6) Power save mode

Key scan operates with follows in Power save mode.

- 1, Key scan signal output terminals S0 – S5 output “H”, “L” signals by the control data S0 and S1 when key scan does not operate (refer the detail of instructions), and output key scan signals after start of key scan operation. The conditions of key scan signal input terminals K0 – K4 are “L” state with internal pull-down resistances, though “H” signal comes in to K0 – K4 corresponding to the turned on keys.
- 2, The oscillation circuit function of key scan starts twice operations when any keys on cross points with S0– S5 terminals line and K0 – Ki turned on. It stops when a couple of data by continuously twice key scan operations are accorded and fixed as a correct key status. It operates more 2 times when the key status is not fixed and any keys are still turning on. It repeats again and again until key status is fixed. The correct key status data is stored and newly key scan operation does not start until external CPU reads data out after key status is fixed.
- 3, When the key status is fixed, SO terminal outputs “L” signal as Key data read out request to CPU. CPU should read key data out at detection of this “L” signal. If CPU writes the display data or instructions to the **NJU6535** when SO terminal outputs “L” signal, SO terminal outputs “H” level during “CE” terminal is “H”.
- 4, The Key data read out request signal is released and SO terminal outputs “H” signal after finish of CPU key data read out for newly key scan operation. Although Power save mode is not released.

SO terminal requires pull up resistor (1Kohm to 10Kohms) because of Open drain type output. Multiple data of key are output in case of key more input so that CPU should process the data by itself.

Key scan example (Power save mode)

Ex.) PS0= "0", PS1= "1" (K4="H" power save)

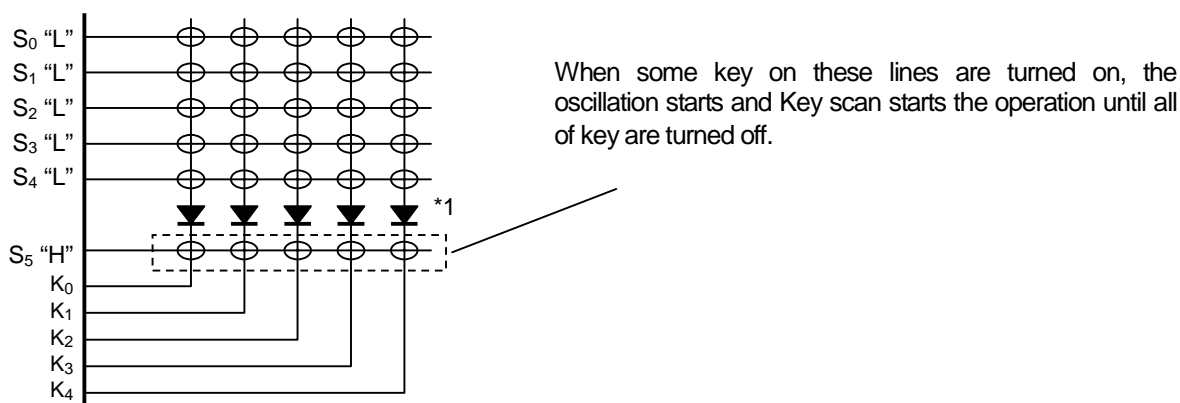

*1 These diodes are required to recognize key more input of keys on the K4 line when only K4 terminal outputs “H” signal in power save mode as shown above example. In case of no diodes, incorrect key data may read out sometimes by key more input of keys on lines of K0 to K4.

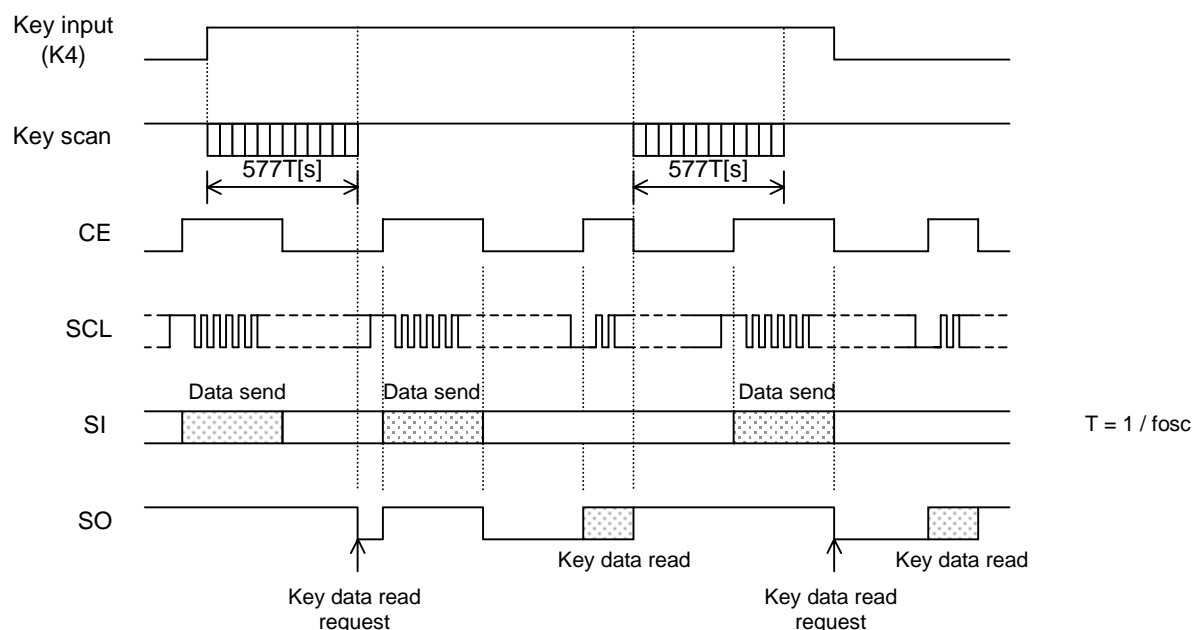

(6-7) Key More Input

Key scan signal output terminal S0 to S5 output "H" level in state of Key More Input. Although Key state is detected without diodes to prevent unexpected key scan signal flow, non-pressed key data may change pressed key data in triple or more key Input as shown in Fig. 1 and incorrect key data may be output to external CPU. For prevention of miss-recognition by incorrect key data, diodes should be inserted in front of K0 – K4 terminals as shown in Fig. 3 or control program of CPU should ignore the combination of key data miss-recognition. For example, 4 keys and more ON data should be ignored.

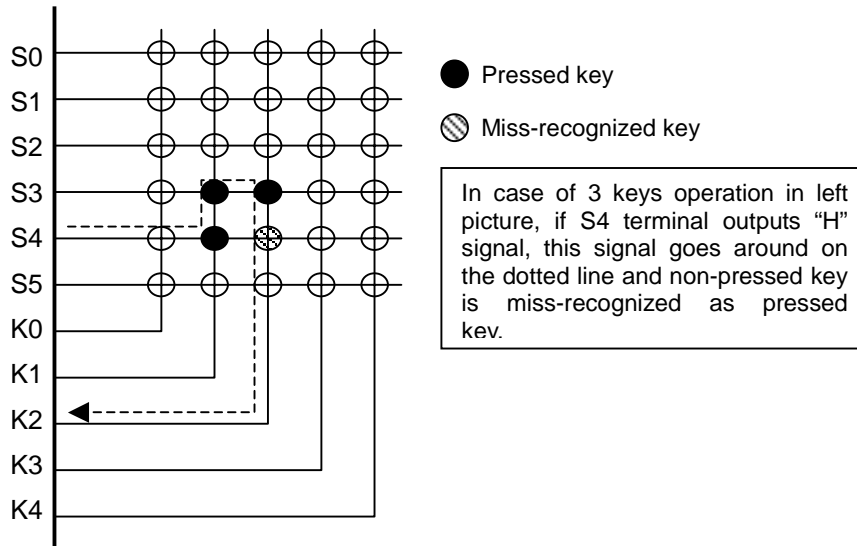

Fig. 1 Miss-recognized example by key more input

In modes of power save 1 (S0=0, S1=1 / Keys on only S5 line are valid) or power save 2 (S0=0, S1=1 / Keys on only S4 and S5 lines are valid), pay attention about the followings. When Key More Input is operated across the valid line and invalid, non-pressed key is miss-recognized as pressed key. However, Key data on the invalid line is not read out and 4 keys and more operation in the mean time are not ignored by CPU control program as shown in Fig. 2. In this case, diodes operate to prevent miss-recognition as shown in Fig. 3.

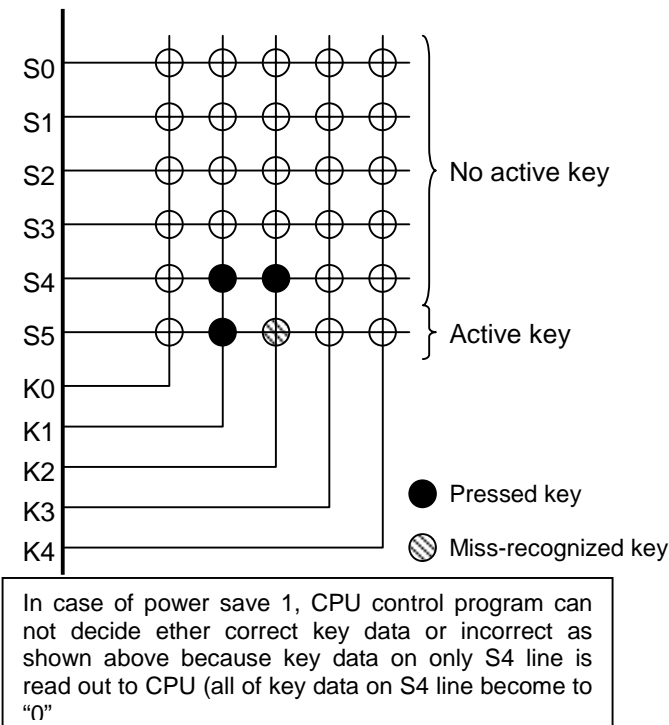

Fig. 2 Miss-recognition in power save 1

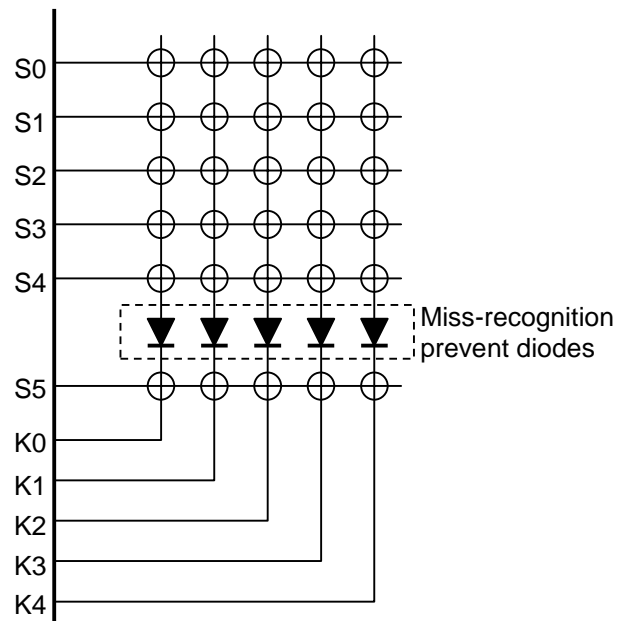

Fig. 3 Connect miss-recognition prevent diodes

(6-8) Key data reading out operation by external CPU

(a) Display data writing

Display data and instruction change operate at the rising edge of signal into CE terminal. Written data or instructions do not operate during CE terminal "H". When the time to write whole display data into Data Buffer becomes too long by huge display data, display may be effected unexpected display. Data writing order from Data 1 to Data 3 in 1/3 duty or Data 1 to Data 4 in 1/4 duty is not limited.

The duty is 1/3 after initialization. For 1/4 duty operation, Data 1 must be written first after initialization

(b) Key data reading out operation

The minimum period from Key in to SO terminal = "L" is $577T(t_1)$ by key scan operation. When key scan operation performs again for key data fix preventing from noise or bouncing of key, the period from Key in to SO terminal = "L" is $1200T(t_1)$. When the SO terminal outputs "L", the key scan operation is stopped after execution of key data reading out operation. Therefore, fixed key data is kept until end of key data reading out operation. When key data reading out operation is performed during SO terminal = "H", both of key data from KD1 to KD30 and power save flag (PSF) are not outputted correctly.

Key data reading out operation example

The flowchart below shows an example of timer interrupt application. When SO terminal condition is "L" after check of SO terminal condition at every timer interrupt operation, it is decided as Key In and key data reading out operation is performed. When SO terminal condition is "H", it is decided as Key Off. For the correct decision of Key Off, the timer interrupt cycle ($1/t_3$) should be expanded over the time added with [period of key scan ($1200T$ in case of measure against key bouncing of key) and [period of key data reading out operation (t_2)]. In this time, the period of timer interrupt cycle (t_3) must be set with enough margin including the range of fosc.

● Sequence of key data reading out operation

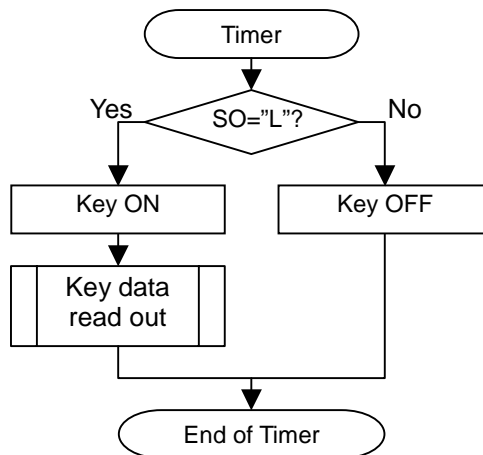

● Timing chart of key data reading out operation

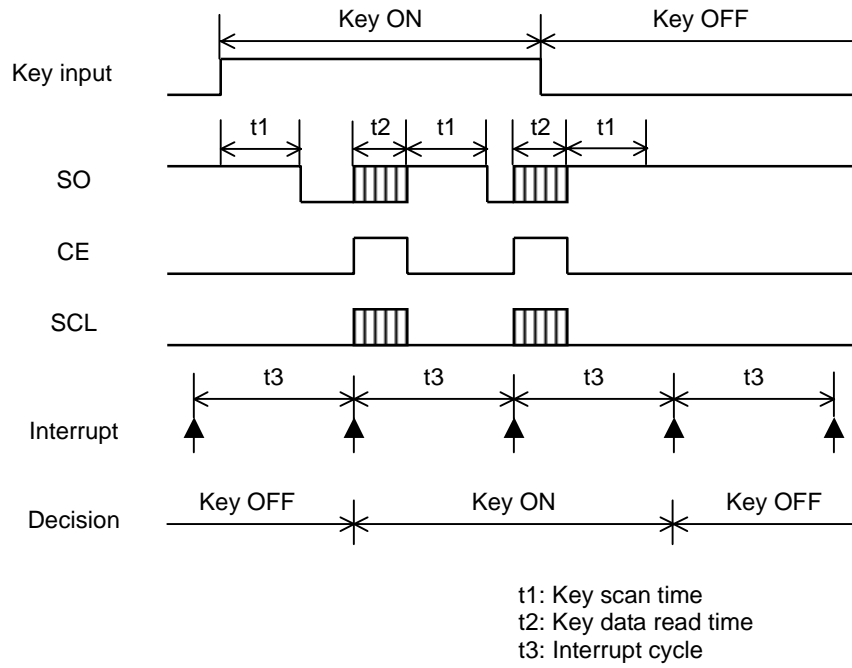

*: $t_3 > t_1 + t_2$

(7) Power on reset circuit initializes

Power on reset circuit initializes the **NJU6535** at Power ON and OFF. It generates reset signal to initialize the system at low VDD less than power down detection voltage (2.5V typical).

(7-1) Initial status in reset

- 1, Stop the oscillation circuit
- 2, Display Off (Available Serial data transmission)
- 3, Disable Key scan function
- 4, Filled "L" data in all of key data buffer

(7-2) The status of output port terminals in power on reset

Output terminals	Reset status
SEG ₁ /P ₀ to SEG ₄ /P ₃	L *1
SEG ₅ to SEG ₃₉	L
SEG ₄₀ /COM ₄	L *1
COM ₁ to COM ₃	L
S ₀ /SEG ₄₁ , S ₁ /SEG ₄₂	L *1
S ₂ to S ₄	X *2
S ₅	H
SO	H *3

*1 This terminal operates as segment driver and outputs "L".

*2 This terminal is not fixed the function in/after power on reset until PS0 and PS1 of control data are transmitted.

*3 This terminal consisted of Open-drain output type circuit requires external pull-up resistor (1K ohm to 10k) connect ting to external power source for CPU. If key data read is executed in power on reset, the read data is fixed as "H".

(7-3) Power on reset operation

When the voltage rising time of power source is over than 1mS, the generated signal of VDET initializes the system of **NJU6535** as reset. When the voltage falling time of power source is over than 1mS, the system is also reset. This status of reset is released automatically at the falling signal of CE terminal after completed serial data transmission (Display data D1 to D126 and control data at 1/3 duty, Display data D1 to D164 and control data at 1/4 duty).

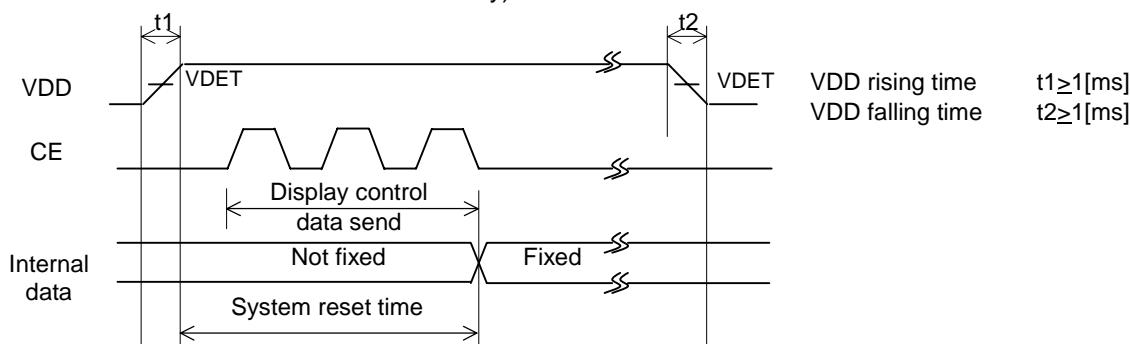

When these voltage rising or falling time of power source are not over than 1ms, the Initialization operation as reset does not operate correctly.

(8) LCD panel drive

(8-1) LCD driving voltage generation circuit

LCD driving voltage generation circuit generates LCD driving bias voltages V0, V1 and V2. It adjusts the voltage by 8 steps electrical volume from VDD and allots the voltage to V0, V1 and V2 by resistor-voltage-dividing as shown in below.

VDD, V0, V1 and V2 terminals requires external capacitors for bias voltage stabilization for display quality. These values of capacitors should be fixed in accordance with evaluation in the application.

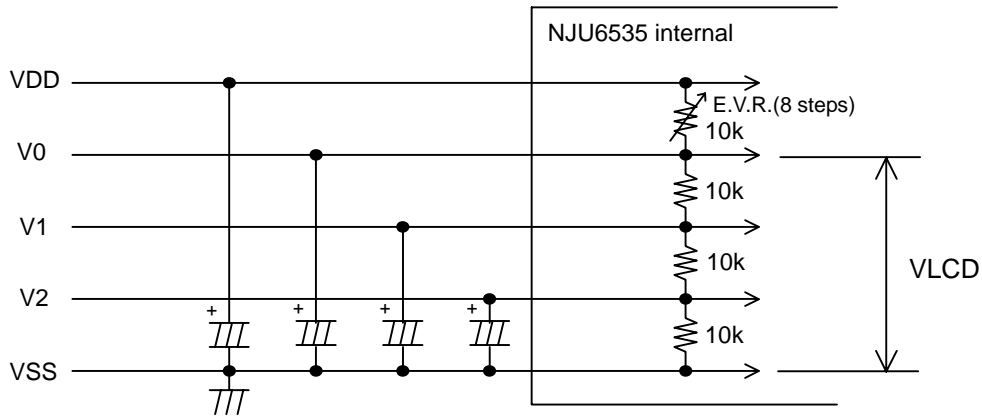

When the E.V.R. is not used, V0 terminal should connect to VDD.

When the **NJU6535** operates as 1/2 bias operation, V1 terminal should connect to V2.

■ ABSOLUTE MAXIMUM RATINGS

Ta=25°C

PARAMETER	SYMBOL	CONDITION	RATINGS	UNIT
Supply Voltage	VDDmax	VDD terminal, Ta=25°C	-0.3 to +6.0	V
Input Voltage	VI	OSC, K ₀ to K ₄ , V ₀ to V ₂ , CE, SCL, SI terminal, Ta=25°C	-0.3 to VDD+0.3	V
Output Voltage	VO	SO, OSC, SEG ₁ to SEG ₄₂ , COM ₁ to COM ₄ , S ₀ to S ₅ , P ₀ to P ₃ , Ta=25°C	-0.3 to VDD+0.3	V
Power Dissipation	Pdmax	Ta=85°C	300	mW
Storage Temperature	Tstg	-	-55 to +125	°C
Operating temperature	Topr	-	-40 to +85	°C

Note1) All voltage values are specified as Vss = 0V.

Note2) If the LSI are used on condition beyond the absolute maximum rating, the LSI may be destroyed. Using LSI within electrical characteristics is strongly recommended for normal operation. Use beyond the electric characteristics conditions will cause malfunction and poor reliability.

Note3) Decoupling capacitor should be connected between VDD and Vss due to the stabilized operation for the voltage converter.

■ ELECTRICAL CHARACTERISTICS

DC Characteristics

VDD=5V±10%, Ta= - 40 to 85°C

PARAMETER	SYMBOL	CONDITION	MIN	TYP	MAX	UNIT
Power supply	VDD		4.5	5.0	5.5	V
"H" level input voltage(1)	VIH(1)	K ₀ to K ₄	0.6VDD		VDD	V
"H" level input voltage(2)	VIH(2)	SCL, SI, CE	0.8VDD		VDD	V
"L" level input voltage(1)	VIL(1)	K ₀ to K ₄ , SCL, SI, CE	0		0.2VDD	V
Hysteresis voltage	VH	SCL, SI, CE	0.3	0.25VDD		V
"H" level input current	I IH	SCL, SI, CE VI = VDD			5.0	uA
"L" level input current	I IL	SCL, SI, K ₀ to K ₄ , CE VI = 0V	-5.0			uA
Pull-down resistance	R _{PD}	K ₀ to K ₄ VDD=5.0V	50	100	250	kΩ
"H" level output voltage(1)	VOH(1)	S ₀ to S ₅ I _o = -500uA	VDD-1.2	VDD-0.5	VDD-0.2	V
"H" level output voltage(2)	VOH(2)	P ₁ to P ₄ I _o = -10mA	VDD-1.0			V
"H" level output voltage(3)	VOH(3)	SEG ₁ to SEG ₄₂ I _o = -20uA	V ₀ -1.0			V
"H" level output voltage(4)	VOH(4)	COM ₁ to COM ₄ I _o = -100uA	V ₀ -1.0			V
"L" level output voltage(1)	VOL(1)	S ₀ to S ₅ I _o = 25uA	0.2	0.5	1.5	V
"L" level output voltage(2)	VOL(2)	P ₁ to P ₄ I _o = 10mA			1.0	V
"L" level output voltage(3)	VOL(3)	SEG ₁ to SEG ₄₂ I _o = 20uA			1.0	V
"L" level output voltage(4)	VOL(4)	COM ₁ to COM ₄ I _o = 100uA			1.0	V
"L" level output voltage(5)	VOL(5)	SO I _o = 1mA		0.1	0.5	V
COM 1/2 level voltage	VMC ¹ / ₂	COM ₁ to COM ₄ I _o = ±100uA	1/2V ₀ -1.0		1/2V ₀ +1.0	V
COM 1/3 level voltage	VMC ¹ / ₃	COM ₁ to COM ₄ I _o = ±100uA	1/3V ₀ -1.0		1/3V ₀ +1.0	V
COM 2/3 level voltage	VMC ² / ₃	COM ₁ to COM ₄ I _o = ±100uA	2/3V ₀ -1.0		2/3V ₀ +1.0	V
SEG 1/3 level voltage	VMS ¹ / ₃	SEG ₁ to SEG ₄₂ I _o = ±20uA	1/3V ₀ -1.0		1/3V ₀ +1.0	V
SEG 2/3 level voltage	VMS ² / ₃	SEG ₁ to SEG ₄₂ I _o = ±20uA	2/3V ₀ -1.0		2/3V ₀ +1.0	V
Oscillator Frequency	f _{osc}	Ta=25°C	25	38	51	KHz
Bleeder Resistance	R _B	Between V ₀ -VSS, Ta=25°C		30		kΩ
E.V.R. Resistance	R _{EVR}	Between VDD-V ₀ , Ta=25°C		10		kΩ
Power down detect voltage	VDET		1.7	2.5	3.3	V
Operating Current	IDD1	Power save mode			100	uA
	IDD2	VDD=5.5V, 1/2 Bias, Output terminal open		250	500	uA
	IDD3	VDD=5.5V, 1/3 Bias, Output terminal open		200	400	uA

AC Characteristics

VDD=5V±10%, Ta= - 40 to 85°C

PARAMETER	SYMBOL	CONDITION	MIN	TYP	MAX	UNIT
"L" level clock pulse width	tWCLL	SCL	160			ns
"H" level clock pulse width	tWCLH	SCL	160			ns
Data setup time	tDS	SCL, SI / SO	160			ns
Data hold time	tDH	SCL, SI / SO	160			ns
CE wait time	tCP	CE, SCL	160			ns
CE setup time	tCS	CE, SCL	160			ns
CE hold time	tCH	CE, SCL	160			ns
CE "L" level width	tWCL	CE	160			ns
SO output delay time	tDC	SO, Rpu=4.7 kΩ, CL=10pF			1.5	ms
SO rise time	tDR	SO, Rpu=4.7kΩ, CL=10pF			1.5	ms
SCL rise time	tr				160	ns
SCL fall time	tf				160	ns

SO terminal is Open-Drain type output, so that the characteristics of SO terminal are changed by values of pull-up resistance Rpu and CL.

(1) Write operation

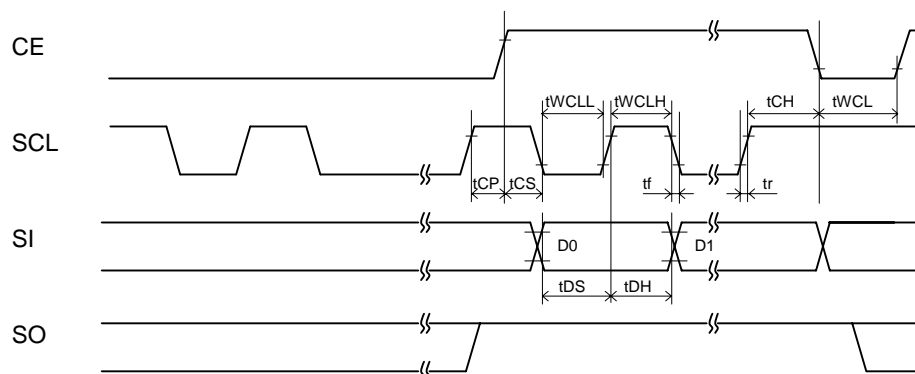

(2) Key data read operation

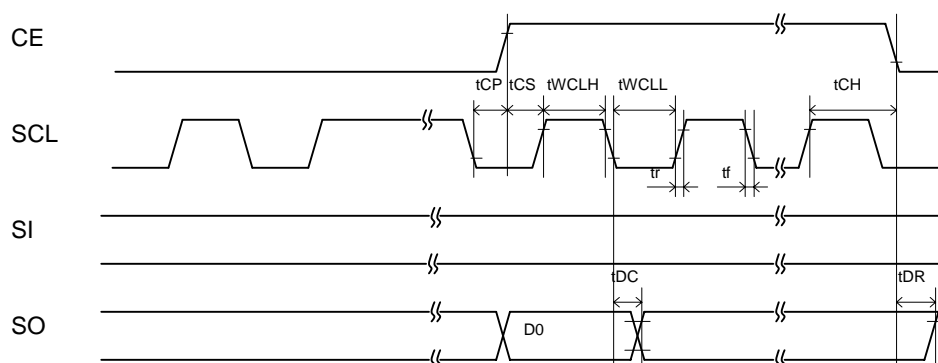

■ LCD DRIVING WAVEFORM

(1) 1/3 Duty, 1/2 Bias Driving

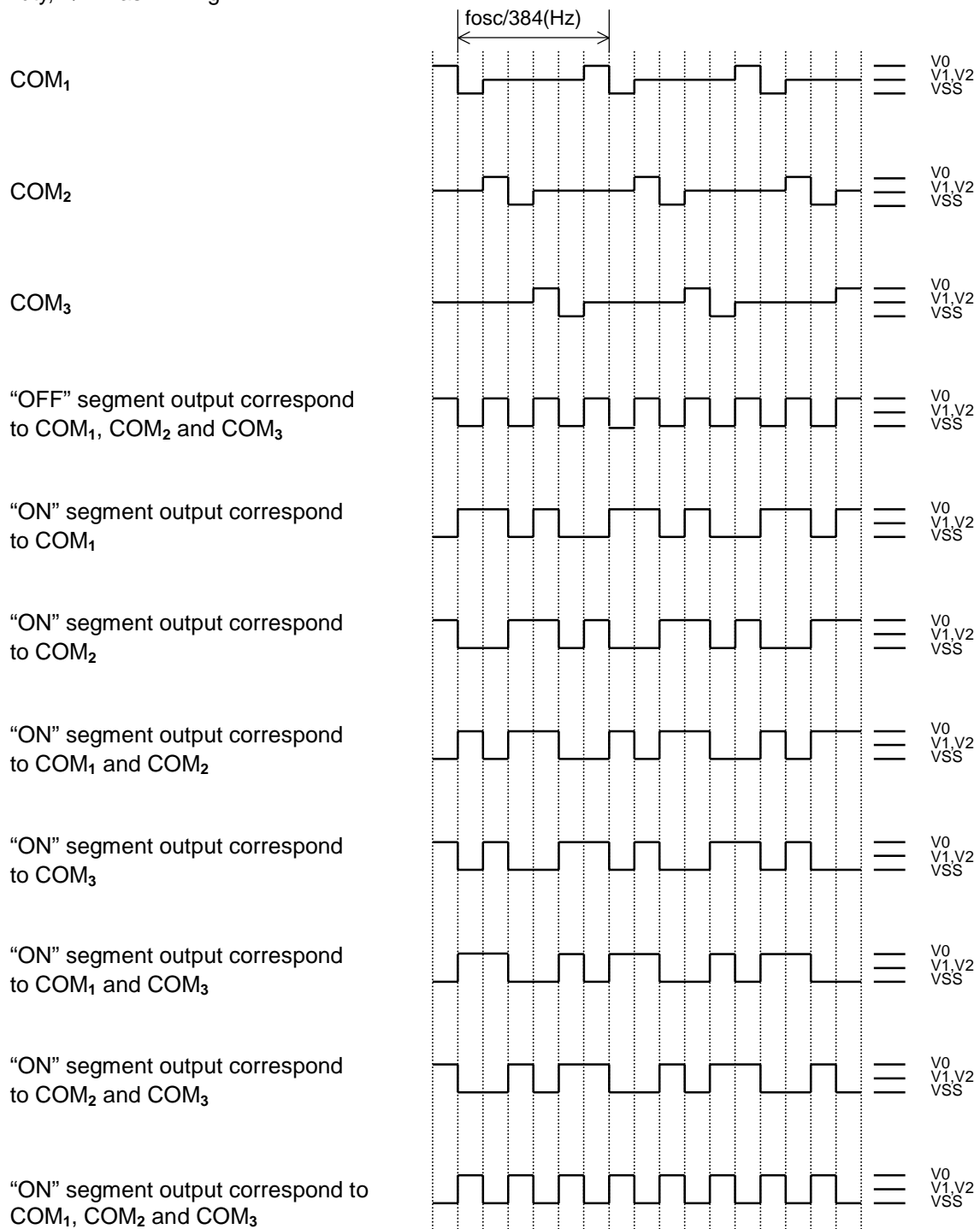

(2) 1/3 Duty, 1/3 Bias Driving

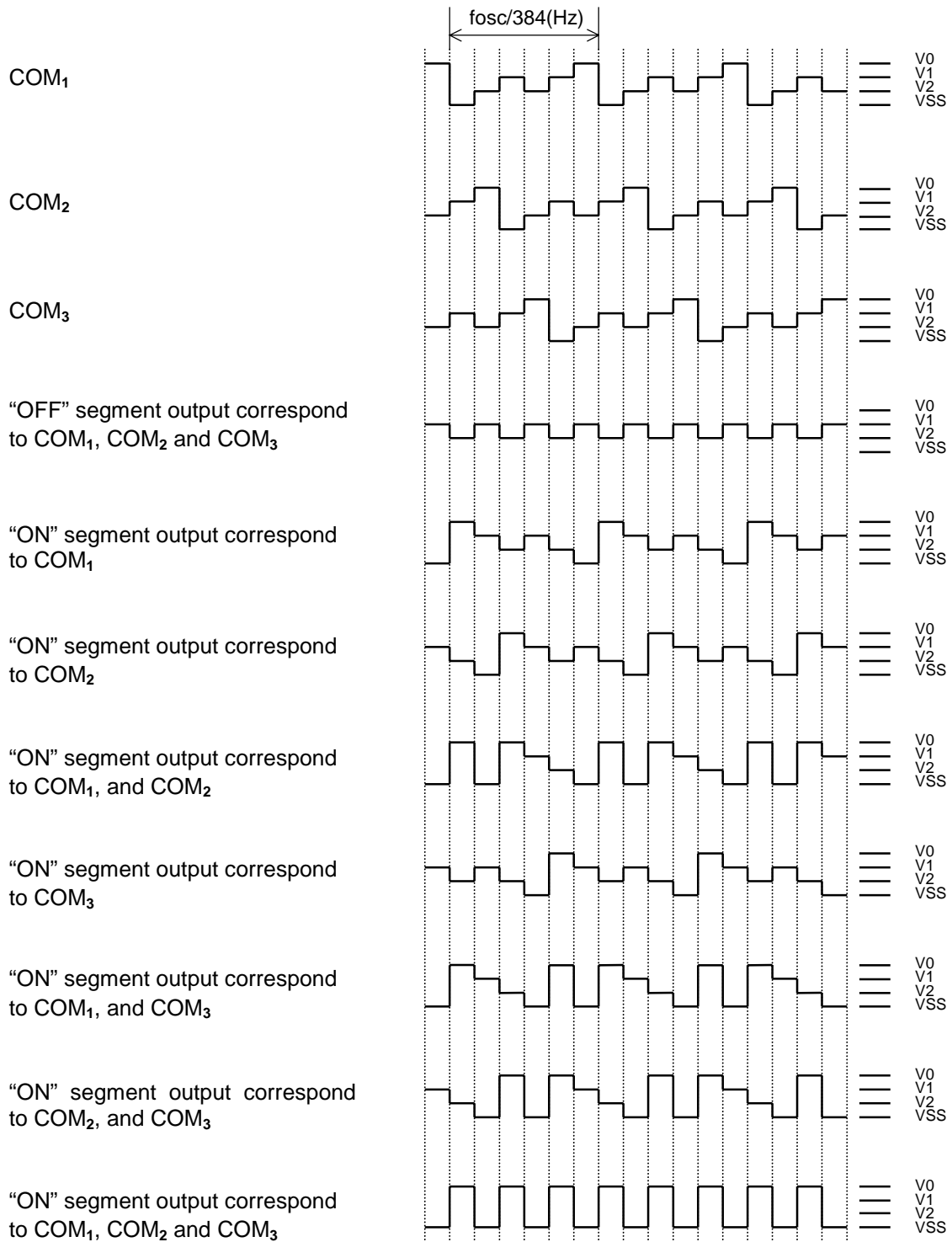

(3) 1/4 Duty, 1/2 Bias Driving

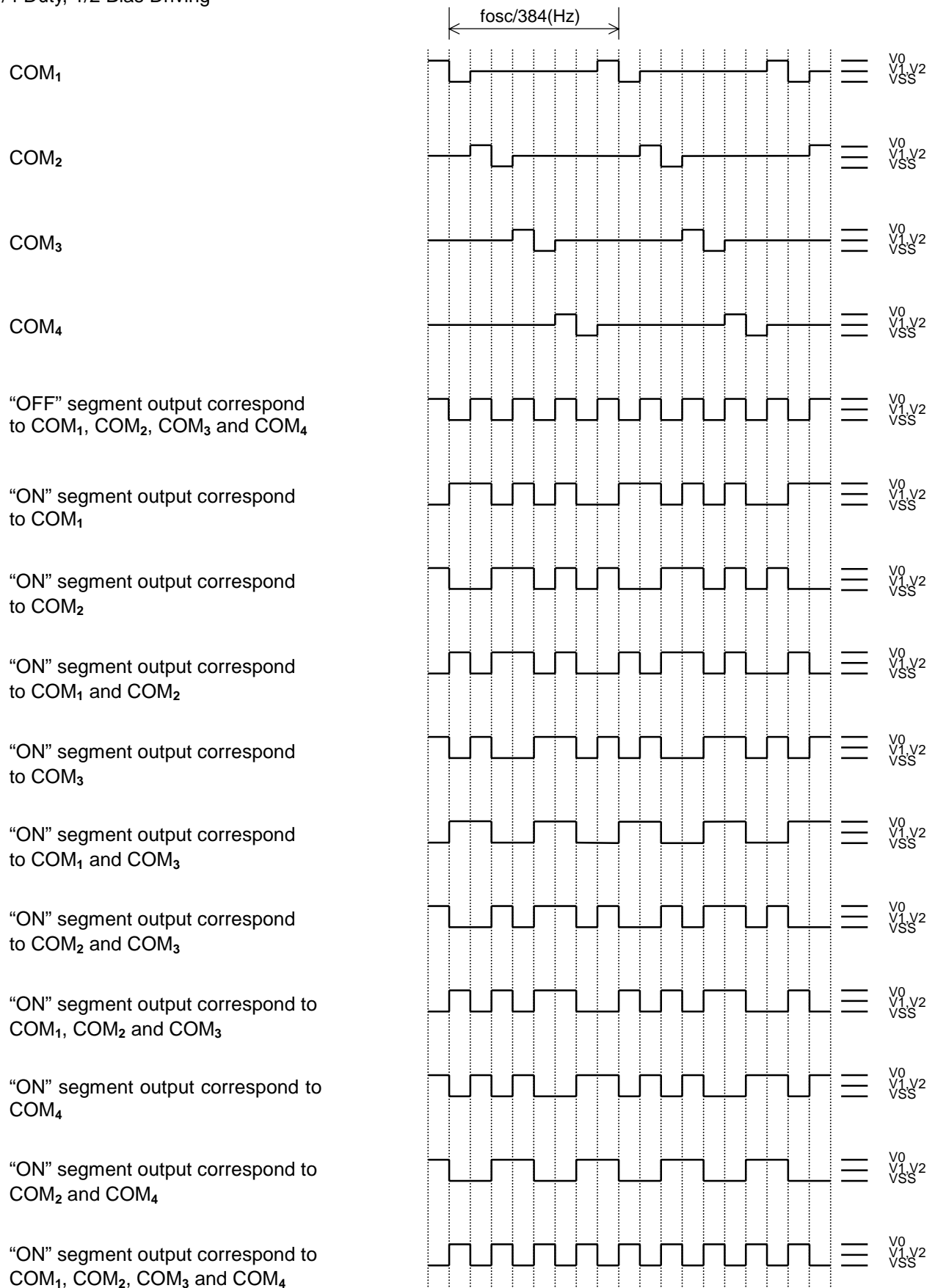

(4) 1/4 Duty, 1/3 Bias Driving

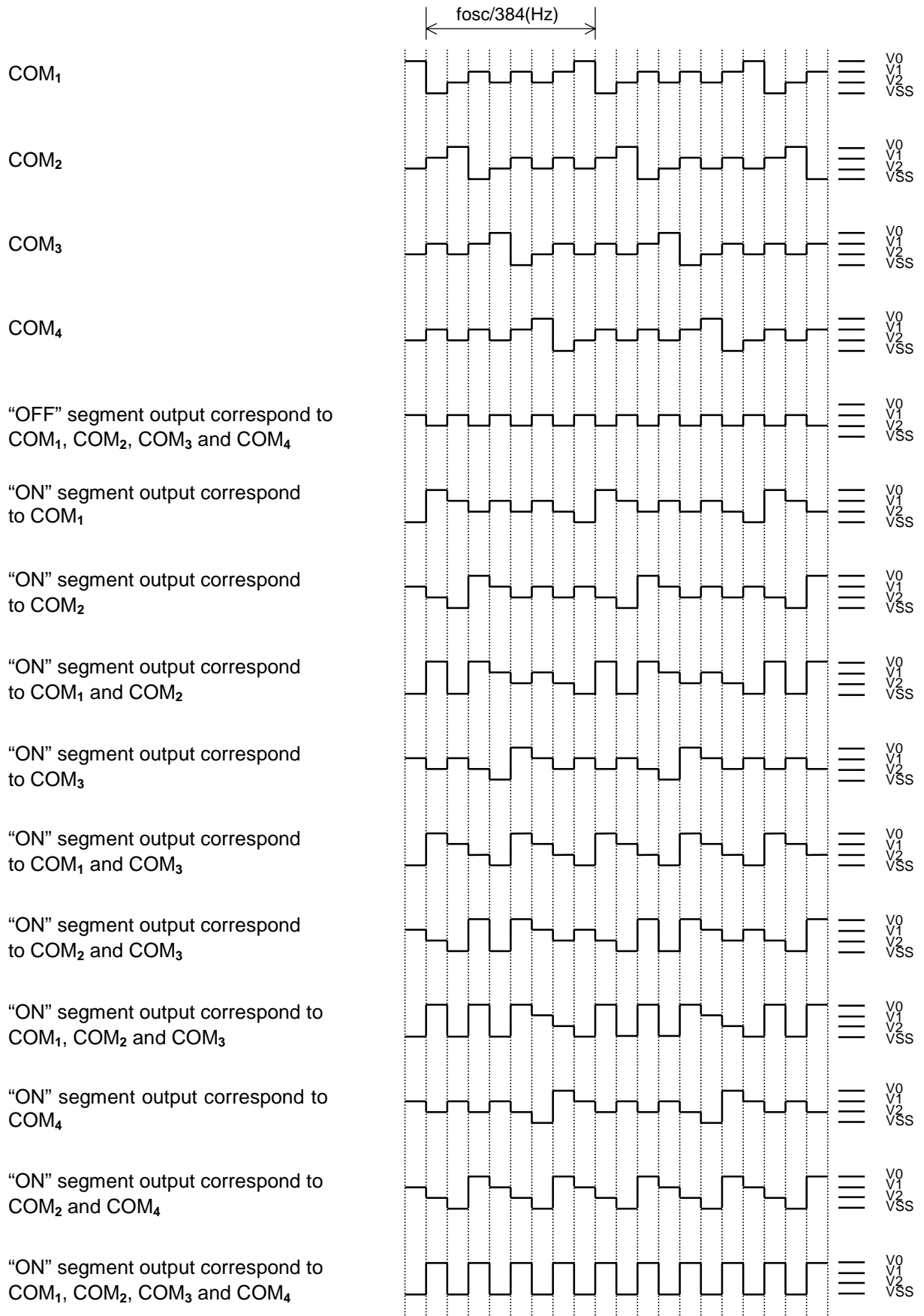

NJU6535

APPLICATION CIRCUIT

(1) 1/3 Duty, 1/2 Bias Driving (Not use E.V.R.)

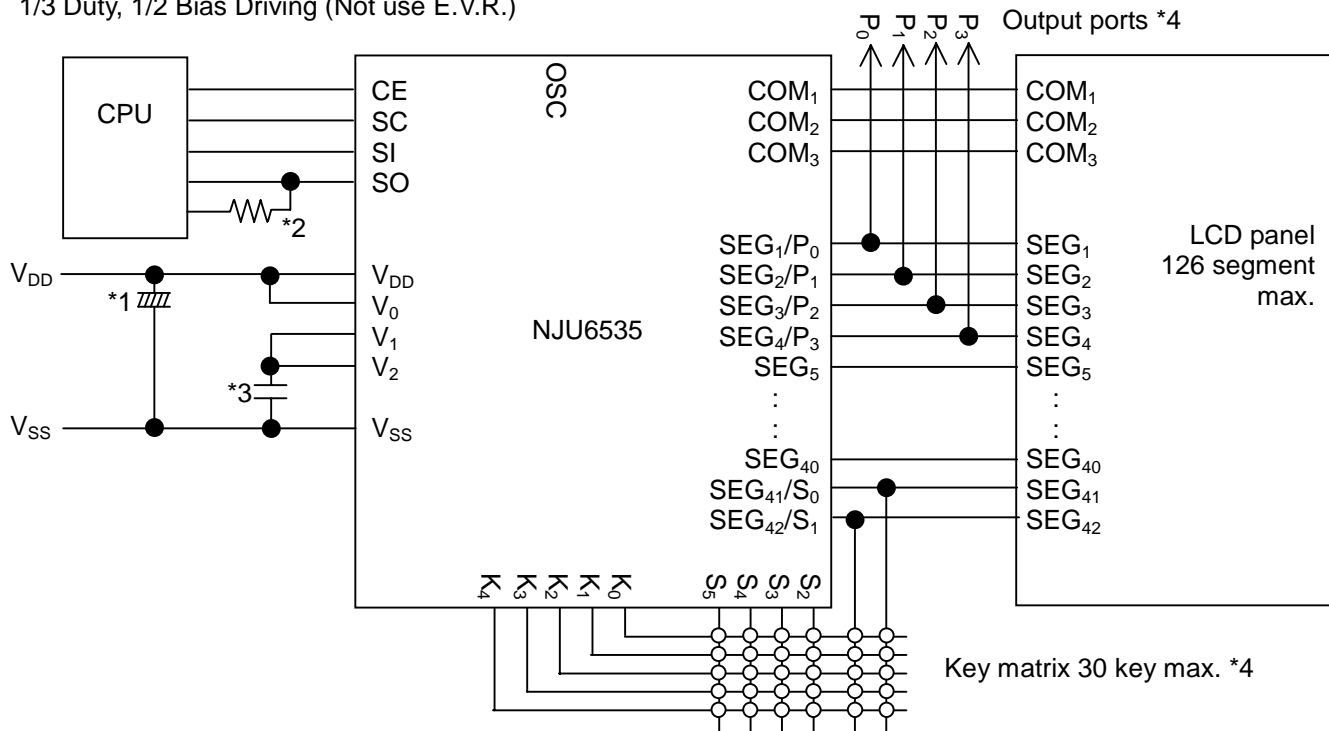

- *1 The rising time of Power source voltage at Power on and the falling time at Power off must keep over than 1 mS because of Voltage detection type Reset circuit operation.
- *2 SO terminal requires external pull-up resistor connecting to Power source of external CPU because of Open-drain type output.
- *3 This capacitor for bias voltage stabilization should be connected in accordance with display quality in application.
- *4 General output ports and Key scan signal output terminals are duplicated-function terminals with Segment outputs. A function must be selected either Segment output or other.

(2) 1/3 Duty, 1/3 Bias Driving (E.V.R. use)

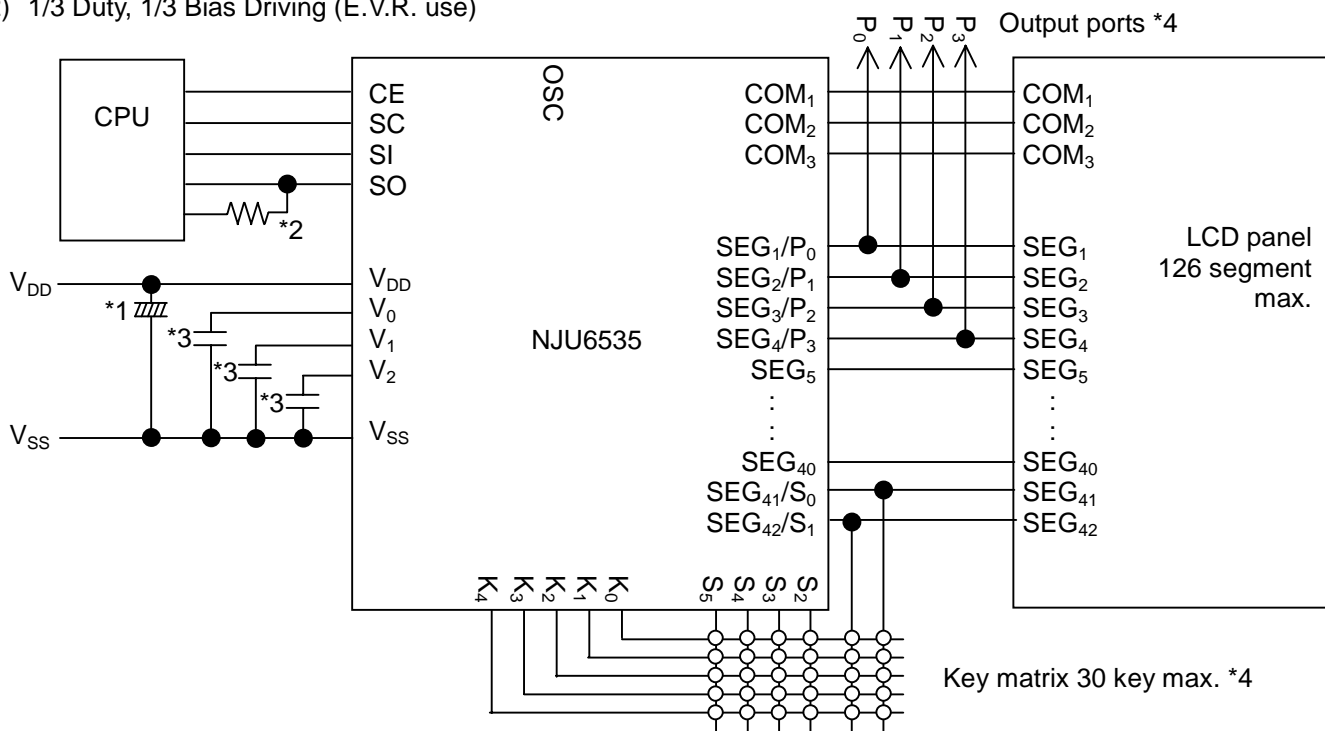

- *1 The rising time of Power source voltage at Power on and the falling time at Power off must keep over than 1 mS because of Voltage detection type Reset circuit operation.
- *2 SO terminal requires external pull-up resistor connecting to Power source of external CPU because of Open-drain type output.
- *3 This capacitor for bias voltage stabilization should be connected in accordance with display quality in application.
- *4 General output ports and Key scan signal output terminals are duplicated-function terminals with Segment outputs. A function must be selected either Segment output or other.

(3) 1/4 Duty, 1/3 Bias Driving (E.V.R. use)

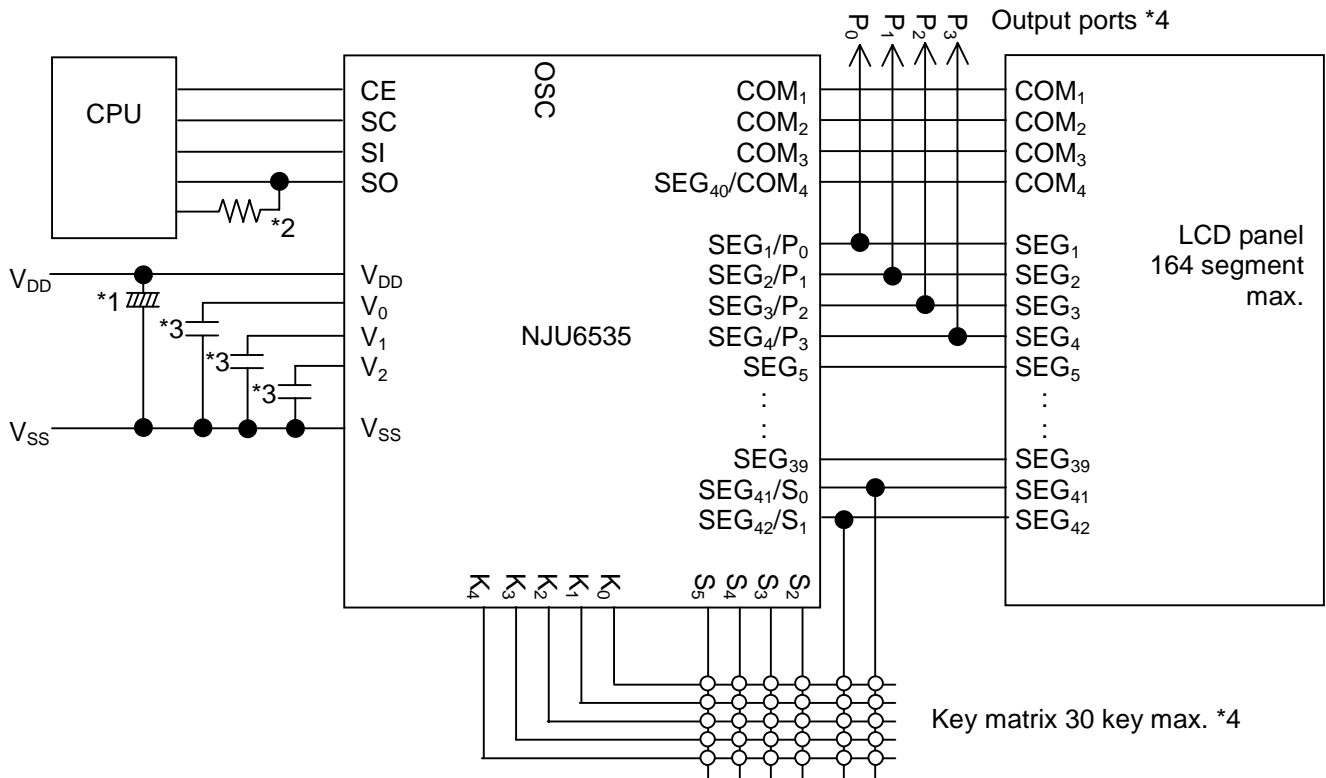

- *1 The rising time of Power source voltage at Power on and the falling time at Power off must keep over than 1 mS because of Voltage detection type Reset circuit operation.
- *2 SO terminal requires external pull-up resistor connecting to Power source of external CPU because of Open-drain type output.
- *3 This capacitor for bias voltage stabilization should be connected in accordance with display quality in application.
- *4 General output ports and Key scan signal output terminals are duplicated-function terminals with Segment outputs. A function must be selected either Segment output or other.

MEMO

[CAUTION]

The specifications on this databook are only given for information, without any guarantee as regards either mistakes or omissions. The application circuits in this databook are described only to show representative usages of the product and not intended for the guarantee or permission of any right including the industrial rights.

Данный компонент на территории Российской Федерации

Вы можете приобрести в компании MosChip.

Для оперативного оформления запроса Вам необходимо перейти по данной ссылке:

<http://moschip.ru/get-element>

Вы можете разместить у нас заказ для любого Вашего проекта, будь то серийное производство или разработка единичного прибора.

В нашем ассортименте представлены ведущие мировые производители активных и пассивных электронных компонентов.

Нашей специализацией является поставка электронной компонентной базы двойного назначения, продукции таких производителей как XILINX, Intel (ex.ALTERA), Vicor, Microchip, Texas Instruments, Analog Devices, Mini-Circuits, Amphenol, Glenair.

Сотрудничество с глобальными дистрибьюторами электронных компонентов, предоставляет возможность заказывать и получать с международных складов практически любой перечень компонентов в оптимальные для Вас сроки.

На всех этапах разработки и производства наши партнеры могут получить квалифицированную поддержку опытных инженеров.

Система менеджмента качества компании отвечает требованиям в соответствии с ГОСТ Р ИСО 9001, ГОСТ РВ 0015-002 и ЭС РД 009

Офис по работе с юридическими лицами:

105318, г.Москва, ул.Щербаковская д.3, офис 1107, 1118, ДЦ «Щербаковский»

Телефон: +7 495 668-12-70 (многоканальный)

Факс: +7 495 668-12-70 (доб.304)

E-mail: info@moschip.ru

Skype отдела продаж:

moschip.ru

moschip.ru_4

moschip.ru_6

moschip.ru_9