

1769205x2, 176881212, 176861512

**MagI<sup>3</sup>C Power Module**  
**FISM – Fixed Isolated SMT Module**



3.3V – 12V / 1W / 2kV functional isolated  
 unregulated 5V / 12V / 15V Output

**DESCRIPTION**

The FISM series of the unregulated MagI<sup>3</sup>C power module family is a functional isolated, fully integrated DC/DC converter. The module integrates the switching power stage, control circuitry, transformer and capacitors, all in one package.

The module requires no external components for operation thus reducing design effort and complexity to a minimum.

The FISM ensures fast time to market and low development costs.

The FISM series achieves typically an efficiency of 73% to 76%.

The SMT package (12.75x11.1x6.95mm) with industrial standard SMT-8 pinout allows for easy assembly.

**FEATURES**

- 2kV DC functional isolation
- Current capability up to 0.2A
- Nominal input voltage rails: 3.3V / 5V / 12V
- Output voltage: 5V / 12V / 15V unregulated
- No minimum load required
- Continuous output power: 1W
- Integrated C<sub>IN</sub>, C<sub>OUT</sub> and transformer
- Low output voltage ripple: typ. 65mV to 75mV at full load
- Output voltage accuracy: ±5% max.
- Operating frequency range: 50 kHz to 110 kHz
- Operating ambient temperature range: - 40°C to 100°C
- RoHS & REACh compliant
- UL94V-0 package material
- Complies with EN55032 class B conducted and radiated emissions standard
- UL60950-1, 2<sup>nd</sup> Edition
- C22.2 No. 60950-1-07 2<sup>nd</sup> Edition

**TYPICAL APPLICATIONS**

- Data acquisition
- Test and measurement systems
- Interface and microcontroller supply
- Industrial control

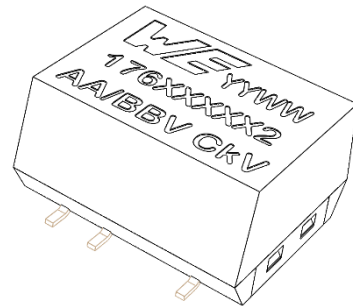

**TYPICAL CIRCUIT DIAGRAM**

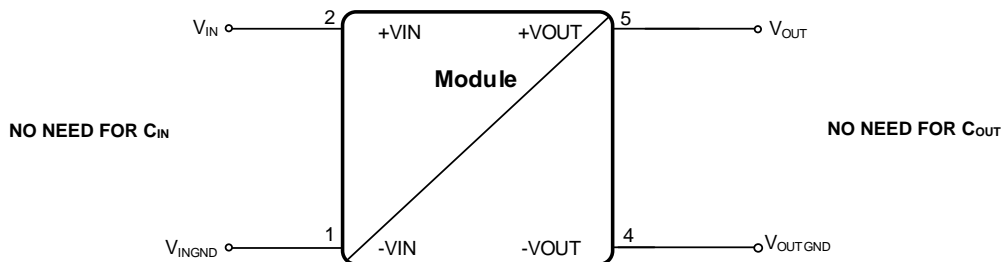

1769205x2, 176881212, 176861512

**MagI<sup>3</sup>C** Power Module  
**FISM – Fixed Isolated SMT Module**



**MARKING DESCRIPTION**

MARKING	DESCRIPTION
WE	Würth Elektronik tradename
YY	Year
WW	Calendar week
176xxxxx2	Ordering code
AA	Input voltage
BB	Output voltage
C	Isolation voltage

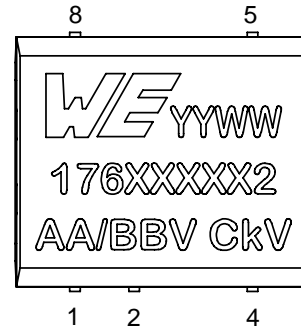

**PIN DESCRIPTION**

SYMBOL	NUMBER	TYPE	DESCRIPTION
- VIN	1	Power	Input ground
+ VIN	2	Power	Input voltage
-VOUT	4	Power	Output ground
+VOUT	5	Power	Output voltage
N.C.	8	Power	Not connected

**ORDERING INFORMATION**

ORDER CODE	PART DESCRIPTION	SPECIFICATIONS	PACKAGE	PACKAGING UNIT
176920502	WPMIC9200502S	3.3V <sub>IN</sub> / 5V <sub>OUT</sub> version	SMT-8	Tape&Reel 500pcs
176920512	WPMIB9200502S	5V <sub>IN</sub> / 5V <sub>OUT</sub> version	SMT-8	Tape&Reel 500pcs
176920522	WPMIA9200502S	12V <sub>IN</sub> / 5V <sub>OUT</sub> version	SMT-8	Tape&Reel 500pcs
176881212	WPMIB9081202S	5V <sub>IN</sub> / 12V <sub>OUT</sub> version	SMT-8	Tape&Reel 500pcs
176861512	WPMIB9061502S	5V <sub>IN</sub> / 15V <sub>OUT</sub> version	SMT-8	Tape&Reel 500pcs
17800FISM		3.3 to 12V <sub>IN</sub> / 5 to 15V <sub>OUT</sub>	Eval Board	1

**SALES INFORMATION**

SALES CONTACTS
Würth Elektronik eiSos GmbH & Co. KG EMC & Inductive Solutions Max-Eyth-Str. 1 74638 Waldenburg Germany Tel. +49 (0) 7942 945 0 <a href="http://www.we-online.com/powermodules">www.we-online.com/powermodules</a> Technical support: <a href="mailto:powermodules@we-online.com">powermodules@we-online.com</a>

1769205x2, 176881212, 176861512

**MagI<sup>3</sup>C** Power Module  
**FISM – Fixed Isolated SMT Module**



## ABSOLUTE MAXIMUM RATINGS

Caution:

Exceeding the listed absolute maximum ratings may affect the device negatively and may cause permanent damage. These are stress ratings only, which do not imply functional operation of the device at these or any other condition beyond those indicated under "Operation Conditions".

SYMBOL	PARAMETER		LIMITS		UNIT
			MIN <sup>(1)</sup>	MAX <sup>(1)</sup>	
VIN	Input pin voltage for 10s@10% Load	3.3VIN / 5VOUT version, (176920502)	2.64	3.96	V
		5VIN / 5VOUT version, (176920512)	4.00	5.75	V
		12VIN / 5VOUT version, (176920522)	9.60	13.8	V
		5VIN / 12VOUT version, (176881212)	4.00	5.75	V
		5VIN / 15VOUT version, (176861512)	4.00	5.75	V
VOUT	Output pin voltage	3.3VIN / 5VOUT version, (176920502)	0	10	V
		5VIN / 5VOUT version, (176920512)			V
		12VIN / 5VOUT version, (176920522)	0	16	V
		5VIN / 12VOUT version, (176881212)			V
		5VIN / 15VOUT version, (176861512)			0
V <sub>ISO</sub>	Isolation voltage input to output, 100% tested for 1 second <sup>(2)</sup>		-	2000	V
	Isolation voltage input to output 60 seconds <sup>(6)</sup>		-	1600	V
	Continuous <sup>(6)</sup>		-	550	V
T <sub>storage</sub>	Assembled, non-operating storage temperature		-55	125	°C
V <sub>ESD</sub>	ESD Voltage (Human Body Model), according to EN61000-4-2 <sup>(12)</sup>			±2000	V

All parameters are specified after a 15 minutes run-in time unless otherwise noted.

1769205x2, 176881212, 176861512

**MagI<sup>3</sup>C** Power Module  
**FISM** – Fixed Isolated **SMT** Module



## OPERATING CONDITIONS

Operating conditions are conditions under which operation of the device is intended to be functional. All values are referenced to respective GND.

MIN and MAX limits are valid for the recommended ambient temperature range of **-40°C to 100°C**. Typical values represents statistically the utmost probability at following conditions:  $T_A = 25^\circ\text{C}$ ,  $V_{IN}=\text{nominal}$   $V_{OUT}=\text{nominal}$   $I_{OUT}=\text{nominal}$  unless otherwise noted.

SYMBOL	PARAMETER		MIN <sup>(1)</sup>	TYP <sup>(3)</sup>	MAX <sup>(1)</sup>	UNIT
$V_{IN}$	Input voltage	3.3 $V_{IN}$ / 5 $V_{OUT}$ version, (176920502)	2.97	3.3	3.63	V
		5 $V_{IN}$ / 5 $V_{OUT}$ version, (176920512)	4.5	5	5.5	
		5 $V_{IN}$ / 12 $V_{OUT}$ version, (176881212)				
		5 $V_{IN}$ / 15 $V_{OUT}$ version, (176861512)				
		12 $V_{IN}$ / 5 $V_{OUT}$ version, (176920522)	10.8	12	13.2	
$V_{OUT}$	Nominal output voltage	3.3 $V_{IN}$ / 5 $V_{OUT}$ version, $I_{OUT} = 200\text{mA}$ (176920502)	4.75	5	5.25	V
		5 $V_{IN}$ / 5 $V_{OUT}$ version, $I_{OUT} = 200\text{mA}$ (176920512)				
		12 $V_{IN}$ / 5 $V_{OUT}$ version, $I_{OUT} = 200\text{mA}$ (176920522)				
		5 $V_{IN}$ / 12 $V_{OUT}$ version, $I_{OUT} = 84\text{mA}$ (176881212)	11.40	12	12.60	
		5 $V_{IN}$ / 15 $V_{OUT}$ version, $I_{OUT} = 66\text{mA}$ (176861512)	14.25	15	15.75	
$I_{OUT}$	Nominal output current <sup>(4)</sup>	3.3 $V_{IN}$ / 5 $V_{OUT}$ version, (176920502)	0	-	200	mA
		5 $V_{IN}$ / 5 $V_{OUT}$ version, (176920512)				
		12 $V_{IN}$ / 5 $V_{OUT}$ version, (176920522)				
		5 $V_{IN}$ / 12 $V_{OUT}$ version, (176881212)	0	-	84	
		5 $V_{IN}$ / 15 $V_{OUT}$ version, (176861512)	0	-	66	
$P_{OUT}$	Nominal output power	176xxxxx2	-	-	1	W

1769205x2, 176881212, 176861512

**MagI<sup>3</sup>C** Power Module  
**FISM – Fixed Isolated SMT Module**



SYMBOL	PARAMETER	MIN <sup>(1)</sup>	TYP <sup>(3)</sup>	MAX <sup>(1)</sup>	UNIT
C <sub>OUT MAX</sub>	3.3V <sub>IN</sub> / 5V <sub>OUT</sub> version, I <sub>OUT</sub> = 200mA (176920502)	-	-	1000	μF
	5V <sub>IN</sub> / 5V <sub>OUT</sub> version, I <sub>OUT</sub> = 200mA (176920512)				
	12V <sub>IN</sub> / 5V <sub>OUT</sub> version, I <sub>OUT</sub> = 200mA (176920522)				
	5V <sub>IN</sub> / 12V <sub>OUT</sub> version, I <sub>OUT</sub> = 84mA (176881212)	-	-	330	
	5V <sub>IN</sub> / 15V <sub>OUT</sub> version, I <sub>OUT</sub> = 66mA (176861512)	-	-	220	
T <sub>A</sub>	Ambient temperature range	-40	-	100	°C

All parameters are specified after a 15 minutes run-in time unless otherwise noted.

#### THERMAL SPECIFICATIONS

SYMBOL	PARAMETER	TYP <sup>(3)</sup>	UNIT
T <sub>case max</sub>	Maximum Case Temperature (top side)	110	°C

#### PACKAGE SPECIFICATIONS

ITEM	PARAMETER	TYP <sup>(2)</sup>	UNIT
Case	UL94V-0 (Refer to UL approval E150608)	-	-
φ (RH)	Operating humidity	5 - 95	%
Weight		1.0	g
IP	Degree of protection according to IEC/EN 60529.	X0	
Vibration	MIL-STD-202G: 5g's for 1 minute, 120 cycles each of 3 orientation, test from 10Hz-55Hz		

1769205x2, 176881212, 176861512

**Magl<sup>3</sup>C** Power Module  
**FISM – Fixed Isolated SMT Module**



## ELECTRICAL SPECIFICATIONS

MIN and MAX limits are valid for the recommended ambient temperature range of **-40°C to 100°C**. Typical values represents statistically the utmost probability at following conditions:  $T_A = 25^\circ\text{C}$ ,  $V_{IN}=\text{nominal}$   $V_{OUT}=\text{nominal}$   $I_{OUT}=\text{nominal}$  unless otherwise noted.

SYMBOL	PARAMETER	TEST CONDITIONS	MIN <sup>(1)</sup>	TYP <sup>(3)</sup>	MAX <sup>(1)</sup>	UNIT
<b>Output Current</b>						
$I_{MOC}$	Maximum Overload Current	$V_{OUT}=5\text{V}$ (1769205X2) for 5s	-	-	300 <sup>(7)</sup>	mA
		$V_{OUT}=12\text{V}$ (176881212) for 5s	-	-	126 <sup>(7)</sup>	
		$V_{OUT}=15\text{V}$ (176861512) for 5s	-	-	99 <sup>(7)</sup>	
$I_{CL}$	Output current limit threshold		-	-	No <sup>(8)</sup>	mA
<b>Deviation</b>						
$V_{OUT}$	Line regulation	per 1.0% change in input voltage <sup>(9)</sup>	-	$\pm 1.2$	-	%
	Load regulation	10% to 100% load current, 5V <sub>out</sub> – see <a href="#">OUTPUT VOLTAGE TOLERANCE ENVELOPE</a>	-	-	-1 +15	%
	Output Voltage Accuracy	$V_{in}$ nominal @ $I_{out}$ nominal	-	-2%	$\pm 5$	%
	Output voltage ripple 5V <sub>OUT</sub>	20MHz BW, without external capacitor	-	65	-	mV <sub>pp</sub>
	Output voltage ripple 12/15V <sub>OUT</sub>	20MHz BW, without external capacitor	-	75	-	mV <sub>pp</sub>
<b>Switching frequency</b>						
$f_{sw}$	Switching frequency	$V_{IN} = 3.3\text{V}$ , $V_{OUT} = 5\text{V}$ , $I_{OUT} = 200\text{mA}$ (176920502)	50	-	110	kHz
		$V_{IN} = 5\text{V}$ , $V_{OUT} = 5\text{V}$ , $I_{OUT} = 200\text{mA}$ (176920512)				
		$V_{IN} = 12\text{V}$ , $V_{OUT} = 5\text{V}$ , $I_{OUT} = 200\text{mA}$ (176920522)				
		$V_{IN} = 5\text{V}$ , $V_{OUT} = 12\text{V}$ , $I_{OUT} = 84\text{mA}$ (176881212)				
		$V_{IN} = 5\text{V}$ , $V_{OUT} = 15\text{V}$ , $I_{OUT} = 66\text{mA}$ (176861512)				
<b>Input current</b>						
$I_{IN}$	No load input current (operating, switching)	$V_{IN} = 3.3\text{V}$ , $V_{OUT} = 5\text{V}$ , $I_{OUT} = 0\text{mA}$ (176920502)	-	55	-	mA
		$V_{IN} = 5\text{V}$ , $V_{OUT} = 5\text{V}$ , $I_{OUT} = 0\text{mA}$ (176920512)	-	33	-	
		$V_{IN} = 12\text{V}$ , $V_{OUT} = 5\text{V}$ , $I_{OUT} = 0\text{mA}$ (176920522)	-	12	-	
		$V_{IN} = 5\text{V}$ , $V_{OUT} = 12\text{V}$ , $I_{OUT} = 0\text{mA}$ (176881212)	-	33	-	
		$V_{IN} = 5\text{V}$ , $V_{OUT} = 15\text{V}$ , $I_{OUT} = 0\text{mA}$ (176861512)	-	33	-	

1769205x2, 176881212, 176861512

**MagI<sup>3</sup>C** Power Module  
**FISM** – Fixed Isolated **SMT** Module



SYMBOL	PARAMETER	TEST CONDITIONS	MIN <sup>(1)</sup>	TYP <sup>(3)</sup>	MAX <sup>(1)</sup>	UNIT
I <sub>RRC</sub>	Reflected Ripple Current <sup>(10)</sup>	V <sub>IN</sub> = 3.3V, V <sub>OUT</sub> = 5V, I <sub>OUT</sub> = 200mA (176920502)	-	75	-	mA <sub>pp</sub>
		V <sub>IN</sub> = 5V, V <sub>OUT</sub> = 5V, I <sub>OUT</sub> = 200mA (176920512)	-	120	-	
		V <sub>IN</sub> = 12V, V <sub>OUT</sub> = 5V, I <sub>OUT</sub> = 200mA (176920522)	-	50	-	
		V <sub>IN</sub> = 5V, V <sub>OUT</sub> = 12V, I <sub>OUT</sub> = 84mA (176881212)	-	55	-	
		V <sub>IN</sub> = 5V, V <sub>OUT</sub> = 15V, I <sub>OUT</sub> = 66mA (176861512)	-	65	-	
<b>Efficiency</b>						
η	Efficiency	V <sub>IN</sub> = 3.3V, V <sub>OUT</sub> = 5V, I <sub>OUT</sub> = 200mA (176920502)	-	75	-	%
		V <sub>IN</sub> = 5V, V <sub>OUT</sub> = 5V, I <sub>OUT</sub> = 200mA (176920512)	-	75	-	
		V <sub>IN</sub> = 12V, V <sub>OUT</sub> = 5V, I <sub>OUT</sub> = 200mA (176920522)	-	73	-	
		V <sub>IN</sub> = 5V, V <sub>OUT</sub> = 12V, I <sub>OUT</sub> = 84mA (176881212)	-	76	-	
		V <sub>IN</sub> = 5V, V <sub>OUT</sub> = 15V, I <sub>OUT</sub> = 66mA (176861512)	-	76	-	
<b>Isolation characteristics</b>						
C <sub>ISO</sub>	Isolation capacitance		-	-	75	pF
R <sub>ISO</sub>	Isolation resistance V <sub>ISO</sub> =500V		10	-	-	GΩ

All parameters are specified after a 15 minutes run-in time unless otherwise noted.

## RELIABILITY

SYMBOL	PARAMETER	CONDITIONS	MIN <sup>(1)</sup>	TYP <sup>(3)</sup>	MAX <sup>(1)</sup>	UNIT
MTBF <sup>(11)</sup>	Mean Time Between Failures	+25°C: Ground Benign	3000 x10 <sup>3</sup>			h
		+100°C: Ground Benign	950 x10 <sup>3</sup>			h

## APPROVALS

SYMBOL	STANDARD	DESCRIPTION
	UL60950-1, 2 <sup>nd</sup> Edition, 2007-03-27	Recognized for use as Information Technology Equipment, U.S.A. (UL60950-1) and Canada (C22.2 No. 60950-1) E-File: E487909 Applicable for altitudes up to 2000m

1769205x2, 176881212, 176861512

**MagI<sup>3</sup>C** Power Module  
**FISM** – Fixed Isolated **SMT** Module

**RoHS, REACH**

RoHS Directive		Directive 2011/65/EU of the European Parliament and the Council of June 8th, 2011 on the restriction of the use of certain hazardous substances in electrical and electronic equipment.
REACH Directive		Directive 1907/2006/EU of the European Parliament and the Council of June 1st, 2007 regarding the Registration, Evaluation, Authorisation and Restriction of Chemicals (REACH)

**NOTES**

- (1) Min and Max limits are 100% production tested at 25°C. Limits over the operating temperature range are guaranteed through correlation using Statistical Quality Control (SQC) methods.
- (2) Test voltage as defined by the UL60950-1.
- (3) Typical numbers are valid at 25°C ambient temperature and represent statistically the utmost probability assuming the Gaussian distribution.
- (4) Depending on temperature, see thermal derating diagram ([OUTPUT POWER](#)).
- (5) Measured without heatsink, still air. (0 – 20LFM / 0 – 0.1m/s)  
Test PCB 100mmx160mm horizontal orientation 105um copper on top and bottom
- (6) Not production tested. The insulation equivalence is a rated value and based on indicative nature.
- (7) Overload current, see [IMOC DUTY CYCLE](#) & [IMOC TEMPERATURE DERATING](#)
- (8) The module output is not current limited or short circuit protected. Continuous operation above the nominal output current will damage the device.
- (9) Within the complete  $V_{IN}$  tolerance range.
- (10) Peak-to-peak input ripple current
- (11) MIL-HDBK-217F; GB Ground, Benign: Non mobile, temperature and humidity controlled environments readily accessible to maintenance; includes laboratory instruments and test equipment, medical electronic equipment, business and scientific computer complexes, and missiles and support equipment in ground silos; MTBF value is referring to 176xxxxx2
- (12) The human body model is a 100pF capacitor discharged through a 1.5 kΩ resistor into each pin. Test method is per JESD-22-114.



1769205x2, 176881212, 176861512

**Magl<sup>3</sup>C Power Module**  
**FISM – Fixed Isolated SMT Module**



**INTENDED USE – Typical Application**

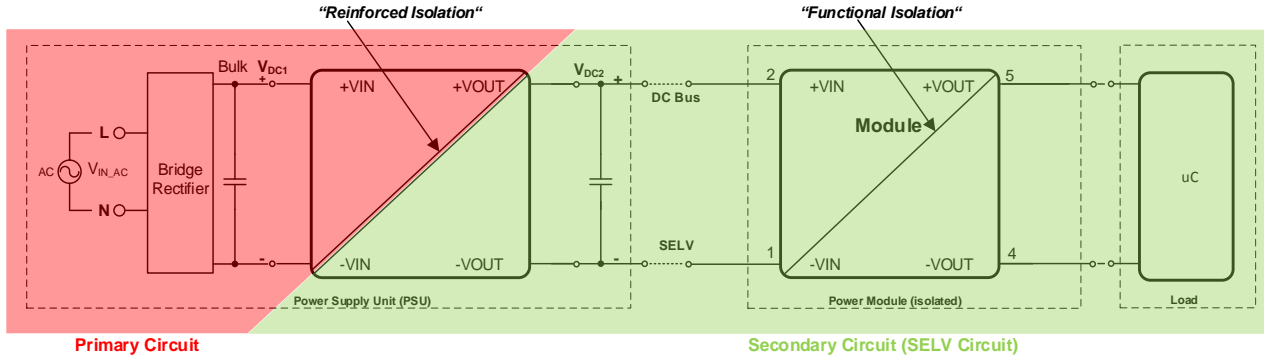

The 176xxxxx2 Magl<sup>3</sup>C power modules are only intended to be used as a CLASS III equipment according to the UL60950-1 standard. That requires that the power module is supplied by a **SELV** (safe extra low voltage) circuit which provides protection against electric shock. There are no HAZARDOUS voltages present in CLASS III Equipment.

A **SELV** circuit is a **secondary circuit** that is designed to be protected from excessive voltages ( $\geq 42$  Vac or  $\geq 60$  Vdc) during normal operating conditions and single fault conditions. A reinforced isolation is required at the boundary between the primary and the secondary circuit.

A circuit which has no direct connection to the primary circuit and derives its power from a transformer, converter or equivalently isolated device, or a battery, is defined as a **secondary circuit**.

In accordance to the safety standard UL60950-1, functional isolation (insulation) is defined as:

*“1.2.9.1 Functional Insulation: insulation that is necessary only for the correct functioning of the equipment  
 NOTE: Functional Insulation by definition does not protect against electric shock. It may, however, reduce the likelihood of ignition and fire.”*

*“1.2.9.5 Reinforced Insulation: single insulation system that provides a degree of protection against electric shock equivalent to Double Insulation under the conditions specified in this standard.  
 NOTE: The Term “insulation system” does not imply that the insulation has to be in one homogeneous piece. It may comprise several layers that cannot be tested as Basic Insulation and Supplementary Insulation*

The above figure shows a typical application of an isolated power module.  $V_{DC1}$  is a hazardous voltage and  $V_{DC2}$  is a SELV voltage.

**ISOLATION VOLTAGE**

To verify the integrity of an isolation a test voltage is applied for a specified time across a component that is designed to provide electrical isolation. This test is known as a ‘Hi Pot Test’, ‘Flash Tested’, ‘Withstand Voltage’, ‘Proof Voltage’, ‘Dielectric Withstand Voltage’ & ‘Isolation Test Voltage’.

All isolated power modules are all 100% production tested at their stated isolation voltage. This is 2kVDC for 1 second.

The isolation test voltage indicated in this datasheet is for voltage transient immunity only. It does not allow this part to be used within a safety isolation system.

The part will function properly with several hundreds of volts applied continuously across the isolation barrier, however surrounding components must be individually analyzed to ensure proper insulation. Isolation measures are taken to prevent any user-accessible circuitry from causing harm.

1769205x2, 176881212, 176861512

**MagI<sup>3</sup>C** Power Module  
**FISM** – Fixed Isolated **SMT** Module



### DIELECTRIC STRENGTH TEST SETUP (HIGH POT TEST)

Connect all input – and output terminals together (see figure below) before connecting the supply voltage. When testing, set the cut-off current to 1mA.

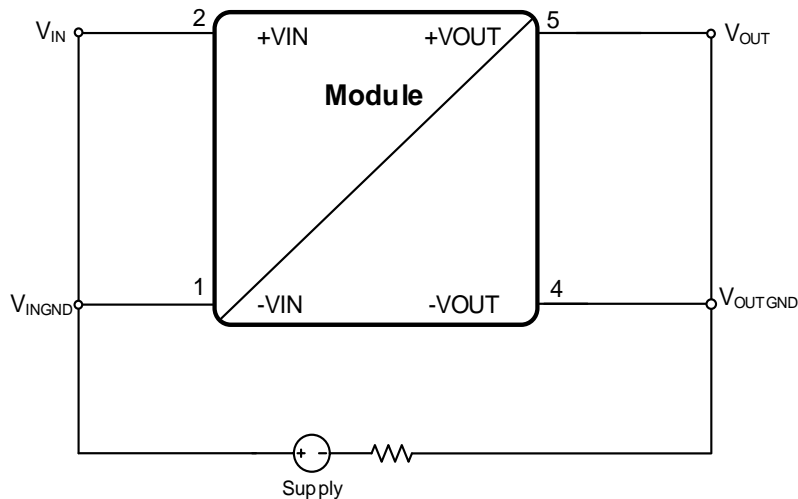

Parameters Supply Device: Current limit set 1mA, Test voltage 2000Vdc, Test time 1sec.

### REPEATED HIGH-VOLTAGE ISOLATION TESTING

A repeated high voltage test of a barrier component will degrade its isolation capabilities.

The primary and secondary windings within this transformer are enameled (coated) but do not possess additional isolation. Typically, parts can withstand many times their stated test voltage and still perform optimally. The magnet wire coating can degrade over time due to chemical reactions that occur at high voltages. We recommend keeping high voltage isolation testing to a minimum to better protect the isolation between the windings. If repeated high voltage isolation testing is required, consider reducing the voltage by a significant amount e.g. 20% from the test voltage stated within the datasheet.

These safety concerns are equally applicable to components that utilize functional isolation beyond wire coating (i.e. physical barriers or spacing).

1769205x2, 176881212, 176861512

**MagI<sup>3</sup>C** Power Module  
**FISM – Fixed Isolated SMT Module**



**TYPICAL PERFORMANCE CURVES**

If not otherwise specified, the following conditions apply:  $T_{AMB} = 25^{\circ}C$ .

**RADIATED AND CONDUCTED EMISSIONS (WITH EMI INPUT FILTER)**

The 176xxxxx2 power module was tested in several EMC configurations to give more realistic information about implementation in the applications. The test setup is based on CISPR16 with the limit values of CISPR32

**FILTER SETUP – MLCC capacitors**

Application specific connection – Using an MLCC based filter

Input cable length of 80cm, the resistive load is connected close to the output of the power module

3.3V → 5V (176920502)

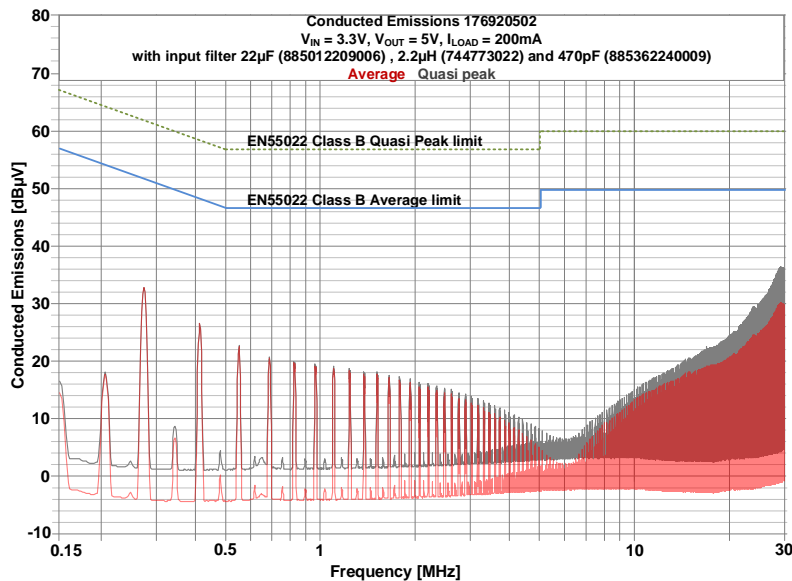
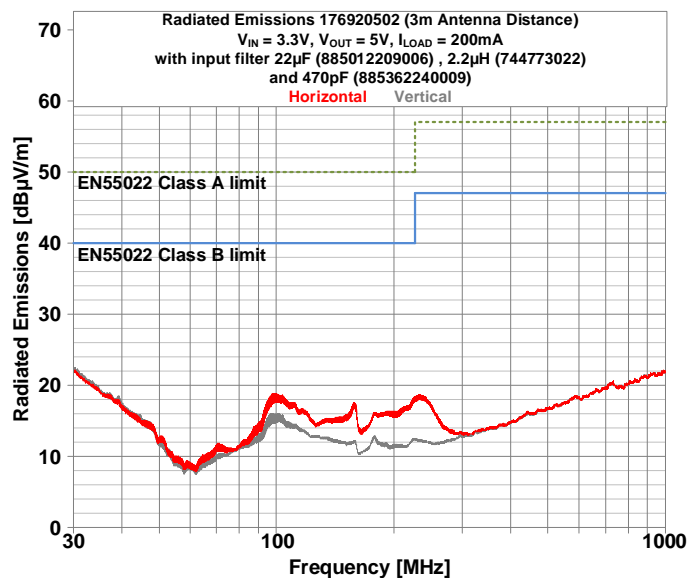

1769205x2, 176881212, 176861512

**Magl<sup>3</sup>C** Power Module  
**FISM – Fixed Isolated SMT Module**



5V → 5V (176920512)

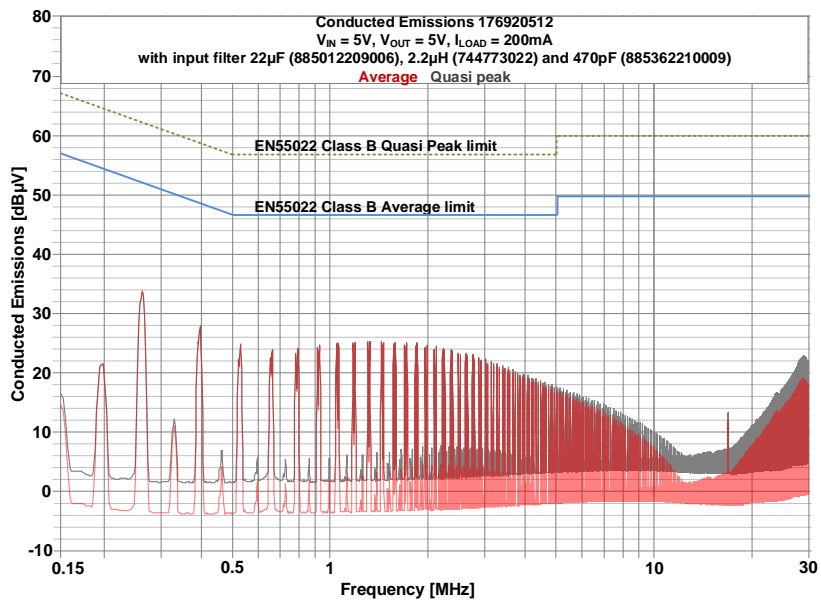
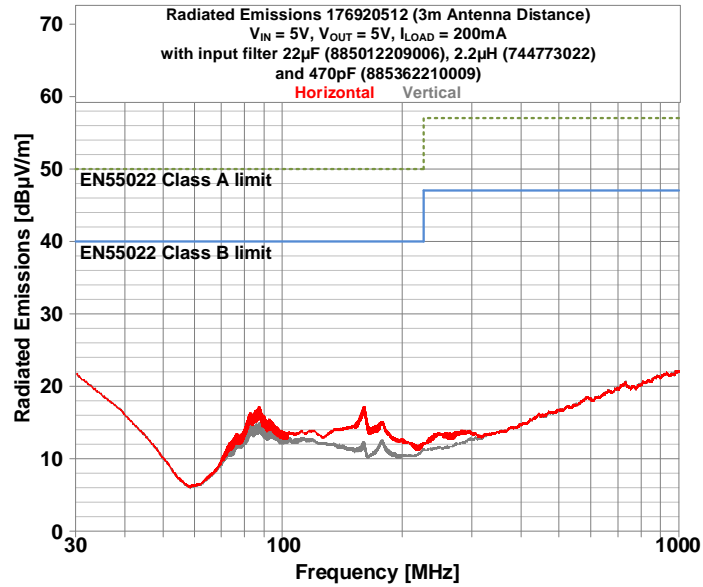

1769205x2, 176881212, 176861512

**MagI<sup>3</sup>C** Power Module  
**FISM – Fixed Isolated SMT Module**



12V → 5V (176920522)

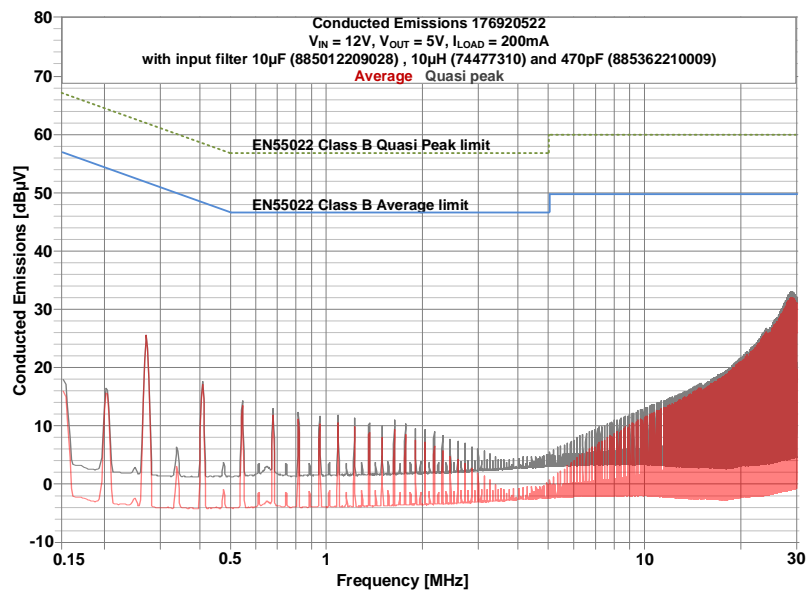
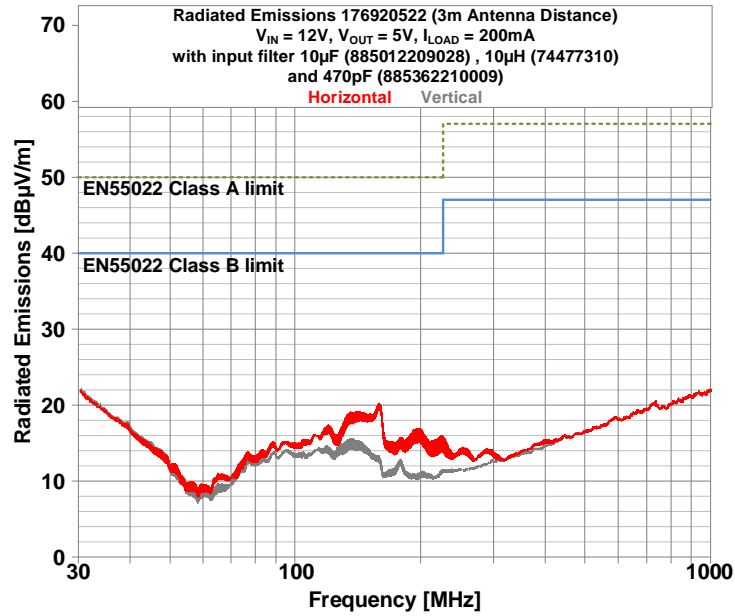

1769205x2, 176881212, 176861512

**MagI<sup>3</sup>C** Power Module  
**FISM – Fixed Isolated SMT Module**



5V → 12V (176881212)

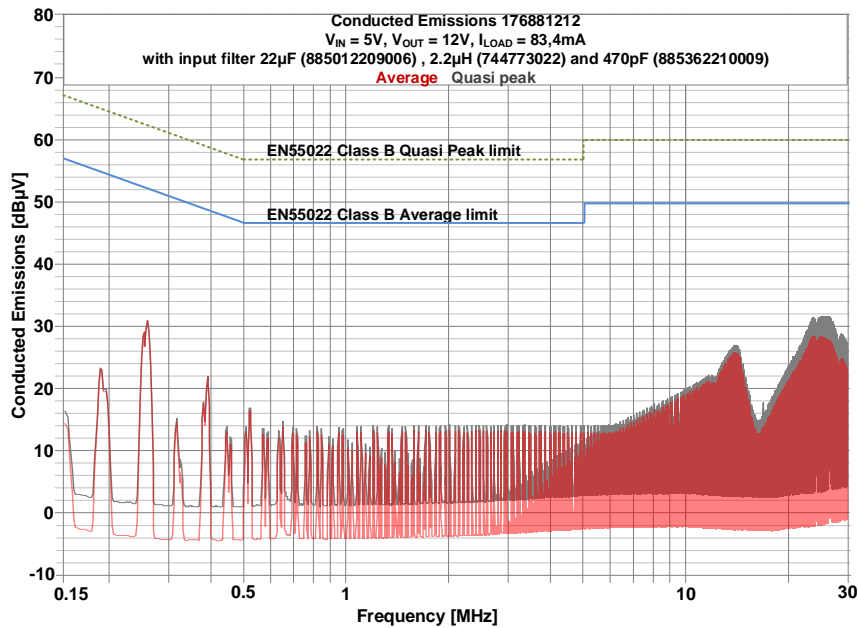
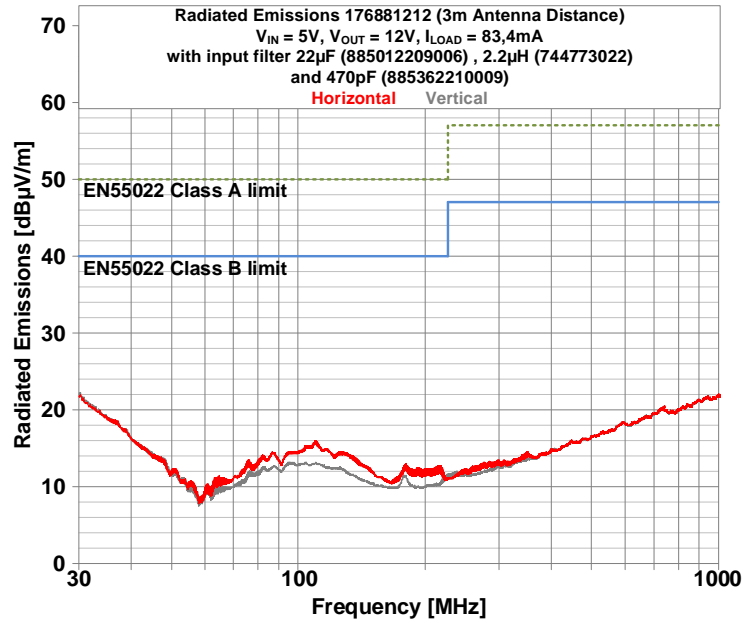

1769205x2, 176881212, 176861512

**Magl<sup>3</sup>C** Power Module  
**FISM – Fixed Isolated SMT Module**



5V → 15V (176861512)

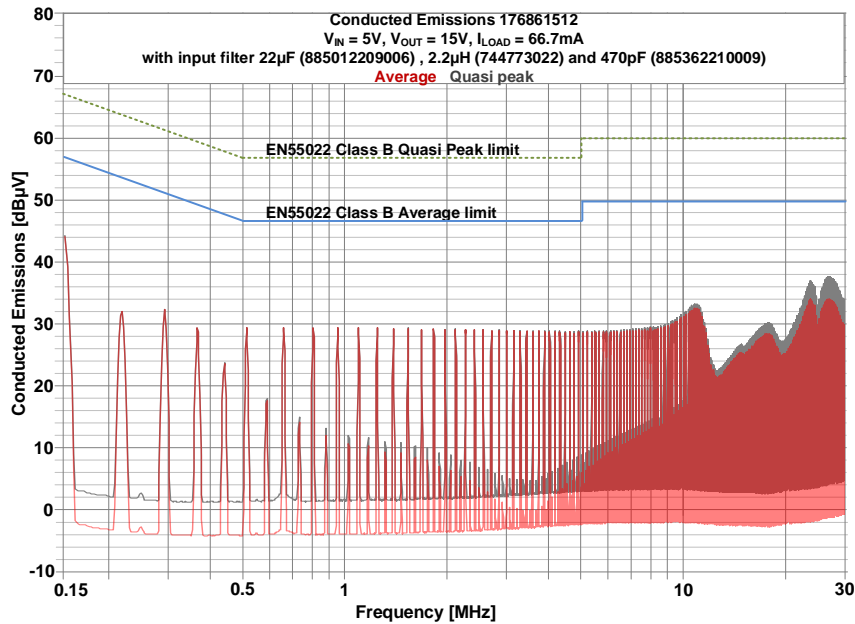
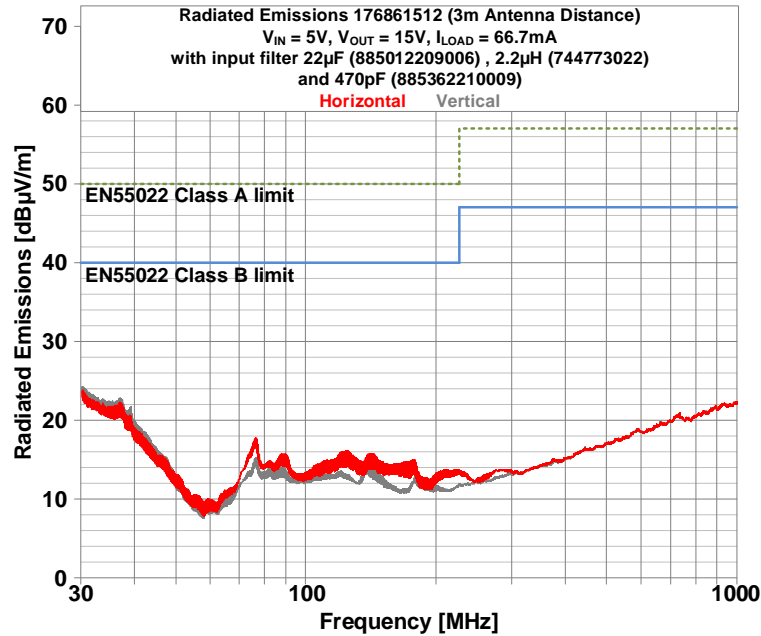

1769205x2, 176881212, 176861512

**MagI<sup>3</sup>C** Power Module  
**FISM – Fixed Isolated SMT Module**



**EFFICIENCY**

176920502 Efficiency -  $V_{IN} = 3.3V$ ,  $T_A = 25^\circ C$

—  $V_{OUT} = 5V$

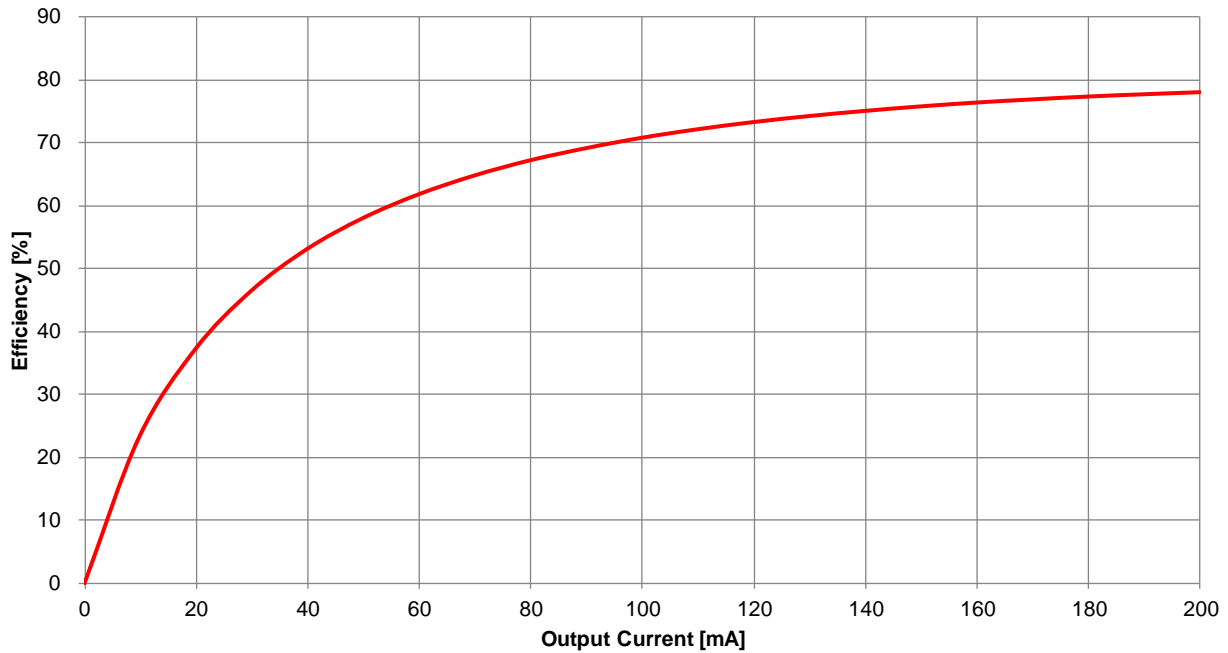

176920512 Efficiency -  $V_{IN} = 5V$ ,  $T_A = 25^\circ C$

—  $V_{OUT} = 5V$

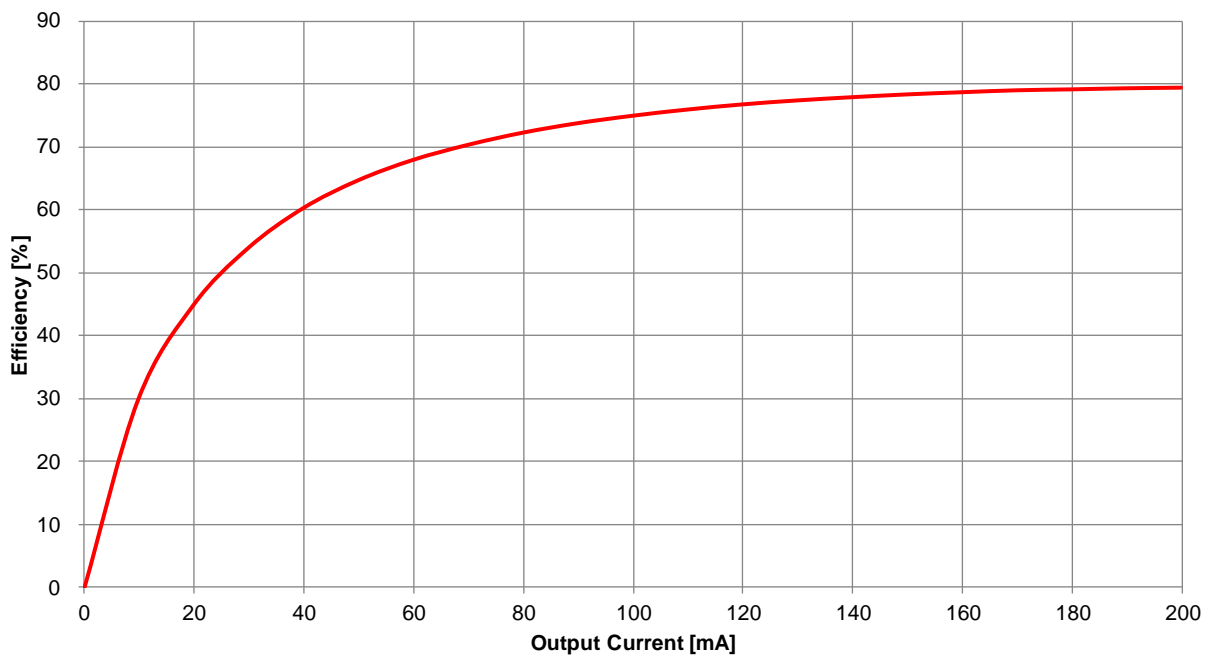



1769205x2, 176881212, 176861512

**MagI<sup>3</sup>C** Power Module  
**FISM – Fixed Isolated SMT Module**



176881212 Efficiency -  $V_{IN} = 5V$ ,  $T_A = 25^\circ C$

—  $V_{OUT} = 12V$

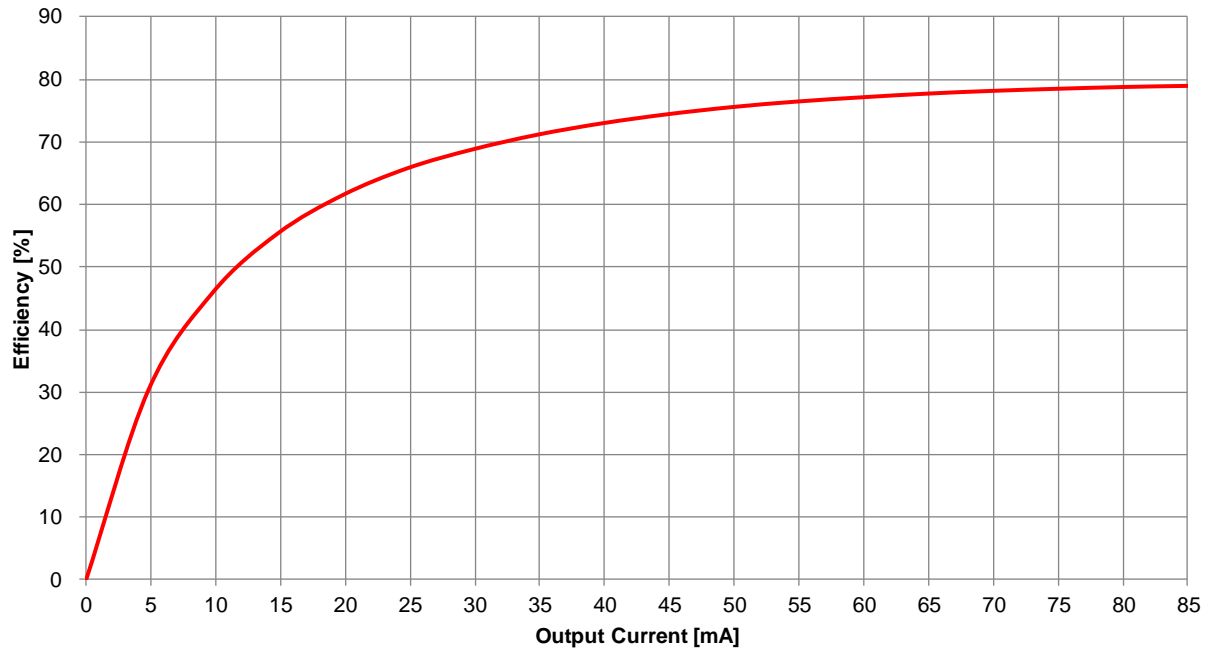

176920522 Efficiency -  $V_{IN} = 12V$ ,  $T_A = 25^\circ C$

—  $V_{OUT} = 5V$

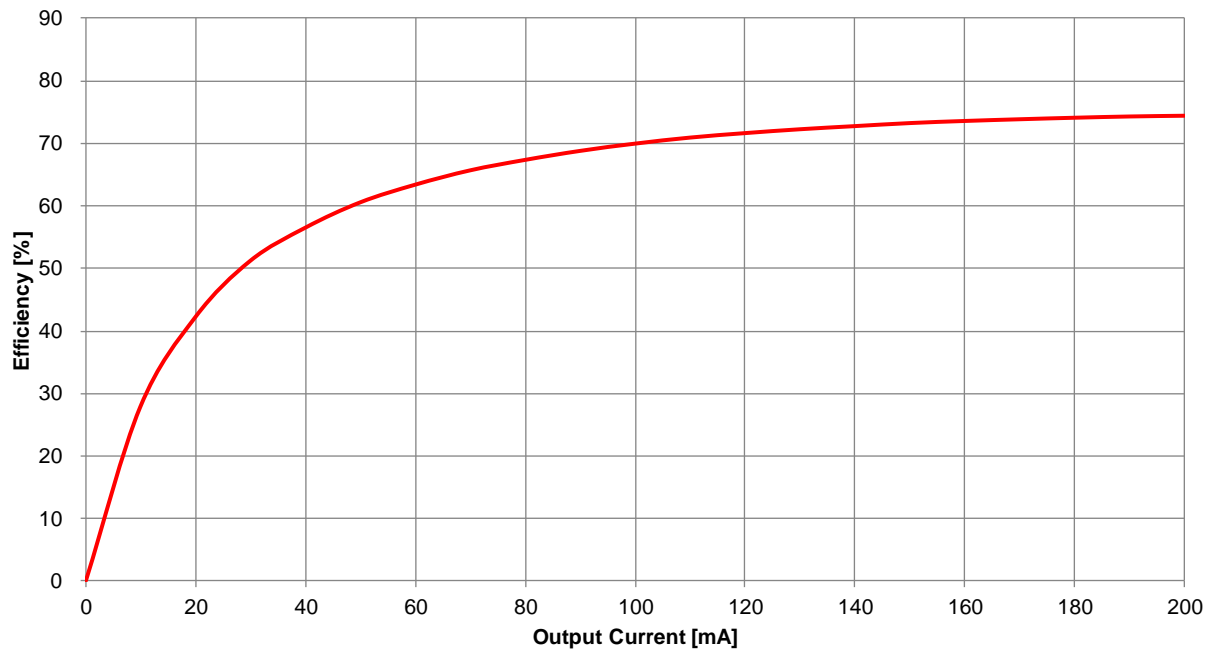

1769205x2, 176881212, 176861512

**MagI<sup>3</sup>C** Power Module  
**FISM** – Fixed Isolated **SMT** Module

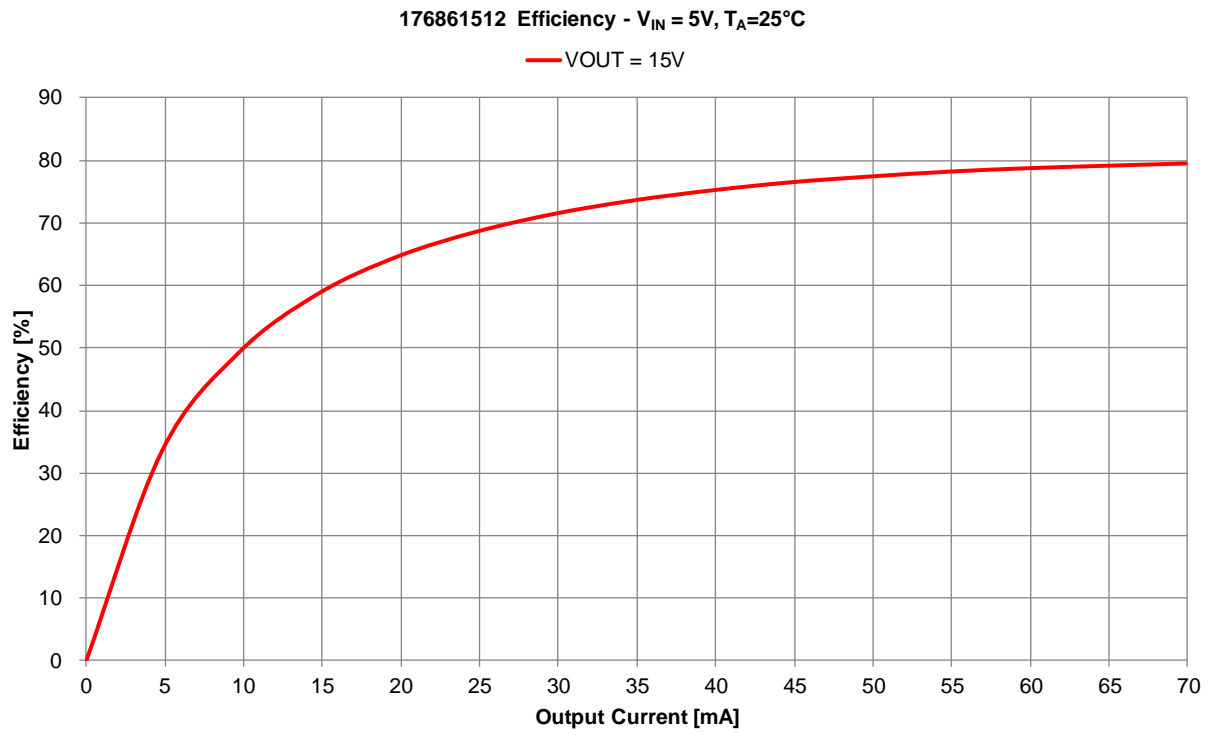

1769205x2, 176881212, 176861512

**MagI<sup>3</sup>C** Power Module  
**FISM – Fixed Isolated SMT Module**



**OUTPUT POWER**

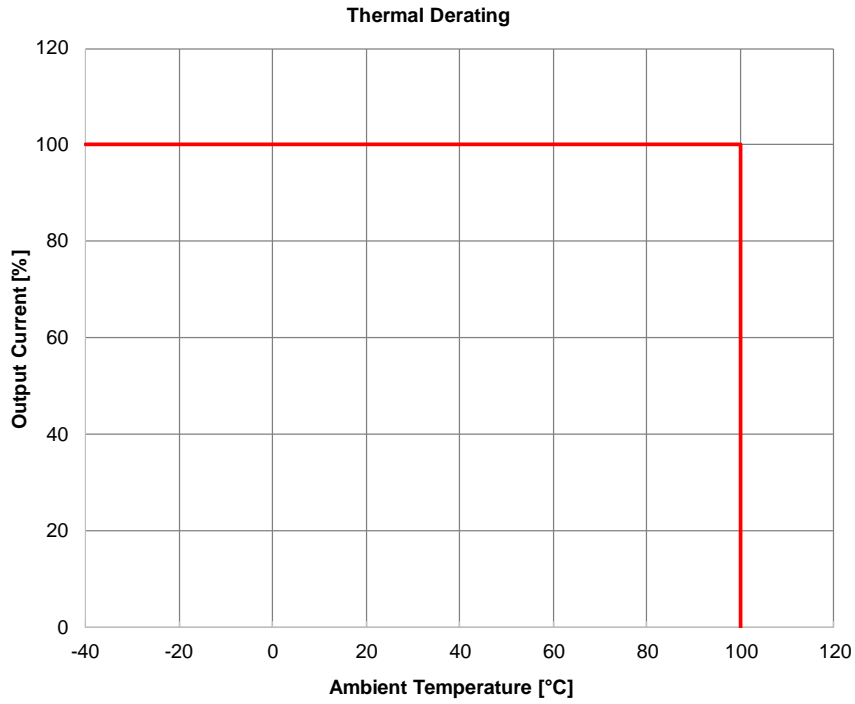

**Note:** Still air (0 – 20LFM / 0 – 0.1m/s)

**I<sub>MOC</sub> DUTY CYCLE**

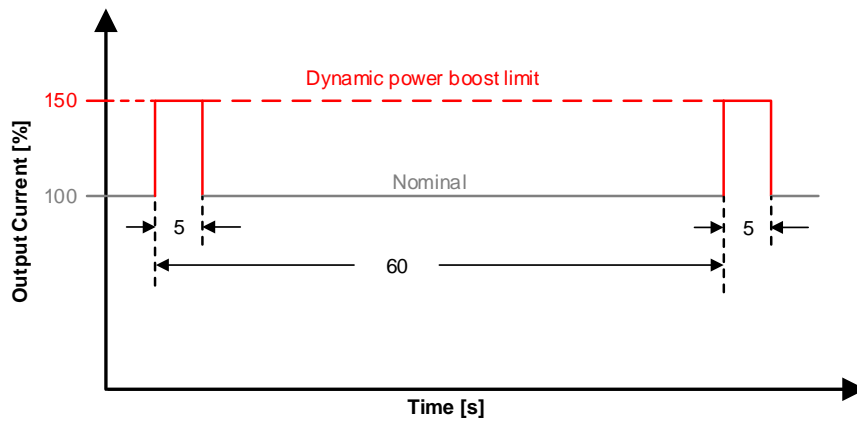

**Note:** The overload current of 150% of I<sub>OUT</sub> can be supplied for maximum 5s and requires a 55s recovery time till next overload event.

1769205x2, 176881212, 176861512

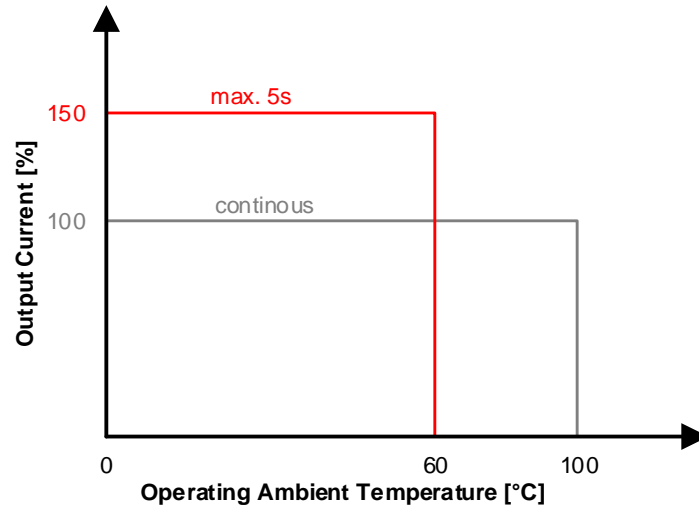
**MagI<sup>3</sup>C** Power Module  
FISM – Fixed Isolated SMT Module**I<sub>MOC</sub> TEMPERATURE DERATING****Note:** Still air (0 – 20LFM / 0 – 0.1m/s)

1769205x2, 176881212, 176861512

**Magl<sup>3</sup>C** Power Module  
**FISM – Fixed Isolated SMT Module**



**OUTPUT VOLTAGE TOLERANCE ENVELOPE**

$V_{IN}=3.3V$  (176920502),  $5V$  (176920512),  $12V$  (176920522)  $V_{OUT}=5V$

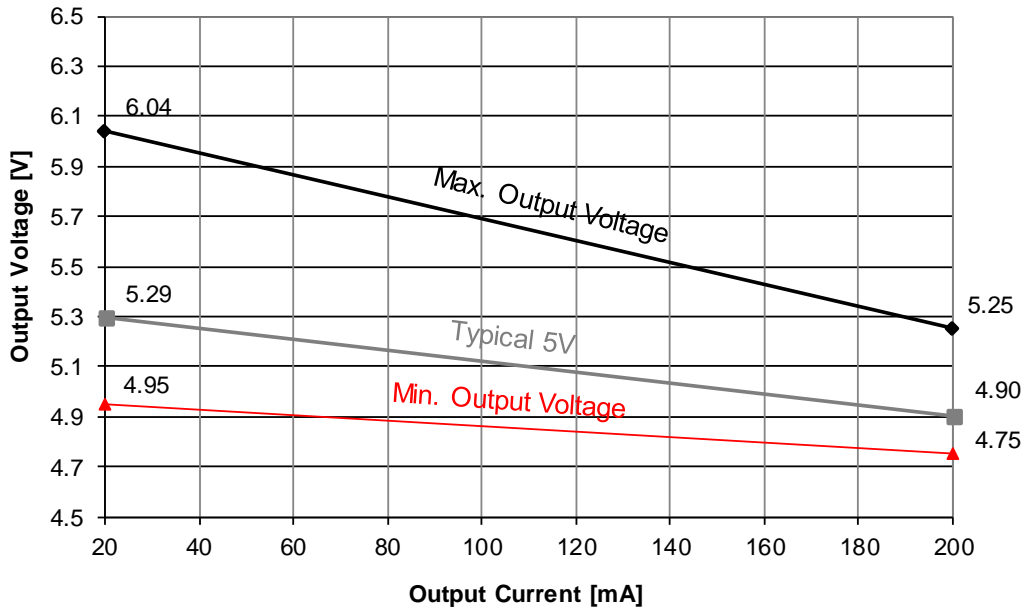

$V_{IN}=5V$  (176881212)  $V_{OUT}=12V$

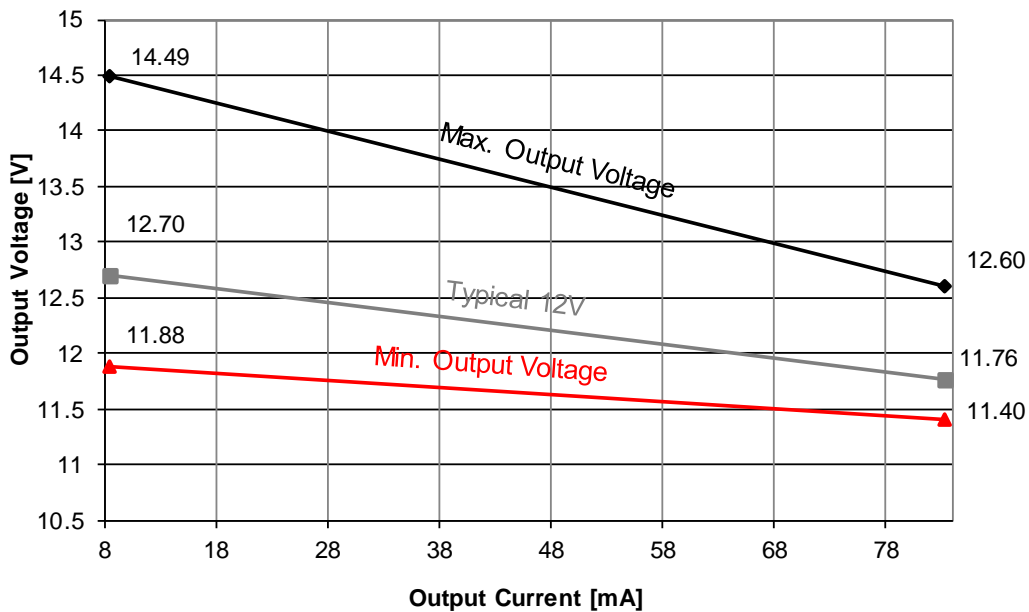

1769205x2, 176881212, 176861512

**MagI<sup>3</sup>C** Power Module  
**FISM – Fixed Isolated SMT Module**



$V_{IN}=5V$  (176861512)  $V_{OUT}=15V$

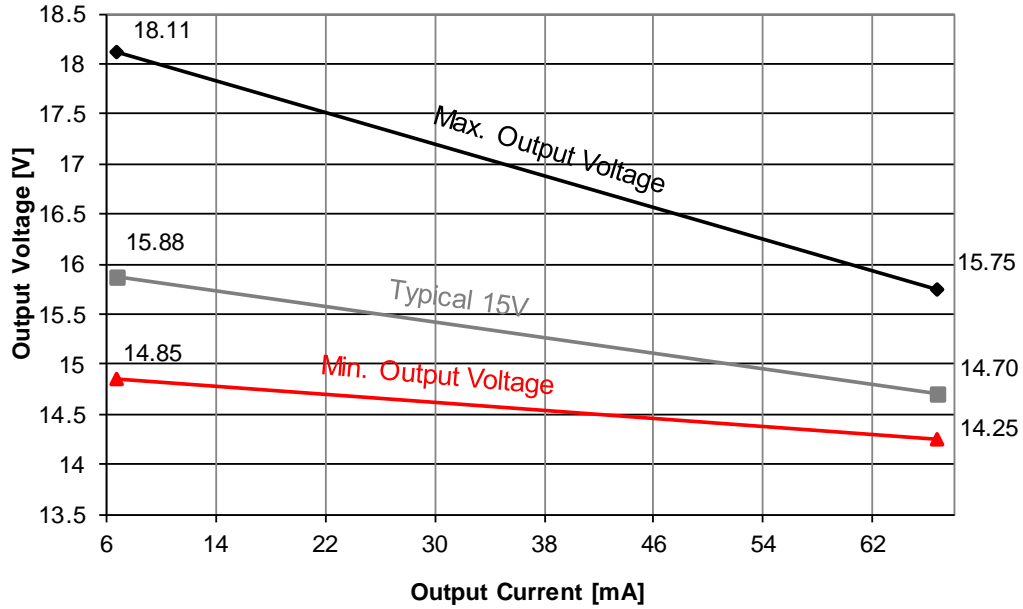

**Note:** Output voltage may exceed +25% of nominal output voltage at zero load

1769205x2, 176881212, 176861512

**MagI<sup>3</sup>C** Power Module  
**FISM** – Fixed Isolated **SMT** Module



## BLOCK DIAGRAM

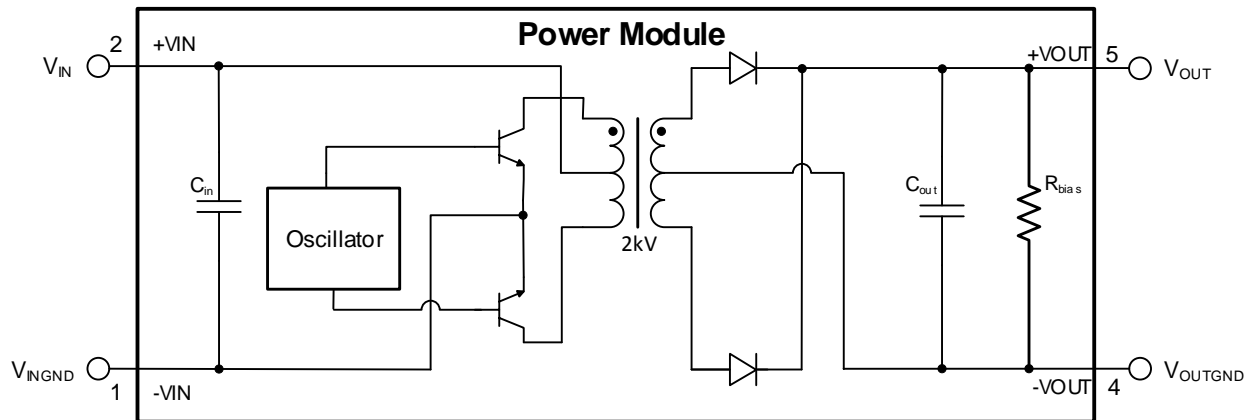

ORDERCODE	SPECIFICATION	C <sub>in</sub>	C <sub>out</sub>	R <sub>bias</sub>
176920502	3.3V <sub>IN</sub> / 5V <sub>OUT</sub>	1uF	1uF	22k
176920512	5V <sub>IN</sub> / 5V <sub>OUT</sub>	1uF	1uF	22k
176920522	12V <sub>IN</sub> / 5V <sub>OUT</sub>	0.47uF	1uF	22k
176881212	5V <sub>IN</sub> / 12V <sub>OUT</sub>	1uF	0.47uF	55k
176861512	5V <sub>IN</sub> / 15V <sub>OUT</sub>	1uF	0.22uF	68k

## CIRCUIT DESCRIPTION

The MagI<sup>3</sup>C power modules 177XXXXX2 are based on a push–pull converter with integrated transistors, rectifying diodes, input and output capacitors and a transformer. The output voltage is unregulated.

Since there is no feedback path from the output to the input, the duty cycle is fixed at 50% and is independent of the load (zero load to full load). The output voltage is defined by the turns ratio of the transformer.

## PROTECTIVE FEATURES

Due to the structure of the MagI<sup>3</sup>C power module, the following protective features are **NOT** implemented:

- Over temperature protection (OTP)
- Overcurrent protection (OCP)
- Output overvoltage protection (OVP)
- Input overvoltage protection
- Short circuit protection (SCP)
- Input reverse polarity protection

**Note:** To protect the source and the MagI<sup>3</sup>C power module in abnormal conditions (e.g. secondary side overload or short circuit) a primary side input fuse (slow blow) is recommended.

1769205x2, 176881212, 176861512

**MagI<sup>3</sup>C** Power Module  
**FISM** – Fixed Isolated **SMT** Module



## APPLICATION CONSIDERATIONS

### Primary side parallel connection

A standard industrial configuration is, that the power modules are supplied by a dc bus voltage. When using multiple modules connected to a single dc bus voltage the individual module inputs have to be decoupled by LC filters. The LC filter reduces the likelihood of oscillations due to parasitics of a layout/routing. Therefore, it is not recommended to connect power modules in parallel on the primary side without an LC filter.

The outputs are not connected to each other and could have individual voltages  $V_{OUT1}$  and  $V_{OUT2}$ .

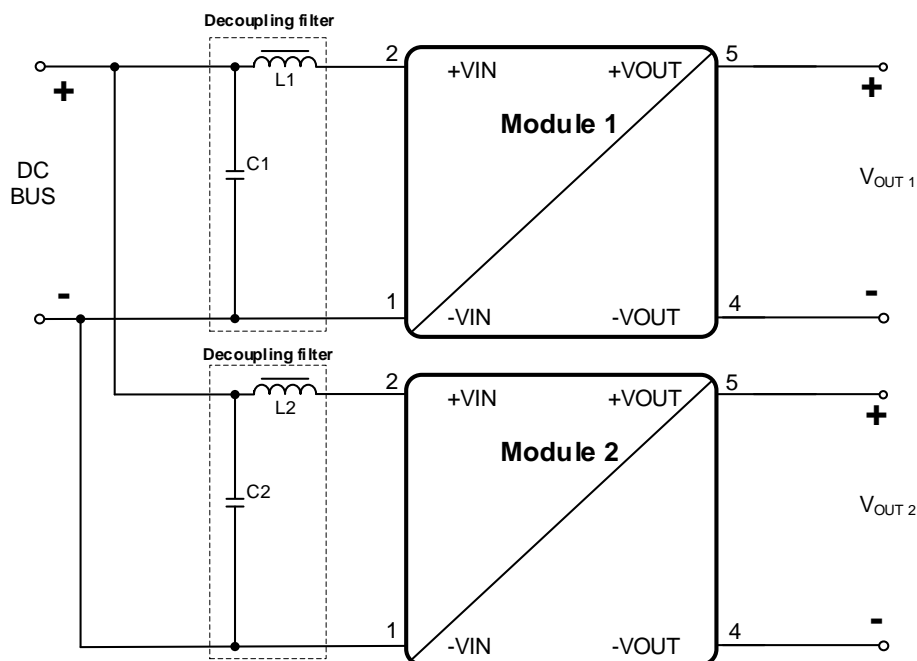

As a starting point for the decoupling filters, use the values of the reference filters – see also “[RADIATED AND CONDUCTED EMISSIONS \(WITH EMI INPUT FILTER\)](#)”. The final appropriate filter for the application has then to be evaluated under operation in the target application by checking e.g. the change of the input ripple voltage.



1769205x2, 176881212, 176861512

**MagI<sup>3</sup>C** Power Module  
**FISM** – Fixed Isolated **SMT** Module



**Secondary side serial connection**

To generate higher output voltage/special rail voltages it is possible to put the outputs of the 176xxxxx2 in series. It is common practice to connect an additional capacitor between the +VOUT and -VOUT.

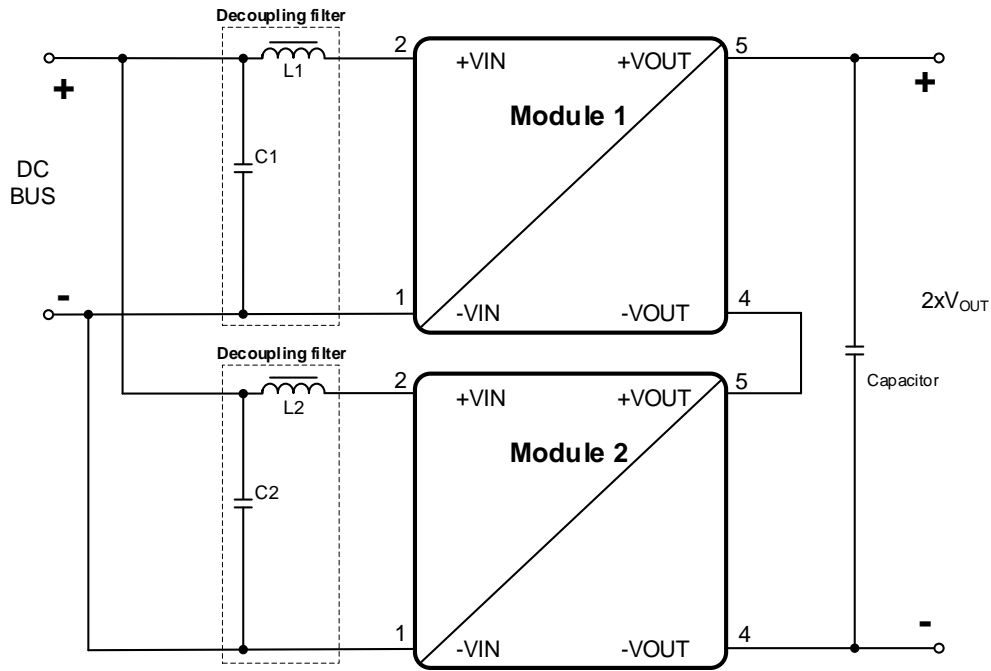

When using multiple modules connected to a single dc bus voltage the individual module inputs have to be decoupled by LC filters. The LC filter reduces the likelihood of oscillations due to parasitics of a layout/routing. Therefore, it is not recommended to connect power modules in parallel on the primary side without an LC filter. See also [Primary side parallel connection](#) on page 25.

1769205x2, 176881212, 176861512

**MagI<sup>3</sup>C** Power Module  
**FISM – Fixed Isolated SMT Module**



**Generating Complementary Output Voltages**

Another common requirement in industrial applications is to provide a complementary voltage (e.g.  $\pm 5V$ ). The circuit below shows how this target can be achieved simply combining a 176xxxxx2 used in a standard configuration (delivering a positive output voltage) with a 176xxxxx2 in a reverse configuration. It is a common practice to connect an additional capacitor across each output voltage.

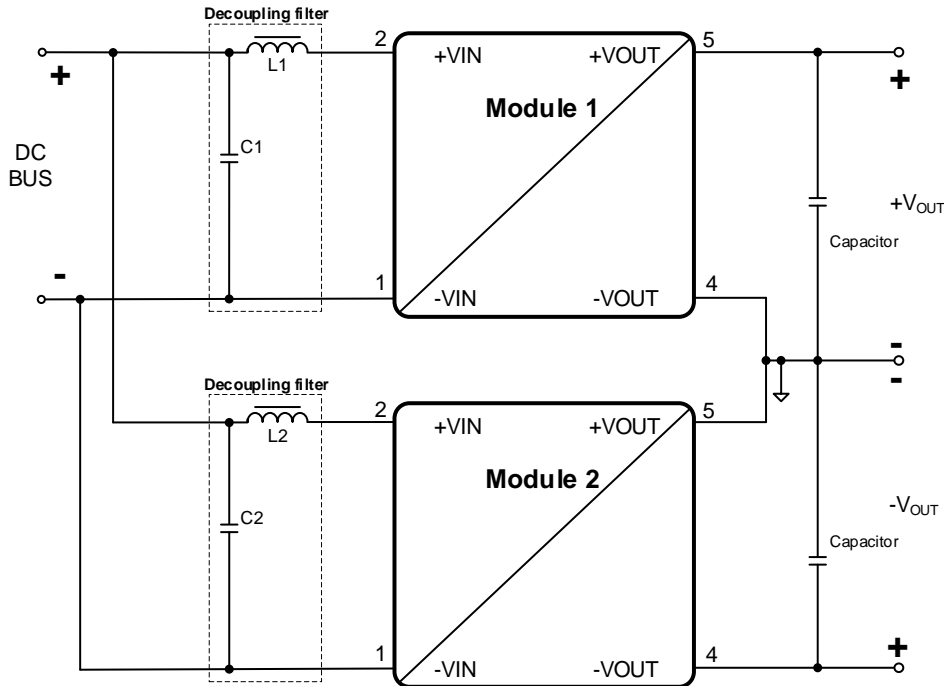

When using multiple modules connected to a single dc bus voltage the individual module inputs have to be decoupled by LC filters. The LC filter reduces the likelihood of oscillations due to parasitics of a layout/routing. Therefore, it is not recommended to connect power modules in parallel on the primary side without an LC filter. See also [Primary side parallel connection](#) on page 25.

**Note:** The decoupling filters are present to avoid oscillations between the two power modules. These filters don't replace the EMI input filter.

**Reverse Polarity Protection**

A simple way of creating an input reverse polarity protection is to place a diode in series with the plus input line. The diode blocks all negative voltages that might be applied at the plus input because of operating reverse biased. Due to the forward voltage drop of the diode the application efficiency drops.

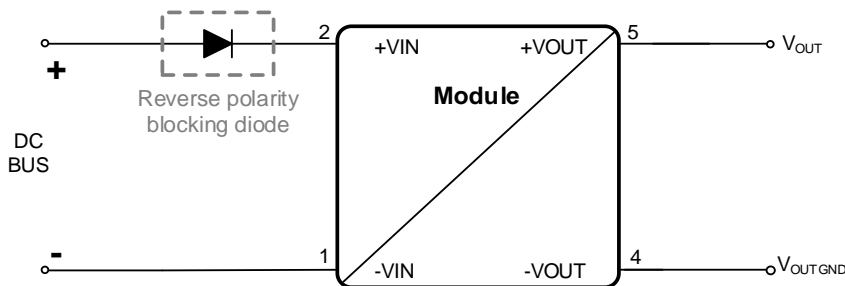

1769205x2, 176881212, 176861512

**Magl<sup>3</sup>C** Power Module  
**FISM – Fixed Isolated SMT Module**



**EVALUATION BOARD SCHEMATIC (17800VISM v.1.0)**

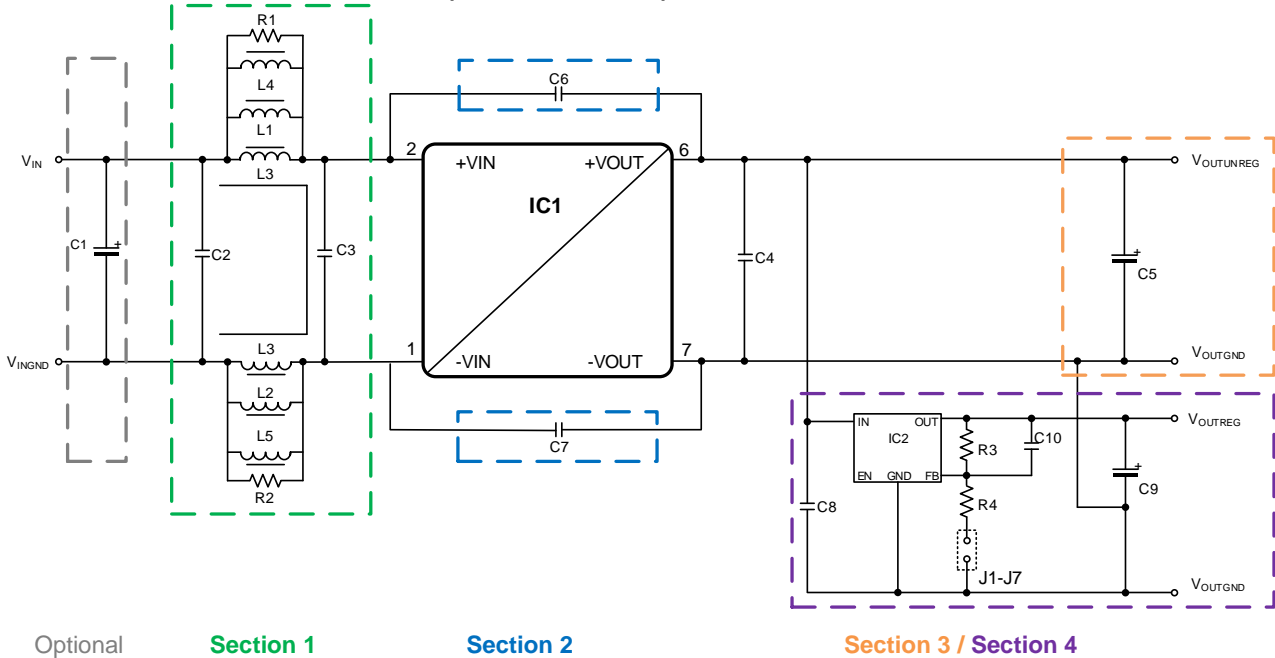

**EMI Section – Section 1 & Section 2**

The FISM evaluation board is a multi-functional EMI optimization tool. It offers the possibility to optimize the EMI behavior based on the application requirements by placing multiple differential (DM) and/or common mode (CM) filters. Therefore, the evaluation board consists of three different filter sections. The tables below show the main component selection possibilities:

Section 1 – green:	
Filter type	Description
DM	C2 + L1
DM (PI)	C2 + L1 + C3
DM	C2 + L2
DM (PI)	C2 + L2 + C3
CM	L1+L2
CM	L3
DM	C2 + L4
DM (PI)	C2 + L4 + C3
DM	C2 + L5
DM (PI)	C2 + L5 + C3
CM	L4 + L5

Section 2 – blue:	
Filter type	Description
CM (Y-Cap)	C6
CM (Y-Cap)	C7
CM (Y-Cap)	C6 + C7

Beside these two basic filter topologies, mixed versions (section 1 + section 2) are also possible with this evaluation board.

The optional additional aluminum electrolytic capacitor C1 is only for evaluation board protection purpose. It is mounted as termination of the supply line and provides a slight damping of possible oscillations of the series resonance circuit represented by the inductance of the supply line and the input capacitance.

1769205x2, 176881212, 176861512

**Magl<sup>3</sup>C Power Module**  
**FISM – Fixed Isolated SMT Module**



**Post regulation option – Section 3 & Section 4**

FEATURE	DESCRIPTION
Regulated output voltage	Output voltage accuracy at 100% load, $V_{IN}$ nominal without LDO $\pm 5\%$ (max) with LDO $\pm 3\%$ (max.) Low dropout voltage: 180mV typical at 200 mA 5V out unregulated turns into 5V out regulated
Adjustable output voltage	5V / 5V standard module turns into 5V / $V_{OUT}$ adjustable
Continuous short circuit protection	LDO output is capable of continuous short circuit

**Note:** Capacitor C10 is not necessary for operation.

**TOP LAYER**

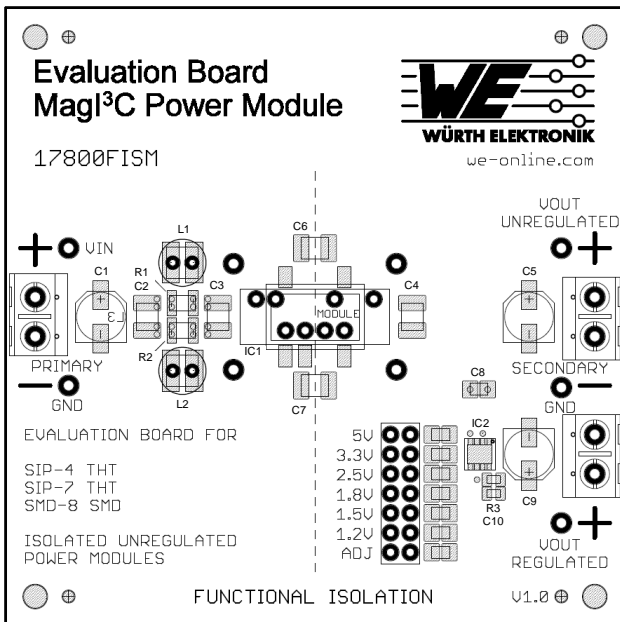

**BOTTOM LAYER**

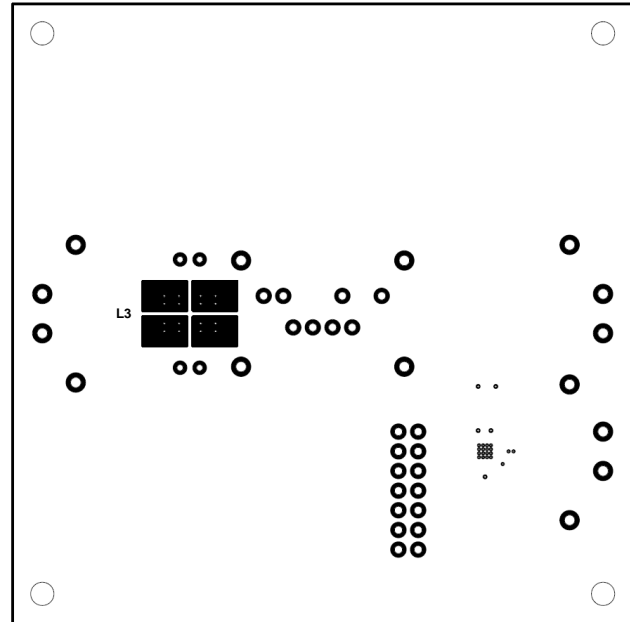

**Bill of Material**

REF. DES.	DESCRIPTION	QUANTITY	ORDER CODE	MANUFACTURER
IC1	FISM Magl <sup>3</sup> C power module	1	176xxxxx2, 1779205x1, 1779205x4	Würth Elektronik
IC2	Micropower, 200-mA Ultra-Low-Dropout Fixed or Adjustable Voltage Regulator	1	LP2986	Texas Instruments
C1	Aluminum electrolytic capacitor, WCAP-ASLU family, 33 $\mu$ F/50V	1	865090645012	Würth Elektronik
C2	Ceramic chip capacitor WCAP-CSGP 50V 1210 X7R (not mounted)	optional	885012209XXX	Würth Elektronik
C3	Ceramic chip capacitor WCAP-CSGP 50V 1210 X7R (not mounted)	optional	885012209XXX	Würth Elektronik

1769205x2, 176881212, 176861512

**MagI<sup>3</sup>C** Power Module  
**FISM – Fixed Isolated SMT Module**

REF. DES.	DESCRIPTION	QUANTITY	ORDER CODE	MANUFACTURER	
C4	Ceramic chip capacitor WCAP-CSGP 50V 1210 X7R (not mounted)	optional	885012209XXX	Würth Elektronik	
C5	Aluminum electrolytic capacitor, WCAP-ASLU family, 33µF/50V	1	865090645012	Würth Elektronik	
C6	Ceramic chip capacitor WCAP-CSSA family 1808 (not mounted)	optional	885362XXXXXX	Würth Elektronik	
C7	Ceramic chip capacitor WCAP-CSSA family 1808 (not mounted)	optional	885362XXXXXX	Würth Elektronik	
C8	Ceramic chip capacitor WCAP-CSGP 16V 0805 X7R	1	885012107014	Würth Elektronik	
C9	Aluminum electrolytic capacitor, WCAP-ASLU family, 33µF/50V	1	865090645012	Würth Elektronik	
C10	(not mounted)	optional		Würth Elektronik	
L1	Filter inductor e.g. WE-PD2 (not mounted)	optional	7447730XX	Würth Elektronik	
L2	Filter inductor e.g. WE-PD2 (not mounted)	optional	7447730XX	Würth Elektronik	
L3	Common mode choke e.g. WE-SL1 (not mounted)	optional	744212XXX	Würth Elektronik	
L4	Filter inductor e.g. WE-CBF family (not mounted)	optional	7427920XX	Würth Elektronik	
L5	Filter inductor e.g. WE-CBF family (not mounted)	optional	7427920XX	Würth Elektronik	
R1	SMD bridge 0Ω resistance 0603/0805	1	-	Various	
R2	SMD bridge 0Ω resistance 0805	1	-	Various	
R3	SMD 1kΩ resistor 0805	1	-	Various	
R4	Set by jumper	4k42 Ω for V <sub>OUT</sub> = 1.5V	1	-	Various
		2k10 Ω for V <sub>OUT</sub> = 1.8V	1	-	Various
		953Ω for V <sub>OUT</sub> = 2.5V	1	-	Various
		590Ω for V <sub>OUT</sub> = 3.3V	1	-	Various
		324Ω for V <sub>OUT</sub> = 5V	1	-	Various
		For adjustable V <sub>OUT</sub> : $V_{OUT} = \left(\frac{R_3}{R_4} + 1\right)$	optional	-	Various
J1	Jumper for selecting the output voltage	1	609976302001	Würth Elektronik	

1769205x2, 176881212, 176861512

**MagI<sup>3</sup>C** Power Module  
**FISM** – Fixed Isolated **SMT** Module



### Filter Suggestions for Conducted and Radiated EMI

The input filter shown in the schematic below is recommended to achieve conducted and radiated EMI compliance according to EN55032 Class B (see results on pages 12 to 16 [RADIATED AND CONDUCTED EMISSIONS \(WITH EMI INPUT FILTER\)](#)).

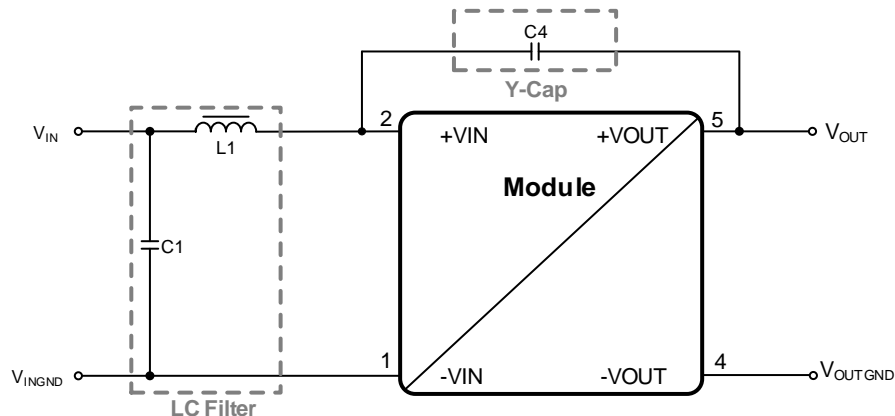

#### MLCC based filter

Model: 3.3V → 5V; 5V → 5V; 5V → 12V; 5V → 15V

DESIGNATOR	DESCRIPTION	FILTER	ORDER CODE	MANUFACTURER
C1	Ceramic chip capacitor 22μF/10V 1210 X7R	LC	885012209006	Würth Elektronik
L1	Filter inductor, 2.2μH, PD2 family		744773022	Würth Elektronik
C4	Ceramic chip capacitor 470pF/250Vac/2500V Impulse Voltage 1808 X7R	Y-Cap	885362210009	Würth Elektronik

Model: 12V → 5V

DESIGNATOR	DESCRIPTION	FILTER	ORDER CODE	MANUFACTURER
C1	Ceramic chip capacitor 10μF/25V 1210 X7R	LC	885012209028	Würth Elektronik
L1	Filter inductor, 10μH, PD2 family		74477310	Würth Elektronik
C4	Ceramic chip capacitor 470pF/250Vac/2500V Impulse Voltage 1808 X7R	Y-Cap	885362210009	Würth Elektronik

#### POLYMER CAP based filter

As a replacement for C1 and L1 following parts can be used for all models (176xxxxx2)

DESIGNATOR	DESCRIPTION	FILTER	ORDER CODE	MANUFACTURER
C1	Aluminum polymer capacitor 150μF/16V WCAP- PSLP	LC	875105345011	Würth Elektronik
L1	Filter inductor, 3.3μH, PD2 family		744773033	Würth Elektronik
C4	Ceramic chip capacitor 470pF/250Vac/2500V Impulse Voltage 1808 X7R	Y-Cap	885362210009	Würth Elektronik

**Note:** C4 has to be rated for an impulse voltage equal or greater than the isolation voltage of the power module itself.

1769205x2, 176881212, 176861512

**Magl<sup>3</sup>C** Power Module  
**FISM – Fixed Isolated SMT Module**



## SOLDER PROFILE

1. Only Pb-Free assembly is recommended according to JEDEC J-STD020.
2. Measure the peak reflow temperature of the Magl<sup>3</sup>C power module in the middle of the top view.
3. Ensure that the peak reflow temperature does not exceed 240°C ±5°C as per JEDEC J-STD020.
4. The reflow time period during peak temperature of 240°C ±5°C must not exceed 30 seconds.
5. Reflow time above liquidus (217°C) must not exceed 150 seconds.
6. Maximum ramp up is rate 3°C per second
7. Maximum ramp down rate is 6°C per second
8. Reflow time from room (25°C) to peak must not exceed 8 minutes as per JEDEC J-STD020.
9. **Maximum number of reflow cycles is one.**
10. **For minimum risk, solder the module in the last reflow cycle of the PCB production.**
11. For soldering process please consider lead material copper (Cu) and lead finish tin (Sn).
12. For solder paste use a standard SAC Alloy such as SAC 305, type 3 or higher.
13. Below profile is valid for convection reflow only
14. Other soldering methods (e.g. vapor phase) are not verified and have to be validated by the customer on his own risk

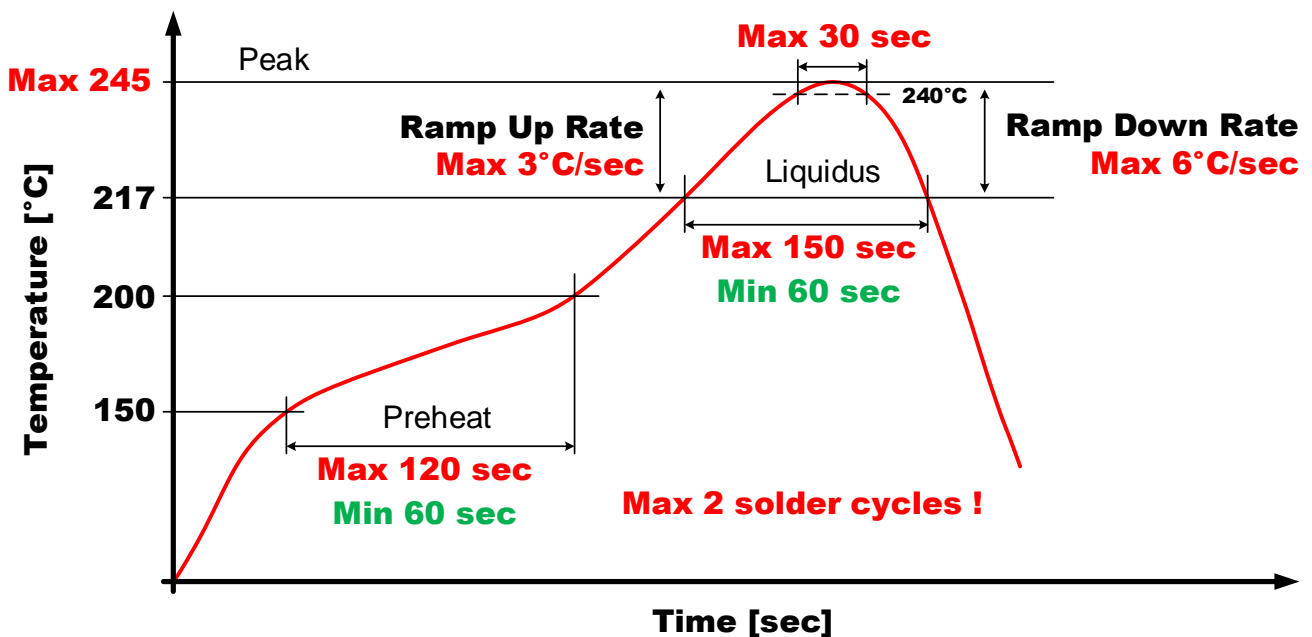

## DEFINITION OF SOLDER CYCLES

1<sup>st</sup> cycle: the module is placed on top of the PCB and reflow soldered

2<sup>nd</sup> cycle: the module remains on top and the PCB and is wave soldered from the bottom

2<sup>nd</sup> cycle: the module remains on top and the board is reflow soldered a second time, exposing the module to the reflow heating profile

**Note:** Module is not allowed to be glued and soldered upside down.

1769205x2, 176881212, 176861512

**MagI<sup>3</sup>C** Power Module  
**FISM** – Fixed Isolated **SMT** Module



**PHYSICAL DIMENSIONS**

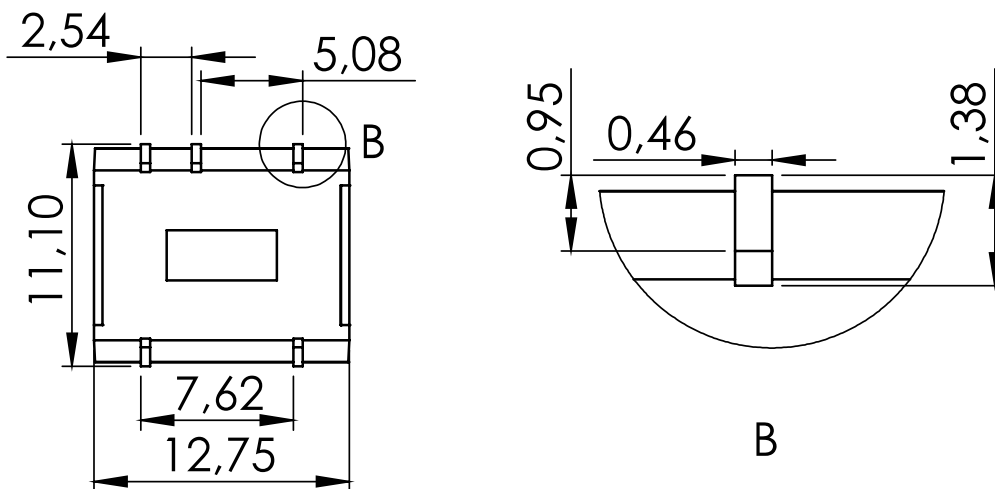
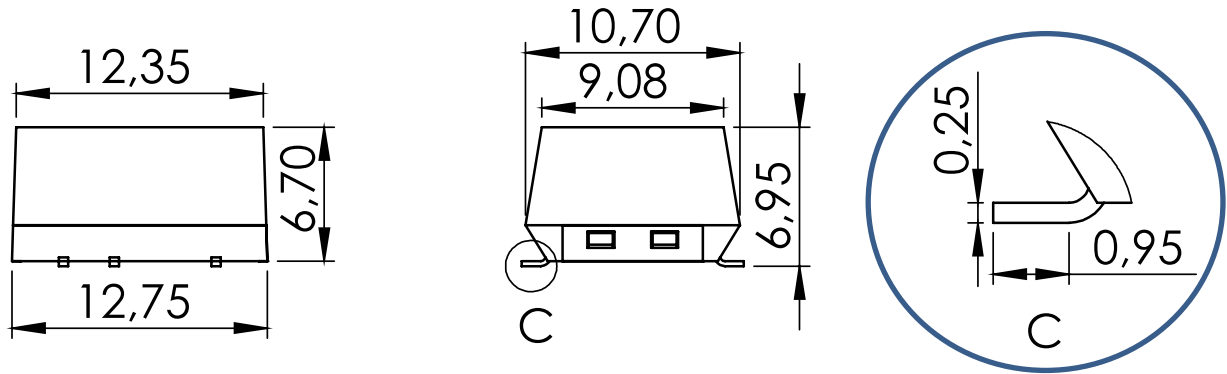

Tolerance: xx.x = ±0.5mm ; xx.xx = ±0.25mm

All dimensions in mm



1769205x2, 176881212, 176861512

**MagI<sup>3</sup>C** Power Module  
**FISM – Fixed Isolated SMT Module**



**RECOMMEND LAND PATTERN**

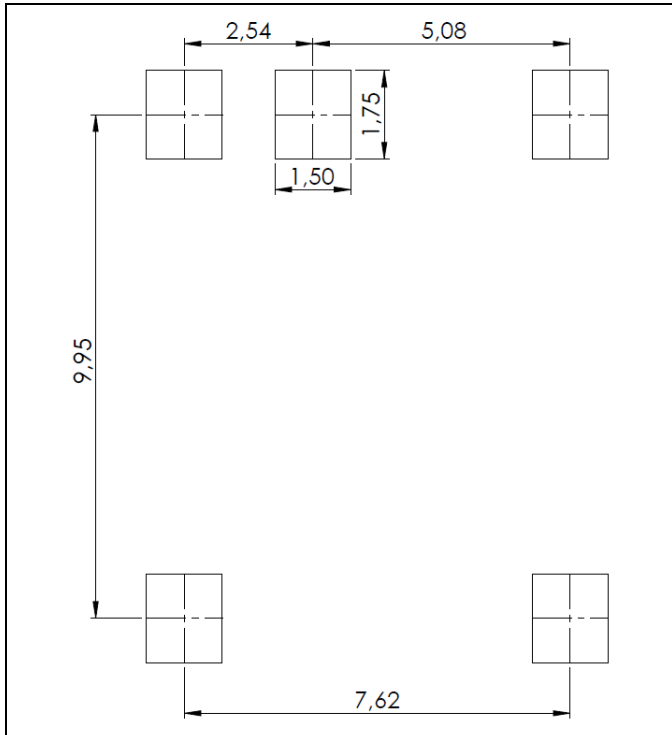

**RECOMMENDED STENCIL DESIGN**

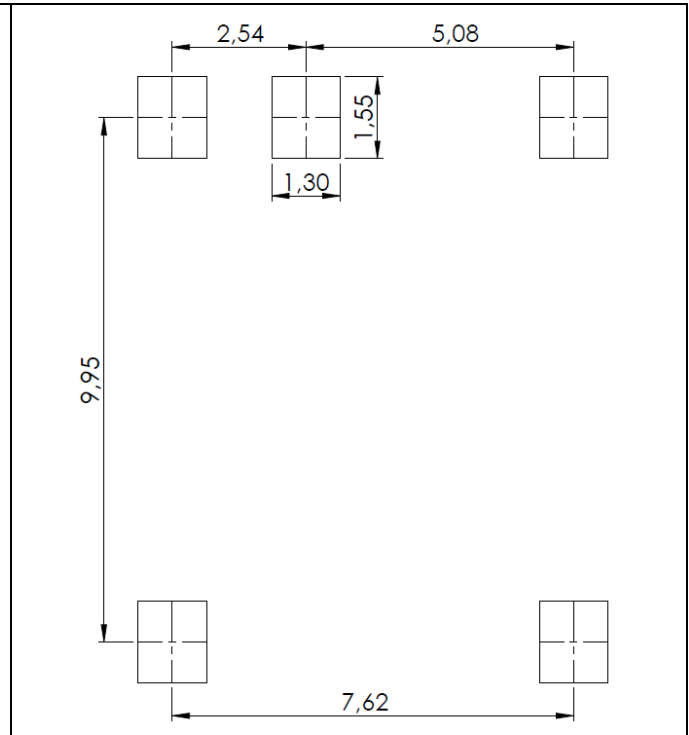

all dimensions in mm

1769205x2, 176881212, 176861512

**MagI<sup>3</sup>C** Power Module  
**FISM** – Fixed Isolated **SMT** Module



**PACKAGING**

Reel (mm)

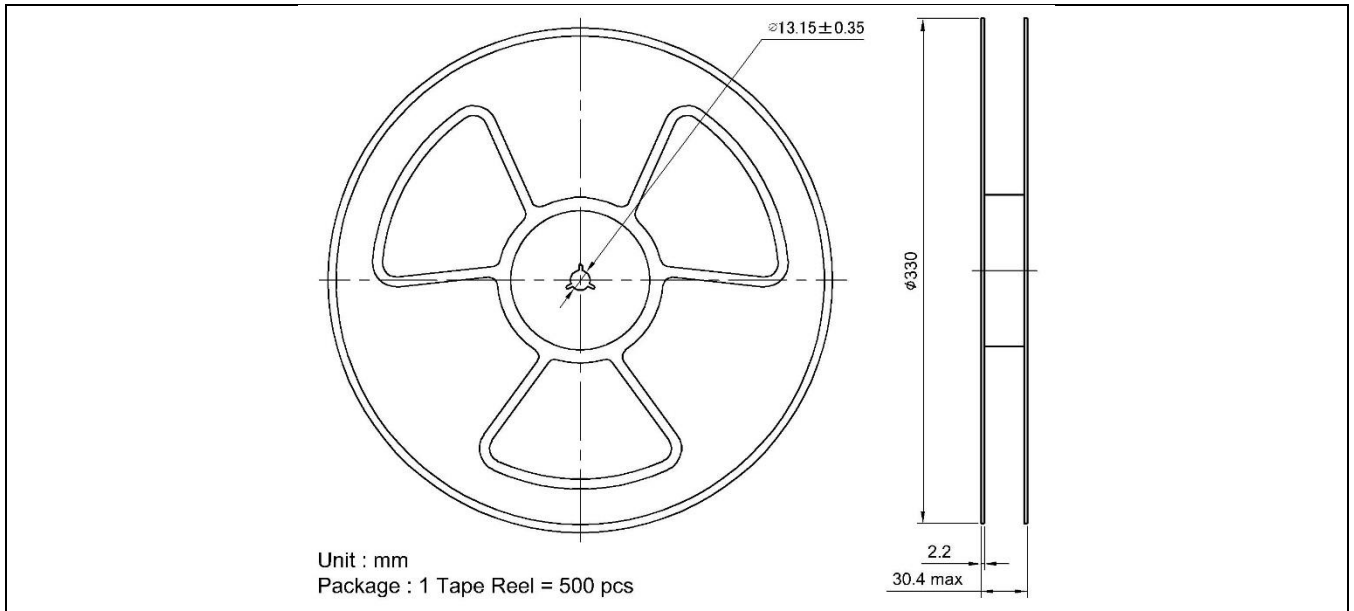

**Tape (mm)**

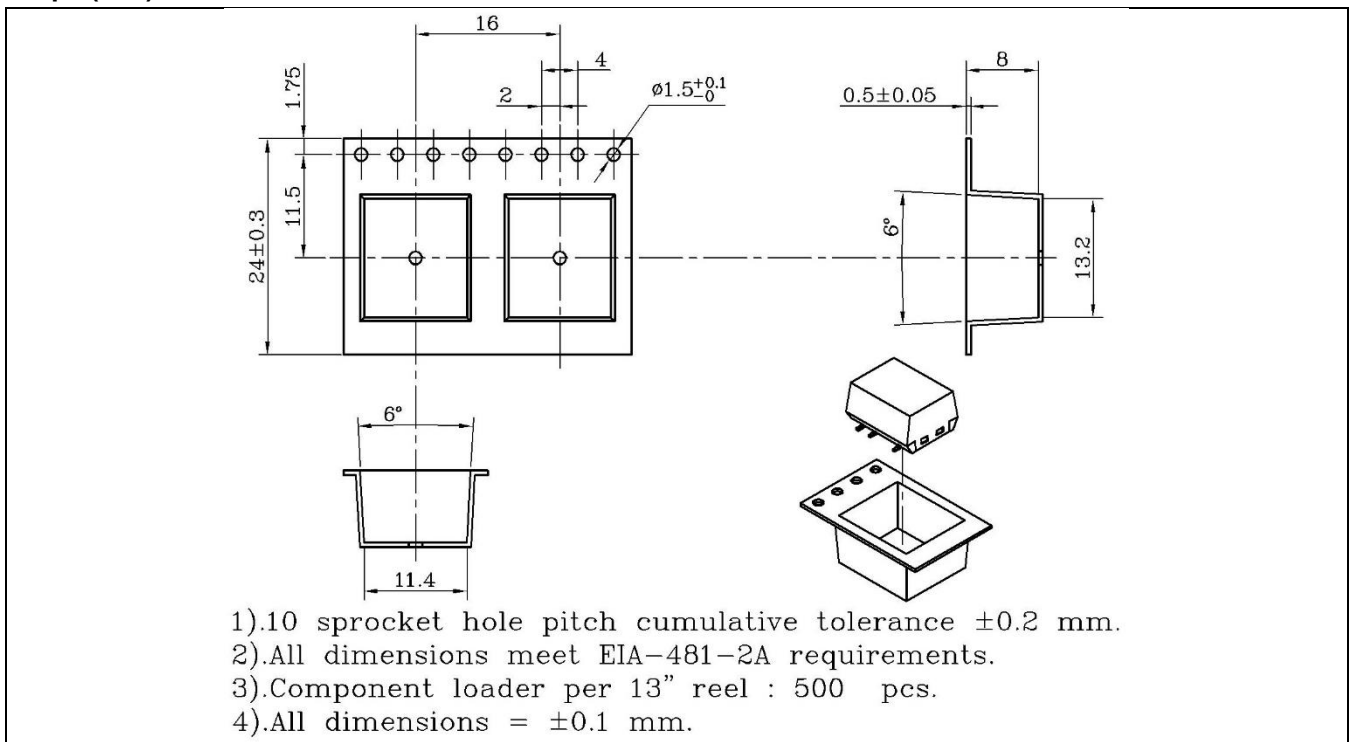

1769205x2, 176881212, 176861512

**MagI<sup>3</sup>C** Power Module  
**FISM** – Fixed Isolated **SMT** Module



#### DOCUMENT HISTORY

Revision	Date	Description	Comment
1.0	July 2018	Release of the final version	

1769205x2, 176881212, 176861512

**MagI<sup>3</sup>C** Power Module  
**FISM – Fixed Isolated SMT Module**



## CAUTIONS AND WARNINGS

**The following conditions apply to all goods within the product series of MagI<sup>3</sup>C of Würth Elektronik eiSos GmbH & Co. KG:**

### General:

All recommendations according to the general technical specifications of the data-sheet have to be complied with.

The usage and operation of the product within ambient conditions which probably alloy or harm the component surface has to be avoided.

The responsibility for the applicability of customer specific products and use in a particular customer design is always with in the authority of the customer. All technical specifications for standard products do also apply for customer specific products.

Residual washing varnish agent that is used during the production to clean the application might change the characteristics of the body, pins or termination. The washing varnish agent could have a negative effect on the long term function of the product.

Direct mechanical impact to the product shall be prevented as the material of the body, pins or termination could flake or in the worst case it could break. As these devices are sensitive to electrostatic discharge customer shall follow proper IC Handling Procedures.

Customer acknowledges and agrees that it is solely responsible for compliance with all legal, regulatory and safety-related requirements concerning its products, and any use of Würth Elektronik eiSos GmbH & Co. KG components in its applications, notwithstanding any applications-related information or support that may be provided by Würth Elektronik eiSos GmbH & Co. KG. Customer represents and agrees that it has all the necessary expertise to create and implement safeguards which anticipate dangerous consequences of failures, monitor failures and their consequences lessen the likelihood of failures that might cause harm and take appropriate remedial actions. Customer will fully indemnify Würth Elektronik eiSos and its representatives against any damages arising out of the use of any Würth Elektronik eiSos GmbH & Co. KG components in safety-critical applications.

### Product specific:

Follow all instructions mentioned in the datasheet, especially:

- The solder profile has to comply with the technical reflow or wave soldering specification, otherwise this will void the warranty.
- All products are supposed to be used before the end of the period of 12 months based on the product date-code.
- Violation of the technical product specifications such as exceeding the absolute maximum ratings will void the warranty.
- It is also recommended to return the body to the original moisture proof bag and reseal the moisture proof bag again.
- ESD prevention methods need to be followed for manual handling and processing by machinery.

1769205x2, 176881212, 176861512

**MagI<sup>3</sup>C** Power Module  
**FISM – Fixed Isolated SMT Module**



## IMPORTANT NOTES

The following conditions apply to all goods within the product range of Würth Elektronik eiSos GmbH & Co. KG:

### 1. General Customer Responsibility

Some goods within the product range of Würth Elektronik eiSos GmbH & Co. KG contain statements regarding general suitability for certain application areas. These statements about suitability are based on our knowledge and experience of typical requirements concerning the areas, serve as general guidance and cannot be estimated as binding statements about the suitability for a customer application. The responsibility for the applicability and use in a particular customer design is always solely within the authority of the customer. Due to this fact it is up to the customer to evaluate, where appropriate to investigate and decide whether the device with the specific product characteristics described in the product specification is valid and suitable for the respective customer application or not. Accordingly, the customer is cautioned to verify that the datasheet is current before placing orders.

### 2. Customer Responsibility related to Specific, in particular Safety-Relevant Applications

It has to be clearly pointed out that the possibility of a malfunction of electronic components or failure before the end of the usual lifetime cannot be completely eliminated in the current state of the art, even if the products are operated within the range of the specifications. In certain customer applications requiring a very high level of safety and especially in customer applications in which the malfunction or failure of an electronic component could endanger human life or health it must be ensured by most advanced technological aid of suitable design of the customer application that no injury or damage is caused to third parties in the event of malfunction or failure of an electronic component.

### 3. Best Care and Attention

Any product-specific notes, warnings and cautions must be strictly observed.

### 4. Customer Support for Product Specifications

Some products within the product range may contain substances which are subject to restrictions in certain jurisdictions in order to serve specific technical requirements. Necessary information is available on request. In this case the field sales engineer or the internal sales person in charge should be contacted who will be happy to support in this matter.

### 5. Product R&D

Due to constant product improvement product specifications may change from time to time. As a standard reporting procedure of the Product Change Notification (PCN) according to the JEDEC-Standard we inform about minor and major changes. In case of further queries regarding the PCN, the field sales engineer or the internal sales person in charge should be contacted. The basic responsibility of the customer as per Section 1 and 2 remains unaffected.

### 6. Product Life Cycle

Due to technical progress and economical evaluation we also reserve the right to discontinue production and delivery of products. As a standard reporting procedure of the Product Termination Notification (PTN) according to the JEDEC-Standard we will inform at an early stage about inevitable product discontinuance. According to this we cannot guarantee that all products within our product range will always be available. Therefore it needs to be verified with the field sales engineer or the internal sales person in charge about the current product availability expectancy before or when the product for application design-in disposal is considered. The approach named above does not apply in the case of individual agreements deviating from the foregoing for customer-specific products.

### 7. Property Rights

All the rights for contractual products produced by Würth Elektronik eiSos GmbH & Co. KG on the basis of ideas, development contracts as well as models or templates that are subject to copyright, patent or commercial protection supplied to the customer will remain with Würth Elektronik eiSos GmbH & Co. KG. Würth Elektronik eiSos GmbH & Co. KG does not warrant or represent that any license, either expressed or implied, is granted under any patent right, copyright, mask work right, or other intellectual property right relating to any combination, application, or process in which Würth Elektronik eiSos GmbH & Co. KG components or services are used.

### 8. General Terms and Conditions

Unless otherwise agreed in individual contracts, all orders are subject to the current version of the "General Terms and Conditions of Würth Elektronik eiSos Group", last version available at [www.we-online.com](http://www.we-online.com).

## Данный компонент на территории Российской Федерации

### Вы можете приобрести в компании MosChip.

Для оперативного оформления запроса Вам необходимо перейти по данной ссылке:

<http://moschip.ru/get-element>

Вы можете разместить у нас заказ для любого Вашего проекта, будь то серийное производство или разработка единичного прибора.

В нашем ассортименте представлены ведущие мировые производители активных и пассивных электронных компонентов.

Нашей специализацией является поставка электронной компонентной базы двойного назначения, продукции таких производителей как XILINX, Intel (ex.ALTERA), Vicor, Microchip, Texas Instruments, Analog Devices, Mini-Circuits, Amphenol, Glenair.

Сотрудничество с глобальными дистрибьюторами электронных компонентов, предоставляет возможность заказывать и получать с международных складов практически любой перечень компонентов в оптимальные для Вас сроки.

На всех этапах разработки и производства наши партнеры могут получить квалифицированную поддержку опытных инженеров.

Система менеджмента качества компании отвечает требованиям в соответствии с ГОСТ Р ИСО 9001, ГОСТ РВ 0015-002 и ЭС РД 009

### Офис по работе с юридическими лицами:

105318, г.Москва, ул.Щербаковская д.3, офис 1107, 1118, ДЦ «Щербаковский»

Телефон: +7 495 668-12-70 (многоканальный)

Факс: +7 495 668-12-70 (доб.304)

E-mail: [info@moschip.ru](mailto:info@moschip.ru)

Skype отдела продаж:

moschip.ru

moschip.ru\_4

moschip.ru\_6

moschip.ru\_9