



Common Mode Chokes - BU Series



These low cost, high performance choke coils are designed to virtually eliminate line conducted common mode noise.

The BU9S and BU9HS families are ideal for signal line applications; the others can be used in switching power supplies and power supply circuits. All provide significant attenuation of common mode noise across a broad range of frequencies.

For height-restricted applications, the BU9 and BU9S filters are available in a horizontal configuration, which reduces their height to under half an inch (12.5 mm).

For free evaluation samples, contact Coilcraft or request them on-line at www.coilcraft.com.

Core material Ferrite

Terminations RoHS compliant tin-silver over copper. Other terminations available at additional cost.

Weight BU9: 3.1 – 4.1 g
 BU9H: 3.1 – 4.1 g
 BU9HS: 3.1 – 3.8 g
 BU9S: 3.1 – 3.8 g
 BU10: 6.2 – 6.6 g
 BU15: 14.6 – 16.1 g
 BU16: 15.1 – 18.0 g

Ambient temperature –40°C to +125°C

Storage temperature Component: –40°C to +125°C.
 Packaging: –40°C to +80°C

Moisture Sensitivity Level (MSL) 1 (unlimited floor life at <30°C / 85% relative humidity)

Failures in Time (FIT) / Mean Time Between Failures (MTBF)
 38 per billion hours / 26,315,789 hours, calculated per Telcordia SR-332

Packaging BU9: 100 per tray
 BU9H: 100 per tray
 BU9HS: 100 per tray
 BU9S: 100 per tray
 BU10: 100 per tray
 BU15: 80 per tray
 BU16: 80 per tray

PCB washing Only pure water or alcohol recommended

Coilcraft[®]

Specifications subject to change without notice.
 Please check our website for latest information.

Document 260-1 Revised 09/09/09

1102 Silver Lake Road Cary, Illinois 60013 Phone 847/639-6400 Fax 847/639-1469

E-mail info@coilcraft.com Web <http://www.coilcraft.com>



Common Mode Chokes - BU9, BU9H Series

Part number	Impedance max (kOhms)	Frequency range @ 75% of impedance max	DCR ¹ (Ohms)	Current max (Aac)	Inductance ² L1, L2 min (mH)	Inductance difference L1 - L2 max (µH)
BU9-103R25BL	60 @ 220 kHz	200 – 240 kHz	3.5	0.25	10.0	200
BU9-2820R5BL	53 @ 410 kHz	310 – 430 kHz	1.0	0.50	2.8	50
BU9-1320R7BL	52 @ 660 kHz	600 – 700 kHz	0.5	0.70	1.3	50
BU9-6011R0BL	36 @ 1300 kHz	1200 – 1400 kHz	0.2	1.00	0.6	25
BU9-2011R6BL	5.4 @ 1500 kHz	900 – 2100 kHz	0.1	1.60	0.2	25
BU9H-103R25BL	60 @ 220 kHz	200 – 240 kHz	3.5	0.25	10.0	200
BU9H-2820R5BL	53 @ 410 kHz	310 – 430 kHz	1.0	0.50	2.8	50
BU9H-1320R7BL	52 @ 660 kHz	600 – 700 kHz	0.5	0.70	1.3	50
BU9H-6011R0BL	36 @ 1300 kHz	1200 – 1400 kHz	0.2	1.00	0.6	25
BU9H-2011R6BL	5.4 @ 1500 kHz	900 – 2100 kHz	0.1	1.60	0.2	25

1. DCR is per winding
2. Inductance tested at 1 kHz, 1 Vrms, 0 Aac on an Agilent/HP 4284A LCR-meter or equivalent.
3. 1000 Vrms typical isolation between windings.
4. Electrical specifications at 25°C.

Typical Attenuation



Typical Impedance

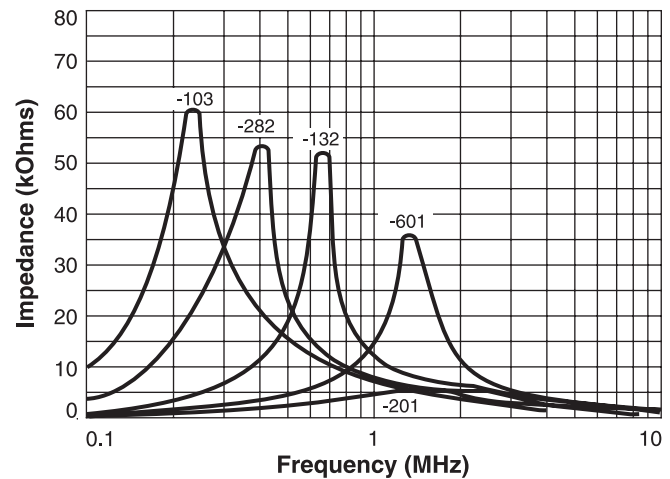

BU9

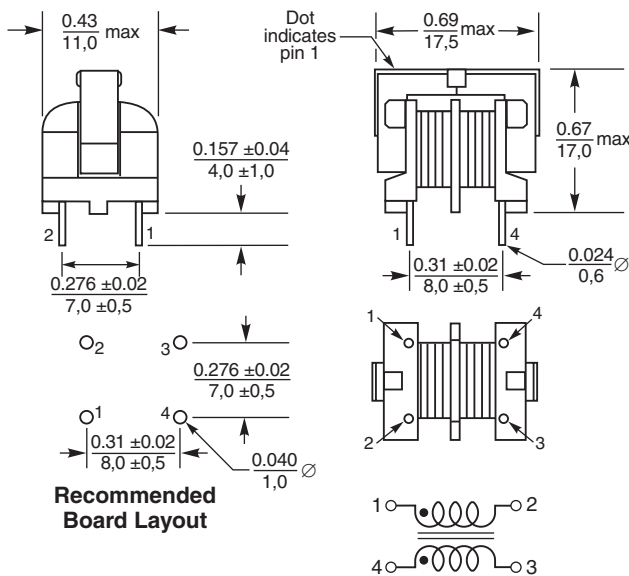

BU9H

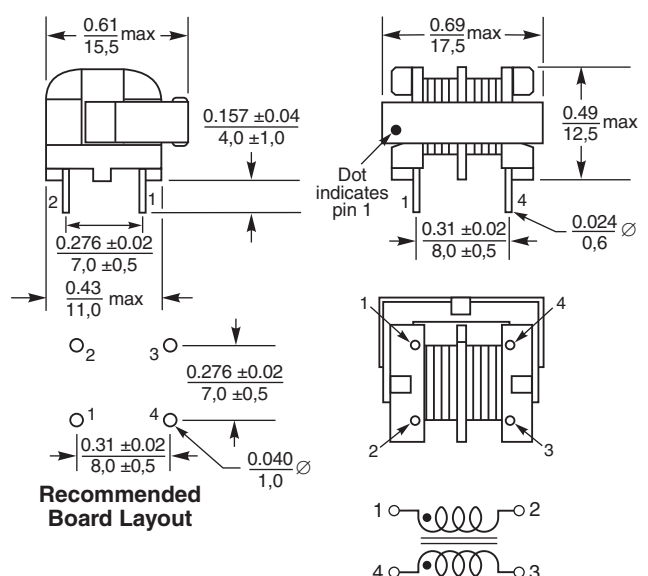

Specifications subject to change without notice.
Please check our website for latest information.

Document 260-2 Revised 09/09/09

1102 Silver Lake Road Cary, Illinois 60013 Phone 847/639-6400 Fax 847/639-1469

E-mail info@coilcraft.com Web <http://www.coilcraft.com>



Common Mode Chokes - BU9S, BU9HS Series

Part number	Impedance max (kOhms)	Frequency range @ 75% of impedance max	DCR ¹ (Ohms)	Current max (Aac)	Inductance ² L1, L2 min (mH)	Inductance difference L1 - L2 max (µH)
BU9S-153R15BL	71 @ 210 kHz	190 – 230 kHz	5.0	0.15	15.0	300
BU9S-7020R3BL	66 @ 330 kHz	300 – 360 kHz	2.5	0.30	7.0	200
BU9HS-153R15BL	71 @ 210 kHz	190 – 230 kHz	5.0	0.15	15.0	300
BU9HS-7020R3BL	66 @ 330 kHz	300 – 360 kHz	2.5	0.30	7.0	200

1. DCR is per winding
2. Inductance tested at 1 kHz, 1 Vrms, 0 Adc on an Agilent/HP 4284A LCR-meter or equivalent.
3. 1000 Vrms typical isolation between windings.
4. Electrical specifications at 25°C.

Typical Attenuation



Typical Impedance

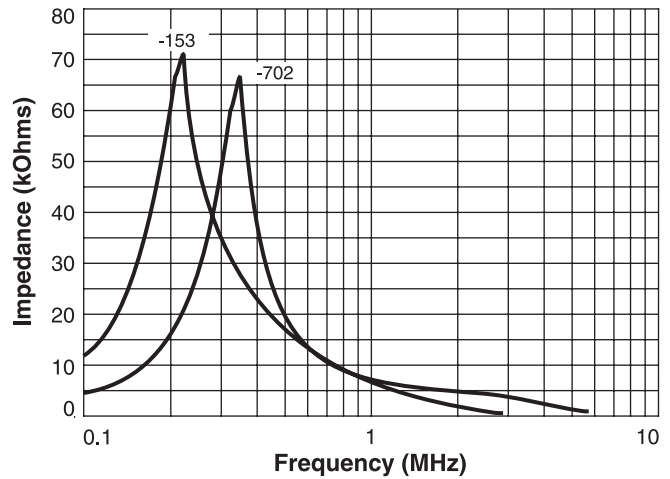

BU9S



BU9HS



Specifications subject to change without notice.
Please check our website for latest information.

Document 260-3 Revised 09/09/09

1102 Silver Lake Road Cary, Illinois 60013 Phone 847/639-6400 Fax 847/639-1469

E-mail info@coilcraft.com Web <http://www.coilcraft.com>



Common Mode Chokes - BU10 Series

Part number	Impedance max (kOhms)	Frequency range @ 75% of impedance max	DCR ¹ (Ohms)	Current max (Aac)	Inductance ² L1, L2 min (mH)	Inductance difference L1 - L2 max (µH)
BU10-1811R2BL	3.9 @ 1.8 MHz	1000 – 3200 kHz	0.20	1.20	0.18	30
BU10-1311R6BL	2.2 @ 2.2 MHz	800 – 2000 kHz	0.12	1.60	0.13	20
BU10-1012R2BL	1.6 @ 3.1 MHz	1300 – 8900 kHz	0.08	2.20	0.10	15
BU10-6003R0BL	1.0 @ 3.0 MHz	800 – 10000 kHz	0.04	3.00	0.06	10

1. DCR is per winding
2. Inductance tested at 1 kHz, 1 Vrms, 0 Aac on an Agilent/HP 4284A LCR-meter or equivalent.
3. 1000 Vrms typical isolation between windings.
4. Electrical specifications at 25°C.

Typical Attenuation



Typical Impedance



Recommended Board Layout



Specifications subject to change without notice.
Please check our website for latest information.

Document 260-4 Revised 09/09/09

1102 Silver Lake Road Cary, Illinois 60013 Phone 847/639-6400 Fax 847/639-1469

E-mail info@coilcraft.com Web <http://www.coilcraft.com>



Common Mode Chokes - BU15 Series

Part number	Impedance max (kOhms)	Frequency range @ 75% of impedance max	DCR ¹ (Ohms)	Current max (Aac)	Inductance ² L1, L2 min (mH)	Inductance difference L1 - L2 max (µH)
BU15-4530R4BL	400 @ 230 kHz	140 – 160 kHz	3.0	0.40	45.0	300
BU15-1430R7BL	115 @ 470 kHz	400 – 650 kHz	1.0	0.70	14.0	300
BU15-7521R0BL	60 @ 600 kHz	420 – 720 kHz	0.6	1.00	7.5	150
BU15-4421R3BL	36 @ 670 kHz	430 – 1000 kHz	0.3	1.30	4.4	100
BU15-2721R6BL	20 @ 1000 kHz	510 – 1400 kHz	0.2	1.60	2.7	60

1. DCR is per winding
2. Inductance tested at 1 kHz, 1 Vrms, 0 Aac on an Agilent/HP 4284A LCR-meter or equivalent.
3. 1000 Vrms typical isolation between windings.
4. Electrical specifications at 25°C.

Typical Attenuation



Typical Impedance



Recommended Board Layout



Specifications subject to change without notice.
Please check our website for latest information.

Document 260-5 Revised 09/09/09

1102 Silver Lake Road Cary, Illinois 60013 Phone 847/639-6400 Fax 847/639-1469

E-mail info@coilcraft.com Web <http://www.coilcraft.com>



Common Mode Chokes - BU16 Series

Part number	Impedance max (kOhms)	Frequency range @ 75% of impedance max	DCR ¹ (Ohms)	Current max (Aac)	Inductance ² L1, L2 min (mH)	Inductance difference L1 - L2 max (µH)
BU16-4530R5BL	285 @ 150 kHz	140 – 160 kHz	2.3	0.50	45.0	900
BU16-2530R7BL	120 @ 200 kHz	160 – 220 kHz	1.3	0.70	25.0	500
BU16-1031R0BL	60 @ 320 kHz	260 – 390 kHz	0.5	1.00	10.0	200
BU16-4021R5BL	20 @ 470 kHz	360 – 600 kHz	0.3	1.50	4.0	80
BU16-2022R0BL	11 @ 690 kHz	450 – 900 kHz	0.2	2.00	2.0	50

1. DCR is per winding
2. Inductance tested at 1 kHz, 1 Vrms, 0 Aac on an Agilent/HP 4284A LCR-meter or equivalent.
3. 1000 Vrms typical isolation between windings.
4. Electrical specifications at 25°C.

Typical Attenuation



Typical Impedance



Recommended Board Layout



Specifications subject to change without notice.
Please check our website for latest information.

Document 260-6 Revised 09/09/09

1102 Silver Lake Road Cary, Illinois 60013 Phone 847/639-6400 Fax 847/639-1469

E-mail info@coilcraft.com Web <http://www.coilcraft.com>

Данный компонент на территории Российской Федерации

Вы можете приобрести в компании MosChip.

Для оперативного оформления запроса Вам необходимо перейти по данной ссылке:

<http://moschip.ru/get-element>

Вы можете разместить у нас заказ для любого Вашего проекта, будь то серийное производство или разработка единичного прибора.

В нашем ассортименте представлены ведущие мировые производители активных и пассивных электронных компонентов.

Нашей специализацией является поставка электронной компонентной базы двойного назначения, продукции таких производителей как XILINX, Intel (ex.ALTERA), Vicor, Microchip, Texas Instruments, Analog Devices, Mini-Circuits, Amphenol, Glenair.

Сотрудничество с глобальными дистрибьюторами электронных компонентов, предоставляет возможность заказывать и получать с международных складов практически любой перечень компонентов в оптимальные для Вас сроки.

На всех этапах разработки и производства наши партнеры могут получить квалифицированную поддержку опытных инженеров.

Система менеджмента качества компании отвечает требованиям в соответствии с ГОСТ Р ИСО 9001, ГОСТ РВ 0015-002 и ЭС РД 009

Офис по работе с юридическими лицами:

105318, г.Москва, ул.Щербаковская д.3, офис 1107, 1118, ДЦ «Щербаковский»

Телефон: +7 495 668-12-70 (многоканальный)

Факс: +7 495 668-12-70 (доб.304)

E-mail: info@moschip.ru

Skype отдела продаж:

moschip.ru

moschip.ru_4

moschip.ru_6

moschip.ru_9