

Ordering Information⁽¹⁾

Part Number	Package Type	Operating Range	Package Marking	Lead Finish
SM840001KA	K-8	-40°C to +75°C	840001	NiPdAu
SM840001KA TR ⁽²⁾	K-8	-40°C to +75°C	840001	NiPdAu

Note:

1. Devices are Green, RoHS-compliant and PFOS-compliant.
2. Tape and Reel.

Pin Configuration

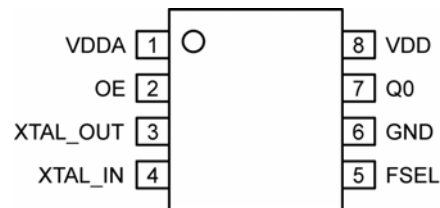

8-Pin TSSOP (K-8)

Pin Description

Pin Number	Pin Name	Type	Level	Pin Function
1	VDDA	P		Analog Power.
2	OE	I	Pull-up	Output Enable: 1 = Enable, 0 = Disable.
3	XTAL OUT	O		Crystal Out.
4	XTAL IN	I		Crystal Input.
5	FSEL	I	Pull-down	Frequency Select Pin.
6	GND	P		Ground.
7	Q0	O		Single Ended LVCMOS Clock Out.
8	VDD	P		Core Power.

Frequency Select Table

FSEL	Output (MHz)
0	106.25 (Default)
1	212.5

Output Enable

OE	Output
0	Disable
1	Enable

Absolute Maximum Ratings⁽¹⁾

Supply Voltage (V_{DD})	+4.6V
Input Voltage (V_{IN})	-0.50V to $V_{DD}+0.5V$
Output Voltage (V_{OUT})	-0.50V to $V_{DD}+0.5V$
Lead Temperature (soldering, 20sec.)	260°C
Storage Temperature (T_s)	-65°C to +150°C

Operating Ratings⁽²⁾

Supply Voltage (V_{IN})	+2.375V to +3.465V
Ambient Temperature (T_A)	-40°C to +75°C
Junction Thermal Resistance	
TSSOP (θ_{JA})	150°C/W

DC Electrical Characteristics

$V_{DD} = 2.5V \pm 5\%$; $T_A = -40^\circ C$ to $+75^\circ C$, unless noted.

Symbol	Parameter	Condition	Min	Typ	Max	Units
V_{DD}	Core Supply Voltage		2.375	2.50	2.625	V
V_{DDA}	Analog Supply Voltage		2.375	2.50	2.625	V
I_{DD}	Core Supply Current	No load		12	20	mA
I_{DDA}	Analog Supply Current			48	55	mA

DC Electrical Characteristics

$V_{DD} = 3.3V \pm 5\%$; $T_A = -40^\circ C$ to $+75^\circ C$, unless noted.

Symbol	Parameter	Condition	Min	Typ	Max	Units
V_{DD}	Core Supply Voltage		3.135	3.30	3.465	V
V_{DDA}	Analog Supply Voltage		3.135	3.30	3.465	V
I_{DD}	Core Supply Current	No load		15	22	mA
I_{DDA}	Analog Supply Current			49	55	mA

LVC MOS DC Characteristics

$V_{DD} = 2.5V$ and $3.3V \pm 5\%$; $T_A = -40^\circ C$ to $+75^\circ C$, unless noted.

Symbol	Parameter	Condition	Min	Typ	Max	Units
V_{IH}	Input HIGH Voltage	$V_{DD} = 3.3V \pm 5\%$	2		$V_{DD} + 0.3$	V
		$V_{DD} = 2.5V \pm 5\%$	1.7		$V_{DD} + 0.3$	V
V_{IL}	Input LOW Voltage	$V_{DD} = 3.3V \pm 5\%$	-0.30		0.80	V
		$V_{DD} = 2.5V \pm 5\%$	-0.30		0.70	V
V_{OH}	Output HIGH Voltage	$V_{DD} = 3.3V \pm 5\%$	2.6			V
		$V_{DD} = 2.5V \pm 5\%$	1.8			V
V_{OL}	Output LOW Voltage				0.5	V
I_{IH}	Input HIGH Current	Output Enable input			5	μA
I_{IL}	Input LOW Current	Output Enable input	-150			μA
I_{IH}	Input HIGH Current	FSEL input			150	μA
I_{IL}	Input LOW Current	FSEL input	-5			μA

Notes:

- Exceeding the absolute maximum rating may damage the device.
- The device is not guaranteed to function outside its operating rating.

AC Electrical Characteristics

$V_{DD} = 2.5V$ and $3.3V \pm 5\%$; $T_A = -40^\circ C$ to $+75^\circ C$, unless noted.

Symbol	Parameter	Condition	Min	Typ	Max	Units
F _{OUT}	Output Frequency	FSEL=1	186.66	212.5	226.66	MHz
		FSEL=0	93.33	106.25	113.33	MHz
t _{JITTER}	RMS Phase Jitter	106.25MHz, Integration Range: 637kHz to 10MHz		510		fs
		212.50MHz Integration Range: 2.55MHz to 20MHz		320		fs
t _R / t _F	Output Rise/Fall Time	20% to 80%	100		350	ps
ODC	Output Duty Cycle	106.25MHz	48		52	%
		212.50MHz	45		55	%

3.3V Carrier Frequency, 106.25MHz

Offset from Carrier	Measured Phase Noise	Unit
100Hz	-97	dBc/Hz
1kHz	-122	dBc/Hz
10kHz	-131	dBc/Hz
100kHz	-126	dBc/Hz
1MHz	-144	dBc/Hz
10MHz	-163	dBc/Hz
40MHz	-165	dBc/Hz

3.3V Carrier Frequency, 212.5MHz

Offset from Carrier	Measured Phase Noise	Unit
100Hz	-92	dBc/Hz
1kHz	-116	dBc/Hz
10kHz	-124	dBc/Hz
100kHz	-120	dBc/Hz
1MHz	-138	dBc/Hz
10MHz	-161	dBc/Hz
40MHz	-163	dBc/Hz

Crystal Characteristics

Parameter	Condition	Min	Typ	Max	Units
Mode of Oscillation		Fundamental Parallel Resonant			
Frequency			26.5625		MHz
Equivalent Series Resistance (ESR)				50	Ω
Shunt Capacitor				7	pF
Drive Level				1	mW

Functional Description

The SM840001 provides a high performance and high accuracy solution for a precision clock source at 106.25 or 212.50MHz derived from a low cost 26.5625MHz Xtal. A single 12mA LVCMOS output is provided with tri state capability, controlled via an external pin (OE).

The design of the SM840001 consumes very low power in the PLL due to a patented technology in the VCO and the associated dividers. The VCO range is ~3.2GHz to 3.5GHz providing high resolution and easy integer divide

ratios. Output Divider ratios are fixed at either +15 or +30 controlled via the FSEL pin, and the feedback divider also fixed at +120. Duty Cycle is inherently improved and guarantees tight control and stability on this critical specification. The provides improved specifications for Duty Cycle, Jitter, Phase Noise, Power Consumption, and noise sensitivity. Additionally, the SM840001 will operate at either 3.3V or 2.5V supplies.

Switching Waveforms

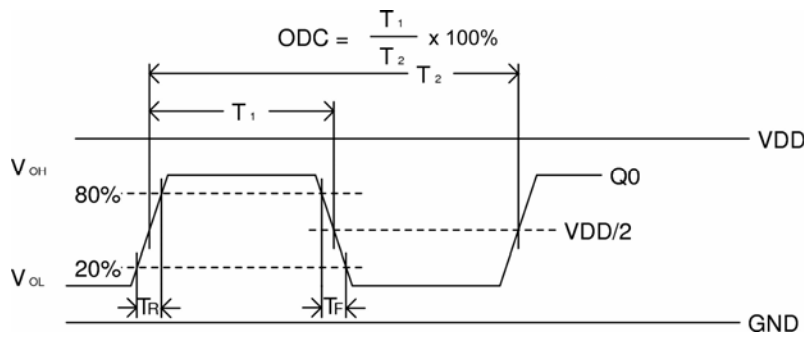

RMS Phase Noise/Jitter

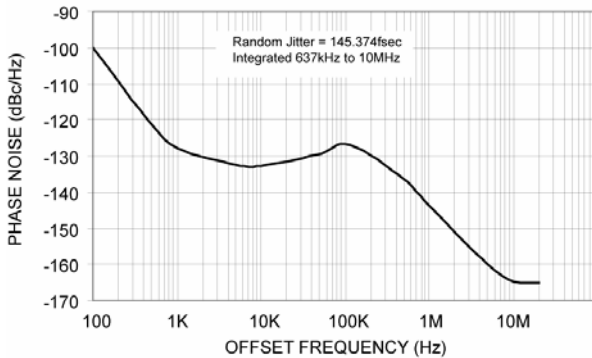

Phase Noise Plot: 106.25MHz @ 3.3V

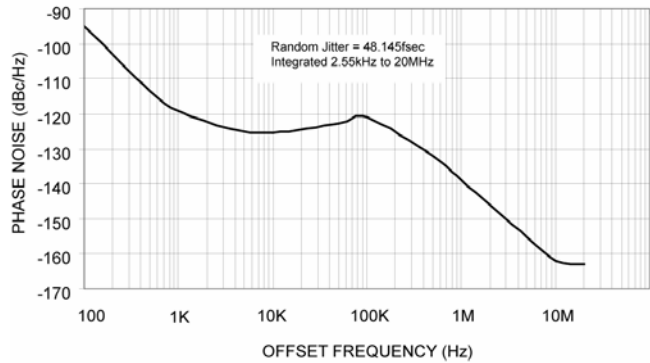

Phase Noise Plot: 212.5MHz @ 3.3V

Power Supply Filtering

The SM840001 provides separate power supply pins to isolate any high switching noise from outputs to internal core blocks. VDD and VDDA should be individually connected to the power plane through vias. Bypass capacitors should be used for each pin. Figure 2 illustrates how the power supply filter for 3.3V and 2.5V is configured.

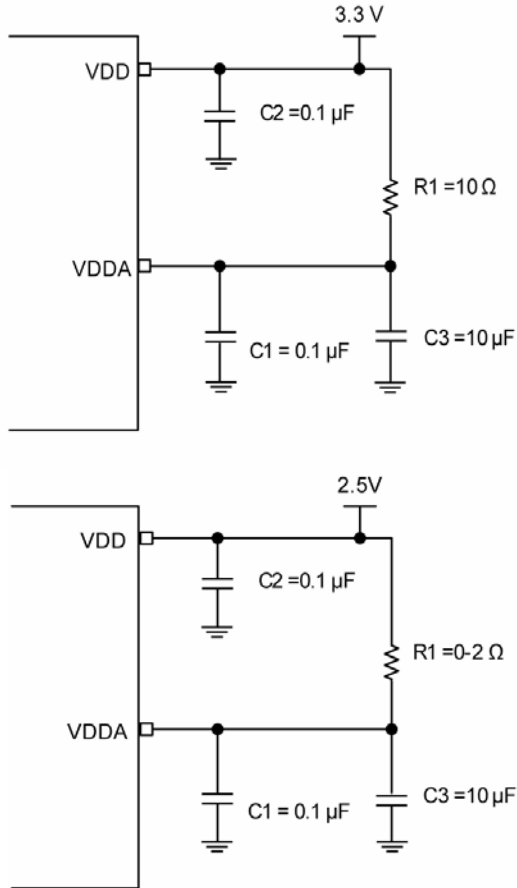
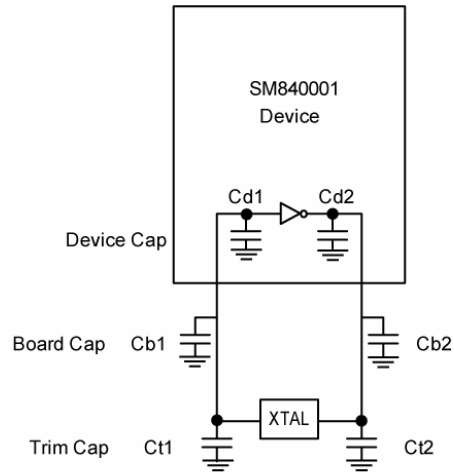

Figure 2.

Crystal Loading



Crystal Recommendations

This device requires a parallel resonance crystal. Substituting a series resonance crystal will cause this device to operate at the wrong frequency and violate the ppm specifications.

To achieve low ppm error, the total capacitance of the crystal must be considered in order to calculate appropriate capacitive loading (CL).

Load Capacitance at each side: Trim Capacitance = $C_t = (2 \cdot CL - (C_b + C_d))$

CL: Crystal load capacitance. Defined by manufacturer

Ct: External trim capacitors. (Trimmed CL Load capacitance to get the right ppm)

Cb: Board capacitance (vias, traces, etc.)

Cd: Internal capacitance of the device (lead frame, bond wires, pin, etc.)

Equivalent Series Resistance (ESR) Max.	Cut	Load Cap.	Shunt Cap. Max.	Drive Max.
50Ω	AT	18pF	7pF	0.1mW

Crystal Input Interface

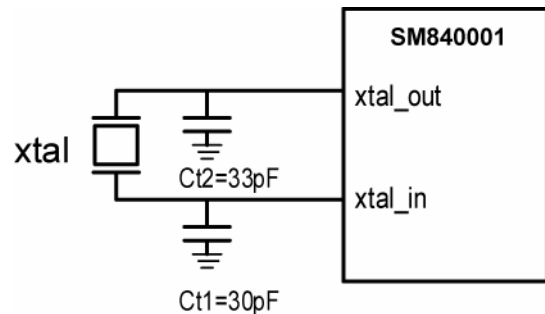

Total capacitance seen by crystal = $CL =$

$$\frac{1}{\frac{1}{(Ct1 + Cb1 + Cd1)} + \frac{1}{(Ct2 + Cb2 + Cd2)}}$$

Example:

$CL = 18pF, Cb = 2pF, Cd = 4pF$

Trim Cap = $Ct = 2 (18pF) - (2pF + 4pF) = 30pF$

The SM843022 has been characterized with 25MHz, 18pF parallel resonant crystal. The trim capacitors Ct1 and Ct2 were optimized to minimize the ppm error.

To minimize the board capacitance, a short trace from pin to crystal footprint without vias is desirable. It is preferable to have ground shielding or distance between the crystal traces and noisy signals on the board.

Board Layout

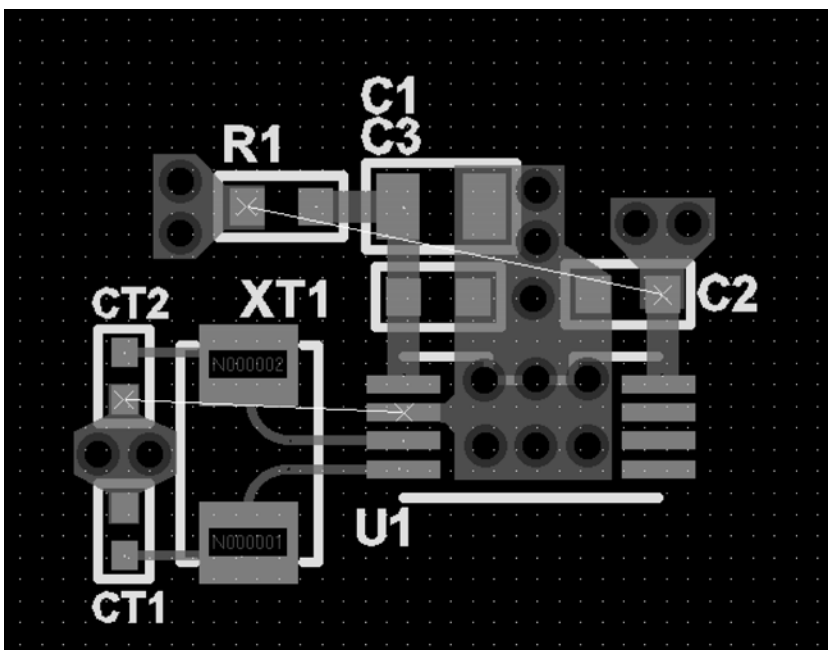

Package Information

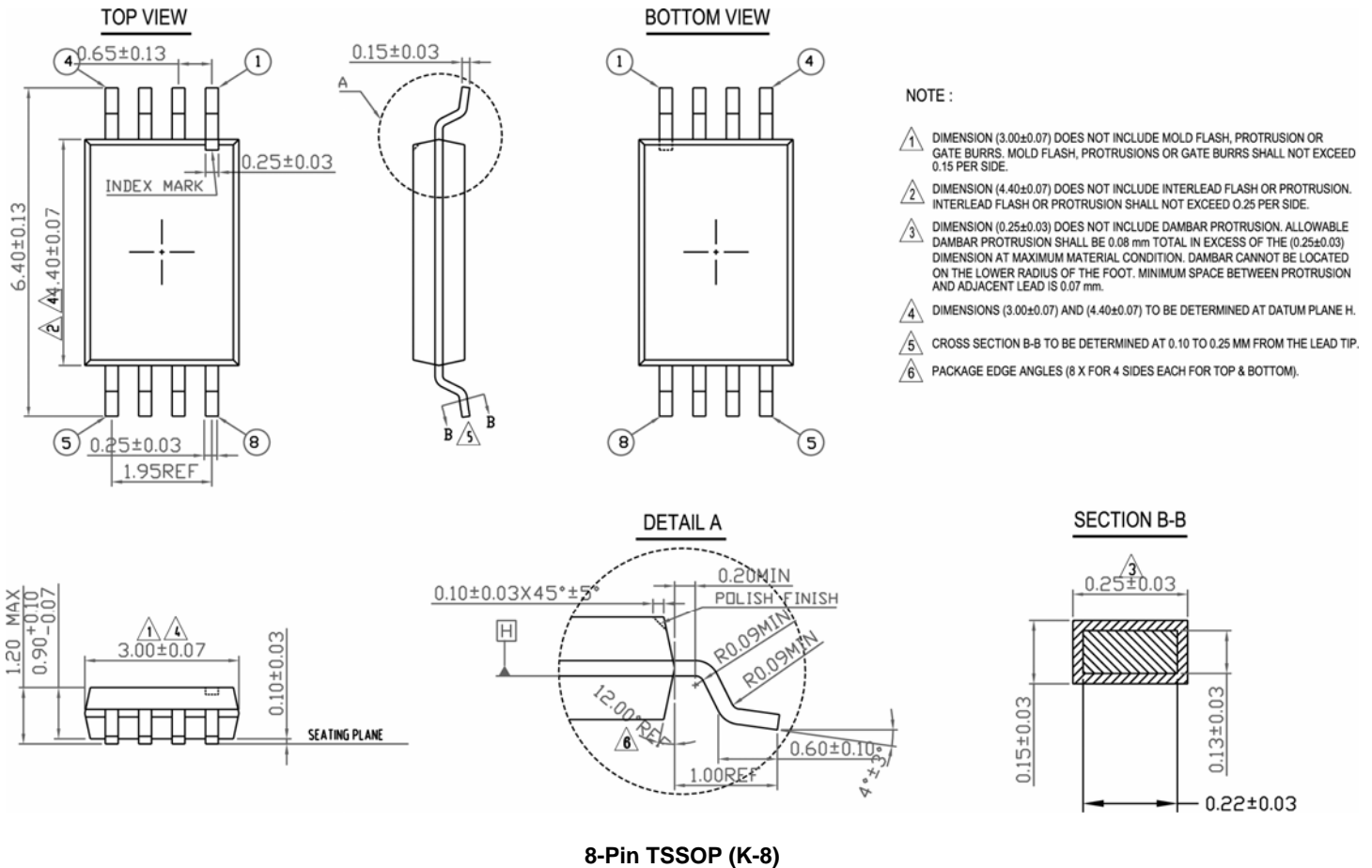

MICREL, INC. 2180 FORTUNE DRIVE SAN JOSE, CA 95131 USA
 TEL +1 (408) 944-0800 FAX +1 (408) 474-1000 WEB <http://www.micrel.com>

The information furnished by Micrel in this data sheet is believed to be accurate and reliable. However, no responsibility is assumed by Micrel for its use. Micrel reserves the right to change circuitry and specifications at any time without notification to the customer.

Micrel Products are not designed or authorized for use as components in life support appliances, devices or systems where malfunction of a product can reasonably be expected to result in personal injury. Life support devices or systems are devices or systems that (a) are intended for surgical implant into the body or (b) support or sustain life, and whose failure to perform can be reasonably expected to result in a significant injury to the user. A Purchaser's use or sale of Micrel Products for use in life support appliances, devices or systems is a Purchaser's own risk and Purchaser agrees to fully indemnify Micrel for any damages resulting from such use or sale.

© 2010 Micrel, Incorporated.

Данный компонент на территории Российской Федерации

Вы можете приобрести в компании MosChip.

Для оперативного оформления запроса Вам необходимо перейти по данной ссылке:

<http://moschip.ru/get-element>

Вы можете разместить у нас заказ для любого Вашего проекта, будь то серийное производство или разработка единичного прибора.

В нашем ассортименте представлены ведущие мировые производители активных и пассивных электронных компонентов.

Нашей специализацией является поставка электронной компонентной базы двойного назначения, продукции таких производителей как XILINX, Intel (ex.ALTERA), Vicor, Microchip, Texas Instruments, Analog Devices, Mini-Circuits, Amphenol, Glenair.

Сотрудничество с глобальными дистрибьюторами электронных компонентов, предоставляет возможность заказывать и получать с международных складов практически любой перечень компонентов в оптимальные для Вас сроки.

На всех этапах разработки и производства наши партнеры могут получить квалифицированную поддержку опытных инженеров.

Система менеджмента качества компании отвечает требованиям в соответствии с ГОСТ Р ИСО 9001, ГОСТ РВ 0015-002 и ЭС РД 009

Офис по работе с юридическими лицами:

105318, г.Москва, ул.Щербаковская д.3, офис 1107, 1118, ДЦ «Щербаковский»

Телефон: +7 495 668-12-70 (многоканальный)

Факс: +7 495 668-12-70 (доб.304)

E-mail: info@moschip.ru

Skype отдела продаж:

moschip.ru

moschip.ru_4

moschip.ru_6

moschip.ru_9