



## FEATURES

- Self-powered, only two connections required
- +4.50-19.99Vdc, +8.0-50.0Vdc, +30.0-199.9Vdc and +30-264Vdc models
- Ideal replacements for analog panel meters
- Ultra-low power consumption (8mA typ.)
- 0.37"/9.4mm high, red or blue, LED displays
- Subminiature 1.38" x 0.88" x 1.0" packages
- Super reliable, epoxy-encapsulated, construction

## Functional Specifications

### Input

#### Voltage Range: ①

DMS-20PC-0-DCM	+4.50 to +19.99Vdc
DMS-20PC-1-DCM	+8.0 to +50.0Vdc
DMS-20PC-2-DCM	+30 to +264Vdc
DMS-20PC-8-DCM	+30.0 to +199.9Vdc

#### Current Consumption:

DMS-20PC-0/1-DCM	13mA (max.)
DMS-20PC-2/8-DCM	7mA (max.)

### Performance

#### Sampling Rate

2.5 readings/second

#### Resolution:

DMS-20PC-0-DCM	±0.01V
DMS-20PC-1/8-DCM	±0.1V
DMS-20PC-2-DCM	±1V

#### Accuracy @ +25°C:

DMS-20PC-0-DCM	±0.01V (typ.), ±0.03V (max.)
DMS-20PC-1/8-DCM	±0.1V (typ.), ±0.2V (max.)
DMS-20PC-2-DCM	±1V (typ.), ±2V (max.)

### Mechanical

<b>Dimensions</b>	1.38" x 0.88" x 1.00"
<b>Display Type</b>	3 & 3½ digit, LED, 0.37"/9.4mm
<b>Weight</b>	1 ounce (28 grams)
<b>Case Material</b>	Polycarbonate
<b>6-32 screw torque</b>	6-8 in-lb (0.7 – 0.9N-m)

### Environmental

<b>Operating Temperature</b>	-25 to +60°C
<b>Storage Temperature</b>	-40 to +75°C
<b>Humidity (Non-condensing)</b>	0 to 95%

① Operation and accuracy at inputs above or below these ranges are not specified.

DATEL's DMS-20PC-DCM Series of self-powered, positive-reading, dc voltage monitors are great replacements for older, hard-to-read, analog panel meters. Simply connect a positive dc voltage across the rear terminals and the meters are fully operational — no additional components or power supplies are required! The large, 0.37"/9.4mm, LED displays can be easily read from 15 feet away. Four versions are available: +4.50-19.99Vdc (0.01V resolution), +8.0-50.0Vdc (0.1V resolution), +30.0-199.9Vdc (0.1V resolution) and +30-264Vdc (1V resolution). Built-in reverse polarity protection assures simple, trouble-free installation.

All DMS-20PC-DCM's employ a high-resolution, 3½ digit A/D converter and precision metal-film resistors to achieve outstanding performance over an operating temperature range of -25 to +60°C. A rugged, epoxy-encapsulated, polycarbonate case provides excellent protection against moisture, shock and vibration. The DMS-20PC-DCM's are designed to fit the same panel cutout as DATEL's popular DMS-20PC-X-LM ac-line voltage monitors

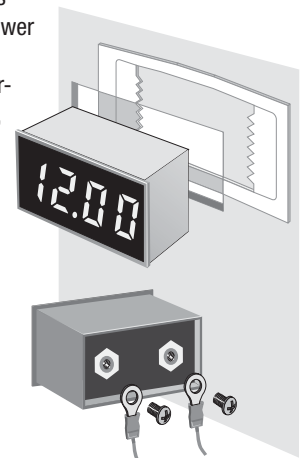

Typical panel mount installation and suggested wiring (user supplied).

## Ordering Information

<b>DMS-20PC-0-DCM-C</b>	+4.50 to +19.99V dc red LED voltage monitor
<b>DMS-20PC-0-DCM-B-C</b>	+4.50 to +19.99V blue LED dc voltage monitor
<b>DMS-20PC-0-DCM-G-C</b>	+4.50 to +19.99V green LED dc voltage monitor
<b>DMS-20PC-1-DCM-C</b>	+8.0 to +50.0V red LED dc voltage monitor
<b>DMS-20PC-1-DCM-B-C</b>	+8.0 to +50.0V blue LED dc voltage monitor
<b>DMS-20PC-1-DCM-G-C</b>	+8.0 to +50.0V green LED dc voltage monitor
<b>DMS-20PC-2-DCM-C</b>	+30 to +264V dc voltage monitor
<b>DMS-20PC-8-DCM-C</b>	+30.0 to +199.9V dc voltage monitor
<b>DMS-20-CP</b>	Panel cutout punch
<b>DMS-BZL3-C</b>	Panel mount bezel assembly
<b>DMS-BZL4-C</b>	Panel mount bezel with sealing gasket

Brass screws (6-32 thread) and a panel-mount retaining clip are supplied with each meter



## MECHANICAL SPECIFICATIONS

Dimensions in inches (millimeters)  
 Tolerances: 2 PL Dec  $\pm 0.02$  ( $\pm 0.51$ )  
 3 PL Dec  $\pm 0.010$  ( $\pm 0.254$ )  
 Recommended panel cutout dimensions:  
 1.336 (33.93)W  $\times$  0.838 (21.29)H  
 Internal corner radii 0.032 (0.81) Max.

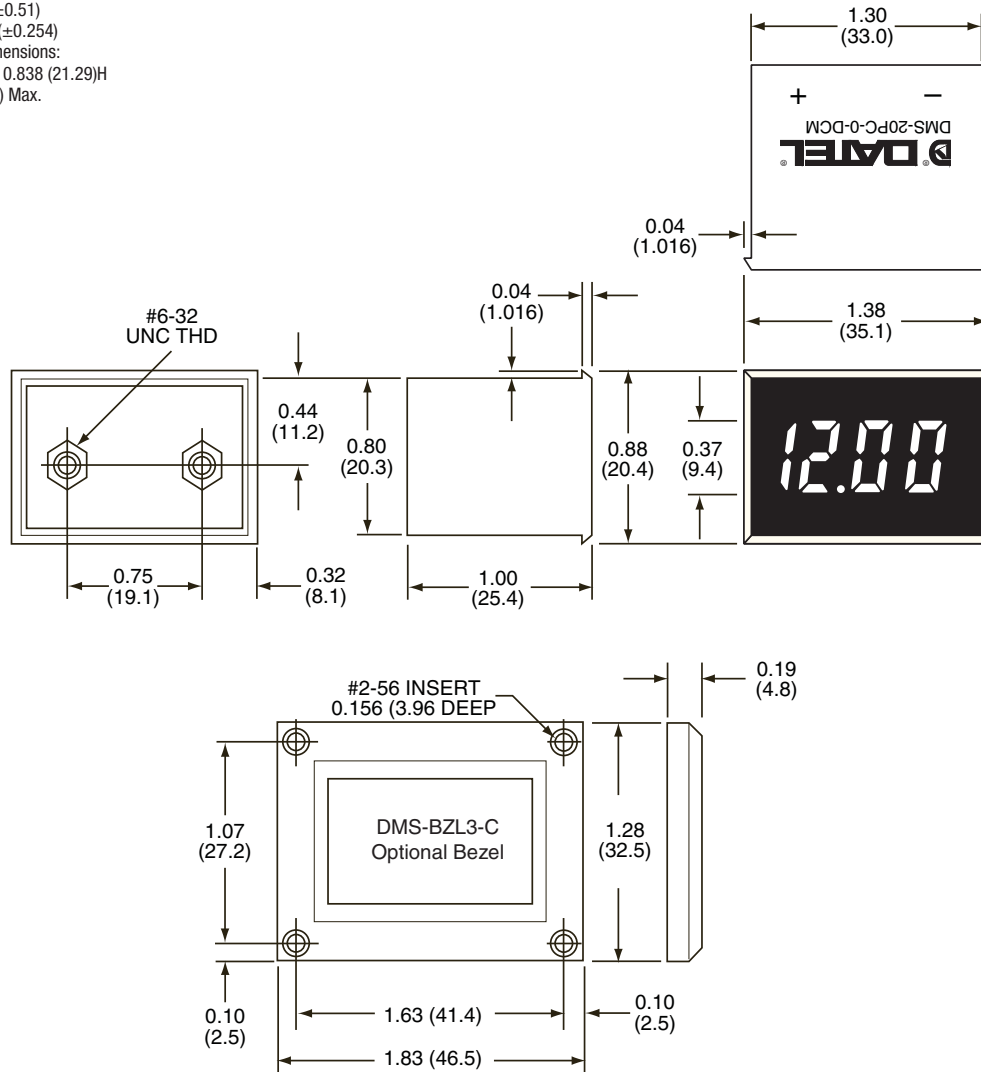

Murata Power Solutions, Inc.  
 11 Cabot Boulevard, Mansfield, MA 02048-1151 U.S.A.  
 ISO 9001 and 14001 REGISTERED

Murata Power Solutions, Inc. makes no representation that the use of its products in the circuits described herein, or the use of other technical information contained herein, will not infringe upon existing or future patent rights. The descriptions contained herein do not imply the granting of licenses to make, use, or sell equipment constructed in accordance therewith. Specifications are subject to change without notice.  
 © 2012 Murata Power Solutions, Inc.

## Данный компонент на территории Российской Федерации

### Вы можете приобрести в компании MosChip.

Для оперативного оформления запроса Вам необходимо перейти по данной ссылке:

<http://moschip.ru/get-element>

Вы можете разместить у нас заказ для любого Вашего проекта, будь то серийное производство или разработка единичного прибора.

В нашем ассортименте представлены ведущие мировые производители активных и пассивных электронных компонентов.

Нашей специализацией является поставка электронной компонентной базы двойного назначения, продукции таких производителей как XILINX, Intel (ex.ALTERA), Vicor, Microchip, Texas Instruments, Analog Devices, Mini-Circuits, Amphenol, Glenair.

Сотрудничество с глобальными дистрибьюторами электронных компонентов, предоставляет возможность заказывать и получать с международных складов практически любой перечень компонентов в оптимальные для Вас сроки.

На всех этапах разработки и производства наши партнеры могут получить квалифицированную поддержку опытных инженеров.

Система менеджмента качества компании отвечает требованиям в соответствии с ГОСТ Р ИСО 9001, ГОСТ РВ 0015-002 и ЭС РД 009

### Офис по работе с юридическими лицами:

105318, г.Москва, ул.Щербаковская д.3, офис 1107, 1118, ДЦ «Щербаковский»

Телефон: +7 495 668-12-70 (многоканальный)

Факс: +7 495 668-12-70 (доб.304)

E-mail: [info@moschip.ru](mailto:info@moschip.ru)

Skype отдела продаж:

moschip.ru

moschip.ru\_4

moschip.ru\_6

moschip.ru\_9