



# TPP25011

Application Specific Discretes  
A.S.D.<sup>TM</sup>

OVERVOLTAGE and OVERCURRENT  
PROTECTION for TELECOM LINE

## FEATURES

- UNIDIRECTIONAL FUNCTION
- PROGRAMMABLE BREAKDOWN VOLTAGE  
UP TO 250 V
- PROGRAMMABLE CURRENT LIMITATION  
FROM 40 mA TO 500 mA
- SURGE CURRENT CAPABILITY  
 $I_{PP} = 30A \quad 10/1000 \mu s$

## DESCRIPTION

Dedicated to sensitive telecom equipment protection, this device can provide both voltage and current triggered protection with a very tight tolerance. The breakdown voltage can be easily programmed by using an external zener diode.

A multiple protection mode can be also performed when using several zener diodes, providing to each line interface an optimized protection level. The current limiting function is achieved with the use of a resistor between the gate and the cathode. The value of the resistor will determine the level of the desired current.

## COMPLIES WITH THE FOLLOWING STANDARDS :

<b>CCITT K17 :</b>	10/700	$\mu s$	1.5 kV
	5/310	$\mu s$	38 A
<b>VDE 0433 :</b>	10/700	$\mu s$	2k V
	5/310	$\mu s$	40 A (*)
<b>CNET :</b>	0.5/700	$\mu s$	1.5 kV
	0.2/310	$\mu s$	38 A
<b>FCC part 68 :</b>	2/10	$\mu s$	2.5 kV
	2/10	$\mu s$	75 A (*)
<b>BELLCORE TR-NWT-000974 :</b>	10/1000	$\mu s$	1 kV
	10/1000	$\mu s$	30 A (*)

(\*) with series resistors or PTC.

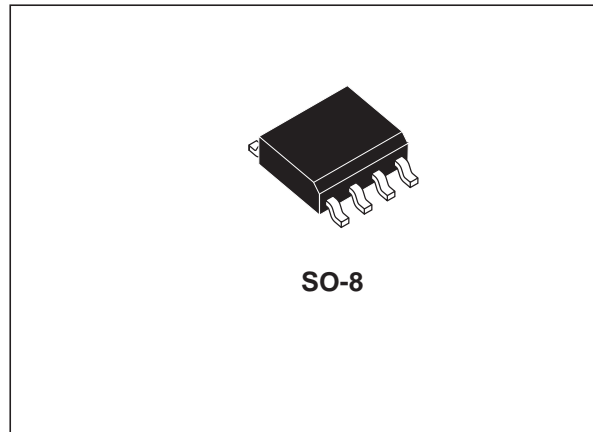

## SCHEMATIC DIAGRAM

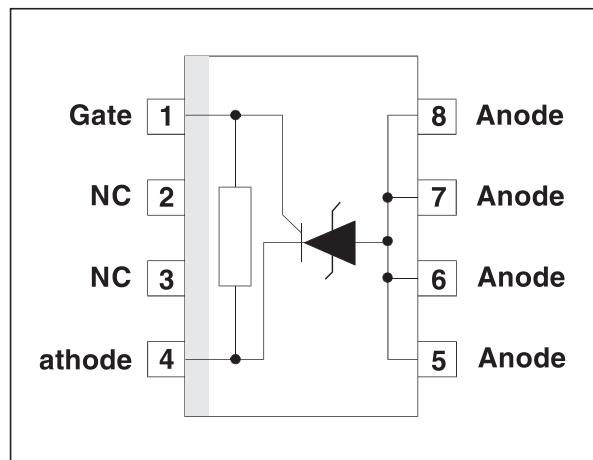

TM: ASD is trademarks of STMicroelectronics.

## TPP25011

### ABSOLUTE MAXIMUM RATINGS ( $T_{amb} = 25\text{ }^{\circ}\text{C}$ )

Symbol	Parameter		Value	Unit
$I_{PP}$	Peak pulse current (see note 1)	10/1000 $\mu\text{s}$	30	A
		5/310 $\mu\text{s}$	40	
		2/10 $\mu\text{s}$	75	
$I_{TSM}$	Non repetitive surge peak on-state current ( $F = 50\text{Hz}$ )	$t_p = 10\text{ms}$ $t = 1\text{s}$	5 3.5	A
$T_{stg}$ $T_j$	Storage temperature range Maximum junction temperature		- 55 to + 150 150	$^{\circ}\text{C}$

**Note 1 :** Pulse waveform :

10/1000 $\mu\text{s}$	$t_r = 10\mu\text{s}$	$t_p = 1000\mu\text{s}$
5/310 $\mu\text{s}$	$t_r = 5\mu\text{s}$	$t_p = 310\mu\text{s}$
2/10 $\mu\text{s}$	$t_r = 2\mu\text{s}$	$t_p = 10\mu\text{s}$

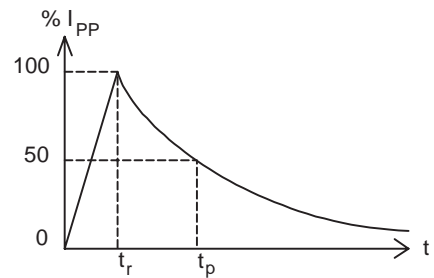

### THERMAL RESISTANCES

Symbol	Parameter	Value	Unit
$R_{th(j-a)}$	Junction to ambient	170	$^{\circ}\text{C/W}$

**ELECTRICAL CHARACTERISTICS** ( $T_{amb} = 25^{\circ}\text{C}$ )

Symbol	Parameter
$V_{RM}$	Stand-off voltage
$I_{RM}$	Leakage current at stand-off voltage
$V_{BR}$	Breakdown voltage
$V_{BO}$	Breakover voltage
$I_H$	Holding current
$I_{BO}$	Breakover current
$I_{PP}$	Peak pulse current
$V_{GN}$	Gate voltage
$I_G$	Gate triggering current
C	Capacitance

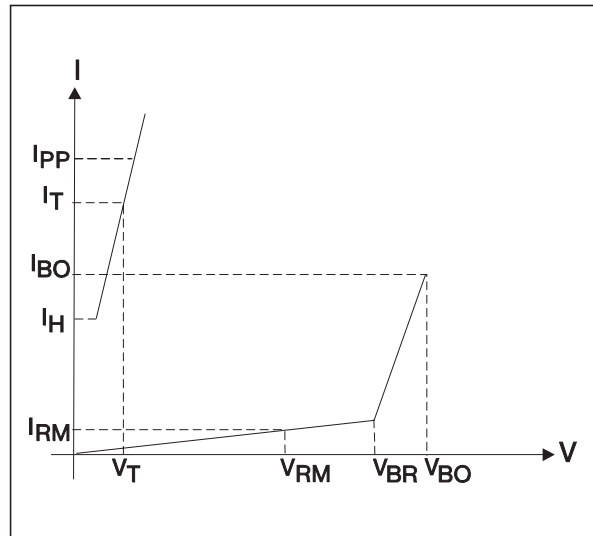

**1 - OPERATION WITHOUT GATE**

Type	$I_{RM} @ V_{RM}$ max.		$V_{BR} @ I_R$ min.		$V_{BO} @ I_{BO}$ max. min. note1 max.			$I_H$ min. note 2	C max. note 3
	$\mu\text{A}$	V	V	mA	V	mA	mA	mA	pF
TPP25011	6	60	250	1	340	15	200	180	100

**2 - OPERATION WITH GATE**

Type	$V_{GN} @ I_{GN} = 30 \text{ mA}$ min. max. note 4		$I_G$ min. max. $V_{A-C} = 100 \text{ V}$	
	V	V	mA	mA
TPP25011	1.05	1.35	5	40

**Note 1:** See the reference test circuit 1.

**Note 2:** See test circuit 2.

**Note 3:**  $V_R = 5\text{V}$ ,  $F = 1\text{MHz}$

REFERENCE TEST CIRCUIT 1 :

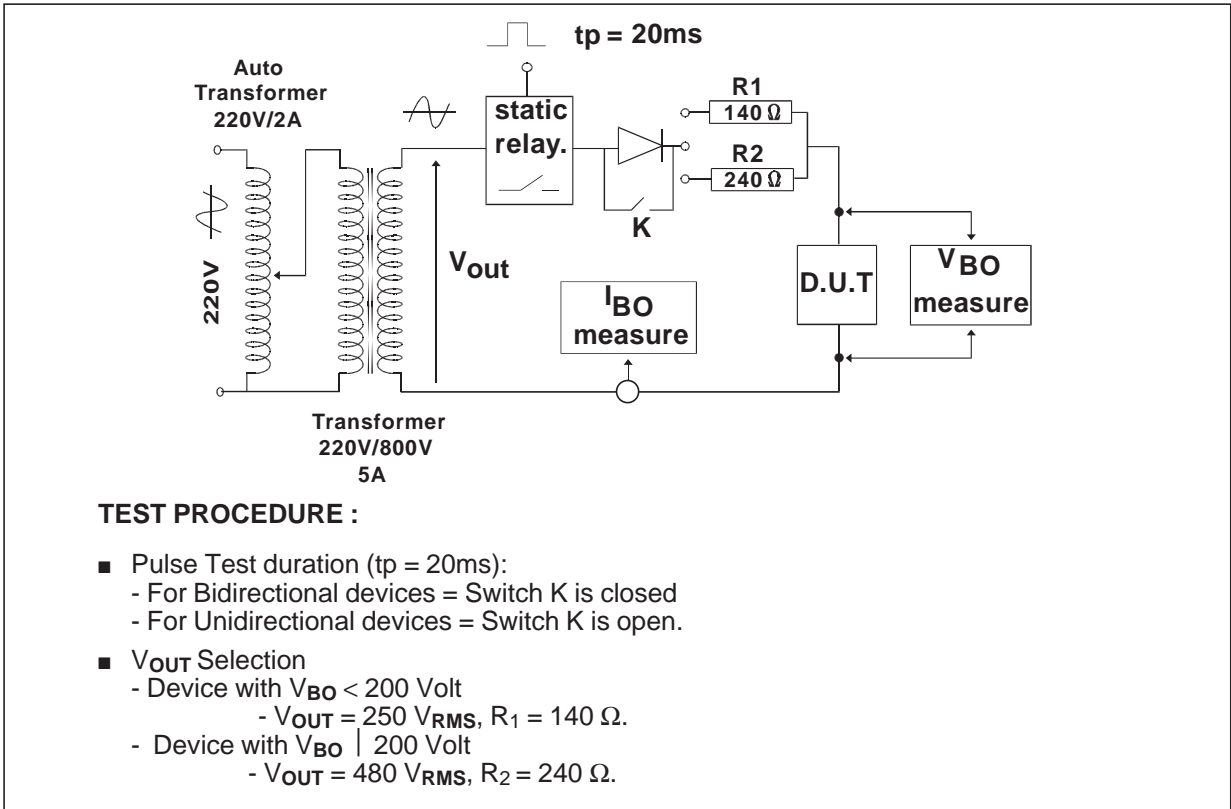

FUNCTIONAL HOLDING CURRENT (I<sub>H</sub>) TEST CIRCUIT 2 = GO - NOGO TEST

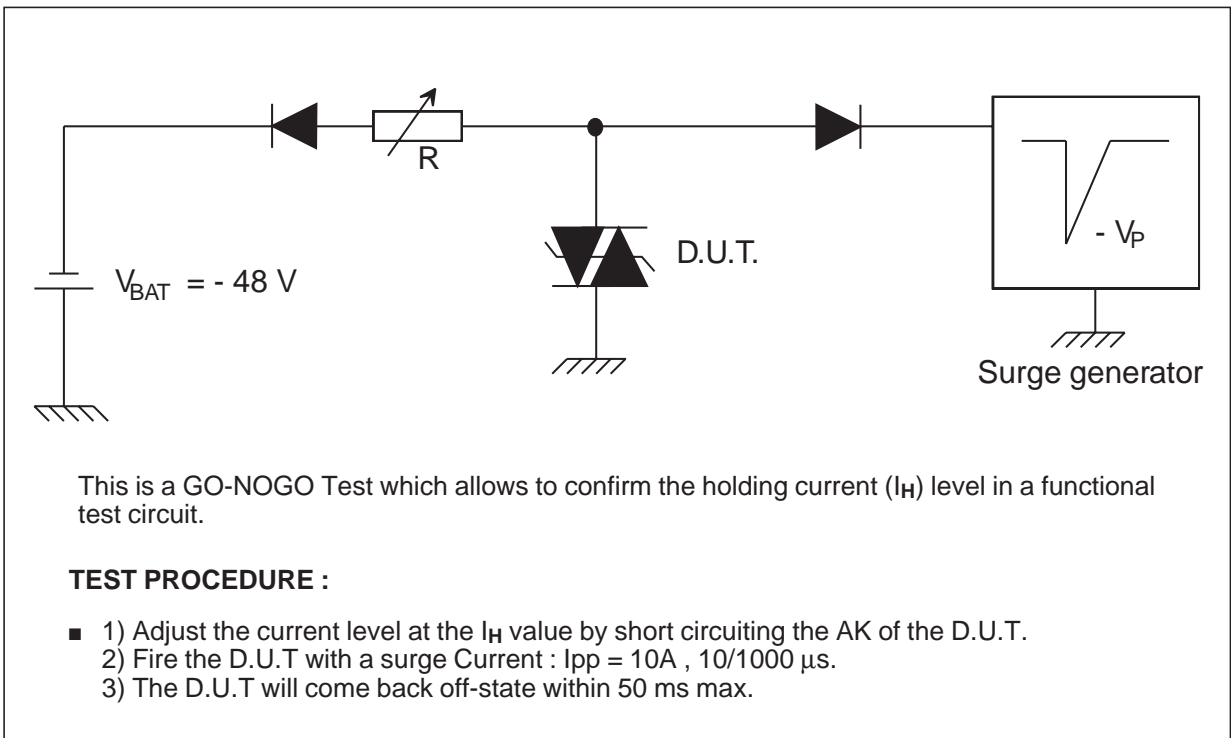

**APPLICATION CIRCUIT**  
**Overvoltage protection and current limitation**

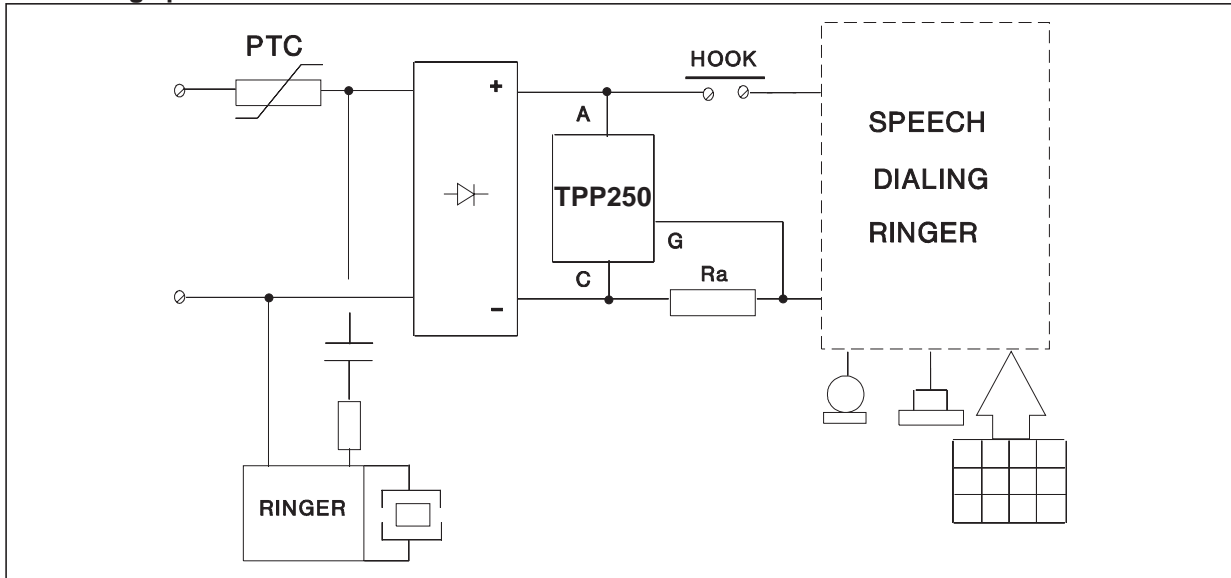
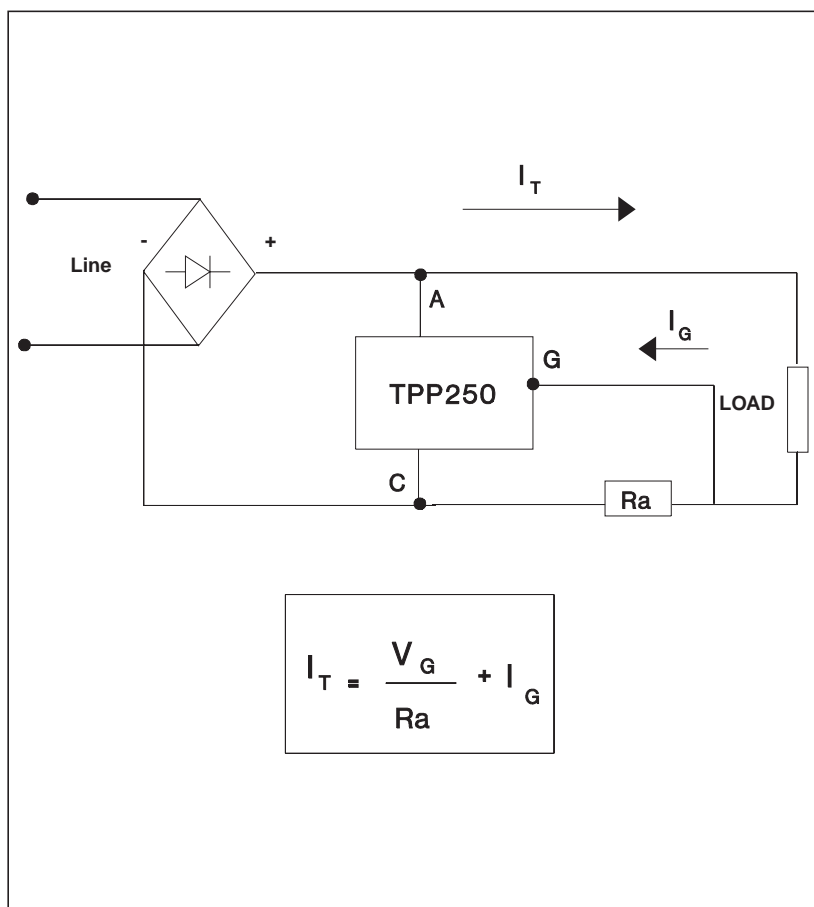

Table below gives the tolerance of the limited current  $I_T$  for each standardized resistor value.

CURRENT TOLERANCE		
R Ω ( ± 5%)	$I_T$ mA min	$I_T$ mA max
3.00	338	514
3.30	308	471
3.60	283	435
3.90	261	404
4.30	238	370
4.70	218	342
5.10	201	319
5.60	184	294
6.20	166	269
6.80	152	249
7.50	138	229
8.20	127	213
9.10	115	196
10.10	104	181
11.00	96	169
12.00	88	158
13.00	82	149
15.00	72	135
16.00	68	129
18.00	61	119
20.00	55	111
22.00	50	105
24.00	47	99
27.00	42	93
30.00	38	87



# TPP25011

## Telephone set protection

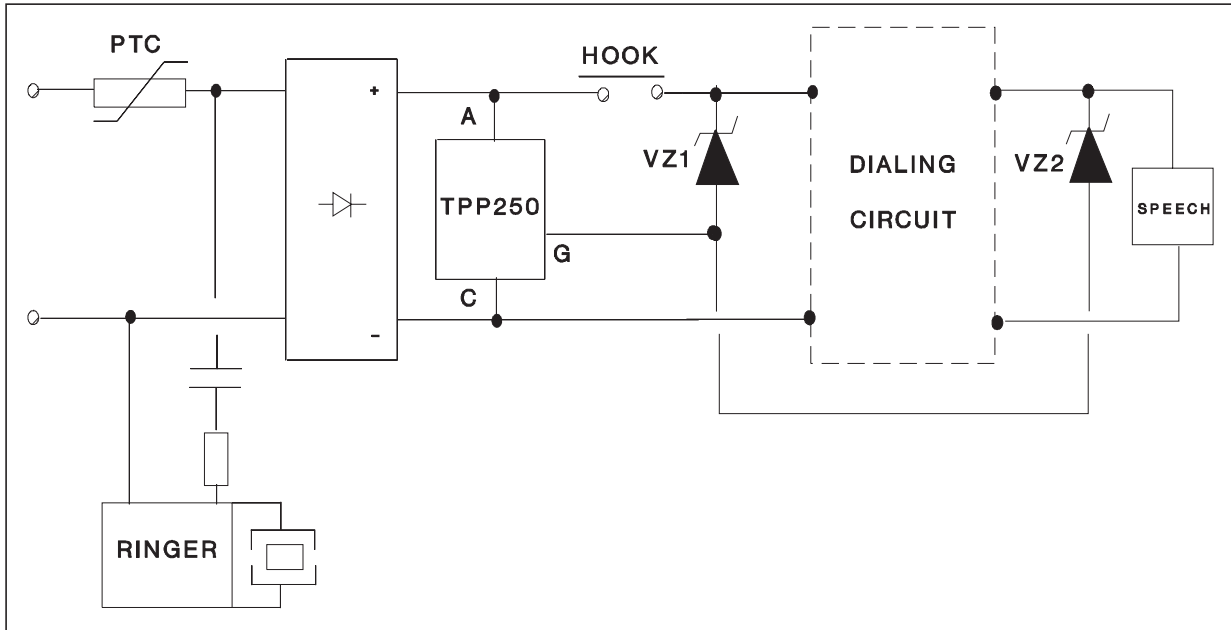

### PROTECTION MODES :

**OFF HOOK** = Ringer circuit protection is insured with intrinsic breakdown voltage at 250 V

**ON HOOK** = In dialing mode and in conversation mode, the breakdown voltage of TPP250 can be adapted at different levels with zener diodes.

### ORDER CODE

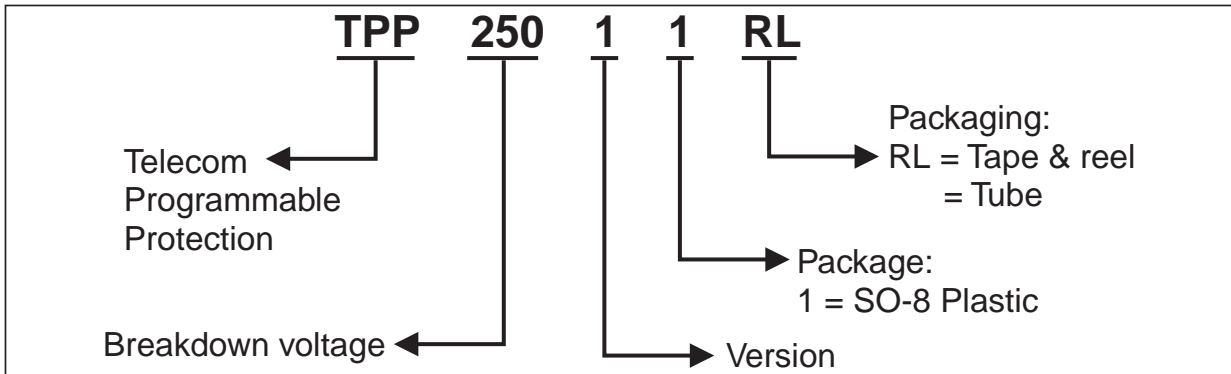

**MARKING**

Package	Type	Marking
SO-8	TPP25011	TPP250

**PACKAGE MECHANICAL DATA**  
SO-8 Plastic

REF.	DIMENSIONS					
	Millimetres			Inches		
	Min.	Typ.	Max.	Min.	Typ.	Max.
A			1.75			0.069
a1	0.1		0.25	0.004		0.010
a2			1.65			0.065
b	0.35		0.48	0.014		0.019
b1	0.19		0.25	0.007		0.010
C		0.50			0.020	
c1	45° (typ)					
D	4.8		5.0	0.189		0.197
E	5.8		6.2	0.228		0.244
e		1.27			0.050	
e3		3.81			0.150	
F	3.8		4.0	0.15		0.157
L	0.4		1.27	0.016		0.050
M			0.6			0.024
S	8° (max)					

**Packaging :** Products supplied antistatic tubes or tape and reel.

**Weight :**0.08g

Information furnished is believed to be accurate and reliable. However, STMicroelectronics assumes no responsibility for the consequences of use of such information nor for any infringement of patents or other rights of third parties which may result from its use. No license is granted by implication or otherwise under any patent or patent rights of STMicroelectronics. Specifications mentioned in this publication are subject to change without notice. This publication supersedes and replaces all information previously supplied. STMicroelectronics products are not authorized for use as critical components in life support devices or systems without express written approval of STMicroelectronics.

The ST logo is a registered trademark of STMicroelectronics.

All other names are the property of their respective owners.

© 2003 STMicroelectronics - All rights reserved.

STMicroelectronics GROUP OF COMPANIES

Australia - Belgium - Brazil - Canada - China - Czech Republic - Finland - France - Germany - Hong Kong - India - Israel - Italy - Japan - Malaysia - Malta - Morocco - Singapore - Spain - Sweden - Switzerland - United Kingdom - United States

[www.st.com](http://www.st.com)



## Данный компонент на территории Российской Федерации

### Вы можете приобрести в компании MosChip.

Для оперативного оформления запроса Вам необходимо перейти по данной ссылке:

<http://moschip.ru/get-element>

Вы можете разместить у нас заказ для любого Вашего проекта, будь то серийное производство или разработка единичного прибора.

В нашем ассортименте представлены ведущие мировые производители активных и пассивных электронных компонентов.

Нашей специализацией является поставка электронной компонентной базы двойного назначения, продукции таких производителей как XILINX, Intel (ex.ALTERA), Vicor, Microchip, Texas Instruments, Analog Devices, Mini-Circuits, Amphenol, Glenair.

Сотрудничество с глобальными дистрибьюторами электронных компонентов, предоставляет возможность заказывать и получать с международных складов практически любой перечень компонентов в оптимальные для Вас сроки.

На всех этапах разработки и производства наши партнеры могут получить квалифицированную поддержку опытных инженеров.

Система менеджмента качества компании отвечает требованиям в соответствии с ГОСТ Р ИСО 9001, ГОСТ РВ 0015-002 и ЭС РД 009

### Офис по работе с юридическими лицами:

105318, г.Москва, ул.Щербаковская д.3, офис 1107, 1118, ДЦ «Щербаковский»

Телефон: +7 495 668-12-70 (многоканальный)

Факс: +7 495 668-12-70 (доб.304)

E-mail: [info@moschip.ru](mailto:info@moschip.ru)

Skype отдела продаж:

moschip.ru

moschip.ru\_4

moschip.ru\_6

moschip.ru\_9