

Single-Turn Precision Potentiometer

Model 6670 Series



Features:

- 2" diameter
- Conductive plastic technology



Models Available

6671	1/4" Shaft, 3/8" Bushing
6673	1/4" Shaft, Servo

Electrical

Resistance Range	1K to 300K Ohms
Standard Resistance Tolerance	±10%
Minimum Practical Resistance Tolerance	±3%
Independent Linearity ²	±0.25%
Minimum Practical Independent Linearity	±0.1%
Input Voltage	400 VDC maximum, not to exceed power rating
Power Rating	3.5 Watts at 70°C, derating to 0 at 125°C
Dielectric Strength	1,000 V rms
Insulation Resistance	1,000 Megohms minimum
Output smoothness	0.1% maximum
Actual Electrical Travel	350° nominal
Electrical Continuity Travel	354° minimum
End Voltage	maximum 0.5% of input voltage
Tap Tolerance	maximum 0.5% of input voltage
Resolution	essentially infinite
Temperature Coefficient of Resistance ³	-400 ppm/°C typical
Temperature Coefficient of Output Voltage ⁴	±10 ppm/°C typical

Mechanical

Total Mechanical Travel	360° continuous
Number of Gangs	4 maximum
Weight	4.0 oz. single gang nominal, 1.5 oz. each added gang
Shaft Runout	maximum T.I.R. 0.001"
Pilot Diameter Runout	maximum T.I.R. 0.0015"
Lateral Runout	maximum T.I.R. 0.005"
Shaft Radial Play	maximum 0.002"
Start/Run Torque	maximum 1.5 / 1.0 oz.-in. per gang, ES option adds 0.5 oz.-in.

¹ Specifications subject to change without notice.

² Linearity is measured between 1% and 99% of input voltage.

³ Special TCR available to ±100 ppm/°C.

⁴ Measured with 10 VDC CW to CCW and slider at 50% of electrical travel.

General Note

TT Electronics reserves the right to make changes in product specification without notice or liability. All information is subject to TT Electronics' own data and is considered accurate at time of going to print.

© TT electronics plc

TT Electronics | BI Technologies
413 Rood RD, Suite 7
Calxico, CA 92231
Ph: +1 714 447 2345
www.ttelectronics.com/bi-technologies

Single-Turn Precision Potentiometer

Model 5311



Environmental

Operating Temperature Range	-40°C to +125°C dynamic, -65°C to +125°C static
Temperature Cycling	5 cycles, -65°C to +125°C, maximum 10% ΔR
Shock	6 ms Saw-tooth, 100 G's, 0.1 ms maximum discontinuity
Vibration	15 G's, 10 to 2,000 Hz, maximum 2% ΔR, 0.1 ms maximum discontinuity
Moisture Resistance	ten 24 hour cycles, maximum 10% ΔR
High Temperature Exposure	1,000 hours at 125°C, maximum 0.5% ΔR
Rotational Life	25 million shaft revolutions
Rotational Load Life	5 million shaft revolutions plus 900 hours at 3.5 Watts & 70°C, maximum 10% ΔR
Ingress Protection Rating (IP Code)	IP50, IP66 available as option for 6671 (feature code ES)

Ordering Information



FEATURE CODES

Center Tap	CT
Linearity Tape	LT
Flatted Shaft	FS
Slotted Shaft	SS
Rear Shaft Extension	RS
Shaft Lock, 6671 only	SL
Additional Gangs	2G, 3G, or 4G
Seal (IP66), 6671 only	ES

When multiple feature codes are used the P/N shall be in the same sequence as listed in this table (top to bottom).

CIRCUIT DIAGRAM



STANDARD RESISTANCE VALUES

1K	2K	5K	10K	20K	50K
----	----	----	-----	-----	-----

General Note
 TT Electronics reserves the right to make changes in product specification without notice or liability. All information is subject to TT Electronics' own data and is considered accurate at time of going to print.

TT Electronics | BI Technologies
 413 Rood RD, Suite 7
 Calexico, CA 92231
 Ph: +1 714 447 2345
www.ttelectronics.com/bi-technologies

Single-Turn Precision Potentiometer

Model 5311



Model 6671 Bushing Mount

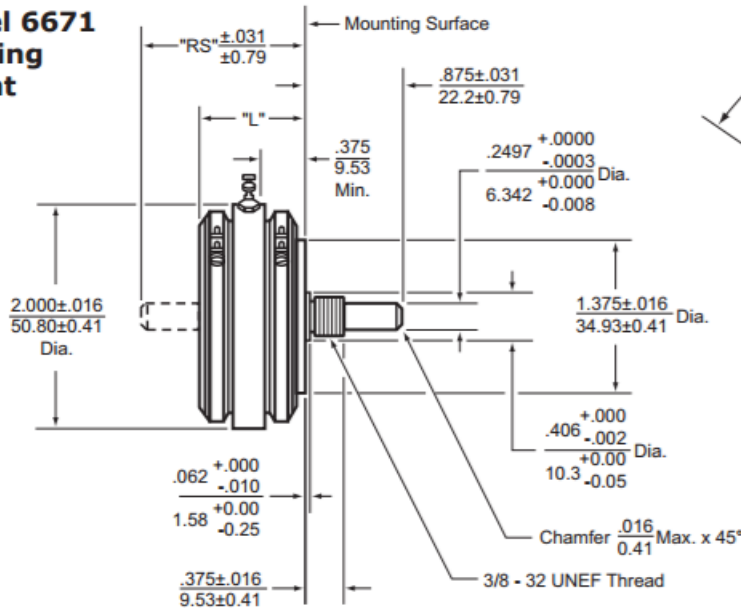

Dim. "L"	Dim. "RS"	No. of Gangs
$.905 \pm 0.020$ / 22.9 ± 0.51	1.405 / 35.69	1
1.467 ± 0.22 / 37.26 ± 0.56	1.967 / 49.96	2
2.029 ± 0.024 / 51.54 ± 0.61	2.529 / 64.24	3
2.591 ± 0.026 / 65.81 ± 0.66	3.091 / 78.51	4

Model 6673 Servo Mount

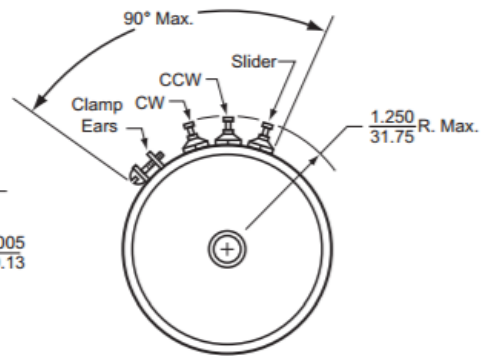
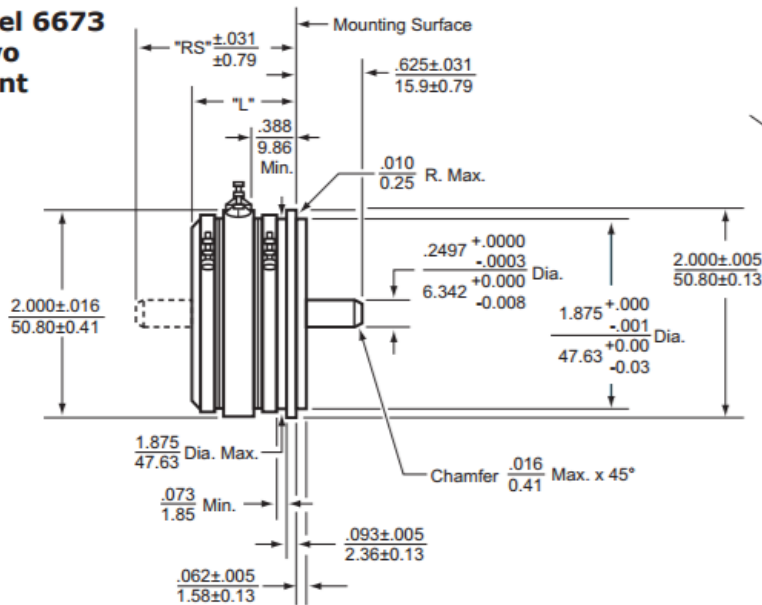

Dim. "L"	Dim. "RS"	No. of Gangs
1.020 ± 0.015 / 22.9 ± 0.51	1.405 / 35.69	1
1.467 ± 0.22 / 37.26 ± 0.56	1.967 / 49.96	2
2.029 ± 0.024 / 51.54 ± 0.61	2.529 / 64.24	3
2.591 ± 0.026 / 65.81 ± 0.66	3.091 / 78.51	4

General Note

TT Electronics reserves the right to make changes in product specification without notice or liability. All information is subject to TT Electronics' own data and is considered accurate at time of going to print.

© TT electronics plc

TT Electronics | BI Technologies
413 Rood RD, Suite 7
Calxico, CA 92231
Ph: +1 714 447 2345
www.ttelectronics.com/bi-technologies

Данный компонент на территории Российской Федерации

Вы можете приобрести в компании MosChip.

Для оперативного оформления запроса Вам необходимо перейти по данной ссылке:

<http://moschip.ru/get-element>

Вы можете разместить у нас заказ для любого Вашего проекта, будь то серийное производство или разработка единичного прибора.

В нашем ассортименте представлены ведущие мировые производители активных и пассивных электронных компонентов.

Нашей специализацией является поставка электронной компонентной базы двойного назначения, продукции таких производителей как XILINX, Intel (ex.ALTERA), Vicor, Microchip, Texas Instruments, Analog Devices, Mini-Circuits, Amphenol, Glenair.

Сотрудничество с глобальными дистрибьюторами электронных компонентов, предоставляет возможность заказывать и получать с международных складов практически любой перечень компонентов в оптимальные для Вас сроки.

На всех этапах разработки и производства наши партнеры могут получить квалифицированную поддержку опытных инженеров.

Система менеджмента качества компании отвечает требованиям в соответствии с ГОСТ Р ИСО 9001, ГОСТ РВ 0015-002 и ЭС РД 009

Офис по работе с юридическими лицами:

105318, г.Москва, ул.Щербаковская д.3, офис 1107, 1118, ДЦ «Щербаковский»

Телефон: +7 495 668-12-70 (многоканальный)

Факс: +7 495 668-12-70 (доб.304)

E-mail: info@moschip.ru

Skype отдела продаж:

moschip.ru

moschip.ru_4

moschip.ru_6

moschip.ru_9