

# AFBR-S10PS010Z and AFBR-S10PS011Z



## Point Sensor for Light Detection and Plastic Optical Fiber Connector for Point Sensor

### Data Sheet



---

### Description

AFBR-S10PS010Z is an optical point sensor with self-supervision functionality. The light that meets the point sensor is captured and fed into a plastic optical fiber (POF). The self-supervision functionality is achieved by an in-built coupling between two fibers. AFBR-S10PS011Z is a miniature connector used to connect a duplex POF cable to the point sensor. The special POF-based sensor design allows the system engineer to avoid any galvanic contact between the arc flash area and the detection electronics.

Both AFBR-S10PS010Z and AFBR-S10PS011Z are part of the Broadcom's comprehensive arc flash detection portfolio. In combination with Broadcom's sensor transceiver AFBR-S10TR001Z, they are intended to be used for the detection of arc flash events in electrical power grids.

### Features

- Light capturing through the translucent head of the point sensor
- Light coupling into a plastic optical fiber by means of the plastic optical fiber connector
- Optical link self-supervision supported (heartbeat signal)
- Low Halogen and RoHS compliance
- UL flammability UL94HB
- Good chemical resistance
- Operating temperature range  $-40^{\circ}\text{C}$  to  $85^{\circ}\text{C}$
- Acceptance cone exceeds  $180^{\circ}$  spherical with high homogeneity
- Suitable for 1.0/2.2-mm diameter duplex plastic optical fiber (POF)

### Applications

- Arc flash event detection
- Light detection

## Absolute Maximum Ratings

Stresses in excess of the absolute maximum ratings can cause catastrophic damage to the device. Limits apply to each parameter in isolation, all other parameters having values within the recommended operation conditions. It should not be assumed that limiting values of more than one parameter can be applied to the products at the same time. Exposure to the absolute maximum ratings for extended periods can adversely affect device reliability.

Parameter	Symbol	Min.	Max.	Unit	Notes
Storage Temperature	$T_S$	-40	+85	°C	a
Installation Temperature	$T_i$	0	+40	°C	a

- a. Storage and operating temperatures refer to the ranges over which the connectors can be used when not subjected to mechanical stress. Installation temperature refers to the ranges over which connectors may be installed onto the fiber and over which connectors can be connected and disconnected from the transceiver.

## Recommended Operating Conditions

Parameter	Symbol	Min.	Max.	Unit	Notes
Operating Temperature	$T_O$	-40	+85	°C	—

## Mechanical Characteristics

Parameter	Min.	Typ.	Max.	Unit	Note
Retention force, connector to point sensor	—	14	—	N	a
Insertion force, connector to point sensor	—	15	—	N	a
Tensile force, connector to cable	—	35	—	N	a
Screw tightening torque	—	0.7	—	Nm	b

- a. Typical data is at 25°C.  
 b. Values applicable when an M3 screw and an M3 washer are used.

## Optical Characteristics

Parameter	Symbol	Min.	Typ.	Max.	Unit	Notes
Capturing Constant	$C_p$	$1.1 \times 10^{-8}$	$1.8 \times 10^{-8}$	—	$m^2$	a, b
Insertion Loss	aT	—	13	20	dB	c

- a. Values measured with 10 m of POF duplex cable (1.0-mm core diameter, 2.2-mm jacket diameter, NA 0.5).  
 b.  $C_p$  definition: The capturing properties of a point sensor are characterized by  $C_p$ , called "Capturing Constant" of the point sensor, which is defined as follows:  
 The optical power  $P$  at the photo detector can be calculated as  $P = C_p \times E / K$   
 $P$ : Optical power on photo detector (W).  
 $C_p$ : Capturing constant ( $m^2$ )  
 $E$ : Optical power density in illuminated area ( $W / m^2$ ), halogen lamp used as a light source.  
 $K$ : Correction factor for transmission losses, calculated as:  $K = 10^{(A \times L2 / 10)}$ .  
 $A$ : Fiber transmission loss 0.34 dB/m.  
 $L2$ : Length of fiber between illuminated area and photo detector (m).  
 c. For heartbeat signal at 650 nm coupled from one fiber to the other fiber in a duplex cable.

# Acceptance Cone

Minimum 180° spherical.

Figure 1 Typical Acceptance Cone

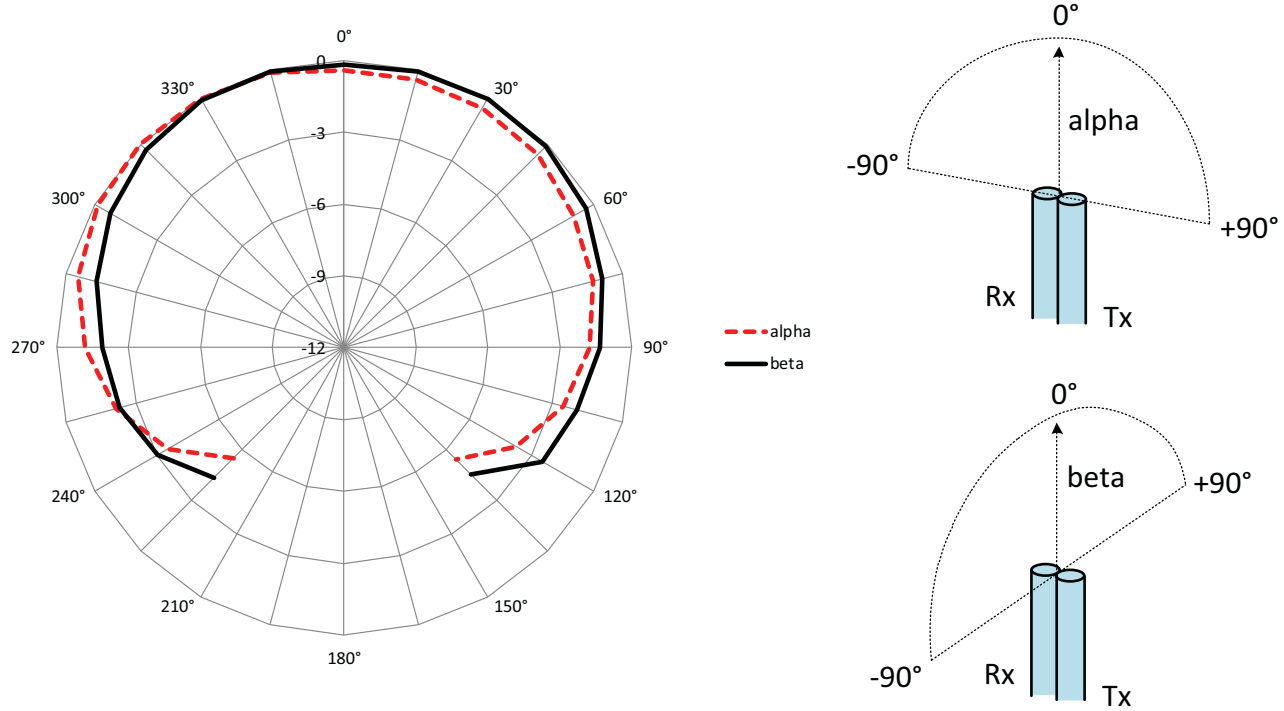

**NOTE** The values in the vertical axis are in dB.

# Mechanical Dimensions

Figure 2 AFBR-S10PS010Z

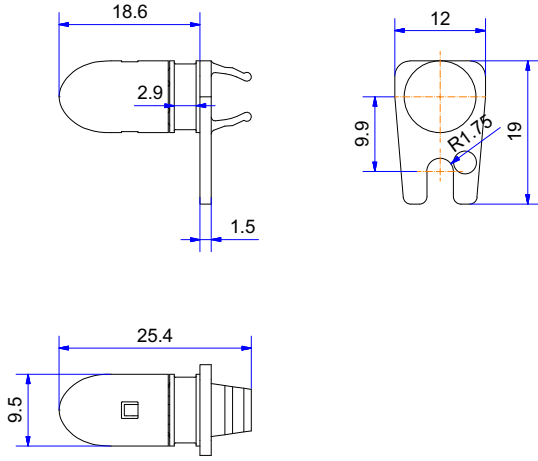

Figure 3 AFBR-S10PS11Z

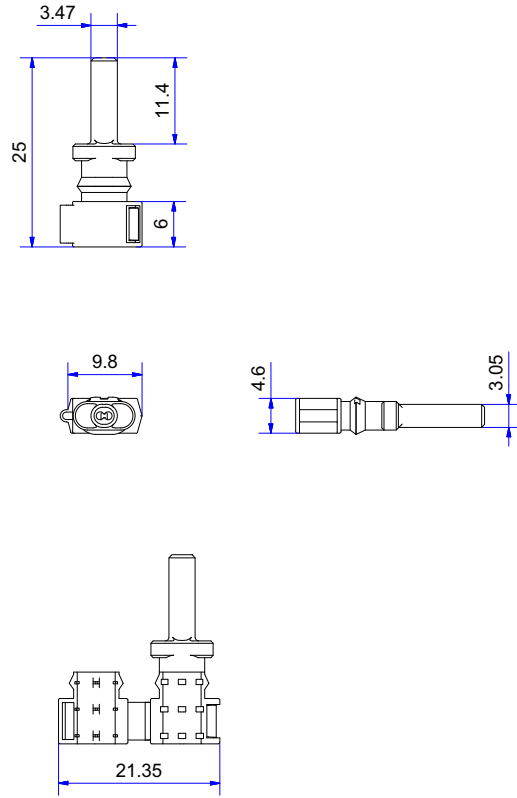
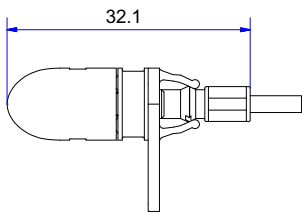

Figure 4 AFBR-S10PS010Z and AFBR-S10PSZ Assembled



**NOTE** All dimensions in mm.

---

For product information and a complete list of distributors, please go to our web site: [www.broadcom.com](http://www.broadcom.com).

Broadcom, the pulse logo, Connecting everything, Avago Technologies, Avago, and the A logo are among the trademarks of Broadcom and/or its affiliates in the United States, certain other countries and/or the EU.

Copyright © 2017 by Broadcom. All Rights Reserved.

The term "Broadcom" refers to Broadcom Limited and/or its subsidiaries. For more information, please visit [www.broadcom.com](http://www.broadcom.com).

Broadcom reserves the right to make changes without further notice to any products or data herein to improve reliability, function, or design.

Information furnished by Broadcom is believed to be accurate and reliable. However, Broadcom does not assume any liability arising out of the application or use of this information, nor the application or use of any product or circuit described herein, neither does it convey any license under its patent rights nor the rights of others.

AFBR-S10PS01XZ-DS100 – April 3, 2017

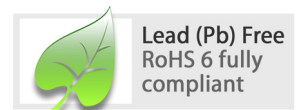

## Данный компонент на территории Российской Федерации

### Вы можете приобрести в компании MosChip.

Для оперативного оформления запроса Вам необходимо перейти по данной ссылке:

<http://moschip.ru/get-element>

Вы можете разместить у нас заказ для любого Вашего проекта, будь то серийное производство или разработка единичного прибора.

В нашем ассортименте представлены ведущие мировые производители активных и пассивных электронных компонентов.

Нашей специализацией является поставка электронной компонентной базы двойного назначения, продукции таких производителей как XILINX, Intel (ex.ALTERA), Vicor, Microchip, Texas Instruments, Analog Devices, Mini-Circuits, Amphenol, Glenair.

Сотрудничество с глобальными дистрибьюторами электронных компонентов, предоставляет возможность заказывать и получать с международных складов практически любой перечень компонентов в оптимальные для Вас сроки.

На всех этапах разработки и производства наши партнеры могут получить квалифицированную поддержку опытных инженеров.

Система менеджмента качества компании отвечает требованиям в соответствии с ГОСТ Р ИСО 9001, ГОСТ РВ 0015-002 и ЭС РД 009

### Офис по работе с юридическими лицами:

105318, г.Москва, ул.Щербаковская д.3, офис 1107, 1118, ДЦ «Щербаковский»

Телефон: +7 495 668-12-70 (многоканальный)

Факс: +7 495 668-12-70 (доб.304)

E-mail: [info@moschip.ru](mailto:info@moschip.ru)

Skype отдела продаж:

moschip.ru

moschip.ru\_4

moschip.ru\_6

moschip.ru\_9