

STR. MALE MODULE 4 COAX TYPE INSERTS

R694.251.025

3 MM FOR PCB

Series : MCC2

4 Coax Position AB/1B,1C

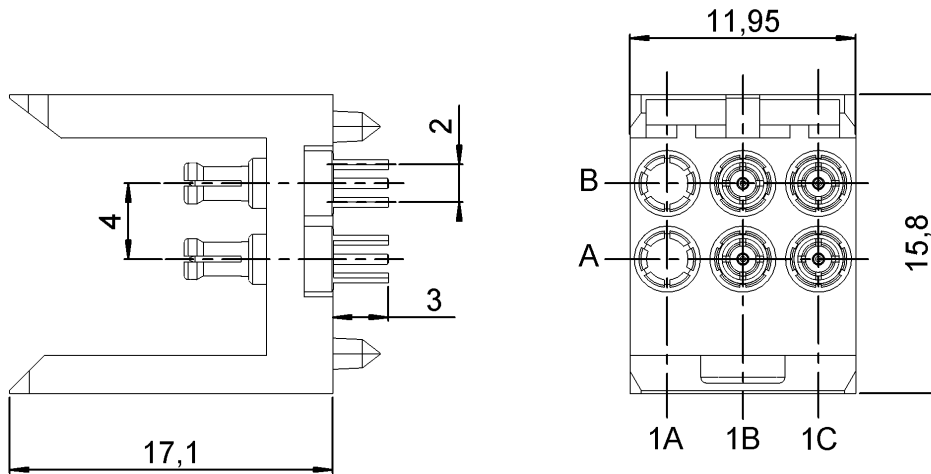

Connectors' packaging

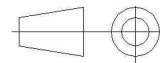
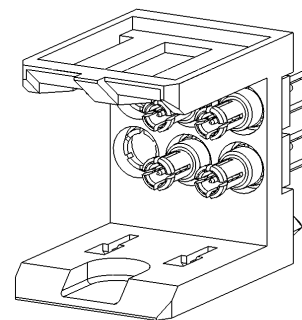
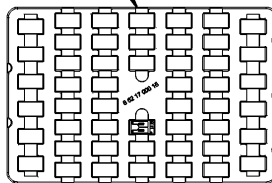
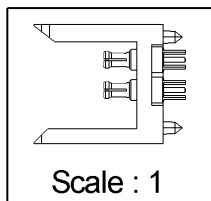

All dimensions are in mm.

COMPONENTS	MATERIALS	PLATING (µm)
BODY	BRONZE	NPGR
CENTER CONTACT	BRASS	NPGR
OUTER CONTACT	BRONZE	NPGR
INSULATOR	PTFE	
GASKET	-	
OTHERS PARTS	LIQUID CRISTAL POLYMER	
-	-	-
-	-	-

Issue : 0624 C

In the effort to improve our products, we reserve the right to make changes judged to be necessary.



STR. MALE MODULE 4 SOLDER TYPE INSERTS

R694.251.025

3 MM FOR PCB

Series : MCC2

PACKAGING

SPECIFICATION

Standard	Unit	Other
50	'W' option	Contact us

ELECTRICAL CHARACTERISTICS

ENVIRONMENTAL

Impedance	50	Ω
Frequency	0-6	GHz
VSWR	1.12 + 0,0000	x F(GHz) Maxi
Insertion loss	0.2	$\sqrt{F}(\text{GHz})$ dB Maxi
RF leakage	- (- F(GHz)) dB Maxi
Voltage rating	500	Veff Maxi
Dielectric withstanding voltage	750	Veff mini
Insulation resistance	5000	M Ω mini

Operating temperature	-25/+125	$^{\circ}\text{C}$
Hermetic seal	NA	Atm.cm3/s
Panel leakage	NA	

OTHER CHARACTERISTICS

Assembly instruction

Others :

VSWR=1.12 optimized between DC to 3GHz

MECHANICAL CHARACTERISTICS

Center contact retention		
Axial force – Mating end	6	N mini
Axial force – Opposite end	6	N mini
Torque	NA	N.cm mini
Recommended torque		
Mating	NA	N.cm
Panel nut	NA	N.cm
Mating life	500	Cycles mini
Weight	97,8400	g

Issue : 0624 C

In the effort to improve our products, we reserve the right to make changes judged to be necessary.



STR. MALE MODULE 4 SOLDER TYPE INSERTS

R694.251.025

3 MM FOR PCB

Series : MCC2

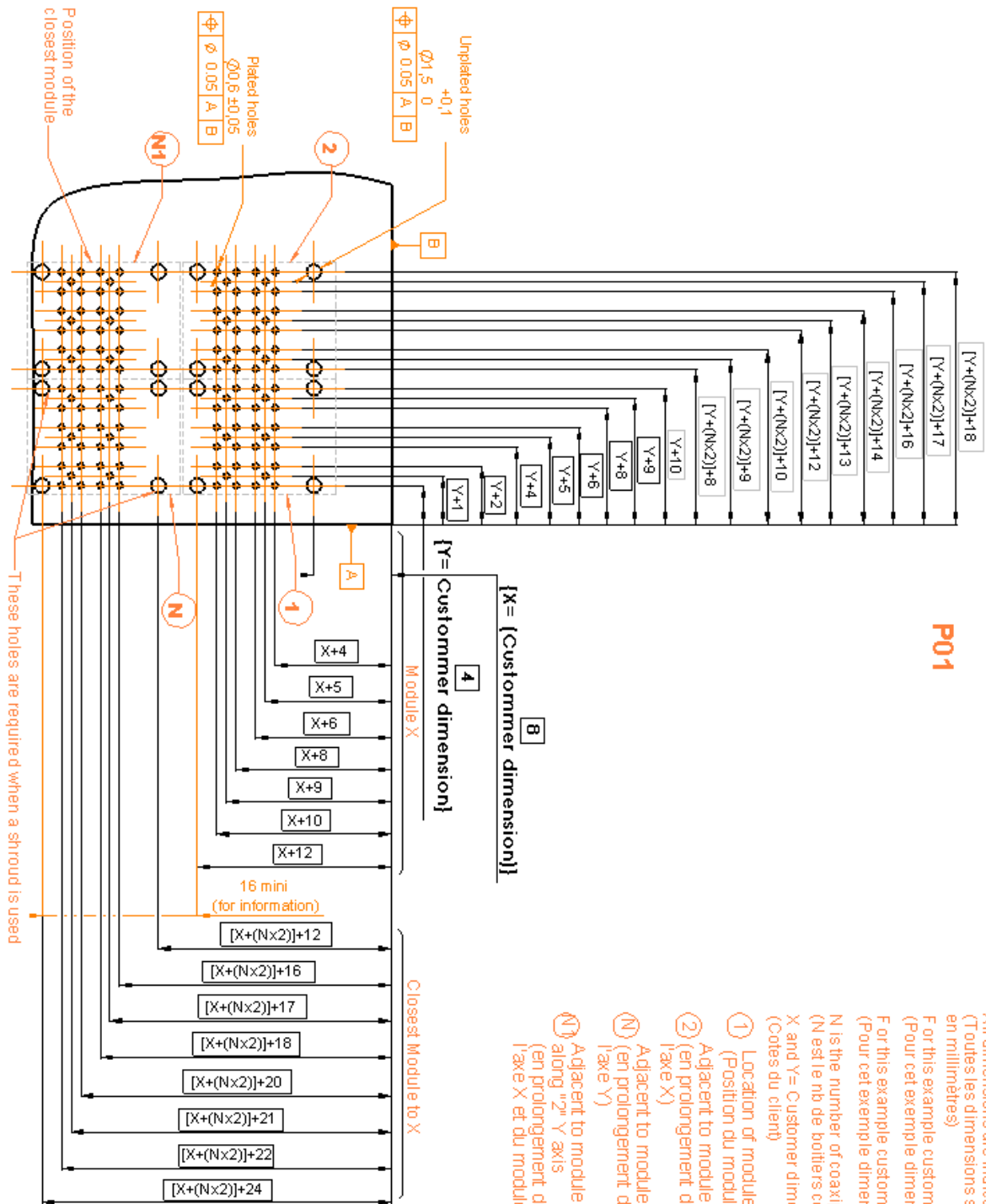

P01

- All dimensions are indicated in millimetres
(Toutes les dimensions sont indiquées en millimètres)
- F for this example customer dimension X=8mm
(Pour cet exemple dimension du client X=8mm)
- F or this example customer dimension Y=4mm
(Pour cet exemple dimension du client Y=4mm)
- N is the number of coaxipack 2
(N est le nb de boîtiers coaxipack 2)
- X and Y = Customer dimensions
(Codes du client)
- ① (Position of module "1")
Adjacent to module "1" along X axis
(en prolongement du module "1" selon l'axe X)
 - ② (en prolongement du module "1" selon l'axe X)
 - ③ Adjacent to module "N" along X axis and along "2" Y axis
(en prolongement du module "N" selon l'axe X et du module 2 selon l'axe Y)

Issue : 0624 C

In the effort to improve our products, we reserve the right to make changes judged to be necessary.



STR. MALE MODULE 4 SOLDER TYPE INSERTS

R694.251.025

3 MM FOR PCB

Series : MCC2

- Place the coax connector(s) on the PCB

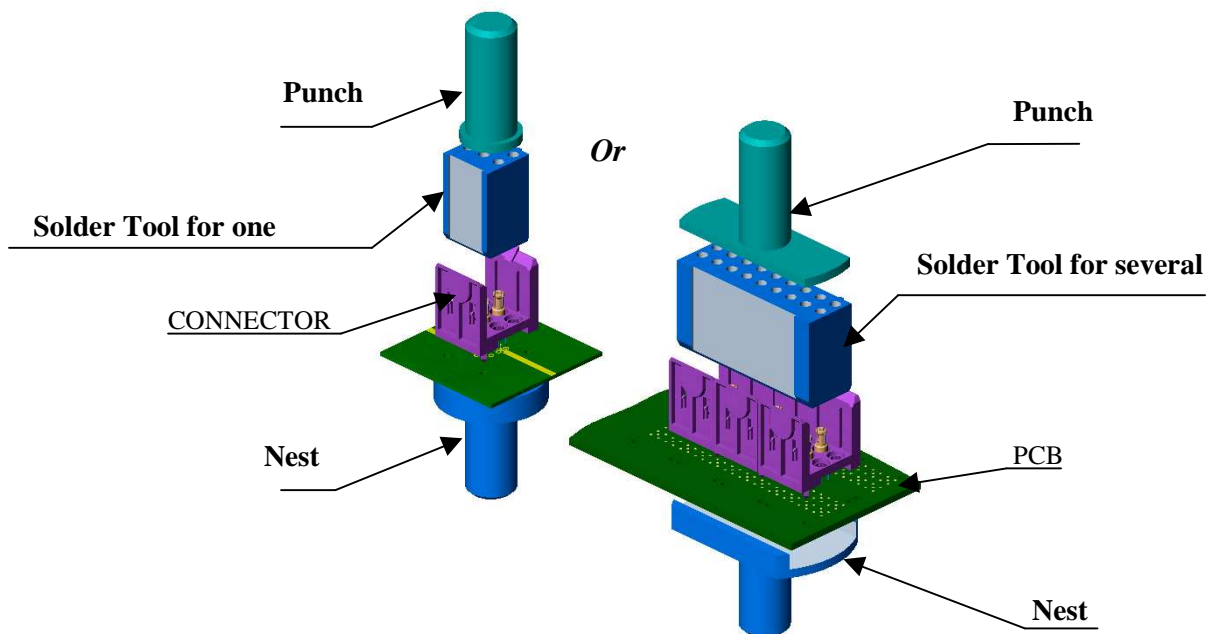

- Place correctly the PCB between the punch and the nest of the press.
- In case of multiple housing configuration , use a punch and a nest large enough to cover all the housings.
- Ensure solder legs are properly aligned with the holes before press-mounting.
- Press on the housing(s) with the punch until the complete insertion of the fixing stud into the PCB.

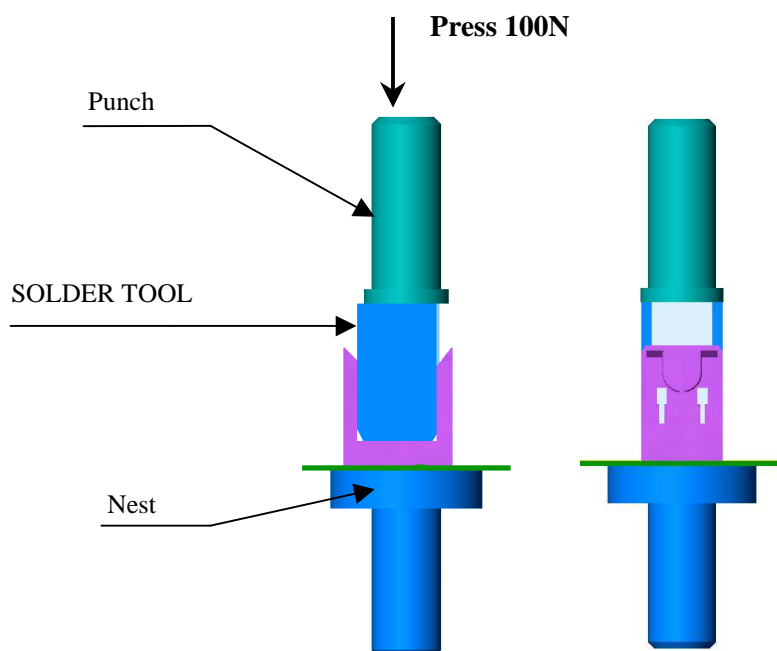

Issue : 0624 C

In the effort to improve our products, we reserve the right to make changes judged to be necessary.



STR. MALE MODULE 4 SOLDER TYPE INSERTS
3 MM FOR PCB

R694.251.025

Series : MCC2

- After the insertion of the connectors on the printed circuit , leave the solder tool inserted in position.
- Solder the legs on board

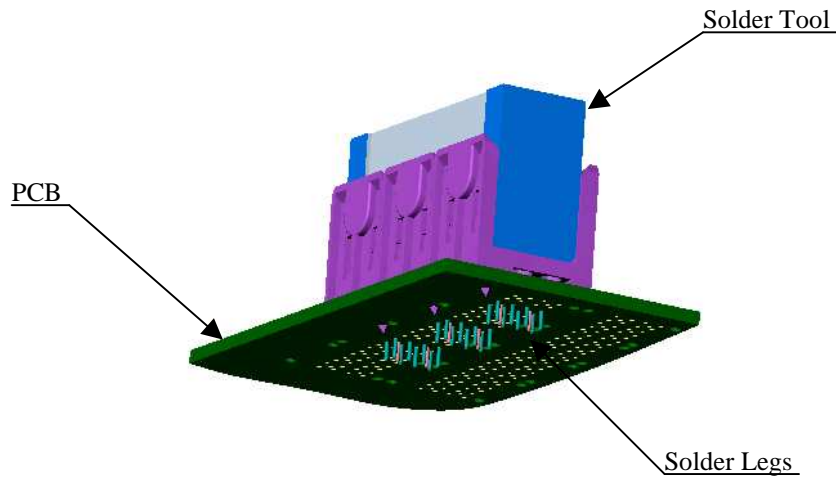

- After the solder legs have been soldered , using an appropriate soldering process , remove the solder tool.

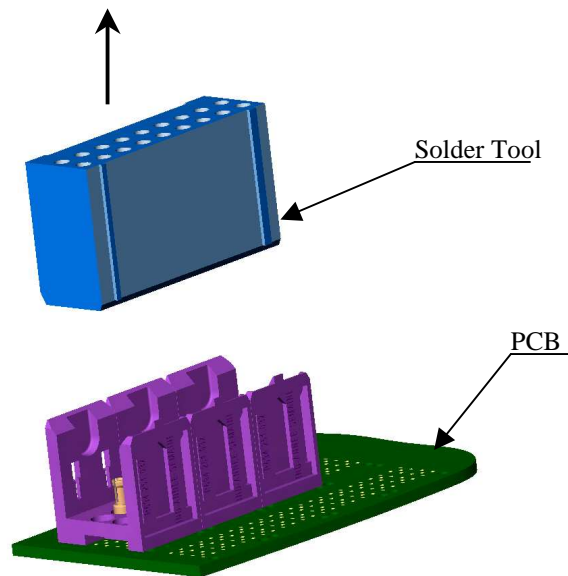

Radiall do not recommend to use more than 3 modules on the same motherboard and can't be held liable of any connection defect when more than 3 modules are implemented on the board.

Issue : 0624 C

In the effort to improve our products, we reserve the right to make changes judged to be necessary.



Данный компонент на территории Российской Федерации

Вы можете приобрести в компании MosChip.

Для оперативного оформления запроса Вам необходимо перейти по данной ссылке:

<http://moschip.ru/get-element>

Вы можете разместить у нас заказ для любого Вашего проекта, будь то серийное производство или разработка единичного прибора.

В нашем ассортименте представлены ведущие мировые производители активных и пассивных электронных компонентов.

Нашей специализацией является поставка электронной компонентной базы двойного назначения, продукции таких производителей как XILINX, Intel (ex.ALTERA), Vicor, Microchip, Texas Instruments, Analog Devices, Mini-Circuits, Amphenol, Glenair.

Сотрудничество с глобальными дистрибьюторами электронных компонентов, предоставляет возможность заказывать и получать с международных складов практически любой перечень компонентов в оптимальные для Вас сроки.

На всех этапах разработки и производства наши партнеры могут получить квалифицированную поддержку опытных инженеров.

Система менеджмента качества компании отвечает требованиям в соответствии с ГОСТ Р ИСО 9001, ГОСТ РВ 0015-002 и ЭС РД 009

Офис по работе с юридическими лицами:

105318, г.Москва, ул.Щербаковская д.3, офис 1107, 1118, ДЦ «Щербаковский»

Телефон: +7 495 668-12-70 (многоканальный)

Факс: +7 495 668-12-70 (доб.304)

E-mail: info@moschip.ru

Skype отдела продаж:

moschip.ru

moschip.ru_4

moschip.ru_6

moschip.ru_9