

## IO-Link industrial modular sensor board based on L6362A

Data brief

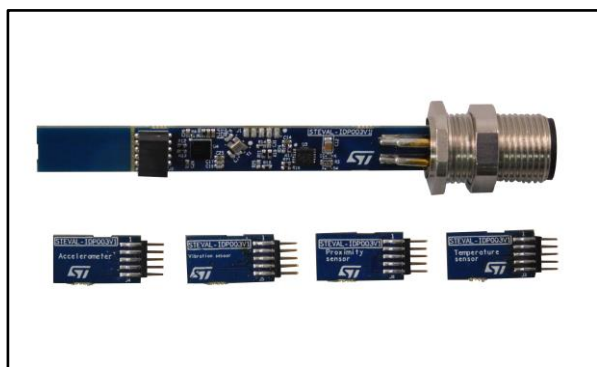

### Description

The STEVAL-IDP003V1 kit includes the STEVAL-IDP003V1D evaluation board based on the L6362A IO-Link device transceiver and STM32L071CZ microcontroller for data processing, and the following sensor daughter boards: temperature sensor STTS751 hosted on the STEVAL-IDP003V1T, MEMS sensor IIS2DH hosted on the STEVAL-IDP003V1TV, MEMS sensor IIS328DQ hosted on the STEVAL-IDP003V1A and proximity sensor VL6180X hosted on the STEVAL-IDP003V1P.

The evaluation board is equipped with an industrial M12 connector (required by the standard) for connection with a single master IC using a 20-meter cable. The wire is a normal three-pole wire: one for IO-Link data, one for the L+ line (positive supply voltage pole) and one for the L- line (negative supply voltage pole).

The layout is designed to meet IEC61000-4-2/4 and EN60947 requirements for the industrial sector.

### Features

- Main supply voltage: 32 V maximum
- STM32L071CZ microcontroller
- IO-Link PHY using the L6362A device for data communication with host unit
- DC-DC converter and linear regulator on board
- Integrated reverse polarity protection on L6362A ICs
- Multi-sensor connection
- 400 kHz I<sup>2</sup>C communication
- PCB designed to accept real industrial sensors (8 mm x 70 mm, with 0.8 mm thickness)
- Designed to meet IEC industrial standard requirements
- RoHS compliant

# 1 Block identification

In the kit, the main board is the STEVAL-IDP003V1.

Figure 1: STEVAL-IDP003V1 block identification

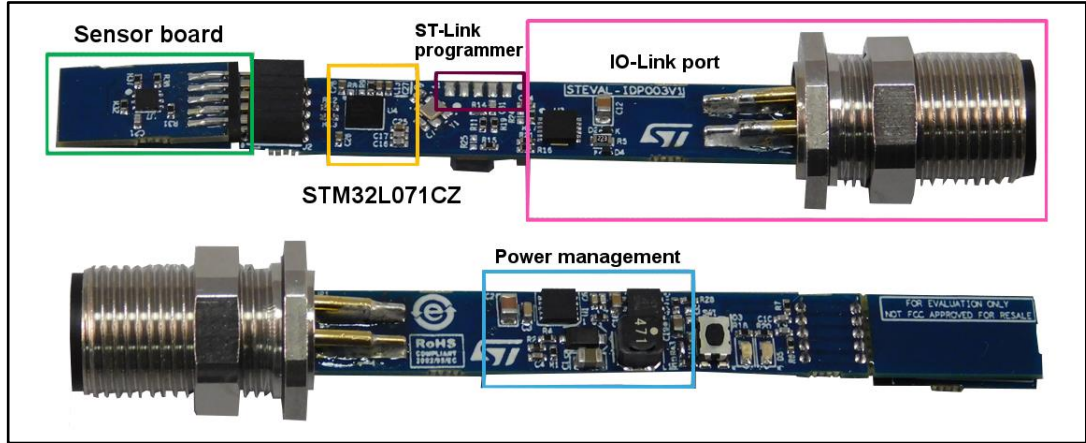

The picture below shows the sensor daughter boards, from the top left corner in a clockwise direction: STEVAL-IDP003V1T, STEVAL-IDP003V1P, STEVAL-IDP003V1A and STEVAL-IDP003V1TV. The corresponding sensor part numbers are also shown.

Figure 2: Sensor boards

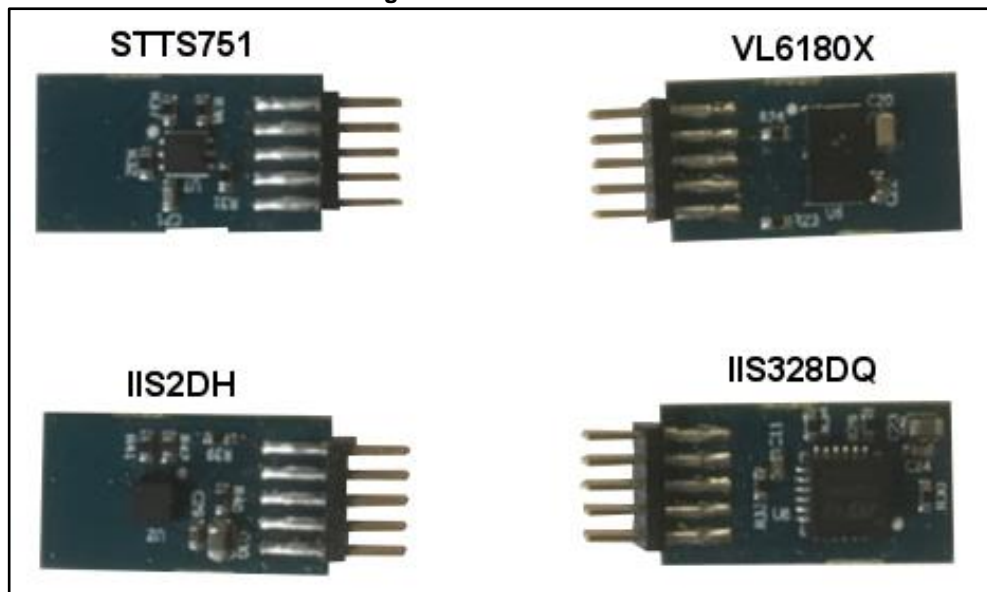

## 2 Schematic diagrams

Figure 3: STEVAL-IDP003V1 circuit schematic (1 of 6)

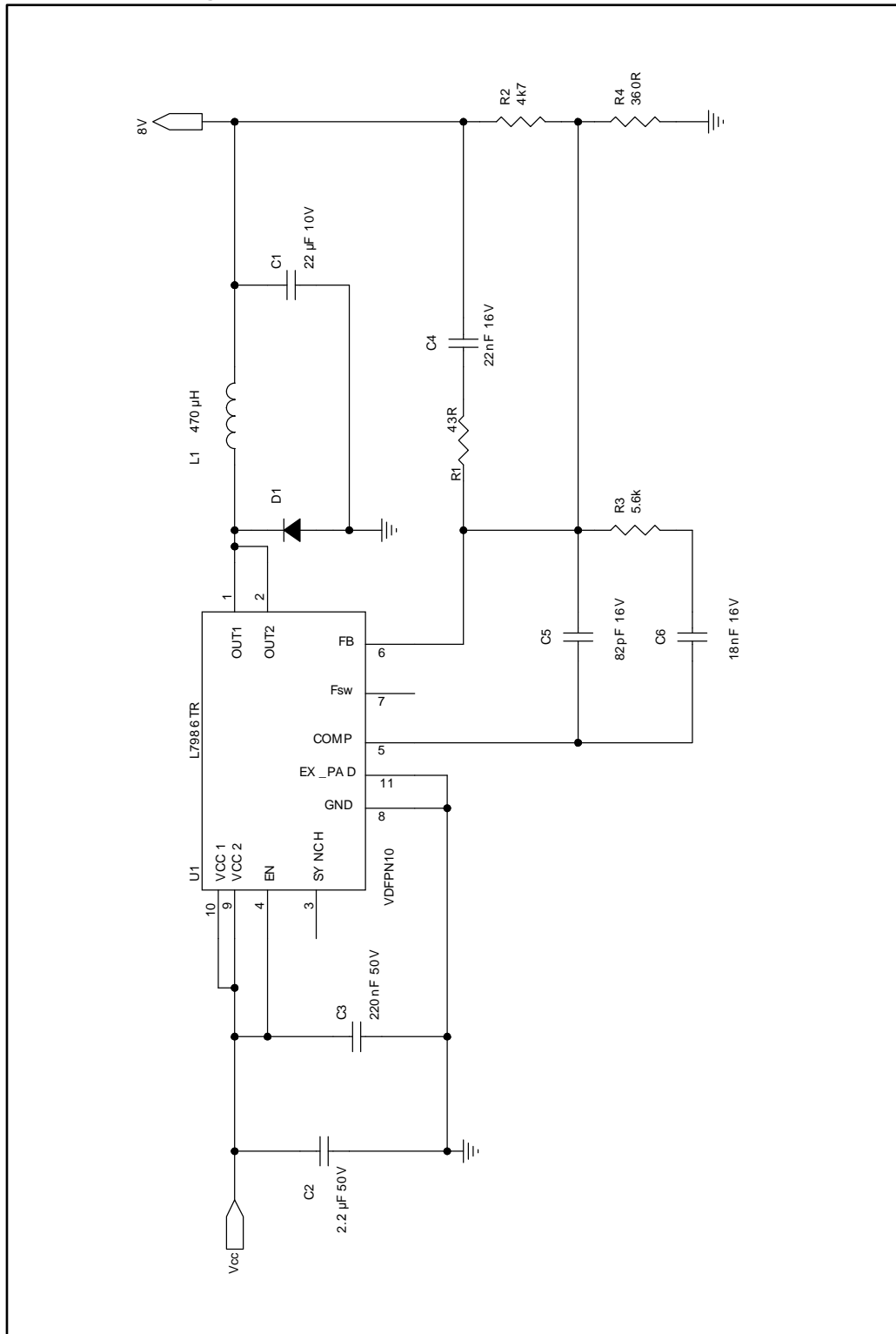

Figure 4: STEVAL-IDP003V1 circuit schematic (2 of 6)

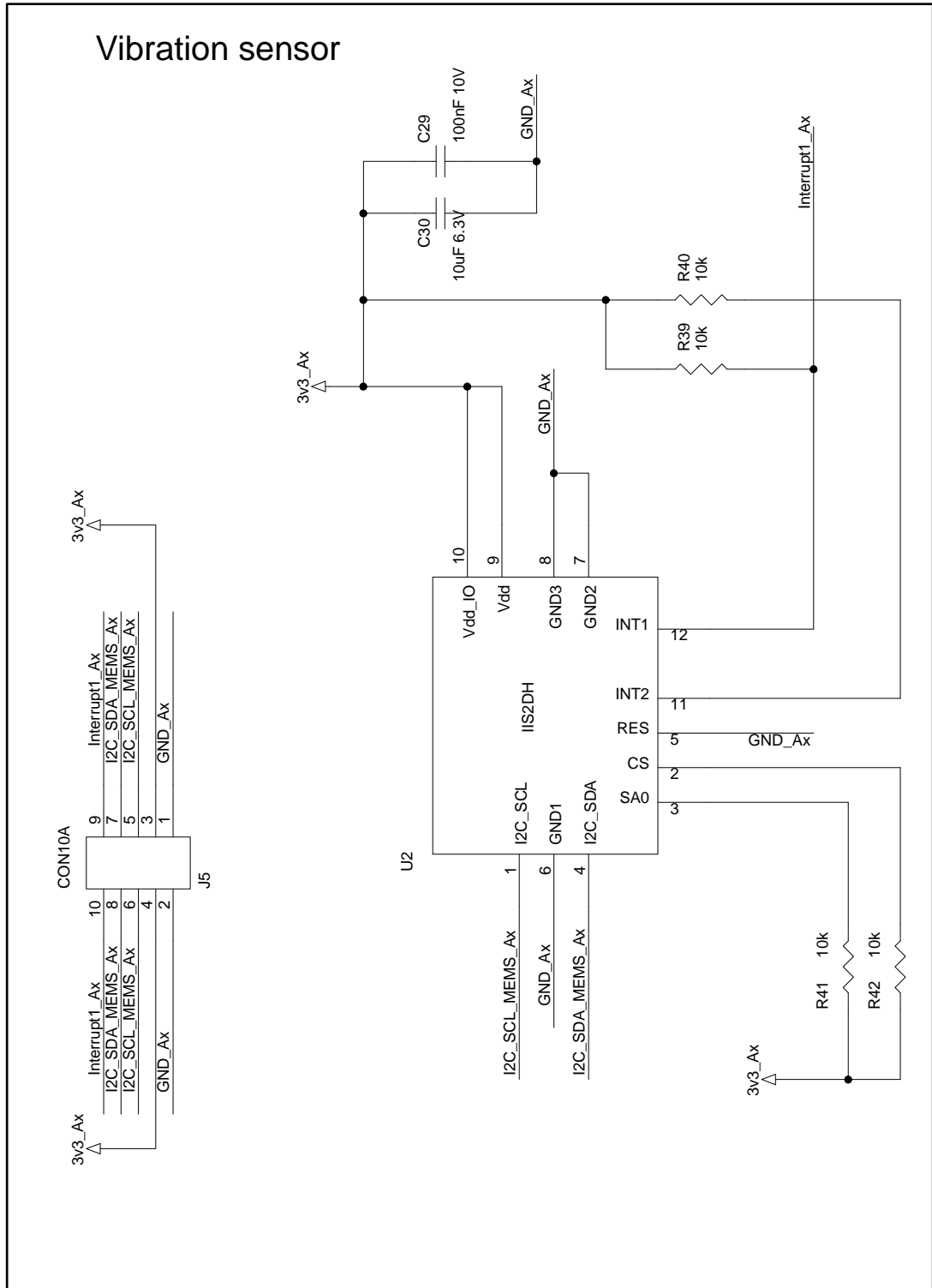

Figure 5: STEVAL-IDP003V1 circuit schematic (3 of 6)

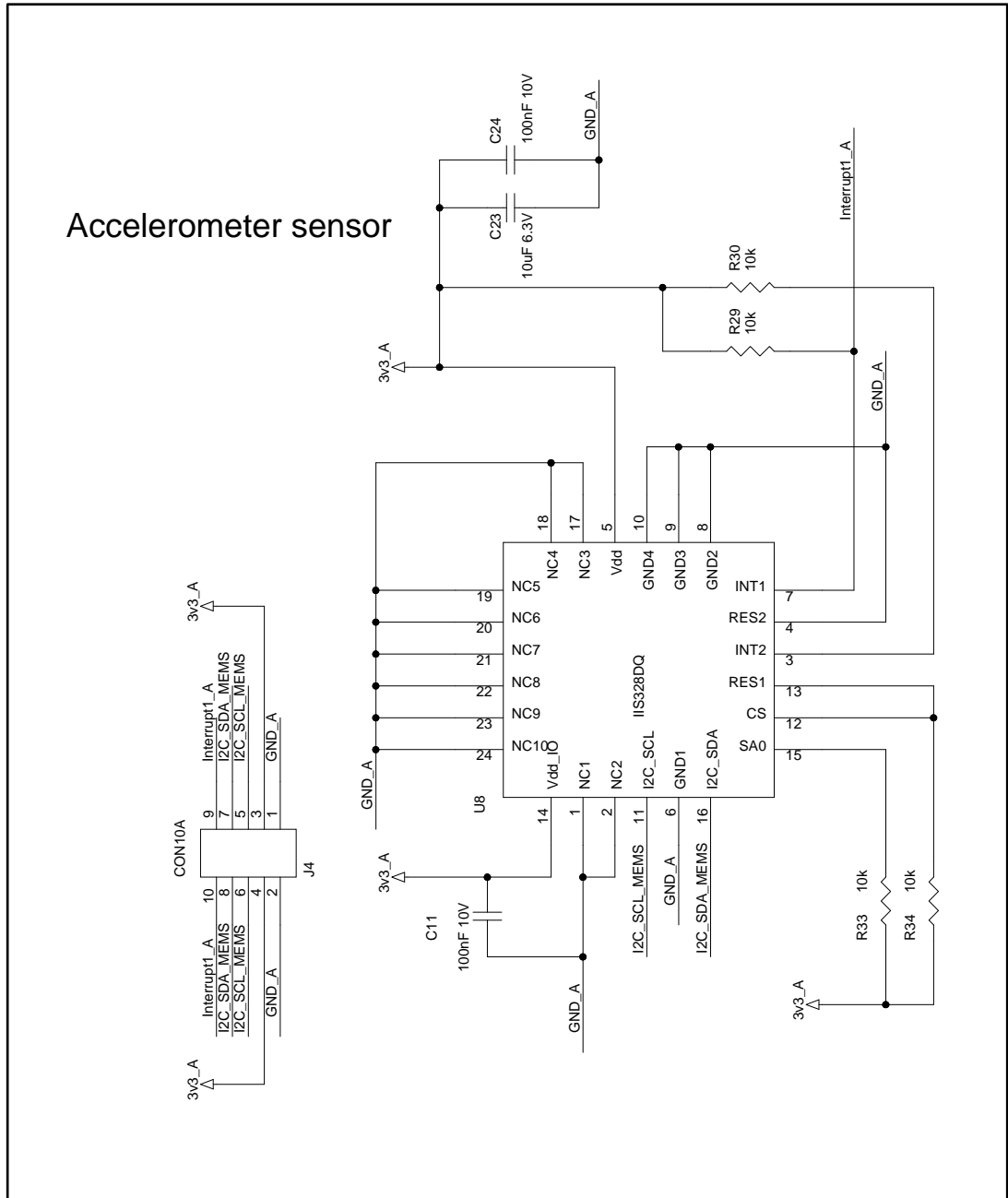

Figure 6: STEVAL-IDP003V1 circuit schematic (4 of 6)

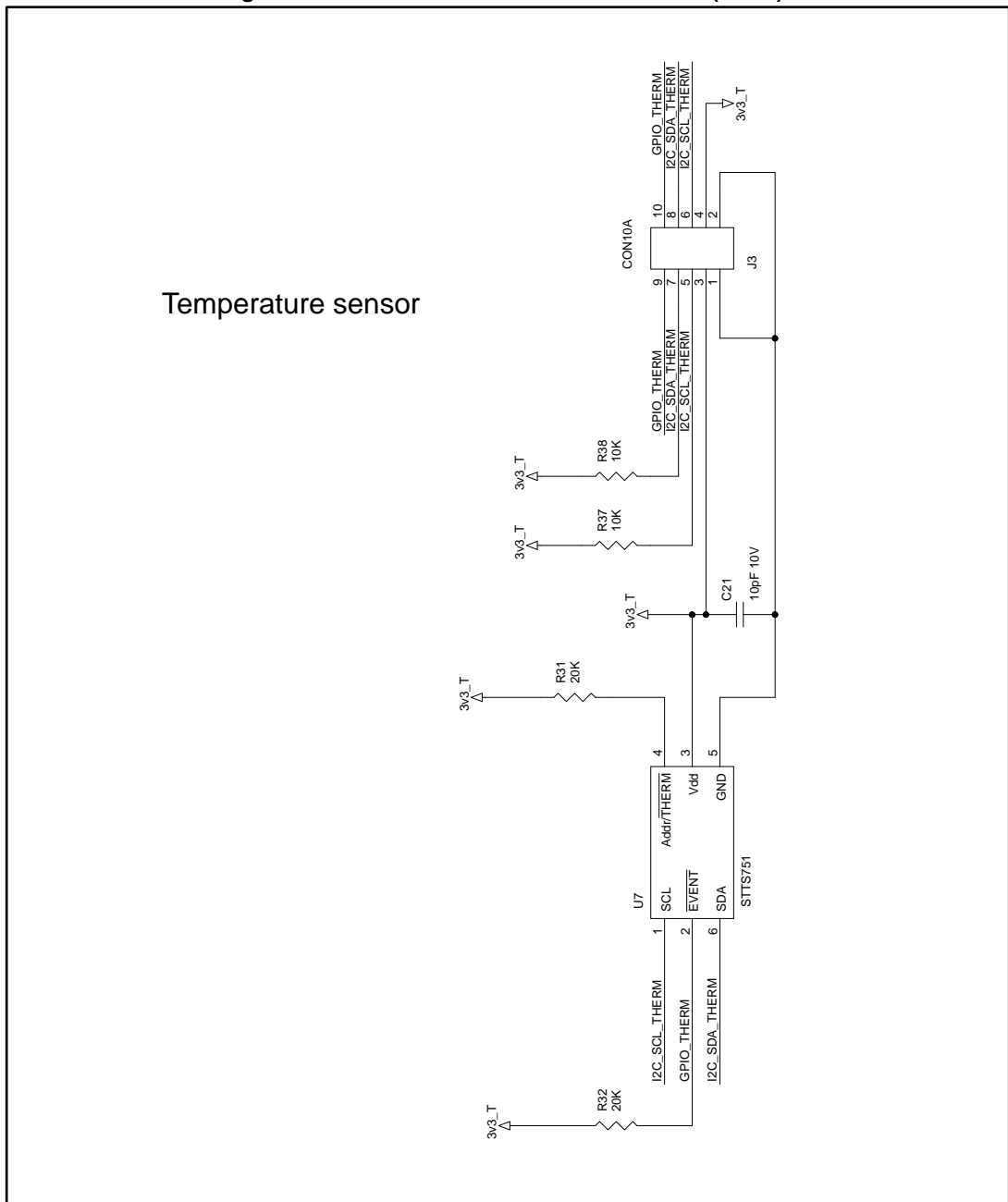

Figure 7: STEVAL-IDP003V1 circuit schematic (5 of 6)

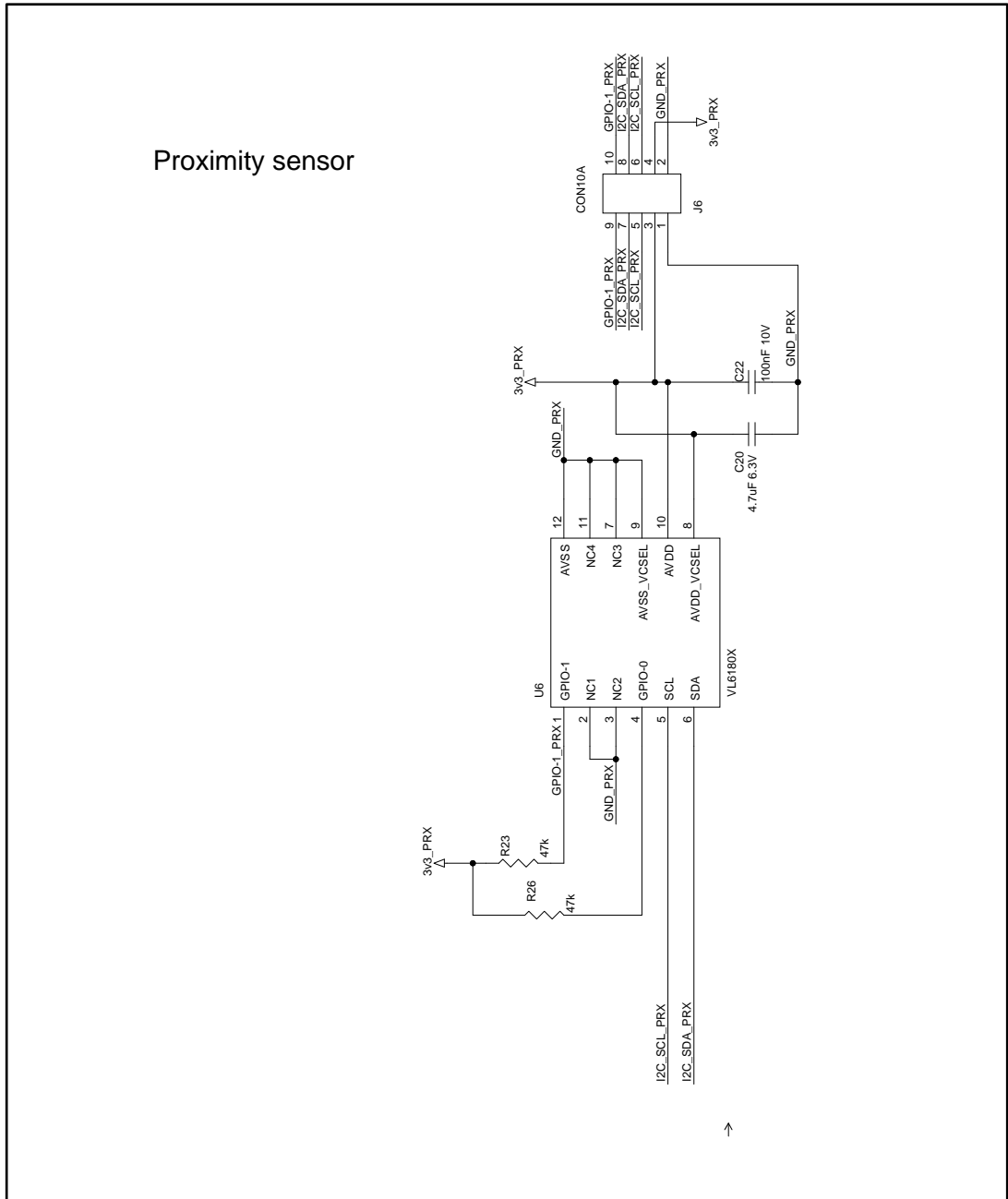
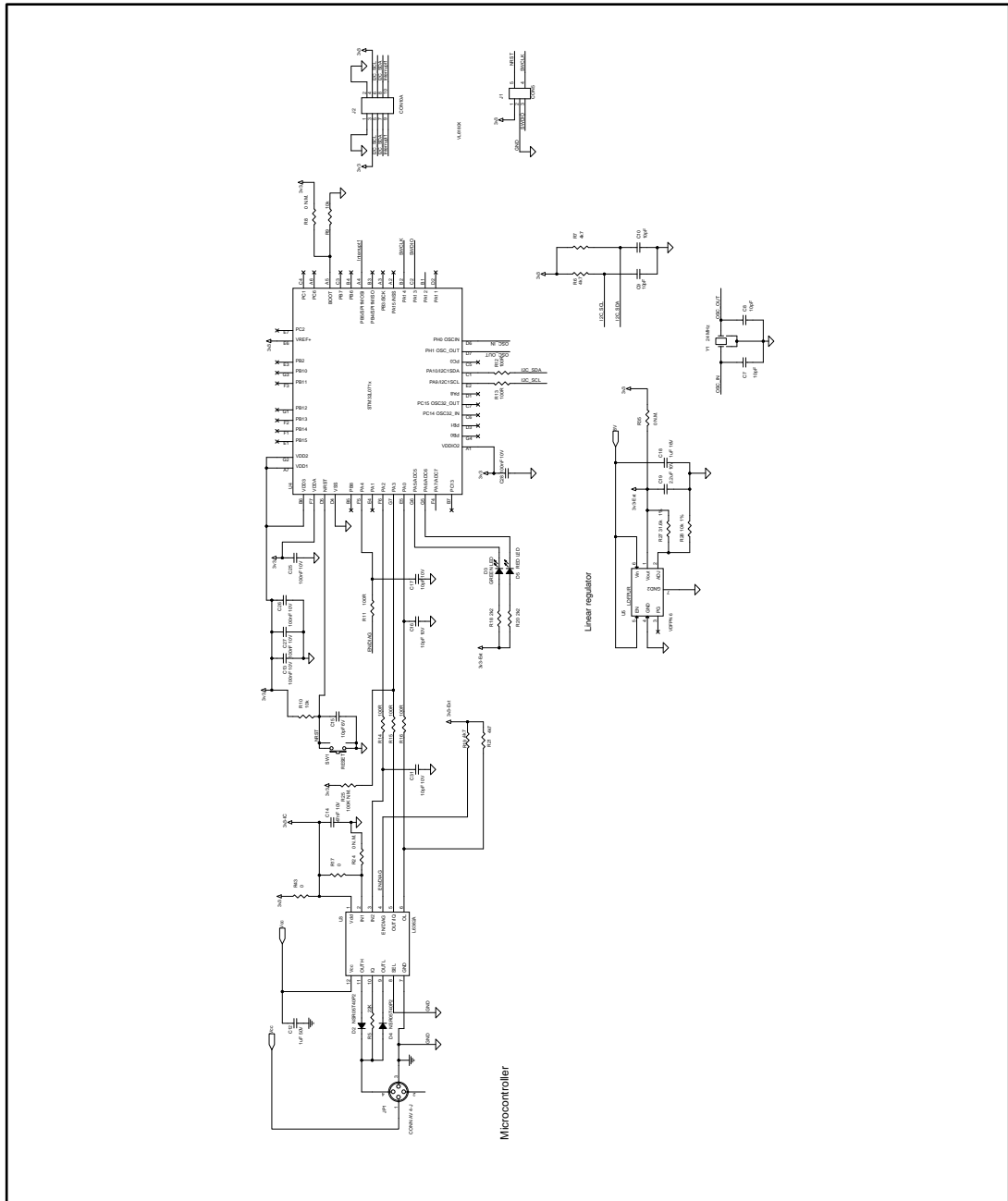

Figure 8: STEVAL-IDP003V1 circuit schematic (6 of 6)





### 3 Revision history

Table 1: Document revision history

Date	Version	Changes
09-Jun-2017	1	Initial release.
25-Oct-2017	2	Updated <a href="#">Figure 3: "STEVAL-IDP003V1 circuit schematic (1 of 6)"</a> . Minor text changes.

**IMPORTANT NOTICE – PLEASE READ CAREFULLY**

STMicroelectronics NV and its subsidiaries ("ST") reserve the right to make changes, corrections, enhancements, modifications, and improvements to ST products and/or to this document at any time without notice. Purchasers should obtain the latest relevant information on ST products before placing orders. ST products are sold pursuant to ST's terms and conditions of sale in place at the time of order acknowledgement.

Purchasers are solely responsible for the choice, selection, and use of ST products and ST assumes no liability for application assistance or the design of Purchasers' products.

No license, express or implied, to any intellectual property right is granted by ST herein.

Resale of ST products with provisions different from the information set forth herein shall void any warranty granted by ST for such product.

ST and the ST logo are trademarks of ST. All other product or service names are the property of their respective owners.

Information in this document supersedes and replaces information previously supplied in any prior versions of this document.

© 2017 STMicroelectronics – All rights reserved

## Данный компонент на территории Российской Федерации

### Вы можете приобрести в компании MosChip.

Для оперативного оформления запроса Вам необходимо перейти по данной ссылке:

<http://moschip.ru/get-element>

Вы можете разместить у нас заказ для любого Вашего проекта, будь то серийное производство или разработка единичного прибора.

В нашем ассортименте представлены ведущие мировые производители активных и пассивных электронных компонентов.

Нашей специализацией является поставка электронной компонентной базы двойного назначения, продукции таких производителей как XILINX, Intel (ex.ALTERA), Vicor, Microchip, Texas Instruments, Analog Devices, Mini-Circuits, Amphenol, Glenair.

Сотрудничество с глобальными дистрибьюторами электронных компонентов, предоставляет возможность заказывать и получать с международных складов практически любой перечень компонентов в оптимальные для Вас сроки.

На всех этапах разработки и производства наши партнеры могут получить квалифицированную поддержку опытных инженеров.

Система менеджмента качества компании отвечает требованиям в соответствии с ГОСТ Р ИСО 9001, ГОСТ РВ 0015-002 и ЭС РД 009

### Офис по работе с юридическими лицами:

105318, г.Москва, ул.Щербаковская д.3, офис 1107, 1118, ДЦ «Щербаковский»

Телефон: +7 495 668-12-70 (многоканальный)

Факс: +7 495 668-12-70 (доб.304)

E-mail: [info@moschip.ru](mailto:info@moschip.ru)

Skype отдела продаж:

moschip.ru

moschip.ru\_4

moschip.ru\_6

moschip.ru\_9