

Automotive 8-bit MCU, with up to 8-Kbyte Flash memory, data EEPROM, 10-bit ADC, timers, LIN, SPI, I²C, 3 to 5.5 V

Datasheet - production data

Features



- AEC-Q100 qualified
- Core
 - Max f_{CPU} : 16 MHz
 - Advanced STM8A core with Harvard architecture and 3-stage pipeline
 - Extended instruction set
- Memories
 - Program memory: 4 to 8 Kbyte Flash program; data retention 20 years at 55 °C after 1 kcycle
 - Data memory: 640 byte true data EEPROM; endurance 300 kcycle
 - RAM: 1 Kbyte
- Clock management
 - Low-power crystal resonator oscillator with external clock input
 - Internal, user-trimmable 16 MHz RC and low-power 128 kHz RC oscillators
 - Clock security system with clock monitor
- Reset and supply management
 - Wait/auto-wakeup/Halt low-power modes with user definable clock gating
 - Low-consumption power-on and power-down reset
- Interrupt management
 - Nested interrupt controller with 32 interrupts
 - Up to 28 external interrupts on 7 vectors
- Timers
 - Advanced control timer: 16-bit, 4 CAPCOM channels, 3 complementary outputs, dead-time insertion and flexible synchronization
 - 16-bit general purpose timer with 3 CAPCOM channels each (IC, OC, PWM)
 - 8-bit AR basic timer with 8-bit prescaler
 - Auto-wakeup timer
 - Window and independent watchdog timers

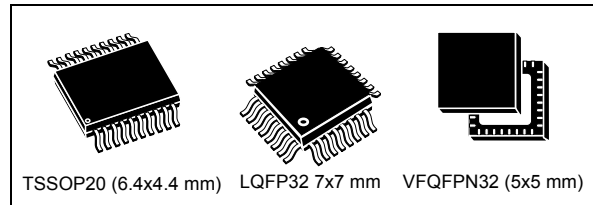

- I/Os
 - Up to 28 I/Os on a 32-pin package including 21 high sink outputs
 - Highly robust I/O design, immune against current injection
- Communication interfaces
 - LINUART LIN 2.2 compliant, master/slave modes with automatic resynchronization
 - SPI interface up to 8 Mbit/s or $f_{MASTER}/2$
 - I²C interface up to 400 Kbit/s
- Analog to digital converter (ADC)
 - 10-bit, ± 1 LSB ADC with up to 7 muxed channels + 1 internal channel, scan mode and analog watchdog
 - Internal reference voltage measurement
- Operating temperature up to 150 °C

Contents

1	Introduction	9
2	Description	10
3	Block diagram	11
4	Product overview	12
4.1	Central processing unit (CPU)	12
4.1.1	Architecture and registers	12
4.1.2	Addressing	12
4.1.3	Instruction set	12
4.2	Single wire interface module (SWIM) and debug module (DM)	13
4.2.1	SWIM	13
4.2.2	Debug module	13
4.3	Interrupt controller	13
4.4	Flash program and data EEPROM memory	13
4.4.1	Write protection (WP)	13
4.4.2	Read-out protection (ROP)	14
4.5	Clock controller	15
4.5.1	Features	15
4.6	Power management	16
4.7	Watchdog timers	16
4.8	Auto wakeup counter	17
4.9	Beeper	17
4.10	TIM1 - 16-bit advanced control timer	17
4.11	TIM5 - 16-bit general purpose timer	18
4.12	TIM6 - 8-bit basic timer	18
4.13	Analog-to-digital converter (ADC1)	19
4.14	Communication interfaces	19
4.14.1	LINUART	20
4.14.2	Serial peripheral interface (SPI)	21
4.14.3	Inter integrated circuit (I ² C) interface	21

5	Pinout and pin description	22
5.1	TSSOP20 pinouts and pin descriptions	22
5.2	LQFP32/VFQPN32 pinout and pin description	28
5.3	Alternate function remapping	32
6	Memory and register map	33
6.1	Memory map	33
6.2	Register map	34
6.2.1	I/O port hardware register map	34
6.2.2	CPU/SWIM/debug module/interrupt controller registers	42
7	Interrupt vector mapping	44
8	Option bytes	46
8.1	Option byte description	47
8.2	STM8AF6213/13A/23/23A/26 alternate function remapping bits	48
9	Unique ID	52
10	Electrical characteristics	53
10.1	Parameter conditions	53
10.1.1	Minimum and maximum values	53
10.1.2	Typical values	53
10.1.3	Typical curves	53
10.1.4	Loading capacitor	53
10.1.5	Pin input voltage	54
10.2	Absolute maximum ratings	54
10.3	Operating conditions	56
10.3.1	VCAP external capacitor	58
10.3.2	Supply current characteristics	58
10.3.3	External clock sources and timing characteristics	67
10.3.4	Internal clock sources and timing characteristics	69
10.3.5	Memory characteristics	70
10.3.6	I/O port pin characteristics	72
10.3.7	Reset pin characteristics	79
10.3.8	SPI serial peripheral interface	81

	10.3.9	I ² C interface characteristics	84
	10.3.10	10-bit ADC characteristics	86
	10.3.11	EMC characteristics	89
11		Package information	92
	11.1	TSSOP20 package information	92
	11.2	LQFP32 package information	96
	11.3	VFQFPN32 package information	99
	11.4	Thermal characteristics	103
	11.4.1	Reference document	103
	11.4.2	Selecting the product temperature range	103
12		Ordering information	105
13		STM8 development tools	106
	13.1	Emulation and in-circuit debugging tools	106
	13.1.1	STice key features	106
	13.2	Software tools	107
	13.2.1	STM8 toolset	107
	13.2.2	C and assembly toolchains	107
	13.3	Programming tools	108
14		Revision history	109

List of tables

Table 1.	STM8AF6213/13A/23/23A/26 features	10
Table 2.	Peripheral clock gating bit assignments in CLK_PCKENR1/2 registers	15
Table 3.	TIM timer features	18
Table 4.	Communication peripheral naming correspondence	19
Table 5.	Legend/abbreviations for pinout tables	22
Table 6.	STM8AF6213/STM8AF6223 TSSOP20 pin description	23
Table 7.	STM8AF6213A and STM8AF6223A TSSOP20 pin description	25
Table 8.	STM8AF6226 LQFP32/VFQPN32 pin description	28
Table 9.	Memory model for the devices covered in this datasheet	34
Table 10.	I/O port hardware register map	34
Table 11.	General hardware register map	35
Table 12.	CPU/SWIM/debug module/interrupt controller registers	42
Table 13.	Interrupt mapping	44
Table 14.	Option bytes	46
Table 15.	Option byte description	47
Table 16.	STM8AF6226 alternate function remapping bits [7:2] for 32-pin packages	48
Table 17.	STM8AF6213 and STM8AF6223 alternate function remapping bits [7:2] for 20-pin packages	49
Table 18.	STM8AF6213A and STM8AF6223A alternate function remapping bits [7:2] for 20-pin packages	49
Table 19.	STM8AF6226 alternate function remapping bits [1:0] for 32-pin packages	50
Table 20.	STM8AF6213/STM8AF6223 alternate function remapping bits [1:0] for 20-pin packages	50
Table 21.	STM8AF6223A alternate function remapping bits [1:0] for 20-pin packages	51
Table 22.	Unique ID bit description	52
Table 23.	Voltage characteristics	54
Table 24.	Current characteristics	55
Table 25.	Thermal characteristics	55
Table 26.	Operating lifetime (OLF)	55
Table 27.	General operating conditions	56
Table 28.	Operating conditions at power-up/power-down	57
Table 29.	Total current consumption with code execution in run mode at $V_{DD} = 5\text{ V}$	58
Table 30.	Total current consumption with code execution in run mode at $V_{DD} = 3.3\text{ V}$	59
Table 31.	Total current consumption in wait mode at $V_{DD} = 5\text{ V}$	60
Table 32.	Total current consumption in wait mode at $V_{DD} = 3.3\text{ V}$	60
Table 33.	Total current consumption in active halt mode at $V_{DD} = 5\text{ V}$	61
Table 34.	Total current consumption in active halt mode at $V_{DD} = 3.3\text{ V}$	61
Table 35.	Total current consumption in halt mode at $V_{DD} = 5\text{ V}$	62
Table 36.	Total current consumption in halt mode at $V_{DD} = 3.3\text{ V}$	62
Table 37.	Wakeup times	62
Table 38.	Total current consumption and timing in forced reset state	63
Table 39.	Peripheral current consumption	63
Table 40.	HSE user external clock characteristics	67
Table 41.	HSE oscillator characteristics	68
Table 42.	HSI oscillator characteristics	69
Table 43.	LSI oscillator characteristics	70
Table 44.	RAM and hardware registers	70
Table 45.	Flash program memory/data EEPROM memory	70

Table 46.	Flash program memory	71
Table 47.	Data memory	71
Table 48.	I/O static characteristics	72
Table 49.	Output driving current (standard ports)	74
Table 50.	Output driving current (true open drain ports)	74
Table 51.	Output driving current (high sink ports)	75
Table 52.	NRST pin characteristics	79
Table 53.	SPI characteristics	81
Table 54.	I ² C characteristics	84
Table 55.	ADC characteristics	86
Table 56.	ADC accuracy with RAIN < 10 k Ω , V _{DD} = 5 V	87
Table 57.	ADC accuracy with RAIN < 10 k Ω , V _{DD} = 3.3 V	87
Table 58.	EMS data	89
Table 59.	EMI data	90
Table 60.	ESD absolute maximum ratings	90
Table 61.	Electrical sensitivities	91
Table 62.	TSSOP20 – 20-lead thin shrink small outline, 6.5 x 4.4 mm, 0.65 mm pitch, package mechanical data	93
Table 63.	LQFP32 - 32-pin, 7 x 7 mm low-profile quad flat package mechanical data	97
Table 64.	VFQFPN32 - 32-pin, 5x5 mm, 0.5 mm pitch very thin profile fine pitch quad flat package mechanical data	100
Table 65.	Thermal characteristics	103
Table 66.	STM8AF6213/13A/23/23A/26 ordering information scheme	105
Table 67.	Document revision history	109

List of figures

Figure 1.	STM8AF6213/13A/23/23A/26 block diagram	11
Figure 2.	Flash memory organization	14
Figure 3.	STM8AF6213/STM8AF6223 TSSOP20 pinout	22
Figure 4.	STM8AF6213A and STM8AF6223A TSSOP20 pinout	23
Figure 5.	STM8AF6226 LQFP32/VFQPN32 pinout	28
Figure 6.	Memory map	33
Figure 7.	Pin loading conditions	53
Figure 8.	Pin input voltage	54
Figure 9.	f_{CPUmax} versus V_{DD}	57
Figure 10.	External capacitor C_{EXT}	58
Figure 11.	Typ $I_{DD(RUN)}$ vs. V_{DD} HSE user external clock, $f_{CPU} = 16$ MHz	64
Figure 12.	Typ $I_{DD(RUN)}$ vs. f_{CPU} HSE user external clock, $V_{DD} = 5$ V	64
Figure 13.	Typ $I_{DD(RUN)}$ vs. V_{DD} HSEI RC osc., $f_{CPU} = 16$ MHz	65
Figure 14.	Typ $I_{DD(WFI)}$ vs. V_{DD} HSE user external clock, $f_{CPU} = 16$ MHz	65
Figure 15.	Typ $I_{DD(WFI)}$ vs. f_{CPU} HSE user external clock, $V_{DD} = 5$ V	66
Figure 16.	Typ $I_{DD(WFI)}$ vs. V_{DD} HSI RC osc., $f_{CPU} = 16$ MHz	66
Figure 17.	HSE external clock source	67
Figure 18.	HSE oscillator circuit diagram	68
Figure 19.	Typical V_{IL} and V_{IH} vs V_{DD} @ 4 temperatures	73
Figure 20.	Typical pull-up resistance R_{PU} vs V_{DD} @ 4 temperatures	73
Figure 21.	Typical pull-up current I_{pu} vs V_{DD} @ 4 temperatures	74
Figure 22.	Typ. V_{OL} @ $V_{DD} = 5$ V (standard ports)	75
Figure 23.	Typ. V_{OL} @ $V_{DD} = 3.3$ V (standard ports)	75
Figure 24.	Typ. V_{OL} @ $V_{DD} = 5$ V (true open drain ports)	76
Figure 25.	Typ. V_{OL} @ $V_{DD} = 3.3$ V (true open drain ports)	76
Figure 26.	Typ. V_{OL} @ $V_{DD} = 5$ V (high sink ports)	76
Figure 27.	Typ. V_{OL} @ $V_{DD} = 3.3$ V (high sink ports)	77
Figure 28.	Typ. $V_{DD-} - V_{OH}$ @ $V_{DD} = 5$ V (standard ports)	77
Figure 29.	Typ. $V_{DD-} - V_{OH}$ @ $V_{DD} = 3.3$ V (standard ports)	77
Figure 30.	Typ. $V_{DD-} - V_{OH}$ @ $V_{DD} = 5$ V (high sink ports)	78
Figure 31.	Typ. $V_{DD-} - V_{OH}$ @ $V_{DD} = 3.3$ V (high sink ports)	78
Figure 32.	Typical NRST V_{IL} and V_{IH} vs V_{DD} @ 4 temperatures	79
Figure 33.	Typical NRST pull-up resistance vs V_{DD} @ 4 temperatures	80
Figure 34.	Typical NRST pull-up current vs V_{DD} @ 4 temperatures	80
Figure 35.	Recommended reset pin protection	81
Figure 36.	SPI timing diagram - slave mode and $CPHA = 0$	82
Figure 37.	SPI timing diagram - slave mode and $CPHA = 1$	83
Figure 38.	SPI timing diagram - master mode ⁽¹⁾	83
Figure 39.	Typical application with I2C bus and timing diagram	85
Figure 40.	ADC accuracy characteristics	88
Figure 41.	Typical application with ADC	88
Figure 42.	TSSOP20 – 20-lead thin shrink small outline, 6.5 x 4.4 mm, 0.65 mm pitch, package outline	92
Figure 43.	TSSOP20 – 20-lead thin shrink small outline, 6.5 x 4.4 mm, 0.65 mm pitch, package footprint	94
Figure 44.	TSSOP20 marking example (package top view)	95
Figure 45.	LQFP32 - 32-pin, 7 x 7 mm low-profile quad flat package outline	96
Figure 46.	LQFP32 - 32-pin, 7 x 7 mm low-profile quad flat package	

	recommended footprint	98
Figure 47.	LQFP32 marking example (package top view)	98
Figure 48.	VFQFPN32 - 32-pin, 5x5 mm, 0.5 mm pitch very thin profile fine pitch quad flat package outline	99
Figure 49.	VFQFPN32 - 32-pin, 5x5 mm, 0.5 mm pitch very thin profile fine pitch quad flat package recommended footprint	101
Figure 50.	VFQFPN32 marking example (package top view)	102

1 Introduction

The datasheet contains the description of STM8AF6213, STM8AF6213A, STM8AF6223, STM8AF6223A and STM8AF6226 features, pinout, electrical characteristics, mechanical data and ordering information.

- For complete information on the STM8A microcontroller memory, registers and peripherals, please refer to STM8S series and STM8AF series 8-bit microcontrollers reference manual (RM0016).
- For information on programming, erasing and protection of the internal Flash memory please refer to the STM8 Flash programming manual (PM0051).
- For information on the debug and SWIM (single wire interface module) refer to the STM8 SWIM communication protocol and debug module user manual (UM0470).
- For information on the STM8 core, please refer to the STM8 CPU programming manual (PM0044).

2 Description

The STM8AF6213, STM8AF6213A, STM8AF6223, STM8AF6223A and STM8AF6226 automotive 8-bit microcontrollers offer 4 to 8 Kbytes of Flash program memory, plus integrated true data EEPROM. The STM8S series and STM8AF series 8-bit microcontrollers reference manual (RM0016) refers to devices in this family as low-density. They provide the following benefits: performance, robustness and reduced system cost.

Device performance and robustness are ensured by advanced core and peripherals made in a state-of-the-art technology, a 16 MHz clock frequency, robust I/Os, independent watchdogs with separate clock source, and a clock security system.

The system cost is reduced thanks to an integrated true data EEPROM for up to 300 k write/erase cycles and a high system integration level with internal clock oscillators, watchdog, and brown-out reset.

Full documentation is offered as well as a wide choice of development tools.

Table 1. STM8AF6213/13A/23/23A/26 features

Device	STM8AF6226	STM8AF6223	STM8AF6223A	STM8AF6213	STM8AF6213A
Pin count	32	20			
Max. number of GPIOs	28 including 21 high-sink I/Os	16 including 12 high-sink I/Os			
Ext. interrupt pins	28	16			
Timer CAPCOM channels	6	7	6	7	6
Timer complementary outputs	3	1	2	1	2
A/D converter channels	7	5	7	5	7
Low-density Flash program memory (byte)	8 K			4 K	
Data EEPROM (byte)	640 ⁽¹⁾				
RAM (byte)	1 K				
Peripheral set	Multipurpose timer (TIM1), SPI, I2C, LINUART, window WDG, independent WDG, ADC, PWM timer (TIM5), 8-bit timer (TIM6)				

1. No read-while-write (RWW) capability.

3 Block diagram

Figure 1. STM8AF6213/13A/23/23A/26 block diagram



MS38343V1

- Legend:** ADC (Analog-to-digital converter), beCAN (Controller area network), BOR (Brownout reset), I²C (Inter-integrated circuit multimaster interface), IWDG (Independent window watchdog), LINUART (Local interconnect network universal asynchronous receiver transmitter), POR (Power on reset), SPI (Serial peripheral interface), SWIM (Single wire interface module), USART (Universal synchronous asynchronous receiver transmitter), Window WDG (Window watchdog).

4 Product overview

The following section intends to give an overview of the basic features of the products covered by this datasheet.

For more detailed information on each feature please refer to STM8S series and STM8AF series 8-bit microcontrollers reference manual (RM0016).

4.1 Central processing unit (CPU)

The 8-bit STM8 core is designed for code efficiency and performance.

It contains 6 internal registers which are directly addressable in each execution context, 20 addressing modes including indexed indirect and relative addressing and 80 instructions.

4.1.1 Architecture and registers

- Harvard architecture
- 3-stage pipeline
- 32-bit wide program memory bus - single cycle fetching for most instructions
- X and Y 16-bit index registers, enabling indexed addressing modes with or without offset and read-modify-write type data manipulations
- 8-bit accumulator
- 24-bit program counter - 16-Mbyte linear memory space
- 16-bit stack pointer - access to a 64 Kbyte level stack
- 8-bit condition code register - 7 condition flags for the result of the last instruction.

4.1.2 Addressing

- 20 addressing modes
- Indexed indirect addressing mode for look-up tables located anywhere in the address space
- Stack pointer relative addressing mode for local variables and parameter passing

4.1.3 Instruction set

- 80 instructions with 2-byte average instruction size
- Standard data movement and logic/arithmetic functions
- 8-bit by 8-bit multiplication
- 16-bit by 8-bit and 16-bit by 16-bit division
- Bit manipulation
- Data transfer between stack and accumulator (push/pop) with direct stack access
- Data transfer using the X and Y registers or direct memory-to-memory transfers

4.2 Single wire interface module (SWIM) and debug module (DM)

The single wire interface module together with an integrated debug module permit non-intrusive, real-time in-circuit debugging and fast memory programming.

4.2.1 SWIM

Single wire interface module for direct access to the debug mode and memory programming. The interface can be activated in all device operation modes. The maximum data transmission speed is 145 byte/ms.

4.2.2 Debug module

The non-intrusive debugging module features a performance close to a full-featured emulator. Besides memory and peripheral operation, CPU operation can also be monitored in real-time by means of shadow registers.

- R/W to RAM and peripheral registers in real-time
- R/W access to all resources by stalling the CPU
- Breakpoints on all program-memory instructions (software breakpoints)
- Two advanced breakpoints, 23 predefined breakpoint configurations

4.3 Interrupt controller

- Nested interrupts with three software priority levels
- 32 interrupt vectors with hardware priority
- Up to 28 external interrupts on 7 vectors including TLI
- Trap and reset interrupts

4.4 Flash program and data EEPROM memory

- Up to 8 Kbytes of Flash program single voltage Flash memory
- 640 byte true data EEPROM
- User option byte area

4.4.1 Write protection (WP)

Write protection of Flash program memory and data EEPROM is provided to avoid unintentional overwriting of memory that could result from a user software malfunction.

There are two levels of write protection. The first level is known as MASS (memory access security system). MASS is always enabled and protects the main Flash program memory, data EEPROM and option byte.

To perform in-application programming (IAP), this write protection can be removed by writing a MASS key sequence in a control register. This allows the application to write to data EEPROM, modify the contents of main program memory or the device option byte.

A second level of write protection, can be enabled to further protect a specific area of memory known as UBC (user boot code). Refer to the figure below.

The size of the UBC is programmable through the UBC option byte, in increments of 1 page (64-byte block) by programming the UBC option byte in ICP mode.

This divides the program memory into two areas:

- Main program memory: up to 8 Kbyte minus UBC
- User-specific boot code (UBC): configurable up to 8 Kbyte

The UBC area remains write-protected during in-application programming. This means that the MASS keys do not unlock the UBC area. It protects the memory used to store the boot program, specific code libraries, reset and interrupt vectors, the reset routine and usually the IAP and communication routines.

Figure 2. Flash memory organization

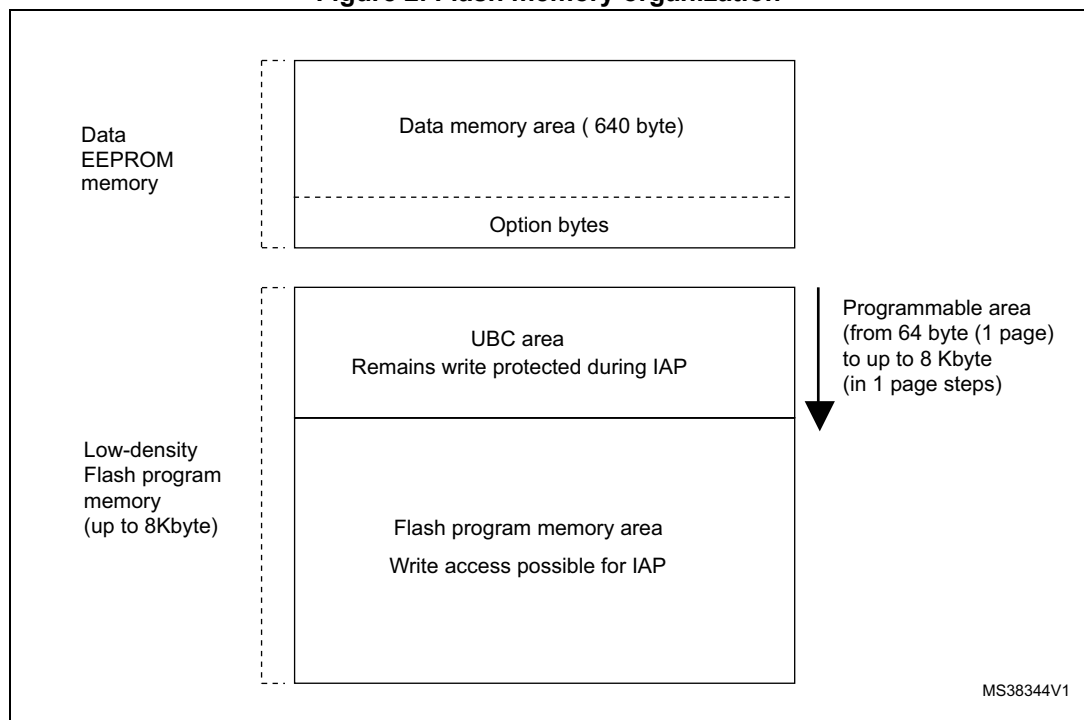

4.4.2 Read-out protection (ROP)

The read-out protection blocks reading and writing the Flash program memory and data EEPROM memory in ICP mode (and debug mode). Once the read-out protection is activated, any attempt to toggle its status triggers a global erase of the program and data memory. Even if no protection can be considered as totally unbreakable, the feature provides a very high level of protection for a general purpose microcontroller.

4.5 Clock controller

The clock controller distributes the system clock (f_{MASTER}) coming from different oscillators to the core and the peripherals. It also manages clock gating for low-power modes and ensures clock robustness.

4.5.1 Features

- **Clock prescaler:** to get the best compromise between speed and current consumption the clock frequency to the CPU and peripherals can be adjusted by a programmable prescaler.
- **Safe clock switching:** Clock sources can be changed safely on the fly in Run mode through a configuration register. The clock signal is not switched until the new clock source is ready. The design guarantees glitch-free switching.
- **Clock management:** To reduce power consumption, the clock controller can stop the clock to the core, individual peripherals or memory.
- **Master clock sources:** four different clock sources can be used to drive the master clock:
 - 1-16 MHz high-speed external crystal (HSE)
 - Up to 16 MHz high-speed user-external clock (HSE user-ext)
 - 16 MHz high-speed internal RC oscillator (HSI)
 - 128 kHz low-speed internal RC (LSI)
- **Startup clock:** after reset, the microcontroller restarts by default with an internal 2 MHz clock (HSI/8). The prescaler ratio and clock source can be changed by the application program as soon as the code execution starts.
- **Clock security system (CSS):** this feature can be enabled by software. If an HSE clock failure occurs, the internal RC (16 MHz/8) is automatically selected by the CSS and an interrupt can optionally be generated.
- **Configurable main clock output (CCO):** This outputs an external clock for use by the application.

Table 2. Peripheral clock gating bit assignments in CLK_PCKENR1/2 registers

Bit	Peripheral clock	Bit	Peripheral clock	Bit	Peripheral clock	Bit	Peripheral clock
PCKEN17	TIM1	PCKEN13	LINUART	PCKEN27	Reserved	PCKEN23	ADC
PCKEN16	TIM5	PCKEN12	Reserved	PCKEN26	Reserved	PCKEN22	AWU
PCKEN15	Reserved	PCKEN11	SPI	PCKEN25	Reserved	PCKEN21	Reserved
PCKEN14	TIM6	PCKEN10	I ² C	PCKEN24	Reserved	PCKEN20	Reserved

4.6 Power management

For efficient power management, the application can be put in one of four different low-power modes. Users can configure each mode to obtain the best compromise between lowest power consumption, fastest start-up time and available wakeup sources.

- **Wait mode:** in this mode, the CPU is stopped but peripherals are kept running. The wakeup is performed by an internal or external interrupt or reset.
- **Active-halt mode with regulator on:** in this mode, the CPU and peripheral clocks are stopped. An internal wakeup is generated at programmable intervals by the auto wake up unit (AWU). The main voltage regulator is kept powered on, so current consumption is higher than in Active-halt mode with regulator off, but the wakeup time is faster. Wakeup is triggered by the internal AWU interrupt, external interrupt or reset.
- **Active-halt mode with regulator off:** this mode is the same as Active-halt with regulator on, except that the main voltage regulator is powered off, so the wake up time is slower.
- **Halt mode:** in this mode the microcontroller uses the least power. The CPU and peripheral clocks are stopped, the main voltage regulator is powered off. Wakeup is triggered by external event or reset.

4.7 Watchdog timers

The watchdog system is based on two independent timers providing maximum security to the applications.

Activation of the watchdog timers is controlled by option bytes or by software. Once activated, the watchdogs cannot be disabled by the user program without performing a reset.

Window watchdog timer

The window watchdog is used to detect the occurrence of a software fault, usually generated by external interferences or by unexpected logical conditions, which cause the application program to abandon its normal sequence.

The window function can be used to trim the watchdog behavior to match the application timing perfectly. The application software must refresh the counter before time-out and during a limited time window.

A reset is generated in two situations:

1. **Timeout:** at 16 MHz CPU clock the time-out period can be adjusted between 75 μ s up to 64 ms.
2. **Refresh out of window:** the downcounter is refreshed before its value is lower than the one stored in the window register.

Independent watchdog timer

The independent watchdog peripheral can be used to resolve processor malfunctions due to hardware or software failures.

It is clocked by the 128 kHz LSI internal RC clock source, and thus stays active even in case of a CPU clock failure.

The IWDG time base spans from 60 μ s to 1 s

4.8 Auto wakeup counter

- Used for auto wakeup from active halt mode
- Clock source: Internal 128 kHz internal low frequency RC oscillator or external clock
- LSI clock can be internally connected to TIM1 input capture channel 1 for calibration

4.9 Beeper

The beeper function outputs a signal on the BEEP pin for sound generation. The signal is in the range of 1, 2 or 4 kHz.

The beeper output port is only available through the alternate function remap option bit AFR7.

4.10 TIM1 - 16-bit advanced control timer

This is a high-end timer designed for a wide range of control applications. With its complementary outputs, dead-time control and center-aligned PWM capability, the field of applications is extended to motor control, lighting and half-bridge driver.

- 16-bit up, down and up/down auto-reload counter with 16-bit fractional prescaler.
- Four independent capture/compare channels (CAPCOM) configurable as input capture, output compare, PWM generation (edge and center aligned mode) and single pulse mode output.
- Synchronization module to control the timer with external signals or to synchronise with TIM5 or TIM6
- Break input to force the timer outputs into a defined state
- Three complementary outputs with adjustable dead time
- Encoder mode
- Interrupt sources: 3 x input capture/output compare, 1 x overflow/update, 1 x break

4.11 TIM5 - 16-bit general purpose timer

- 16-bit autoreload (AR) up-counter
- 15-bit prescaler adjustable to fixed power of 2 ratios 1...32768
- 3 individually configurable capture/compare channels
- PWM mode
- Interrupt sources: 3 x input capture/output compare, 1 x overflow/update
- Synchronization module to control the timer with external signals or to synchronize with TIM1 or TIM6

4.12 TIM6 - 8-bit basic timer

- 8-bit autoreload, adjustable prescaler ratio to any power of 2 from 1 to 128
- Clock source: CPU clock
- Interrupt source: 1 x overflow/update
- Synchronization module to control the timer with external signals or to synchronize with TIM1 or TIM5.

Table 3. TIM timer features

Timer	Counter size (bits)	Prescaler	Counting mode	CAPCOM channels	Complementary outputs	Ext. trigger	Timer synchronization/chaining
TIM1	16	Any integer from 1 to 65536	Up/down	4	3	Yes	Yes
TIM5	16	Any power of 2 from 1 to 32768	Up	3	0	No	
TIM6	8	Any power of 2 from 1 to 128	Up	0	0	No	

4.13 Analog-to-digital converter (ADC1)

The STM8AF6213, STM8AF6213A, STM8AF6223, STM8AF6223A and STM8AF6226 products contain a 10-bit successive approximation A/D converter (ADC1) with up to 7 external and 1 internal multiplexed input channels and the following main features:

- Input voltage range: 0 to V_{DD}
- Input voltage range: 0 to V_{DDA}
- Conversion time: 14 clock cycles
- Single and continuous and buffered continuous conversion modes
- Buffer size ($n \times 10$ bits) where n = number of input channels
- Scan mode for single and continuous conversion of a sequence of channels
- Analog watchdog capability with programmable upper and lower thresholds
- Internal reference voltage on channel AIN7
- Analog watchdog interrupt
- External trigger input
- Trigger from TIM1 TRGO
- End of conversion (EOC) interrupt

Note: Additional AIN12 analog input is not selectable in ADC scan mode or with analog watchdog. Values converted from AIN12 are stored only into the ADC_DRH/ADC_DRL registers.

Internal bandgap reference voltage

Channel AIN7 is internally connected to the internal bandgap reference voltage. The internal bandgap reference is constant and can be used, for example, to monitor V_{DD} . It is independent of variations in V_{DD} and ambient temperature T_A .

4.14 Communication interfaces

The following communication interfaces are implemented:

- LINUART: Full feature UART, synchronous mode, SPI master mode, Smartcard mode, IrDA mode, single wire mode, LIN2.2 capability
- SPI: full and half-duplex, 8 Mbit/s
- I²C: up to 400 Kbit/s

Some peripheral names differ between the datasheet and STM8S series and STM8AF series 8-bit microcontrollers reference manual, RM0016 (see [Table 4](#)).

Table 4. Communication peripheral naming correspondence

Peripheral name in datasheet	Peripheral name in reference manual (RM0016)
LINUART	UART4

4.14.1 LINUART

Main features

- 1 Mbit/s full duplex SCI
- SPI emulation
- High precision baud rate generator
- Smartcard emulation
- IrDA SIR encoder decoder
- LIN mode
- Single wire half duplex mode

LIN mode

Master mode:

- LIN break and delimiter generation
- LIN break and delimiter detection with separate flag and interrupt source for read back checking.

Slave mode:

- Autonomous header handling – one single interrupt per valid header
- Mute mode to filter responses
- Identifier parity error checking
- LIN automatic resynchronization, allowing operation with internal RC oscillator (HSI) clock source
- Break detection at any time, even during a byte reception
- Header errors detection:
 - Delimiter too short
 - Synch field error
 - Deviation error (if automatic resynchronization is enabled)
 - Framing error in synch field or identifier field
 - Header time-out

Asynchronous communication (UART mode)

- Full duplex communication - NRZ standard format (mark/space)
- Programmable transmit and receive baud rates up to 1 Mbit/s ($f_{\text{CPU}}/16$) and capable of following any standard baud rate regardless of the input frequency
- Separate enable bits for transmitter and receiver
- Two receiver wakeup modes:
 - Address bit (MSB)
 - Idle line (interrupt)
- Transmission error detection with interrupt generation
- Parity control

Synchronous communication

- Full duplex synchronous transfers
- SPI master operation
- 8-bit data communication
- Maximum speed: 1 Mbit/s at 16 MHz ($f_{\text{CPU}}/16$)

4.14.2 Serial peripheral interface (SPI)

- Maximum speed: 8 Mbit/s ($f_{\text{MASTER}}/2$) both for master and slave
- Full duplex synchronous transfers
- Simplex synchronous transfers on two lines with a possible bidirectional data line
- Master or slave operation - selectable by hardware or software
- CRC calculation
- 1 byte Tx and Rx buffer
- Slave /master selection input pin

4.14.3 Inter integrated circuit (I²C) interface

- I²C master features:
 - Clock generation
 - Start and stop generation
- I²C slave features:
 - Programmable I²C address detection
 - Stop bit detection
- Generation and detection of 7-bit/10-bit addressing and general call
- Supports different communication speeds:
 - Standard speed (up to 100 kHz),
 - Fast speed (up to 400 kHz)

5 Pinout and pin description

The following table presents the meaning of the abbreviations in use in the pin description tables in this section.

Table 5. Legend/abbreviations for pinout tables

Type	I= input, O = output, S = power supply	
Level	Input	CM = CMOS (standard for all I/Os)
	Output	HS = High sink
Output speed	O1 = Slow (up to 2 MHz) O2 = Fast (up to 10 MHz) O3 = Fast/slow programmability with slow as default state after reset O4 = Fast/slow programmability with fast as default state after reset	
Port and control configuration	Input	float = floating, wpu = weak pull-up
	Output	T = true open drain, OD = open drain, PP = push pull
Reset state	Bold X (pin state after internal reset release). Unless otherwise specified, the pin state is the same during the reset phase and after the internal reset release.	

5.1 TSSOP20 pinouts and pin descriptions

Figure 3. STM8AF6213/STM8AF6223 TSSOP20 pinout

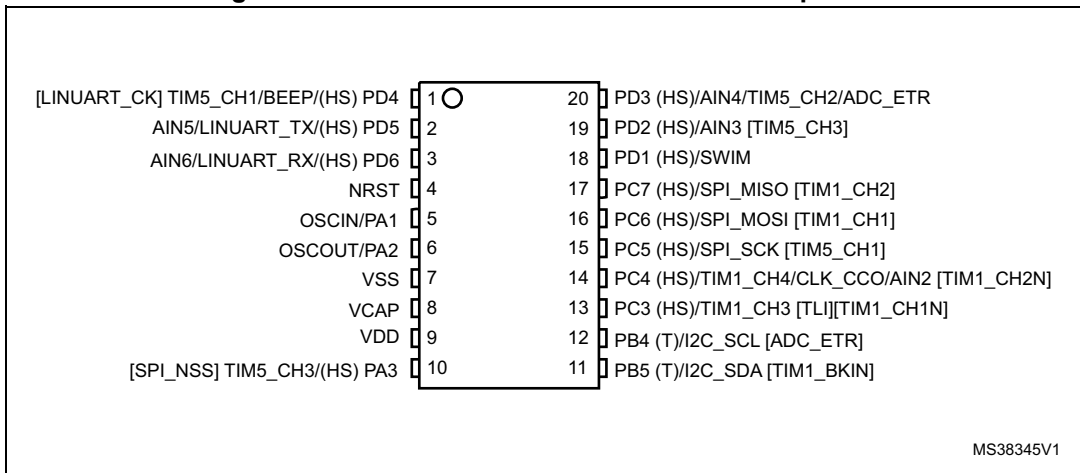

1. (HS) high sink capability.
2. (T) true open drain (P-buffer and protection diode to V_{DD} not implemented).
3. [] alternate function remapping option (if the same alternate function is shown twice, it indicates an exclusive choice not a duplication of the function).

Figure 4. STM8AF6213A and STM8AF6223A TSSOP20 pinout

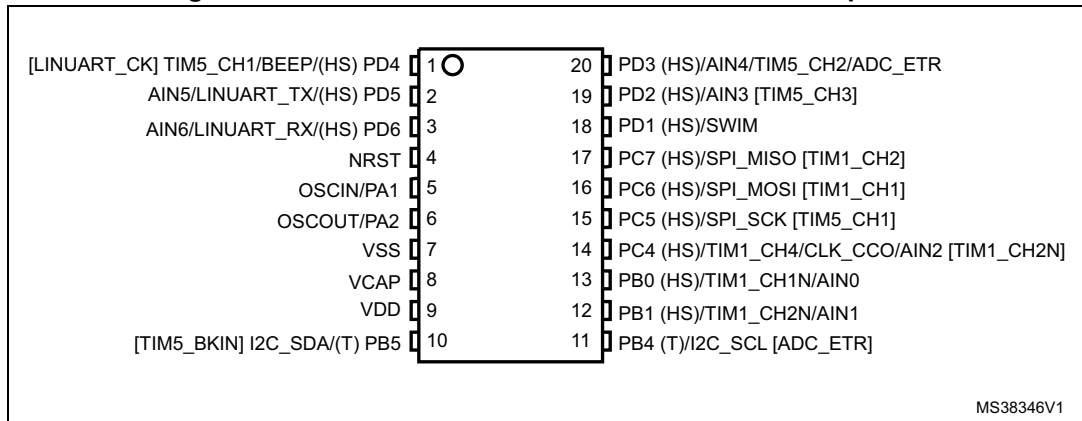

1. (HS) high sink capability.
2. (T) true open drain (P-buffer and protection diode to V_{DD} not implemented).
3. [] alternate function remapping option (if the same alternate function is shown twice, it indicates an exclusive choice not a duplication of the function).

Table 6. STM8AF6213/STM8AF6223 TSSOP20 pin description

TSSOP	Pin name	Type	Input			Output				Main function (after reset)	Default alternate function	Alternate function after remap [option bit]
			floating	wpu	Ext. interrupt	High sink ⁽¹⁾	Speed	OD	PP			
1	PD4/ TIM5_CH1/ BEEP [LINUART_CK]	I/O	X	X	X	HS	O3	X	X	Port D4	Timer 5 - channel 1/BEEP output	LINUART clock [AFR2]
2	PD5/ AIN5/ LINUART_TX	I/O	X	X	X	HS	O3	X	X	Port D5	Analog input 5/ LINUART data transmit	-
3	PD6/ AIN6/ LINUART_RX	I/O	X	X	X	HS	O3	X	X	Port D6	Analog input 6/ LINUART data receive	-
4	NRST	I/O	-	X	-	-	-	-	-	Reset		
5	PA1/ OSCIN ⁽²⁾	I/O	X	X	X	-	O1	X	X	Port A1	Resonator/ crystal in	-
6	PA2/ OSCOUT	I/O	X	X	X	O1	X	X		Port A2	Resonator/ crystal out	-
7	VSS	S	-	-	-	-	-	-	-	Digital ground		
8	VCAP	S	-	-	-	-	-	-	-	1.8 V regulator capacitor		
9	VDD	S	-	-	-	-	-	-	-	Digital power supply		

Table 6. STM8AF6213/STM8AF6223 TSSOP20 pin description (continued)

TSSOP	Pin name	Type	Input			Output				Main function (after reset)	Default alternate function	Alternate function after remap [option bit]
			floating	wpu	Ext. interrupt	High sink ⁽¹⁾	Speed	OD	PP			
10	PA3/ TIM5_CH3 [SPI_NSS]	I/O	X	X	X	HS	O3	X	X	Port A3	Timer 5 channel 3	SPI master/slave select [AFR1]
11	PB5/ I2C_SDA [TIM1_BKIN]	I/O	X	-	X	-	O1	T ⁽³⁾	-	Port B5	I2C data	Timer 1 - break input [AFR4]
12	PB4/ I2C_SCL [ADC_ETR]	I/O	X	-	X	-	O1	T ⁽³⁾	-	Port B4	I2C clock	ADC external trigger [AFR4]
13	PC3/ TIM1_CH3/[TLI]/[TIM1_CH1N]	I/O	X	X	X	HS	O3	X	X	Port C3	Timer 1 - channel 3	Top level interrupt [AFR3] Timer 1 inverted channel 1 [AFR7]
14	PC4/ TIM1_CH4/CLK_CCO/AIN2/[TIM1_CH2N]	I/O	X	X	X	HS	O3	X	X	Port C4	Timer 1 - channel 4 /configurable clock output	Analog input 2 [AFR2] Timer 1 inverted channel 2 [AFR7]
15	PC5/SPI_SCK [TIM5_CH1]	I/O	X	X	X	HS	O3	X	X	Port C5	SPI clock	Timer 5 channel 1 [AFR0]
16	PC6/ SPI_MOSI [TIM1_CH1]	I/O	X	X	X	HS	O3	X	X	Port C6	PI master out/slave in	Timer 1 channel 1 [AFR0]
17	PC7/ SPI_MISO [TIM1_CH2]	I/O	X	X	X	HS	O3	X	X	Port C7	SPI master in/ slave out	Timer 1 channel 2 [AFR0]
18	PD1/ SWIM ⁽⁴⁾	I/O	X	X	X	HS	O4	X	X	Port D1	SWIM data interface	-

Table 6. STM8AF6213/STM8AF6223 TSSOP20 pin description (continued)

TSSOP	Pin name	Type	Input			Output				Main function (after reset)	Default alternate function	Alternate function after remap [option bit]
			floating	wpu	Ext. interrupt	High sink ⁽¹⁾	Speed	OD	PP			
19	PD2/AIN3 [TIM5_CH3]	I/O	X	X	X	HS	O3	X	X	Port D2	-	Analog input 3 [AFR2] Timer 52 - channel 3 [AFR1]
20	PD3/ AIN4/ TIM5_CH2/ ADC_ETR	I/O	X	X	X	HS	O3	X	X	Port D3	Analog input 4 Timer 52 - channel 2/ADC external trigger	-

1. I/O pins used simultaneously for high current source/sink must be uniformly spaced around the package. In addition, the total driven current must respect the absolute maximum ratings (see [Section 10.2: Absolute maximum ratings](#)).
2. When the MCU is in Halt/Active-halt mode, PA1 is automatically configured in input weak pull-up and cannot be used for waking up the device. In this mode, the output state of PA1 is not driven. It is recommended to use PA1 only in input mode if Halt/Active-halt is used in the application.
3. In the open-drain output column, 'T' defines a true open-drain I/O (P-buffer, weak pull-up, and protection diode to VDD are not implemented)
4. The PD1 pin is in input pull-up during the reset phase and after internal reset release.

Table 7. STM8AF6213A and STM8AF6223A TSSOP20 pin description

TSSOP	Pin name	Type	Input			Output				Main function (after reset)	Default alternate function	Alternate function after remap [option bit]
			floating	wpu	Ext. interrupt	High sink ⁽¹⁾	Speed	OD	PP			
1	PD4/ TIM5_CH1/ BEEP/SPI_NSS [LINUART_CK]	I/O	X	X	X	HS	O3	X	X	Port D4	Timer 5 - channel 1/BEEP output	LINUART clock [AFR2]
2	PD5/ AIN5/ LINUART_TX	I/O	X	X	X	HS	O3	X	X	Port D5	Analog input 5/ LINUART data transmit	-

Table 7. STM8AF6213A and STM8AF6223A TSSOP20 pin description (continued)

TSSOP	Pin name	Type	Input			Output				Main function (after reset)	Default alternate function	Alternate function after remap [option bit]
			floating	wpu	Ext. interrupt	High sink ⁽¹⁾	Speed	OD	PP			
3	PD6/ AIN6/ LINUART_RX	I/O	<u>X</u>	X	X	HS	O3	X	X	Port D6	Analog input 6/ LINUART data receive	-
4	NRST	I/O	-	<u>X</u>	-	-	-	-	-	Reset		-
5	PA1/ OSCIN ⁽²⁾	I/O	<u>X</u>	X	X	-	O1	X	X	Port A1	Resonator/ crystal in	-
6	PA2/ OSCOUT	I/O	<u>X</u>	X	X	-	O1	X	X	Port A2	Resonator/ crystal out	-
7	VSS	S	-	-	-	-	-	-	-	Digital ground		-
8	VCAP	S	-	-	-	-	-	-	-	1.8 V regulator capacitor		-
9	VDD	S	-	-	-	-	-	-	-	Digital power supply		-
10	PB5/ I2C_SDA [TIM1_BKIN]	I/O	<u>X</u>	-	X	-	O1	T ⁽³⁾	-	Port B5	I2C data	Timer 1 - break input [AFR4]
11	PB4/ I2C_SCL [ADC_ETR]	I/O	<u>X</u>	-	X	-	O1	T ⁽³⁾	-	Port B4	I2C clock	ADC external trigger [AFR4]
12	PB1/ TIM1_CH2N/ AIN1	I/O	<u>X</u>	X	X	HS	O3	X	X	Port B1	Timer 1 - inverted channel 2/Analog input 1	-
13	PB0/ TIM1_CH1N/AIN0	I/O	<u>X</u>	X	X	HS	O3	X	X	Port B0	Timer 1 - inverted channel 1/Analog input 0	-
14	PC4/ TIM1_CH4/ CLK_CCO/AIN2/[TIM1_CH2]	I/O	<u>X</u>	X	X	HS	O3	X	X	Port C4	Timer 1 - channel 4 /configurabl e clock output	Analog input 2 [AFR2]Time r 1 channel 2 [AFR7]
15	PC5/SPI_SCK [TIM5_CH1]	I/O	<u>X</u>	X	X	HS	O3	X	X	Port C5	SPI clock	Timer 5 channel 1 [AFR0]

Table 7. STM8AF6213A and STM8AF6223A TSSOP20 pin description (continued)

TSSOP	Pin name	Type	Input			Output				Main function (after reset)	Default alternate function	Alternate function after remap [option bit]
			floating	wpu	Ext. interrupt	High sink ⁽¹⁾	Speed	OD	PP			
16	PC6/ SPI_MOSI [TIM1_CH1]	I/O	X	X	X	HS	O3	X	X	Port C6	PI master out/slave in	Timer 1 channel 1 [AFR0]
17	PC7/ SPI_MISO [TIM1_CH2]	I/O	X	X	X	HS	O3	X	X	Port C7	SPI master in/ slave out	Timer 1 channel 2 [AFR0]
18	PD1/ SWIM ⁽⁴⁾	I/O	X	X	X	HS	O4	X	X	Port D1	SWIM data interface	-
19	PD2/AIN3/ TLI[TIM5_CH3]	I/O	X	X	X	HS	O3	X	X	Port D2	-	Analog input 3 [AFR2] Timer 5 - channel 3 [AFR1]
20	PD3/ AIN4/ TIM5_CH2/ ADC_ETR	I/O	X	X	X	HS	O3	X	X	Port D3	Analog input 4 Timer 52 - channel 2/ADC external trigger	-

1. I/O pins used simultaneously for high current source/sink must be uniformly spaced around the package. In addition, the total driven current must respect the absolute maximum ratings (see [Section 10.2: Absolute maximum ratings](#)).
2. When the MCU is in Halt/Active-halt mode, PA1 is automatically configured in input weak pull-up and cannot be used for waking up the device. In this mode, the output state of PA1 is not driven. It is recommended to use PA1 only in input mode if Halt/Active-halt is used in the application.
3. In the open-drain output column, 'T' defines a true open-drain I/O (P-buffer, weak pull-up, and protection diode to VDD are not implemented).
4. The PD1 pin is in input pull-up during the reset phase and after internal reset release.

5.2 LQFP32/VFQPN32 pinout and pin description

Figure 5. STM8AF6226 LQFP32/VFQPN32 pinout

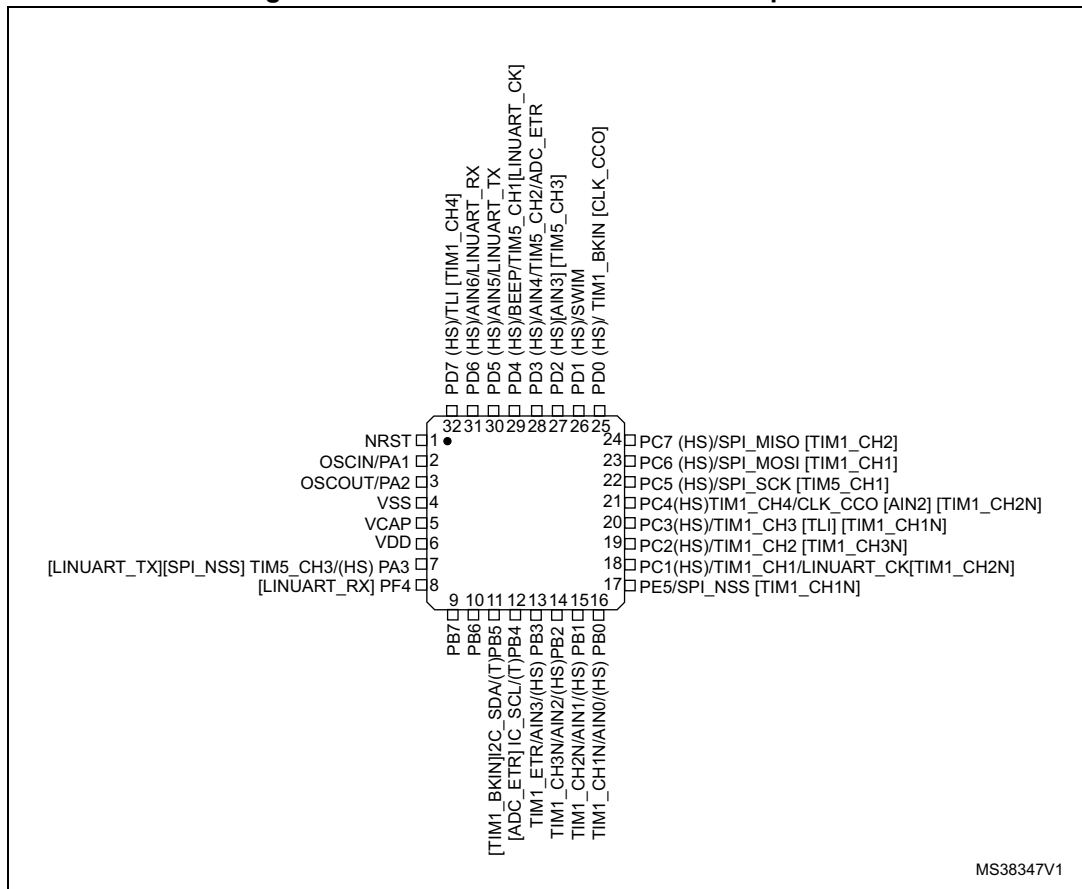

1. (HS) high sink capability.
2. (T) true open drain (P-buffer and protection diode to V_{DD} not implemented).
3. [] alternate function remapping option (if the same alternate function is shown twice, it indicates an exclusive choice not a duplication of the function).

Table 8. STM8AF6226 LQFP32/VFQPN32 pin description

LQFP32 VFQPN32	Pin name	Type	Input			Output				Main function (after reset)	Default alternate function	Alternate function after remap [option bit]
			floating	wpu	Ext. interrupt	High sink ⁽¹⁾	Speed	OD	PP			
1	NRST	I/O	-	X	-	-	-	-	-	Reset		-
2	PA1/ OSCIN ⁽²⁾	I/O	X	X	X	-	O1	X	X	Port A1	Resonator/crystal in	-
3	PA2/ OSCOUT	I/O	X	X	X	-	O1	X	X	Port A2	Resonator/crystal out	-

Table 8. STM8AF6226 LQFP32/VFQPN32 pin description (continued)

LQFP32 VFQPN32	Pin name	Type	Input			Output				Main function (after reset)	Default alternate function	Alternate function after remap [option bit]
			floating	wpu	Ext. interrupt	High sink ⁽¹⁾	Speed	OD	PP			
4	VSS	S	-	-	-	-	-	-	-	Digital ground		-
5	VCAP	S	-	-	-	-	-	-	-	1.8 V regulator capacitor		-
6	VDD	S	-	-	-	-	-	-	-	Digital power supply		-
7	PA3/ TIM5_CH3 [SPI_NSS] [LINUART_TX]	I/O	X	X	X	HS	O3	X	X	Port A3	Timer 52 channel 3	SPI master/ slave select [AFR1]/ LINUART data transmit [AFR1:0]
8	PF4 [LINUART_RX]	I/O	X	X	-	-	O1	X	X	Port F4	LINUART data receive [AFR1:0]	-
9	PB7	I/O	X	X	X	-	O1	X	X	Port B7	-	-
10	PB6	I/O	X	X	X	-	O1	X	X	Port B6	-	-
11	PB5/ I2C_SDA [TIM1_BKIN]	I/O	X	-	X	-	O1	T ⁽³⁾	-	Port B5	I2C data	Timer 1 - break input [AFR4]
12	PB4/ I2C_SCL [ADC_ETR]	I/O	X	-	X	-	O1	T ⁽³⁾	-	Port B4	I2C clock	ADC external trigger [AFR4]
13	PB3/ AIN3/TIM1_ET R	I/O	X	X	X	HS	O3	X	X	Port B3	Analog input 3/ Timer 1 external trigger	-
14	PB2/ AIN2/ TIM1_CH3N	I/O	X	X	X	HS	O3	X	X	Port B2	Analog input 2/ Timer 1 - inverted channel 3	-
15	PB1/ AIN1/ TIM1_CH2N	I/O	X	X	X	HS	O3	X	X	Port B1	Analog input 1/ Timer 1 - inverted channel 2	-
16	PB0/ AIN0/ TIM1_CH1N	I/O	X	X	X	HS	O3	X	X	Port B0	Analog input 0/ Timer 1 - inverted channel 1	-

Table 8. STM8AF6226 LQFP32/VFQPN32 pin description (continued)

LQFP32 VFQPN32	Pin name	Type	Input			Output				Main function (after reset)	Default alternate function	Alternate function after remap [option bit]
			floating	wpu	Ext. interrupt	High sink ⁽¹⁾	Speed	OD	PP			
17	PE5/ SPI_NSS [TIM1_CH1N]	I/O	X	X	X	HS	O3	X	X	Port E5	SPI master/ slave select	Timer 1 - inverted channel 1 [AFR1:0]
18	PC1/ TIM1_CH1/ LINUART_CK [TIM1_CH2N]	I/O	X	X	X	HS	O3	X	X	Port C1	Timer 1 - channel 1 LINUART clock	Timer 1 - inverted channel 2 [AFR1:0]
19	PC2/ TIM1_CH2 [TIM1_CH3N]	I/O	X	X	X	HS	O3	X	X	Port C2	Timer 1 - channel 2	Timer 1 - inverted channel 3 [AFR1:0]
20	PC3/ TIM1_CH3/[TLI] [TIM1_CH1N]	I/O	X	X	X	HS	O3	X	X	Port C3	Timer 1 - channel 3	Top level interrupt [AFR3] Timer 1 inverted channel 1 [AFR7]
21	PC4/ TIM1_CH4/ CLK_CCO/[AIN 2][TIM1_CH2N]	I/O	X	X	X	HS	O3	X	X	Port C4	Timer 1 - channel 4 /configurable clock output	Analog input 2 [AFR2]Timer 1 inverted channel 2 [AFR7]
22	PC5/SPI_SCK [TIM5_CH1]	I/O	X	X	X	HS	O3	X	X	Port C5	SPI clock	Timer 5 channel 1 [AFR0]
23	PC6/ SPI_MOSI [TIM1_CH1]	I/O	X	X	X	HS	O3	X	X	Port C6	PI master out/slave in	Timer 1 channel 1 [AFR0]
24	PC7/ SPI_MISO [TIM1_CH2]	I/O	X	X	X	HS	O3	X	X	Port C7	SPI master in/ slave out	Timer 1 channel 2[AFR0]
25	PD0/ TIM1_BKIN [CLK_CCO]	I/O	X	X	X	HS	O3	X	X	Port D0	Timer 1 - break input	Configurable clock output [AFR5]
26	PD1/ SWIM ⁽⁴⁾	I/O	X	X	X	HS	O4	X	X	Port D1	SWIM data interface	-

Table 8. STM8AF6226 LQFP32/VFQPN32 pin description (continued)

LQFP32 VFQPN32	Pin name	Type	Input			Output				Main function (after reset)	Default alternate function	Alternate function after remap [option bit]
			floating	wpu	Ext. interrupt	High sink ⁽¹⁾	Speed	OD	PP			
27	PD2/[AIN3] [TIM5_CH3]	I/O	X	X	X	HS	O3	X	X	Port D2	-	Analog input 3 [AFR2] Timer 52 - channel 3 [AFR1]
28	PD3/ AIN4/ TIM5_CH2/ ADC_ETR	I/O	X	X	X	HS	O3	X	X	Port D3	Analog input 4 Timer 52 - channel 2/ADC external trigger	-
29	PD4/ TIM5_CH1/ BEEP [LINUART_CK]	I/O	X	X	X	HS	O3	X	X	Port D4	Timer 5 - channel 1/BEEP output	LINUART clock [AFR2]
30	PD5/ AIN5/ LINUART_TX	I/O	X	X	X	HS	O3	X	X	Port D5	Analog input 5/ LINUART data transmit	-
31	PD6/ AIN6/ LINUART_RX	I/O	X	X	X	HS	O3	X	X	Port D6	Analog input 6/ LINUART data receive	-
32	PD7/ TLI [TIM1_CH4]	I/O	X	X	X	HS	O3	X	X	Port D7	Top level interrupt	Timer 1 - channel 4 [AFR6]

1. I/O pins used simultaneously for high current source/sink must be uniformly spaced around the package. In addition, the total driven current must respect the absolute maximum ratings (see [Section 10.2: Absolute maximum ratings](#)).
2. When the MCU is in Halt/Active-halt mode, PA1 is automatically configured in input weak pull-up and cannot be used for waking up the device. In this mode, the output state of PA1 is not driven. It is recommended to use PA1 only in input mode if Halt/Active-halt is used in the application.
3. In the open-drain output column, 'T' defines a true open-drain I/O (P-buffer, weak pull-up, and protection diode to VDD are not implemented).
4. The PD1 pin is in input pull-up during the reset phase and after internal reset release.

5.3 Alternate function remapping

As shown in the rightmost column of [Table 6](#), [Table 7](#) and [Table 8](#) some alternate functions can be remapped at different I/O ports by programming one of eight AFR (alternate function remap) option bits. Refer to [Section 8: Option bytes on page 46](#). When the remapping option is active, the default alternate function is no longer available.

To use an alternate function, the corresponding peripheral must be enabled in the peripheral registers.

Alternate function remapping does not effect GPIO capabilities of the I/O ports (see the GPIO section of STM8S series and STM8AF series 8-bit microcontrollers reference manual, RM0016).

6 Memory and register map

6.1 Memory map

Figure 6. Memory map

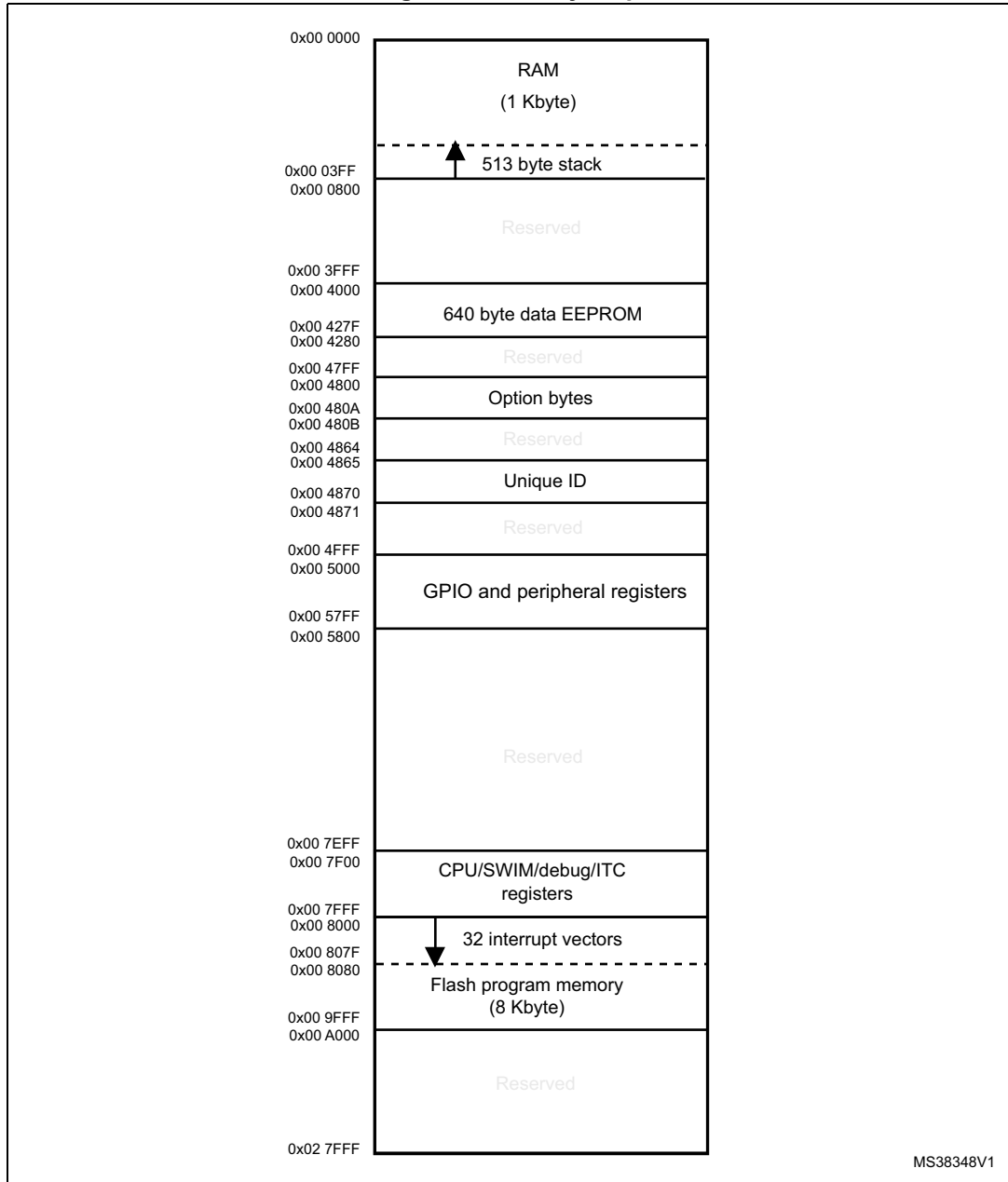

Table 9. Memory model for the devices covered in this datasheet

Flash program memory size	Flash program memory end address	RAM size	RAM end address	Stack roll-over address
8 K	0x00 9FFF	1 K	0x00 03FF	0x00 0200
4 K	0x00 8FFF			

6.2 Register map

6.2.1 I/O port hardware register map

Table 10. I/O port hardware register map

Address	Block	Register label	Register name	Reset status
0x00 5000	Port A	PA_ODR	Port A data output latch register	0x00
0x00 5001		PA_IDR	Port A input pin value register	0xXX ⁽¹⁾
0x00 5002		PA_DDR	Port A data direction register	0x00
0x00 5003		PA_CR1	Port A control register 1	0x00
0x00 5004		PA_CR2	Port A control register 2	0x00
0x00 5005	Port B	PB_ODR	Port B data output latch register	0x00
0x00 5006		PB_IDR	Port B input pin value register	0xXX ⁽¹⁾
0x00 5007		PB_DDR	Port B data direction register	0x00
0x00 5008		PB_CR1	Port B control register 1	0x00
0x00 5009		PB_CR2	Port B control register 2	0x00
0x00 500A	Port C	PC_ODR	Port C data output latch register	0x00
0x00 500B		PC_IDR	Port C input pin value register	0xXX ⁽¹⁾
0x00 500C		PC_DDR	Port C data direction register	0x00
0x00 500D		PC_CR1	Port C control register 1	0x00
0x00 500E		PC_CR2	Port C control register 2	0x00
0x00 500F	Port D	PD_ODR	Port D data output latch register	0x00
0x00 5010		PD_IDR	Port D input pin value register	0xXX ⁽¹⁾
0x00 5011		PD_DDR	Port D data direction register	0x00
0x00 5012		PD_CR1	Port D control register 1	0x02
0x00 5013		PD_CR2	Port D control register 2	0x00

Table 10. I/O port hardware register map (continued)

Address	Block	Register label	Register name	Reset status
0x00 5014	Port E	PE_ODR	Port E data output latch register	0x00
0x00 5015		PE_IDR	Port E input pin value register	0xXX ⁽¹⁾
0x00 5016		PE_DDR	Port E data direction register	0x00
0x00 5017		PE_CR1	Port E control register 1	0x00
0x00 5018		PE_CR2	Port E control register 2	0x00
0x00 5019	Port F	PF_ODR	Port F data output latch register	0x00
0x00 501A		PF_IDR	Port F input pin value register	0xXX ⁽¹⁾
0x00 501B		PF_DDR	Port F data direction register	0x00
0x00 501C		PF_CR1	Port F control register 1	0x00
0x00 501D		PF_CR2	Port F control register 2	0x00

1. Depends on the external circuitry.

Table 11. General hardware register map

Address	Block	Register label	Register name	Reset status
0x00 501E to 0x00 5069	Reserved area (60 byte)			
0x00 505A	Flash	FLASH_CR1	Flash control register 1	0x00
0x00 505B		FLASH_CR2	Flash control register 2	0x00
0x00 505C		FLASH_NCR2	Flash complementary control register 2	0xFF
0x00 505D		FLASH_FPR	Flash protection register	0x00
0x00 505E		FLASH_NFPR	Flash complementary protection register	0xFF
0x00 505F		FLASH_IAPSR	Flash in-application programming status register	0x40
0x00 5060 to 0x00 5061	Reserved area (2 byte)			
0x00 5062	Flash	FLASH_PUKR	Flash Program memory unprotection register	0x00
0x00 5063	Reserved area (1 byte)			
0x00 5064	Flash	FLASH_DUKR	Data EEPROM unprotection register	0x00
0x00 5065 to 0x00 509F	Reserved area (59 byte)			
0x00 50A0	ITC	EXTI_CR1	External interrupt control register 1	0x00
0x00 50A1		EXTI_CR2	External interrupt control register 2	0x00
0x00 50A2 to 0x00 50B2	Reserved area (17 byte)			

Table 11. General hardware register map (continued)

Address	Block	Register label	Register name	Reset status
0x00 50B3	RST	RST_SR	Reset status register	0xXX ⁽¹⁾
0x00 50B4 to 0x00 50BF	Reserved area (12 byte)			
0x00 50C0	CLK	CLK_ICKR	Internal clock control register	0x01
0x00 50C1		CLK_ECKR	External clock control register	0x00
0x00 50C2	Reserved area (1 byte)			
0x00 50C3	CLK	CLK_CMSR	Clock master status register	0xE1
0x00 50C4		CLK_SWR	Clock master switch register	0xE1
0x00 50C5		CLK_SWCR	Clock switch control register	0xFF
0x00 50C6		CLK_CKDIVR	Clock divider register	0x18
0x00 50C7		CLK_PCKENR1	Peripheral clock gating register 1	0xFF
0x00 50C8		CLK_CSSR	Clock security system register	0x00
0x00 50C9		CLK_CCOR	Configurable clock control register	0x00
0x00 50CA		CLK_PCKENR2	Peripheral clock gating register 2	0xFF
0x00 50CB	Reserved area (1 byte)			
0x00 50CC	CLK	CLK_HSITRIMR	HSI clock calibration trimming register	0x00
0x00 50CD		CLK_SWIMCCR	SWIM clock control register	0bXXXX XXX0
0x00 50CE to 0x00 50D0	Reserved area (3 byte)			
0x00 50D1	WWDG	WWDG_CR	WWDG control register	0x7F
0x00 50D2		WWDG_WR	WWDG window register	0x7F
0x00 50D3 to 0x00 50DF	Reserved area (13 byte)			
0x00 50E0	IWDG	IWDG_KR	IWDG key register	0xFF ⁽²⁾
0x00 50E1		IWDG_PR	IWDG prescaler register	0x00
0x00 50E2		IWDG_RLR	IWDG reload register	0xFF
0x00 50E3 to 0x00 50EF	Reserved area (13 byte)			
0x00 50F0	AWU	AWU_CSR1	AWU control/status register 1	0x00
0x00 50F1		AWU_APR	AWU asynchronous prescaler buffer register	0x3F
0x00 50F2		AWU_TBR	AWU timebase selection register	0x00
0x00 50F3	BEEP	BEEP_CSR	BEEP control/status register	0x1F
0x00 50F4 to 0x00 50FF	Reserved area (12 byte)			

Table 11. General hardware register map (continued)

Address	Block	Register label	Register name	Reset status	
0x00 5200	SPI	SPI_CR1	SPI control register 1	0x00	
0x00 5201		SPI_CR2	SPI control register 2	0x00	
0x00 5202		SPI_ICR	SPI interrupt control register	0x00	
0x00 5203		SPI_SR	SPI status register	0x02	
0x00 5204		SPI_DR	SPI data register	0x00	
0x00 5205		SPI_CRCPR	SPI CRC polynomial register	0x07	
0x00 5206		SPI_RXCR	SPI Rx CRC register	0xFF	
0x00 5207		SPI_TXCR	SPI Tx CRC register	0xFF	
0x00 5208 to 0x00 520F		Reserved area (8 byte)			
0x00 5210	I2C	I2C_CR1	I2C control register 1	0x00	
0x00 5211		I2C_CR2	I2C control register 2	0x00	
0x00 5212		I2C_FREQR	I2C frequency register	0x00	
0x00 5213		I2C_OARL	I2C own address register low	0x00	
0x00 5214		I2C_OARH	I2C own address register high	0x00	
0x00 5215		Reserved area (1 byte)			
0x00 5216		I2C_DR	I2C data register	0x00	
0x00 5217		I2C_SR1	I2C status register 1	0x00	
0x00 5218		I2C_SR2	I2C status register 2	0x00	
0x00 5219		I2C_SR3	I2C status register 3	0x00	
0x00 521A		I2C_ITR	I2C interrupt control register	0x00	
0x00 521B		I2C_CCRL	I2C clock control register low	0x00	
0x00 521C		I2C_CCRH	I2C clock control register high	0x00	
0x00 521D		I2C_TRISER	I2C TRISE register	0x02	
0x00 521E		I2C_PECR	I2C packet error checking register	0x00	
0x00 521F to 0x00 522F		Reserved area (17 byte)			

Table 11. General hardware register map (continued)

Address	Block	Register label	Register name	Reset status	
0x00 5230	LINUART	UART4_SR	LINUART status register	0xC0	
0x00 5231		UART4_DR	LINUART data register	0xFF	
0x00 5232		UART4_BRR1	LINUART baud rate register 1	0x00	
0x00 5233		UART4_BRR2	LINUART baud rate register 2	0x00	
0x00 5234		UART4_CR1	LINUART control register 1	0x00	
0x00 5235		UART4_CR2	LINUART control register 2	0x00	
0x00 5236		UART4_CR3	LINUART control register 3	0x00	
0x00 5237		UART4_CR4	LINUART control register 4	0x00	
0x00 5238		Reserved			
0x00 5239		UART4_CR6	LINUART control register 6	0x00	
0x00 523A		UART4_GTR	LINUART guard time register	0x00	
0x00 523B		UART4_PSCR	LINUART prescaler	0x00	
0x00 523C to 0x00 523F		Reserved area (20 byte)			

Table 11. General hardware register map (continued)

Address	Block	Register label	Register name	Reset status
0x00 5250	TIM1	TIM1_CR1	TIM1 control register 1	0x00
0x00 5251		TIM1_CR2	TIM1 control register 2	0x00
0x00 5252		TIM1_SMCR	TIM1 slave mode control register	0x00
0x00 5253		TIM1_ETR	TIM1 external trigger register	0x00
0x00 5254		TIM1_IER	TIM1 Interrupt enable register	0x00
0x00 5255		TIM1_SR1	TIM1 status register 1	0x00
0x00 5256		TIM1_SR2	TIM1 status register 2	0x00
0x00 5257		TIM1_EGR	TIM1 event generation register	0x00
0x00 5258		TIM1_CCMR1	TIM1 capture/compare mode register 1	0x00
0x00 5259		TIM1_CCMR2	TIM1 capture/compare mode register 2	0x00
0x00 525A		TIM1_CCMR3	TIM1 capture/compare mode register 3	0x00
0x00 525B		TIM1_CCMR4	TIM1 capture/compare mode register 4	0x00
0x00 525C		TIM1_CCER1	TIM1 capture/compare enable register 1	0x00
0x00 525D		TIM1_CCER2	TIM1 capture/compare enable register 2	0x00
0x00 525E		TIM1_CNTRH	TIM1 counter high	0x00
0x00 525F		TIM1_CNTRL	TIM1 counter low	0x00
0x00 5260		TIM1_PSCRH	TIM1 prescaler register high	0x00
0x00 5261		TIM1_PSCRL	TIM1 prescaler register low	0x00
0x00 5262		TIM1_ARRH	TIM1 auto-reload register high	0xFF
0x00 5263		TIM1_ARRL	TIM1 auto-reload register low	0xFF
0x00 5264		TIM1_RCR	TIM1 repetition counter register	0x00
0x00 5265		TIM1_CCR1H	TIM1 capture/compare register 1 high	0x00
0x00 5266		TIM1_CCR1L	TIM1 capture/compare register 1 low	0x00
0x00 5267		TIM1_CCR2H	TIM1 capture/compare register 2 high	0x00
0x00 5268		TIM1_CCR2L	TIM1 capture/compare register 2 low	0x00
0x00 5269		TIM1_CCR3H	TIM1 capture/compare register 3 high	0x00
0x00 526A		TIM1_CCR3L	TIM1 capture/compare register 3 low	0x00
0x00 526B		TIM1_CCR4H	TIM1 capture/compare register 4 high	0x00
0x00 526C		TIM1_CCR4L	TIM1 capture/compare register 4 low	0x00
0x00 526D		TIM1_BKR	TIM1 break register	0x00
0x00 526E		TIM1_DTR	TIM1 dead-time register	0x00
0x00 526F		TIM1_OISR	TIM1 output idle state register	0x00
0x00 5270 to 0x00 52FF	Reserved area (147 byte)			

Table 11. General hardware register map (continued)

Address	Block	Register label	Register name	Reset status
0x00 5300	TIM5	TIM5_CR1	TIM5 control register 1	0x00
0x00 5301		TIM5_CR2	TIM5 control register 2	0x00
0x00 5302		TIM5_SMCR	TIM5 slave mode control register	0x00
0x00 5303		TIM5_IER	TIM5 interrupt enable register	0x00
0x00 5304		TIM5_SR1	TIM5 status register 1	0x00
0x00 5305		TIM5_SR2	TIM5 status register 2	0x00
0x00 5306		TIM5_EGR	TIM5 event generation register	0x00
0x00 5307		TIM5_CCMR1	TIM5 capture/compare mode register 1	0x00
0x00 5308		TIM5_CCMR2	TIM5 capture/compare mode register 2	0x00
0x00 5309		TIM5_CCMR3	TIM5 capture/compare mode register 3	0x00
0x00 530A		TIM5_CCER1	TIM5 capture/compare enable register 1	0x00
0x00 530B		TIM5_CCER2	TIM5 capture/compare enable register 2	0x00
00 530C0x		TIM5_CNTRH	TIM5 counter high	0x00
0x00 530D		TIM5_CNTRL	TIM5 counter low	0x00
0x00 530E		TIM5_PSCR	TIM5 prescaler register	0x00
0x00 530F		TIM5_ARRH	TIM5 auto-reload register high	0xFF
0x00 5310		TIM5_ARRL	TIM5 auto-reload register low	0xFF
0x00 5311		TIM5_CCR1H	TIM5 capture/compare register 1 high	0x00
0x00 5312		TIM5_CCR1L	TIM5 capture/compare register 1 low	0x00
0x00 5313		TIM5_CCR2H	TIM5 capture/compare reg. 2 high	0x00
0x00 5314		TIM5_CCR2L	TIM5 capture/compare register 2 low	0x00
0x00 5315		TIM5_CCR3H	TIM5 capture/compare register 3 high	0x00
0x00 5316		TIM5_CCR3L	TIM5 capture/compare register 3 low	0x00
0x00 5317 to 0x00 533F	Reserved area (43 byte)			
0x00 5340	TIM6	TIM6_CR1	TIM6 control register 1	0x00
0x00 5341		TIM6_CR2	TIM6 control register 2	0x00
0x00 5342		TIM6_SMCR	TIM6 slave mode control register	0x00
0x00 5343		TIM6_IER	TIM6 interrupt enable register	0x00
0x00 5344		TIM6_SR	TIM6 status register	0x00
0x00 5345		TIM6_EGR	TIM6 event generation register	0x00
0x00 5346		TIM6_CNTR	TIM6 counter	0x00
0x00 5347		TIM6_PSCR	TIM6 prescaler register	0x00
0x00 5348		TIM6_ARR	TIM6 auto-reload register	0xFF

Table 11. General hardware register map (continued)

Address	Block	Register label	Register name	Reset status
0x00 5349 to 0x00 53DF	Reserved area (153 byte)			
0x00 53E0 to 0x00 53F3	ADC1	ADC_DBxR	ADC data buffer registers	0x00
0x00 53F4 to 0x00 53FF	Reserved area (12 byte)			
0x00 5400	ADC1	ADC_CSR	ADC control/status register	0x00
0x00 5401		ADC_CR1	ADC configuration register 1	0x00
0x00 5402		ADC_CR2	ADC configuration register 2	0x00
0x00 5403		ADC_CR3	ADC configuration register 3	0x00
0x00 5404		ADC_DRH	ADC data register high	0xXX
0x00 5405		ADC_DRL	ADC data register low	0xXX
0x00 5406		ADC_TDRH	ADC Schmitt trigger disable register high	0x00
0x00 5407		ADC_TDRL	ADC Schmitt trigger disable register low	0x00
0x00 5408		ADC_HTRH	ADC high threshold register high	0xFF
0x00 5409		ADC_HTRL	ADC high threshold register low	0x03
0x00 540A		ADC_LTRH	ADC low threshold register high	0x00
0x00 540B		ADC_LTRL	ADC low threshold register low	0x00
0x00 540C		ADC_AWSRH	ADC watchdog status register high	0x00
0x00 540D		ADC_AWSRL	ADC watchdog status register low	0x00
0x00 540E		ADC_AWCRH	ADC watchdog control register high	0x00
0x00 540F		ADC_AWCRL	ADC watchdog control register low	0x00
0x00 5410 to 0x00 57FF	Reserved area (1008 byte)			

1. Depends on the previous reset source.
2. Write only register.

6.2.2 CPU/SWIM/debug module/interrupt controller registers

Table 12. CPU/SWIM/debug module/interrupt controller registers

Address	Block	Register label	Register name	Reset status
0x00 7F00	CPU ⁽¹⁾	A	Accumulator	0x00
0x00 7F01		PCE	Program counter extended	0x00
0x00 7F02		PCH	Program counter high	0x00
0x00 7F03		PCL	Program counter low	0x00
0x00 7F04		XH	X index register high	0x00
0x00 7F05		XL	X index register low	0x00
0x00 7F06		YH	Y index register high	0x00
0x00 7F07		YL	Y index register low	0x00
0x00 7F08		SPH	Stack pointer high	0x03
0x00 7F09		SPL	Stack pointer low	0xFF
0x00 7F0A		CCR	Condition code register	0x28
0x00 7F0B to 0x00 7F5F		Reserved area (85 byte)		
0x00 7F60	CPU	CFG_GCR	Global configuration register	0x00
0x00 7F70	ITC	ITC_SPR1	Interrupt software priority register 1	0xFF
0x00 7F71		ITC_SPR2	Interrupt software priority register 2	0xFF
0x00 7F72		ITC_SPR3	Interrupt software priority register 3	0xFF
0x00 7F73		ITC_SPR4	Interrupt software priority register 4	0xFF
0x00 7F74		ITC_SPR5	Interrupt software priority register 5	0xFF
0x00 7F75		ITC_SPR6	Interrupt software priority register 6	0xFF
0x00 7F76		ITC_SPR7	Interrupt software priority register 7	0xFF
0x00 7F77		ITC_SPR8	Interrupt software priority register 8	0xFF
0x00 7F78 to 0x00 7F79	Reserved area (2 byte)			
0x00 7F80	SWIM	SWIM_CSR	SWIM control status register	0x00
0x00 7F81 to 0x00 7F8F	Reserved area (15 byte)			

Table 12. CPU/SWIM/debug module/interrupt controller registers (continued)

Address	Block	Register label	Register name	Reset status
0x00 7F90	DM	DM_BK1RE	DM breakpoint 1 register extended byte	0xFF
0x00 7F91		DM_BK1RH	DM breakpoint 1 register high byte	0xFF
0x00 7F92		DM_BK1RL	DM breakpoint 1 register low byte	0xFF
0x00 7F93		DM_BK2RE	DM breakpoint 2 register extended byte	0xFF
0x00 7F94		DM_BK2RH	DM breakpoint 2 register high byte	0xFF
0x00 7F95		DM_BK2RL	DM breakpoint 2 register low byte	0xFF
0x00 7F96		DM_CR1	DM debug module control register 1	0x00
0x00 7F97		DM_CR2	DM debug module control register 2	0x00
0x00 7F98		DM_CSR1	DM debug module control/status register 1	0x10
0x00 7F99		DM_CSR2	DM debug module control/status register 2	0x00
0x00 7F9A		DM_ENFCTR	DM enable function register	0xFF
0x00 7F9B to 0x00 7F9F		Reserved area (5 byte)		

1. Accessible by debug module only

7 Interrupt vector mapping

Table 13. Interrupt mapping

Priority	Source block	Description	Wakeup from halt mode	Wakeup from active-halt mode	Interrupt vector address
—	Reset	Reset	Yes	Yes	0x00 8000
—	TRAP	Software interrupt	-	-	0x00 8004
0	TLI	External top level interrupt	-	-	0x00 8008
1	AWU	Auto-wakeup from Halt	-	Yes	0x00 800C
2	Clock controller	Clock controller	-	-	0x00 8010
3	EXTI0	Port A external interrupts	Yes ⁽¹⁾	Yes ⁽¹⁾	0x00 8014
4	EXTI1	Port B external interrupts	Yes	Yes	0x00 8018
5	EXTI2	Port C external interrupts	Yes	Yes	0x00 801C
6	EXTI3	Port D external interrupts	Yes	Yes	0x00 8020
7	EXTI4	Port E external interrupts	Yes	Yes	0x00 8024
8	EXTI5	Port F	-	-	0x00 8028
9	Reserved	-	-	-	0x00 802C
10	SPI	End of transfer	Yes	Yes	0x00 8030
11	TIM1	TIM1 update/overflow/underflow/trigger/break	-	-	0x00 8034
12	TIM1	TIM1 capture/compare	-	-	0x00 8038
13	TIM5	TIM5 update/overflow/trigger	-	-	0x00 803C
14	TIM5	TIM5 capture/compare	-	-	0x00 8040
15	Reserved	-	-	-	0x00 8044
16	Reserved	-	-	-	0x00 8048
17	LINUART	Tx complete	-	-	0x00 804C
18	LINUART	Receive register DATA FULL	-	-	0x00 8050
19	I ² C	I ² C interrupts	Yes	Yes	0x00 8054
20	Reserved	-	-	-	0x00 8058
21	Reserved	-	-	-	0x00 805C
22	ADC1	ADC1 end of conversion/analog watchdog interrupt	-	-	0x00 8060

Table 13. Interrupt mapping (continued)

Priority	Source block	Description	Wakeup from halt mode	Wakeup from active-halt mode	Interrupt vector address
23	TIM6	TIM6 update/overflow/trigger	-	-	0x00 8064
24	Flash	EOP/WR_PG_DIS	-	-	0x00 8068

1. Except PA1.

8 Option bytes

Option bytes contain configurations for device hardware features as well as the memory protection of the device. Except for the ROP (read-out protection) byte, each option byte has to be stored twice, in a regular form (OPTx) and a complemented one (NOPTx) for redundancy.

Option bytes can be modified in ICP mode (via SWIM) by accessing the EEPROM address shown in [Table 14: Option bytes](#) below.

Option bytes can also be modified 'on the fly' by the application in IAP mode, except the ROP and UBC options that can only be modified in ICP mode (via SWIM).

Refer to the STM8 Flash programming manual (PM0051) and STM8 SWIM communication protocol and debug module user manual (UM0470) for information on SWIM programming procedures.

Table 14. Option bytes

Addr.	Option name	Option byte no.	Option bits								Factory default setting
			7	6	5	4	3	2	1	0	
0x00 4800	Read-out protection (ROP)	OPT0	ROP[7:0]								0x00
0x00 4801	User boot code (UBC)	OPT1	UBC[7:0]								0x00
0x00 4802		NOPT1	NUBC[7:0]								0xFF
0x00 4803	Alternate function remapping (AFR)	OPT2	AFR7	AFR6	AFR5	AFR4	AFR3	AFR2	AFR1	AFR0	0x00
0x00 4804		NOPT2	NAFR7	NAFR6	NAFR 5	NAFR 4	NAFR 3	NAFR 2	NAFR 1	NAFR 0	0xFF
0x00 4805	Miscell. option	OPT3	Reserved			HSI TRIM	LSI _EN	IWDG _HW	WWDG _HW	WWDG _HALT	0x00
0x00 4806		NOPT3	Reserved			NHSI TRIM	NLSI _EN	NIWDG _HW	NWWDG _HW	NWWG _HALT	0xFF
0x00 4807	Clock option	OPT4	Reserved			EXT CLK	CKAWU SEL	PRS C1	PRS C0	0x00	
0x00 4808		NOPT4	Reserved			NEXT CLK	NCKAWU SEL	NPRS C1	NPRS C0	0xFF	
0x00 4809	HSE clock startup	OPT5	HSECNT[7:0]								0x00
0x00 480A		NOPT5	NHSECNT[7:0]								0xFF

8.1 Option byte description

Table 15. Option byte description

Option byte no.	Description
OPT0	<p>ROP[7:0]: Memory readout protection (ROP) 0xAA: Enable readout protection (write access via SWIM protocol) <i>Note: Refer to STM8S series and STM8AF series 8-bit microcontrollers reference manual (RM0016) section on Flash/EEPROM memory readout protection for details.</i></p>
OPT1	<p>UBC[7:0]: User boot code area 0x00: No UBC, no write-protection 0x01: Page 0 defined as UBC, memory write-protected 0x02: Page 0 to 1 defined as UBC, memory write-protected Pages 0 and 1 contain the interrupt vectors. ... 0x7F: Pages 0 to 126 defined as UBC, memory write-protected Other values: Page 0 to 127 defined as UBC, memory write-protected. <i>Note: Refer to STM8S series and STM8AF series 8-bit microcontrollers reference manual (RM0016) section on Flash/EEPROM write protection for more details.</i></p>
OPT2	<p>AFR[7:0] Refer to the following sections for the alternate function remapping descriptions of bits [7:2] and [1:0] respectively.</p>
OPT3	<p>HSITRIM: high-speed internal clock trimming register size 0: 3-bit trimming supported in CLK_HSITRIMR register 1: 4-bit trimming supported in CLK_HSITRIMR register</p>
	<p>LSI_EN: low-speed internal clock enable 0: LSI clock is not available as CPU clock source 1: LSI clock is available as CPU clock source</p>
	<p>IWDG_HW: Independent watchdog 0: IWDG independent watchdog activated by software 1: IWDG independent watchdog activated by hardware</p>
	<p>WWDG_HW: Window watchdog activation 0: WWDG window watchdog activated by software 1: WWDG window watchdog activated by hardware</p>
	<p>WWDG_HALT: Window watchdog reset on Halt 0: No reset generated on Halt if WWDG active 1: Reset generated on Halt if WWDG active</p>

Table 15. Option byte description (continued)

Option byte no.	Description
OPT4	EXTCLK: External clock selection 0: External crystal connected to OSCIN/OSCOU 1: External clock signal on OSCIN
	CKAWUSEL: Auto-wakeup unit/clock 0: LSI clock source selected for AWU 1: HSE clock with prescaler selected as clock source for AWU
	PRSC[1:0]: AWU clock prescaler 0x: 16 MHz to 128 kHz prescaler 10: 8 MHz to 128 kHz prescaler 11: 4 MHz to 128 kHz prescaler
OPT5	HSECNT[7:0]: HSE crystal oscillator stabilization time 0x00: 2048 HSE cycles 0xB4: 128 HSE cycles 0xD2: 8 HSE cycles 0xE1: 0.5 HSE cycles

8.2 STM8AF6213/13A/23/23A/26 alternate function remapping bits

Table 16. STM8AF6226 alternate function remapping bits [7:2] for 32-pin packages

Option byte number	Description ⁽¹⁾
OPT2	AFR7: Alternate function remapping option 7 0: AFR7 remapping option inactive: default alternate function ⁽²⁾ 1: Port C3 alternate function = TIM1_CH1N; port C4 alternate function = TIM1_CH2N AFR6: Alternate function remapping option 6 0: AFR6 remapping option inactive: default alternate function ⁽²⁾ 1: Port D7 alternate function = TIM1_CH4. AFR5: Alternate function remapping option 5 0: AFR5 remapping option inactive: default alternate function ⁽²⁾ . 1: Port D0 alternate function = CLK_CCO. AFR4: Alternate function remapping option 4 0: AFR4 remapping option inactive: default alternate function ⁽²⁾ . 1: Port B4 alternate function = ADC_ETR; port B5 alternate function = TIM1_BKIN. AFR3: Alternate function remapping option 3 0: AFR3 remapping option inactive: default alternate function ⁽²⁾ 1: Port C3 alternate function = TLI AFR2: Alternate function remapping option 2 0: AFR2 remapping option inactive: default alternate function ⁽²⁾ 1: Port C4 alternate function = AIN2; port D2 alternate function = AIN3; port D4 alternate function = LINUART_CK

1. Do not use more than one remapping option in the same port.

2. Refer to the pin description.

Table 17. STM8AF6213 and STM8AF6223 alternate function remapping bits [7:2] for 20-pin packages

Option byte number	Description ⁽¹⁾
OPT2	<p>AFR7: Alternate function remapping option 7 0: AFR7 remapping option inactive: default alternate function ⁽²⁾ 1: Port C3 alternate function = TIM1_CH1N; port C4 alternate function = TIM1_CH2N</p> <p>AFR6: Alternate function remapping option 6 Reserved</p> <p>AFR5: Alternate function remapping option 5 Reserved</p> <p>AFR4: Alternate function remapping option 4 0: AFR4 remapping option inactive: default alternate function ⁽²⁾. 1: Port B4 alternate function = ADC_ETR; port B5 alternate function = TIM1_BKIN.</p> <p>AFR3: Alternate function remapping option 3 0: AFR3 remapping option inactive: default alternate function ⁽²⁾ 1: Port C3 alternate function = TLI</p> <p>AFR2: Alternate function remapping option 2 0: AFR2 remapping option inactive: default alternate function ⁽²⁾ 1: Port D4 alternate function = LINUART_CK</p>

1. Do not use more than one remapping option in the same port.
2. Refer to the pin description.

Table 18. STM8AF6213A and STM8AF6223A alternate function remapping bits [7:2] for 20-pin packages

Option byte number	Description ⁽¹⁾
OPT2	<p>AFR7: Alternate function remapping option 7 0: AFR7 remapping option inactive: default alternate function ⁽²⁾ 1: Port C4 alternate function = TIM1_CH2N</p> <p>AFR6: Alternate function remapping option 6 Reserved</p> <p>AFR5: Alternate function remapping option 5 Reserved</p> <p>AFR4: Alternate function remapping option 4 0: AFR4 remapping option inactive: default alternate function ⁽²⁾. 1: Port B4 alternate function = ADC_ETR; port B5 alternate function = TIM1_BKIN.</p> <p>AFR3: Alternate function remapping option 3 Reserved.</p> <p>AFR2: Alternate function remapping option 2 0: AFR2 remapping option inactive: default alternate function ⁽²⁾ 1: Port D4 alternate function = LINUART_CK</p>

1. Do not use more than one remapping option in the same port.
2. Refer to the pin description.

Table 19. STM8AF6226 alternate function remapping bits [1:0] for 32-pin packages

AFR1 option bit value	AFR0 option bit value	I/O port	Alternate function mapping
0	0	AFR1 and AFR0 remapping options inactive: Default alternate functions ⁽¹⁾	
0	1	PC5	TIM5_CH1
		PC6	TIM1_CH1
		PC7	TIM1_CH2
1	0	PA3	SPI_NSS
		PD2	TIM5_CH3
1 ⁽²⁾	1 ⁽²⁾	PD2	TIM5_CH3
		PC5	TIM5_CH1
		PC6	TIM1_CH1
		PC7	TIM1_CH2
		PC2	TIM1_CH3N
		PC1	TIM1_CH2N
		PE5	TIM1_CH1N
		PA3	LINUART_TX
PF4	LINUART_RX		

1. Refer to the pin descriptions.
2. If both AFR1 and AFR0 option bits are set, the SPI hardware NSS management feature is no more available. If this remapping option is selected and the SPI is enabled, the SSM bit must be configured in the SPI_CR2 register to select software NSS management.

Table 20. STM8AF6213/STM8AF6223 alternate function remapping bits [1:0] for 20-pin packages

AFR1 option bit value	AFR0 option bit value	I/O port	Alternate function mapping
0	0	AFR1 and AFR0 remapping options inactive: Default alternate functions ⁽¹⁾	
0	1	PC5	TIM5_CH1
		PC6	TIM1_CH1
		PC7	TIM1_CH2
1	0	PA3	SPI_NSS
		PD2	TIM5_CH3

Table 20. STM8AF6213/STM8AF6223 alternate function remapping bits [1:0] for 20-pin packages (continued)

AFR1 option bit value	AFR0 option bit value	I/O port	Alternate function mapping
1	1	PD2	TIM5_CH3
		PC5	TIM5_CH1
		PC6	TIM1_CH1
		PC7	TIM1_CH2
		PC2	Not available
		PC1	Not available
		PE5	Not available
		PA3	SPI_NSS
		PF4	Not available

1. Refer to the pin descriptions.

Table 21. STM8AF6223A alternate function remapping bits [1:0] for 20-pin packages

AFR1 option bit value	AFR0 option bit value	I/O port	Alternate function mapping
0	0	AFR1 and AFR0 remapping options inactive: Default alternate functions ⁽¹⁾	
0	1	PC5	TIM5_CH1
		PC6	TIM1_CH1
		PC7	TIM1_CH2
1	0	PA3	Not available
		PD2	TIM5_CH3
1 ⁽²⁾	1 ⁽²⁾	PD2	TIM5_CH3
		PC5	TIM5_CH1
		PC6	TIM1_CH1
		PC7	TIM1_CH2
		PC2	Not available
		PC1	Not available
		PE5	Not available
		PA3	Not available
		PF4	Not available

1. Refer to the pin descriptions.

2. If both AFR1 and AFR0 option bits are set, the SPI hardware NSS management feature is no more available. If this remapping option is selected and the SPI is enabled, the SSM bit must be configured in the SPI_CR2 register to select software NSS management.

9 Unique ID

The devices feature a 96-bit unique device identifier which provides a reference number that is unique for any device and in any context. The 96 bits of the identifier can never be altered by the user.

The unique device identifier can be read in single byte and may then be concatenated using a custom algorithm.

The unique device identifier is ideally suited:

- For use as serial numbers
- For use as security keys to increase the code security in the program memory while using and combining this unique ID with software cryptographic primitives and protocols before programming the internal memory.
- To activate secure boot processes.

Table 22. Unique ID bit description

Address	Content description	Unique ID bits							
		7	6	5	4	3	2	1	0
0x4865	X coordinate on the wafer	U_ID[7:0]							
0x4866		U_ID[15:8]							
0x4867	Y coordinate on the wafer	U_ID[23:16]							
0x4868		U_ID[31:24]							
0x4869	Wafer number	U_ID[39:32]							
0x486A	Lot number	U_ID[47:40]							
0x486B		U_ID[55:48]							
0x486C		U_ID[63:56]							
0x486D		U_ID[71:64]							
0x486E		U_ID[79:72]							
0x486F		U_ID[87:80]							
0x4870		U_ID[95:88]							

10 Electrical characteristics

10.1 Parameter conditions

Unless otherwise specified, all voltages are referred to V_{SS} .

10.1.1 Minimum and maximum values

Unless otherwise specified the minimum and maximum values are guaranteed in the worst conditions of ambient temperature, supply voltage and frequencies by tests in production on 100% of the devices with an ambient temperature at $T_A = -40\text{ }^\circ\text{C}$, $T_A = 25\text{ }^\circ\text{C}$, and $T_A = T_{Amax}$ (given by the selected temperature range).

Data based on characterization results, design simulation and/or technology characteristics are indicated in the table footnotes and are not tested in production.

10.1.2 Typical values

Unless otherwise specified, typical data are based on $T_A = 25\text{ }^\circ\text{C}$, $V_{DD} = 5.0\text{ V}$. They are given only as design guidelines and are not tested.

Typical ADC accuracy values are determined by characterization of a batch of samples from a standard diffusion lot over the full temperature range.

10.1.3 Typical curves

Unless otherwise specified, all typical curves are given only as design guidelines and are not tested.

10.1.4 Loading capacitor

The loading conditions used for pin parameter measurement are shown in [Figure 7](#).

Figure 7. Pin loading conditions

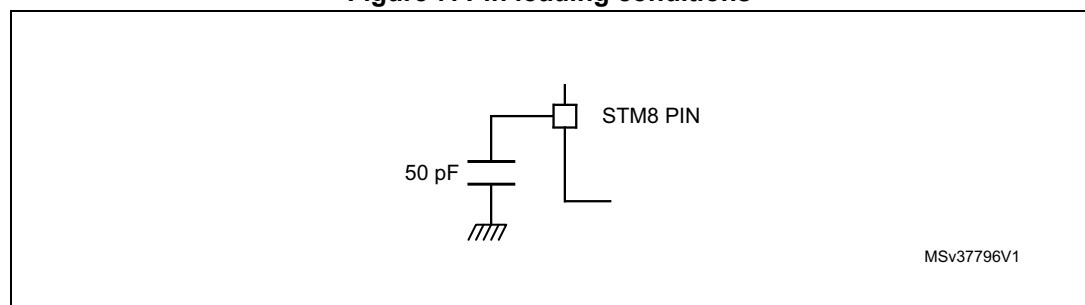

10.1.5 Pin input voltage

The input voltage measurement on a pin of the device is described in [Figure 8](#).

Figure 8. Pin input voltage

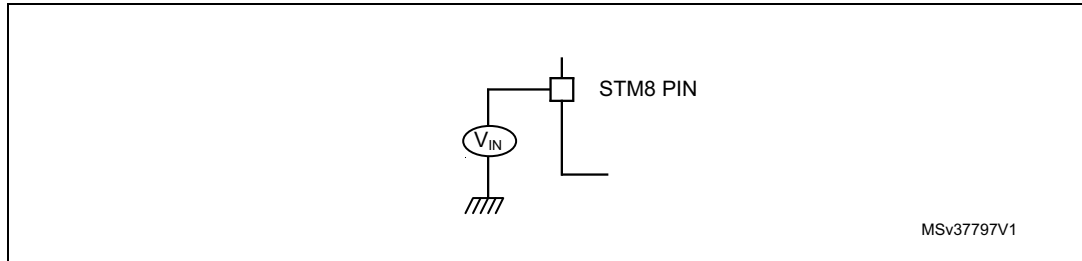

10.2 Absolute maximum ratings

Stresses above the absolute maximum ratings listed in [Table 23: Voltage characteristics](#), [Table 24: Current characteristics](#) and [Table 25: Thermal characteristics](#) may cause permanent damage to the device. These are stress ratings only and functional operation of the device at these conditions is not implied. Exposure to maximum rating conditions for extended periods may affect the device’s reliability.

Device mission profile (application conditions) is compliant with JEDEC JESD47 Qualification Standard, extended mission profiles are available on demand.

Table 23. Voltage characteristics

Symbol	Ratings	Min	Max	Unit
$V_{DDx} - V_{SS}$	Supply voltage (including V_{DDA} and V_{DDIO}) ⁽¹⁾	-0.3	6.5	V
V_{IN}	Input voltage on true open drain pins ⁽²⁾	$V_{SS} - 0.3$	6.5	V
	Input voltage on any other pin ⁽²⁾	$V_{SS} - 0.3$	$V_{DD} + 0.3$	
$ V_{DDx} - V_{DD} $	Variations between different power pins	-	50	mV
$ V_{SSx} - V_{SS} $	Variations between all the different ground pins	-	50	
V_{ESD}	Electrostatic discharge voltage	see Absolute maximum ratings (electrical sensitivity) on page 90		

1. All power (V_{DD}) and ground (V_{SS}) pins must always be connected to the external power supply
2. $I_{INJ(PIN)}$ must never be exceeded. This is implicitly insured if V_{IN} maximum is respected. If V_{IN} maximum cannot be respected, the injection current must be limited externally to the $I_{INJ(PIN)}$ value. A positive injection is induced by $V_{IN} > V_{DD}$ while a negative injection is induced by $V_{IN} < V_{SS}$. For true open-drain pads, there is no positive injection current, and the corresponding V_{IN} maximum must always be respected

Table 24. Current characteristics

Symbol	Ratings	Max. ⁽¹⁾	Unit
I_{VDD}	Total current into V_{DD} power lines (source) ⁽²⁾	100	mA
I_{VSS}	Total current out of V_{SS} ground lines (sink) ⁽²⁾	80	
I_{IO}	Output current sunk by any I/O and control pin	20	
	Output current source by any I/Os and control pin	-20	
$I_{INJ(PIN)}^{(3) (4)}$	Injected current on RST pin	±4	
	Injected current on OSCIN pin	±4	
	Injected current on any other pin ⁽⁵⁾	±4	
$\sum I_{INJ(TOT)}^{(3)}$	Total injected current (sum of all I/O and control pins) ⁽⁵⁾	±20	

1. Guaranteed by characterization results.
2. All power (V_{DD} , V_{DDIO} , V_{DDA}) and ground (V_{SS} , V_{SSIO} , V_{SSA}) pins must always be connected to the external supply.
3. $I_{INJ(PIN)}$ must never be exceeded. This is implicitly insured if V_{IN} maximum is respected. If V_{IN} maximum cannot be respected, the injection current must be limited externally to the $I_{INJ(PIN)}$ value. A positive injection is induced by $V_{IN} > V_{DD}$ while a negative injection is induced by $V_{IN} < V_{SS}$. For true open-drain pads, there is no positive injection current, and the corresponding V_{IN} maximum must always be respected.
4. ADC accuracy vs. negative injection current: Injecting negative current on any of the analog input pins should be avoided as this significantly reduces the accuracy of the conversion being performed on another analog input. It is recommended to add a Schottky diode (pin to ground) to standard analog pins which may potentially inject negative current. Any positive injection current within the limits specified for $I_{INJ(PIN)}$ and $\sum I_{INJ(PIN)}$ in the I/O port pin characteristics section does not affect the ADC accuracy
5. When several inputs are submitted to a current injection, the maximum $\sum I_{INJ(PIN)}$ is the absolute sum of the positive and negative injected currents (instantaneous values). These results are based on characterization with $\sum I_{INJ(PIN)}$ maximum current injection on four I/O port pins of the device.

Table 25. Thermal characteristics

Symbol	Ratings	Value	Unit
T_{STG}	Storage temperature range	-65 to 150	°C
T_J	Maximum junction temperature	150	

Table 26. Operating lifetime (OLF)

Symbol	Ratings	Value	Unit
OLF	Conforming to AEC-Q100	-40 to 150	°C

10.3 Operating conditions

Table 27. General operating conditions

Symbol	Parameter	Conditions	Min	Max	Unit
f_{CPU}	Internal CPU clock frequency	-	0	16	MHz
V_{DD}	Standard operating voltage	-	3.0	5.5	V
$V_{CAP}^{(1)}$	C_{EXT} : capacitance of external capacitor	-	470	3300	nF
	ESR of external capacitor	at 1 MHz ⁽²⁾	-	0.3	Ω
	ESL of external capacitor		-	15	nH
$P_D^{(3)}$	Power dissipation at $T_A = 85\text{ }^\circ\text{C}$ for suffix A version, $T_A = 125\text{ }^\circ\text{C}$ for suffix C version, $T_A = 150\text{ }^\circ\text{C}$ for suffix D version	TSSOP20	-	45	mW
		LQFP32	-	83	
		VQFPN32	-	TBD	-
T_A	Ambient temperature for suffix A version	Maximum power dissipation	-40	85	$^\circ\text{C}$
	Ambient temperature for suffix C version		-40	125	
	Ambient temperature for suffix D version		-40	150	
T_J	Junction temperature range	Suffix A	-40	90	
		Suffix C	-40	130	
		Suffix D	-40	155	

- Care should be taken when selecting the capacitor, due to its tolerance, as well as the parameter dependency on temperature, DC bias and frequency in addition to other factors. The parameter maximum value must be respected for the full application range.
- This frequency of 1 MHz as a condition for V_{CAP} parameters is given by design of internal regulator.
- See [Section 11.4: Thermal characteristics](#).

Figure 9. f_{CPUmax} versus V_{DD}

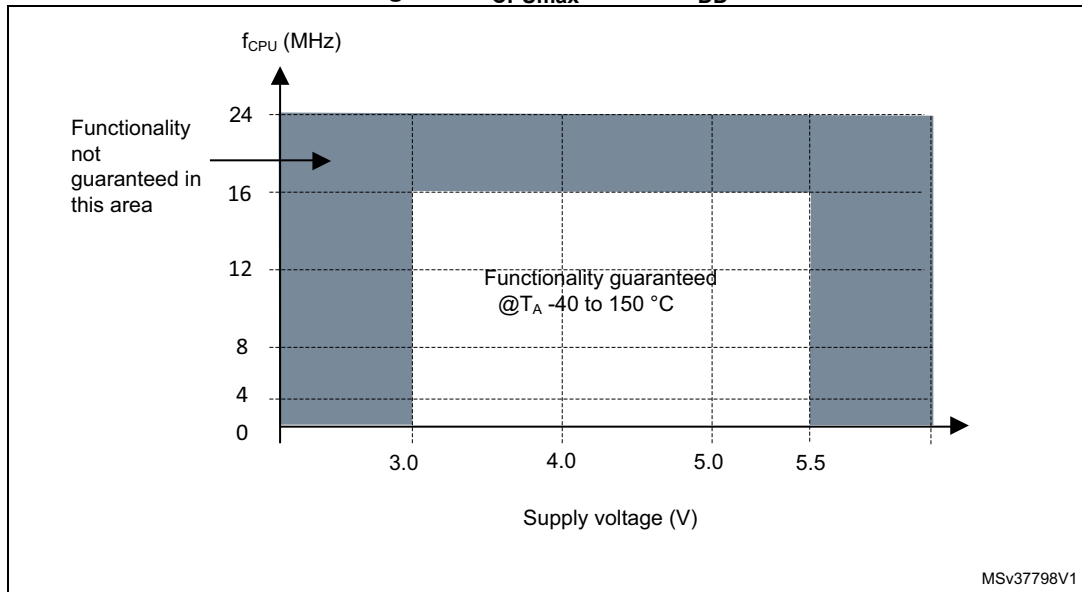

Table 28. Operating conditions at power-up/power-down

Symbol	Parameter	Conditions	Min	Typ	Max	Unit
t_{VDD}	V_{DD} rise time rate	-	2 ⁽¹⁾	-	∞	$\mu\text{s/V}$
	V_{DD} fall time rate ⁽²⁾	-	2 ⁽¹⁾	-	∞	
t_{TEMP}	Reset release delay	V_{DD} rising	-	-	1.7	ms
V_{IT+}	Power-on reset threshold ⁽³⁾	-	2.6 ⁽¹⁾	2.7	2.85	V
V_{IT-}	Brown-out reset threshold	-	2.5	2.65	2.8 ⁽¹⁾	
$V_{HYS(BOR)}$	Brown-out reset hysteresis	-	-	70 ⁽¹⁾	-	mV

1. Guaranteed by design.
2. Reset is always generated after a t_{TEMP} delay. The application must ensure that V_{DD} is still above the minimum operating voltage ($V_{DD\ min}$) when the t_{TEMP} delay has elapsed.
3. There is inrush current into V_{DD} present after device power on to charge C_{EXT} capacitor. This inrush energy depends from C_{EXT} capacitor value. For example, a C_{EXT} of 1 μF requires $Q=1\ \mu\text{F} \times 1.8\text{V} = 1.8\ \mu\text{C}$.

10.3.1 VCAP external capacitor

Stabilization for the main regulator is achieved connecting an external capacitor C_{EXT} to the V_{CAP} pin. C_{EXT} is specified in [Table 27](#). Care should be taken to limit the series inductance to less than 15 nH.

Figure 10. External capacitor C_{EXT}

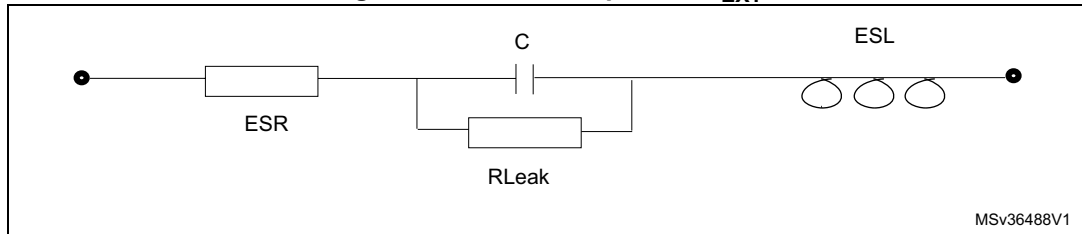

- Legend: ESR is the equivalent series resistance and ESL is the equivalent inductance.

10.3.2 Supply current characteristics

The current consumption is measured as described in [Section 4.3: Interrupt controller](#).

Total current consumption in run mode

The MCU is placed under the following conditions:

- All I/O pins in input mode with a static value at V_{DD} or V_{SS} (no load)
- All peripherals are disabled (clock stopped by peripheral clock gating registers) except if explicitly mentioned.

Subject to general operating conditions for V_{DD} and T_A .

Unless otherwise specified, data are based on characterization results, and not tested in production.

Table 29. Total current consumption with code execution in run mode at $V_{DD} = 5 V$

Symbol	Parameter	Conditions	Typ	Max	Unit	
$I_{DD(RUN)}$	Supply current in run mode, code executed from RAM	$f_{CPU} = f_{MASTER} = 16 \text{ MHz}$	HSE crystal osc. (16 MHz)	2.3	-	mA
			HSE user ext. clock (16 MHz)	2	2.35	
			HSI RC osc. (16 MHz)	1.7	2 ⁽¹⁾	
		$f_{CPU} = f_{MASTER}/128 = 125 \text{ kHz}$	HSE user ext. clock (16 MHz)	0.86	-	
			HSI RC osc. (16 MHz)	0.7	0.87	
		$f_{CPU} = f_{MASTER}/128 = 15.625 \text{ kHz}$	HSI RC osc. (16 MHz/8)	0.46	0.58	
		$f_{CPU} = f_{MASTER} = 28 \text{ kHz}$	LSI RC osc. (128 kHz)	0.41	0.55	

Table 29. Total current consumption with code execution in run mode at V_{DD} = 5 V (continued)

Symbol	Parameter	Conditions		Typ	Max	Unit
I _{DD(RUN)}	Supply current in run mode, code executed from Flash	f _{CPU} = f _{MASTER} = 16 MHz	HSE crystal osc. (16 MHz)	4.5	-	mA
			HSE user ext. clock (16 MHz)	4.3	4.75	
			HSI RC osc. (16 MHz)	3.7	4.5 ⁽¹⁾	
	Supply current in run mode, code executed from Flash	f _{CPU} = f _{MASTER} = 2 MHz	HSI RC osc. (16 MHz/8) ⁽²⁾	0.84	2 ⁽¹⁾	
		f _{CPU} = f _{MASTER} /128 = 125 kHz	HSI RC osc. (16 MHz)	0.72	0.9	
		f _{CPU} = f _{MASTER} /128 = 15.625 kHz	HSI RC osc. (16 MHz/8)	0.46	0.58	
		f _{CPU} = f _{MASTER} = 128 kHz	LSI RC osc. (128 kHz)	0.42	0.57	

1. Tested in production.
2. Default clock configuration measured with all peripherals off.

Table 30. Total current consumption with code execution in run mode at V_{DD} = 3.3 V

Symbol	Parameter	Conditions		Typ	Max ⁽¹⁾	Unit	
I _{DD(RUN)}	Supply current in run mode, code executed from RAM	f _{CPU} = f _{MASTER} = 16 MHz	HSE crystal osc. (16 MHz)	1.8	-	mA	
			HSE user ext. clock (16 MHz)	2	2.3		
			HSI RC osc. (16 MHz)	1.5	2		
		f _{CPU} = f _{MASTER} /128 = 125 kHz	HSE user ext. clock (16 MHz)	0.81	-		
			HSI RC osc. (16 MHz)	0.7	0.87		
			HSI RC osc. (16 MHz/8)	0.46	0.58		
		f _{CPU} = f _{MASTER} = 128 kHz	LSI RC osc. (128 kHz)	0.41	0.55		
		Supply current in run mode, code executed from Flash	f _{CPU} = f _{MASTER} = 16 MHz	HSE crystal osc. (16 MHz)	4		-
				HSE user ext. clock (16 MHz)	3.9		4.7
	HSI RC osc. (16 MHz)			3.7	4.5		
	f _{CPU} = f _{MASTER} = 2 MHz		HSI RC osc. (16 MHz/8) ⁽²⁾	0.84	1.05		
	f _{CPU} = f _{MASTER} /128 = 125 kHz		HSI RC osc. (16 MHz)	0.72	0.9		
	f _{CPU} = f _{MASTER} /128 = 15.625 kHz		HSI RC osc. (16 MHz/8)	0.46	0.58		
	f _{CPU} = f _{MASTER} = 128 kHz		LSI RC osc. (128 kHz)	0.42	0.57		

1. Guaranteed by characterization results.
2. Default clock configuration measured with all peripherals off.

Total current consumption in wait mode

Unless otherwise specified, data based are on characterization results, and not tested in production.

Table 31. Total current consumption in wait mode at V_{DD} = 5 V

Symbol	Parameter	Conditions		Typ	Max	Unit
I _{DD(WFI)}	Supply current in wait mode	f _{CPU} = f _{MASTER} = 16 MHz	HSE crystal osc. (16 MHz)	1.6	-	mA
			HSE user ext. clock (16 MHz)	1.1	1.3	
			HSI RC osc. (16 MHz)	0.89	1.5 ⁽¹⁾	
		f _{CPU} = f _{MASTER} /128 = 125 kHz	HSI RC osc. (16 MHz)	0.7	0.88	
		f _{CPU} = f _{MASTER} /128 = 15.625 kHz	HSI RC osc. (16 MHz/8) ⁽²⁾	0.45	0.57	
		f _{CPU} = f _{MASTER} = 128 kHz	LSI RC osc. (128 kHz)	0.4	0.54	

1. Tested in production.
2. Default clock configuration measured with all peripherals off.

Table 32. Total current consumption in wait mode at V_{DD} = 3.3 V

Symbol	Parameter	Conditions		Typ	Max ⁽¹⁾	Unit
I _{DD(WFI)}	Supply current in wait mode	f _{CPU} = f _{MASTER} = 16 MHz	HSE crystal osc. (16 MHz)	1.1	-	mA
			HSE user ext. clock (16 MHz)	1.1	1.3	
			HSI RC osc. (16 MHz)	0.89	1.1	
		f _{CPU} = f _{MASTER} /128 = 125 kHz	HSI RC osc. (16 MHz)	0.7	0.88	
		f _{CPU} = f _{MASTER} /128 = 15.625 kHz	HSI RC osc. (16 MHz/8) ⁽²⁾	0.45	0.57	
		f _{CPU} = f _{MASTER} = 128 kHz	LSI RC osc. (128 kHz)	0.4	0.54	

1. Guaranteed by characterization results.
2. Default clock configuration measured with all peripherals off.

Total current consumption in active halt mode

Table 33. Total current consumption in active halt mode at V_{DD} = 5 V

Symbol	Parameter	Conditions			Typ	Max at 85°C	Max at 125°C	Max at 150°C	Unit
		Main voltage regulator (MVR) ⁽¹⁾	Flash mode ⁽²⁾	Clock source					
I _{DD(AH)}	Supply current in active halt mode	On	Operating mode	HSE crystal osc. (16 MHz)	1030	-	-	-	µA
				LSI RC osc. (128 kHz)	200	260	300	-	
			Power-down mode	HSE crystal osc. (16 MHz)	970	-	-	-	
				LSI RC osc. (128 kHz)	150	200	230	-	
		Off	Operating mode	LSI RC osc. (128 kHz)	66	85	140	200	
			Power-down mode	LSI RC osc. (128 kHz)	10	20	40	-	

1. Configured by the REGAH bit in the CLK_ICKR register.
2. Configured by the AHALT bit in the FLASH_CR1 register.

Table 34. Total current consumption in active halt mode at V_{DD} = 3.3 V

Symbol	Parameter	Conditions			Typ	Max at 85°C ⁽¹⁾	Max at 125°C	Unit
		Main voltage regulator (MVR) ⁽²⁾	Flash mode ⁽³⁾	Clock source				
I _{DD(AH)}	Supply current in active halt mode	On	Operating mode	HSE crystal osc. (16 MHz)	550	-	-	µA
				LSI RC osc. (128 kHz)	200	260	290	
			Power-down mode	HSE crystal osc. (16 MHz)	970	-	-	
				LSI RC osc. (128 kHz)	150	200	230	
		Off	Operating mode	LSI RC osc. (128 kHz)	66	80	105	
			Power-down mode	LSI RC osc. (128 kHz)	10	18	35	

1. Guaranteed by characterization results.
2. Configured by the REGAH bit in the CLK_ICKR register.
3. Configured by the AHALT bit in the FLASH_CR1 register.

Total current consumption in halt mode

Table 35. Total current consumption in halt mode at V_{DD} = 5 V

Symbol	Parameter	Conditions	Typ	Max at 85°C	Max at 125°C	Max at 150°C	Unit
I _{DD(H)}	Supply current in halt mode	Flash in operating mode, HSI clock after wakeup	63	75	105	-	μA
		Flash in power-down mode, HSI clock after wakeup	6.0	20 ⁽¹⁾	55 ⁽¹⁾	80 ⁽¹⁾	

1. Tested in production.

Table 36. Total current consumption in halt mode at V_{DD} = 3.3 V

Symbol	Parameter	Conditions	Typ	Max at 85°C ⁽¹⁾	Max at 125°C ⁽¹⁾	Unit
I _{DD(H)}	Supply current in halt mode	Flash in operating mode, HSI clock after wakeup	60	75	100	μA
		Flash in power-down mode, HSI clock after wakeup	4.5	17	30	

1. Guaranteed by characterization results.

Low-power mode wakeup times

Table 37. Wakeup times

Symbol	Parameter	Conditions			Typ	Max ⁽¹⁾	Unit
t _{WU(WFI)}	Wakeup time from wait mode to run mode ⁽²⁾	0 to 16 MHz			-	See ⁽³⁾	
		f _{CPU} = f _{MASTER} = 16 MHz			0.56	-	
t _{WU(AH)}	Wakeup time active halt mode to run mode ⁽²⁾	MVR voltage regulator on ⁽⁴⁾	Flash in operating mode ⁽⁵⁾	HSI (after wakeup)	1 ⁽⁶⁾	2 ⁽⁶⁾	μs
					3 ⁽⁶⁾	-	
		MVR voltage regulator off			48 ⁽⁶⁾	-	
					50 ⁽⁶⁾	-	
t _{WU(H)}	Wakeup time from halt mode to run mode ⁽²⁾	Flash in operating mode ⁽⁵⁾			52	-	
		Flash in power-down mode ⁽⁵⁾			54	-	

1. Guaranteed by design.
2. Measured from interrupt event to interrupt vector fetch.
3. t_{WU(WFI)} = 2 x 1/f_{MASTER}+ 67 x 1/f_{CPU}.
4. Configured by the REGAH bit in the CLK_ICKR register.
5. Configured by the AHALT bit in the FLASH_CR1 register.
6. Plus 1 LSI clock depending on synchronization.

Total current consumption and timing in forced reset state**Table 38. Total current consumption and timing in forced reset state**

Symbol	Parameter	Conditions	Typ	Max ⁽¹⁾	Unit
I _{DD(R)}	Supply current in reset state ⁽²⁾	V _{DD} = 5 V	400	-	μA
		V _{DD} = 3.3 V	300	-	
t _{RESETBL}	Reset pin release to vector fetch	-	-	150	μs

1. Guaranteed by design.
2. Characterized with all I/Os tied to V_{SS}.

Current consumption for on-chip peripherals

Subject to general operating conditions for V_{DD} and T_A.

HSI internal RC/f_{CPU} = f_{MASTER} = 16 MHz, V_{DD} = 5 V

Table 39. Peripheral current consumption

Symbol	Parameter	Typ	Unit
I _{DD(TIM1)}	TIM1 supply current ⁽¹⁾	210	μA
I _{DD(TIM5)}	TIM5 supply current ⁽¹⁾	130	
I _{DD(TIM6)}	TIM6 supply current ⁽¹⁾	50	
I _{DD(UART1)}	LINUART supply current ⁽²⁾	120	
I _{DD(SPI)}	SPI supply current ⁽²⁾	45	
I _{DD(I2C)}	I2C supply current ⁽²⁾	65	
I _{DD(ADC1)}	ADC1 supply current ⁽³⁾	1000	

1. Data based on a differential I_{DD} measurement between reset configuration and timer counter running at 16 MHz. No IC/OC programmed (no I/O pads toggling). Not tested in production.
2. Data based on a differential I_{DD} measurement between the on-chip peripheral when kept under reset and not clocked and the on-chip peripheral when clocked and not kept under reset. No I/O pads toggling. Not tested in production.
3. Data based on a differential I_{DD} measurement between reset configuration and continuous A/D conversions. Not tested in production.

Current consumption curves

The following figures show typical current consumption measured with code executing in RAM.

Figure 11. Typ $I_{DD(RUN)}$ vs. V_{DD} HSE user external clock, $f_{CPU} = 16$ MHz

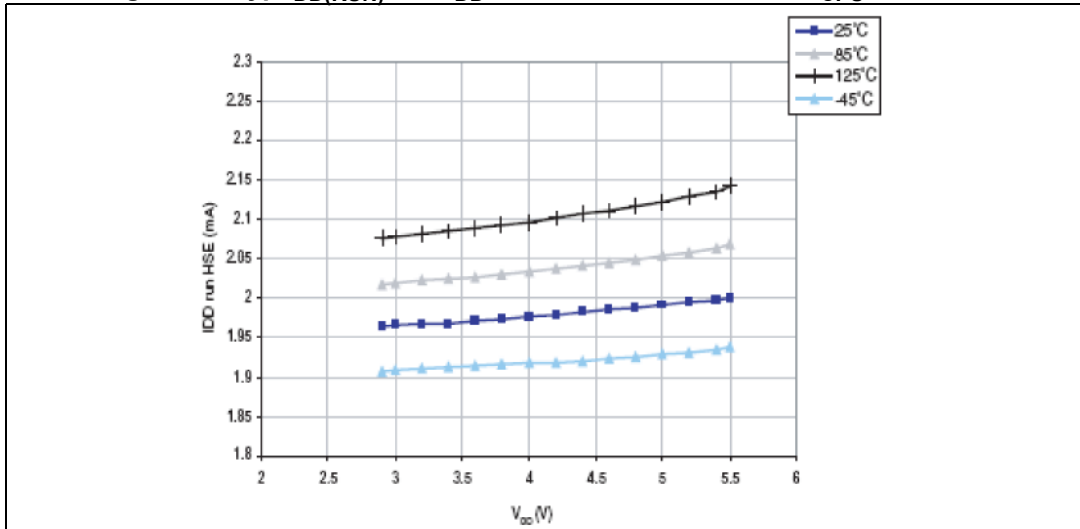

Figure 12. Typ $I_{DD(RUN)}$ vs. f_{CPU} HSE user external clock, $V_{DD} = 5$ V

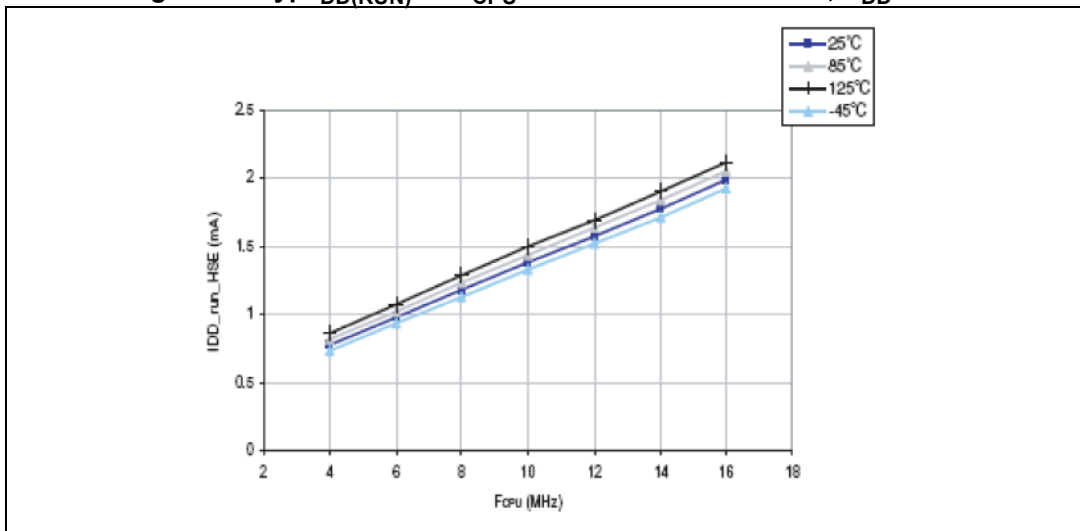

Figure 13. Typ $I_{DD(RUN)}$ vs. V_{DD} HSEI RC osc., $f_{CPU} = 16$ MHz

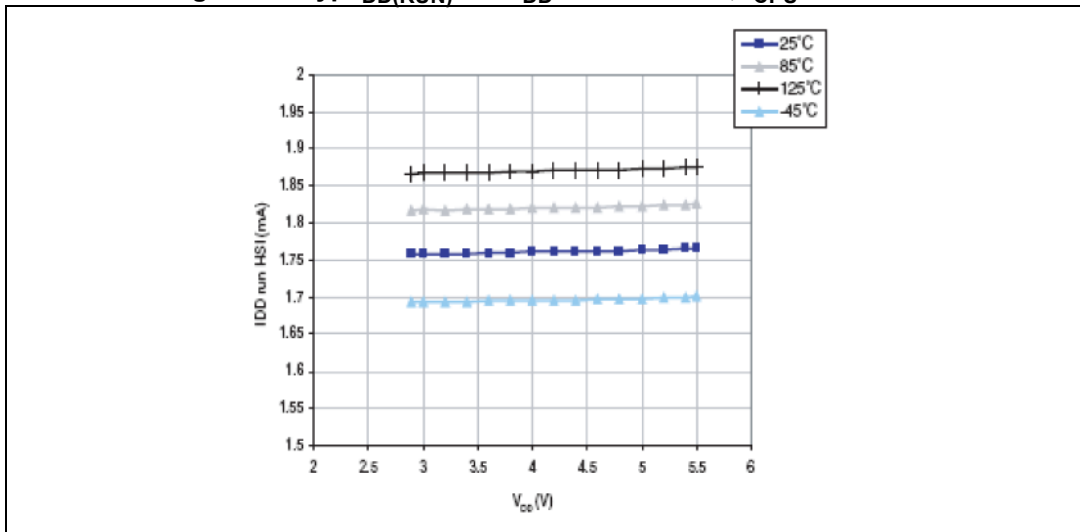

Figure 14. Typ $I_{DD(WFI)}$ vs. V_{DD} HSE user external clock, $f_{CPU} = 16$ MHz



Figure 15. Typ $I_{DD(WFI)}$ vs. f_{CPU} HSE user external clock, $V_{DD} = 5\text{ V}$



Figure 16. Typ $I_{DD(WFI)}$ vs. V_{DD} HSI RC osc., $f_{CPU} = 16\text{ MHz}$



10.3.3 External clock sources and timing characteristics

HSE user external clock

Subject to general operating conditions for V_{DD} and T_A .

Table 40. HSE user external clock characteristics

Symbol	Parameter	Conditions	Min	Typ	Max	Unit
f_{HSE_ext}	User external clock source frequency	-	0	-	16	MHz
$V_{HSEH}^{(1)}$	OSCIN input pin high level voltage	-	$0.7 \times V_{DD}$	-	$V_{DD} + 0.3 V$	V
$V_{HSEL}^{(1)}$	OSCIN input pin low level voltage	-	V_{SS}	-	$0.3 \times V_{DD}$	
I_{LEAK_HSE}	OSCIN input leakage current	$V_{SS} < V_{IN} < V_{DD}$	-1	-	+1	μA

1. Guaranteed by characterization results.

Figure 17. HSE external clock source

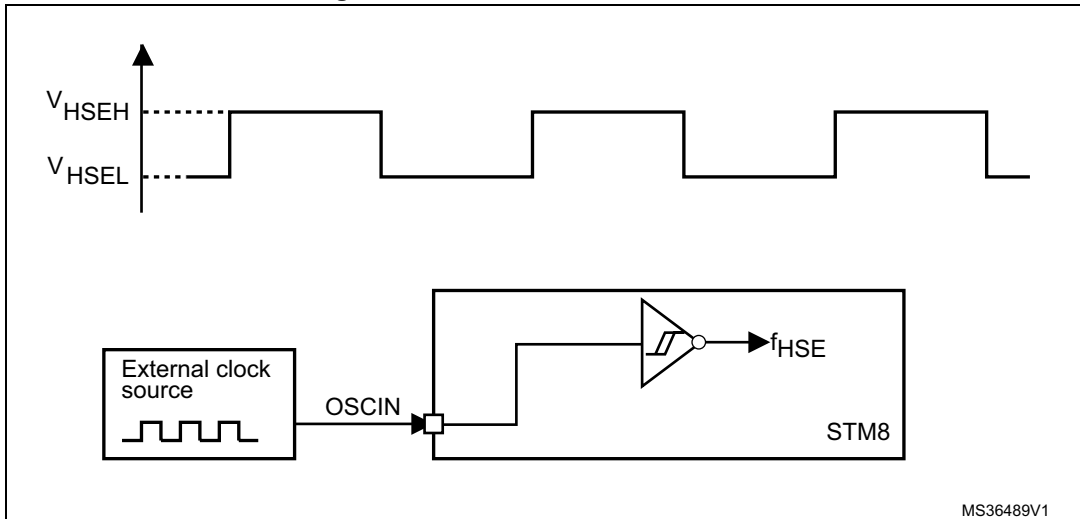

MS36489V1

HSE crystal/ceramic resonator oscillator

The HSE clock can be supplied with a 1 to 16 MHz crystal/ceramic resonator oscillator. All the information given in this paragraph is based on characterization results with specified typical external components. In the application, the resonator and the load capacitors have to be placed as close as possible to the oscillator pins in order to minimize output distortion and startup stabilization time. Refer to the crystal resonator manufacturer for more details (frequency, package, accuracy...).

Table 41. HSE oscillator characteristics

Symbol	Parameter	Conditions	Min	Typ	Max	Unit
f_{HSE}	External high-speed oscillator frequency	-	1	-	16	MHz
R_F	Feedback resistor	-	-	220	-	k Ω
$C^{(1)}$	Recommended load capacitance ⁽²⁾	-	-	-	20	pF
$I_{DD(HSE)}$	HSE oscillator power consumption	$C = 20$ pF, $f_{OSC} = 16$ MHz	-	-	6 (startup) 1.6 (stabilized) ⁽³⁾	mA
		$C = 10$ pF, $f_{OSC} = 16$ MHz	-	-	6 (startup) 1.2 (stabilized) ⁽³⁾	
g_m	Oscillator transconductance	-	5	-	-	mA/V
$t_{SU(HSE)}^{(4)}$	Startup time	V_{DD} is stabilized	-	1	-	ms

1. C is approximately equivalent to 2 x crystal C_{LOAD} .
2. The oscillator selection can be optimized in terms of supply current using a high quality resonator with small R_m value. Refer to the crystal manufacturer for more details.
3. Guaranteed by characterization results.
4. $t_{SU(HSE)}$ is the startup time measured from the moment it is enabled (by software) until a stabilized 16 MHz oscillation is reached. The value is measured for a standard crystal resonator and it can vary significantly with the crystal manufacturer.

Figure 18. HSE oscillator circuit diagram

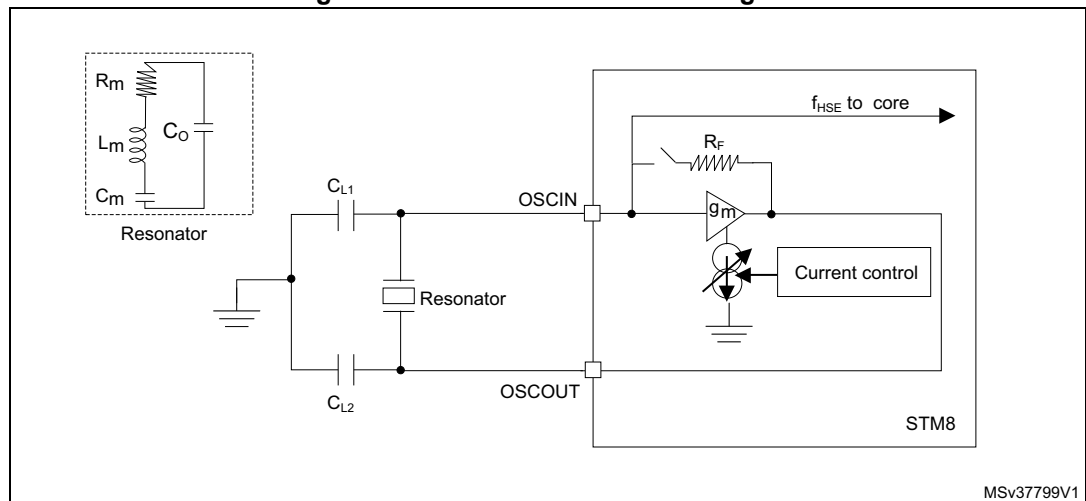

HSE oscillator critical g_m formula

The crystal characteristics have to be checked with the following formula:

$$g_m \gg g_{m\text{crit}}$$

where $g_{m\text{crit}}$ can be calculated with the crystal parameters as follows:

$$g_{m\text{crit}} = (2 \times \Pi \times f_{\text{HSE}})^2 \times R_m(2C_o + C)^2$$

- R_m : Notional resistance (see crystal specification)
- L_m : Notional inductance (see crystal specification)
- C_m : Notional capacitance (see crystal specification)
- C_o : Shunt capacitance (see crystal specification)
- $C_{L1} = C_{L2} = C$: Grounded external capacitance

10.3.4 Internal clock sources and timing characteristics

Subject to general operating conditions for V_{DD} and T_A .

High speed internal RC oscillator (HSI)

Table 42. HSI oscillator characteristics

Symbol	Parameter	Conditions	Min	Typ	Max	Unit	
f_{HSI}	Frequency	-	-	16	-	MHz	
ACC_{HS}	HSI oscillator user trimming accuracy	Trimmed by the application for any V_{DD} and T_A conditions	3-bit calibration	-1 ⁽¹⁾	-	1 ⁽¹⁾	%
			4-bit calibration	-0.5 ⁽¹⁾	-	0.5 ⁽¹⁾	
	HSI oscillator accuracy (factory calibrated)	3.0 V ≤ V_{DD} ≤ 5.5 V, -40 °C ≤ T_A ≤ 150 °C	-5	-	5		
3.0 V ≤ V_{DD} ≤ 5.5 V, -40 °C ≤ T_A ≤ 125 °C			-3 ⁽²⁾	-	3 ⁽²⁾		
$t_{\text{su(HSI)}}$	HSI oscillator wakeup time	-	-	-	2 ⁽³⁾	μs	
$I_{\text{DD(HSI)}}$	HSI oscillator power consumption	-	-	170	250 ⁽³⁾	μA	

1. Selection between legacy 3-bit calibration and 4-bit extended calibration is done using the HSITRIM bit in OPT3 and NOPT3. To achieve a higher accuracy, 4-bit calibration must be enabled.
2. These values are guaranteed for STM8AF62xxlxx order codes only.
3. Guaranteed by characterization results.

Low speed internal RC oscillator (LSI)

Subject to general operating conditions for V_{DD} and T_A .

Table 43. LSI oscillator characteristics

Symbol	Parameter	Conditions	Min	Typ	Max	Unit
f_{LSI}	Frequency	-	110 ⁽¹⁾	128	150 ⁽¹⁾	kHz
$t_{su(LSI)}$	LSI oscillator wakeup time	-	-	-	7	μ s
$I_{DD(LSI)}$	LSI oscillator power consumption	-	-	5	-	μ A

1. Tested in production.

10.3.5 Memory characteristics

RAM and hardware registers

Table 44. RAM and hardware registers

Symbol	Parameter	Conditions	Min	Unit
V_{RM}	Data retention mode ⁽¹⁾	Halt mode (or reset)	V_{IT-max} ⁽²⁾	V

1. Minimum supply voltage without losing the data stored in RAM (in halt mode or under reset) or in hardware registers (only in halt mode). Guaranteed by design.

2. Refer to the operating conditions for the value of V_{IT-max}

Flash program memory/data EEPROM memory

General conditions: $T_A = -40$ to 150 °C.

Table 45. Flash program memory/data EEPROM memory

Symbol	Parameter	Conditions	Min	Typ	Max	Unit
V_{DD}	Operating voltage (all modes, execution/write/erase)	f_{CPU} is 0 to 16 MHz with 0 ws	3.0	-	5.5	V
	Operating voltage (code execution)		2.6	-	5.5	
t_{prog}	Standard programming time (including erase) for byte/word/block (1 byte/4 byte/64 byte)	-	-	6.0	6.6	ms
	Fast programming time for 1 block (64 byte)	-	-	3.0	3.3	
t_{ERASE}	Erase time for 1 block (64 byte)	-	-	3.0	3.3	

Table 46. Flash program memory

Symbol	Parameter	Condition	Min	Max	Unit
T _{WE}	Temperature for writing and erasing	-	-40	150	°C
N _{WE}	Flash program memory endurance (erase/write cycles) ⁽¹⁾	T _A = 25 °C	1000	-	cycles
t _{RET}	Data retention time	T _A = 25 °C	40	-	years
		T _A = 55 °C	20	-	

1. The physical granularity of the memory is 4 byte, so cycling is performed on 4 byte even when a write/erase operation addresses a single byte.

Table 47. Data memory

Symbol	Parameter	Condition	Min	Max	Unit
T _{WE}	Temperature for writing and erasing	-	-40	150	°C
N _{WE}	Data memory endurance ⁽¹⁾ (erase/write cycles)	T _A = 25 °C	300 k	-	cycles
		T _A = -40°C to 125 °C	100 k ⁽²⁾	-	
t _{RET}	Data retention time	T _A = 25 °C	40 ⁽³⁾	-	years
		T _A = 55 °C	20 ⁽²⁾⁽³⁾	-	

1. The physical granularity of the memory is 4 byte, so cycling is performed on 4 byte even when a write/erase operation addresses a single byte.

2. More information on the relationship between data retention time and number of write/erase cycles is available in a separate technical document.

3. Retention time for 256B of data memory after up to 1000 cycles at 125 °C.

10.3.6 I/O port pin characteristics

General characteristics

Subject to general operating conditions for V_{DD} and T_A unless otherwise specified. All unused pins must be kept at a fixed voltage, using the output mode of the I/O for example or an external pull-up or pull-down resistor.

Table 48. I/O static characteristics

Symbol	Parameter	Conditions	Min	Typ	Max	Unit
V_{IL}	Input low level voltage	-	-0.3 V	-	$0.3 \times V_{DD}$	V
V_{IH}	Input high level voltage		$0.7 \times V_{DD}$	-	$V_{DD} + 0.3 \text{ V}$	
V_{hys}	Hysteresis ⁽¹⁾		-	700	-	mV
R_{pu}	Pull-up resistor	$V_{DD} = 5 \text{ V}, V_{IN} = V_{SS}$	35	55	80	k Ω
t_R, t_F	Rise and fall time (10% - 90%)	Fast I/Os Load = 50 pF	-	-	$35^{(2)}$	ns
		Standard and high sink I/Os Load = 50 pF	-	-	$125^{(2)}$	
		Fast I/Os Load = 20 pF			$20^{(2)}$	
		Standard and high sink I/Os Load = 20 pF			$50^{(2)}$	
I_{lkg}	Digital input pad leakage current	$V_{SS} \leq V_{IN} \leq V_{DD}$	-	-	$\pm 1^{(3)}$	μA
$I_{lkg \text{ ana}}$	Analog input pad leakage current	$V_{SS} \leq V_{IN} \leq V_{DD}$ $-40 \text{ }^\circ\text{C} < T_A < 125 \text{ }^\circ\text{C}$	-	-	$\pm 250^{(3)}$	nA
		$V_{SS} \leq V_{IN} \leq V_{DD}$ $-40 \text{ }^\circ\text{C} < T_A < 150 \text{ }^\circ\text{C}$	-	-	$\pm 500^{(3)}$	
$I_{lkg(inj)}$	Leakage current in adjacent I/O ⁽²⁾	Injection current $\pm 4 \text{ mA}$	-	-	$\pm 1^{(3)}$	μA

1. Hysteresis voltage between Schmitt trigger switching levels. Guaranteed by characterization results.
2. Guaranteed by characterization results.
3. Guaranteed by design.

Figure 19. Typical V_{IL} and V_{IH} vs V_{DD} @ 4 temperatures

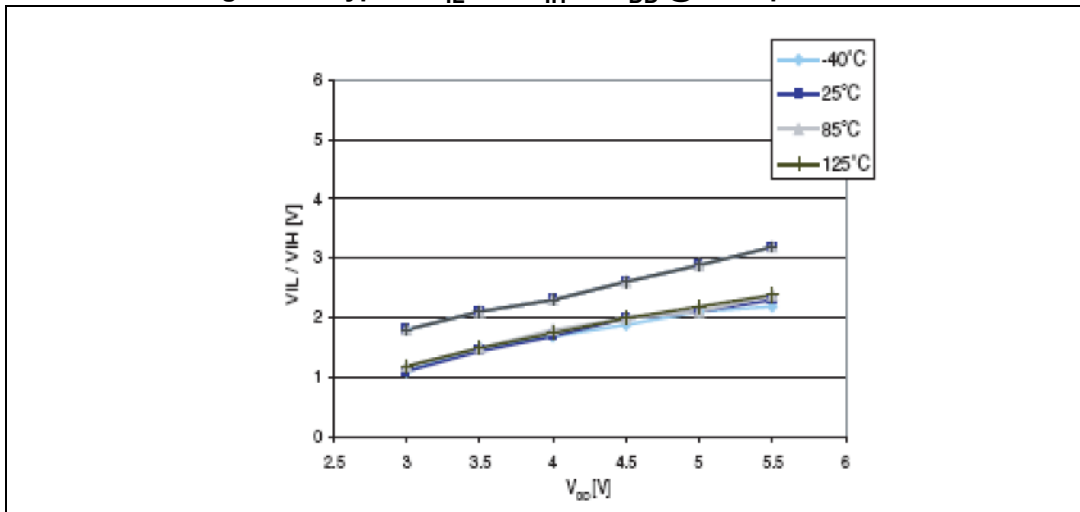

Figure 20. Typical pull-up resistance R_{PU} vs V_{DD} @ 4 temperatures

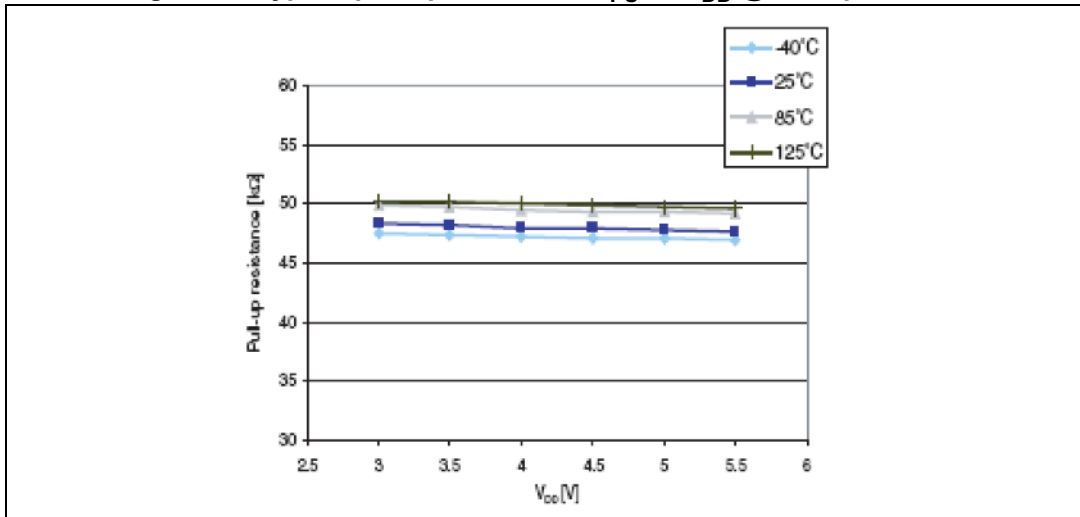

Figure 21. Typical pull-up current I_{pu} vs V_{DD} @ 4 temperatures

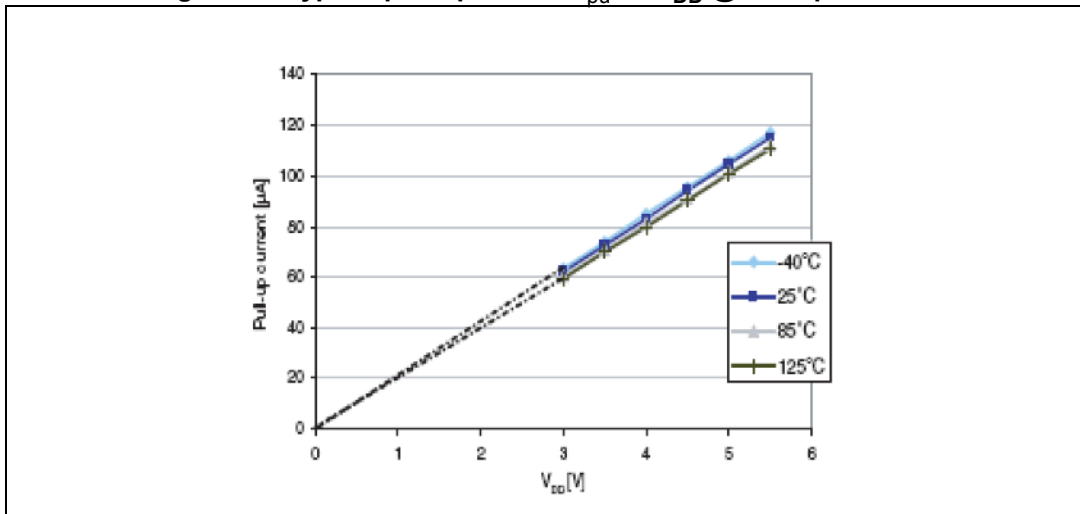

Table 49. Output driving current (standard ports)

Symbol	Parameter	Conditions	Min	Max	Unit
V_{OL}	Output low level with 8 pins sunk	$I_{IO} = 10\text{ mA}$, $V_{DD} = 5\text{ V}$	-	2.0	V
	Output low level with 4 pins sunk	$I_{IO} = 4\text{ mA}$, $V_{DD} = 3.3\text{ V}$	-	1.0 ⁽¹⁾	
V_{OH}	Output high level with 8 pins sourced	$I_{IO} = 10\text{ mA}$, $V_{DD} = 5\text{ V}$	2.8	-	
	Output high level with 4 pins sourced	$I_{IO} = 4\text{ mA}$, $V_{DD} = 3.3\text{ V}$	2.1 ⁽¹⁾	-	

1. Guaranteed by characterization results.

Table 50. Output driving current (true open drain ports)

Symbol	Parameter	Conditions	Max	Unit
V_{OL}	Output low level with 2 pins sunk	$I_{IO} = 10\text{ mA}$, $V_{DD} = 5\text{ V}$	1.0	V
		$I_{IO} = 10\text{ mA}$, $V_{DD} = 3.3\text{ V}$	1.5 ⁽¹⁾	
		$I_{IO} = 20\text{ mA}$, $V_{DD} = 5\text{ V}$	2.0 ⁽¹⁾	

1. Guaranteed by characterization results.

Table 51. Output driving current (high sink ports)

Symbol	Parameter	Conditions	Min	Max	Unit
V _{OL}	Output low level with 8 pins sunk	I _{IO} = 10 mA, V _{DD} = 5 V	-	0.8	V
	Output low level with 4 pins sunk	I _{IO} = 10 mA, V _{DD} = 3.3 V	-	1.0 ⁽¹⁾	
		I _{IO} = 20 mA, V _{DD} = 5 V		1.5 ⁽¹⁾	
V _{OH}	Output high level with 8 pins sourced	I _{IO} = 10 mA, V _{DD} = 5 V	4.0	-	
	Output high level with 4 pins sourced	I _{IO} = 10 mA, V _{DD} = 3.3 V	2.1 ⁽¹⁾	-	
		I _{IO} = 20 mA, V _{DD} = 5 V	3.3 ⁽¹⁾	-	

1. Guaranteed by characterization results.

Figure 22. Typ. V_{OL} @ V_{DD} = 5 V (standard ports)

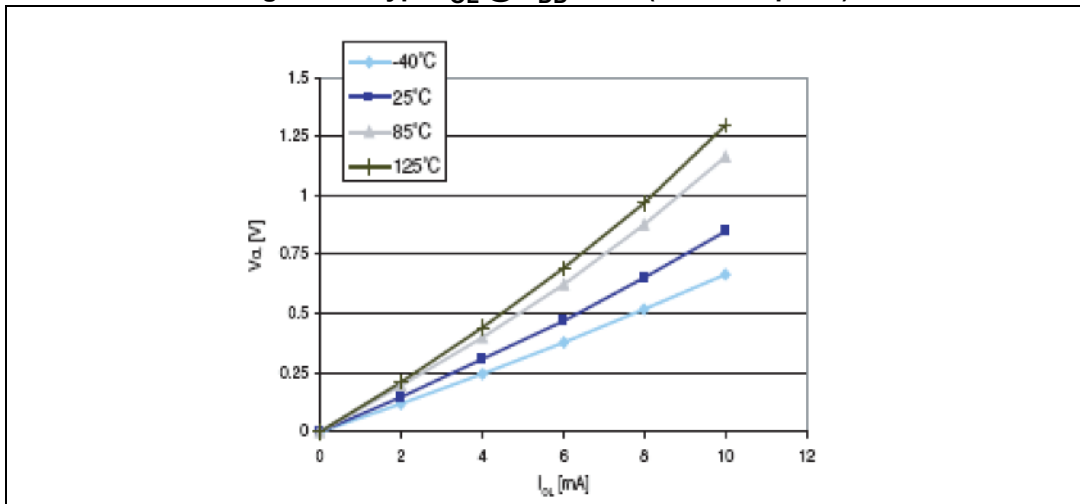

Figure 23. Typ. V_{OL} @ V_{DD} = 3.3 V (standard ports)

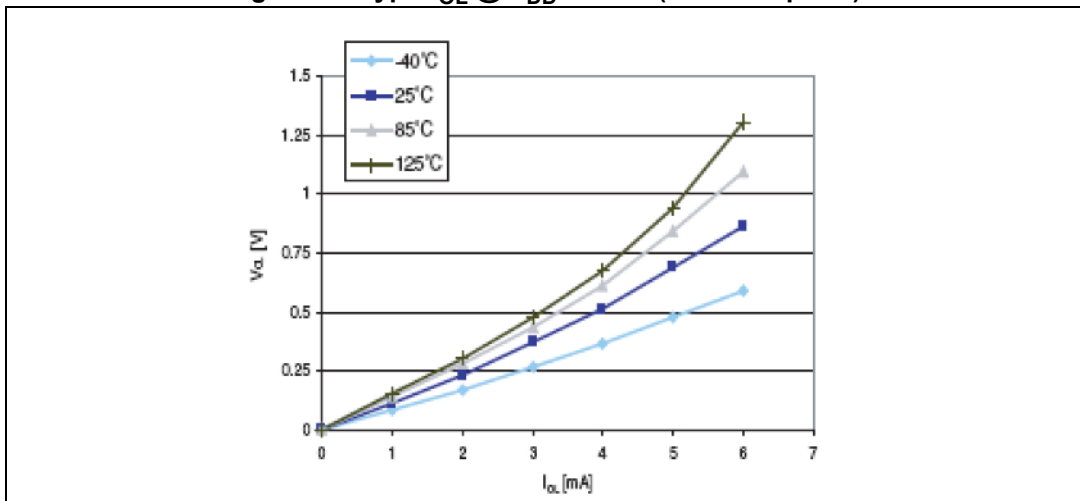

Figure 24. Typ. V_{OL} @ $V_{DD} = 5\text{ V}$ (true open drain ports)

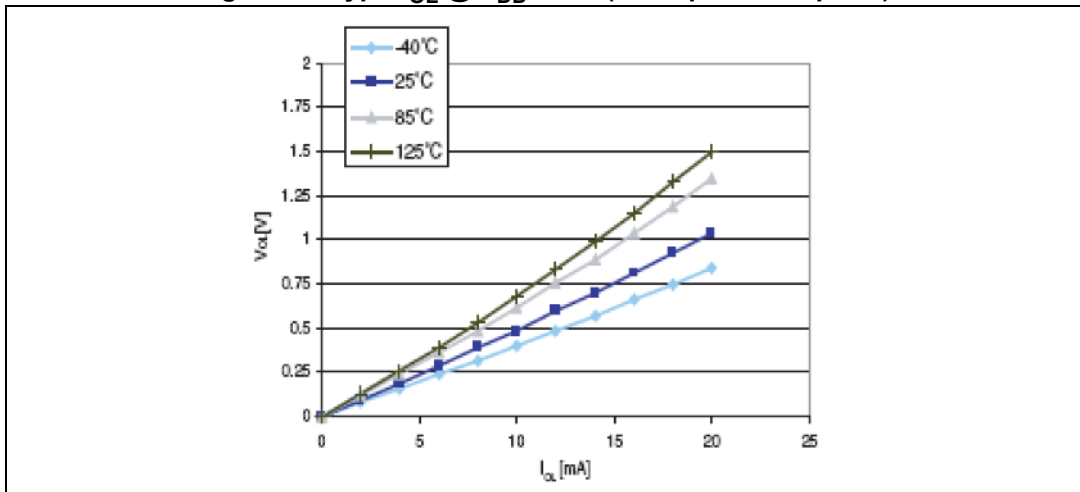

Figure 25. Typ. V_{OL} @ $V_{DD} = 3.3\text{ V}$ (true open drain ports)

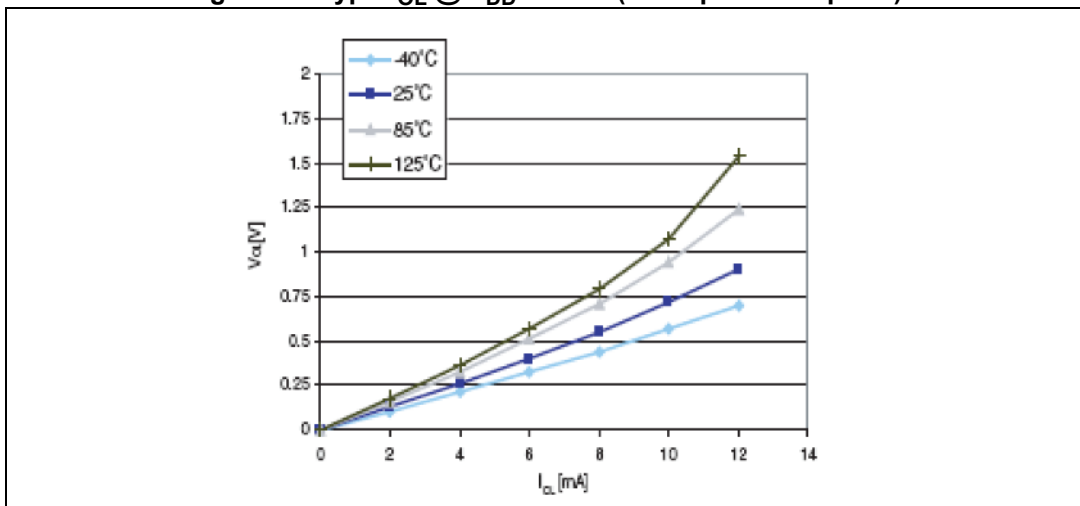

Figure 26. Typ. V_{OL} @ $V_{DD} = 5\text{ V}$ (high sink ports)

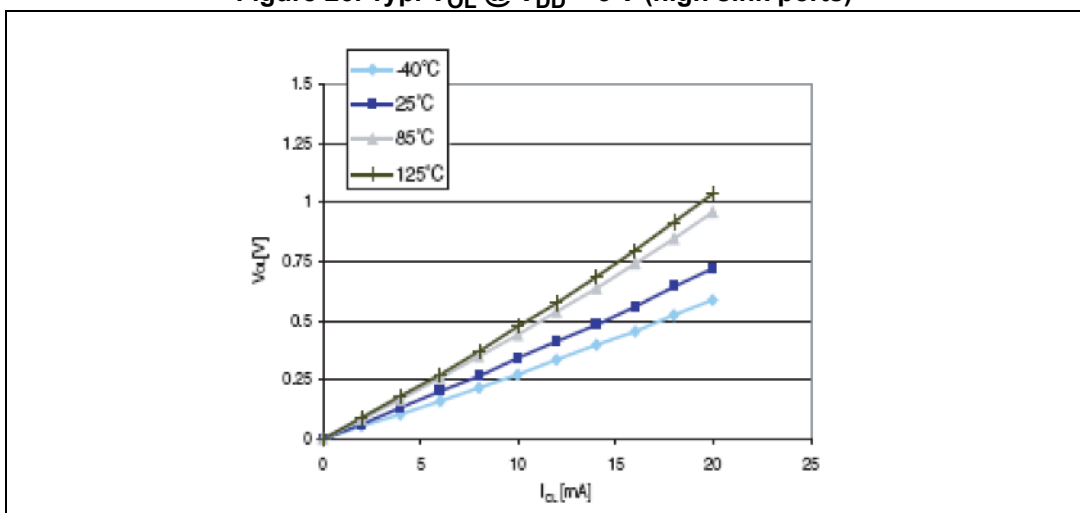

Figure 27. Typ. V_{OL} @ $V_{DD} = 3.3$ V (high sink ports)

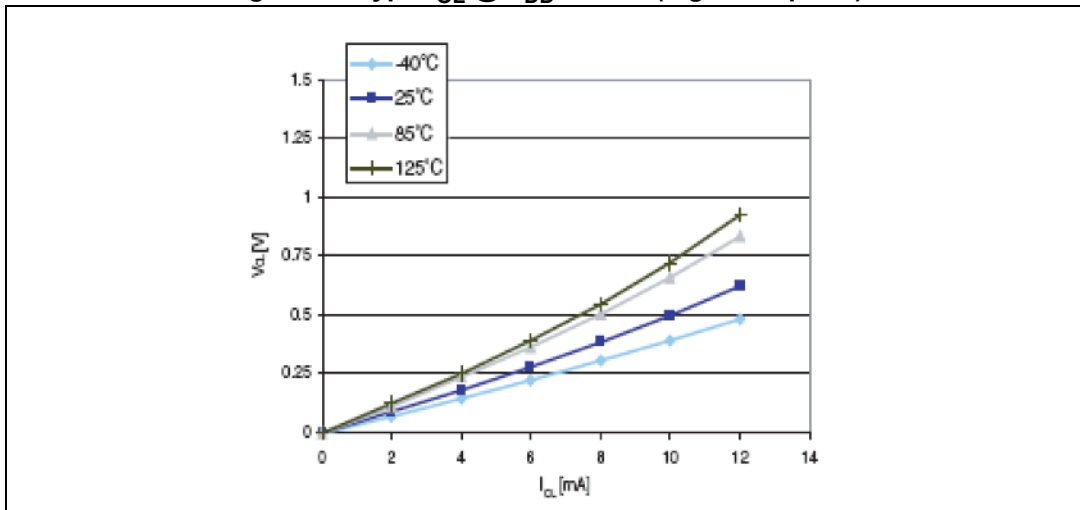

Figure 28. Typ. $V_{DD} - V_{OH}$ @ $V_{DD} = 5$ V (standard ports)

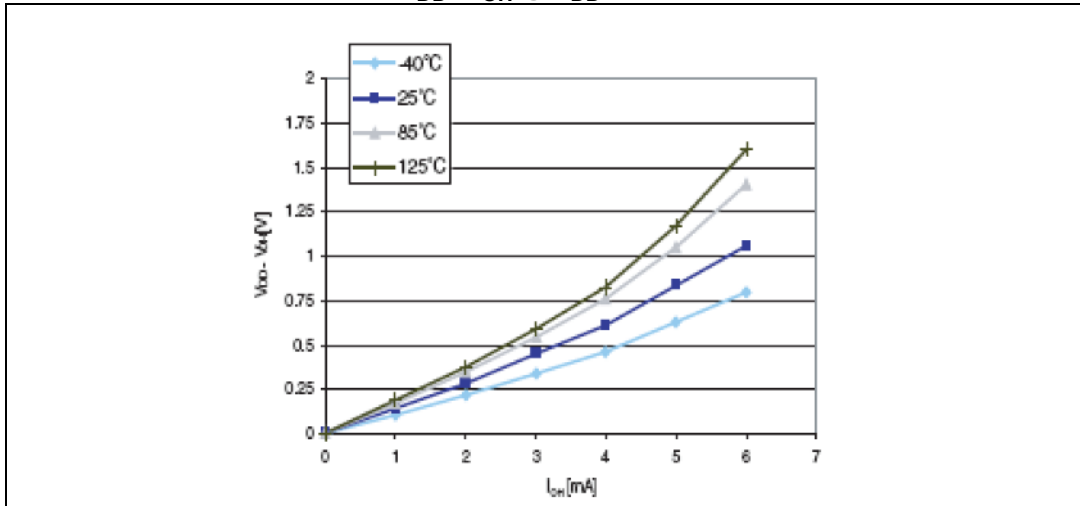

Figure 29. Typ. $V_{DD} - V_{OH}$ @ $V_{DD} = 3.3$ V (standard ports)

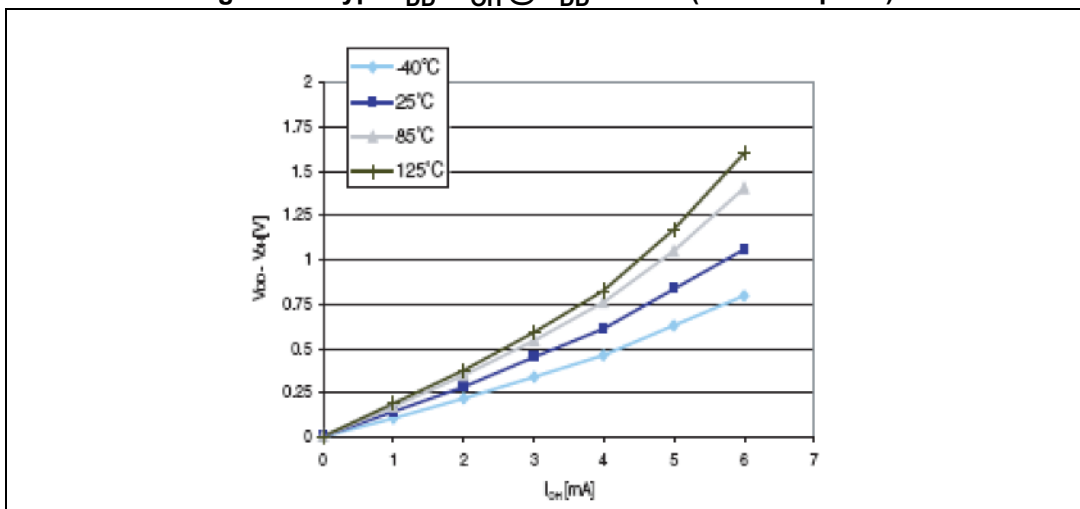

Figure 30. Typ. $V_{DD} - V_{OH}$ @ $V_{DD} = 5\text{ V}$ (high sink ports)

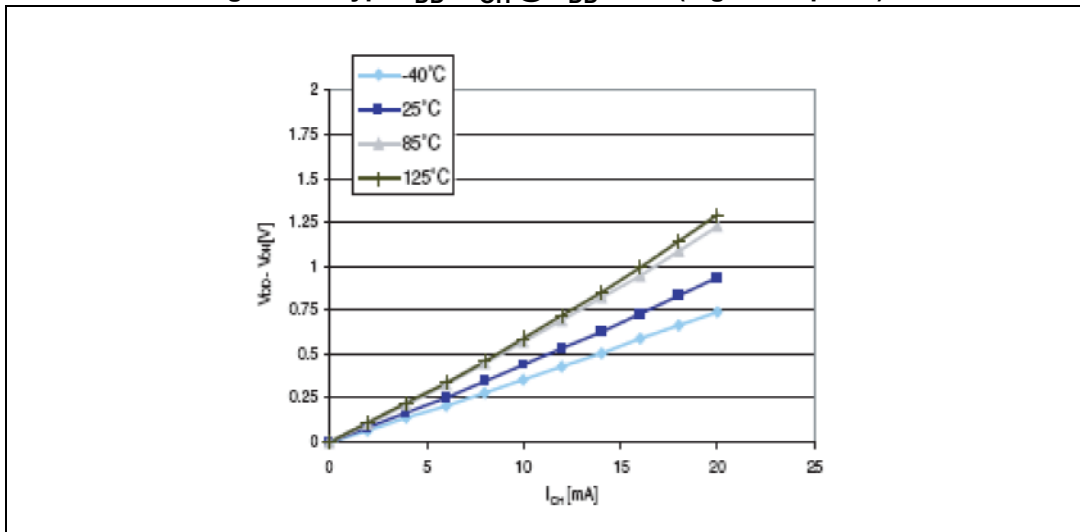
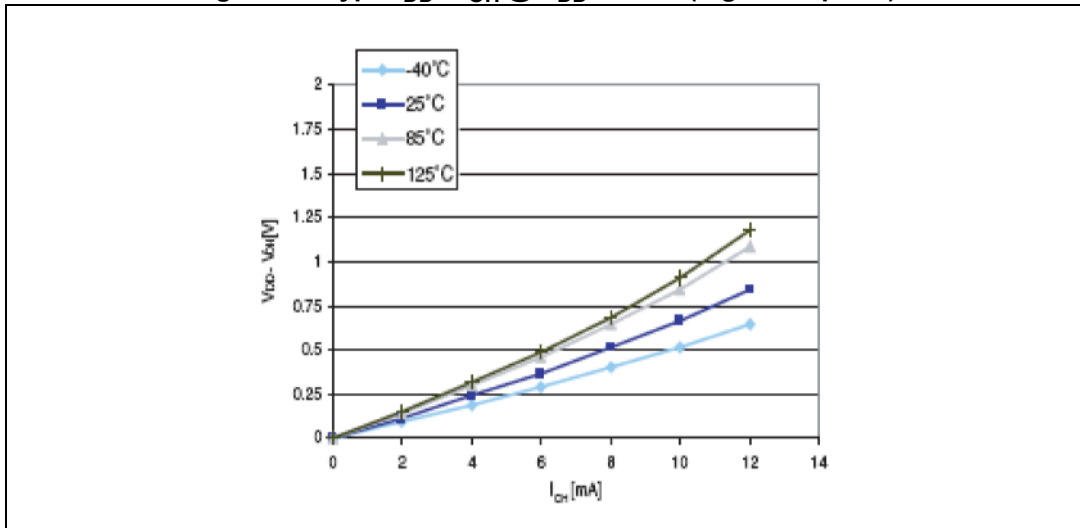

Figure 31. Typ. $V_{DD} - V_{OH}$ @ $V_{DD} = 3.3\text{ V}$ (high sink ports)



10.3.7 Reset pin characteristics

Subject to general operating conditions for V_{DD} and T_A unless otherwise specified.

Table 52. NRST pin characteristics

Symbol	Parameter	Conditions	Min	Typ	Max	Unit
$V_{IL(NRST)}$	NRST input low level voltage ⁽¹⁾	-	-0.3	-	$0.3 \times V_{DD}$	V
$V_{IH(NRST)}$	NRST input high level voltage ⁽¹⁾	$I_{OL} = 2 \text{ mA}$	$0.7 \times V_{DD}$	-	$V_{DD} + 0.3$	
$V_{OL(NRST)}$	NRST output low level voltage ⁽¹⁾	-	-	-	0.5	
$R_{PU(NRST)}$	NRST pull-up resistor ⁽²⁾	-	30	55	80	k Ω
$t_{IFP(NRST)}$	NRST input filtered pulse ⁽³⁾	-	-	-	75	ns
$t_{INFP(NRST)}$	NRST Input not filtered pulse duration ⁽³⁾	-	500	-	-	
$t_{OP(NRST)}$	NRST output pulse ⁽³⁾	-	20	-	-	

1. Guaranteed by characterization results.
2. The R_{PU} pull-up equivalent resistor is based on a resistive transistor.
3. Guaranteed by design.

Figure 32. Typical NRST V_{IL} and V_{IH} vs V_{DD} @ 4 temperatures

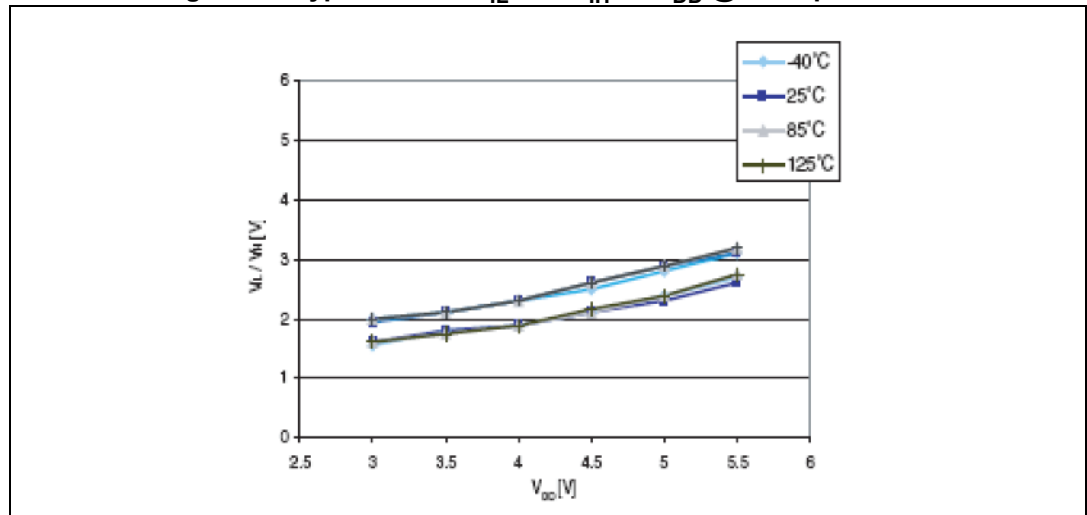

Figure 33. Typical NRST pull-up resistance vs V_{DD} @ 4 temperatures

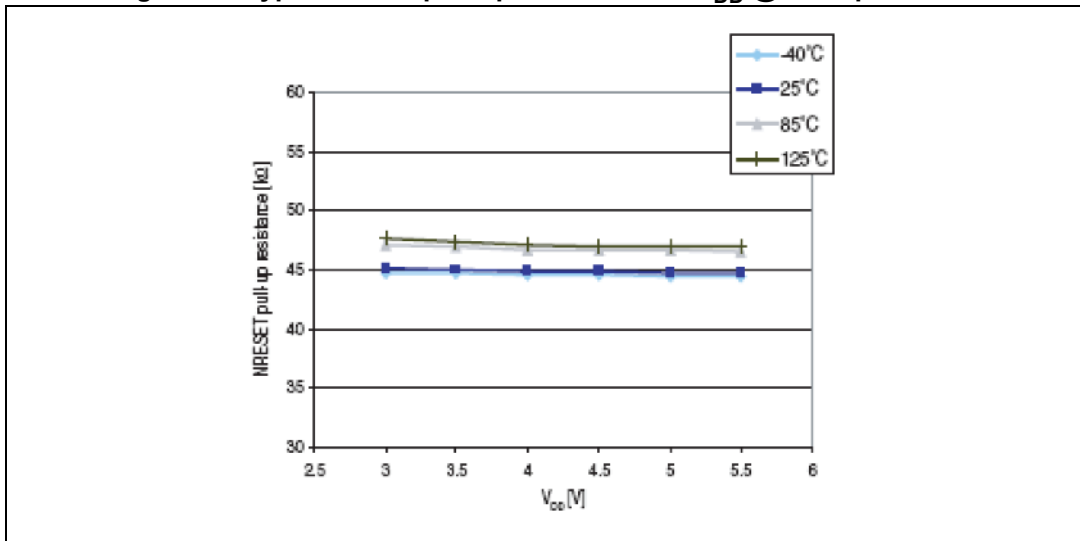
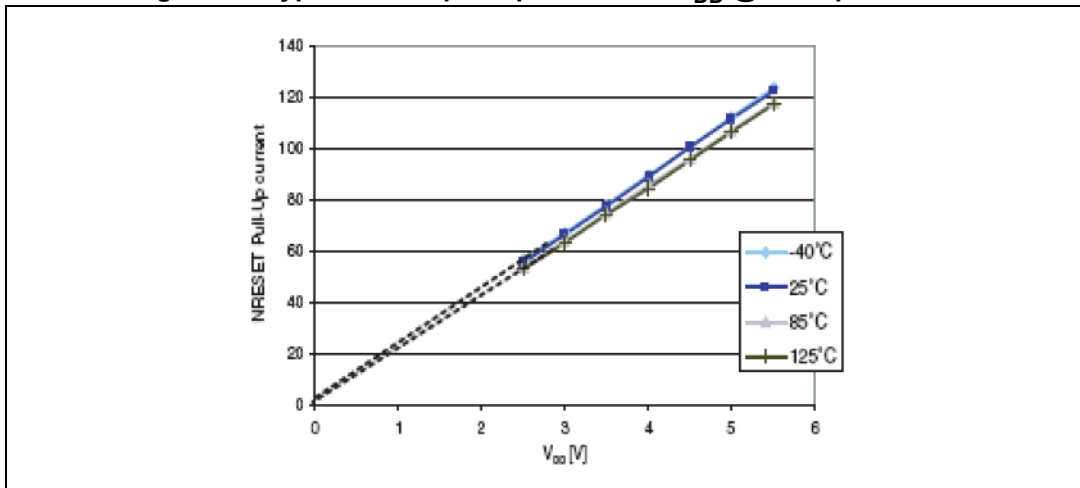

Figure 34. Typical NRST pull-up current vs V_{DD} @ 4 temperatures



The reset network shown in [Figure 35](#) protects the device against parasitic resets. The user must ensure that the level on the NRST pin can go below $V_{IL(NRST)}$ max (see [Table 52: NRST pin characteristics](#)), otherwise the reset is not taken into account internally.

For power consumption sensitive applications, the external reset capacitor value can be reduced to limit the charge/discharge current. If NRST signal is used to reset external circuitry, attention must be taken to the charge/discharge time of the external capacitor to fulfill the external devices reset timing conditions. Minimum recommended capacity is 100 nF.

Figure 35. Recommended reset pin protection

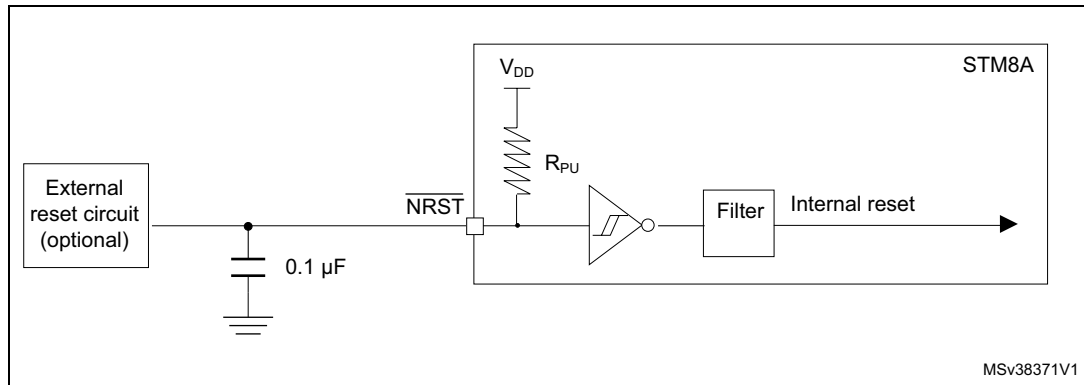

10.3.8 SPI serial peripheral interface

Unless otherwise specified, the parameters given in [Table 53](#) are derived from tests performed under ambient temperature, f_{MASTER} frequency and V_{DD} supply voltage conditions. $t_{MASTER} = 1/f_{MASTER}$.

Refer to I/O port characteristics for more details on the input/output alternate function characteristics (NSS, SCK, MOSI, MISO).

Table 53. SPI characteristics

Symbol	Parameter	Conditions ⁽¹⁾	Min	Max	Unit
f_{SCK} $1/t_{c(SCK)}$	SPI clock frequency	Master mode	0	8	MHz
		Slave mode	0	6	
$t_{r(SCK)}$ $t_{f(SCK)}$	SPI clock rise and fall time	Capacitive load: $C = 30 \text{ pF}$	-	25	ns
$t_{su(NSS)}^{(2)}$	NSS setup time	Slave mode	$4 * t_{MASTER}$	-	
$t_{h(NSS)}^{(2)}$	NSS hold time	Slave mode	70	-	
$t_{w(SCKH)}^{(2)}$ $t_{w(SCKL)}^{(2)}$	SCK high and low time	Master mode	$t_{SCK}/2 - 15$	$t_{SCK}/2 + 15$	
$t_{su(MI)}^{(2)}$ $t_{su(SI)}^{(2)}$	Data input setup time	Master mode	5	-	
		Slave mode	5	-	
$t_{h(MI)}^{(2)}$ $t_{h(SI)}^{(2)}$	Data input hold time	Master mode	7	-	
		Slave mode	10	-	
$t_{a(SO)}^{(2)(3)}$	Data output access time	Slave mode	-	$3 * t_{MASTER}$	
$t_{dis(SO)}^{(2)(4)}$	Data output disable time	Slave mode	25	-	
$t_{v(SO)}^{(2)}$	Data output valid time	Slave mode (after enable edge)	-	65	
$t_{v(MO)}^{(2)}$	Data output valid time	Master mode (after enable edge)	-	36	

Table 53. SPI characteristics (continued)

Symbol	Parameter	Conditions ⁽¹⁾	Min	Max	Unit
$t_{h(SO)}^{(2)}$	Data output hold time	Slave mode (after enable edge)	27	-	ns
$t_{h(MO)}^{(2)}$		Master mode (after enable edge)	11	-	

- Parameters are given by selecting 10 MHz I/O output frequency.
- Values based on design simulation and/or characterization results, and not tested in production.
- Min time is for the minimum time to drive the output and the max time is for the maximum time to validate the data.
- Min time is for the minimum time to invalidate the output and the max time is for the maximum time to put the data in Hi-Z.

Figure 36. SPI timing diagram - slave mode and CPHA = 0

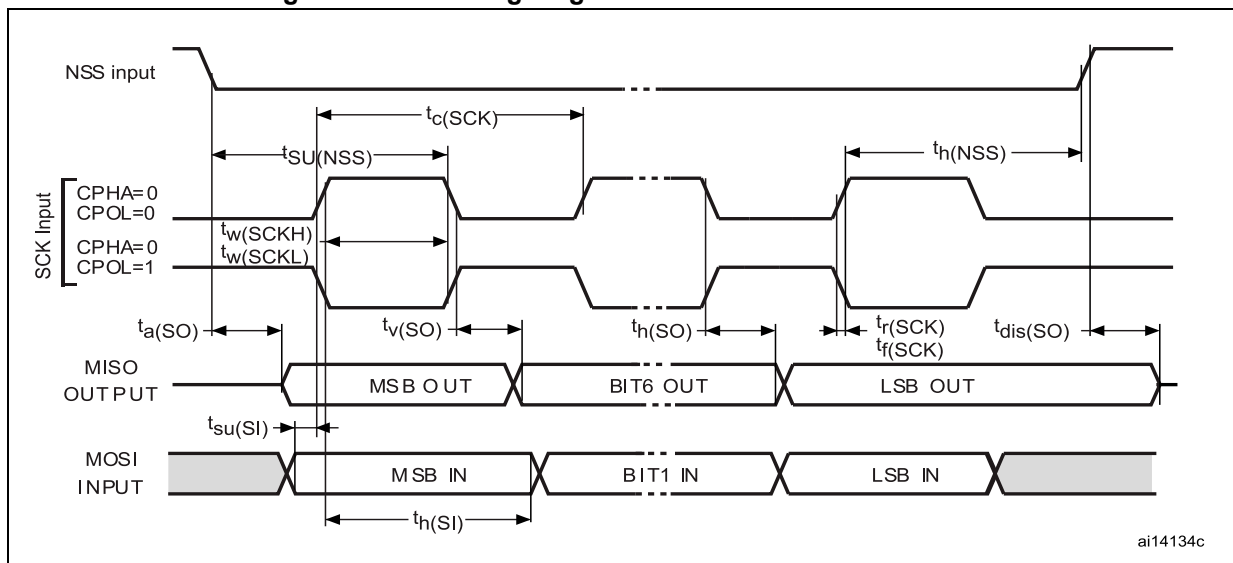

- Measurement points are made at CMOS levels: 0.3 V_{DD} and 0.7 V_{DD} .

Figure 37. SPI timing diagram - slave mode and CPHA = 1

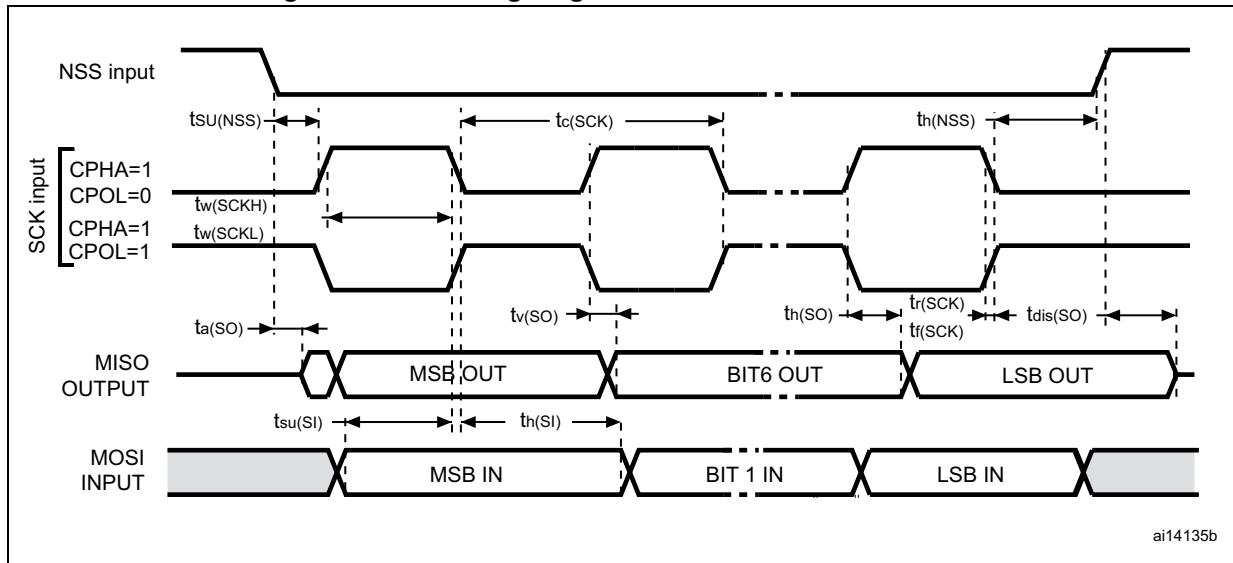

1. Measurement points are at CMOS levels: 0.3 V_{DD} and 0.7 V_{DD} .

Figure 38. SPI timing diagram - master mode⁽¹⁾

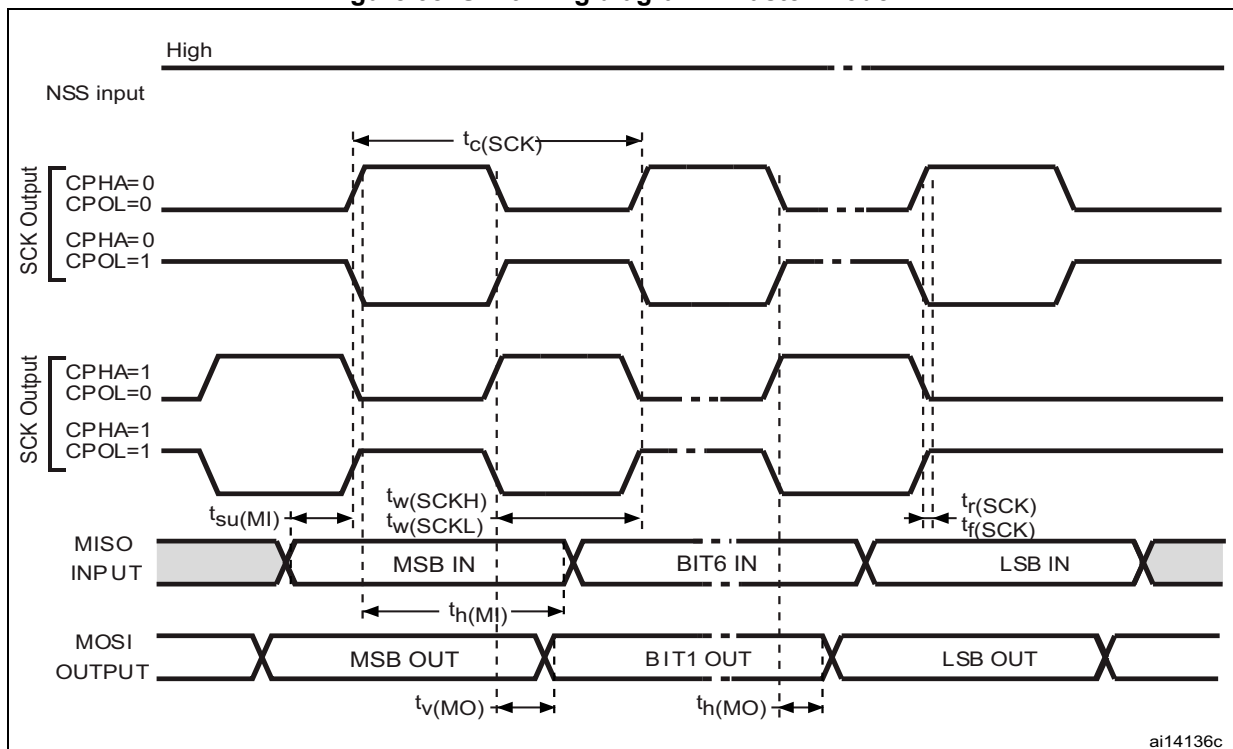

1. Measurement points are at CMOS levels: 0.3 V_{DD} and 0.7 V_{DD} .

10.3.9 I²C interface characteristicsTable 54. I²C characteristics

Symbol	Parameter	Standard mode I ² C		Fast mode I ² C ⁽¹⁾		Unit
		Min ⁽²⁾	Max ⁽²⁾	Min ⁽²⁾	Max ⁽²⁾	
t _{w(SCLL)}	SCL clock low time	4.7	-	1.3	-	μs
t _{w(SCLH)}	SCL clock high time	4.0	-	0.6	-	
t _{su(SDA)}	SDA setup time	250	-	100	-	ns
t _{h(SDA)}	SDA data hold time	0 ⁽³⁾	3450	0 ⁽⁴⁾	900 ⁽³⁾	
t _{r(SDA)} t _{r(SCL)}	SDA and SCL rise time	-	1000	-	300	
t _{f(SDA)} t _{f(SCL)}	SDA and SCL fall time	-	300	-	300	μs
t _{h(STA)}	START condition hold time	4.0	-	0.6	-	
t _{su(STA)}	Repeated START condition setup time	4.7	-	0.6	-	
t _{su(STO)}	STOP condition setup time	4.0	-	0.6	-	
t _{w(STO:STA)}	STOP to START condition time (bus free)	4.7	-	1.3	-	ns
t _{SP}	Pulse width of spikes suppressed by the input filter	0	50 ⁽⁵⁾	0	50	
C _b	Capacitive load for each bus line	-	400	-	400	pF

1. f_{MASTER} must be at least 8 MHz to achieve max fast I²C speed (400 kHz)
2. Data based on standard I²C protocol requirement, not tested in production
3. The maximum hold time of the start condition has only to be met if the interface does not stretch the low time
4. The device must internally provide a hold time of at least 300 ns for the SDA signal in order to bridge the undefined region of the falling edge of SCL
5. The minimum width of the spikes filtered by the analog filter is above t_{SP(max)}

Figure 39. Typical application with I2C bus and timing diagram



1. Measurement points are made at CMOS levels: $0.3 \times V_{DD}$ and $0.7 \times V_{DD}$.

10.3.10 10-bit ADC characteristics

Subject to general operating conditions for V_{DD} , f_{MASTER} , and T_A unless otherwise specified.

Table 55. ADC characteristics

Symbol	Parameter	Conditions	Min	Typ	Max	Unit
f_{ADC}	ADC clock frequency	$V_{DD} = 3$ to 5.5 V	1	-	4	MHz
		$V_{DD} = 4.5$ to 5.5 V	1	-	6	
V_{AIN}	Conversion voltage range ⁽¹⁾	-	V_{SS}	-	V_{DD}	V
V_{BGMREF}	Internal bandgap reference voltage	$V_{DD} = 3$ to 5.5 V	1.19 ⁽²⁾	1.22	1.25 ⁽²⁾	V
C_{ADC}	Internal sample and hold capacitor	-	-	3	-	pF
$t_S^{(1)}$	Minimum sampling time	$f_{ADC} = 4$ MHz	-	0.75	-	μ s
		$f_{ADC} = 6$ MHz	-	0.5	-	
t_{STAB}	Wakeup time from standby	-	-	7	-	
t_{CONV}	Minimum total conversion time including sampling time, 10-bit resolution	$f_{ADC} = 4$ Hz	3.5			μ s
		$f_{ADC} = 6$ MHz	2.33			
		-	14			$1/f_{ADC}$

1. During the sample time the input capacitance C_{AIN} (3 pF max) can be charged/discharged by the external source. The internal resistance of the analog source must allow the capacitance to reach its final voltage level within t_S . After the end of the sample time t_S , changes of the analog input voltage have no effect on the conversion result. Values for the sample clock t_S depend on programming.

2. Tested in production.

Table 56. ADC accuracy with RAIN < 10 kΩ, V_{DD} = 5 V

Symbol	Parameter	Conditions	Typ	Max ⁽¹⁾	Unit
E _T	Total unadjusted error ⁽²⁾	f _{ADC} = 2 MHz	1.6	3.5	LSB
		f _{ADC} = 4 MHz	2.2	4	
		f _{ADC} = 6 MHz	2.4	4.5	
E _O	Offset error ⁽²⁾	f _{ADC} = 2 MHz	1.1	2.5	
		f _{ADC} = 4 MHz	1.5	3	
		f _{ADC} = 6 MHz	1.8	3	
E _G	Gain error ⁽²⁾	f _{ADC} = 2 MHz	1.5	3	
		f _{ADC} = 4 MHz	2.1	3	
		f _{ADC} = 6 MHz	2.2	4	
E _D	Differential linearity error ⁽²⁾	f _{ADC} = 2 MHz	0.7	1.5	
		f _{ADC} = 4 MHz	0.7	1.5	
		f _{ADC} = 6 MHz	0.7	1.5	
E _L	Integral linearity error ⁽²⁾	f _{ADC} = 2 MHz	0.6	1.5	
		f _{ADC} = 4 MHz	0.8	2	
		f _{ADC} = 6 MHz	0.8	2	

1. Max value is guaranteed by characterization results.
2. ADC accuracy vs. negative injection current: Injecting negative current on any of the analog input pins should be avoided as this significantly reduces the accuracy of the conversion being performed on another analog input. It is recommended to add a Schottky diode (pin to ground) to standard analog pins which may potentially inject negative current. Any positive injection current within the limits specified for I_{INJ(PIN)} and ΣI_{INJ(PIN)} in the I/O port pin characteristics section does not affect the ADC accuracy.

Table 57. ADC accuracy with RAIN < 10 kΩ, V_{DD} = 3.3 V

Symbol	Parameter	Conditions	Typ	Max ⁽¹⁾	Unit
E _T	Total unadjusted error	f _{ADC} = 2 MHz	1.6	3.5	LSB
		f _{ADC} = 4 MHz	1.9	4	
E _O	Offset error	f _{ADC} = 2 MHz	1	2.5	
		f _{ADC} = 4 MHz	1.5	2.5	
E _G	Gain error	f _{ADC} = 2 MHz	1.3	3	
		f _{ADC} = 4 MHz	2	3	
E _D	Differential linearity error	f _{ADC} = 2 MHz	0.7	1	
		f _{ADC} = 4 MHz	0.7	1.5	
E _L	Integral linearity error	f _{ADC} = 2 MHz	0.6	1.5	
		f _{ADC} = 4 MHz	0.8	2	

1. Max value is guaranteed by characterization results.

Figure 40. ADC accuracy characteristics

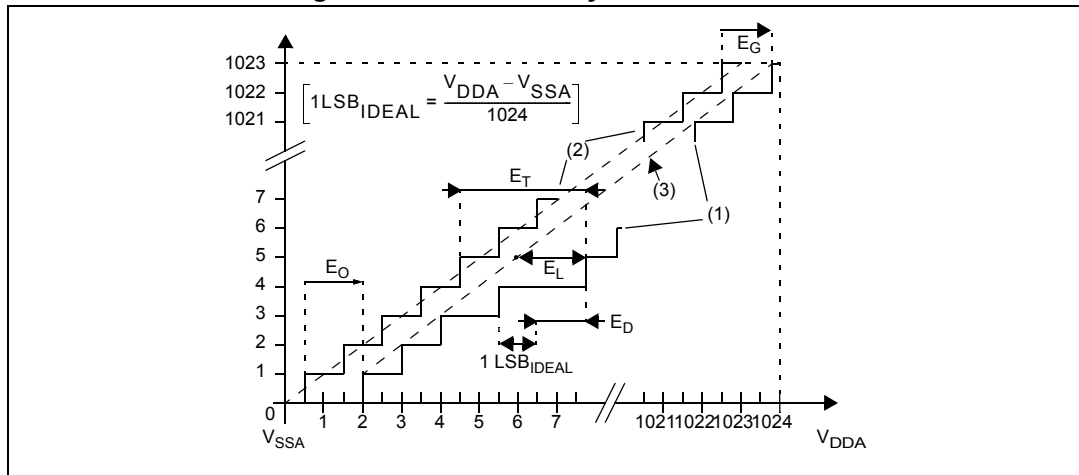

1. Example of an actual transfer curve
 2. The ideal transfer curve
 3. End point correlation line
- E_T** = Total unadjusted error: Maximum deviation between the actual and the ideal transfer curves.
E_O = Offset error: Deviation between the first actual transition and the first ideal one.
E_G = Gain error: Deviation between the last ideal transition and the last actual one.
E_D = Differential linearity error: Maximum deviation between actual steps and the ideal one.
E_L = Integral linearity error: Maximum deviation between any actual transition and the end point correlation line.

Figure 41. Typical application with ADC

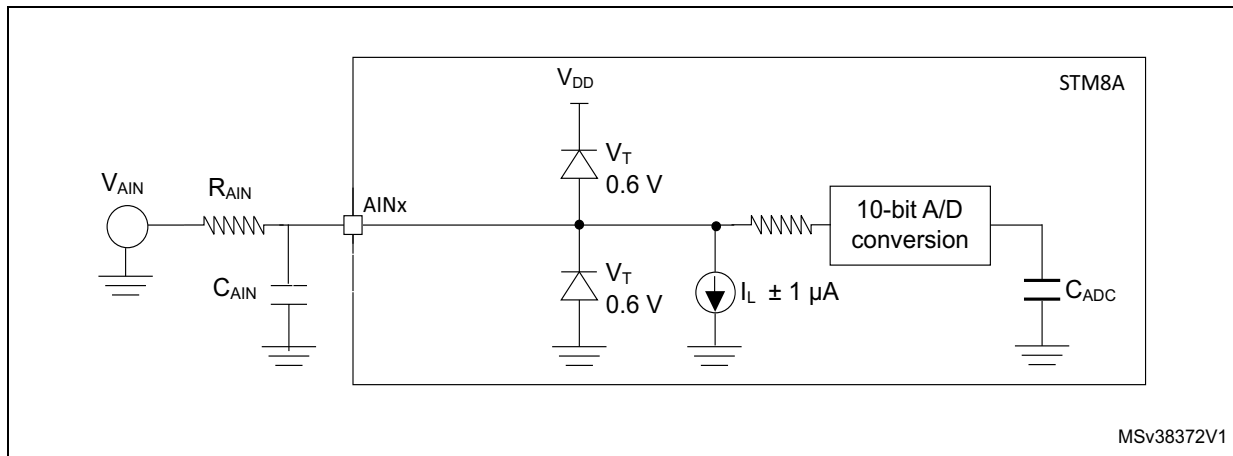

1. Legend: R_{AIN} = external resistance, C_{AIN} = capacitors, C_{samp} = internal sample and hold capacitor.

10.3.11 EMC characteristics

Susceptibility tests are performed on a sample basis during product characterization.

Functional EMS (electromagnetic susceptibility)

While executing a simple application (toggling 2 LEDs through I/O ports), the product is stressed by two electromagnetic events until a failure occurs (indicated by the LEDs).

- **FESD:** Functional electrostatic discharge (positive and negative) is applied on all pins of the device until a functional disturbance occurs. This test conforms with the IEC 61000-4-2 standard.
- **FTB:** A burst of fast transient voltage (positive and negative) is applied to V_{DD} and V_{SS} through a 100 pF capacitor, until a functional disturbance occurs. This test conforms with the IEC 61000-4-4 standard.

A device reset allows normal operations to be resumed. The test results are given in the table below based on the EMS levels and classes defined in application note AN1709.

Designing hardened software to avoid noise problems

EMC characterization and optimization are performed at component level with a typical application environment and simplified MCU software. It should be noted that good EMC performance is highly dependent on the user application and the software in particular.

Therefore it is recommended that the user applies EMC software optimization and prequalification tests in relation with the EMC level requested for his application.

Prequalification trials

Most of the common failures (unexpected reset and program counter corruption) can be recovered by applying a low state on the NRST pin or the oscillator pins for 1 second.

To complete these trials, ESD stress can be applied directly on the device, over the range of specification values. When unexpected behavior is detected, the software can be hardened to prevent unrecoverable errors occurring (see the application note reference AN1015).

Table 58. EMS data

Symbol	Parameter	Conditions	Level/class
V_{FESD}	Voltage limits to be applied on any I/O pin to induce a functional disturbance	$V_{DD} = 3.3\text{ V}$, $T_A = 25\text{ }^\circ\text{C}$, $f_{MASTER} = 16\text{ MHz}$ (HSI clock), Conforms to IEC 61000-4-2	2/B ⁽¹⁾
V_{EFTB}	Fast transient voltage burst limits to be applied through 100 pF on V_{DD} and V_{SS} pins to induce a functional disturbance	$V_{DD} = 3.3\text{ V}$, $T_A = 25\text{ }^\circ\text{C}$, $f_{MASTER} = 16\text{ MHz}$ (HSI clock), Conforms to IEC 61000-4-4	4/A

1. Data obtained with HSI clock configuration, after applying hardware recommendations described in AN2860 (EMC guidelines for STM8S microcontrollers).

Electromagnetic interference (EMI)

Based on a simple application running on the product (toggling 2 LEDs through the I/O ports), the product is monitored in terms of emission. This emission test is in line with the norm IEC 61967-2 which specifies the board and the loading of each pin.

Table 59. EMI data

Symbol	Parameter	Conditions				Unit
		General conditions	Monitored frequency band	Max $f_{HSE}/f_{CPU}^{(1)}$		
				16 MHz/8 MHz	16 MHz/16 MHz	
S _{EMI}	Peak level	V _{DD} = 5 V, T _A = 25 °C, LQFP32 package conforming to IEC 61967-2	0.1 MHz to 30 MHz	5	5	dB μ V
			30 MHz to 130 MHz	4	5	
			130 MHz to 1 GHz	5	5	
	EMI level	—	2.5	2.5	level	

1. Guaranteed by characterization results.

Absolute maximum ratings (electrical sensitivity)

Based on three different tests (ESD, DLU and LU) using specific measurement methods, the product is stressed to determine its performance in terms of electrical sensitivity. For more details, refer to the application note AN1181.

Electrostatic discharge (ESD)

Electrostatic discharges (one positive then one negative pulses separated by 1 second) are applied to the pins of each sample according to each pin combination. The sample size depends on the number of supply pins in the device (3 parts*(n+1) supply pin). One model can be simulated: Human body model. This test conforms to the JESD22-A114A/A115A standard. For more details, refer to the application note AN1181.

Table 60. ESD absolute maximum ratings

Symbol	Ratings	Conditions	Class	Maximum value ⁽¹⁾	Unit
V _{ESD(HBM)}	Electrostatic discharge voltage (Human body model)	T _A = 25°C, conforming to JESD22-A114	3A	4000	V
V _{ESD(CDM)}	Electrostatic discharge voltage (Charge device model)	T _A = 25°C, conforming to JESD22-C101	3	500	
V _{ESD(MM)}	Electrostatic discharge voltage (Machine model)	T _A = 25°C, conforming to JESD22-A115	B	200	

1. Guaranteed by characterization results.

Static latch-up

Two complementary static tests are required on six parts to assess the latch-up performance:

- A supply overvoltage (applied to each power supply pin),
- A current injection (applied to each input, output and configurable I/O pin) are performed on each sample.

This test conforms to the EIA/JESD 78 IC latch-up standard. For more details, refer to the application note AN1181.

Table 61. Electrical sensitivities

Symbol	Parameter	Conditions	Class ⁽¹⁾
LU	Static latch-up class	T _A = 25 °C	A
		T _A = 85 °C	
		T _A = 125 °C	
		T _A = 150 °C	

1. Class description: A Class is an STMicroelectronics internal specification. All its limits are higher than the JEDEC specifications, that means when a device belongs to class A it exceeds the JEDEC standard. B class strictly covers all the JEDEC criteria (international standard).

11 Package information

In order to meet environmental requirements, ST offers these devices in different grades of ECOPACK packages, depending on their level of environmental compliance. ECOPACK specifications, grade definitions and product status are available at: www.st.com. ECOPACK is an ST trademark.

11.1 TSSOP20 package information

Figure 42. TSSOP20 – 20-lead thin shrink small outline, 6.5 x 4.4 mm, 0.65 mm pitch, package outline

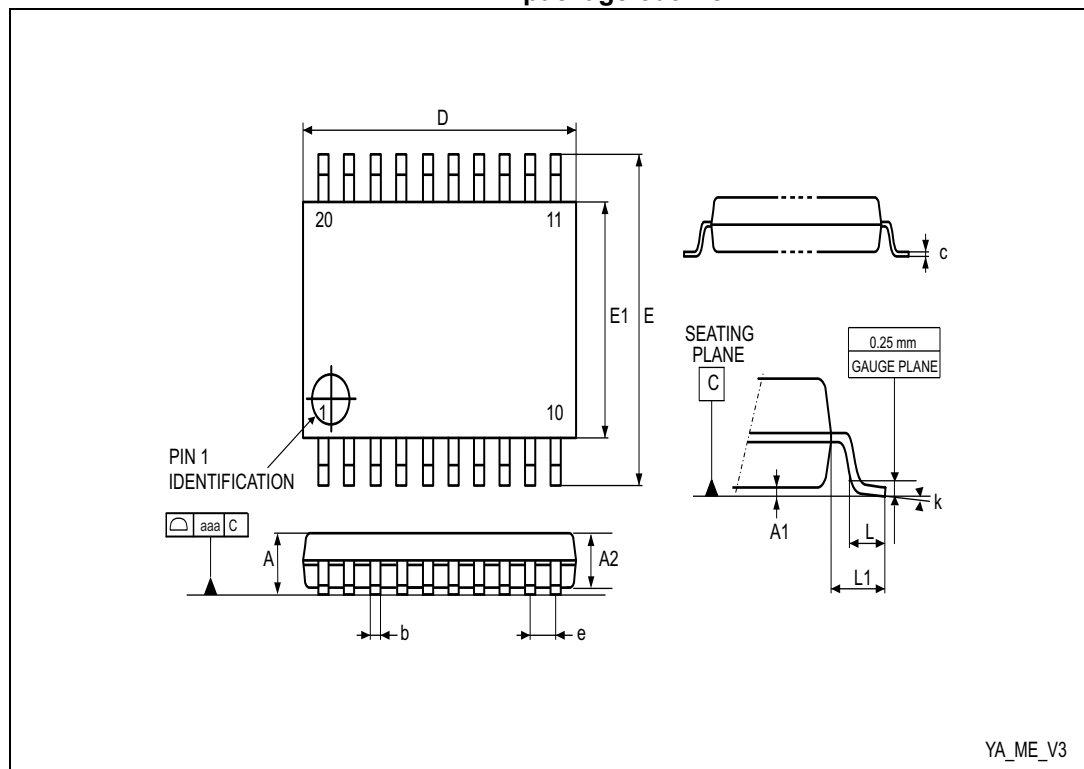

1. Drawing is not to scale.

Table 62. TSSOP20 – 20-lead thin shrink small outline, 6.5 x 4.4 mm, 0.65 mm pitch, package mechanical data

Symbol	millimeters			inches ⁽¹⁾		
	Min.	Typ.	Max.	Min.	Typ.	Max.
A	-	-	1.200	-	-	0.0472
A1	0.050	-	0.150	0.0020	-	0.0059
A2	0.800	1.000	1.050	0.0315	0.0394	0.0413
b	0.190	-	0.300	0.0075	-	0.0118
c	0.090	-	0.200	0.0035	-	0.0079
D ⁽²⁾	6.400	6.500	6.600	0.2520	0.2559	0.2598
E	6.200	6.400	6.600	0.2441	0.2520	0.2598
E1 ⁽³⁾	4.300	4.400	4.500	0.1693	0.1732	0.1772
e	-	0.650	-	-	0.0256	-
L	0.450	0.600	0.750	0.0177	0.0236	0.0295
L1	-	1.000	-	-	0.0394	-
k	0°	-	8°	0°	-	8°
aaa	-	-	0.100	-	-	0.0039

1. Values in inches are converted from mm and rounded to four decimal digits.
2. Dimension "D" does not include mold flash, protrusions or gate burrs. Mold flash, protrusions or gate burrs shall not exceed 0.15mm per side.
3. Dimension "E1" does not include interlead flash or protrusions. Interlead flash or protrusions shall not exceed 0.25mm per side.

Figure 43. TSSOP20 – 20-lead thin shrink small outline, 6.5 x 4.4 mm, 0.65 mm pitch, package footprint

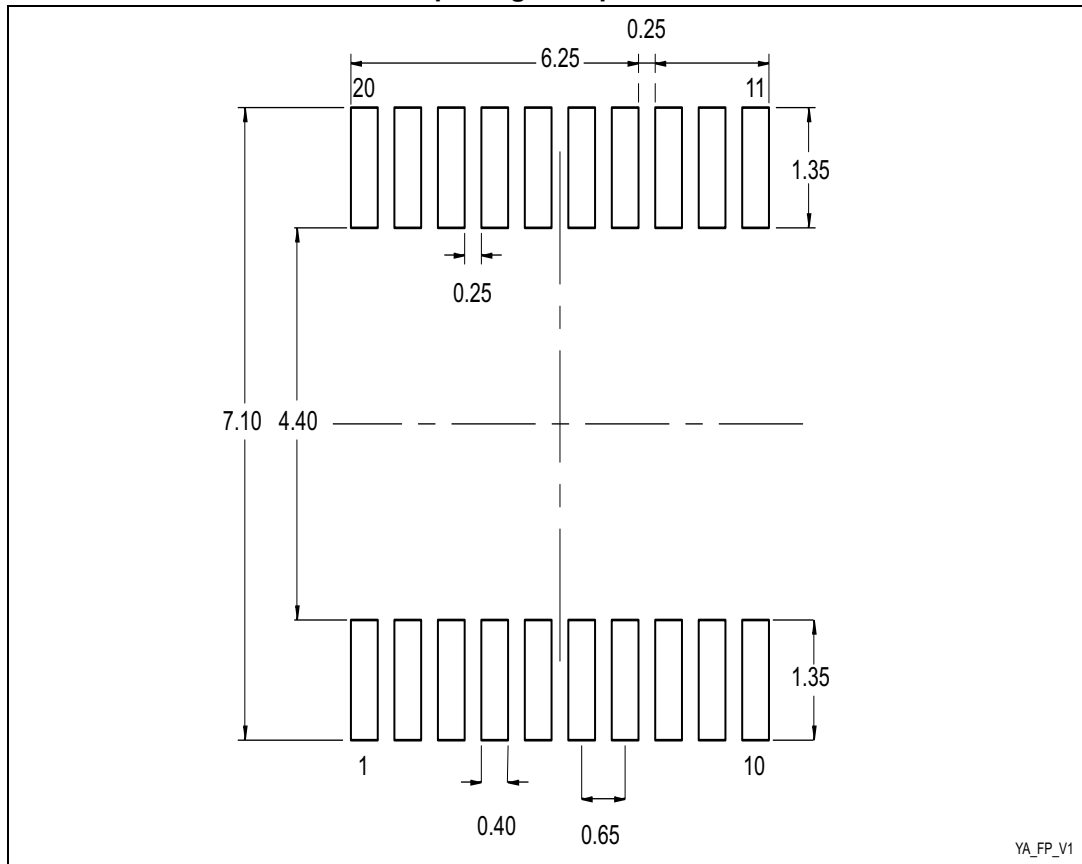

YA_FP_V1

1. Dimensions are expressed in millimeters.

Device marking for TSSOP20

The following figure gives an example of topside marking orientation versus pin 1 identifier location.

Other optional marking or inset/upset marks, which depend on supply chain operations, are not indicated below.

Figure 44. TSSOP20 marking example (package top view)

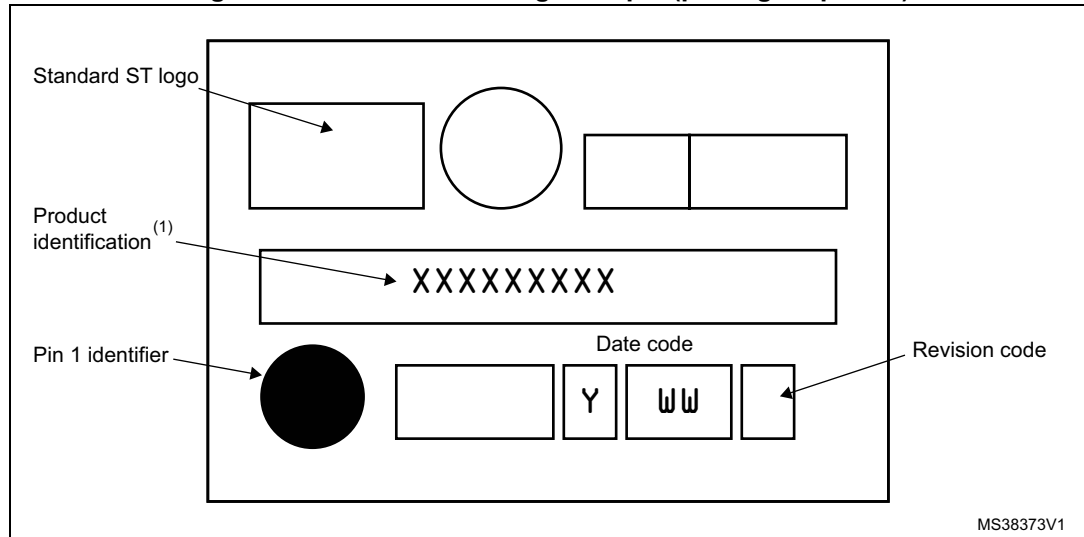

1. Parts marked as "ES" or "E" are not yet qualified and therefore not approved for use in production. ST is not responsible for any consequences resulting from such use. In no event will ST be liable for the customer using any of these engineering samples in production. ST's Quality department must be contacted prior to any decision to use these engineering samples to run a qualification activity.

11.2 LQFP32 package information

Figure 45. LQFP32 - 32-pin, 7 x 7 mm low-profile quad flat package outline

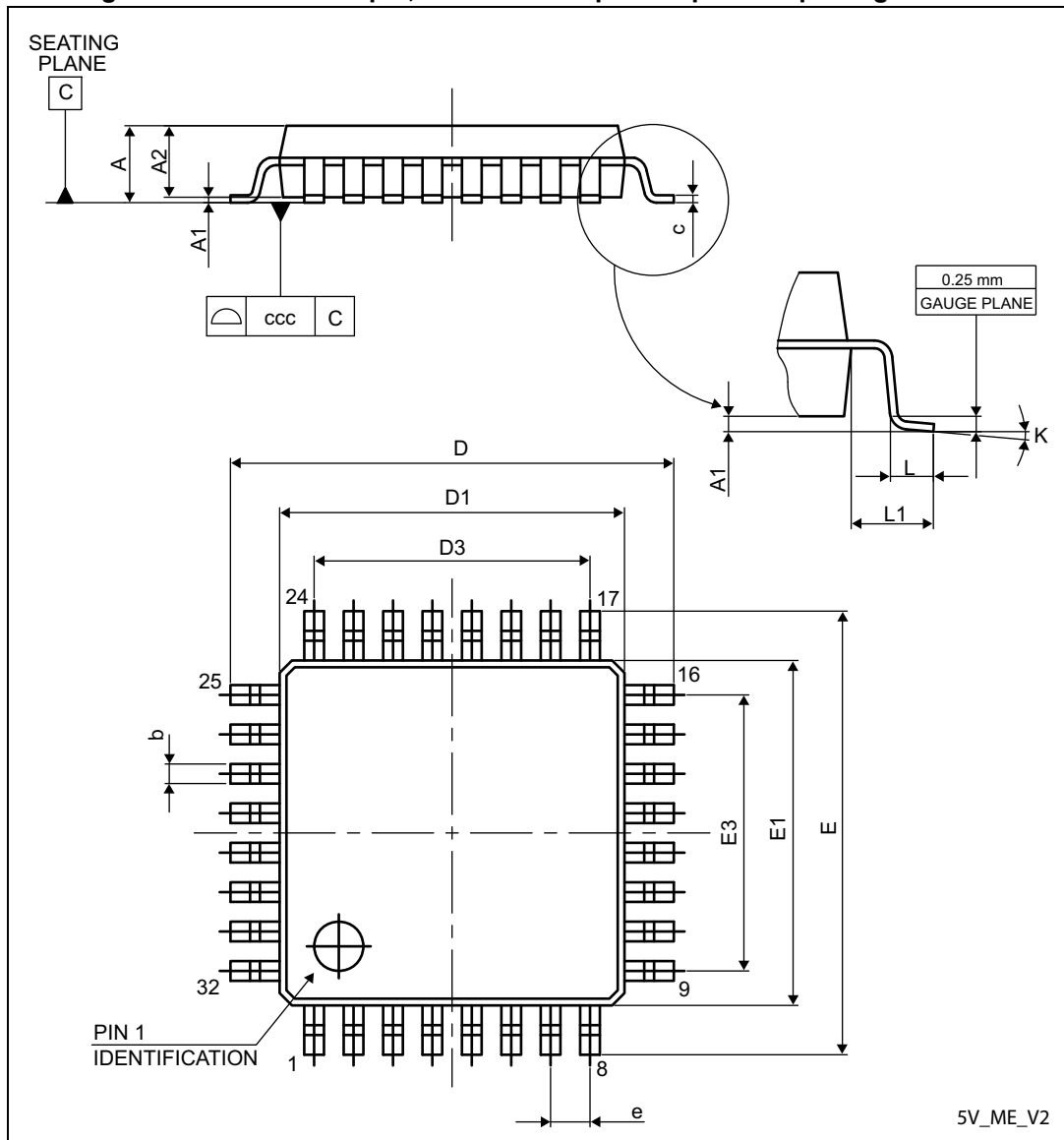

5V_ME_V2

1. Drawing is not to scale.

**Table 63. LQFP32 - 32-pin, 7 x 7 mm low-profile quad flat package
mechanical data**

Symbol	millimeters			inches ⁽¹⁾		
	Min	Typ	Max	Min	Typ	Max
A	-	-	1.600	-	-	0.0630
A1	0.050	-	0.150	0.0020	-	0.0059
A2	1.350	1.400	1.450	0.0531	0.0551	0.0571
b	0.300	0.370	0.450	0.0118	0.0146	0.0177
c	0.090	-	0.200	0.0035	-	0.0079
D	8.800	9.000	9.200	0.3465	0.3543	0.3622
D1	6.800	7.000	7.200	0.2677	0.2756	0.2835
D3	-	5.600	-	-	0.2205	-
E	8.800	9.000	9.200	0.3465	0.3543	0.3622
E1	6.800	7.000	7.200	0.2677	0.2756	0.2835
E3	-	5.600	-	-	0.2205	-
e	-	0.800	-	-	0.0315	-
L	0.450	0.600	0.750	0.0177	0.0236	0.0295
L1	-	1.000	-	-	0.0394	-
k	0°	3.5°	7°	0°	3.5°	7°
ccc	-	-	0.100	-	-	0.0039

1. Values in inches are converted from mm and rounded to 4 decimal digits.

Figure 46. LQFP32 - 32-pin, 7 x 7 mm low-profile quad flat package recommended footprint

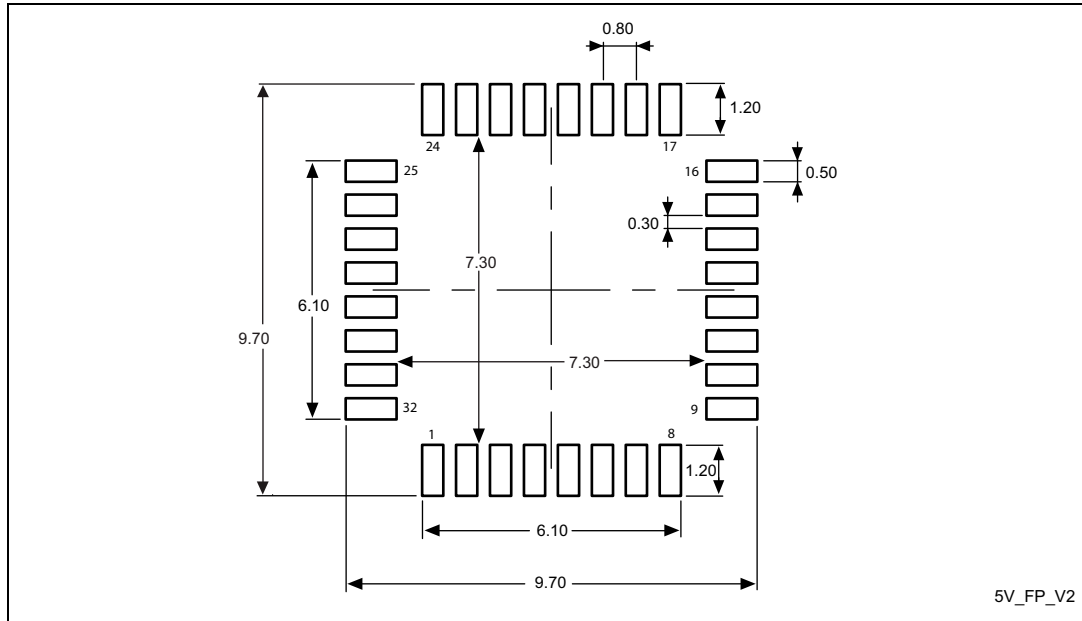

1. Dimensions are expressed in millimeters.

Device marking for LQFP32

The following figure gives an example of topside marking orientation versus pin 1 identifier location. Other optional marking or inset/upset marks, which depend on supply chain operations, are not indicated below.

Figure 47. LQFP32 marking example (package top view)

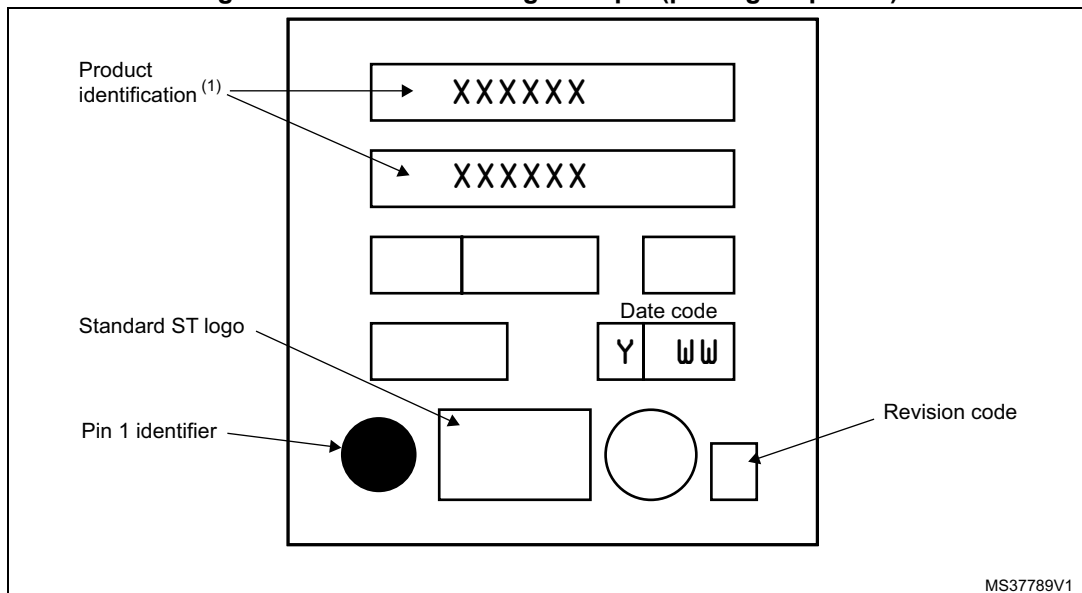

1. Parts marked as “ES” or “E” are not yet qualified and therefore not approved for use in production. ST is not responsible for any consequences resulting from such use. In no event will ST be liable for the customer using any of these engineering samples in production. ST’s Quality department must be contacted prior to any decision to use these engineering samples to run a qualification activity.

11.3 VFQFPN32 package information

Figure 48. VFQFPN32 - 32-pin, 5x5 mm, 0.5 mm pitch very thin profile fine pitch quad flat package outline

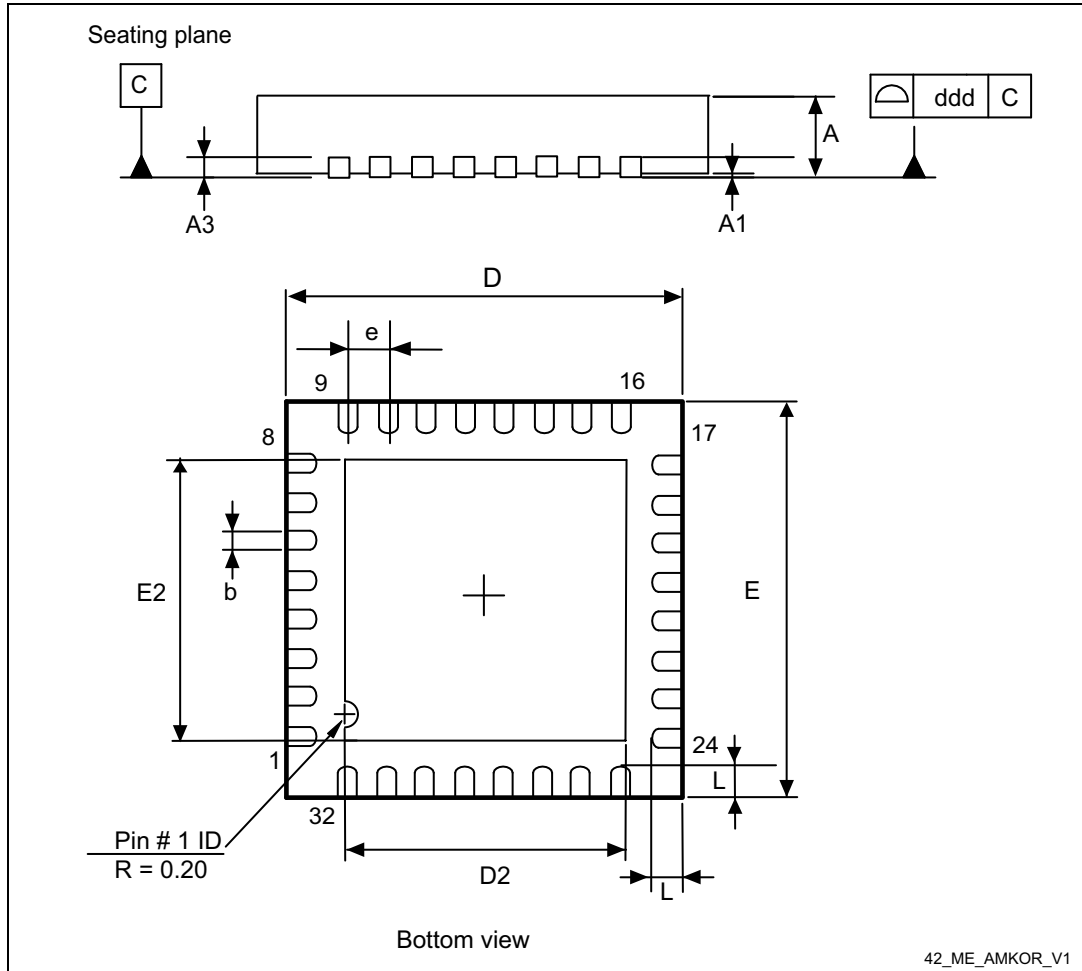

1. Drawing is not to scale.

Table 64. VFQFPN32 - 32-pin, 5x5 mm, 0.5 mm pitch very thin profile fine pitch quad flat package mechanical data

Symbol	millimeters			inches ⁽¹⁾		
	Min	Typ	Max	Min	Typ	Max
A	0.800	0.900	1.000	0.0315	0.0354	0.0394
A1	0.000	0.020	0.050	0.0000	0.0008	0.0020
A3	-	0.200	-	-	0.0079	-
b	0.180	0.250	0.300	0.0071	0.0098	0.0118
D	4.850	5.000	5.150	0.1909	0.1969	0.2028
D2	3.500	3.600	3.700	0.1378	0.1417	0.1457
E	4.850	5.000	5.150	0.1909	0.1969	0.2028
E2	3.500	3.600	3.700	0.1378	0.1417	0.1457
e	-	0.500	-	-	0.0197	-
L	0.300	0.400	0.500	0.0118	0.0157	0.0197
ddd	-	-	0.050	-	-	0.0020

1. Values in inches are converted from mm and rounded to 4 decimal digits.

Figure 49. VFQFPN32 - 32-pin, 5x5 mm, 0.5 mm pitch very thin profile fine pitch quad flat package recommended footprint

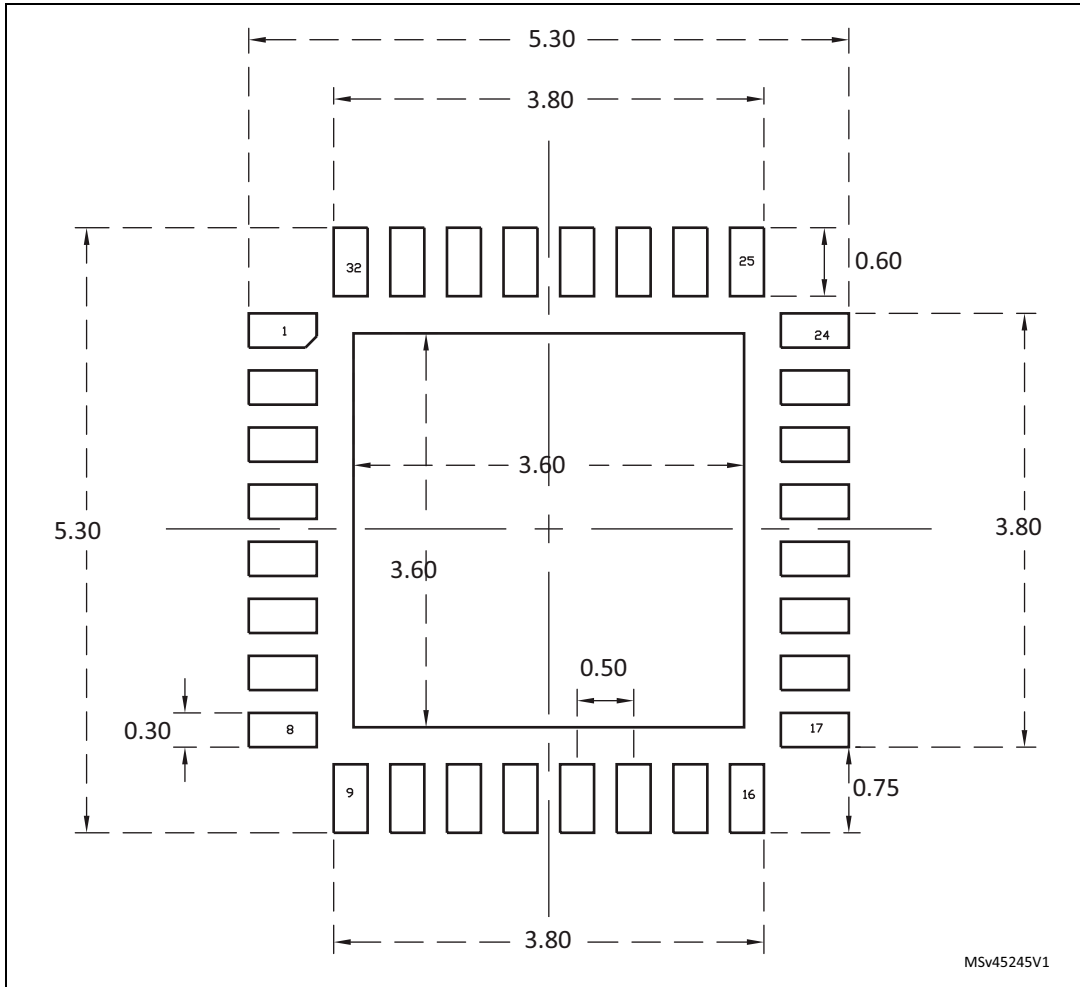

1. Dimensions are expressed in millimeters.

Device marking for VFQFPN32

The following figure gives an example of topside marking orientation versus pin 1 identifier location.

Other optional marking or inset/upset marks, which depend on supply chain operations, are not indicated below.

Figure 50. VFQFPN32 marking example (package top view)

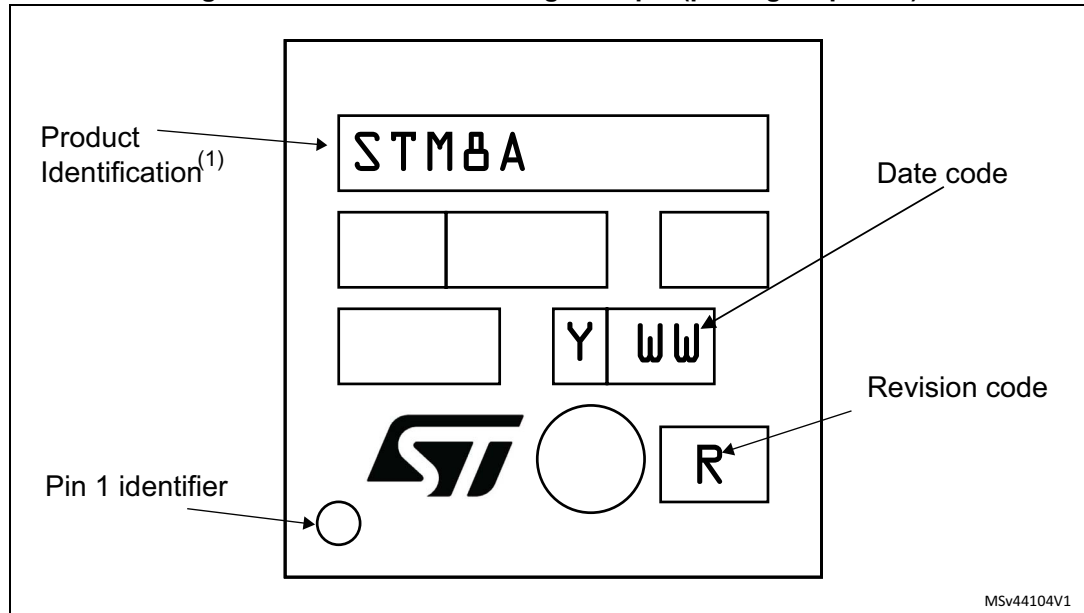

1. Parts marked as “ES” or “E” are not yet qualified and therefore not approved for use in production. ST is not responsible for any consequences resulting from such use. In no event will ST be liable for the customer using any of these engineering samples in production. ST’s Quality department must be contacted prior to any decision to use these engineering samples to run a qualification activity.

11.4 Thermal characteristics

The maximum chip junction temperature (T_{Jmax}) must never exceed the values given in [Table 27: General operating conditions](#).

T_{Jmax} , in degrees Celsius, may be calculated using the following equation:

$$T_{Jmax} = T_{Amax} + (P_{Dmax} \times \Theta_{JA})$$

Where:

- T_{Amax} is the maximum ambient temperature in °C
- Θ_{JA} is the package junction-to-ambient thermal resistance in °C/W
- P_{Dmax} is the sum of P_{INTmax} and $P_{I/Omax}$ ($P_{Dmax} = P_{INTmax} + P_{I/Omax}$)
- P_{INTmax} is the product of I_{DD} and V_{DD} , expressed in Watts. This is the maximum chip internal power.

- $P_{I/Omax}$ represents the maximum power dissipation on output pins
Where:

$$P_{I/Omax} = \Sigma (V_{OL} * I_{OL}) + \Sigma ((V_{DD} - V_{OH}) * I_{OH}),$$

taking into account the actual V_{OL}/I_{OL} and V_{OH}/I_{OH} of the I/Os at low and high level in the application.

Table 65. Thermal characteristics⁽¹⁾

Symbol	Parameter	Value	Unit
Θ_{JA}	Thermal resistance junction-ambient TSSOP20 - 4 x 4 mm	110	°C/W
	Thermal resistance junction-ambient LQFP 32 - 7 x 7 mm	60	
	Thermal resistance junction-ambient VFQFPN32 - 5 x 5 mm	TBD	

1. Thermal resistances are based on JEDEC JESD51-2 with 4-layer PCB in a natural convection environment.

11.4.1 Reference document

JESD51-2 integrated circuits thermal test method environment conditions - natural convection (still air). Available from www.jedec.org.

11.4.2 Selecting the product temperature range

When ordering the microcontroller, the temperature range is specified in the order code (see [Section 12: Ordering information](#)).

The following example shows how to calculate the temperature range needed for a given application.

Assuming the following application conditions:

Maximum ambient temperature $T_{Amax} = 75\text{ °C}$ (measured according to JESD51-2),

$I_{DDmax} = 8\text{ mA}$, $V_{DD} = 5\text{ V}$

Maximum 20 I/Os used at the same time in output at low level with:

$I_{OL} = 8\text{ mA}$, $V_{OL} = 0.4\text{ V}$

$P_{INTmax} = 8\text{ mA} \times 5\text{ V} = 400\text{ mW}$

$P_{IOmax} = 20 \times 8\text{ mA} \times 0.4\text{ V} = 64\text{ mW}$

This gives: $P_{INTmax} = 400\text{ mW}$ and $P_{IOmax} = 64\text{ mW}$:

$P_{Dmax} = 400\text{ mW} + 64\text{ mW}$

Thus: $P_{Dmax} = 464\text{ mW}$.

Using the values obtained in [Table 65: Thermal characteristics on page 103](#) T_{Jmax} is calculated as follows:

For LQFP32 60 °C/W

$T_{Jmax} = 75\text{ °C} + (60\text{ °C/W} \times 464\text{ mW}) = 75\text{ °C} + 27.8\text{ °C} = 102.8\text{ °C}$

This is within the range of the suffix C version parts ($-40 < T_J < 125\text{ °C}$).

Parts must be ordered at least with the temperature range suffix C.

12 Ordering information

Table 66. STM8AF6213/13A/23/23A/26 ordering information scheme⁽¹⁾

Example	STM8A	F	62	2	3	I	P	C	A	U
Product Class⁽²⁾ 8-bit automotive microcontroller										
Program memory type F = Flash + EEPROM										
Device family 62 = LIN only										
Program memory size 1 = 4 Kbyte 2 = 8 Kbyte										
Pin count 3 = 20 pins 6 = 32 pins										
HSI accuracy Blank = ± 5% I = ± 3%										
Package type T = LQFP P = TSSOP U = VFQFPN										
Temperature range A = -40 to 85 °C C = -40 to 125 °C D = -40 to 150 °C										
Number of ADC analog inputs Blank = 5 analog inputs A = 7 analog inputs										
Packing Y = Tray U = Tube X = Tape and reel compliant with EIA 481-C										

1. For a list of available options (e.g. memory size, package) and orderable part numbers or for further information on any aspect of this device, please go to www.st.com or contact the nearest ST Sales Office.
2. Qualified and characterized according to AEC Q100 and Q003 or equivalent, advanced screening according to AEC Q001 and Q002 or equivalent.

13 STM8 development tools

Development tools for the STM8 microcontrollers include the full-featured STice emulation system supported by a complete software tool package including C compiler, assembler and integrated development environment with high-level language debugger. In addition, the STM8 is to be supported by a complete range of tools including starter kits, evaluation boards and a low-cost in-circuit debugger/programmer.

13.1 Emulation and in-circuit debugging tools

The STice emulation system offers a complete range of emulation and in-circuit debugging features on a platform that is designed for versatility and cost-effectiveness. In addition, the STM8 application development is supported by a low-cost in-circuit debugger/programmer.

The STice is the fourth generation of full-featured emulators from STMicroelectronics. It offers new advanced debugging capabilities including coverage to help detect and eliminate bottlenecks in application execution and dead code when fine tuning an application.

In addition, STice offers in-circuit debugging and programming of STM8A microcontrollers via the STM8 single wire interface module (SWIM), which allows non-intrusive debugging of an application while it runs on the target microcontroller.

For improved cost effectiveness, STice is based on a modular design that allows you to order exactly what you need to meet your development requirements and to adapt your emulation system to support existing and future ST microcontrollers.

13.1.1 STice key features

- Occurrence and time profiling and code coverage analysis (new features)
- Advanced breakpoints with up to 4 levels of conditions
- Data breakpoints
- Program and data trace recording up to 128 KB records
- Read/write on-the-fly of memory during emulation
- In-circuit debugging/programming via SWIM protocol
- 8-bit probe analyzer
- 1 input and 2 output triggers
- Power supply follower managing application voltages between 1.62 to 5.5 V
- Modularity that allows you to specify the components you need to meet your development requirements and adapt to future requirements.
- Supported by free software tools that include integrated development environment (IDE), programming software interface and assembler for STM8.

13.2 Software tools

STM8 development tools are supported by a complete, free software package from STMicroelectronics that includes ST visual develop (STVD) IDE and the ST visual programmer (STVP) software interface. STVD provides seamless integration of the Cosmic and Raisonance C compilers for STM8.

13.2.1 STM8 toolset

The STM8 toolset with STVD integrated development environment and STVP programming software is available for free download at www.st.com. This package includes:

ST visual develop

Full-featured integrated development environment from STMicroelectronics, featuring:

- Seamless integration of C and ASM toolsets
- Full-featured debugger
- Project management
- Syntax highlighting editor
- Integrated programming interface
- Support of advanced emulation features for STice such as code profiling and coverage

ST visual programmer (STVP)

Easy-to-use, unlimited graphical interface allowing read, write and verify of your STM8 microcontroller Flash program memory, data EEPROM and option bytes. STVP also offers project mode for saving programming configurations and automating programming sequences.

13.2.2 C and assembly toolchains

Control of C and assembly toolchains is seamlessly integrated into the STVD integrated development environment, making it possible to configure and control the building of the application directly from an easy-to-use graphical interface.

Available toolchains include:

Cosmic C compiler for STM8

All compilers are available in free version with a limited code size depending on the compiler. For more information, refer to www.cosmic-software.com, www.raisonance.com, and www.iar.com.

STM8 assembler linker

Free assembly toolchain included in the STM8 toolset, which allows the users to assemble and link your application source code.

13.3 Programming tools

During the development cycle, STIcice provides in-circuit programming of the STM8 Flash microcontroller on the user application board via the SWIM protocol. Additional tools include a low-cost in-circuit programmer as well as ST socket boards, which provide dedicated programming platforms with sockets for programming the STM8.

For production environments, programmers will include a complete range of gang and automated programming solutions from third-party tool developers already supplying programmers for the STM8 family.

14 Revision history

Table 67. Document revision history

Date	Revision	Changes
11-Oct-2013	1	Initial release.
16-Dec-2013	2	<p>Changed the document status to Production data.</p> <p>Updated <i>Figure: STM8AF6223PxAx TSSOP20 pinout</i> to add SPI_NSS to PD4, TLI to PD2, and change remap function on PB5 from TIM5_BKIn to TIM1_BKIN.</p> <p>Updated <i>Table: STM8AF6223PxAx TSSOP20 pin description</i> to add SPI_NSS to PD4 and TLI to PD2.</p> <p>Updated <i>Table: STM8AF6223 TSSOP20 pin description</i> and <i>Table: LQFP32 pin description</i>.</p> <p>Updated AFR2 definition in <i>Table: STM8AF6223PxAx alternate function remapping bits [7:2] for 20-pin packages</i>.</p> <p>Removed the remapping option on PA3 for AFR[1:0]=10 in <i>Table: STM8AF6223PxAx alternate function remapping bits [1:0] for 20-pin packages</i>.</p> <p>Added note and removed remapping option on PA3 for AFR[1:0]=11 in <i>Table: STM8AF6223 alternate function remapping bits [1:0] for 20-pin packages</i>. Updated AFR2 definition in STM8AF6223 alternate function remapping bits [7:2] for 20-pin packages.</p> <p>Added the note below <i>Table: STM8AF6226T alternate function remapping bits [1:0] for 32-pin packages</i>.</p> <p>Updated <i>Table: I2C characteristics</i> to modify $t_{h(SDA)}$ and add t_{SP}.</p> <p>Updated <i>Section: C assembly toolchains</i>.</p>
03-Apr-2014	3	<p>Replaced STM8AF6226T by STM8AF6226 part number. Added STM8AF6223A part number to cover STM8AF6223PxAx order codes.</p> <p>Removed LINUART alternate function for PA3 in <i>Table: STM8AF6223PxAx TSSOP20 pin description</i>.</p> <p>Removed note 3 for $I_{DD(AH)}$ in <i>Table: Total current consumption in active halt mode at VDD = 5 V</i>.</p> <p>Updated the remapping option on PA3 for AFR[1:0]=11 in <i>Table: STM8AF6223 alternate function remapping bits [1:0] for 20-pin packages</i>.</p> <p>Updated notes related to t_{RET} minimum value in <i>Table: Data memory</i>.</p> <p>Updated <i>Table: ESD absolute maximum ratings</i>.</p> <p>Added notes related to protrusions and gate burrs for D and E1 dimensions in <i>Table: 20-pin, 4.40 mm body, 0.65 mm pitch mechanical data</i>.</p>

Table 67. Document revision history (continued)

Date	Revision	Changes
10-Jul-2014	4	<p>Extended the applicability to STM8AF6213 devices.</p> <p>Updated the program memory feature, the power management, and the clock management features on the cover page.</p> <p>Added the table in <i>Section: Memory map</i>.</p> <p>Updated the <i>Figure: $f_{CPU_{max}}$ versus V_{DD}</i> in <i>Section: Operating conditions</i>.</p> <p>Updated <i>Section: Ordering information</i>.</p>
26-Jun-2015	5	<p>Added:</p> <ul style="list-style-type: none"> – the footnote about the inrush current below <i>Table 28: Operating conditions at power-up/power-down</i>, – <i>Figure 47: LQFP32 marking example (package top view)</i>, – <i>Figure 44: TSSOP20 marking example (package top view)</i>. <p>Updated</p> <ul style="list-style-type: none"> – LIN standard version, – the register label for LINUART block in <i>Table 11: General hardware register map</i>, – the power dissipation in <i>Table 27: General operating conditions</i>, – <i>Table 42: HSI oscillator characteristics</i> for HSI oscillator accuracy, – the standard for EMI in <i>Electromagnetic interference (EMI)</i>, – <i>Figure 48: STM8AF6213/23/23A/26 ordering information scheme⁽¹⁾ ⁽²⁾</i> to add HSI accuracy. <p>Moved <i>Section 11.4: Thermal characteristics</i> to <i>Section 11: Package information</i>.</p>

Table 67. Document revision history (continued)

Date	Revision	Changes
28-Mar-2017	6	<p>Updated <i>Table 6: STM8AF6213/STM8AF6223 TSSOP20 pin description</i></p> <p>Added VFQFPN32 (5x5 mm) package information updating:</p> <ul style="list-style-type: none"> – <i>Section : Features</i> on the cover page: added VFQFPN32 (5x5 mm) figure – Added <i>Section 11.2: LQFP32 package information:</i> – Updated <i>Table 27: General operating conditions</i> – Updated <i>Table 65: Thermal characteristics</i> – Updated <i>Section 5.2: LQFP32/VFQPN32 pinout and pin description</i> – Updated <i>Section 12: Ordering information</i> <p>Additional updates (not related to VFQFPN32):</p> <ul style="list-style-type: none"> – Table footnotes on <i>Section 10: Electrical characteristics</i> – Updated <i>Section : Device marking for LQFP32 on page 98, Section : Device marking for TSSOP20 on page 95 and Section : Device marking for VFQFPN32 on page 102</i> – <i>Section 10.2: Absolute maximum ratings</i>
07-Dec-2017	7	<p>Added:</p> <ul style="list-style-type: none"> – STMAF6213A RPN to the whole document – Footnote ⁽²⁾ on <i>Table 66: STM8AF6213/13A/23/23A/26 ordering information scheme</i> <p>Updated:</p> <ul style="list-style-type: none"> – All document to add STMAF6213A reference where applicable – <i>Table 1: STM8AF6213/13A/23/23A/26 features</i> – Titles of sections <i>Device marking for LQFP32, Device marking for TSSOP20 and Device marking for VFQFPN32</i>
19-Mar-2019	8	<p>Added <i>Section 9: Unique ID</i></p> <p>Updated order of package figures on cover page and order of subsections on <i>Section 11: Package information</i></p>
01-Apr-2020	9	<p>Updated: Table 42: HSI oscillator characteristics</p>

IMPORTANT NOTICE – PLEASE READ CAREFULLY

STMicroelectronics NV and its subsidiaries (“ST”) reserve the right to make changes, corrections, enhancements, modifications, and improvements to ST products and/or to this document at any time without notice. Purchasers should obtain the latest relevant information on ST products before placing orders. ST products are sold pursuant to ST’s terms and conditions of sale in place at the time of order acknowledgement.

Purchasers are solely responsible for the choice, selection, and use of ST products and ST assumes no liability for application assistance or the design of Purchasers’ products.

No license, express or implied, to any intellectual property right is granted by ST herein.

Resale of ST products with provisions different from the information set forth herein shall void any warranty granted by ST for such product.

ST and the ST logo are trademarks of ST. For additional information about ST trademarks, please refer to www.st.com/trademarks. All other product or service names are the property of their respective owners.

Information in this document supersedes and replaces information previously supplied in any prior versions of this document.

© 2020 STMicroelectronics – All rights reserved

Данный компонент на территории Российской Федерации

Вы можете приобрести в компании MosChip.

Для оперативного оформления запроса Вам необходимо перейти по данной ссылке:

<http://moschip.ru/get-element>

Вы можете разместить у нас заказ для любого Вашего проекта, будь то серийное производство или разработка единичного прибора.

В нашем ассортименте представлены ведущие мировые производители активных и пассивных электронных компонентов.

Нашей специализацией является поставка электронной компонентной базы двойного назначения, продукции таких производителей как XILINX, Intel (ex.ALTERA), Vicor, Microchip, Texas Instruments, Analog Devices, Mini-Circuits, Amphenol, Glenair.

Сотрудничество с глобальными дистрибьюторами электронных компонентов, предоставляет возможность заказывать и получать с международных складов практически любой перечень компонентов в оптимальные для Вас сроки.

На всех этапах разработки и производства наши партнеры могут получить квалифицированную поддержку опытных инженеров.

Система менеджмента качества компании отвечает требованиям в соответствии с ГОСТ Р ИСО 9001, ГОСТ РВ 0015-002 и ЭС РД 009

Офис по работе с юридическими лицами:

105318, г.Москва, ул.Щербаковская д.3, офис 1107, 1118, ДЦ «Щербаковский»

Телефон: +7 495 668-12-70 (многоканальный)

Факс: +7 495 668-12-70 (доб.304)

E-mail: info@moschip.ru

Skype отдела продаж:

moschip.ru

moschip.ru_4

moschip.ru_6

moschip.ru_9