

## HLMP-P106/P156

## HLMP-Q102/Q152/Q106/Q156

Subminiature High Performance TS AlGaAs Red LED Lamps



# Data Sheet

### Description

#### Flat Top Package

The HLMP-Pxxx Series flat top lamps use an untinted, non-diffused, truncated lens to provide a wide radiation pattern that is necessary for use in backlighting applications. The flat top lamps are also ideal for use as emitters in light pipe applications.

#### Dome Packages

The HLMP-Qxxx Series dome lamps, for use as indicators, use a tinted, diffused lens to provide a wide viewing angle with high on-off contrast ratio. High brightness lamps use an untinted, nondiffused lens to provide a high luminous intensity within a narrow radiation pattern.

#### Lead Configurations

All of these devices are made by encapsulating LED chips on axial lead frames to form molded epoxy subminiature lamp packages. A variety of package configuration options is available. These include special surface mount lead configurations, gull wing, yoke lead, or Z-bend. Right angle lead bends at 2.54 mm (0.100 inch) and 5.08 mm (0.200 inch) center spacing are available for through hole mounting. For more information refer to Standard SMT and Through Hole Lead Bend Options for Subminiature LED Lamps data sheet.

#### Technology

These subminiature solid state lamps utilize a highly optimized LED material technology, transparent substrate aluminum gallium arsenide (TS AlGaAs). This LED technology has a very high luminous efficiency, capable of producing high light output over a wide range of drive currents (500  $\mu$ A to 50 mA). The color is deep red at a dominant wavelength of 644 nm deep red. TS AlGaAs is a flip-chip LED technology, die attached to the anode lead and wire bonded to the cathode lead. Available viewing angles are 75°, 35°, and 15°.

### Features

- Subminiature flat top package  
Ideal for backlighting and light piping applications
- Subminiature dome package  
Diffused dome for wide viewing angle  
Non-diffused dome for high brightness
- Wide range of drive currents 500  $\mu$ A to 50 mA
- Ideal for space limited applications
- Axial leads
- Available with lead configurations for surface mount and through hole PC board mounting

## Device Selection Guide

| Package Description                                  | Viewing Angle<br>$2\theta_{1/2}$ | Deep Red<br>$R_d = 644\text{ nm}$ | Typical $I_v$<br>$I_f = 500\ \mu\text{a}$ | Typical $I_v$<br>$I_f = 20\ \text{mA}$ | Package Outline |
|--|----------------------------------|-----------------------------------|---|--|-----------------|
| Domed, Diffused Tinted,<br>Standard Current          | 35                               | HLMP-Q102                         |   | 100                                    | B               |
| Domed, Diffused Tinted,<br>Low Current               | 35                               | HLMP-Q152                         | 2   |  | B               |
| Domed, Nondiffused<br>Untinted, Standard Current     | 15                               | HLMP-Q106                         |   | 400                                    | B               |
| Domed, Nondiffused<br>Untinted, Low Current          | 15                               | HLMP-Q156                         | 7   |  | B               |
| Flat Top, Nondiffused,<br>Untinted, Standard Current | 75                               | HLMP-P106                         |   | 130                                    | A               |
| Flat Top, Nondiffused<br>Untinted, Low Current       | 75                               | HLMP-P156                         | 2   |  | A               |

## Ordering Information

HLMX-XXXX-X X X X X

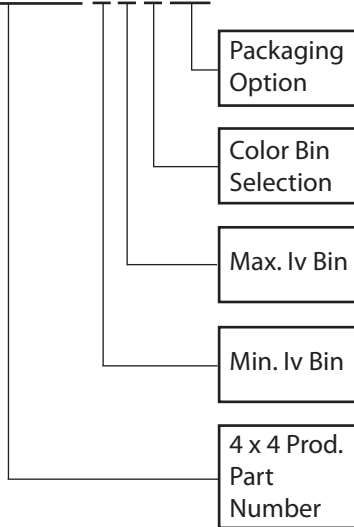

# Package Dimensions

## A) Flat Top Lamps

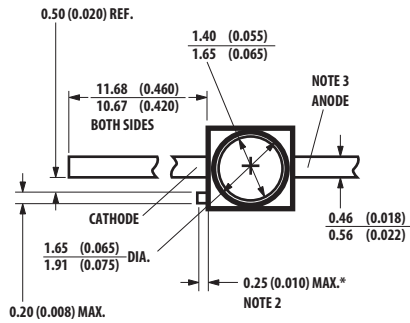

\* REFER TO FIGURE 1 FOR DESIGN CONCERNS.

## B) Diffused and Nondiffused Dome Lamps

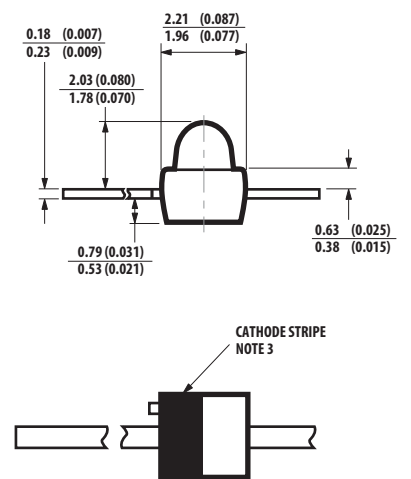
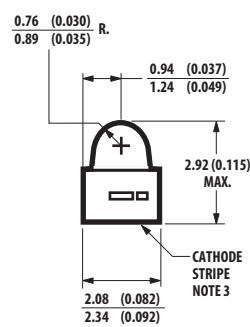
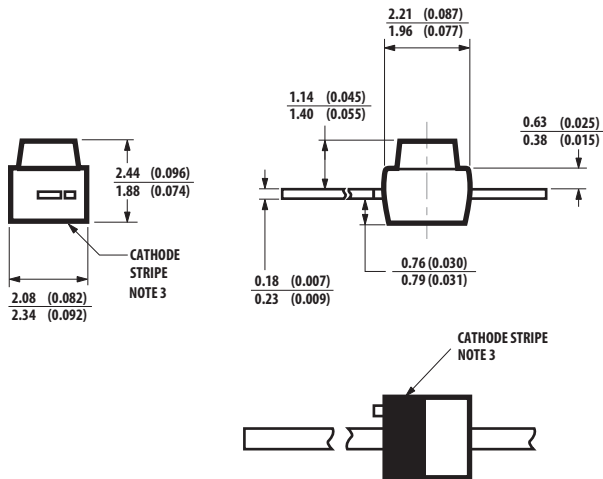
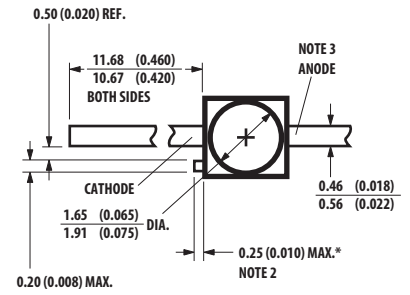

### Notes:

1. All dimensions are in millimetres (inches).
2. Protruding support tab is connected to anode lead.
3. Lead polarity for these TS AlGaAs subminiature lamps is opposite to the lead polarity of subminiature lamps using other led technologies.

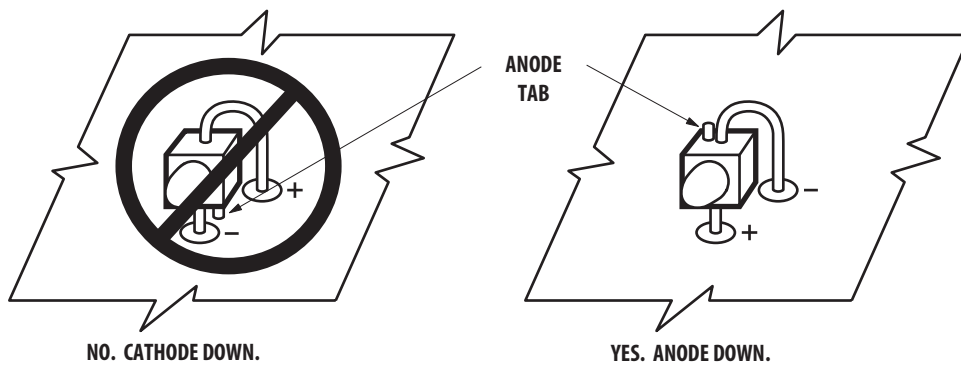

Figure 1. Proper right angle mounting to a PC board to prevent protruding anode tab from shorting to cathode connection.

### Absolute Maximum Ratings at $T_A = 25^\circ\text{C}$

| Parameters  | Title                |
|---|----------------------|
| DC Forward Current <sup>[1]</sup>                                 | 50 mA                |
| Peak Forward Current <sup>[2]</sup>                               | 300 mA               |
| Average Forward Current <sup>[2,3]</sup>                          | 30 mA                |
| Transient Forward Current (10 $\mu\text{s}$ Pulse) <sup>[4]</sup> | 500 mA               |
| Power Dissipation   | 100 mW               |
| Reverse Voltage   | 5 V                  |
| Junction Temperature  | 110°C                |
| Operating Temperature   | -55°C to +100°C      |
| Storage Temperature   | -55°C to +100°C      |
| Lead Soldering Temperature<br>[1.6 mm (0.063 in.) from body]      | 260°C for 5 seconds  |
| Reflow Soldering Temperature                                      | 260°C for 20 seconds |

Notes:

1. Derate linearly as shown in Figure 6.
2. Refer to Figure 7 to establish pulsed operating conditions.
3. Maximum IAVG at  $f = 1$  kHz, DF = 10%.
4. The transient peak current is the maximum non-recurring peak current the device can withstand without damaging the LED die and wire bonds. It is not recommended that the device be operated at peak currents above the Absolute Maximum Peak Forward Current.

### Optical Characteristics at $T_A = 25^\circ\text{C}$

| Part Number<br>HLMP- | Luminous Intensity<br>$I_v$ (mcd)<br>@ 20 mA <sup>[1]</sup> |      | Total Flux<br>$\phi_v$ (lm)<br>@ 20 mA <sup>[2]</sup> | Peak<br>Wavelength<br>$\lambda_{\text{peak}}$ (nm) | Color, Dominant<br>Wavelength<br>$\lambda_d$ <sup>[3]</sup> (nm) | Viewing Angle<br>$2\theta_{1/2}$<br>Degrees <sup>[4]</sup> | Luminous<br>Efficacy<br>$\eta_v$ <sup>[5]</sup><br>(lm/w) |
|----------------------|---|------|---|--|--|--|---|
|                      | Min.  | Typ. | Typ.  | Typ.   | Typ.   | Typ.   |   |
| Q106-R00xx           | 100   | 400  | 280   | 654  | 644  | 15   | 85  |
| Q102-N00xx           | 25  | 100  | -   | 654  | 644  | 35   | 85  |
| P106-Q00xx           | 63  | 130  | 280   | 654  | 644  | 75   | 85  |

### Optical Characteristics at $T_A = 25^\circ\text{C}$

| Part Number<br>(Low Current)<br>HLMP- | Luminous Intensity<br>$I_v$ (mcd)<br>@ 0.5 mA <sup>[1]</sup> |      | Total Flux<br>$\phi_v$ (lm)<br>@ 0.5 mA <sup>[2]</sup> | Peak<br>Wavelength<br>$\lambda_{\text{peak}}$ (nm) | Color, Dominant<br>Wavelength<br>$\lambda_d$ <sup>[3]</sup> (nm) | Viewing Angle<br>$2\theta_{1/2}$<br>Degrees <sup>[4]</sup> | Luminous<br>Efficacy<br>$\eta_v$ <sup>[5]</sup><br>(lm/w) |
|---------------------------------------|--|------|--|--|--|--|---|
|                                       | Min.   | Typ. | Typ.   | Typ.   | Typ.   | Typ.   |   |
| Q156-H00xx                            | 2.5  | 7    | 10.5   | 654  | 644  | 15   | 85  |
| Q152-G00xx                            | 1.6  | 2    | -  | 654  | 644  | 35   | 85  |
| P156-EG0xx                            | 0.63   | 2    | 10.5   | 654  | 644  | 75   | 85  |

Notes:

1. The luminous intensity,  $I_v$ , is measured at the mechanical axis of the lamp package. The actual peak of the spatial radiation pattern may not be aligned with this axis.
2.  $\phi_v$  is the total luminous flux output as measured with an integrating sphere.
3. The dominant wavelength,  $\lambda_d$ , is derived from the CIE Chromaticity Diagram and represents the color of the device.
4.  $\theta_{1/2}$  is the off-axis angle where the luminous intensity is 1/2 the peak intensity.
5. Radiant intensity,  $I_v$ , in watts/steradian, may be calculated from the equation  $I_v = I_v/\eta_v$ , where  $I_v$  is the luminous intensity in candelas and  $\eta_v$  is the luminous efficacy in lumens/watt.

### Electrical Characteristics at $T_A = 25^\circ\text{C}$

| Part Number | Forward Voltage $V_F$ (Volts) @ $I_F = 20\text{ mA}$ |      | Reverse Breakdown $V_R$ (Volts) @ $I_R = 100\ \mu\text{A}$ |      | Capacitance $C$ (pF) $V_F = 0$ , $f = 1\text{ MHz}$ | Thermal Resistance $R\theta_{J-PIN}$ ( $^\circ\text{C/W}$ ) | Speed of Response $\tau_s$ (ns) Time Constant $e^{-t/\tau_s}$ |
|-------------|--|------|--|------|---|---|---|
|             | Typ.   | Max. | Min.   | Typ. |   |   |   |
| Q106        | 1.9  | 2.4  | 5  | 20   | 20  | 170   | 45  |
| Q102        | 1.9  | 2.4  | 5  | 20   | 20  | 170   | 45  |
| P106        | 1.9  | 2.4  | 5  | 20   | 20  | 170   | 45  |

### Electrical Characteristics at $T_A = 25^\circ\text{C}$

| Part Number (Low Current) | Forward Voltage $V_F$ (Volts) @ $I_F = 0.5\text{ mA}$ |      | Reverse Breakdown $V_R$ (Volts) @ $I_R = 100\ \mu\text{A}$ |      | Capacitance $C$ (pF) $V_F = 0$ , $f = 1\text{ MHz}$ | Thermal Resistance $R\theta_{J-PIN}$ ( $^\circ\text{C/W}$ ) | Speed of Response $\tau_s$ (ns) Time Constant $e^{-t/\tau_s}$ |
|---------------------------|---|------|--|------|---|---|---|
|                           | Typ.  | Max. | Min.   | Typ. |   |   |   |
| Q156                      | 1.6   | 1.9  | 5  | 20   | 20  | 170   | 45  |
| Q152                      | 1.6   | 1.9  | 5  | 20   | 20  | 170   | 45  |
| P156                      | 1.6   | 1.9  | 5  | 20   | 20  | 170   | 45  |

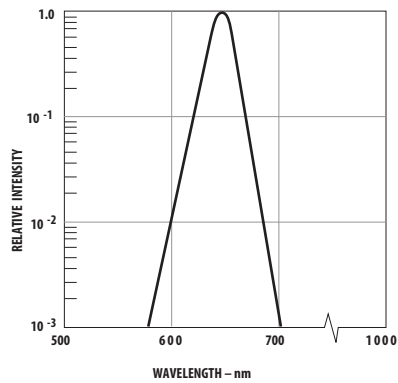

Figure 2. Relative intensity vs. wavelength.

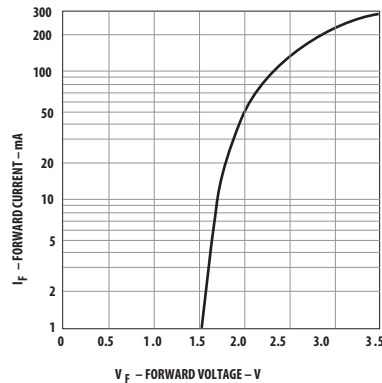

Figure 3. Forward current vs. forward voltage.

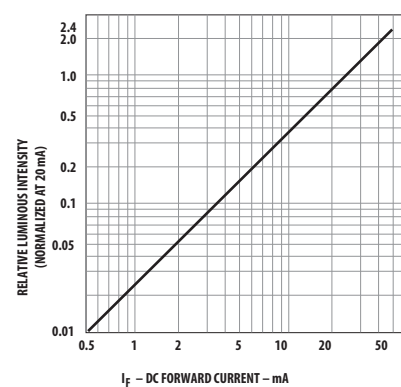

Figure 4. Relative luminous intensity vs. DC forward current.

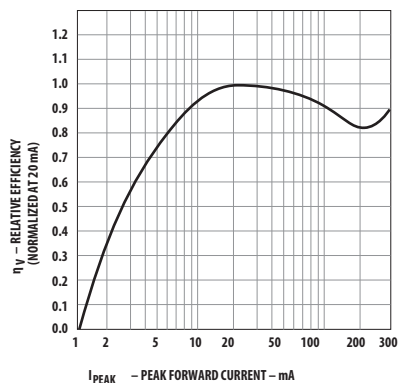

Figure 5. Relative efficiency vs. peak forward current.

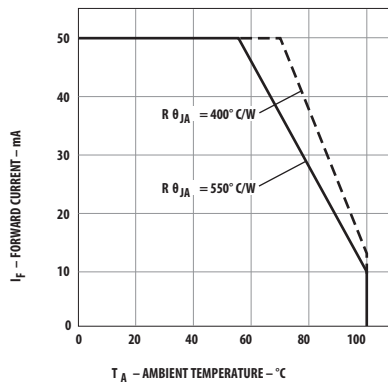

Figure 6. Maximum forward DC current vs. ambient temperature. Derating based on  $T_{JMAX} = 110^\circ\text{C}$ .

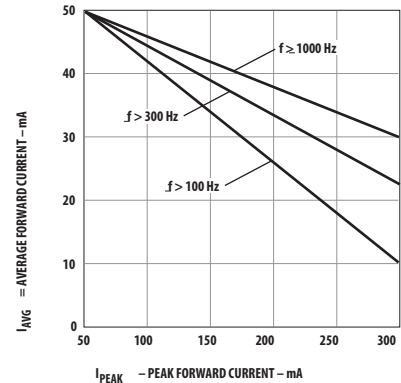

Figure 7. Maximum average current vs. peak forward current.

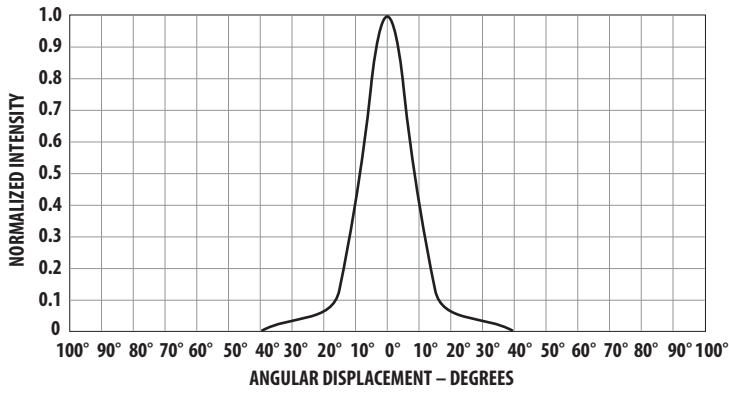

Figure 8. HLMP-Q106/-Q156.

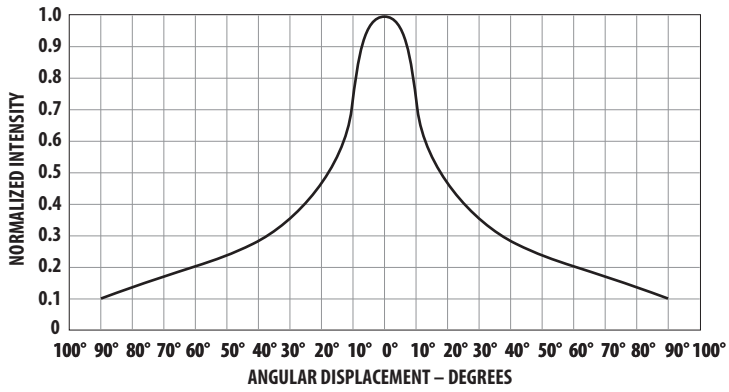

Figure 9. HLMP-Q102/-Q152

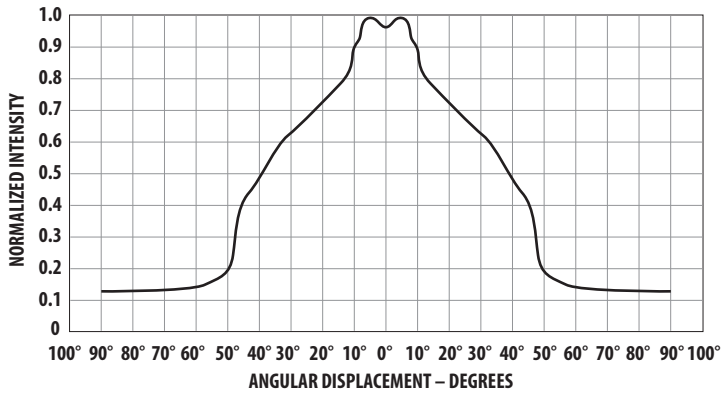

Figure 10. HLMP-P106/-P156.

### Intensity Bin Limits

| Bin | Min.    | Max.    |
|-----|---------|---------|
| E   | 0.63    | 1.25    |
| F   | 1.00    | 2.00    |
| G   | 1.60    | 3.20    |
| H   | 2.50    | 5.00    |
| J   | 4.00    | 8.00    |
| K   | 6.30    | 12.50   |
| L   | 10.00   | 20.00   |
| M   | 16.00   | 32.00   |
| N   | 25.00   | 50.00   |
| P   | 40.00   | 80.00   |
| Q   | 63.00   | 125.00  |
| R   | 100.00  | 200.00  |
| S   | 160.00  | 320.00  |
| T   | 250.00  | 500.00  |
| U   | 400.00  | 800.00  |
| V   | 630.00  | 1250.00 |
| W   | 1000.00 | 2000.00 |
| X   | 1600.00 | 3200.00 |
| Y   | 2500.00 | 5000.00 |

### Color Bin Limits

| Package | Bin | Min.              | Max. |
|---------|-----|-------------------|------|
| Red     | 0   | Full Distribution |      |

### Mechanical Option

|    |  |
|----|--|
| 00 | Straight Leads, Bulk Packaging, Quantity of 500 Parts                |
| 11 | Gull Wing Leads, 12 mm Tape on 7 in. Dia. Reel, 1500 Parts per Reel  |
| 12 | Gull Wing Lead, Bulk Packaging, Quantity of 500 Parts                |
| 14 | Gull Wing Leads, 12 mm Tape on 13 in. Dia. Reel, 6000 Parts per Reel |
| 21 | Yoke Leads, 12 mm Tape on 7 in. Dia. Reel, 1500 Parts per Reel       |
| 22 | Yoke Leads, Bulk Packaging, Quantity of 500 Parts                    |
| 24 | Yoke Leads, 12 mm Tape on 13 in. Dia. Reel, 6000 Parts per Reel      |
| 31 | Z-Bend Leads, 12 mm Tape on 7 in. Dia. Reel, 1500 Parts per Reel     |
| 32 | Z-Bend Leads, Bulk Packaging, Quantity of 500 Parts                  |
| 34 | Z-Bend Leads, 12 mm Tape on 13 in. Dia. Reel, 6000 Parts per Reel    |

Note:

All Categories are established for classification of products. Products may not be available in all categories. Please contact your local Avago representative for further clarification/information.

For product information and a complete list of distributors, please go to our web site: [www.avagotech.com](http://www.avagotech.com)



## Данный компонент на территории Российской Федерации

### Вы можете приобрести в компании MosChip.

Для оперативного оформления запроса Вам необходимо перейти по данной ссылке:

<http://moschip.ru/get-element>

Вы можете разместить у нас заказ для любого Вашего проекта, будь то серийное производство или разработка единичного прибора.

В нашем ассортименте представлены ведущие мировые производители активных и пассивных электронных компонентов.

Нашей специализацией является поставка электронной компонентной базы двойного назначения, продукции таких производителей как XILINX, Intel (ex.ALTERA), Vicor, Microchip, Texas Instruments, Analog Devices, Mini-Circuits, Amphenol, Glenair.

Сотрудничество с глобальными дистрибьюторами электронных компонентов, предоставляет возможность заказывать и получать с международных складов практически любой перечень компонентов в оптимальные для Вас сроки.

На всех этапах разработки и производства наши партнеры могут получить квалифицированную поддержку опытных инженеров.

Система менеджмента качества компании отвечает требованиям в соответствии с ГОСТ Р ИСО 9001, ГОСТ РВ 0015-002 и ЭС РД 009

### Офис по работе с юридическими лицами:

105318, г.Москва, ул.Щербаковская д.3, офис 1107, 1118, ДЦ «Щербаковский»

Телефон: +7 495 668-12-70 (многоканальный)

Факс: +7 495 668-12-70 (доб.304)

E-mail: [info@moschip.ru](mailto:info@moschip.ru)

Skype отдела продаж:

moschip.ru

moschip.ru\_4

moschip.ru\_6

moschip.ru\_9