

# CGHV27030S

## 30 W, DC - 6.0 GHz, GaN HEMT

The CGHV27030S is an unmatched, gallium nitride (GaN) high electron mobility transistor (HEMT) which offers high efficiency, high gain and wide bandwidth capabilities. The CGHV27030S GaN HEMT devices are ideal for telecommunications applications with frequencies of 700-960 MHz, 1200-1400 MHz, 1800-2200 MHz, 2500-2700 MHz, and 3300-3700 MHz at both 50 V and 28 V operations. The CGHV27030S is also ideal for tactical communications applications operating from 20-2500 MHz, including land mobile radios. Additional applications include L-Band RADAR and S-Band RADAR. The CGHV27030S can operate with either a 50 V or 28 V rail. The transistor is available in a 3mm x 4mm, surface mount, dual-flat-no-lead (DFN) package.



Package Type: 3x4 DFN  
PN: CGHV27030S

### Typical Performance 2.5-2.7 GHz ( $T_c = 25^\circ\text{C}$ ), 50 V

Parameter	2.5 GHz	2.6 GHz	2.7 GHz	Units
Small Signal Gain	23.0	22.0	21.4	dB
Adjacent Channel Power @ $P_{OUT} = 5\text{ W}$	-34.5	-36.5	-37.0	dBc
Drain Efficiency @ $P_{OUT} = 5\text{ W}$	29.5	31.5	32.9	%
Input Return Loss	13.4	9.5	10.4	dB

**Note:**

Measured in the CGHV27030S-AMP1 application circuit, under 7.5 dB PAR single carrier WCDMA signal test model 1 with 64 DPCH.

### Features for 50 V in CGHV27030S-AMP1

- 2.5 - 2.7 GHz Operation
- 30 W Typical Output Power
- 21 dB Gain at 5 W  $P_{AVE}$
- -36 dBc ACLR at 5 W  $P_{AVE}$
- 32% efficiency at 5 W  $P_{AVE}$
- High degree of APD and DPD correction can be applied

Large Signal Models Available for ADS and MWO

### Listing of Available Hardware Application Circuits / Demonstration Circuits

Application Circuit	Operating Frequency	Amplifier Class	Operating Voltage
CGHV27030S-AMP1	2.5 - 2.7 GHz	Class A/B	50 V
CGHV27030S-AMP2	2.5 - 2.7 GHz	Class A/B	28 V
CGHV27030S-AMP3	1.8 - 2.2 GHz	Class A/B	28 V
CGHV27030S-AMP4	1.8 - 2.2 GHz	Class A/B	50 V
CGHV27030S-AMP5	1.2 - 1.4 GHz	Class A/B	50 V

## Absolute Maximum Ratings (not simultaneous) at 25°C Case Temperature

Parameter	Symbol	Rating	Units	Notes
Drain-Source Voltage	$V_{DS}$	125	Volts	25°C
Gate-to-Source Voltage	$V_{GS}$	-10, +2	Volts	25°C
Storage Temperature	$T_{STG}$	-65, +150	°C	
Operating Junction Temperature	$T_J$	225	°C	
Maximum Forward Gate Current	$I_{GMAX}$	4	mA	25°C
Maximum Drain Current <sup>1</sup>	$I_{DMAX}$	1.5	A	25°C
Soldering Temperature <sup>2</sup>	$T_S$	245	°C	
Case Operating Temperature <sup>3</sup>	$T_C$	-40, +150	°C	
Thermal Resistance, Junction to Case <sup>4</sup>	$R_{\theta JC}$	6.18	°C/W	85°C

Note:

<sup>1</sup> Current limit for long term, reliable operation

<sup>2</sup> Refer to the Application Note on soldering at [www.cree.com/rf/document-library](http://www.cree.com/rf/document-library)

<sup>3</sup>  $T_C$  = Case temperature for the device. It refers to the temperature at the ground tab underneath the package. The PCB will add additional thermal resistance. See also, the Power Dissipation De-rating Curve on page 12.

<sup>4</sup> Measured for the CGHV27030S at  $P_{DISS} = 12$  W

<sup>5</sup> The  $R_{\theta TH}$  for Cree's demonstration amplifier, CGHV27030S-AMP1, with 33 x 0.011 via holes designed on a 20 mil thick Rogers 4350 PCB, is 3.9°C. The total  $R_{\theta TH}$  from the heat sink to the junction is 6.18°C + 3.9°C = 10.08°C/W.

## Electrical Characteristics ( $T_C = 25^\circ\text{C}$ )

Characteristics	Symbol	Min.	Typ.	Max.	Units	Conditions
<b>DC Characteristics<sup>1</sup></b>						
Gate Threshold Voltage	$V_{GS(th)}$	-3.8	-3.0	-2.3	$V_{DC}$	$V_{DS} = 10$ V, $I_D = 4$ mA
Gate Quiescent Voltage	$V_{GS(Q)}$	-	-2.7	-	$V_{DC}$	$V_{DS} = 50$ V, $I_D = 0.13$ mA
Saturated Drain Current	$I_{DS}$	3.0	3.6	-	A	$V_{DS} = 6.0$ V, $V_{GS} = 2.0$ V
Drain-Source Breakdown Voltage	$V_{(BR)DSS}$	150	-	-	$V_{DC}$	$V_{GS} = -8$ V, $I_D = 4$ mA
<b>RF Characteristics<sup>2,3</sup> (<math>T_C = 25^\circ\text{C}</math>, <math>F_0 = 2.7</math> GHz unless otherwise noted)</b>						
Gain	G	-	20.7	-	dB	$V_{DD} = 50$ V, $I_{DQ} = 0.13$ A, $P_{OUT} = 37$ dBm
WCDMA Linearity <sup>4</sup>	ACLR	-	-37	-	dBc	$V_{DD} = 50$ V, $I_{DQ} = 0.13$ A, $P_{OUT} = 37$ dBm
Drain Efficiency <sup>4</sup>	$\eta$	-	32.9	-	%	$V_{DD} = 50$ V, $I_{DQ} = 0.13$ A, $P_{OUT} = 37$ dBm
Output Mismatch Stress	VSWR	-	10 : 1	-	Y	No damage at all phase angles, $V_{DD} = 50$ V, $I_{DQ} = 0.13$ A, $P_{OUT} = 37$ dBm
<b>Dynamic Characteristics</b>						
Input Capacitance <sup>5</sup>	$C_{GS}$	-	5.38	-	pF	$V_{DS} = 50$ V, $V_{gs} = -8$ V, $f = 1$ MHz
Output Capacitance <sup>5</sup>	$C_{DS}$	-	1.18	-	pF	$V_{DS} = 50$ V, $V_{gs} = -8$ V, $f = 1$ MHz
Feedback Capacitance	$C_{GD}$	-	0.12	-	pF	$V_{DS} = 50$ V, $V_{gs} = -8$ V, $f = 1$ MHz

Notes:

<sup>1</sup> Measured on wafer prior to packaging

<sup>2</sup> Scaled from PCM data

<sup>3</sup> Measured in Cree's production test fixture. This fixture is designed for high volume test at 2.7 GHz

<sup>4</sup> Single Carrier WCDMA, 3GPP Test Model 1, 64 DPCH, 45% Clipping, PAR = 7.5 dB @ 0.01% Probability on CCDF

<sup>5</sup> Includes package parasitics.

## Typical Performance in Application Circuit CGHV27030S-AMP1

Figure 1. - Small Signal Gain and Return Losses vs Frequency  
 $V_{DD} = 50\text{ V}, I_{DQ} = 0.13\text{ A}$

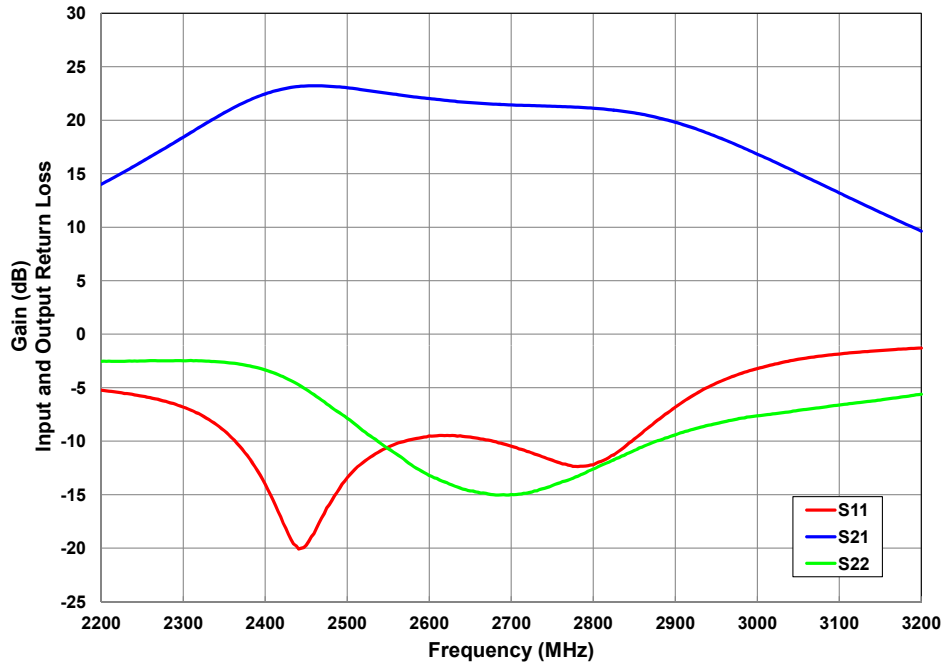
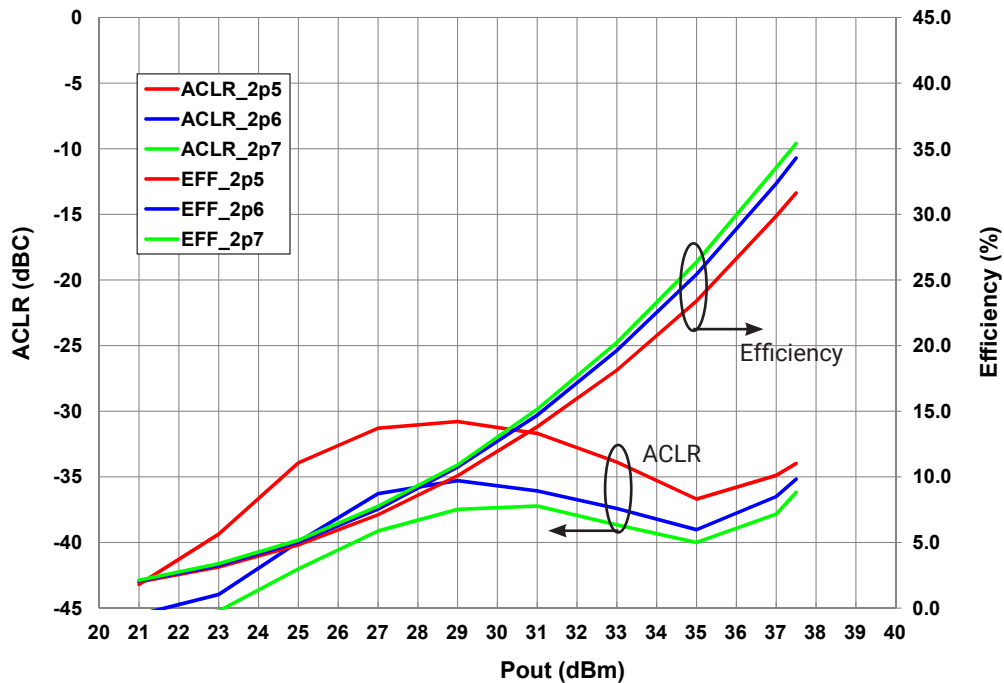
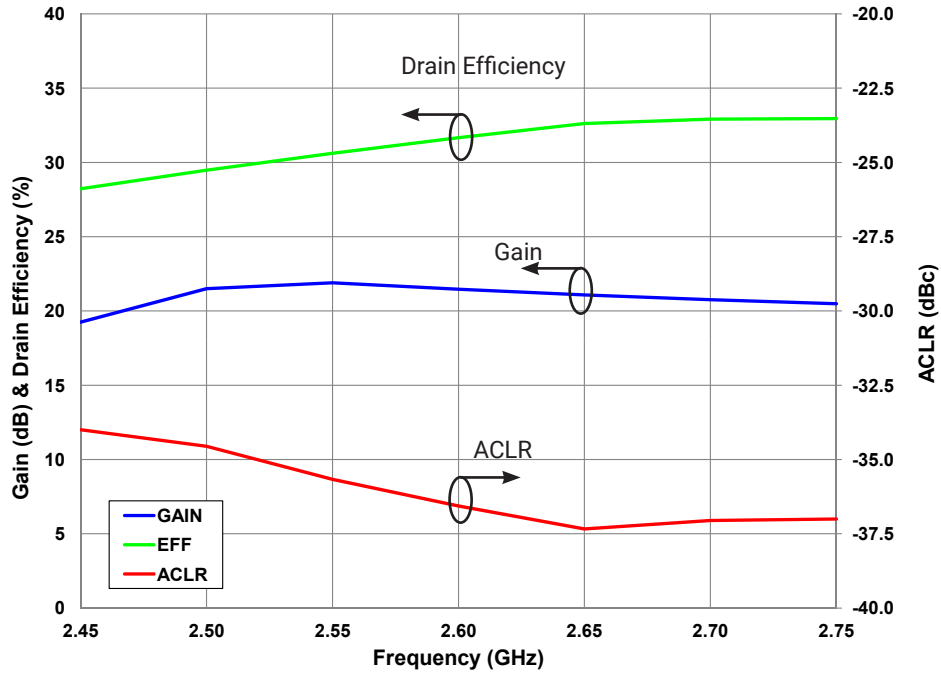


Figure 2. - Typical Drain Efficiency and ACLR vs. Output Power  
 $V_{DD} = 50\text{ V}, I_{DQ} = 0.13\text{ A}, 1\text{c WCDMA}, \text{PAR} = 7.5\text{ dB}$

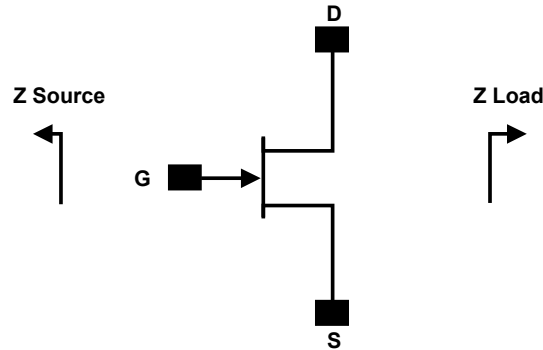


## Typical Performance in Application Circuit CGHV27030S-AMP1

**Figure 3. - Typical Gain, Drain Efficiency and ACLR vs Frequency**  
 $V_{DD} = 50\text{ V}$ ,  $I_{DQ} = 0.13\text{ A}$ ,  $P_{AVE} = 5\text{ W}$ , 1c WCDMA, PAR = 7.5 dB



## Source and Load Impedances for Application Circuit CGHV27030S-AMP1



Frequency (MHz)	Z Source	Z Load
2500	2.2 - j0.7	10.9 + j15.7
2600	2.8 - j1.1	11.5 + j16.7
2700	2.5 - j1.7	12.1 + j17.7

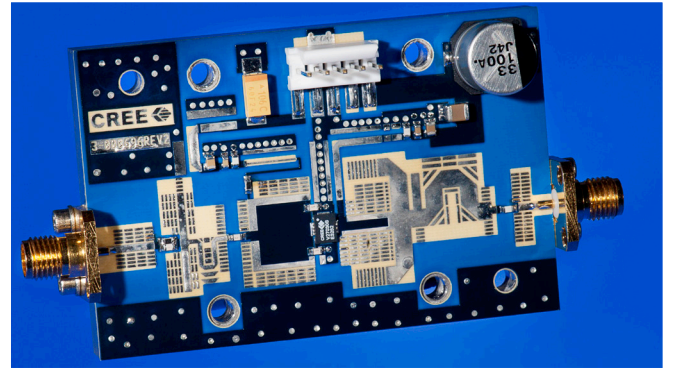
Note<sup>1</sup>:  $V_{DD} = 50\text{ V}$ ,  $I_{DQ} = 0.13\text{ A}$  in the DFN package.

Note<sup>2</sup>: Impedances are extracted from the CGHV27030S-AMP1 application circuit and are not source and load pull data derived from the transistor.

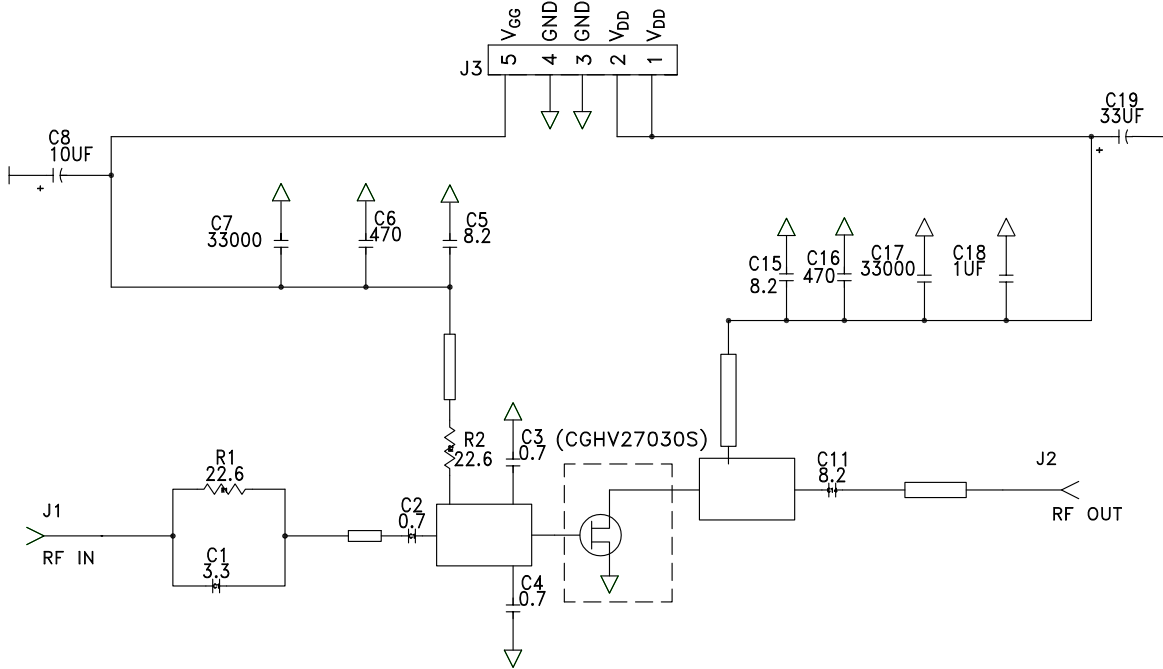
### CGHV27030S-AMP1 Bill of Materials

Designator	Description	Qty
R1, R2	RES, 22.6, OHM, +/-1%, 1/16W, 0603	2
C1	CAP, 3.3 pF, ±0.1 pF, 0603, ATC	1
C2, C3, C4	CAP, 0.7 pF, ±0.05 pF, 0603, ATC	3
C5, C11, C15	CAP, 8.2 pF, ±0.25 pF, 0603, ATC	3
C6, C16	CAP, 470 pF, 5%, 100 V, 0603	2
C7, C17	CAP, 33000 pF, 0805, 100 V, 0603, X7R	2
C18	CAP, 1.0 uF, 100 V, 10%, X7R, 1210	1
C8	CAP, 10 uF 16 V TANTALUM	1
C19	CAP, 33 uF, 20%, G CASE	1
J1, J2	CONN, SMA, PANEL MOUNT JACK, FLANGE, 4-HOLE, BLUNT POST	2
J3	HEADER RT>PLZ .1CEN LK 5 POS	1
PCB	PCB, ROGERS 4350, ER 3.66	1
Q1	CGHV27030S, QFN	1

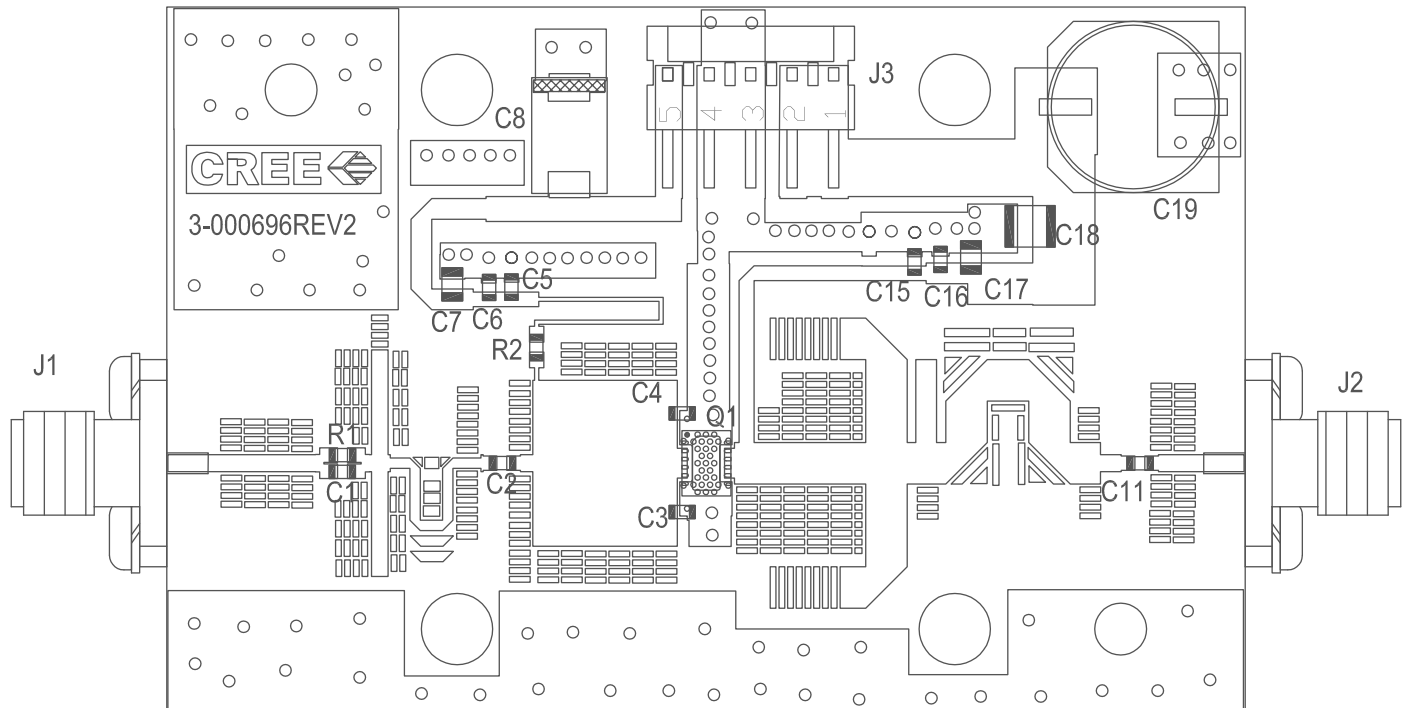
### CGHV27030S -AMP1 Application Circuit



## CGHV27030S-AMP1 Application Circuit Schematic, 50 V



## CGHV27030S-AMP1 Application Circuit Outline, 50 V

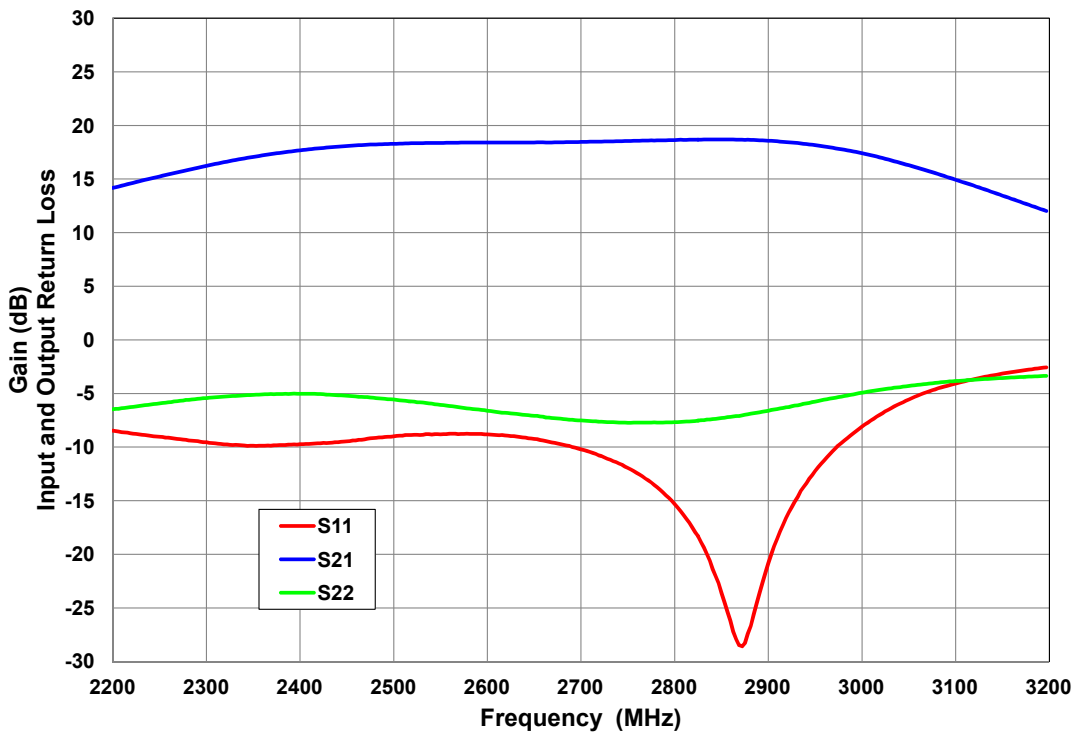


### Electrical Characteristics When Tested in CGHV27030S-AMP2, 28 V, 2.5 - 2.7 GHz

Parameter	2.5 GHz	2.6 GHz	2.7 GHz	Units
Small Signal Gain	15.5	15.7	16.0	dB
Adjacent Channel Power @ $P_{OUT} = 3.2$ W	-42.0	-41.7	-41.2	dBc
Drain Efficiency @ $P_{OUT} = 3.2$ W	33.5	34.2	34.1	%
Input Return Loss	-9.0	-8.8	-10.2	dB

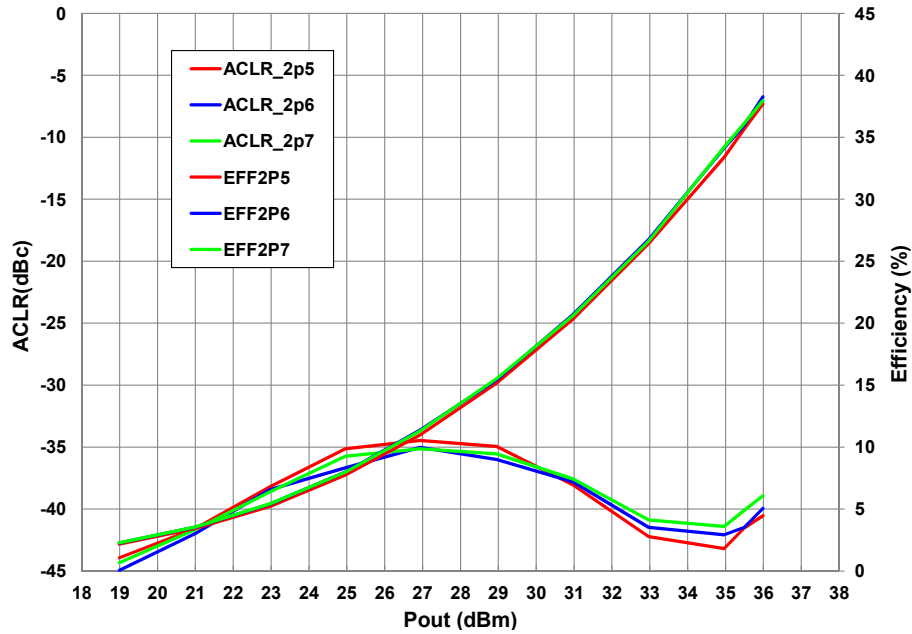
Figure 4. - Small Signal Gain and Return Losses vs Frequency

$V_{DD} = 28$  V,  $I_{DQ} = 0.13$  A

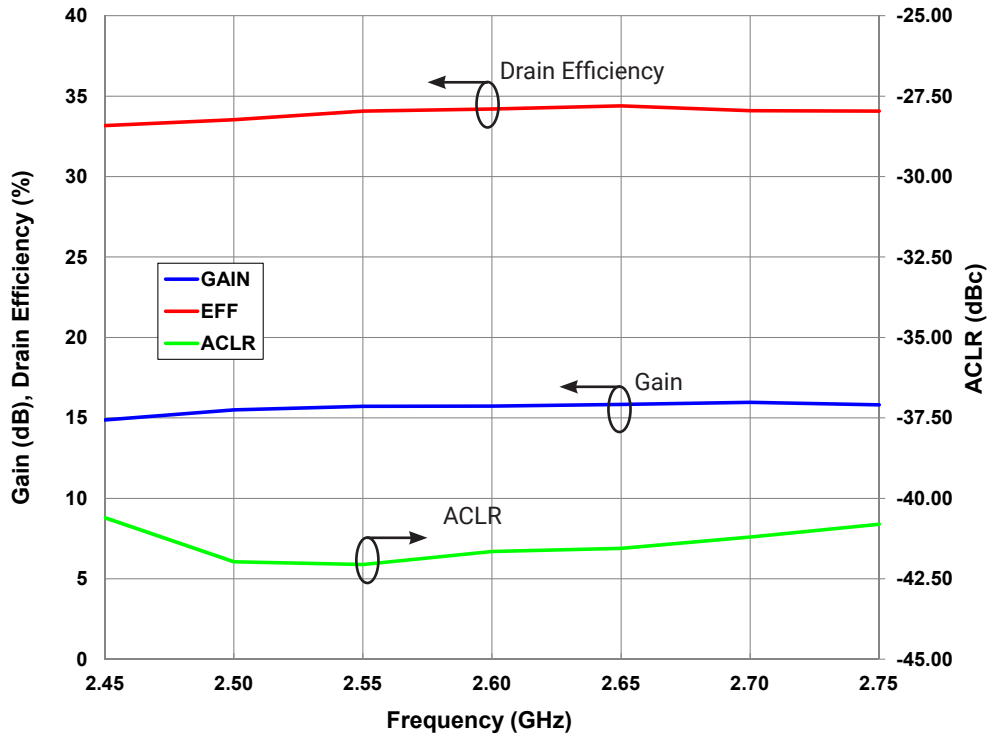


## Typical Performance in Application Circuit CGHV27030S-AMP2

**Figure 5. - Typical Drain Efficiency and ACLR vs. Output Power**  
 $V_{DD} = 28\text{ V}$ ,  $I_{DQ} = 0.13\text{ A}$ , 1c WCDMA, PAR = 7.5 dB

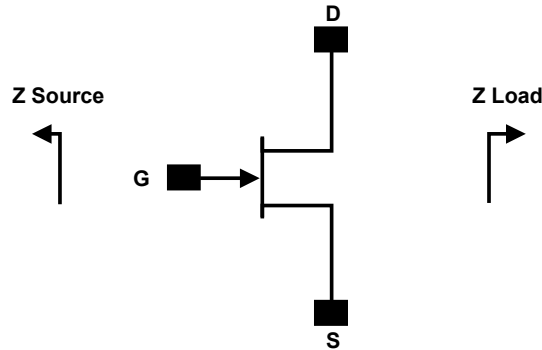


**Figure 6. - Typical Gain, Drain Efficiency and ACLR vs Frequency**  
 $V_{DD} = 28\text{ V}$ ,  $I_{DQ} = 0.13\text{ A}$ ,  $P_{AVE} = 3.2\text{ W}$ , 1c WCDMA, PAR = 7.5 dB





## Source and Load Impedances for Application Circuit CGHV27030S-AMP2



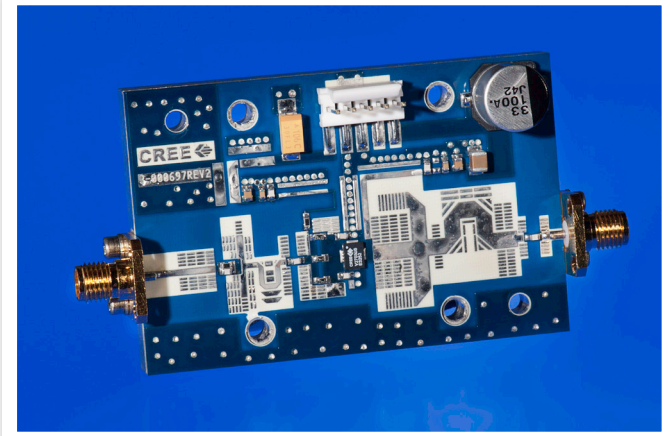
Frequency (MHz)	Z Source	Z Load
2500	2.9 - j2.7	14.5 + j7.4
2600	3.1 - j2.9	13.8 + j7.3
2700	2.7 - j3.1	12.9+j7.6

Note<sup>1</sup>:  $V_{DD} = 28\text{ V}$ ,  $I_{DQ} = 0.13\text{ A}$  in the DFN package.  
 Note<sup>2</sup>: Impedances are extracted from the CGHV27030S-AMP2 application circuit and are not source and load pull data derived from the transistor

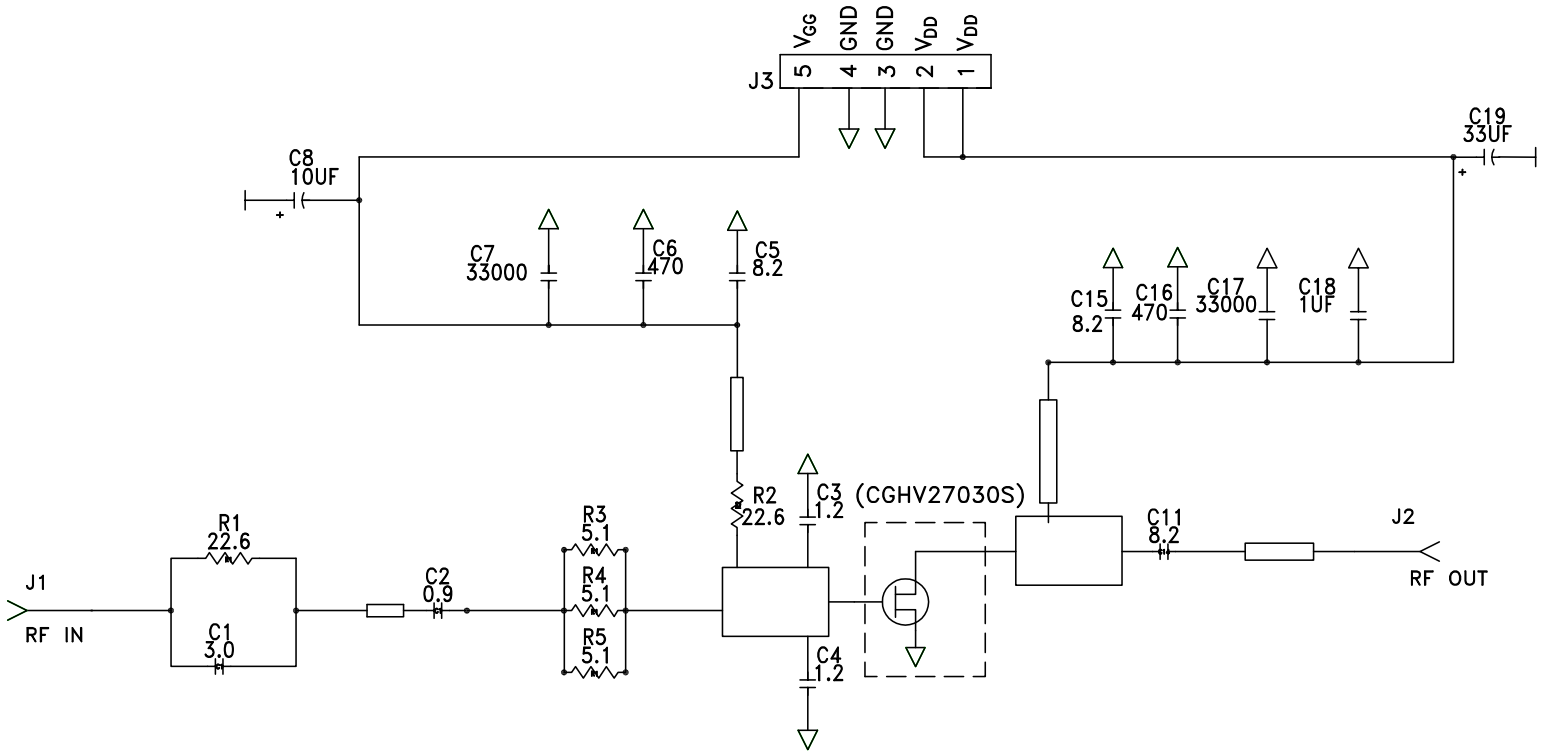
## CGHV27030S-AMP2 Bill of Materials

Designator	Description	Qty
R1, R2	RES, 22.6, OHM, +/-1%, 1/16W, 0603	2
C1	CAP, 3.0 pF, ±0.1 pF, 0603, ATC	1
C2	CAP, 0.9 pF, ±0.05 pF, 0603, ATC	3
R3,R4,R5	RES, 1/16W, 0603, 1%, 5.1% OHMS	3
C3,C4	CAP, 1.2 pF, +/-0.1 pF, 0603, ATC	2
C5, C11, C15	CAP, 8.2 pF, ±0.25 pF, 0603, ATC	3
C6, C16	CAP, 470 pF, 5%, 100 V, 0603	2
C7, C17	CAP, 33000 pF, 0805, 100 V, 0603, X7R	2
C18	CAP, 1.0 UF, 100 V, 10%, X7R, 1210	1
C8	CAP, 10 UF 16 V TANTALUM	1
C19	CAP, 33 UF, 20%, G CASE	1
J1, J2	CONN, SMA, PANEL MOUNT JACK	2
J3	HEADER RT>PLZ .1CEN LK 5 POS	1
PCB	PCB, ROGERS 4350, ER 3.66	1
Q1	CGHV27030S, QFN	1

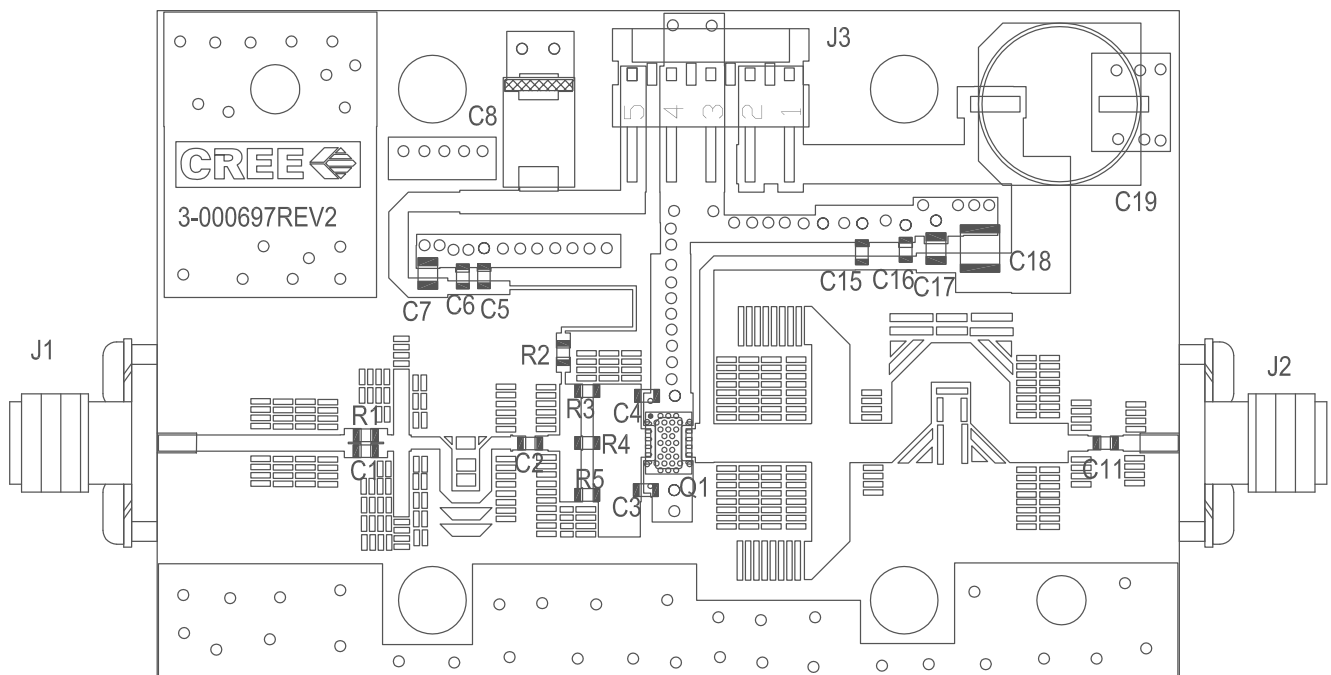
## CGHV27030S-AMP2 Application Circuit



## CGHV27030S-AMP2 Application Circuit Schematic, 28 V



## CGHV27030S-AMP2 Application Circuit Outline, 28 V

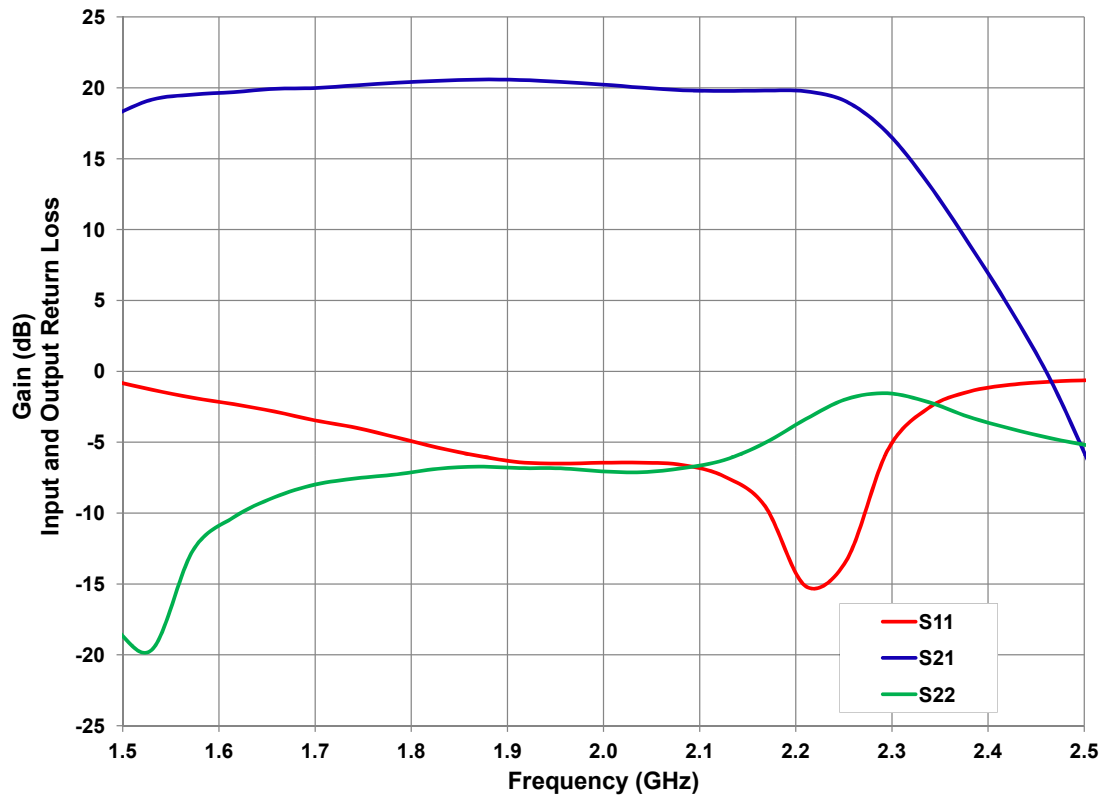


## Electrical Characteristics When Tested in CGHV27030S-AMP3, 28 V, 1.8 - 2.2 GHz

Parameter	1.8 GHz	2.0 GHz	2.2 GHz	Units
Small Signal Gain	19	19	18	dB
Adjacent Channel Power @ $P_{OUT} = 3.2\text{ W}$	-37	-38	-39	dBc
Drain Efficiency @ $P_{OUT} = 3.2\text{ W}$	35	35	33	%
Input Return Loss	5	6	7	dB

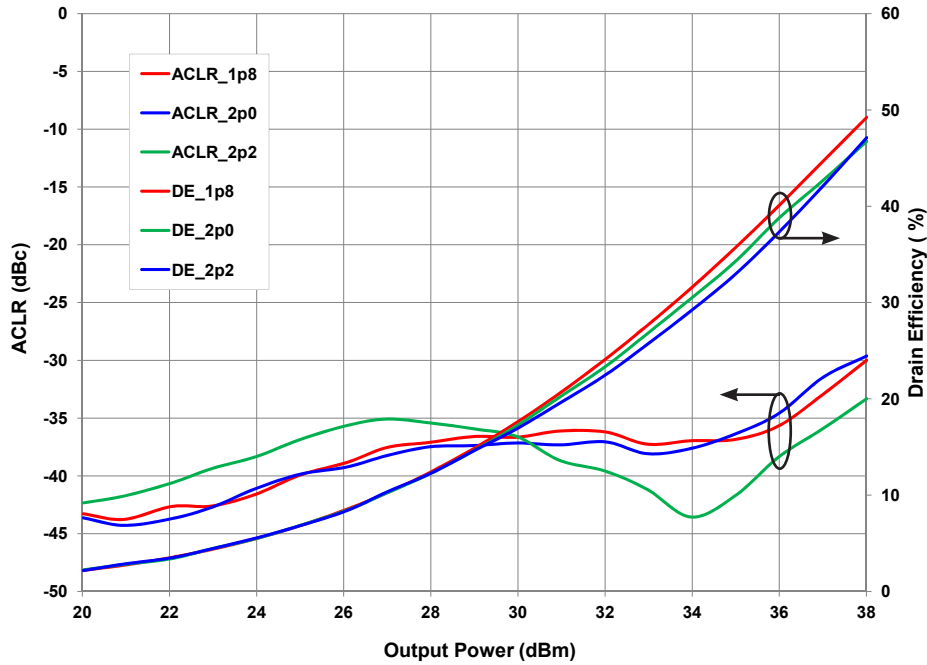
Figure 7. - Small Signal Gain and Return Losses vs Frequency

$V_{DD} = 28\text{ V}, I_{DQ} = 0.13\text{ A}$

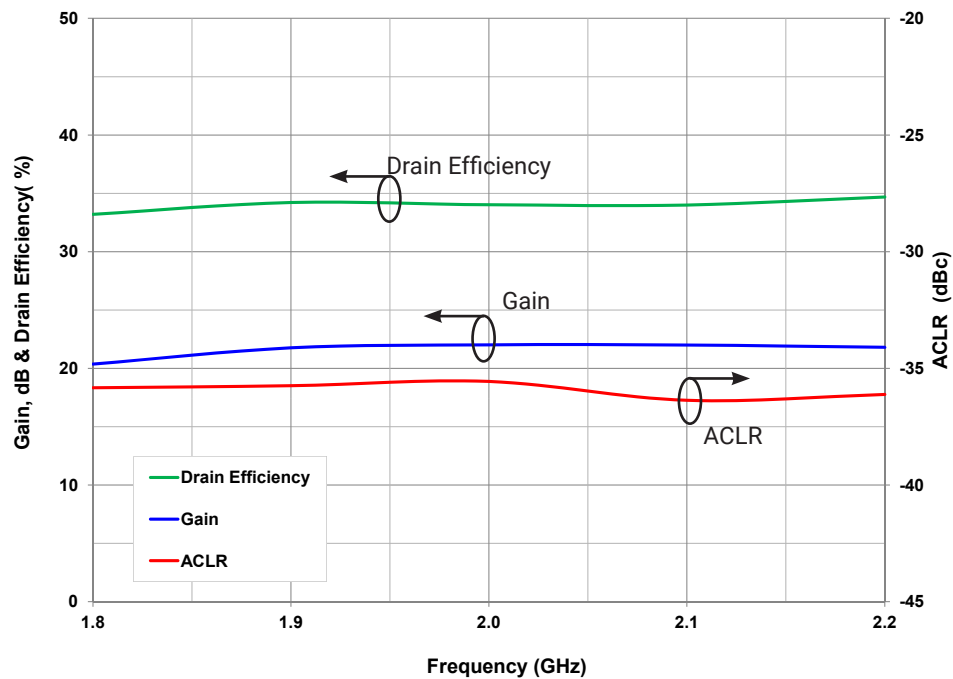


## Typical Performance in Application Circuit CGHV27030S-AMP3

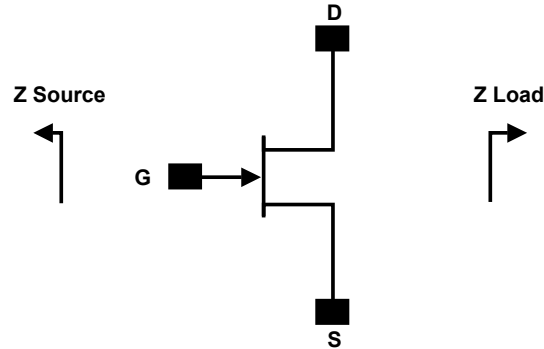
**Figure 8. - Typical Drain Efficiency and ACLR vs. Output Power**  
 $V_{DD} = 28\text{ V}$ ,  $I_{DQ} = 0.13\text{ A}$ , 1c WCDMA, PAR = 7.5 dB



**Figure 9. - Typical Gain, Drain Efficiency and ACLR vs Frequency**  
 $V_{DD} = 28\text{ V}$ ,  $I_{DQ} = 0.13\text{ A}$ ,  $P_{AVE} = 3.2\text{ W}$ , 1c WCDMA, PAR = 7.5 dB



## Source and Load Impedances for Application Circuit CGHV27030S-AMP3



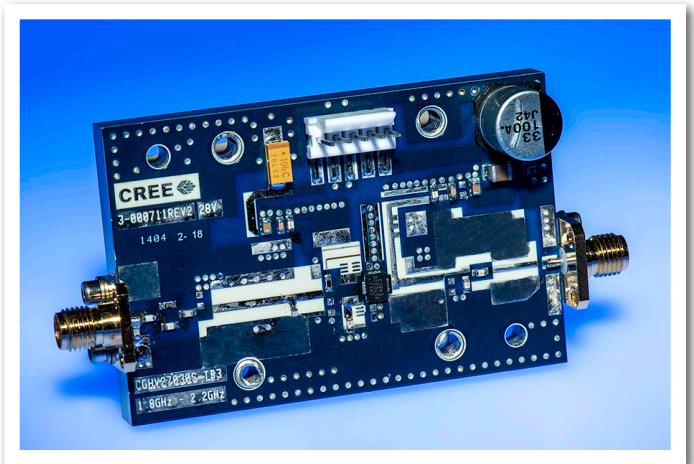
Frequency (MHz)	Z Source	Z Load
1800	6.16 - j3.5	21.9 + j6.5
2000	6.8 - j1.7	21 + j8.4
2200	5.5 - j2.0	20.8 + j11

Note<sup>1</sup>:  $V_{DD} = 28\text{ V}$ ,  $I_{DQ} = 0.13\text{ A}$  in the DFN package.  
 Note<sup>2</sup>: Impedances are extracted from the CGHV27030S-AMP3 application circuit and are not source and load pull data derived from the transistor

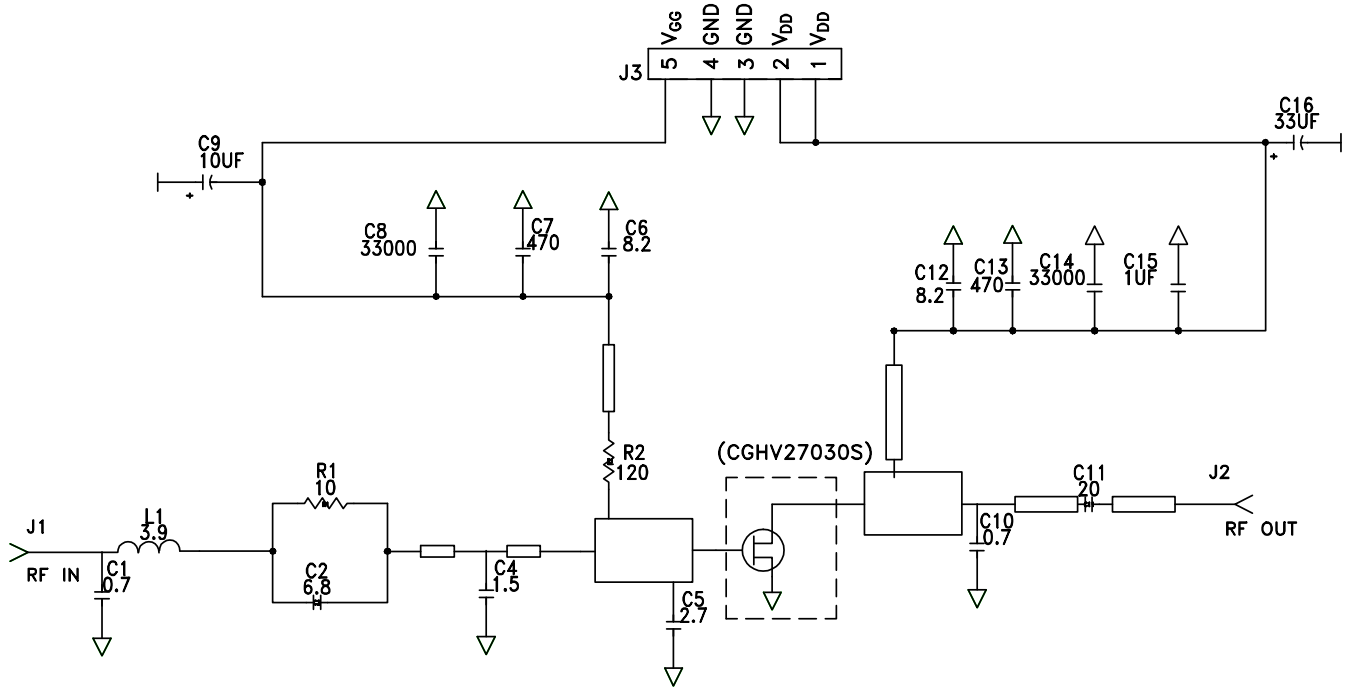
## CGHV27030S-AMP3 Bill of Materials

Designator	Description	Qty
R1	RES, 10, OHM, +/-1%, 1/16W, 0603	1
R2	RES, 120, OHM, +/-1%, 1/16W, 0603	1
L1	IND, 3.9 nH, +/-5%, 0603, JOHANSON	1
C1	CAP, 0.7 pF, +/-0.1 pF, 0603, ATC	1
C2	CAP, 6.8 pF, +/-5%, 0603, ATC	1
C3	CAP, 47pF, +/-0.1 pF, 0603, ATC	1
C4	CAP, 1.5 pF, +/-0.1 pF, 0603, ATC	1
C5	CAP, 2.7 pF, +/-0.1 pF, 0603, ATC	1
C6, C12	CAP, 8.2 pF, +/-0.25 pF, 0603, ATC	2
C7, C13	CAP, 470 pF, 5%, 100 V, 0603	2
C8, C14	CAP, 33000 pF, 0805, X7R	2
C9	CAP 10 UF 16 V TANTALUM	1
C10	CAP, 0.7 pF, +/-0.05 pF, 0603, ATC	1
C11	CAP, 20 pF, +/-5%, 0603, ATC	1
C15	CAP, 1.0 UF, 100V, 10%, X7R, 1210	1
C16	CAP, 33 UF, 20%, G CASE	1
J1, J2	CONN, SMA, PANEL MOUNT JACK, FLANGE, 4-HOLE, BLUNT POST	2
	PCB, RO4350, 0.020" THK	1
	BASEPLATE, CGH35015, 2.60 X 1.7	1
J3	HEADER RT>PLZ .1CEN LK 5POS	1
	2-56 SOC HD SCREW 1/4 SS	4
	#2 SPLIT LOCKWASHER SS	4
Q1	CGHV27030S, QFN	1

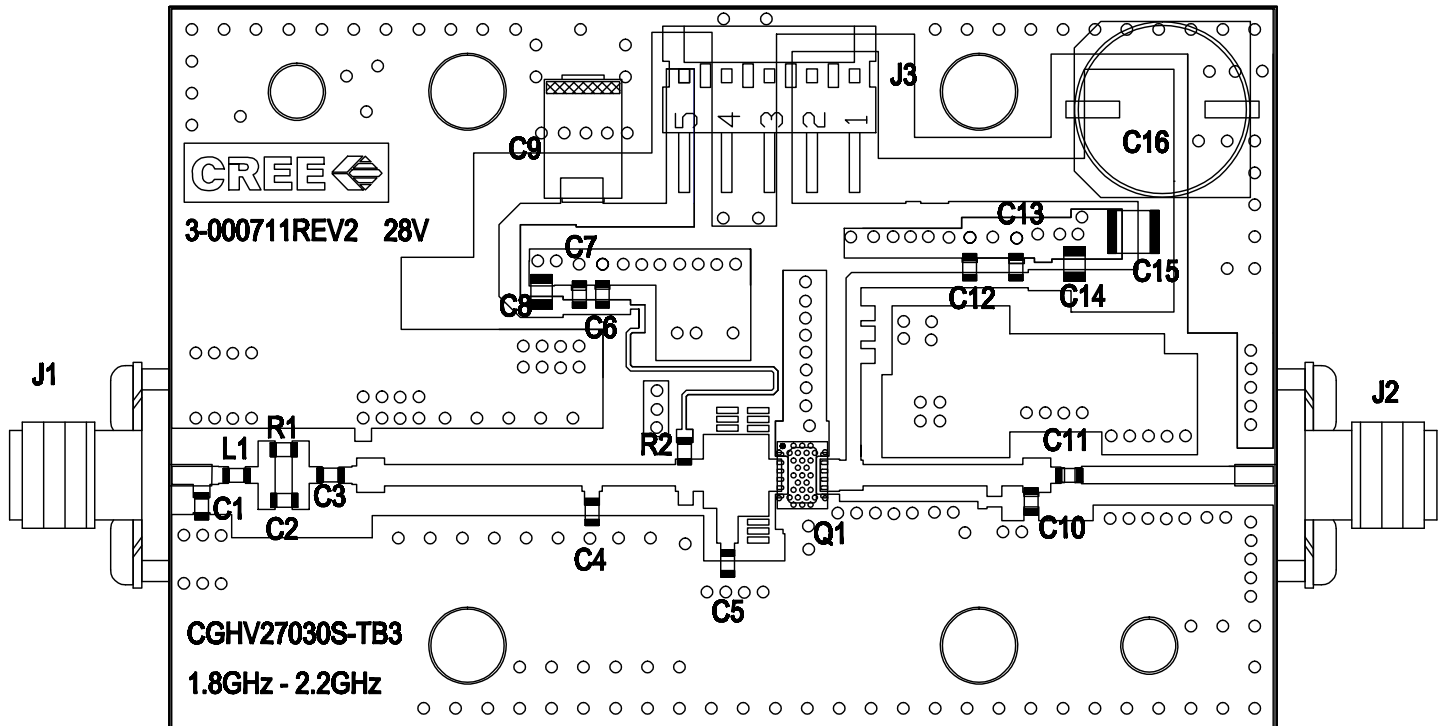
## CGHV27030S-AMP3 Application Circuit



## CGHV27030S-AMP3 Application Circuit Schematic, 28 V



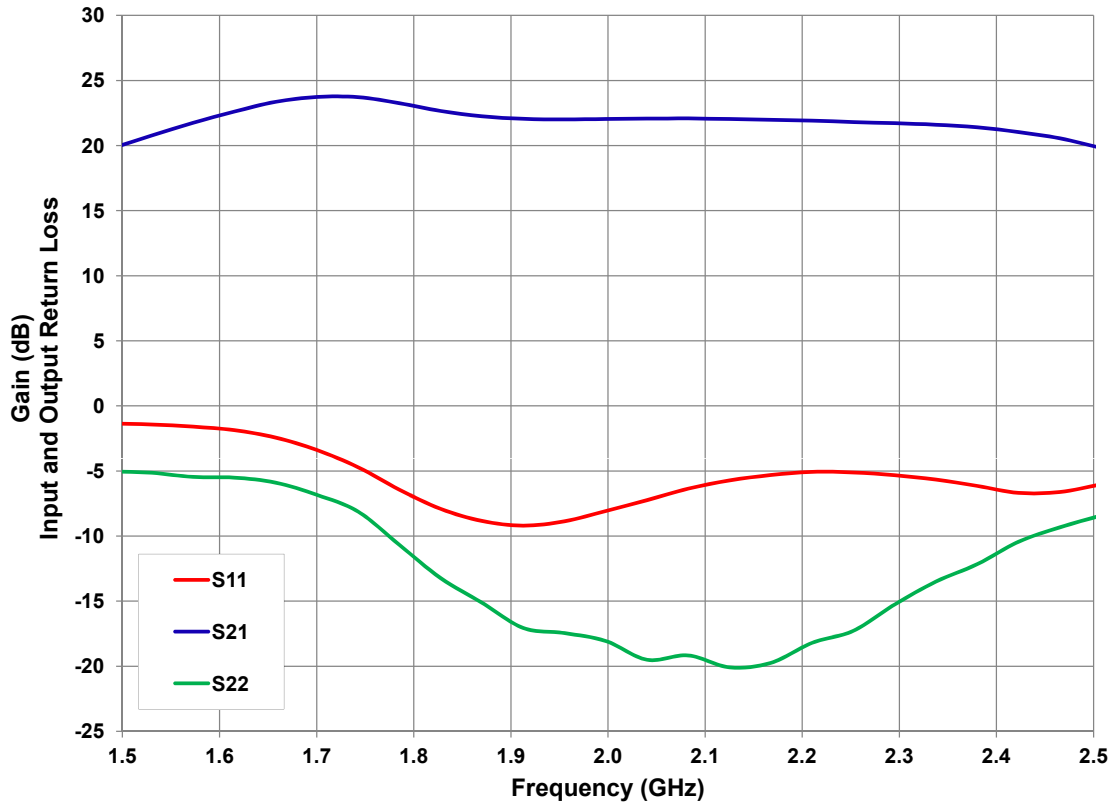
## CGHV27030S-AMP3 Application Circuit Outline, 28 V



### Electrical Characteristics When Tested in CGHV27030S-AMP4, 50 V, 1.8 - 2.2 GHz

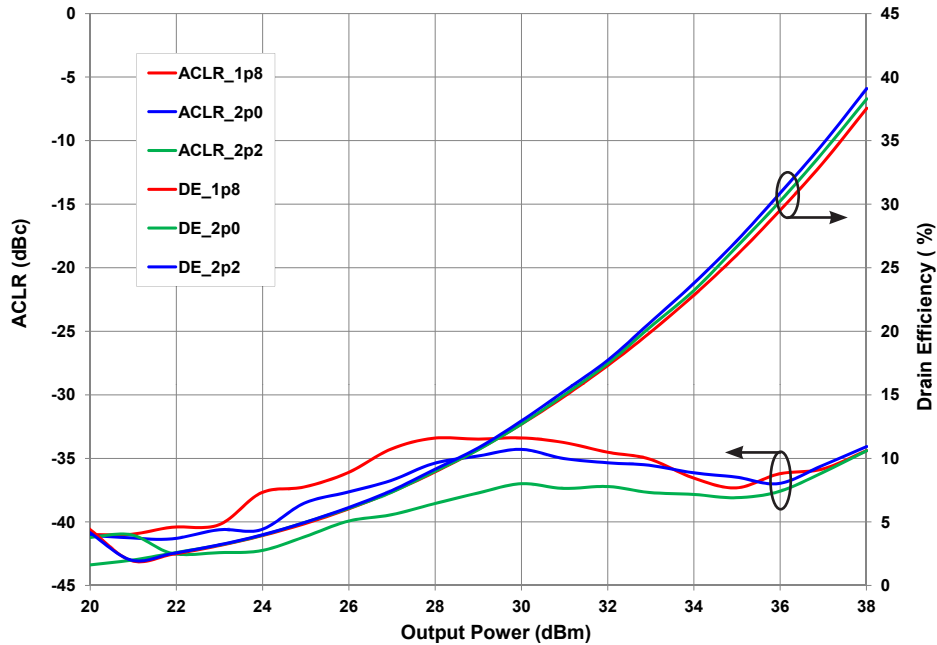
Parameter	1.8 GHz	2.0 GHz	2.2 GHz	Units
Small Signal Gain	22	22	21	dB
Adjacent Channel Power @ $P_{OUT} = 5\text{ W}$	-39	-38	-37	dBc
Drain Efficiency @ $P_{OUT} = 5\text{ W}$	31	32	33	%
Input Return Loss	5	7	6	dB

**Figure 10. - Small Signal Gain and Return Losses vs Frequency**  
 $V_{DD} = 50\text{ V}, I_{DQ} = 0.13\text{ A}$

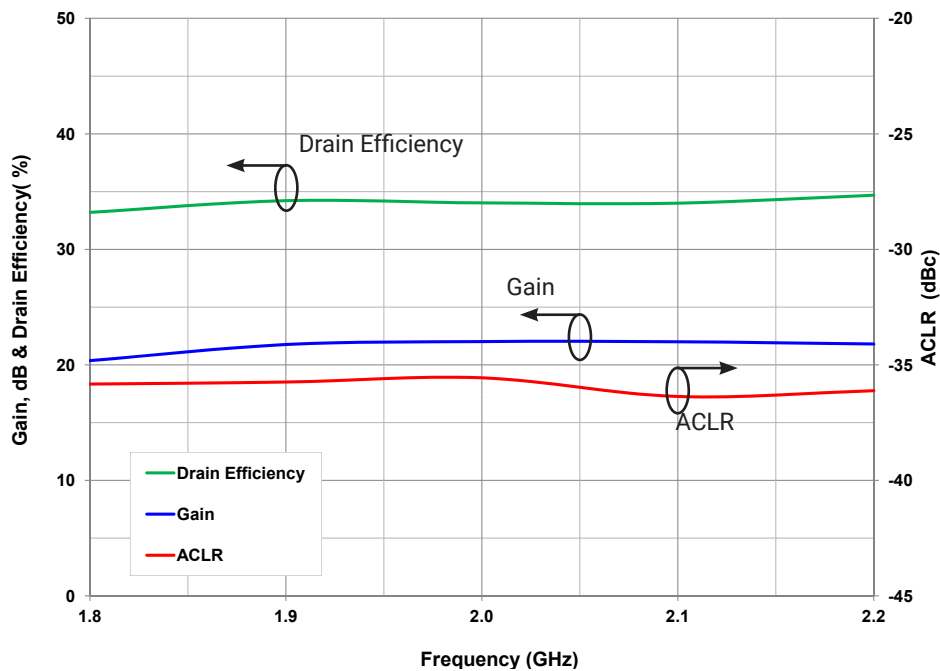


## Typical Performance in Application Circuit CGHV27030S-AMP4

**Figure 11. - Typical Drain Efficiency and ACLR vs. Output Power**  
 $V_{DD} = 50\text{ V}$ ,  $I_{DQ} = 0.13\text{ A}$ , 1c WCDMA, PAR = 7.5 dB

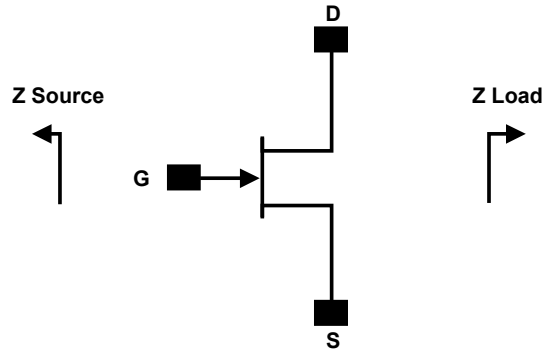


**Figure 12. - Typical Gain, Drain Efficiency and ACLR vs Frequency**  
 $V_{DD} = 50\text{ V}$ ,  $I_{DQ} = 0.13\text{ A}$ ,  $P_{AVE} = 5\text{ W}$ , 1c WCDMA, PAR = 7.5 dB





## Source and Load Impedances for Application Circuit CGHV27030S-AMP4



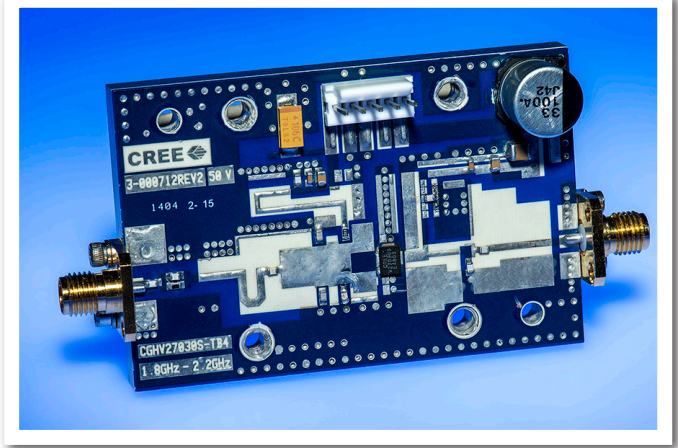
Frequency (MHz)	Z Source	Z Load
1800	5.0 - j3.3	20.0 + j18.6
2000	6.4 - j3.3	17.8 + j19.1
2200	4.0 - j2.7	16.2 + j20.8

Note<sup>1</sup>:  $V_{DD} = 50\text{ V}$ ,  $I_{DQ} = 0.13\text{ A}$  in the DFN package.  
 Note<sup>2</sup>: Impedances are extracted from the CGHV27030S-AMP4 application circuit and are not source and load pull data derived from the transistor

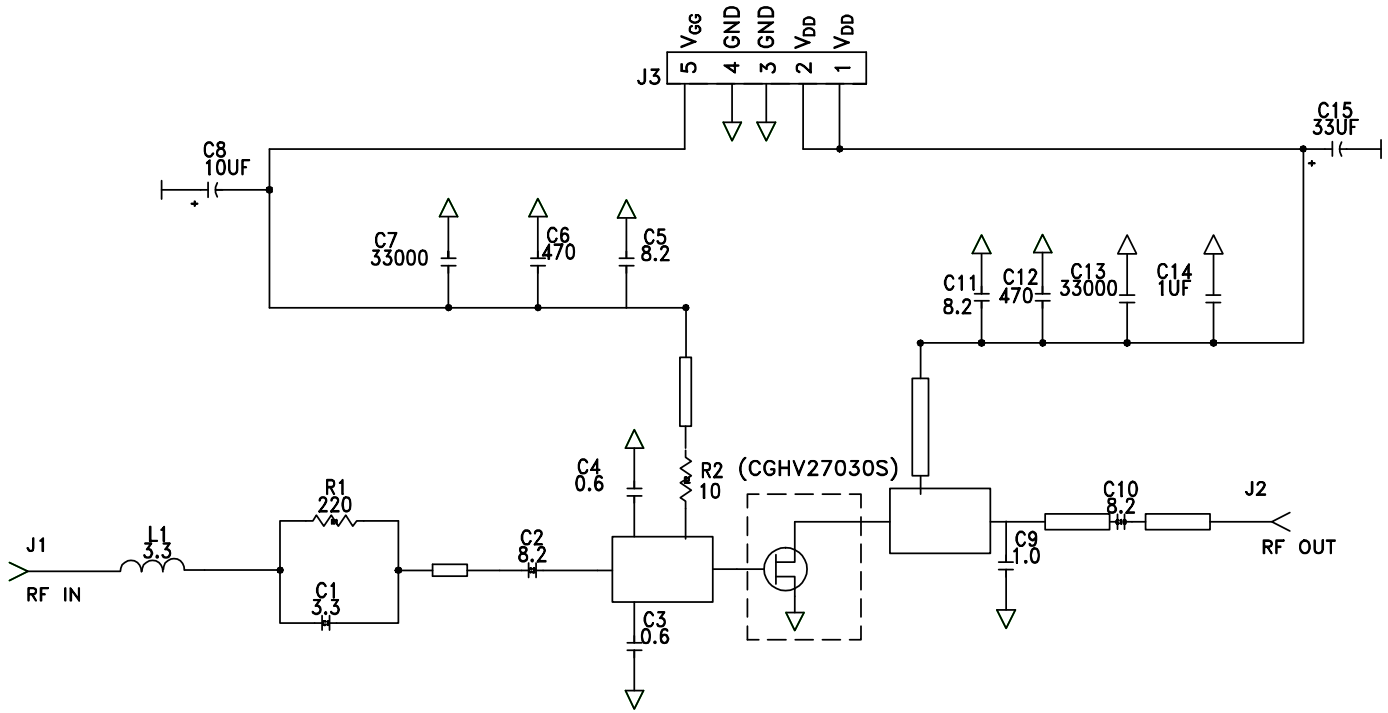
### CGHV27030S-AMP4 Bill of Materials

Designator	Description	Qty
R1	RES, 220, OHM, +/-1%, 1/16W, 0603	1
R2	RES, 10, OHM, +/-1%, 1/16W, 0603	1
L1	IND, 3.3 nH, +/-5%, 0603, JOHANSON	1
C1	CAP, 3.3 pF, +/-0.1 pF, 0603, ATC	1
C2, C5, C10, C11	CAP, 8.2 pF, +/-5%, 0603, ATC	1
C3, C4	CAP, 0.6 pF, +/-0.1 pF, 0603, ATC	2
C6, C12	CAP, 470 pF, 5%, 100V, 0603, X	2
C7, C13	CAP, 33000 pF, 0805, 100V, X7R	2
C8	CAP 10 UF 16 V TANTALUM	1
C9	CAP, 1.0 pF, +/-0.1 pF, 0603, ATC	1
C14	CAP, 1.0 UF, 100V, 10%, X7R, 1210	1
C15	CAP, 33 UF, 20%, G CASE	1
J1, J2	CONN, SMA, PANEL MOUNT JACK, FLANGE, 4-HOLE, BLUNT POST	2
PCB	PCB, RO4350, 0.020" THK	1
J3	HEADER RT>PLZ .1CEN LK 5POS	1
Q1	CGHV27030S, QFN	1

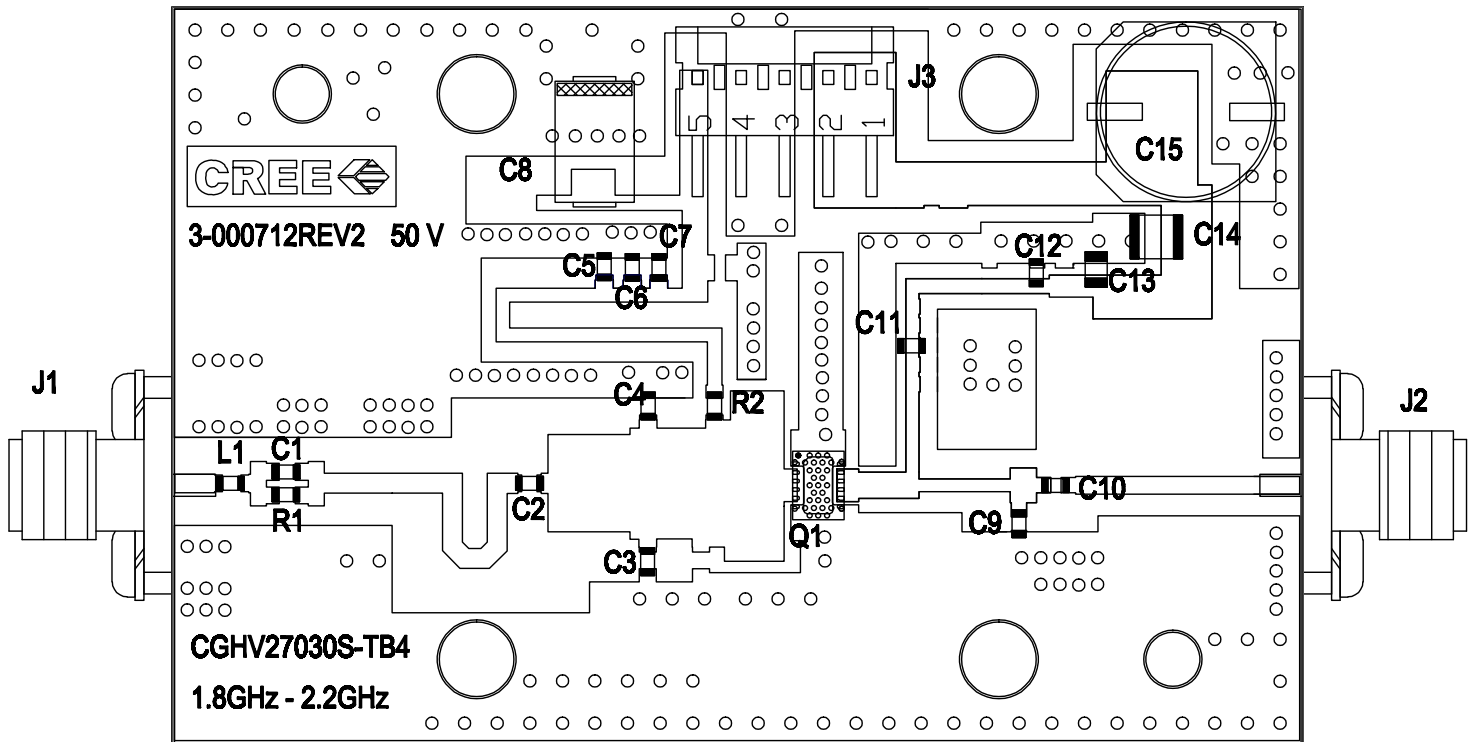
### CGHV27030S-AMP4 Application Circuit



## CGHV27030S-AMP4 Application Circuit Schematic, 50 V



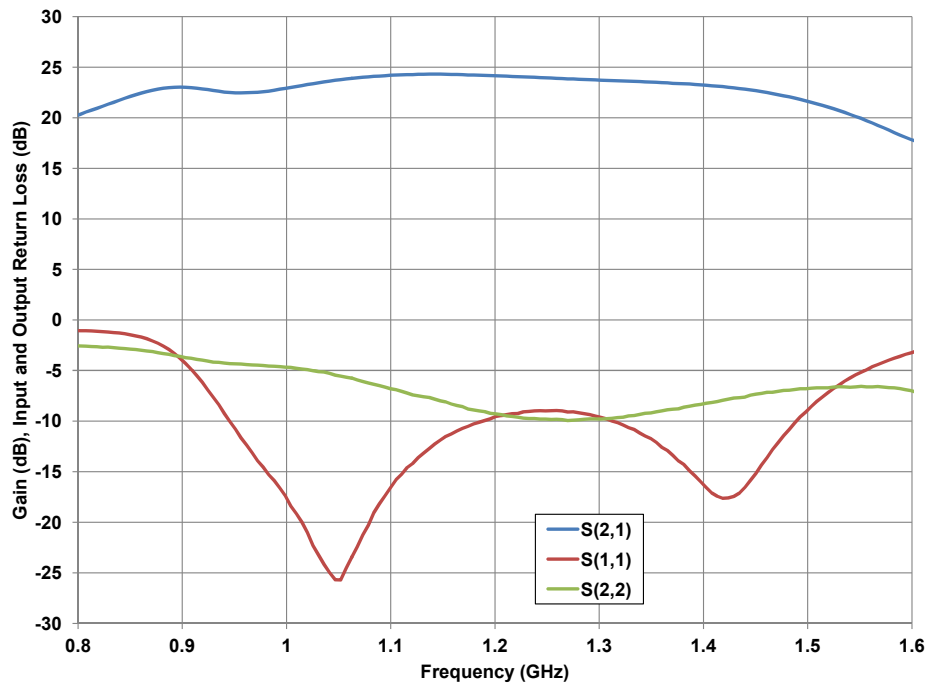
## CGHV27030S-AMP4 Application Circuit Outline, 50 V



### Electrical Characteristics When Tested in CGHV27030S-AMP5, 50 V, 1.2 - 1.4 GHz

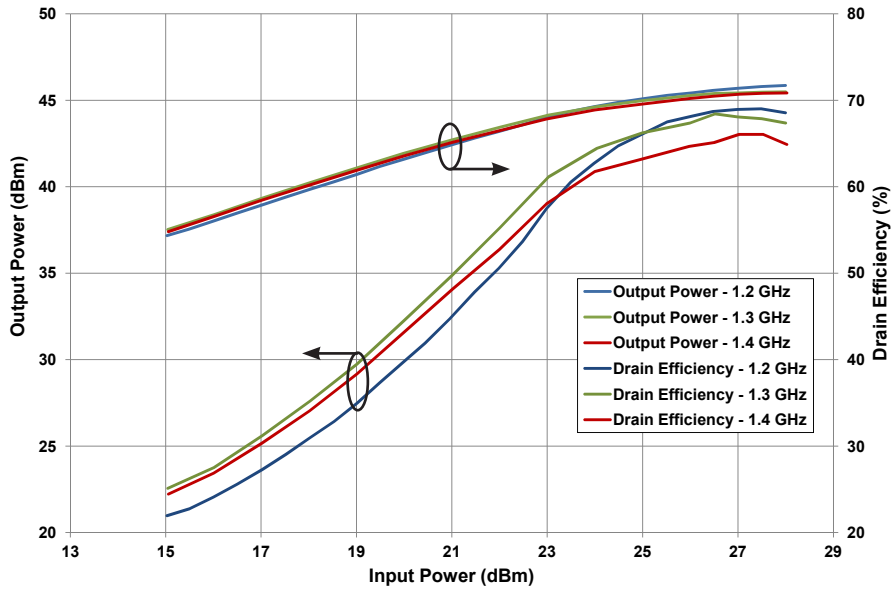
Parameter	1.2 GHz	1.3 GHz	1.4 GHz	Units
Output Power @ $P_{IN} = 27$ dBm	35.5	33.5	32.5	W
Gain @ $P_{IN} = 27$ dBm	18.5	18.25	18.1	dB
Drain Efficiency @ $P_{IN} = 27$ dBm	71	67	65	%

**Figure 13. - Small Signal Gain and Return Losses vs Frequency**  
 $V_{DD} = 50$  V,  $I_{DQ} = 0.125$  A

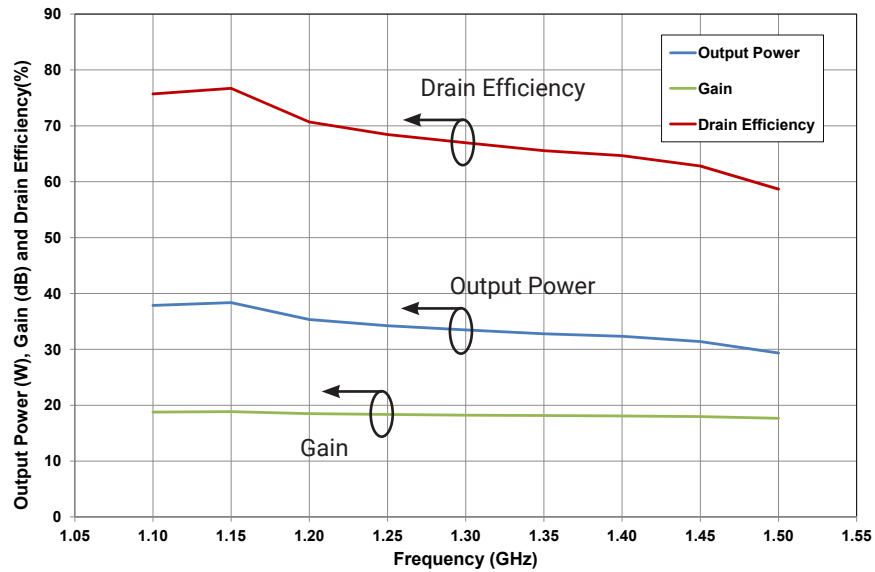


## Typical Performance in Application Circuit CGHV27030S-AMP5

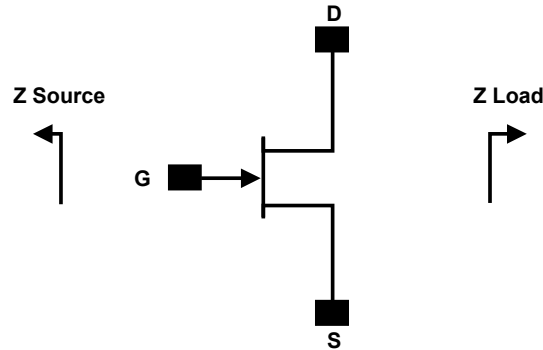
**Figure 14. - Typical Output Power and Drain Efficiency Input Power**  
 $V_{DD} = 50 \text{ V}$ ,  $I_{DQ} = 0.125 \text{ A}$ , Pulse Width = 100 us, Duty Cycle = 10 %



**Figure 15. - Typical Output Power, Gain, and Drain Efficiency vs Frequency**  
 $V_{DD} = 50 \text{ V}$ ,  $I_{DQ} = 0.125 \text{ A}$ ,  $P_{IN} = 27 \text{ dBm}$ , Pulse Width = 100 us, Duty Cycle = 10 %



## Source and Load Impedances for Application Circuit CGHV27030S-AMP5



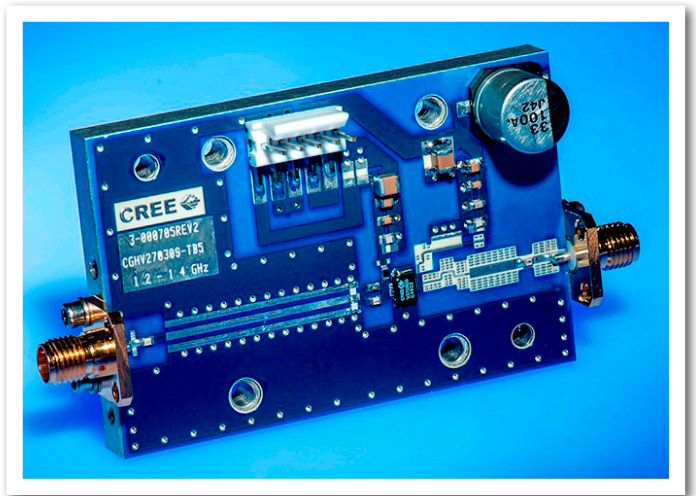
Frequency (MHz)	Z Source	Z Load
1200	8.6 - j5.4	25.4 - j29.2
1300	8.7 - j5.1	27.6 - j30.5
1400	7.4 - j5.2	30.1 - j31.8

Note<sup>1</sup>:  $V_{DD} = 50\text{ V}$ ,  $I_{DQ} = 0.125\text{ A}$  in the DFN package.  
 Note<sup>2</sup>: Impedances are extracted from the CGHV27030S-AMP5 application circuit and are not source and load pull data derived from the transistor

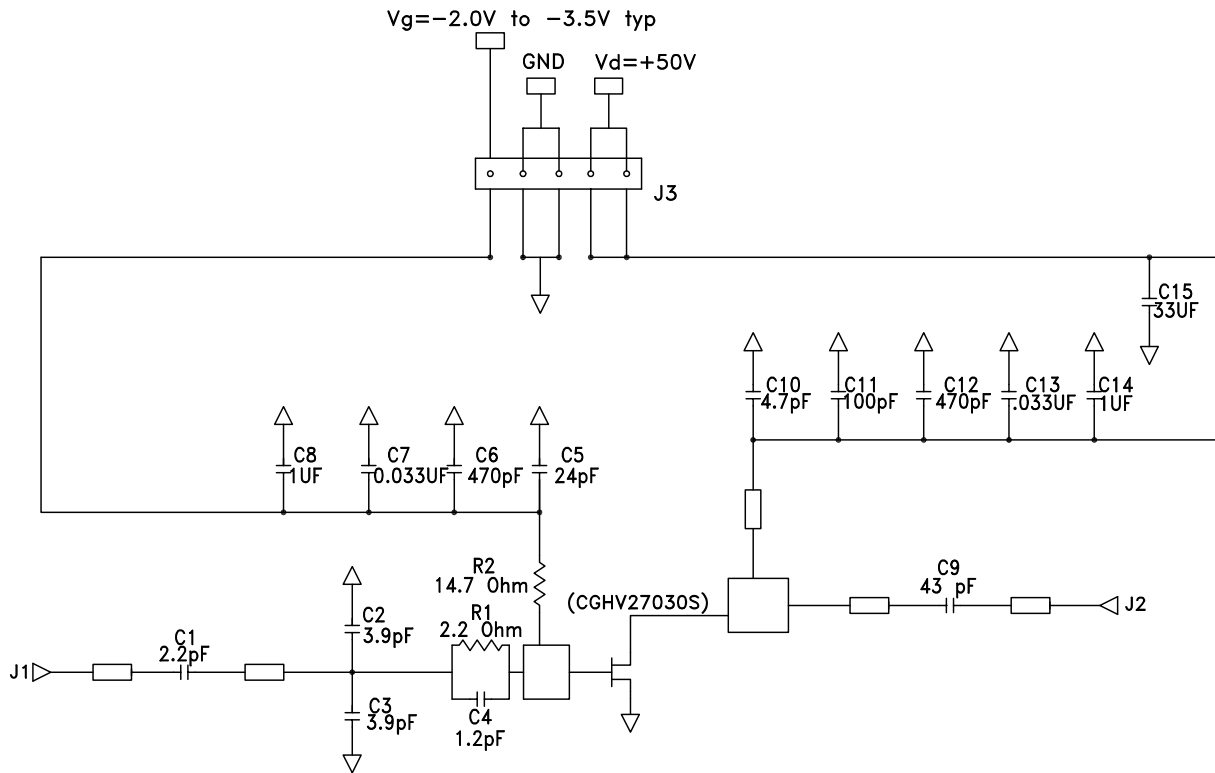
### CGHV27030S-AMP5 Bill of Materials

Designator	Description	Qty
R1	RES, 2.2, OHM, 1/10W 5% 0603 SMD	1
R2	RES, 1/16W, 0603, 1%, 14.7 OHMS	1
C1	CAP, 2.2 pF, +/-0.1 pF, 0603, ATC	1
C2, C3	CAP, 3.9 pF, +/-0.1 pF, 0603, ATC	2
C4	CAP, 1.2 pF, +/-0.1 pF, 0603, ATC	1
C5	CAP, 24 pF, +/-5%, 0603, ATC	1
C6, C12	CAP, 470 pF, 5%, 100V, 0603, X	2
C7, C13	CAP, 33000 pF, 0805, 100V, Z7R	2
C8, C14	CAP, 1.0 uF, 100V, 10%, X7R, 1210	2
C9	CAP, 43 pF, +/-5%, 0603, ATC	1
C10	CAP, 4.7 pF, +/-0.1 pF, 0603, ATC600S	1
C11	CAP, 100.0 pF, +/-5%, 0603, ATC	1
C15	CAP, 33 uF, 20%, G CASE	1
J1, J2	CONN, SMA, PANEL MOUNT JACK, FLANGE, 4-HOLE, BLUNT POST	2
PCB	PCB, R04350, L-BAND, 1.7" X 2.6"	1
J3	HEADER RT>PLZ .1CEN LK 5POS	1
Q1	CGHV27030S, QFN	1

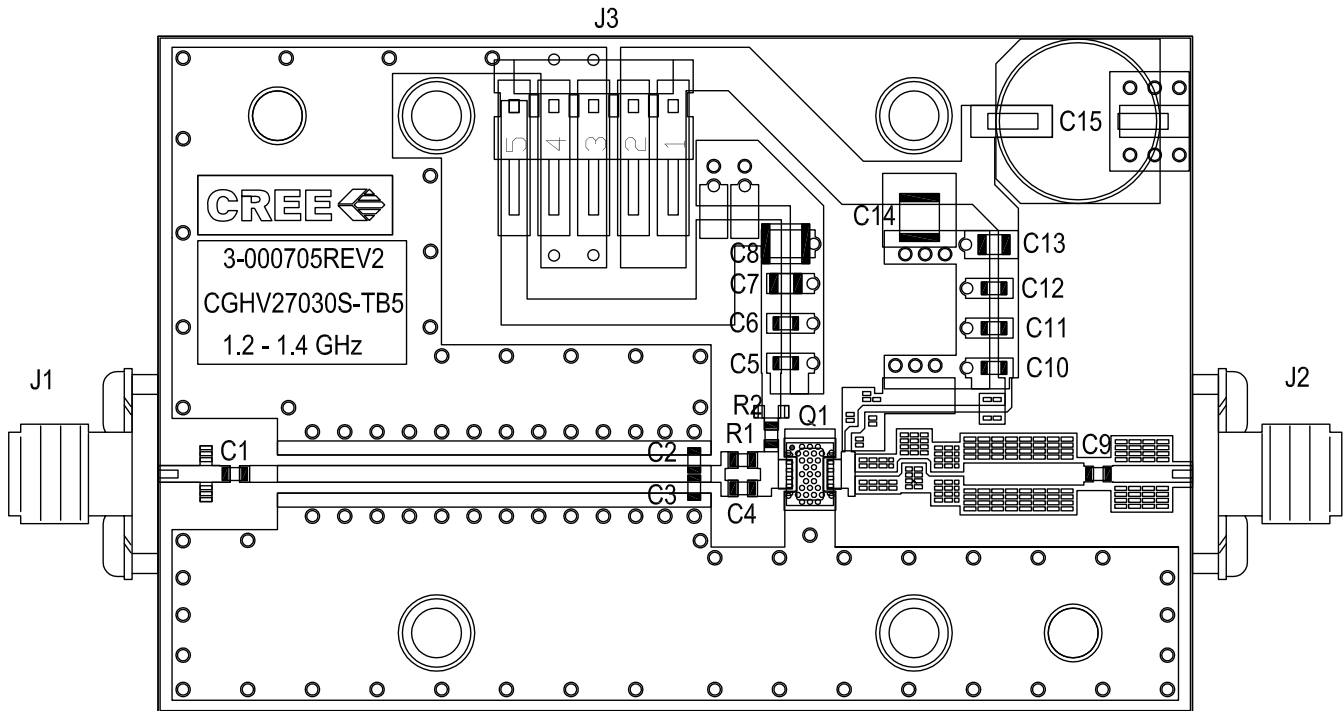
### CGHV27030S-AMP5 Application Circuit



## CGHV27030S-AMP5 Application Circuit Schematic, 50 V

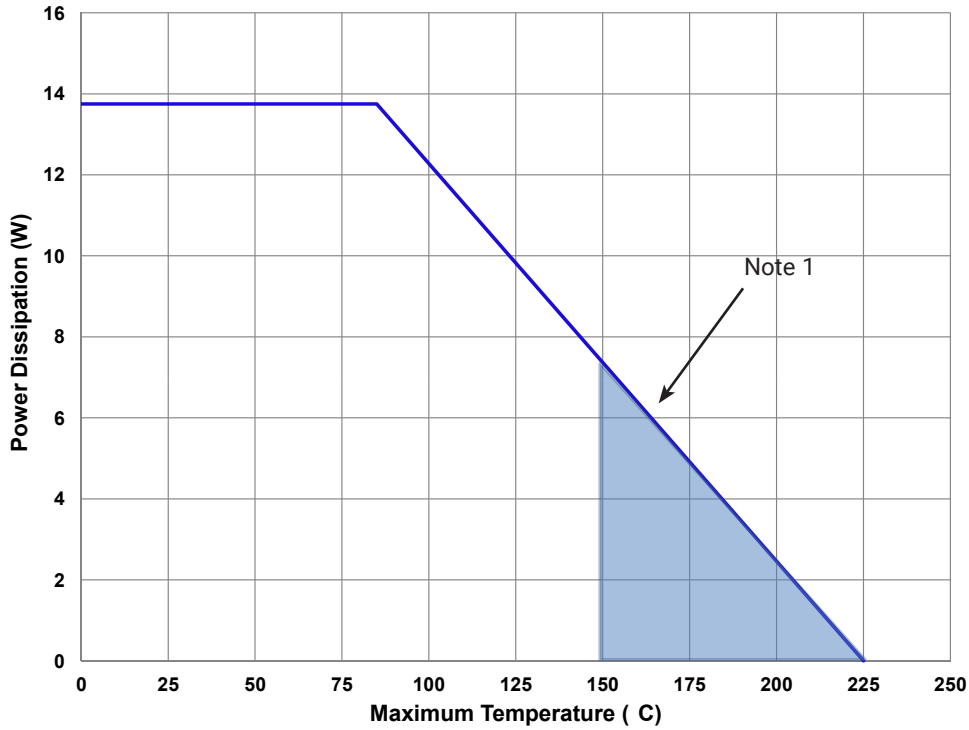


## CGHV27030S-AMP5 Application Circuit Outline, 50 V



## CGHV27030S Power Dissipation De-rating Curve

Figure 16. - CGHV27030S Power Dissipation De-Rating Curve



Note 1. Area exceeds Maximum Case Temperature (See Page 2).

## Electrostatic Discharge (ESD) Classifications

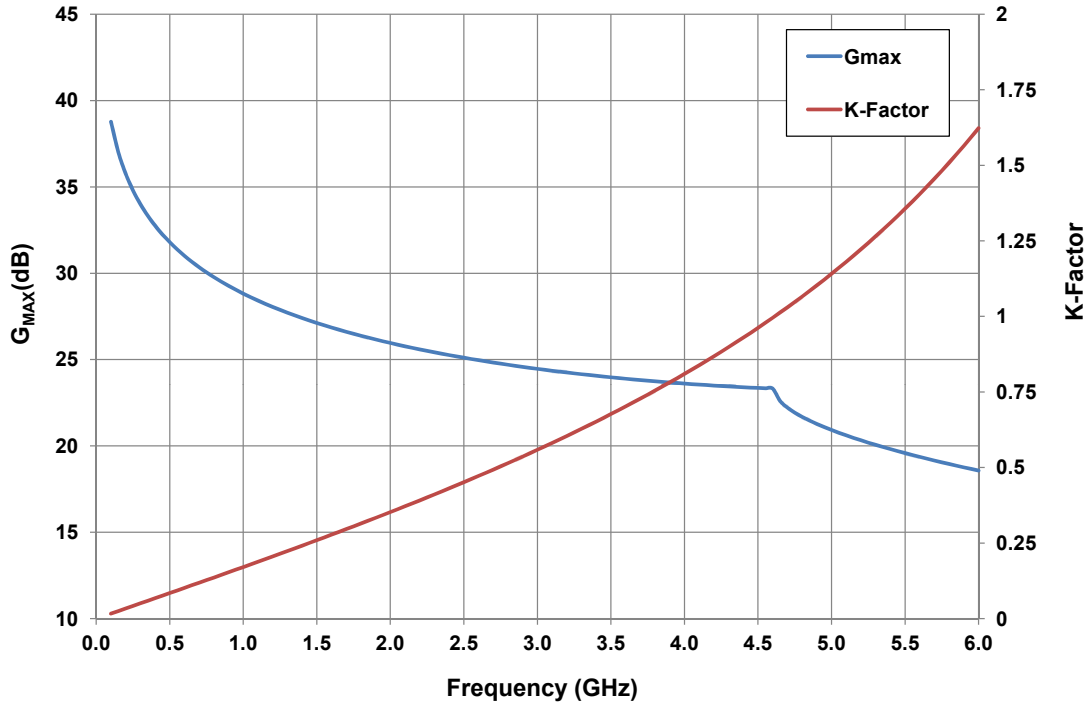
Parameter	Symbol	Class	Test Methodology
Human Body Model	HBM	1A (> 250 V)	JEDEC JESD22 A114-D
Charge Device Model	CDM	2 (125 V to 250 V)	JEDEC JESD22 C101-C

## Moisture Sensitivity Level (MSL) Classification

Parameter	Symbol	Level	Test Methodology
Moisture Sensitivity Level	MSL	3 (168 hours)	IPC/JEDEC J-STD-20

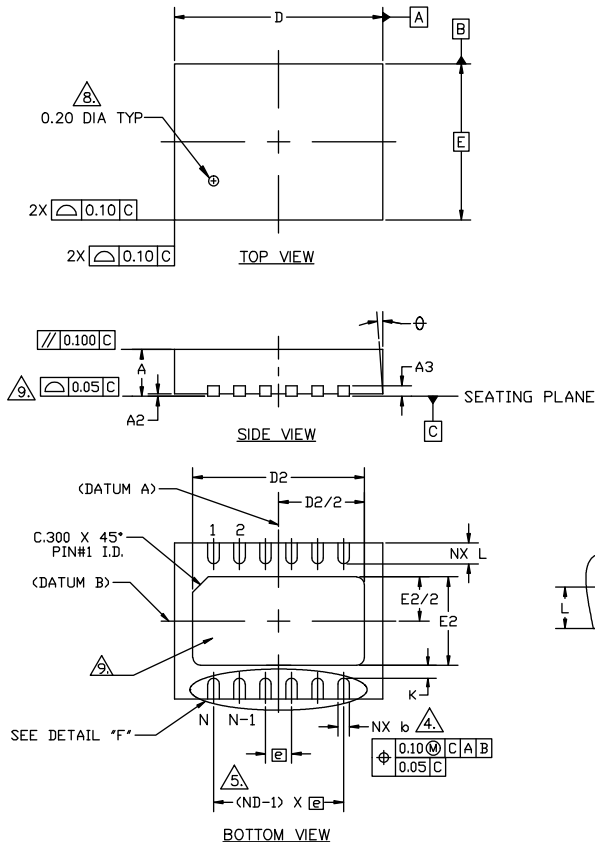
## Typical Performance

**$G_{MAX}$  and K-Factor vs Frequency**  
 $V_{DD} = 50\text{ V}$ ,  $I_{DQ} = 130\text{ mA}$ ,  $T_{case} = 25^{\circ}\text{C}$



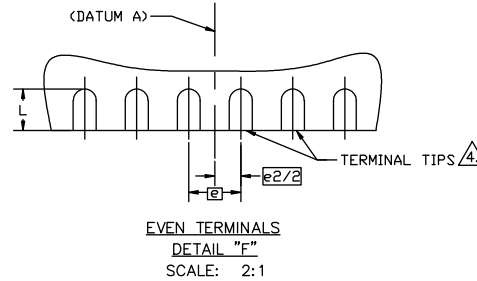


## Product Dimensions CGHV27030S (Package 3 x 4 DFN)



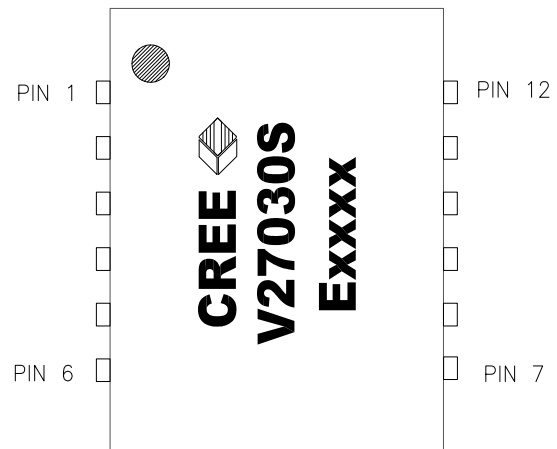
### NOTES :

1. DIMENSIONING AND TOLERANCING CONFORM TO ASME Y14.5M – 1994.
2. ALL DIMENSIONS ARE IN MILLIMETERS,  $\phi$  IS IN DEGREES.
3. N IS THE TOTAL NUMBER OF TERMINALS.
4. DIMENSION b APPLIES TO METALLIZED TERMINAL AND IS MEASURED BETWEEN .15 AND .30mm FROM TERMINAL TIP. IF THE TERMINAL HAS THE OPTIONAL RADIUS ON THE OTHER END OF THE TERMINAL, THE DIMENSION b SHOULD NOT BE MEASURED IN THAT RADIUS AREA.
5. ND REFERS TO THE NUMBER OF TERMINALS ON D SIDE
6. MAXIMUM PACKAGE WARPAGE IS .05 mm.
7. MAXIMUM ALLOWABLE BURRS IS .076 mm IN ALL DIRECTIONS.
8. PIN #1 ID ON TOP WILL BE LASER MARKED.
9. UNILATERAL COPLANARITY ZONE APPLIES TO THE EXPOSED HEAT SINK SLUG AS WELL AS THE TERMINALS.



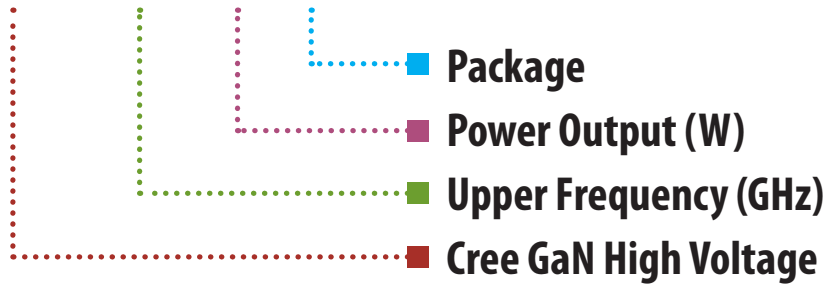
COMMON DIMENSIONS				N <sub>OT E</sub>
	MIN.	NOM.	MAX.	
A	0.80	0.85	0.90	
A1	0.00	0.02	0.05	
A3	0.203 REF.			
$\phi$	0	—	12	2
D	4.00 BSC			
E	3.00 BSC			
$\square$	0.50 BSC			
N	6			
ND	12			3
L	0.35	0.40	0.45	
b	0.17	0.22	0.27	
D2	3.20	3.30	3.40	
E2	1.60	1.7	1.80	
K	0.20	—	—	

Pin	Input/Output
1	GND
2	NC
3	RF IN
4	RF IN
5	NC
6	GND
7	GND
8	NC
9	RF OUT
10	RF OUT
11	NC
12	GND



Note: Leadframe finish for 3x4 DFN package is Nickel/Palladium/Gold. Gold is the outer layer.

### CGHV27030S



Parameter	Value	Units
Upper Frequency <sup>1</sup>	2.7	GHz
Power Output	30	W
Package	Surface Mount	-

**Table 1.**

**Note<sup>1</sup>:** Alpha characters used in frequency code indicate a value greater than 9.9 GHz. See Table 2 for value.

Character Code	Code Value
A	0
B	1
C	2
D	3
E	4
F	5
G	6
H	7
J	8
K	9
Examples:	1A = 10.0 GHz 2H = 27.0 GHz

**Table 2.**

## Product Ordering Information

Order Number	Description	Unit of Measure	Image
CGHV27030S	GaN HEMT	Each	
CGHV27030S-AMP1	Test board without GaN HEMT, 50 V 2.5-2.7 GHz	Each	
CGHV27030S-AMP2	Test board with GaN HEMT installed 28 V 2.5-2.7 GHz	Each	
CGHV27030S-AMP3	Test board with GaN HEMT installed 28 V 1.8-2.2 GHz	Each	
CGHV27030S-AMP4	Test board with GaN HEMT installed 50 V 1.8-2.2 GHz	Each	
CGHV27030S-AMP5	Test board with GaN HEMT installed 50 V 1.2-1.4 GHz	Each	
CGHV27030S-TR	Delivered in Tape and Reel	250 parts / reel	



## Disclaimer

Specifications are subject to change without notice. Cree, Inc. believes the information contained within this data sheet to be accurate and reliable. However, no responsibility is assumed by Cree for any infringement of patents or other rights of third parties which may result from its use. No license is granted by implication or otherwise under any patent or patent rights of Cree. Cree makes no warranty, representation or guarantee regarding the suitability of its products for any particular purpose. "Typical" parameters are the average values expected by Cree in large quantities and are provided for information purposes only. These values can and do vary in different applications and actual performance can vary over time. All operating parameters should be validated by customer's technical experts for each application. Cree products are not designed, intended or authorized for use as components in applications intended for surgical implant into the body or to support or sustain life, in applications in which the failure of the Cree product could result in personal injury or death or in applications for planning, construction, maintenance or direct operation of a nuclear facility.

For more information, please contact:

Cree, Inc.  
4600 Silicon Drive  
Durham, North Carolina, USA 27703  
[www.cree.com/rf](http://www.cree.com/rf)

Sarah Miller  
Marketing  
Cree, RF Components  
1.919.407.5302

Ryan Baker  
Marketing & Sales  
Cree, RF Components  
1.919.407.7816

Tom Dekker  
Sales Director  
Cree, RF Components  
1.919.313.5639

## Данный компонент на территории Российской Федерации

### Вы можете приобрести в компании MosChip.

Для оперативного оформления запроса Вам необходимо перейти по данной ссылке:

<http://moschip.ru/get-element>

Вы можете разместить у нас заказ для любого Вашего проекта, будь то серийное производство или разработка единичного прибора.

В нашем ассортименте представлены ведущие мировые производители активных и пассивных электронных компонентов.

Нашей специализацией является поставка электронной компонентной базы двойного назначения, продукции таких производителей как XILINX, Intel (ex.ALTERA), Vicor, Microchip, Texas Instruments, Analog Devices, Mini-Circuits, Amphenol, Glenair.

Сотрудничество с глобальными дистрибьюторами электронных компонентов, предоставляет возможность заказывать и получать с международных складов практически любой перечень компонентов в оптимальные для Вас сроки.

На всех этапах разработки и производства наши партнеры могут получить квалифицированную поддержку опытных инженеров.

Система менеджмента качества компании отвечает требованиям в соответствии с ГОСТ Р ИСО 9001, ГОСТ РВ 0015-002 и ЭС РД 009

### Офис по работе с юридическими лицами:

105318, г.Москва, ул.Щербаковская д.3, офис 1107, 1118, ДЦ «Щербаковский»

Телефон: +7 495 668-12-70 (многоканальный)

Факс: +7 495 668-12-70 (доб.304)

E-mail: [info@moschip.ru](mailto:info@moschip.ru)

Skype отдела продаж:

moschip.ru

moschip.ru\_4

moschip.ru\_6

moschip.ru\_9