

# Multistage Series MS4,115,14,15 Thermoelectric Modules

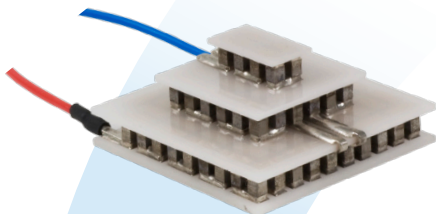

The MS Series of thermoelectric modules (TEMs) are designed to reach cool down temperatures that are not achievable with single stage TEMs.

This product line is available in numerous heat pumping capacities, geometric shapes and temperature differentials. Assembled with Bismuth Telluride semiconductor material and thermally conductive Aluminum Oxide ceramics, the MS Series is designed for higher current and lower heat-pumping applications.

## FEATURES

- High temperature differential
- Precise temperature control
- Reliable solid state operation
- Environmentally friendly
- DC operation
- RoHS compliant

## APPLICATIONS

- CCD cameras
- Electron microscope
- Calibration equipment
- Photonics laser systems
- Gas analyzers
- infrared (IR) Sensors
- Guidance Systems

## PERFORMANCE SPECIFICATIONS

Hot Side Temperature (°C)	25
Qmax (Watts)	2.7
Delta Tmax (°C)	122
I <sub>max</sub> (Amps)	3.5
V <sub>max</sub> (Volts)	7.5

SUFFIX	THICKNESS (PRIOR TO TINNING)	FLATNESS & PARALLELISM	HOT FACE	COLD FACE	LEAD LENGTH
00	0.551" ± 0.008"	0.001" / 0.004"	Metallized	Metallized	7.87"
11	0.543" ± 0.008"	0.001" / 0.002"	Lapped	Lapped	7.87"
22	0.551" ± 0.008"	0.001" / 0.004"	Pre-tinned	Pre-tinned	7.87"

## SEALING OPTION

SUFFIX	SEALANT	COLOR	TEMP RANGE	DESCRIPTION
RT	RTV	White	-60 to 204 °C	Non-corrosive, silicone adhesive sealant
EP	Epoxy	Black	-55 to 150 °C	Low density syntactic foam epoxy encapsulant

## global solutions: local support™

Americas: +1 888.246.9050

Europe: +46.31.420530

Asia: +86.755.2714.1166

clv.customerpos@lairdtech.com

www.lairdtech.com

# Multistage Series MS4,115,14,15 Thermoelectric Modules

Performance Curves at  $T_h = 25^\circ\text{C}$

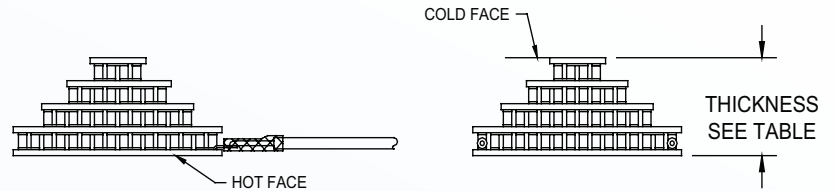
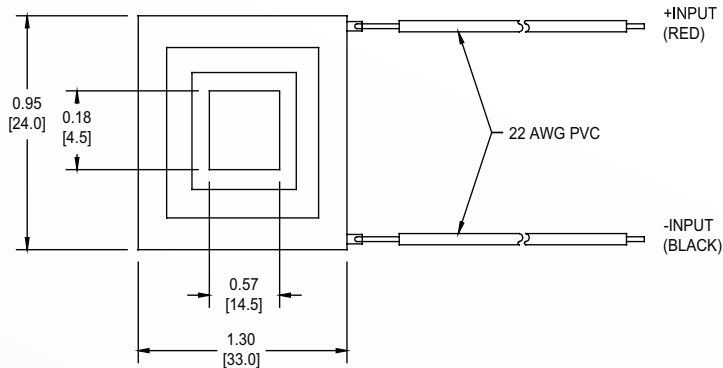
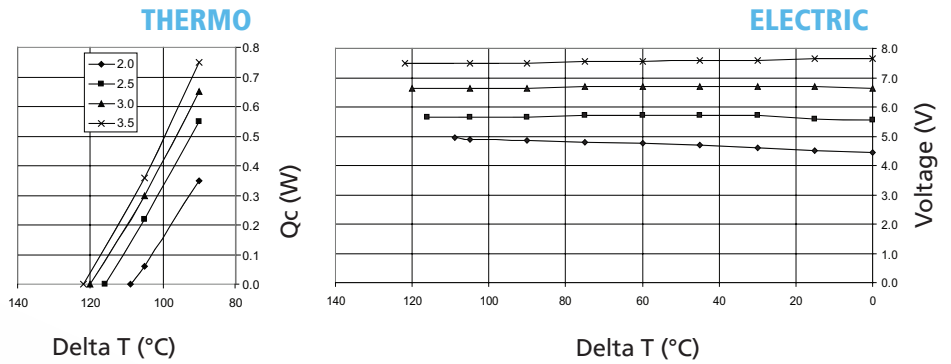

Ceramic Material: **Aluminum Nitride Ceramics**  
 Solder Construction: 138°C, Bismuth Tin (BiSn)

### OPERATING TIPS

- Max Operating Temperature: 80°C
- Do not exceed  $I_{max}$  or  $V_{max}$  when operating module
- Reference assembly guidelines for recommended installation
- Solder tinning also available on metallized ceramics

THR-DS-MS4,115,14,15 0609

Any information furnished by Laird Technologies, Inc. and its agents is believed to be accurate and reliable. Responsibility for the use and application of Laird Technologies materials rests with the end user, since Laird Technologies and its agents cannot be aware of all potential uses. Laird Technologies makes no warranties as to the fitness, merchantability or suitability of any Laird Technologies materials or products for any specific or general uses. Laird Technologies shall not be liable for incidental or consequential damages of any kind. All Laird Technologies products are sold pursuant to the Laird Technologies' Terms and Conditions of sale in effect from time to time, a copy of which will be furnished upon request. © Copyright 2009 Laird Technologies, Inc. All Rights Reserved. Laird, Laird Technologies, the Laird Technologies Logo, and other marks are trademarks or registered trademarks of Laird Technologies, Inc. or an affiliate company thereof. Other product or service names may be the property of third parties. Nothing herein provides a license under any Laird Technologies or any third party intellectual property rights.

## Данный компонент на территории Российской Федерации

### Вы можете приобрести в компании MosChip.

Для оперативного оформления запроса Вам необходимо перейти по данной ссылке:

<http://moschip.ru/get-element>

Вы можете разместить у нас заказ для любого Вашего проекта, будь то серийное производство или разработка единичного прибора.

В нашем ассортименте представлены ведущие мировые производители активных и пассивных электронных компонентов.

Нашей специализацией является поставка электронной компонентной базы двойного назначения, продукции таких производителей как XILINX, Intel (ex.ALTERA), Vicor, Microchip, Texas Instruments, Analog Devices, Mini-Circuits, Amphenol, Glenair.

Сотрудничество с глобальными дистрибьюторами электронных компонентов, предоставляет возможность заказывать и получать с международных складов практически любой перечень компонентов в оптимальные для Вас сроки.

На всех этапах разработки и производства наши партнеры могут получить квалифицированную поддержку опытных инженеров.

Система менеджмента качества компании отвечает требованиям в соответствии с ГОСТ Р ИСО 9001, ГОСТ РВ 0015-002 и ЭС РД 009

### Офис по работе с юридическими лицами:

105318, г.Москва, ул.Щербаковская д.3, офис 1107, 1118, ДЦ «Щербаковский»

Телефон: +7 495 668-12-70 (многоканальный)

Факс: +7 495 668-12-70 (доб.304)

E-mail: [info@moschip.ru](mailto:info@moschip.ru)

Skype отдела продаж:

moschip.ru

moschip.ru\_4

moschip.ru\_6

moschip.ru\_9