

REV	DESCRIPTION	DATE
D	REVISE PER ECO-13-13-002859	02/18/13

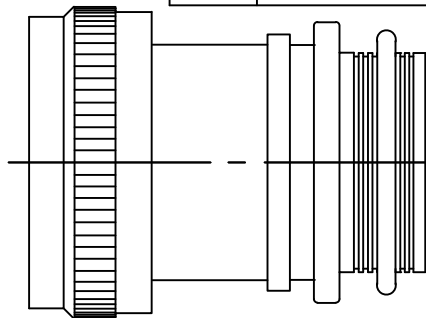

### CODE 76 TINEL-LOCK ADAPTER

**NOTES:**

1. ALL DIMENSIONS ARE IN INCHES [MILLIMETERS].
2. SEE CH00-0250-008 FOR ORDERING INFORMATION, MODIFICATIONS, AND ADDITIONAL DIMENSIONS FOR MODIFICATIONS. MODIFICATIONS INDICATED BY TXR\_\_M OR ANY OF THE FOLLOWING LETTERS AT THE END OF THE PART NUMBER H J L P T S N OR V.
3. SEE DRAWING TR FOR DETAIL ON TINEL-LOCK RING.
4. TEMPERATURE RANGE FOR ALUMINUM ALLOY:  
-65 °C TO +150 °C.
5. ADAPTER TO BE PERMANENTLY MARKED WITH ASSEMBLY PN LESS RING DESIGNATOR (EG: TXR76AB00-1208) AND CODE IDENT. NO. (06090).
6. CONSULT FACTORY FOR OPTIONAL ENTRIES, MATERIALS, MODIFICATIONS, FINISHES AND BRAID DESIGNATORS.
7. INTERNAL EDGES SHALL BE ROUNDED.
8. FOR LARGER ENTRY SIZES, A 2 PIECE ADAPTER (TYPE II) IS SUPPLIED.
9. THIS PRODUCT IS DESIGNED TO TERMINATE A BRAIDED CABLE SHIELD AND A HEAT SHRINKABLE LIPPED BOOT TO A CONNECTOR.
10. RINGS SHALL BEAR NO MARKING.
11. ADAPTER MATES WITH BS 9522, N0001 PATT 603  
BS 9522, F0017 PATT 105.

(C) 2008–2013 Tyco Electronics Corporation. All Rights Reserved

Raychem Adapters  
CUSTOMER DRAWING

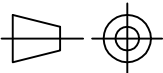
UNLESS OTHERWISE SPECIFIED DIMENSIONS ARE INCHES. METRIC DIMENSIONS ARE IN BRACKETS.	DRAWN A. BUI	DATE 08DEC08	 TE Connectivity	
	MATERIAL		TITLE  TINEL-LOCK™ ADAPTER	
DECIMAL TOLERANCES .XXX ± - [- mm] .XX ± - [- mm] .X ± - [- mm]	FINISH		SIZE A	CODE IDENT. NO. 06090
ANGLE TOLERANCE .X ± -	THIRD ANGLE PROJECTION 		DWG. NO. TXR76	REV
CAD FILE TXR76_C	DO NOT SCALE THIS DRAWING		SHEET 1 OF 3 D	

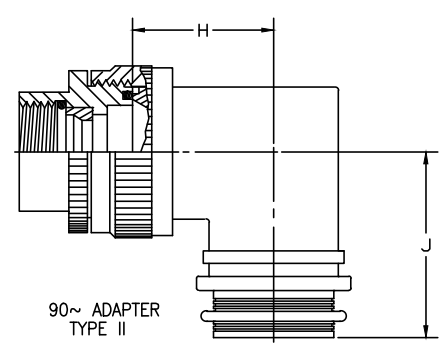
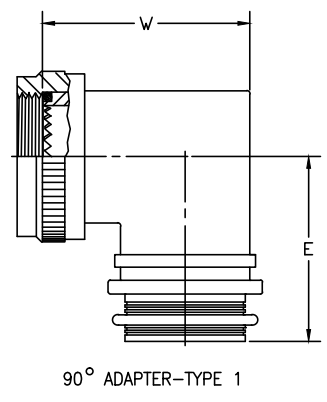
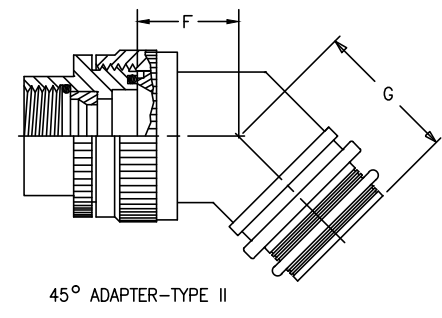
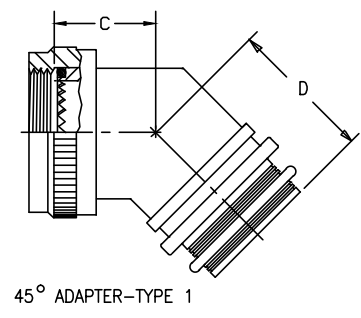
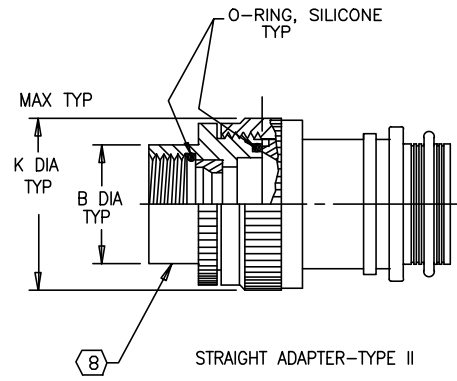
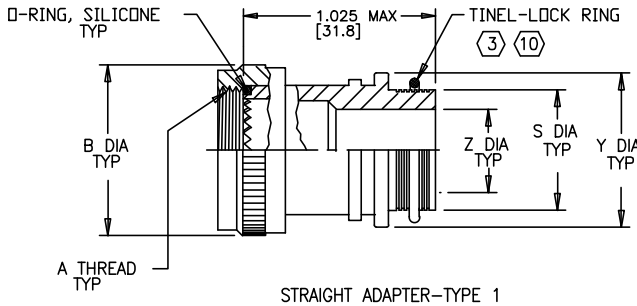

Raychem Adapters  
CUSTOMER DRAWING

DRAWN A. BUI	DATE 08DEC08		SIZE A	CODE IDENT. NO. 06090	DWG. NO. TXR76	REV D
CAD FILE TXR76_D			DO NOT SCALE THIS DRAWING		SHEET 2 OF 3	

TABLE 1								
ORDER NO.	SHELL SIZE ⑪	MAX ENTRY SIZE TYPE I ⑧	A THREAD CLASS 2B	B DIA MAX	C MAX	D MAX	E MAX	W MAX
08	8	04	.438-28 UNEF	.79 [20.1]	.71 [18.0]	.84 [21.3]	1.05 [26.7]	.993 [25.2]
10	10	06	.562-24 UNEF	.91 [23.1]	.74 [18.8]	.87 [22.1]	1.11 [28.2]	1.056 [26.8]
12	12	08	.688-24 UNEF	1.07 [27.2]	.76 [19.3]	.90 [22.9]	1.19 [30.2]	1.181 [30.0]
14	14	10	.812-20 UNEF	1.19 [30.2]	.79 [20.1]	.92 [23.4]	1.25 [31.8]	1.306 [33.2]
16	16	12	.938-20 UNEF	1.32 [33.5]	.82 [20.8]	.95 [24.1]	1.32 [33.5]	1.431 [36.3]
18	18	14	1.062-18 UNEF	1.44 [36.6]	.84 [21.3]	.97 [24.6]	1.38 [35.1]	1.556 [39.5]
20	20	16	1.188-18 UNEF	1.57 [39.9]	.87 [22.1]	1.00 [25.4]	1.44 [36.6]	1.681 [42.7]
22	22	18	1.312-18 UNEF	1.69 [42.9]	.89 [22.6]	1.02 [25.9]	1.50 [38.1]	1.806 [45.9]
24	24	18	1.438-18 UNEF	1.79 [45.5]	.92 [23.4]	1.05 [26.7]	1.55 [39.4]	1.931 [49.0]

TABLE II								
ENTRY SIZE	Z +.010 -.020	S DIA	Y ±.015 [±0.38]	F MAX	G MAX	J MAX	H MAX	K MAX
04	.250 [6.35]	.376 [9.56] .370 [9.39]	.550 [13.97]	NA	NA	NA	NA	NA
05	.312 [7.92]	.438 [11.13] .432 [10.97]	.612 [15.54]	.77 [19.6]	.93 [23.6]	1.16 [29.5]	1.19 [30.2]	.80 [20.3]
06	.375 [9.52]	.501 [12.73] .495 [12.57]	.675 [17.14]	.77 [19.6]	.93 [23.6]	1.16 [29.5]	1.19 [30.2]	.80 [20.3]
07	.437 [11.09]	.563 [14.31] .556 [14.12]	.737 [18.71]	.80 [20.3]	.95 [24.1]	1.22 [31.0]	1.38 [35.1]	.92 [23.4]
08	.500 [12.70]	.626 [15.91] .619 [15.72]	.800 [20.32]	.80 [20.3]	.95 [24.1]	1.22 [31.0]	1.38 [35.1]	.92 [23.4]
10	.625 [15.87]	.752 [19.11] .742 [18.84]	.925 [23.49]	.84 [21.3]	1.00 [25.4]	1.35 [34.3]	1.51 [38.4]	1.18 [30.0]
12	.750 [19.05]	.877 [22.28] .867 [22.02]	1.050 [26.67]	.86 [21.8]	1.01 [25.7]	1.40 [35.6]	1.63 [41.4]	1.35 [34.3]
14	.875 [22.23]	1.002 [25.46] .991 [25.17]	1.175 [29.84]	.88 [22.4]	1.04 [26.4]	1.46 [37.1]	1.78 [45.2]	1.41 [35.8]
16	1.000 [25.40]	1.127 [28.63] 1.116 [28.34]	1.300 [33.02]	.91 [23.1]	1.06 [26.9]	1.53 [38.9]	1.88 [47.8]	1.60 [40.6]
18	1.125 [28.57]	1.252 [31.81] 1.241 [31.52]	1.425 [36.19]	.93 [23.6]	1.09 [27.7]	1.59 [40.4]	2.01 [51.1]	1.66 [42.2]
20	1.250 [31.75]	1.377 [34.98] 1.366 [34.69]	1.550 [39.37]	.98 [24.9]	1.13 [28.7]	1.78 [45.2]	2.13 [54.1]	2.04 [51.8]
22	1.375 [34.93]	1.502 [38.15] 1.488 [37.79]	1.675 [42.55]	1.03 [26.2]	1.38 [35.1]	1.85 [47.0]	2.29 [58.2]	2.23 [56.6]
24	1.500 [38.10]	1.627 [41.33] 1.613 [40.97]	1.800 [45.72]	1.08 [27.4]	1.44 [36.6]	1.92 [48.8]	2.42 [61.5]	2.23 [56.6]

Raychem Adapter  
CUSTOMER DRAWING

DRAWN A. BUI	DATE 08DEC08		SIZE A	CODE IDENT. NO. 06090	DWG. NO. TXR76	REV D
CAD FILE TXR76_D			DO NOT SCALE THIS DRAWING		SHEET 3 OF 3	

## Данный компонент на территории Российской Федерации

### Вы можете приобрести в компании MosChip.

Для оперативного оформления запроса Вам необходимо перейти по данной ссылке:

<http://moschip.ru/get-element>

Вы можете разместить у нас заказ для любого Вашего проекта, будь то серийное производство или разработка единичного прибора.

В нашем ассортименте представлены ведущие мировые производители активных и пассивных электронных компонентов.

Нашей специализацией является поставка электронной компонентной базы двойного назначения, продукции таких производителей как XILINX, Intel (ex.ALTERA), Vicor, Microchip, Texas Instruments, Analog Devices, Mini-Circuits, Amphenol, Glenair.

Сотрудничество с глобальными дистрибьюторами электронных компонентов, предоставляет возможность заказывать и получать с международных складов практически любой перечень компонентов в оптимальные для Вас сроки.

На всех этапах разработки и производства наши партнеры могут получить квалифицированную поддержку опытных инженеров.

Система менеджмента качества компании отвечает требованиям в соответствии с ГОСТ Р ИСО 9001, ГОСТ РВ 0015-002 и ЭС РД 009

### Офис по работе с юридическими лицами:

105318, г.Москва, ул.Щербаковская д.3, офис 1107, 1118, ДЦ «Щербаковский»

Телефон: +7 495 668-12-70 (многоканальный)

Факс: +7 495 668-12-70 (доб.304)

E-mail: [info@moschip.ru](mailto:info@moschip.ru)

Skype отдела продаж:

moschip.ru

moschip.ru\_4

moschip.ru\_6

moschip.ru\_9