

Features

- Monolithic IC reliability
- Low, matched, R_{ON}
- Eliminates the need for zero-cross switching
- Flexible switch timing for transition from ringing mode to talk mode.
- Clean, bounce-free switching
- SLIC tertiary protection via integrated current limiting, voltage clamping and thermal shutdown
- 5V operation with power consumption < 10.5 mW
- Intelligent battery monitor
- Logic-level inputs, no external drive circuitry required
- Compatible with Legerity 7583/8583 family
- Small 28-pin SOIC

Applications

- Central office (CO)
- Digital Loop Carrier (DLC)
- PBX Systems
- Digitally Added Main Line (DAML)
- Hybrid Fiber Coax (HFC)
- Fiber in the Loop (FITL)
- Pair Gain System
- Channel Banks

Description

The CPC7583 is a monolithic 10-pole line card access switch in a 28-pin SOIC package. It provides the necessary functions to replace three 2-Form-C electromechanical relays on analog line cards and combined voice and data line cards found in central office, access, and PBX equipment. The device contains solid state switches for tip and ring line break, ringing injection/ringing return, and test access. The CPC7583 requires only a +5 V supply and offers break-before-make or make-before-break switch operation.

Ordering Information

Part #	Description
CPC7583BA	28-Pin SOIC, 29/Tube
CPC7583BATR	28-Pin SOIC, 1000/Reel

Not for New Designs



1 Specifications	3
1.1 Package Pinout	3
1.2 Pinout Description	3
1.3 Absolute Maximum Ratings	4
1.4 ESD Rating	4
1.5 General Conditions	4
1.6 Switch Specifications	5
1.6.1 Break Switches, SW1 and SW2	5
1.6.2 Ringing Return Switch, SW3	6
1.6.3 Ringing Switch, SW4	7
1.6.4 TEST _{OUT} Switches, SW5 and SW6	8
1.6.5 Ringing Test Return Switch, SW7	9
1.6.6 Ringing Test Switch, SW8	10
1.6.7 TEST _{IN} Switches, SW9 and SW10	10
1.7 Additional Electrical Characteristics	11
1.8 Protection Circuitry Electrical Specifications	12
1.9 Truth Tables	12
1.9.1 Truth Table for CPC7583xA and CPC7583xB	12
1.9.2 Truth Table for CPC7583xC and CPC7583xD	13
2 Functional Description	14
2.1 Introduction	14
2.2 Switch Logic	14
2.2.1 Make-Before-Break Operation (Ringing to Talk Transition)	15
2.2.2 Break-Before-Make Operation (Ringing to Talk Transition)	15
2.3 Alternate Break-Before-Make Operation	15
2.4 Data Latch	16
2.5 T _{SD} Behavior	16
2.6 Ringing Switch Zero-Cross Current Turn Off	16
2.7 Power Supplies	16
2.8 Battery Voltage Monitor	16
2.9 Protection	16
2.9.1 Diode Bridge/SCR	16
2.9.2 Current Limiting function	17
2.10 Temperature Shutdown	17
2.11 External Protection Elements	17
3 Manufacturing Information	18
3.1 Mechanical Dimensions	19
3.1.1 CPC7583BA	19
3.1.2 CPC7583BATR Tape and Reel Specifications	19

1. Specifications

1.1 Package Pinout



1.2 Pinout Description

Pin#	Name	Description
1	F _{GND}	Fault ground.
2	NC	No connection.
3	NC	No connection.
4	NC	No connection.
5	T _{TESTin}	Tip lead of the TESTin bus.
6	T _{BAT}	Tip lead of the SLIC.
7	T _{LINE}	Tip lead of the line side.
8	T _{RINGING}	Ring generator return.
9	NC	Not connected.
10	T _{TESTout}	Tip lead of the TESTout bus.
11	NC	No connection.
12	V _{DD}	+5 V supply.
13	T _{SD}	Temperature shutdown pin.
14	D _{GND}	Digital ground.
15	IN _{TESTout}	Logic control input.
16	IN _{RINGING}	Logic control input.
17	IN _{TESTin}	Logic control input.
18	LATCH	Data latch enable control input.
19	R _{TESTout}	Ring lead of the TESTout bus.
20	R _{RINGING}	Ring generator source.
21	NC	No connection.
22	R _{LINE}	Ring lead of the line side.
23	R _{BAT}	Ring lead of the SLIC.
24	R _{TESTin}	Ring lead of the TESTin bus.
25	NC	No connection.
26	NC	No connection.
27	NC	No connection.
28	V _{BAT}	Battery supply.

1.3 Absolute Maximum Ratings

Parameter	Minimum	Maximum	Unit
Operating temperature	-40	+110	°C
Storage temperature	-40	+150	°C
Operating relative humidity	5	95	%
+5 V power supply (V _{DD})	-0.3	7	V
Battery Supply	-	-85	V
D _{GND} to F _{GND} separation	-5	+5	V
Logic input voltage	-0.3	V _{DD} +0.3	V
Logic input to switch output isolation	-	320	V
Switch open contact isolation (SW1, SW2, SW3, SW5, SW6, SW7, SW9, SW10)	-	320	V
Switch open contact isolation (SW4)	-	465	V
Switch open contact isolation (SW8)	-	235	V

Absolute maximum electrical ratings are at 25°C

Absolute maximum ratings are stress ratings. Stresses in excess of these ratings can cause permanent damage to the device. Functional operation of the device at conditions beyond those indicated in the operational sections of this data sheet is not implied.

1.4 ESD Rating

ESD Rating (Human Body Model)
1000 V

1.5 General Conditions

Unless otherwise specified, minimum and maximum values are production testing requirements.

Typical values are characteristic of the device at 25°C and are the result of engineering evaluations. They are provided for informational purposes only and are not part of the manufacturing testing requirements.

Specifications cover the operating temperature range T_A = -40°C to +85°C. Also, unless otherwise specified all testing is performed with V_{DD} = +5V_{dc}, logic low input voltage is 0V_{dc} and logic high input voltage is +5V_{dc}.

1.6 Switch Specifications

1.6.1 Break Switches, SW1 and SW2

Parameter	Test Conditions	Symbol	Minimum	Typical	Maximum	Unit
Off-state leakage current						
+25° C	V_{SW} (differential) = -320 V to gnd V_{SW} (differential) = +260 V to -60 V	I_{SW}	-	0.1	1	μA
+85° C	V_{SW} (differential) = -330 V to gnd V_{SW} (differential) = +270 V to -60 V			0.3		
-40° C	V_{SW} (differential) = -310 V to gnd V_{SW} (differential) = +250 V to -60 V			0.1		
R_{ON}						
+25° C	$I_{SW(on)}$ = ± 10 mA, ± 40 mA, R_{BAT} and T_{BAT} = -2 V	R_{ON}	-	14.5	-	Ω
+85° C				20.5	28	
-40° C				10.5	-	
R_{ON} match	Per on-resistance test condition of SW1 & SW2	ΔR_{ON}		0.15	0.8	
DC current limit						
+25° C	V_{SW} (on) = ± 10 V	I_{SW}	-	225	-	mA
+85° C			80	150		
-40° C			-	400	425	
Dynamic current limit ($t \leq 0.5 \mu s$)	Break switches on, ringing switches off, apply ± 1 kV 10x1000 μs pulse, with appropriate protection in place.		-	2.5	-	A
Logic input to switch output isolation						
+25° C	V_{SW} (T_{LINE} , R_{LINE}) = ± 320 V, logic inputs = gnd	I_{SW}	-	0.1	1	μA
+85° C	V_{SW} (T_{LINE} , R_{LINE}) = ± 330 V, logic inputs = gnd			0.3		
-40° C	V_{SW} (T_{LINE} , R_{LINE}) = ± 310 V, logic inputs = gnd			0.1		
dv/dt sensitivity	-	-	-	200	-	V/ μs

1.6.2 Ringing Return Switch, SW3

Parameter	Test Conditions	Symbol	Minimum	Typical	Maximum	Unit
Off-state leakage current						
+25° C	V_{SW} (differential) = -320 V to gnd V_{SW} (differential) = +260 V to -60 V	I_{SW}	-	0.1	1	μA
+85° C	V_{SW} (differential) = -330 V to gnd V_{SW} (differential) = +270 V to -60 V			0.3		
-40° C	V_{SW} (differential) = -310 V to gnd V_{SW} (differential) = +250 V to -60 V			0.1		
R_{ON}						
+25° C	$I_{SW(on)} = \pm 0 \text{ mA}, \pm 10 \text{ mA}$	R_{ON}	-	60	-	Ω
+85° C				85	110	
-40° C				45	-	
DC current limit						
+25° C	$V_{SW} (on) = \pm 10 \text{ V}$	I_{SW}	-	120	-	mA
+85° C			70	85		
-40° C			-	210		
Dynamic current limit ($t \leq 0.5 \mu s$)	Break switches off, ringing switches on, apply $\pm 1 \text{ kV } 10 \times 1000 \mu s$ pulse, with appropriate protection in place.		-	2.5		A
Logic input to switch output isolation						
+25° C	$V_{SW} (T_{RING}, T_{LINE}) = \pm 320 \text{ V}$, logic inputs = gnd	I_{SW}	-	0.1	1	μA
+85° C	$V_{SW} (T_{RING}, T_{LINE}) = \pm 330 \text{ V}$, logic inputs = gnd			0.3		
-40° C	$V_{SW} (T_{RING}, T_{LINE}) = \pm 310 \text{ V}$, logic inputs = gnd			0.1		
dv/dt sensitivity	-	-	-	200	-	V/ μs

1.6.3 Ringing Switch, SW4

Parameter	Test Conditions	Symbol	Minimum	Typical	Maximum	Unit
Off-state leakage current						
+25° C	V _{SW} (differential) = -255 V to +210 V V _{SW} (differential) = +255 V to -210 V	I _{SW}	-	0.05	1	μA
+85° C	V _{SW} (differential) = -270 V to +210 V V _{SW} (differential) = +270 V to -210 V			0.1	1	
-40° C	V _{SW} (differential) = -245 V to +210 V V _{SW} (differential) = +245 V to -210 V			0.05	1	
On Voltage	I _{SW} (on) = ± 1 mA	-	-	1.5	3	V
Ringing generator current to ground during ringing	Inputs set for ringing mode	I _{RINGING}	-	0.1	0.25	mA
On steady-state current*	Inputs set for ringing mode	I _{SW}	-	-	150	mA
Surge current*	-	-	-	-	2	A
Release current	-	I _{RINGING}	-	450	-	μA
R _{ON}	I _{SW} (on) = ±70 mA, ±80 mA	R _{ON}	-	10	15	Ω
Logic input to switch output isolation						
+25° C	V _{SW} (R _{RING} , R _{LINE}) = ±320 V, logic inputs = gnd	I _{SW}	-	0.1	1	μA
+85° C	V _{SW} (R _{RING} , R _{LINE}) = ±330 V, logic inputs = gnd			0.3		
-40° C	V _{SW} (R _{RING} , R _{LINE}) = ±310 V, logic inputs = gnd			0.1		
dv/dt sensitivity	-	-	-	200	-	V/μs
*Secondary protection and ringing source current limiting must prevent exceeding this parameter.						

1.6.4 TEST_{OUT} Switches, SW5 and SW6

Parameter	Test Conditions	Symbol	Minimum	Typical	Maximum	Unit
Off-state leakage current						
+25° C	V _{SW} (differential) = -320 V to gnd V _{SW} (differential) = +260 V to -60 V	I _{SW}	-	0.1	1	μA
+85° C	V _{SW} (differential) = -330 V to gnd V _{SW} (differential) = +260 V to -60 V			0.3		
-40° C	V _{SW} (differential) = -310 V to gnd V _{SW} (differential) = +250 V to -60 V			0.1		
R_{ON}						
+25° C	I _{SW(on)} = ±10 mA, ±40 mA	R _{ON}	-	35	-	Ω
+85° C				50	70	
-40° C				26	-	
DC current limit						
+25° C	V _{SW} (on) = ±10 V	I _{SW}	-	140	-	mA
+85° C			80	100	-	
-40° C			-	210	250	
Dynamic current limit (t ≤ 0.5 μs)	Break switches in on state, ringing switches off, apply ±1 kV at 10x1000 μs pulse, with appropriate secondary protection in place.	I _{SW}	-	2.5	-	A
Logic input to switch output isolation						
+25° C	V _{SW} (T _{TESTout} , T _{LINE} , R _{TESTout} , R _{LINE}) = ±320 V, logic inputs = gnd	I _{SW}	-	0.1	1	μA
+85° C	V _{SW} (T _{TESTout} , T _{LINE} , R _{TESTout} , R _{LINE}) = ±330 V, logic inputs = gnd	I _{SW}	-	0.3	1	μA
-40° C	V _{SW} (T _{TESTout} , T _{LINE} , R _{TESTout} , R _{LINE}) = ±310 V, logic inputs = gnd	I _{SW}	-	0.1	1	μA
dv/dt sensitivity	-	-	-	200	-	V/μs

1.6.5 Ringing Test Return Switch, SW7

Parameter	Test Conditions	Symbol	Minimum	Typical	Maximum	Unit
Off-state leakage current						
+25° C	V_{SW} (differential) = -320 V to gnd V_{SW} (differential) = +260 to -60 V	I_{SW}	-	0.1	1	μA
+85° C	V_{SW} (differential) = -330 V to gnd V_{SW} (differential) = +270 V to -60 V			0.3		
-40° C	V_{SW} (differential) = -310 V to gnd V_{SW} (differential) = +250 V to -60 V			0.1		
R_{ON}						
+25° C	$I_{SW(on)} = \pm 10$ mA, ± 40 mA	R_{ON}	-	60	-	Ω
+85° C				85	100	
-40° C				45	-	
DC current limit						
+25° C	V_{SW} (on) = ± 10 V	I_{SW}	70	120	-	mA
+85° C				80		
-40° C				210		
Logic input to switch output isolation						
+25° C	V_{SW} (T_{RING} , T_{TESTin}) = ± 320 V, logic inputs = gnd	I_{SW}	-	0.1	1	μA
+85° C	V_{SW} (T_{RING} , T_{TESTin}) = ± 330 V, logic inputs = gnd			0.3		
-40° C	V_{SW} (T_{RING} , T_{TESTin}) = ± 310 V, logic inputs = gnd			0.1		
dv/dt sensitivity	-	-	-	200	-	V/ μs

1.6.6 Ringing Test Switch, SW8

Parameter	Test Conditions	Symbol	Minimum	Typical	Maximum	Unit
Off-state leakage current						
+25° C	V_{SW} (differential) = -60 V to +175 V	I_{SW}	-	0.05	1	μA
+85° C				0.1		
-40° C				0.05		
On Voltage	$I_{SW(ON)} = \pm 1$ mA	-	-	0.75	1.5	V
R_{ON}	$I_{SW(ON)} = \pm 70$ mA, ± 80 mA	R_{ON}	-	35	-	Ω
Release Current	-	-	-	450	-	μA
Logic input to switch output isolation						
+25° C	V_{SW} (R_{RING} , R_{TESTin}) = ± 320 V, logic inputs = gnd	I_{SW}	-	0.1	1	μA
+85° C	V_{SW} (R_{RING} , R_{TESTin}) = ± 330 V, logic inputs = gnd			0.3		
-40° C	V_{SW} (R_{RING} , R_{TESTin}) = ± 310 V, logic inputs = gnd			0.1		
dv/dt sensitivity	-	-	-	200	-	V/ μs

1.6.7 $TEST_{in}$ Switches, SW9 and SW10

Parameter	Test Conditions	Symbol	Minimum	Typical	Maximum	Unit
Off-state leakage current						
+25° C	V_{SW} (differential) = -320 V to gnd V_{SW} (differential) = -60 V to +260 V	I_{SW}	-	0.1	1	μA
+85° C	V_{SW} (differential) = -330 V to gnd V_{SW} (differential) = -60 V to +270 V			0.3		
-40° C	V_{SW} (differential) = -310 V to gnd V_{SW} (differential) = -60 V to +250 V			0.1		
R_{ON}						
+25° C	$I_{SW(on)} = \pm 10$ mA, ± 40 mA	R_{ON}	-	35	-	Ω
+85° C				50	70	
-40° C				26	-	
DC current limit						
+25° C	V_{SW} (on) = ± 10 V	I_{SW}	-	160	-	mA
+85° C			80	110	-	
-40° C			-	210	250	
Logic input to switch output isolation						
+25° C	V_{SW} (T_{TESTin} , R_{TESTin}) = ± 320 V, logic inputs = gnd	I_{SW}	-	0.1	1	μA
+85° C	V_{SW} (T_{TESTin} , R_{TESTin}) = ± 330 V, logic inputs = gnd			0.3		
-40° C	V_{SW} (T_{TESTin} , R_{TESTin}) = ± 310 V, logic inputs = gnd			0.1		
dv/dt sensitivity	-	-	-	200	-	V/ μs

1.7 Additional Electrical Characteristics

Parameter	Test Conditions	Symbol	Minimum	Typical	Maximum	Unit
Digital Inputs						
Input low voltage	-	V_{IL}	-	-	1.5	V
Input high voltage	-	V_{IH}	3.5	-	-	
Input leakage current (high)	$V_{DD} = 5.5\text{ V}, V_{BAT} = -75\text{ V}, V_{IH} = 5\text{ V}$	I_{IH}	-	0.1	1	μA
Input leakage current (low)	$V_{DD} = 5.5\text{ V}, V_{BAT} = -75\text{ V}, V_{IL} = 0\text{ V}$	I_{IL}	-	0.1	1	
Voltage Requirements						
V_{DD}	-	V_{DD}	4.5	5.0	5.5	V
V_{BAT}^1	-	V_{BAT}	-19	-	-72	V
<i>¹V_{BAT} is used only for internal protection circuitry. If V_{BAT} goes more positive than -10 V, the device will enter the all-off state and will remain in the all-off state until the battery goes more negative than -15 V</i>						
Power Requirements						
Power consumption in talk and all-off states	$V_{DD} = 5\text{ V}, V_{BAT} = -48\text{ V}$, measure I_{DD} and I_{BAT}	P	-	3.5	7.5	mW
Power consumption in any other state	$V_{DD} = 5\text{ V}, V_{BAT} = -48\text{ V}$, measure I_{DD} and I_{BAT}	P	-	5.0	10.5	
V_{DD} current in talk and all-off states	$V_{DD} = 5\text{ V}, V_{BAT} = -48\text{ V}$	I_{DD}	-	0.7	1.5	mA
V_{DD} current in any other state		I_{DD}	-	1.0	1.9	
V_{BAT} current in any state	$V_{DD} = 5\text{ V}, V_{BAT} = -48\text{ V}$	I_{BAT}	-	4	10	μA
Temperature Shutdown Requirements (temperature shutdown flag is active low)						
Shutdown activation temperature	Not production tested - limits are guaranteed by design and Quality Control sampling audits.	T_{SD_on}	110	125	150	$^{\circ}\text{C}$
Shutdown circuit hysteresis		T_{SD_off}	10	-	25	$^{\circ}\text{C}$

1.8 Protection Circuitry Electrical Specifications

Parameter	Conditions	Symbol	Minimum	Typical	Maximum	Unit
Parameters Related to the Diodes in the Diode Bridge						
Voltage drop at continuous current (50/60 Hz)	Apply ± dc current limit of break switches	Forward Voltage	-	2.8	3.5	V
Voltage drop at surge current	Apply ± dynamic current limit of break switches	Forward Voltage	-	5	-	
Parameters Related to the Protection SCR (CPC7583xA and CPC7583xC)						
Surge current		-	-	-	*	A
Trigger current	+25° C	I_{TRIG}	-	200	-	mA
	+85° C	I_{TRIG}	-	120	-	
Hold current	+25° C	I_{HOLD}	-	265	-	
	+85° C	I_{HOLD}	100	170	-	
Gate trigger voltage	$I_{GATE} = I_{TRIGGER}^{\$}$	V_{TBAT} or V_{RBAT}	$V_{BAT} - 4$	-	$V_{BAT} - 2$	V
Reverse leakage current	$V_{BAT} = -48$ V	I_{VBAT}	-	-	1.0	μA
On-state voltage	0.5 A, t = 0.5 μs	V_{TBAT} or V_{RBAT}	-	-3	-	V
	2.0 A, t = 0.5 μs		-	-5	-	V

*Passes GR1089 and ITU-T K.20 with appropriate secondary protection in place.
^{\\$} V_{BAT} must be capable of sourcing $I_{TRIGGER}$ for the internal SCR to activate.

1.9 Truth Tables

1.9.1 Truth Table for CPC7583xA and CPC7583xB

State	$I_{NRINGING}$	$I_{NTESTIN}$	$I_{NTESTOUT}$	Latch	T_{SD}	TEST _{IN} Switches	Break Switches	Ringing Test Switches	Ringing Switches	TEST _{OUT} Switches	
Talk	0	0	0	0	1 or Floating ¹	Off	On	Off	Off	Off	
TEST _{Out}	0	0	1			Off	Off	Off	Off	Off	On
TEST _{In}	0	1	0			On	Off	Off	Off	Off	Off
Simultaneous TEST _{In} and TEST _{Out}	0	1	1			On	Off	Off	Off	Off	On
Ringing	1	0	0			Off	Off	Off	Off	On	Off
Ringing Generator Test	1	1	0			Off	Off	On	Off	Off	Off
Latched	X	X	X			1	Unchanged	Unchanged	Unchanged	Unchanged	Unchanged
All Off	1	0	1	0	Off	Off	Off	Off	Off	Off	
	1	1	1	0	Off	Off	Off	Off	Off	Off	
	X	X	X	X	0 ²	Off	Off	Off	Off	Off	

¹If T_{SD} is tied high, thermal shutdown is disabled. If T_{SD} is left floating, the thermal shutdown mechanism functions normally.

²Forcing T_{SD} to ground overrides the logic input pins and forces an all off state.

1.9.2 Truth Table for CPC7583xC and CPC7583xD

State	INRINGING	INTESTIN	INTESTOUT	Latch	TSD	TEST _{IN} Switches	Break Switches	Ringing Test Switches	Ringing Switches	TEST _{OUT} Switches	
Talk	0	0	0	0	1 or Floating ¹	Off	On	Off	Off	Off	
TESTout	0	0	1			Off	Off	Off	Off	Off	On
TESTin	0	1	0			On	Off	Off	Off	Off	Off
Simultaneous TESTin and TESTout	0	1	1			On	Off	Off	Off	Off	On
Ringing	1	0	0			Off	Off	Off	On	Off	Off
Ringing Generator Test	1	1	0			Off	Off	On	Off	Off	Off
Simultaneous TESTout and Ringing Generator Test	1	1	1			Off	Off	On	Off	Off	On
Latched	X	X	X			1	Unchanged	Unchanged	Unchanged	Unchanged	Unchanged
All Off	1	0	1	0	0 ²	Off	Off	Off	Off	Off	
	X	X	X	X		Off	Off	Off	Off	Off	

¹If T_{SD} is tied high, thermal shutdown is disabled. If T_{SD} is left floating, the thermal shutdown mechanism functions normally.

²Forcing T_{SD} to ground overrides the logic input pins and forces an all off state.

2. Functional Description

2.1 Introduction

The CPC7583 has the following states:

- **Talk.** Loop break switches SW1, and SW2 closed, all other switches open.
- **Ringing.** Ringing switches SW3, SW4 closed, all other switches open.
- **TESTout.** Testout switches SW5, SW6 closed, all other switches open.
- **Ringing generator test.** SW7, SW8 closed, all other switches open.
- **TESTin.** Testin switches SW9 and SW10 closed.
- **Simultaneous TESTin and TESTout.** SW9, SW10, SW5, and SW6 closed, all other switches open.
- **Simultaneous test out and ringing generator test.** SW5, SW6, SW7, and SW8 closed, all other switches open (only on the xC and xD versions).
- **All Off.** All switches open.

See “[Truth Tables](#)” on page 12 for more information.

The CPC7583 offers break-before-make and make-before-break switching from the ringing state to the talk state with simple logic level input control. Solid-state switch construction means no impulse noise is generated when switching during ringing cadence or ring trip, eliminating the need for external zero-cross switching circuitry. State-control is via logic-level input so no additional driver circuitry is required. The linear line break switches SW1 and SW2 have exceptionally low R_{ON} and excellent matching characteristics. The ringing switch SW4 has a minimum open contact breakdown voltage of 465 V. This is sufficiently high, with proper protection, to prevent breakdown in the presence of a transient fault condition (i.e., passing the transient on to the ringing generator).

Integrated into the CPC7583 is an over voltage clamping circuit, active current limiting, and a thermal shutdown mechanism to provide protection to the SLIC device during a fault condition. Positive and negative surges are reduced by the current limiting circuitry and hazardous potentials are diverted to ground via diodes and the integrated SCR. Power-cross potentials are also reduced by the current limiting and thermal shutdown circuits.

To protect the CPC7583 from an overvoltage fault condition, the use of a secondary protector is required. The secondary protector must limit the voltage seen at the T_{LINE} and R_{LINE} terminals to a level below the maximum breakdown voltage of the switches. To minimize the stress on the solid-state contacts, use of a foldback or crowbar type secondary protector is recommended. With proper selection of the secondary protector, a line card using the CPC7583 will meet all relevant ITU, LSSGR, TIA/EIA and IEC protection requirements.

The CPC7583 operates from a +5 V supply only. This gives the device extremely low idle and active power consumption and allows use with virtually any range of battery voltage. The battery voltage is also used by the CPC7583 as a reference for the integrated protection circuit. In the event of a loss of battery voltage, the CPC7583 enters the all-off state.

2.2 Switch Logic

The CPC7583 provides, when switching from the ringing state to the talk state, the ability to control the release timing of the ringing switches SW3 and SW4 relative to the state of the loop break switches SW1 and SW2 using simple logic-level input. This is referred to as a make-before-break or break-before-make operation. When the line break switch contacts (SW1 and SW2) are closed (or made) before the ringing access switch contacts (SW3 and SW4) are opened (broken), this is referred to as make-before-break operation. Break-before-make operation occurs when the ringing access contacts (SW3 and SW4) are opened (broken) before the line break switch contacts (SW1 and SW2) are closed (made). With the CPC7583, the make-before-break and break-before-make operations can easily be selected by applying the proper sequence of logic inputs to $IN_{TESTout}$, $IN_{RINGING}$, and IN_{TESTin} .

The logic sequences for either mode of operation are given in “[Make-Before-Break Operation \(Ringing to Talk Transition\)](#)” on page 15 and “[Break-Before-Make Operation \(Ringing to Talk Transition\)](#)” on page 15. Logic states and explanations are given in “[Truth Tables](#)” on page 12.

Break-before-make operation can also be achieved using the T_{SD} pin as an input. In “**Break-Before-Make Operation (Ringing to Talk Transition)**” on page 15, lines 2 and 3, it is possible to induce the switches to the all-off state by grounding T_{SD} instead of applying input to the logic pins. This has the effect of overriding the logic

inputs and forcing the device to the all-off state. For 20 Hz ringing hold this input state for 25 ms. During this hold period, toggle the inputs from the ringing state to the talk state. After the 25 ms, release T_{SD} to return switch control to the input pins $IN_{TESTout}$, $IN_{RINGING}$, IN_{TESTin} and the latch control pin.

2.2.1 Make-Before-Break Operation (Ringing to Talk Transition)

State	$IN_{RINGING}$	IN_{TESTIN}	$IN_{TESTOUT}$	Latch	T_{SD}	Timing	Break Switches 1 and 2	Ring Return Switch 3	Ring Access Switch 4	All Other Test Switches
Ringing	1	0	0	0	Floating	-	Off	On	On	Off
Make-before-break	0	0	0		Floating	SW4 waiting for next zero-current crossing to turn off. Maximum time is one-half of ringing. In this transition state, current that is limited to the dc break switch current limit value will be sourced from the ring node of the SLIC.	On	Off	On	Off
Talk	0	0	0		Floating	Zero-cross current has occurred	On	Off	Off	Off

2.2.2 Break-Before-Make Operation (Ringing to Talk Transition)

State	$IN_{RINGING}$	IN_{TESTIN}	$IN_{TESTOUT}$	Latch	T_{SD}	Timing	Break Switches 1 and 2	Ring Return Switch 3	Ring Access Switch 4	All Other Test Switches
Ringing	1	0	0	0	Floating	-	Off	On	On	Off
All off	1	0	1		Floating	Hold this state for one-half of ringing cycle. SW4 waiting for zero current to turn off.	Off	Off	On	Off
All off	1	0	1		Floating	Zero current has occurred. SW4 has opened	Off	Off	Off	Off
Talk	0	0	0		Floating	Close break switches	On	Off	Off	Off

2.3 Alternate Break-Before-Make Operation

Note that break-before-make operation can also be achieved using T_{SD} as an input. In lines 2 and 3 of the table “**Break-Before-Make Operation (Ringing to Talk Transition)**” on page 15, instead of using the logic input pins to force the all-off state, force T_{SD} to ground. This overrides the logic inputs and also forces the all off state. Hold this state for one-half of the ringing cycle. During this T_{SD} forced all-off state, change the inputs

from the power ringing state ($IN_{RING} = 1$, $IN_{TESTIN} = 0$, $IN_{TESTOUT} = 0$) to the talk state ($IN_{RING} = 0$, $IN_{TESTIN} = 0$, $IN_{TESTOUT} = 0$). After the hold period, release T_{SD} to return switch control to the input pins which will set the talk state.

2.4 Data Latch

The CPC7583 has an integrated data latch. The latch operation is controlled by logic-level input at the LATCH pin. The data input of the latch are the input pins, while the output of the data latch is an internal node used for state control. When the LATCH control pin is at logic 0, the data latch is transparent and data control signals flow directly through to state control. A change in input will be reflected by a change in switch state. When the LATCH control pin is at logic 1, the data latch is active and a change in input control will not affect switch state. The switches will remain in the position they were in when the LATCH changed from logic 0 to logic 1 and will not respond to changes in input as long as the latch is at logic 1. The T_{SD} input is not tied to the data latch. Therefore, T_{SD} is not affected by the LATCH input and the T_{SD} input will override state control.

2.5 T_{SD} Behavior

Setting T_{SD} to +5V allows switch control using the logic inputs. This setting, however, also disables the thermal shutdown circuit and is therefore not recommended. When using logic control via the input pins, T_{SD} should be allowed to float. As a result, the two recommended states when using T_{SD} as a control are 0, which forces the device to an all-off state, or float, which allows logic inputs to remain active. This requires the use of an open-collector type buffer.

2.6 Ringing Switch Zero-Cross Current Turn Off

After the application of a logic input to turn SW4 off, the ringing switch is designed to delay the change in state until the next zero-crossing. Once on, the switch requires a zero-current cross to turn off, and therefore should not be used to switch a pure DC signal. The switch will remain in the on state no matter the logic input until the next zero crossing. These switching characteristics will reduce and possibly eliminate overall system impulse noise normally associated with ringing switches. See IXYS Integrated Circuits Division's application note [AN-144, Impulse Noise Benefits of Line Card Access Switches](#) for more information. The attributes of ringing switch SW4 may make it possible to eliminate the need for a zero-cross switching scheme. A minimum impedance of 300 Ω in series with the ringing generator is recommended.

2.7 Power Supplies

Both a +5 V supply and battery voltage are connected to the CPC7583. Switch state control is powered exclusively by the +5 V supply. As a result, the CPC7583 exhibits extremely low power consumption during both active and idle states.

The battery voltage is not used for switch control but rather as a supply for the integrated secondary protection circuitry. The integrated SCR is designed to trigger when the voltage at T_{BAT} or R_{BAT} drops 2 to 4 V below the applied voltage on the V_{BAT} pin. This trigger prevents a fault induced overvoltage event at the T_{BAT} or R_{BAT} nodes.

2.8 Battery Voltage Monitor

The CPC7583 also uses the V_{BAT} voltage to monitor battery voltage. If battery voltage is lost, the CPC7583 immediately enters the all-off state. It remains in this state until the battery voltage is restored. The device also enters the all-off state if the system battery voltage goes more positive than -10 V, and remains in the all-off state until the battery voltage goes more negative than -15 V. This battery monitor feature draws a small current from the battery (less than 1 μ A typical) and will add slightly to the device's overall power dissipation.

2.9 Protection

2.9.1 Diode Bridge/SCR

The CPC7583 uses a combination of current limited break switches, a diode bridge/SCR clamping circuit, and a thermal shutdown mechanism to protect the SLIC device or other associated circuitry from damage during line transient events such as lightning. During a positive transient condition, the fault current is conducted through the diode bridge to ground via F_{GND} . Voltage is clamped to a diode drop above ground. During a negative transient of 2V to 4V more negative than the voltage source at V_{BAT} , the SCR conducts and faults are shunted to F_{GND} via the SCR or the diode bridge.

In order for the SCR to crowbar or foldback, the on voltage (see "[Protection Circuitry Electrical Specifications](#)" on page 12) of the SCR must be less negative than the V_{BAT} voltage. If the V_{BAT} voltage is less negative than the SCR on voltage, or if the V_{BAT} supply is unable to source the trigger current, the SCR will not crowbar.

For power induction or power-cross fault conditions, the positive cycle of the transient is clamped to a diode drop above ground and the fault current directed to ground. The negative cycle of the transient will cause the SCR to conduct when the voltage exceeds the V_{BAT} reference voltage by two to four volts, steering the fault current to ground.

2.9.2 Current Limiting function

If a lightning strike transient occurs when the device is in the talk state, the current is passed along the line to the integrated protection circuitry and restricted by the dynamic current limit response of the active switches. During the talk state when a 1000V 10x1000 μ S pulse (GR-1089-CORE lightning) is applied to the line through a properly clamped external protector, the current into T_{LINE} or R_{LINE} will be a pulse with a typical magnitude of 2.5 A and a duration of less than 0.5 μ s.

If a power-cross fault occurs with the device in the talk state, the current is passed through break switches SW1 and SW2 on to the integrated protection circuit and is limited by the dynamic DC current limit response of the two break switches. The DC current limit, specified over temperature, is between 80 mA and 425 mA, and the circuitry has a negative temperature coefficient. As a result, if the device is subjected to extended heating due to power cross fault, the measured current at T_{LINE} or R_{LINE} will decrease as the device temperature increases. If the device temperature rises sufficiently, the temperature shutdown mechanism will activate and the device will enter the all-off state.

2.10 Temperature Shutdown

The thermal shutdown mechanism will activate when the device temperature reaches a minimum of 110° C, placing the device in the all-off state regardless of logic input. During thermal shutdown mode, the voltage out of the T_{SD} pin will read 0 V. Normal output of T_{SD} is V_{DD} .

If presented with a short duration transient such as a lightning event, the thermal shutdown feature will typically not activate. But in an extended power-cross transient, the device temperature will rise and the thermal shutdown will activate forcing the switches to the all-off state. At this point the current measured into T_{LINE} or R_{LINE} will drop to zero. Once the device enters thermal shutdown it will remain in the all-off state until the temperature of the device drops below

the deactivation level of the thermal shutdown circuit. This will permit the device to return to normal operation. If the transient has not passed, current will flow up to the value allowed by the dynamic DC current limiting of the switches and heating will begin again, reactivating the thermal shutdown mechanism. This cycle of entering and exiting the thermal shutdown mode will continue as long as the fault condition persists. If the magnitude of the fault condition is great enough, the external secondary protector could activate and shunt all current to ground.

2.11 External Protection Elements

The CPC7583 requires only over-voltage secondary protection on the loop side of the device. The integrated protection feature described above negates the need for additional protection on the SLIC side. The secondary protector must limit voltage transients to levels that do not exceed the breakdown voltage or input-output isolation barrier of the CPC7583. A foldback or crowbar type protector is recommended to minimize stresses on the CPC7583.

Consult IXYS Integrated Circuits Division's application note, AN-100, "**Designing Surge and Power Fault Protection Circuits for Solid State Subscriber Line Interfaces**" for equations related to the specifications of external secondary protectors, fused resistors and PTCs.

3 Manufacturing Information

3.1 Moisture Sensitivity



All plastic encapsulated semiconductor packages are susceptible to moisture ingress. IXYS Integrated Circuits Division classified all of its plastic encapsulated devices for moisture sensitivity according to the latest version of the joint industry standard, **IPC/JEDEC J-STD-020**, in force at the time of product evaluation. We test all of our products to the maximum conditions set forth in the standard, and guarantee proper operation of our devices when handled according to the limitations and information in that standard as well as to any limitations set forth in the information or standards referenced below.

Failure to adhere to the warnings or limitations as established by the listed specifications could result in reduced product performance, reduction of operable life, and/or reduction of overall reliability.

This product carries a **Moisture Sensitivity Level (MSL) rating** as shown below, and should be handled according to the requirements of the latest version of the joint industry standard **IPC/JEDEC J-STD-033**.

Device	Moisture Sensitivity Level (MSL) Rating
CPC7583BA	MSL 1

3.2 ESD Sensitivity



This product is **ESD Sensitive**, and should be handled according to the industry standard **JESD-625**.

3.3 Reflow Profile

This product has a maximum body temperature and time rating as shown below. All other guidelines of **J-STD-020** must be observed.

Device	Maximum Temperature x Time
CPC7583BA	260°C for 30 seconds

3.4 Board Wash

IXYS Integrated Circuits Division recommends the use of no-clean flux formulations. However, board washing to remove flux residue is acceptable, and the use of a short drying bake may be necessary. Chlorine-based or Fluorine-based solvents or fluxes should not be used. Cleaning methods that employ ultrasonic energy should not be used.



3.5 Mechanical Dimensions

3.5.1 CPC7583BA

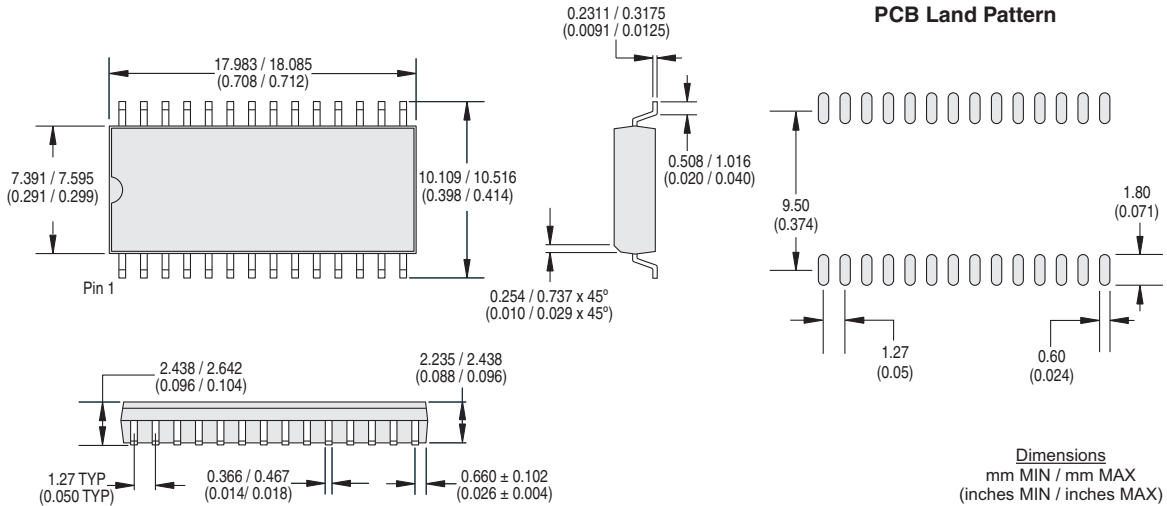

3.5.2 CPC7583BATR Tape and Reel Specifications

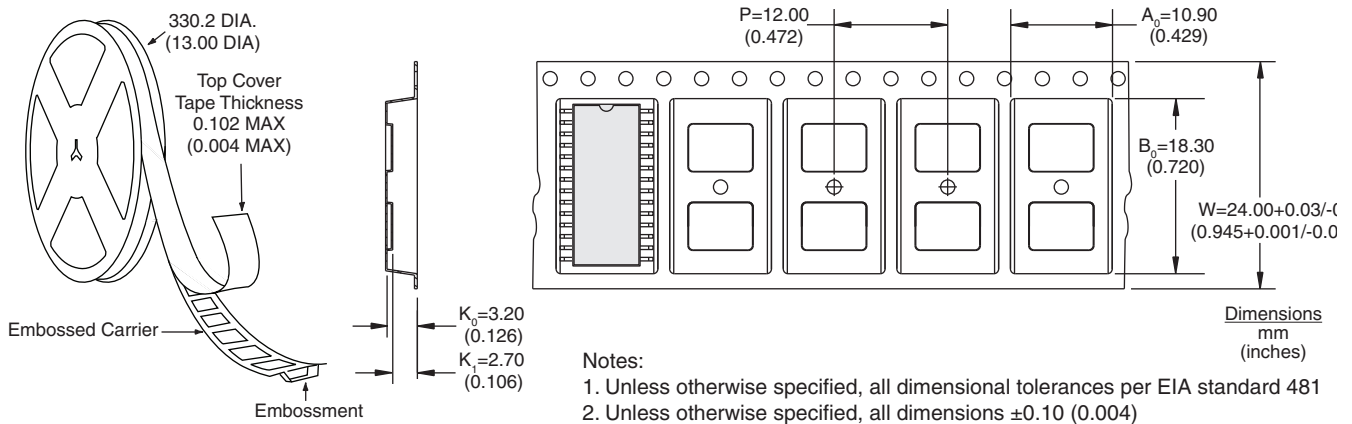

For additional information please visit www.ixysic.com

IXYS Integrated Circuits Division makes no representations or warranties with respect to the accuracy or completeness of the contents of this publication and reserves the right to make changes to specifications and product descriptions at any time without notice. Neither circuit patent licenses or indemnity are expressed or implied. Except as set forth in IXYS Integrated Circuits Division's Standard Terms and Conditions of Sale, IXYS Integrated Circuits Division assumes no liability whatsoever, and disclaims any express or implied warranty relating to its products, including, but not limited to, the implied warranty of merchantability, fitness for a particular purpose, or infringement of any intellectual property right.

The products described in this document are not designed, intended, authorized, or warranted for use as components in systems intended for surgical implant into the body, or in other applications intended to support or sustain life, or where malfunction of IXYS Integrated Circuits Division's product may result in direct physical harm, injury, or death to a person or severe property or environmental damage. IXYS Integrated Circuits Division reserves the right to discontinue or make changes to its products at any time without notice.

Specifications: DS-CPC7583-R07
© Copyright 2012, IXYS Integrated Circuits Division
All rights reserved. Printed in USA.
12/18/2012

Данный компонент на территории Российской Федерации

Вы можете приобрести в компании MosChip.

Для оперативного оформления запроса Вам необходимо перейти по данной ссылке:

<http://moschip.ru/get-element>

Вы можете разместить у нас заказ для любого Вашего проекта, будь то серийное производство или разработка единичного прибора.

В нашем ассортименте представлены ведущие мировые производители активных и пассивных электронных компонентов.

Нашей специализацией является поставка электронной компонентной базы двойного назначения, продукции таких производителей как XILINX, Intel (ex.ALTERA), Vicor, Microchip, Texas Instruments, Analog Devices, Mini-Circuits, Amphenol, Glenair.

Сотрудничество с глобальными дистрибьюторами электронных компонентов, предоставляет возможность заказывать и получать с международных складов практически любой перечень компонентов в оптимальные для Вас сроки.

На всех этапах разработки и производства наши партнеры могут получить квалифицированную поддержку опытных инженеров.

Система менеджмента качества компании отвечает требованиям в соответствии с ГОСТ Р ИСО 9001, ГОСТ РВ 0015-002 и ЭС РД 009

Офис по работе с юридическими лицами:

105318, г.Москва, ул.Щербаковская д.3, офис 1107, 1118, ДЦ «Щербаковский»

Телефон: +7 495 668-12-70 (многоканальный)

Факс: +7 495 668-12-70 (доб.304)

E-mail: info@moschip.ru

Skype отдела продаж:

moschip.ru

moschip.ru_4

moschip.ru_6

moschip.ru_9