

## High-Voltage Output Hysteretic-Mode Step-Up DC/DC Controller

### Features

- 6V to 500V Wide Output Voltage Range
- 2.7V Low Input Voltage
- 5W Maximum Output Power with External MOSFET Driver
- Built-in Charge Pump Converter for the Gate Driver
- Programmable Switching Frequency from 40 kHz to 400 kHz
- Four Programmable Duty Cycles from 50% to 87.5%
- FB Return Ground Switch for Power-Saving Applications
- Built-In Delay Timer for Internal Protection
- Non-Isolated DC/DC Converter

### Applications

- Portable Electronic Equipment
- MEMS
- Printers

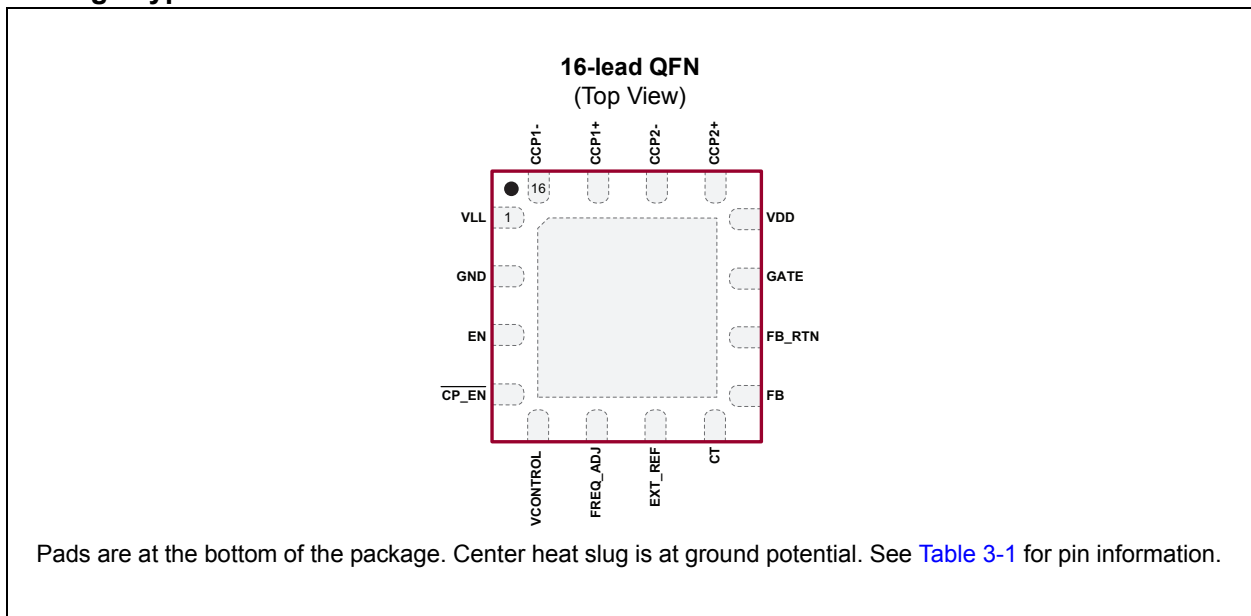
### General Description

The HV9150 is a high output voltage Hysteretic mode step-up DC/DC controller that has a built-in charge pump converter and a linear regulator for a wide range of input voltage. The Charge Pump Converter mode is ideal for battery-powered applications. The internal converter can provide a minimum of 5V gate driver output voltage (at  $V_{IN} = 2.7V$ ) to the external N-channel MOSFET. The range of 2.7V to 4.5V input supply voltage is ideal for battery-powered applications, such as portable electronic equipment. The internal linear regulator is selected when a higher supply voltage rail is available in the system.

A feedback return ground path switch is also integrated into the device to minimize the quiescent current during the controller shutdown. This feature provides power savings for energy-critical applications.

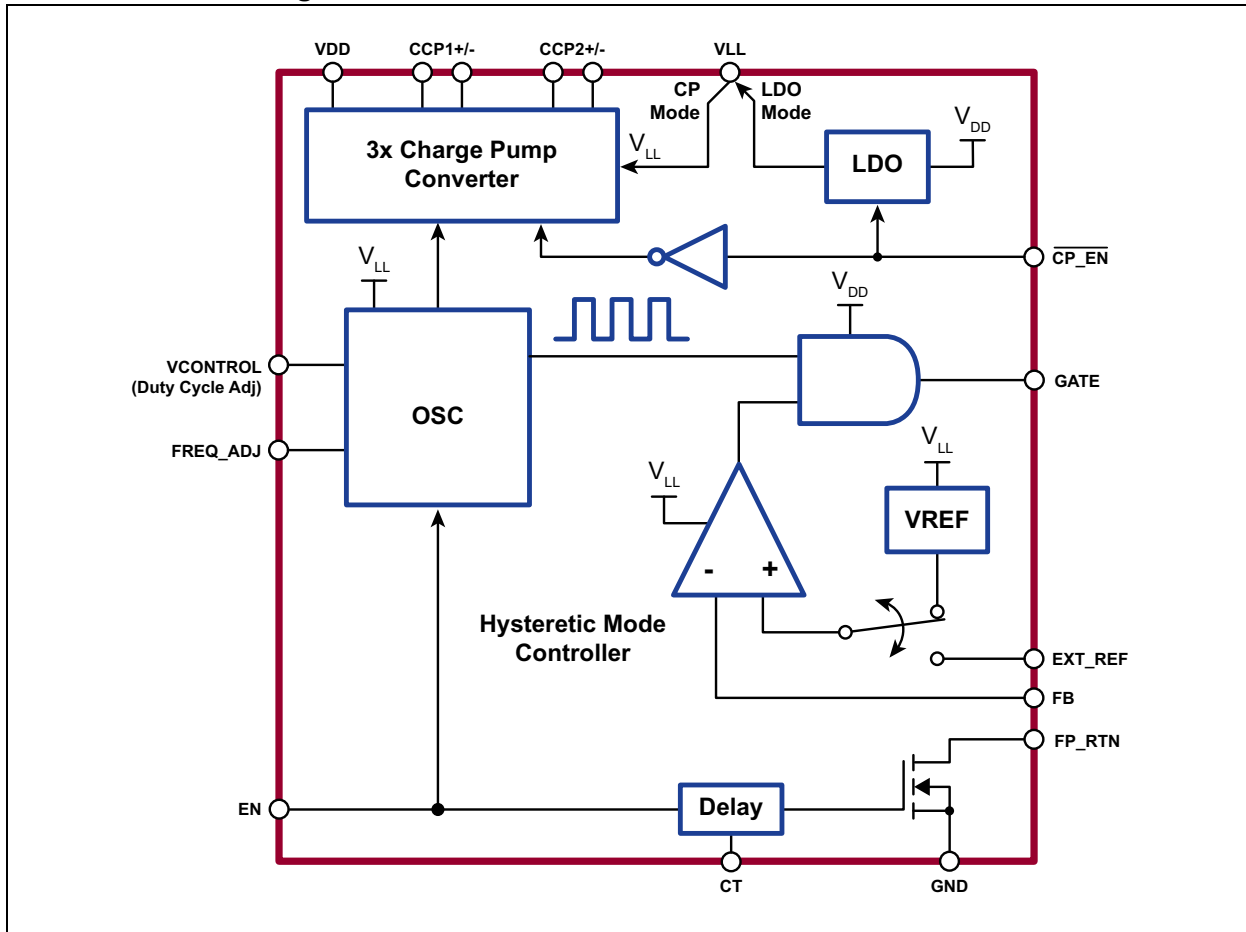
In addition, a built-in timer is available to protect the internal circuit and help dissipate the energy from the external high-voltage storage capacitor. This device is designed for systems requiring high-voltage and low-current applications such as MEMS devices.

### Package Type



# HV9150

## Functional Block Diagram





# HV9150

## 1.0 ELECTRICAL CHARACTERISTICS

### Absolute Maximum Ratings†

Input Voltage Supply, $V_{LL}$ .....	-0.5V to +5V
Charge Pump Output Voltage, $V_{DD}$ .....	-0.5V to +13.6V
Logic Input Levels .....	-0.5V to $V_{LL} + 0.5V$
Operating Ambient Temperature, $T_A$ .....	-25°C to +125°C
Storage Temperature, $T_S$ .....	-65°C to +150°C
Continuous Power Dissipation (On a 3 x 4-inch FR4 PCB at $T_A = 25^\circ\text{C}$ ):	
16-lead QFN .....	3000 mW

† **Notice:** Stresses above those listed under “Absolute Maximum Ratings” may cause permanent damage to the device. This is a stress rating only, and functional operation of the device at those or any other conditions above those indicated in the operational sections of this specification is not intended. Exposure to maximum rating conditions for extended periods may affect device reliability.

### RECOMMENDED OPERATING CONDITIONS

Parameter	Sym.	Min.	Typ.	Max.	Unit	Conditions
Input Voltage (CP Mode)	$V_{LL}$	2.7	—	4.5	V	
High-level Input Voltage	$V_{IH}$	$0.8 V_{LL}$	—	$V_{LL}$	V	
Low-level Input Voltage	$V_{IL}$	0	—	$0.2 V_{LL}$	V	

### DC ELECTRICAL CHARACTERISTICS

**Electrical Specifications:** Over recommended operating supply voltages and temperatures; unless otherwise noted,  $T_J = 25^\circ\text{C}$ .

Parameter	Sym.	Min.	Typ.	Max.	Unit	Conditions
<b>POWER SUPPLY</b>						
Quiescent $V_{LL}$ Supply Current (EN = '0')	$I_{LLQ(off)}$	—	—	2	$\mu\text{A}$	
VLL Supply Current (EN = '1')	GATE = NC	—	—	1.5	mA	$f_{OSC} = 100 \text{ kHz}, V_{LL} = 4.5V$
	GATE = 300 pF	—	—	4		
VDD Supply Current (EN = '1')	GATE = NC	—	—	1	mA	$f_{OSC} = 100 \text{ kHz}, V_{DD} = 12.6V$
	GATE = 300 pF	—	—	2.5		
Quiescent VDD Supply Current (EN = '0')	$I_{DDQ(off)}$	—	—	2	$\mu\text{A}$	
High-level Logic Input Current	$I_{IH}$	—	—	1	$\mu\text{A}$	$V_{IH} = V_{LL}$
Low-level Logic Input Current	$I_{IL}$	—	—	-1	$\mu\text{A}$	$V_{IL} = 0V$
Gate Driver Output Voltage	GATE	$V_{LL} = 4.5V$ GATE = NC	10.2	—	12.3	V
		$V_{LL} = 2.7V$ GATE = NC	5	—	6.9	
Linear Regulator Output Voltage	$V_{LL(LDO)}$	3	—	3.6	V	

## AC ELECTRICAL CHARACTERISTICS

**Electrical Specifications:** Over recommended operating supply voltages and temperatures; unless otherwise noted  $T_J = 25^\circ\text{C}$ .

Parameter	Sym.	Min.	Typ.	Max.	Unit	Conditions	
<b>FEEDBACK (FB)</b>							
Internal Feed-back Reference Voltage	Accuracy	1.22	1.25	1.28	V	$T_A = -25$ to $85^\circ\text{C}$	
	Range	1.2	1.25	1.3			
Input Bias Current	$I_{\text{BIAS}}$	—	—	1	$\mu\text{A}$	EXT_REF is selected.	
External Reference Voltage	Range	0	—	$V_{\text{LL}}-1.4$	V	During EN positive triggering	
	Trigger INT Reference	0	—	0.12	V		
	Trigger EXT Reference	0.5	—	$V_{\text{LL}}-1.4$	V		
On-resistance, $R_{\text{DS}}$	FB_RTN	—	—	500	$\Omega$	$I_O = 2$ mA	
Breakdown Voltage, BV		—	—	13.5	V		
<b>GATE DRIVER OUTPUT (GATE)</b>							
Rise Time	$t_r$	—	—	36	ns	$C_L = 300$ pF, $V_{\text{DD}} = 12\text{V}$	
Fall Time	$t_f$	—	—	12	ns		
Pull-up Resistance	$V_{\text{DD}} = 5\text{V}$	$R_{\text{UP}}$	—	—	45	$\Omega$	$I_O = 20$ mA
	$V_{\text{DD}} = 12\text{V}$		—	—	30		$I_O = 50$ mA
Pull-down Resistance	$V_{\text{DD}} = 5\text{V}$	$R_{\text{DOWN}}$	—	—	15	$\Omega$	$I_O = 20$ mA
	$V_{\text{DD}} = 12\text{V}$		—	—	12		$I_O = 50$ mA
Oscillator Frequency	$f_{\text{GATE}}$	—	$\frac{1}{2} f_{\text{OSC}}$	—	kHz		
<b>CHARGE PUMP CONVERTER</b>							
Charge Pump Output Voltage	$V_{\text{DD}}$	5	$3 V_{\text{LL}}-1.8$	12.6	V	$2.7\text{V} \leq V_{\text{LL}} \leq 4.5\text{V}$ $C_{\text{CP1}} = 220$ nF $C_{\text{CP2}} = 220$ nF $C_{\text{CP3}} = 220$ nF	
Oscillator Frequency	Accuracy	$f_{\text{OSC}}$	170	195	220	kHz	$R_{\text{FREQ}} = 270$ k $\Omega$ , $V_{\text{LL}} = 3.3\text{V}$ Over $R_{\text{FREQ}}$ range
	Range		40	—	400		
Oscillator Frequency Tolerance	$\Delta f$	—	15	—	%	$50$ kHz $\leq f_{\text{OSC}} \leq 250$ kHz	
Duty Cycle	Accuracy	DC	86	87.5	90	%	$R_{\text{FREQ}} = 270$ k $\Omega$
	Range		—	0	—	%	$0 < V_{\text{CNTL}} \leq 0.18 V_{\text{LL}}$
			—	50	—	%	$0.22 V_{\text{LL}} < V_{\text{CNTL}} \leq 0.38 V_{\text{LL}}$
			—	62.5	—	%	$0.42 V_{\text{LL}} < V_{\text{CNTL}} \leq 0.58 V_{\text{LL}}$
			—	75	—	%	$0.62 V_{\text{LL}} < V_{\text{CNTL}} \leq 0.78 V_{\text{LL}}$
			—	87.5	—	%	$0.82 V_{\text{LL}} < V_{\text{CNTL}} \leq V_{\text{LL}}$
Duty Cycle Adjustment	$V_{\text{CONTROL}}$	0	—	$V_{\text{LL}}$	V	See <a href="#">Table 4-2</a> .	
Frequency Adjustment Resistor	$R_{\text{FREQ}}$	120k	—	1.2M	$\Omega$		
Maximum Charge Pump Output Resistance	Pull-up	$R_{\text{CP}}$	—	—	20	$\Omega$	$V_{\text{LL}} = 2.7\text{V}$ , $I_O = 10$ mA
	Pull-down		—	—	20		

# HV9150

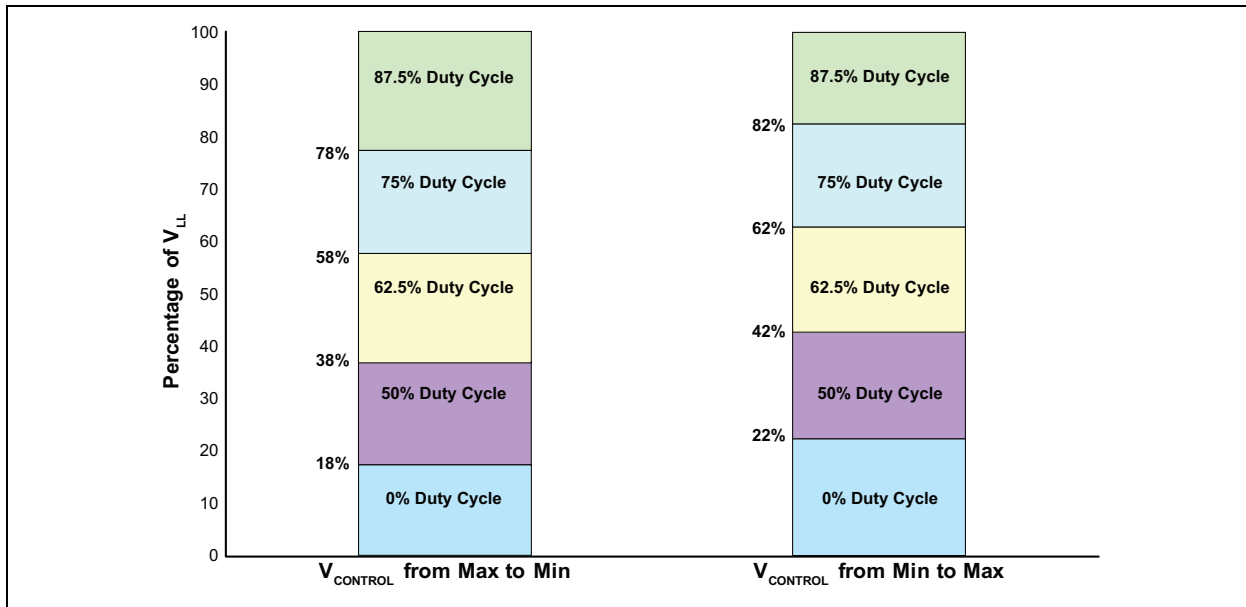
## AC ELECTRICAL CHARACTERISTICS (CONTINUED)

**Electrical Specifications:** Over recommended operating supply voltages and temperatures; unless otherwise noted  $T_J = 25^\circ\text{C}$ .

Parameter	Sym.	Min.	Typ.	Max.	Unit	Conditions
Output Ripple at $V_{DD}$	$V_{RIPPLE}$	—	—	100	mV	$2.7\text{V} \leq V_{LL} \leq 4.5\text{V}$ $f_{OSC} = 200\text{ kHz}$ $C_{CP1} = 220\text{ nF}$ $C_{CP2} = 220\text{ nF}$ $C_{CP3} = 220\text{ nF}$ $C_{GATE} = 300\text{ pF}$ $BW = 20\text{ MHz}$
<b>DELAY TIMER</b>						
Shutdown Delay Timer	$t_{DELAY}$	—	240	—	ms	$C_T = 1\text{ }\mu\text{F}$

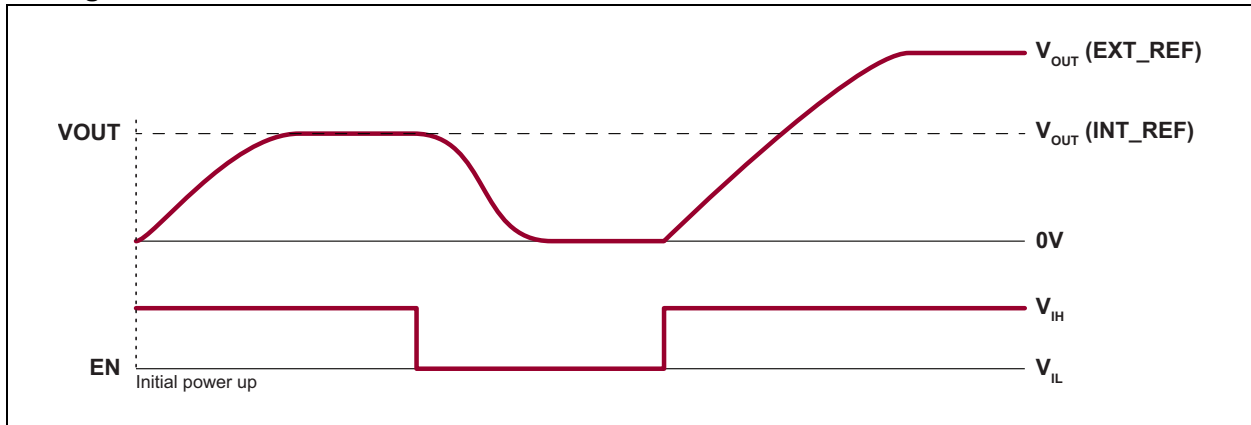
## TEMPERATURE SPECIFICATIONS

Parameter	Sym.	Min.	Typ.	Max.	Unit	Conditions
<b>TEMPERATURE RANGE</b>						
Operating Ambient Temperature	$T_A$	-25	—	+125	$^\circ\text{C}$	
Storage Temperature	$T_S$	-65	—	+150	$^\circ\text{C}$	
<b>PACKAGE THERMAL RESISTANCE</b>						
16-lead QFN	$\theta_{JA}$	—	33	—	$^\circ\text{C/W}$	

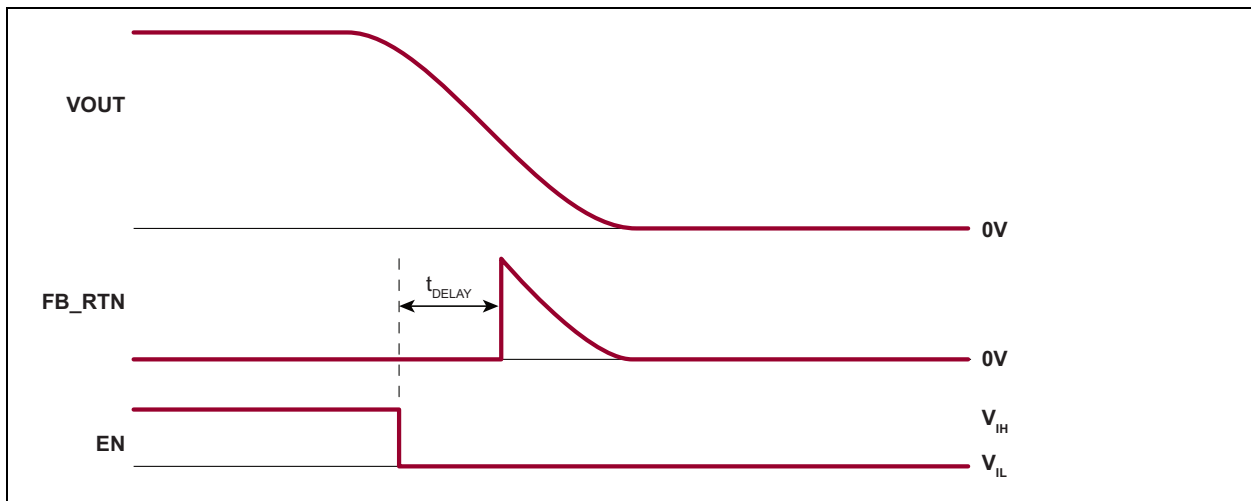


**FIGURE 1-1:** Duty Cycle Selection Hysteresis at  $V_{CONTROL}$  Pin at  $25^\circ\text{C}$ .

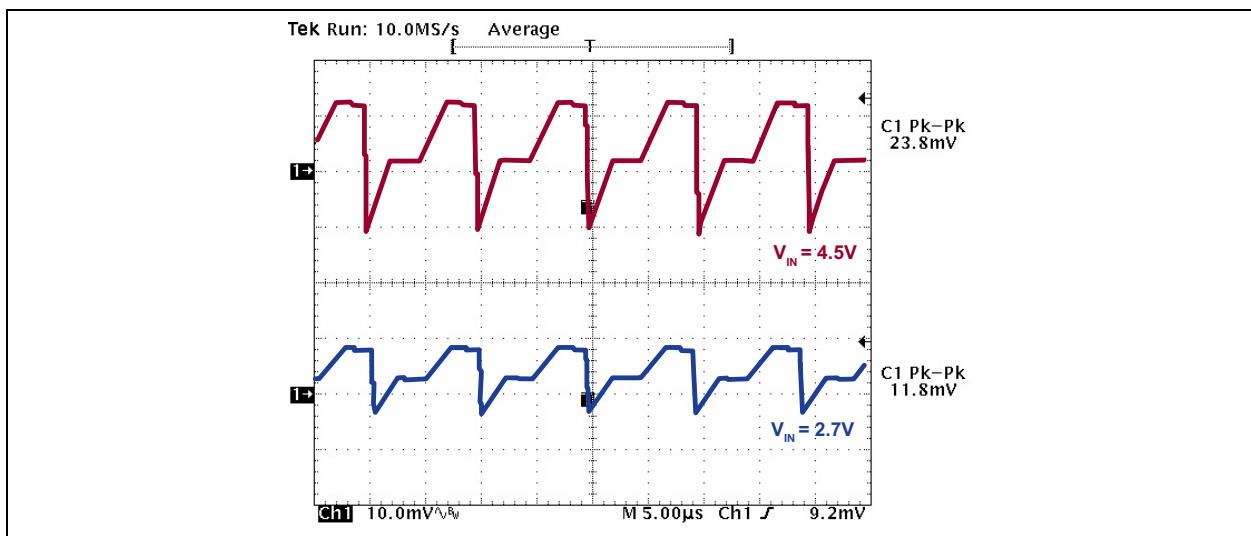
## Timing Waveforms



**FIGURE 1-2:** Enabling to use the External Voltage Reference.



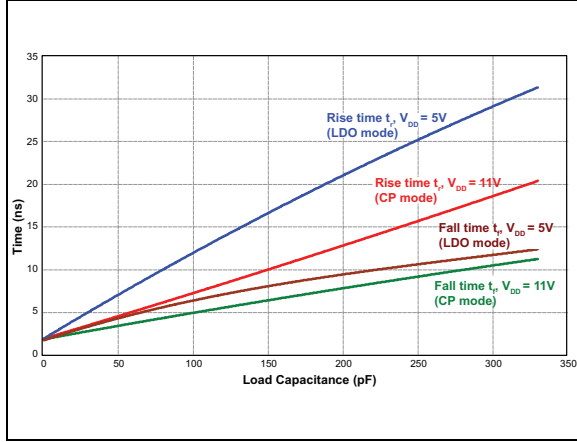
**FIGURE 1-3:** Delay Time at  $FB\_RTN$ .



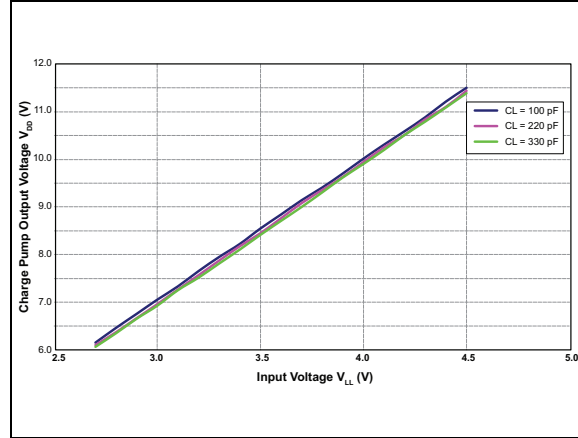
**FIGURE 1-4:** VCP Noise.

## 2.0 TYPICAL PERFORMANCE CURVES

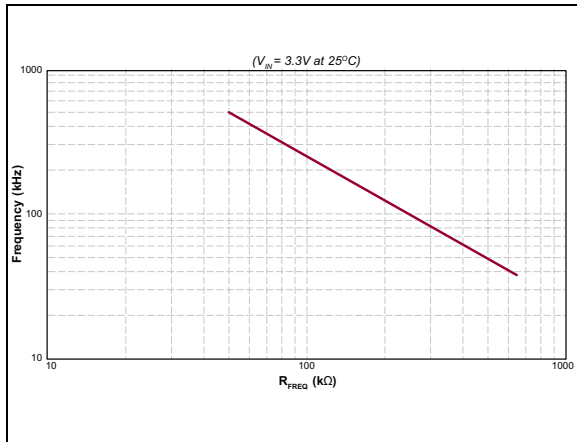
**Note:** The graphs and tables provided following this note are a statistical summary based on a limited number of samples and are provided for informational purposes only. The performance characteristics listed herein are not tested or guaranteed. In some graphs or tables, the data presented may be outside the specified operating range (e.g. outside specified power supply range) and therefore outside the warranted range.



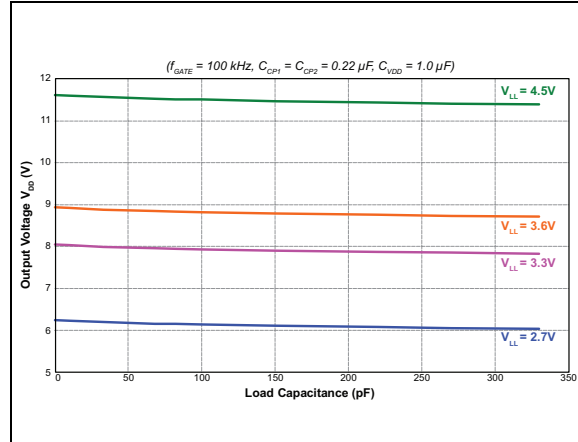
**FIGURE 2-1:** Gate Driver Rise Time ( $t_r$ ) and Fall Time ( $t_f$ ) vs. Load Capacitance at 25°C.



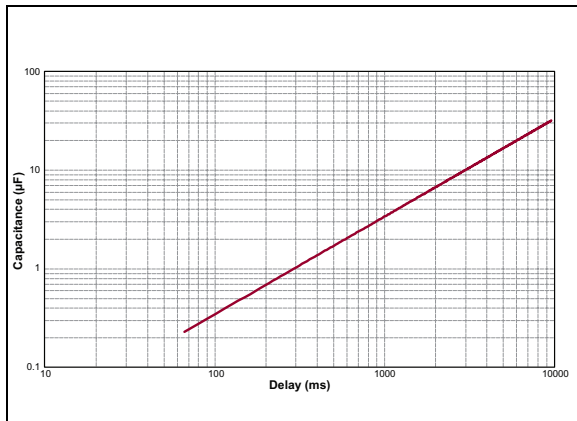
**FIGURE 2-4:** Charge Pump Output Voltage vs. Input Voltage at 25°C.



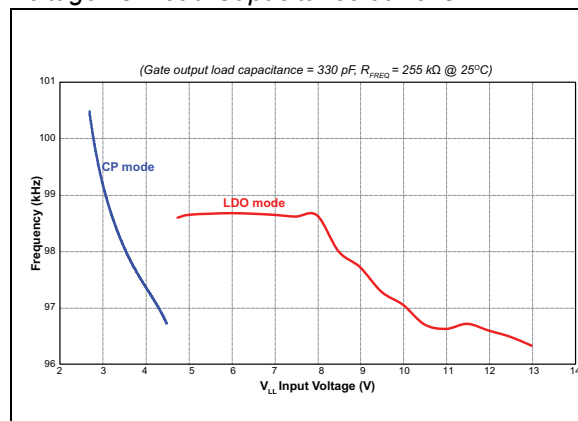
**FIGURE 2-2:**  $f_{GATE}$  vs.  $R_{FREQ}$ .



**FIGURE 2-5:** Charge Pump Output Voltage vs. Load Capacitance at 25°C.



**FIGURE 2-3:**  $C_T$  Capacitor Value vs. Delay Time at 25°C.



**FIGURE 2-6:** Gate Driver Switching Frequency vs.  $V_{LL}$  Input Voltage.



## 3.0 PIN DESCRIPTION

The details of the pins of HV9150 16-lead QFN are listed in [Table 3-1](#). Refer to [Package Type](#) for the pin locations.

**TABLE 3-1: PIN FUNCTION TABLE**

Pin Number	Pin Name	Description
1	VLL	Input supply voltage
2	GND	Ground connection
3	EN	Enable
4	$\overline{\text{CP\_EN}}$	Charge pump/LDO enable input
5	VCONTROL	Duty cycle adjustment voltage control input
6	FREQ_ADJ	Frequency adjustment
7	EXT_REF	External reference voltage input
8	CT	Timing capacitor
9	FB	Feedback input voltage
10	FB_RTN	Feedback return
11	GATE	Gate control output
12	VDD	Charge pump output voltage
13	CCP2+	Charge pump storage capacitor #2 plus terminal
14	CCP2-	Charge pump storage capacitor #2 minus terminal
15	CCP1+	Charge pump storage capacitor #1 plus terminal
16	CCP1-	Charge pump storage capacitor #1 minus terminal
Center Pad		Substrate connection (at ground potential)

## 4.0 FUNCTIONAL DESCRIPTION

Follow the steps in [Table 4-1](#) to power up and power down the HV9150.

**TABLE 4-1: POWER-UP AND POWER-DOWN SEQUENCE**

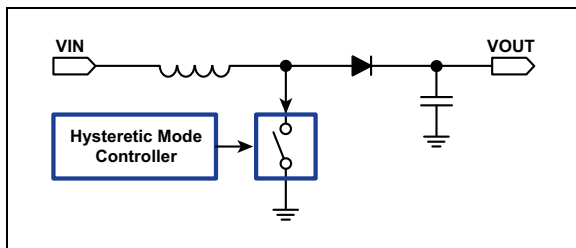
Power-up		Power-down	
Step	Description	Step	Description
1	Connect ground.	1	Remove all inputs.
2	Apply $V_{IN}$ .	2	Remove $V_{IN}$ .
3	Set all inputs to a known state.	3	Disconnect ground.

### 4.1 Hysteretic Mode Controller

A Hysteretic mode controller consists of an oscillator, a voltage reference, a comparator and a driver. Both the internal oscillator and the duty cycle of the gate driver are running at a fixed rate.

As this device is designed for a step-up conversion, a pulse train is used to control the switch of a classical switching boost converter. The pulse train is gated by the output of the comparator, which compares the feedback of the output voltage with the voltage reference.

If the output voltage reaches the target voltage, the comparator will turn off the pulse train. When the output voltage drops below the target voltage, the comparator will pass the pulse train to the switch and start the inductor charging cycle. The advantage of this Hysteretic mode controller is its stability and simple operation. The diagram in [Figure 4-1](#) shows a Hysteretic Mode controller and a classical boost converter.



**FIGURE 4-1:** A Hysteretic Mode Controller and a Classical Boost Converter.

### 4.2 Internal Oscillator

This device has an internal oscillator which generates the reference clock for the Hysteretic mode controller. The controller is running at half of the frequency of the internal oscillator. This oscillator is powered by the  $V_{LL}$  power supply pin. The frequency of the oscillator is set by the external resistor  $R_{FREQ}$ , and this frequency is inversely proportional to the value of  $R_{FREQ}$ . Its characteristic is shown in [Figure 2-2](#),  $f_{GATE}$  vs.  $R_{FREQ}$  diagram, where  $f_{GATE} = 1/2 f_{OSC}$ . See [Equation 4-1](#).

**EQUATION 4-1:**

$$f_{OSC} = \frac{1}{4 \times R_{FREQ} \times C}$$

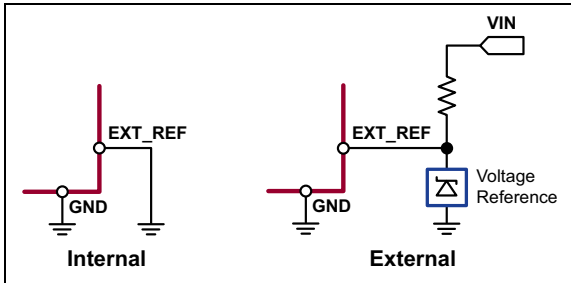
Where: C = 4.75 pF

### 4.3 Voltage Reference ( $V_{REF}$ )

The voltage reference is used by the comparator to compare it with the feedback voltage and the boost converter output. This device provides the options of using either its internal voltage reference or an external voltage reference.

The internal voltage reference provides a stable 1.25V with a tolerance of  $\pm 2.5\%$ . With the use of  $\pm 1\%$  tolerance feedback resistors, the output can be achieved with a tolerance of  $\pm 4.5\%$ . In order to use the internal voltage reference, the EXT\_REF pin must be connected to ground.

If the output voltage of the boost converter is required to have high precision and tight tolerance, the external voltage reference can be used to achieve that purpose. The external reference voltage must be between 0.5V and  $V_{LL} - 1.4V$  and connected to the EXT\_REF pin. A single low-to-high transition must be presented at the EN pin to trigger the device to select an external voltage reference. If no enable control signal is available in the application, this signal can be easily mimicked by a simple RC circuit. See [Figure 4-2](#).



**FIGURE 4-2:** Voltage Connection Reference.

## 4.4 Gate Driver (Gate)

The MOSFET gate driver of this controller is especially designed to drive the gate of the external MOSFET up to 12V. A high pulse voltage will help minimize the on-resistance of the external MOSFET transistor. A lower on-resistance improves the overall efficiency and heat dissipation.

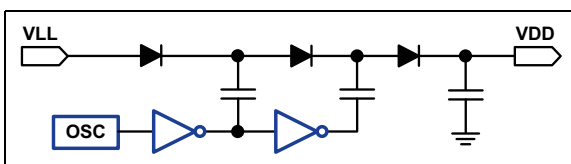
This gate driver is powered by the supply voltage  $V_{DD}$  which can be generated by either the internal charge pump converter (CP mode) or the external power supply (LDO mode), depending on the available voltage supply rail of the application. See [Typical Application Circuits](#).

## 4.5 Charge Pump Converter (CP Mode)

A 3X charge pump converter is integrated into this device to provide a 5V to 12V rail for the gate driver. (See [Figure 4-3](#).) It can be activated by setting CP\_EN to ground. A 3.3V supply is more common and easily available for digital logic systems. However, this voltage level is less desirable for driving a high-voltage MOSFET to obtain a lower on-resistance, which improves efficiency.

To reduce the number of supply rails used in the system, an internal two-stage charge pump converter is added, which can boost the 3.3V supply voltage to 8V. Compared to a 3.3V gate driver, an 8V gate driver output will substantially improve the on-resistance of the external MOSFET.

The charge pump input can operate with an input voltage from 2.7V to 4.5V. Its input and output are connected to the  $V_{LL}$  and  $V_{DD}$  pins, respectively.



**FIGURE 4-3:** A 3X Charge Pump Converter.

## 4.6 Linear Regulator (LDO Mode)

In some applications, efficiency may be a key factor, and higher voltage rails such as 5V, 6V, 9V or 12V may be available in the system. The internal charge pump converter cannot operate with these voltage levels because of the maximum output voltage limit of the charge pump converter. At the same time, these voltage levels are high enough to provide adequate supply for the gate driver.

Under this circumstance, an internal linear regulator is used to replace the charge pump converter. This linear regulator input can accept voltage from 5V to 12V and generate a 3.3V output to supply the internal circuit. This linear regulator can be activated by setting CP\_EN to  $V_{LL}$ .

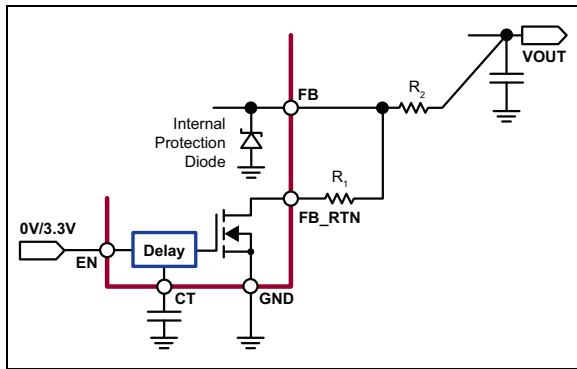
In a scenario when the device is operating in LDO mode and in Shutdown state ( $EN = '0'$ ), the voltage at  $V_{LL}$  is undefined. To wake up the controller device, a voltage above 2.7V has to be presented at the enable pin (EN).

## 4.7 FB Ground Return Switch (FB\_RTN)

Any DC/DC controller requires feedback from the output to monitor its operation so that it can regulate its output accordingly. A simple resistor network is used in conjunction with a feedback ground switch as a feedback path. The purpose of this feedback ground switch is to save power consumed by the feedback resistor network when the controller is disabled. This function is quite useful for power saving, especially for battery-operated applications.

## 4.8 Shutdown Timer and Timing Capacitor ( $C_T$ )

A shutdown timer is also integrated into the controller for safety purposes. When the controller shuts down from its normal operation, the converter's initial output is still at its high level. If the feedback ground return switch is disabled at the same time, a current path is created from the output via the feedback resistor and the internal protection clamping diode at the FB pin. (See [Figure 4-4](#).) Depending upon the value of the FB resistor, this momentarily conducting current can be high enough to damage this clamping diode. To avoid this potential problem, a timer is added to the disable function to keep the feedback ground switch to on position for a short period of time. This on-time duration is controlled by an external capacitor  $C_T$ . The larger the capacitor value is, the longer the on-time is. Its characteristic is shown in [Figure 2-3](#).



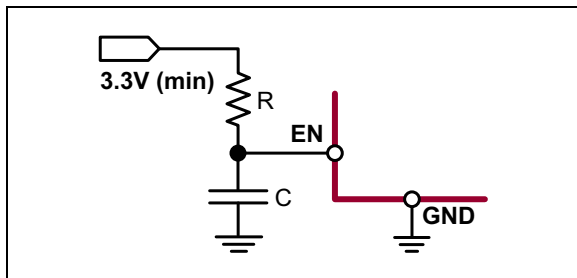
**FIGURE 4-4:** Internal Protection Diode at FB Pin.

## 4.9 Hysteretic Controller Enable

The controller enable pin (EN), serves two main purposes. The most obvious function is to turn on and off the controller, and the other function is to act as a trigger to activate the device to accept external voltage reference.

For any applications requiring a highly precise voltage reference, an external voltage reference should be used. To activate the device to accept the external voltage reference, a low-to-high transition has to appear at the EN pin while the voltage at the EXT\_REF pin is above 0.5V.

If the system lacks enable function control, an RC circuit can be used to mimic this function to allow the external voltage reference. Refer to Figure 4-5.



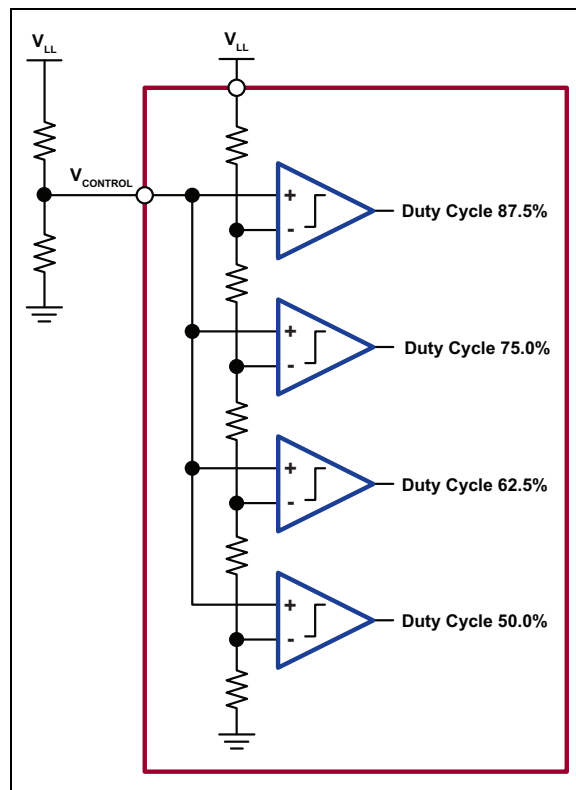
**FIGURE 4-5:** Simple RC Circuit for EN Pin.

## 4.10 Duty Cycle Control ( $V_{CONTROL}$ )

The input voltage at the  $V_{CONTROL}$  pin manages the duty cycle of the internal oscillator output to the gate driver. All internal comparators are powered by the  $V_{LL}$  supply and all their input threshold voltages are referenced to  $V_{LL}$  voltage. A voltage divider formed by the two external resistors shown in Figure 4-6 can be adjusted accordingly to select the desired duty cycle of the pulse signal to the gate driver. See Table 4-2.

**TABLE 4-2: DUTY CYCLE SELECTION**

$V_{CONTROL}$	Duty Cycle
$0 V_{LL}$ to $0.18 V_{LL}$	0%
$0.22 V_{LL}$ to $0.38 V_{LL}$	50%
$0.42 V_{LL}$ to $0.58 V_{LL}$	62.5%
$0.62 V_{LL}$ to $0.78 V_{LL}$	75%
$0.82 V_{LL}$ to $1 V_{LL}$	87.5%



**FIGURE 4-6:** Duty Cycle Control Circuit.

## 4.11 Design Procedure

There are several parameters that a user needs to consider for the DC/DC converter design. The input voltage, output voltage and output power requirement are usually defined at the beginning. The other parameters that may be included are: operating frequency, inductor value, duty cycle and the on-resistance of the MOSFET. There is some degree of flexibility in deciding the values of these parameters. The following provides the user a general design approach:

### 4.11.1 STEP 1

Since this DC/DC controller device is operating in a Discontinuous Conduction mode, determine the inductance and the switching frequency with [Equation 4-2](#).

#### EQUATION 4-2:

Given:

D = Duty cycle

R = Load resistance of the high voltage output

$V_i$  = Minimum input voltage

$V_o$  = Output voltage

Unknown:

L = Inductance

$f_{GATE}$  = Driver switching frequency

Where: 
$$V_o = \frac{V_i}{2} \times \left( 1 + \sqrt{1 + \frac{4D^2}{K}} \right)$$

$$K = \frac{2 \times L \times f_{GATE}}{R}$$

The maximum duty cycle can be computed with [Equation 4-3](#).

#### EQUATION 4-3:

$$D_{MAX} = 1 - \frac{V_i}{V_o}$$

Then, the user can select any duty cycle less than  $D_{MAX}$ . Choosing the largest possible setting is highly recommended.

To compensate for the limited efficiency, the user can add the efficiency factor into the load resistance R. With the above equation, the product of L and  $f_{GATE}$  is determined. The product will also limit the design.

### 4.11.2 STEP 2

The standard inductor is usually sold in an incremental inductance value, for example, 10  $\mu$ H, 22  $\mu$ H, 33  $\mu$ H or 47  $\mu$ H. The user can choose the inductance based on the size of the inductor, the peak current, the maximum operating frequency and the DC resistance. After the value of L is decided, the gate driver switching frequency can be computed. The required  $R_{FREQ}$  resistance can be found in the  $f_{GATE}$  vs.  $R_{FREQ}$  diagram. (See [Figure 2-2](#).) Next, the user may check the peak current of the inductor with [Equation 4-4](#). The saturation current of the inductor must be larger than  $I_{PEAK}$ .

#### EQUATION 4-4:

$$I_{PEAK} = \frac{V_i \times D}{L \times f_{GATE}}$$

### 4.11.3 STEP 3

The most important factors in determining the MOSFET are the breakdown voltage, the current capability, the on-resistance, the minimum  $V_{GS}$  threshold voltage and the input capacitance.

The HV9150 gate driver is designed to drive a maximum of 300 pF capacitive load. Therefore, the maximum input capacitance of the external MOSFET should be less than 300 pF. The minimum breakdown voltage must be larger than the required DC/DC converter output voltage. If the breakdown voltage is too low, the output will never reach the required voltage output. A MOSFET with high on-resistance will limit the peak current charging the inductor. The user can use a simple RL charging circuit equation to determine its final charging current. See [Equation 4-5](#).

#### EQUATION 4-5:

$$I_L = \frac{V_i}{R_{ON}} \left[ 1 - \exp\left(-\frac{D}{f_{GATE}} \times \frac{R_{ON}}{L}\right) \right]$$

It is recommended that the calculated value of  $I_L$  is within 95% of the  $I_{PEAK}$  calculated in [Equation 4-4](#). An on-resistance of less than 1 $\Omega$  is usually a good starting point.

If the final circuit is short on the output current capability, the user can do any or all of the following to boost the output:

1. Increase the duty cycle.
2. Decrease the  $f_{GATE}$ .
3. Use a MOSFET with lower on-resistance.

# HV9150

---

NOTES:

## 5.0 PACKAGE MARKING INFORMATION

### 5.1 Packaging Information

16-lead QFN

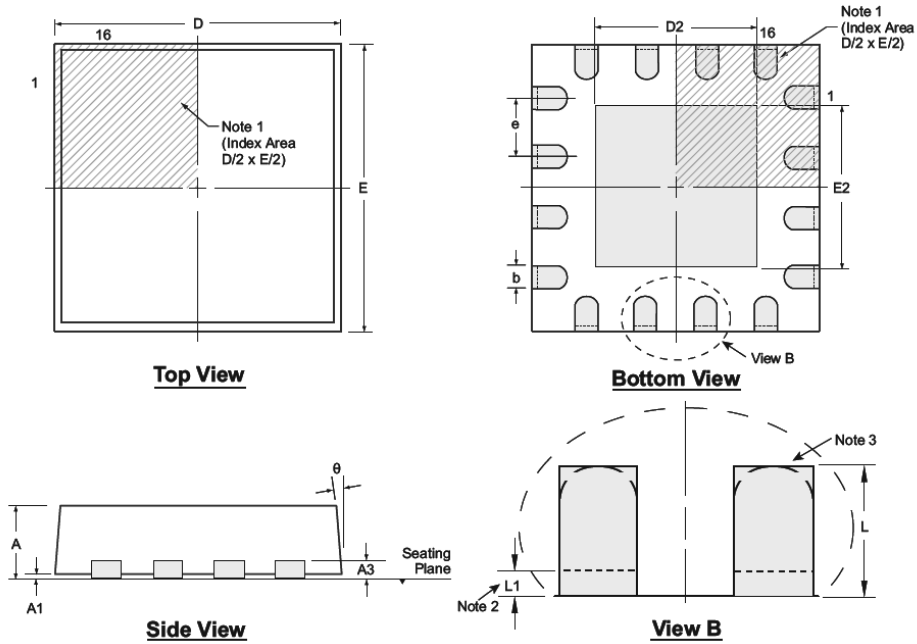
XXXXX
XYWW
NNN

Example

H15
0724
485

<b>Legend:</b>	XX...X	Product Code or Customer-specific information
	Y	Year code (last digit of calendar year)
	YY	Year code (last 2 digits of calendar year)
	WW	Week code (week of January 1 is week '01')
	NNN	Alphanumeric traceability code
	(e3)	Pb-free JEDEC® designator for Matte Tin (Sn)
	*	This package is Pb-free. The Pb-free JEDEC designator (e3) can be found on the outer packaging for this package.
<b>Note:</b>	In the event the full Microchip part number cannot be marked on one line, it will be carried over to the next line, thus limiting the number of available characters for product code or customer-specific information. Package may or not include the corporate logo.	

## 16-Lead QFN Package Outline (K6) 3.00x3.00mm body, 1.00mm height (max), 0.50mm pitch



Note: For the most current package drawings, see the Microchip Packaging Specification at [www.microchip.com/packaging](http://www.microchip.com/packaging).

**Notes:**

1. A Pin 1 identifier must be located in the index area indicated. The Pin 1 identifier can be: a molded mark/identifier; an embedded metal marker; or a printed indicator.
2. Depending on the method of manufacturing, a maximum of 0.15mm pullback (L1) may be present.
3. The inner tip of the lead may be either rounded or square.

Symbol	A	A1	A3	b	D	D2	E	E2	e	L	L1	$\theta$	
Dimension (mm)	MIN	0.80	0.00	0.20 REF	0.18	2.85*	1.50	2.85*	1.50	0.50 BSC	0.20†	0.00	0°
	NOM	0.90	0.02		0.25	3.00	1.65	3.00	1.65		0.30†	-	-
	MAX	1.00	0.05		0.30	3.15*	1.80	3.15*	1.80		0.45	0.15	14°

JEDEC Registration MO-220, Variation VEED-4, Issue K, June 2006.

\* This dimension is not specified in the JEDEC drawing.

† This dimension differs from the JEDEC drawing.

Drawings not to scale.



## APPENDIX A: REVISION HISTORY

### Revision B (March 2019)

- Updated [AC Electrical Characteristics](#) table.

### Revision A (February 2017)

- Converted Supertex Doc# DSFP-HV9150 to Microchip DS20005689B
- Changed the quantity of the 16-lead QFN K6 package from 3000/Reel to 3300/Reel
- Made minor text changes throughout the document

# HV9150

## PRODUCT IDENTIFICATION SYSTEM

To order or obtain information, e.g., on pricing or delivery, contact your local Microchip representative or sales office.

<u>PART NO.</u>	<u>XX</u>	-	<u>X</u>	-	<u>X</u>
Device	Package Options		Environmental		Media Type
Device:	HV9150	=	High-Voltage Output Hysteretic-Mode Step-Up DC/DC Controller		
Package:	K6	=	16-lead VQFN		
Environmental:	G	=	Lead (Pb)-free/RoHS-compliant Package		
Media Type:	(blank)	=	3300/Reel for a K6 Package		

**Example:**  
a) HV9150K6-G: High-Voltage Output Hysteretic-Mode Step-Up DC/DC Controller, 16-lead VQFN Package, 3300/Reel

---

---

**Note the following details of the code protection feature on Microchip devices:**

- Microchip products meet the specification contained in their particular Microchip Data Sheet.
- Microchip believes that its family of products is one of the most secure families of its kind on the market today, when used in the intended manner and under normal conditions.
- There are dishonest and possibly illegal methods used to breach the code protection feature. All of these methods, to our knowledge, require using the Microchip products in a manner outside the operating specifications contained in Microchip's Data Sheets. Most likely, the person doing so is engaged in theft of intellectual property.
- Microchip is willing to work with the customer who is concerned about the integrity of their code.
- Neither Microchip nor any other semiconductor manufacturer can guarantee the security of their code. Code protection does not mean that we are guaranteeing the product as “unbreakable.”

Code protection is constantly evolving. We at Microchip are committed to continuously improving the code protection features of our products. Attempts to break Microchip's code protection feature may be a violation of the Digital Millennium Copyright Act. If such acts allow unauthorized access to your software or other copyrighted work, you may have a right to sue for relief under that Act.

---

Information contained in this publication regarding device applications and the like is provided only for your convenience and may be superseded by updates. It is your responsibility to ensure that your application meets with your specifications. MICROCHIP MAKES NO REPRESENTATIONS OR WARRANTIES OF ANY KIND WHETHER EXPRESS OR IMPLIED, WRITTEN OR ORAL, STATUTORY OR OTHERWISE, RELATED TO THE INFORMATION, INCLUDING BUT NOT LIMITED TO ITS CONDITION, QUALITY, PERFORMANCE, MERCHANTABILITY OR FITNESS FOR PURPOSE. Microchip disclaims all liability arising from this information and its use. Use of Microchip devices in life support and/or safety applications is entirely at the buyer's risk, and the buyer agrees to defend, indemnify and hold harmless Microchip from any and all damages, claims, suits, or expenses resulting from such use. No licenses are conveyed, implicitly or otherwise, under any Microchip intellectual property rights unless otherwise stated.

*Microchip received ISO/TS-16949:2009 certification for its worldwide headquarters, design and wafer fabrication facilities in Chandler and Tempe, Arizona; Gresham, Oregon and design centers in California and India. The Company's quality system processes and procedures are for its PIC® MCUs and dsPIC® DSCs, KEELOQ® code hopping devices, Serial EEPROMs, microperipherals, nonvolatile memory and analog products. In addition, Microchip's quality system for the design and manufacture of development systems is ISO 9001:2000 certified.*

**QUALITY MANAGEMENT SYSTEM  
CERTIFIED BY DNV  
= ISO/TS 16949 =**

### **Trademarks**

The Microchip name and logo, the Microchip logo, AnyRate, AVR, AVR logo, AVR Freaks, BitCloud, chipKIT, chipKIT logo, CryptoMemory, CryptoRF, dsPIC, FlashFlex, flexPWR, Helder, JukeBlox, KeeLoq, Klear, LANCheck, LINK MD, maXStylus, maXTouch, MediaLB, megaAVR, MOST, MOST logo, MPLAB, OptoLyzer, PIC, picoPower, PICSTART, PIC32 logo, Prochip Designer, QTouch, SAM-BA, SpyNIC, SST, SST Logo, SuperFlash, tinyAVR, UNI/O, and XMEGA are registered trademarks of Microchip Technology Incorporated in the U.S.A. and other countries.

ClockWorks, The Embedded Control Solutions Company, EtherSynch, Hyper Speed Control, HyperLight Load, IntellIMOS, mTouch, Precision Edge, and Quiet-Wire are registered trademarks of Microchip Technology Incorporated in the U.S.A.

Adjacent Key Suppression, AKS, Analog-for-the-Digital Age, Any Capacitor, AnyIn, AnyOut, BodyCom, CodeGuard, CryptoAuthentication, CryptoAutomotive, CryptoCompanion, CryptoController, dsPICDEM, dsPICDEM.net, Dynamic Average Matching, DAM, ECAN, EtherGREEN, In-Circuit Serial Programming, ICSP, INICnet, Inter-Chip Connectivity, JitterBlocker, KlearNet, KlearNet logo, memBrain, Mindi, MiWi, motorBench, MPASM, MPF, MPLAB Certified logo, MPLIB, MPLINK, MultiTRAK, NetDetach, Omniscient Code Generation, PICDEM, PICDEM.net, PICkit, PICtail, PowerSmart, PureSilicon, QMatrix, REAL ICE, Ripple Blocker, SAM-ICE, Serial Quad I/O, SMART-I.S., SQI, SuperSwitcher, SuperSwitcher II, Total Endurance, TSHARC, USBCheck, VariSense, ViewSpan, WiperLock, Wireless DNA, and ZENA are trademarks of Microchip Technology Incorporated in the U.S.A. and other countries.

SQTP is a service mark of Microchip Technology Incorporated in the U.S.A.

Silicon Storage Technology is a registered trademark of Microchip Technology Inc. in other countries.

GestIC is a registered trademark of Microchip Technology Germany II GmbH & Co. KG, a subsidiary of Microchip Technology Inc., in other countries.

All other trademarks mentioned herein are property of their respective companies.

© 2019, Microchip Technology Incorporated, All Rights Reserved.

ISBN: 978-1-5224-4311-7



# MICROCHIP

## Worldwide Sales and Service

### AMERICAS

**Corporate Office**  
2355 West Chandler Blvd.  
Chandler, AZ 85224-6199  
Tel: 480-792-7200  
Fax: 480-792-7277  
Technical Support:  
<http://www.microchip.com/support>  
Web Address:  
[www.microchip.com](http://www.microchip.com)

#### Atlanta

Duluth, GA  
Tel: 678-957-9614  
Fax: 678-957-1455

#### Austin, TX

Tel: 512-257-3370

#### Boston

Westborough, MA  
Tel: 774-760-0087  
Fax: 774-760-0088

#### Chicago

Itasca, IL  
Tel: 630-285-0071  
Fax: 630-285-0075

#### Dallas

Addison, TX  
Tel: 972-818-7423  
Fax: 972-818-2924

#### Detroit

Novi, MI  
Tel: 248-848-4000

#### Houston, TX

Tel: 281-894-5983

#### Indianapolis

Noblesville, IN  
Tel: 317-773-8323  
Fax: 317-773-5453  
Tel: 317-536-2380

#### Los Angeles

Mission Viejo, CA  
Tel: 949-462-9523  
Fax: 949-462-9608  
Tel: 951-273-7800

#### Raleigh, NC

Tel: 919-844-7510

#### New York, NY

Tel: 631-435-6000

#### San Jose, CA

Tel: 408-735-9110  
Tel: 408-436-4270

#### Canada - Toronto

Tel: 905-695-1980  
Fax: 905-695-2078

### ASIA/PACIFIC

**Australia - Sydney**  
Tel: 61-2-9868-6733

**China - Beijing**  
Tel: 86-10-8569-7000

**China - Chengdu**  
Tel: 86-28-8665-5511

**China - Chongqing**  
Tel: 86-23-8980-9588

**China - Dongguan**  
Tel: 86-769-8702-9880

**China - Guangzhou**  
Tel: 86-20-8755-8029

**China - Hangzhou**  
Tel: 86-571-8792-8115

**China - Hong Kong SAR**  
Tel: 852-2943-5100

**China - Nanjing**  
Tel: 86-25-8473-2460

**China - Qingdao**  
Tel: 86-532-8502-7355

**China - Shanghai**  
Tel: 86-21-3326-8000

**China - Shenyang**  
Tel: 86-24-2334-2829

**China - Shenzhen**  
Tel: 86-755-8864-2200

**China - Suzhou**  
Tel: 86-186-6233-1526

**China - Wuhan**  
Tel: 86-27-5980-5300

**China - Xian**  
Tel: 86-29-8833-7252

**China - Xiamen**  
Tel: 86-592-2388138

**China - Zhuhai**  
Tel: 86-756-3210040

### ASIA/PACIFIC

**India - Bangalore**  
Tel: 91-80-3090-4444

**India - New Delhi**  
Tel: 91-11-4160-8631

**India - Pune**  
Tel: 91-20-4121-0141

**Japan - Osaka**  
Tel: 81-6-6152-7160

**Japan - Tokyo**  
Tel: 81-3-6880-3770

**Korea - Daegu**  
Tel: 82-53-744-4301

**Korea - Seoul**  
Tel: 82-2-554-7200

**Malaysia - Kuala Lumpur**  
Tel: 60-3-7651-7906

**Malaysia - Penang**  
Tel: 60-4-227-8870

**Philippines - Manila**  
Tel: 63-2-634-9065

**Singapore**  
Tel: 65-6334-8870

**Taiwan - Hsin Chu**  
Tel: 886-3-577-8366

**Taiwan - Kaohsiung**  
Tel: 886-7-213-7830

**Taiwan - Taipei**  
Tel: 886-2-2508-8600

**Thailand - Bangkok**  
Tel: 66-2-694-1351

**Vietnam - Ho Chi Minh**  
Tel: 84-28-5448-2100

### EUROPE

**Austria - Wels**  
Tel: 43-7242-2244-39  
Fax: 43-7242-2244-393

**Denmark - Copenhagen**  
Tel: 45-4450-2828  
Fax: 45-4485-2829

**Finland - Espoo**  
Tel: 358-9-4520-820

**France - Paris**  
Tel: 33-1-69-53-63-20  
Fax: 33-1-69-30-90-79

**Germany - Garching**  
Tel: 49-8931-9700

**Germany - Haan**  
Tel: 49-2129-3766400

**Germany - Heilbronn**  
Tel: 49-7131-67-3636

**Germany - Karlsruhe**  
Tel: 49-721-625370

**Germany - Munich**  
Tel: 49-89-627-144-0  
Fax: 49-89-627-144-44

**Germany - Rosenheim**  
Tel: 49-8031-354-560

**Israel - Ra'anana**  
Tel: 972-9-744-7705

**Italy - Milan**  
Tel: 39-0331-742611  
Fax: 39-0331-466781

**Italy - Padova**  
Tel: 39-049-7625286

**Netherlands - Drunen**  
Tel: 31-416-690399  
Fax: 31-416-690340

**Norway - Trondheim**  
Tel: 47-7288-4388

**Poland - Warsaw**  
Tel: 48-22-3325737

**Romania - Bucharest**  
Tel: 40-21-407-87-50

**Spain - Madrid**  
Tel: 34-91-708-08-90  
Fax: 34-91-708-08-91

**Sweden - Gothenberg**  
Tel: 46-31-704-60-40

**Sweden - Stockholm**  
Tel: 46-8-5090-4654

**UK - Wokingham**  
Tel: 44-118-921-5800  
Fax: 44-118-921-5820

# Mouser Electronics

Authorized Distributor

Click to View Pricing, Inventory, Delivery & Lifecycle Information:

[Microchip:](#)

[HV9150K6-G](#)

## Данный компонент на территории Российской Федерации

### Вы можете приобрести в компании MosChip.

Для оперативного оформления запроса Вам необходимо перейти по данной ссылке:

<http://moschip.ru/get-element>

Вы можете разместить у нас заказ для любого Вашего проекта, будь то серийное производство или разработка единичного прибора.

В нашем ассортименте представлены ведущие мировые производители активных и пассивных электронных компонентов.

Нашей специализацией является поставка электронной компонентной базы двойного назначения, продукции таких производителей как XILINX, Intel (ex.ALTERA), Vicor, Microchip, Texas Instruments, Analog Devices, Mini-Circuits, Amphenol, Glenair.

Сотрудничество с глобальными дистрибьюторами электронных компонентов, предоставляет возможность заказывать и получать с международных складов практически любой перечень компонентов в оптимальные для Вас сроки.

На всех этапах разработки и производства наши партнеры могут получить квалифицированную поддержку опытных инженеров.

Система менеджмента качества компании отвечает требованиям в соответствии с ГОСТ Р ИСО 9001, ГОСТ РВ 0015-002 и ЭС РД 009

### Офис по работе с юридическими лицами:

105318, г.Москва, ул.Щербаковская д.3, офис 1107, 1118, ДЦ «Щербаковский»

Телефон: +7 495 668-12-70 (многоканальный)

Факс: +7 495 668-12-70 (доб.304)

E-mail: [info@moschip.ru](mailto:info@moschip.ru)

Skype отдела продаж:

moschip.ru

moschip.ru\_4

moschip.ru\_6

moschip.ru\_9