

Spezifikation für Freigabe / specification for release

Kunde / customer :
 Artikelnummer / part number :

749052012



Bezeichnung : LAN-Übertrager WE-LAN 10G
 description : LAN-Transformer WE-LAN 10G

DATUM / DATE : 2015-05-21

A Mechanische Abmessungen / dimensions :

10G BaseT 4PPoE

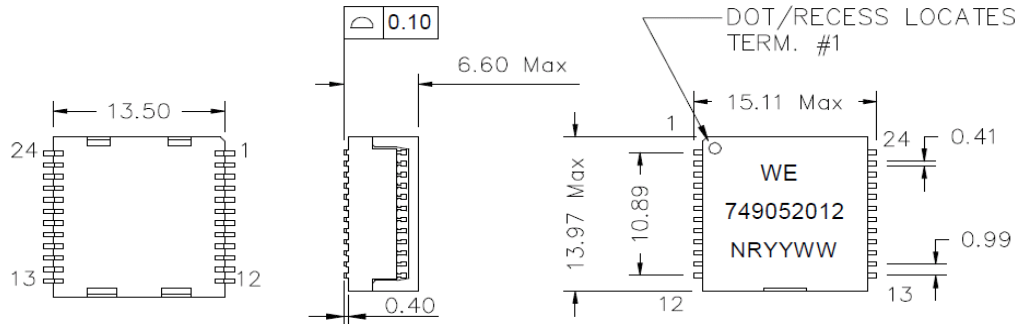

B Elektrische Eigenschaften / electrical properties :

Eigenschaften / properties	Testbedingungen / test conditions		Wert / value	Einheit / unit	tol.
Induktivität / Inductance	100kHz / 100mV @ 15mA DC-Bias	OCL	120	µH	min.
Übersetzungsverhältnis / Turns ratio	100kHz / 100mV	TR	1:1		±2%
Insertion Loss	100kHz-1MHz	IL	-3,0	dB	max.
	1MHz-250MHz		-1,00		
	250MHz-500MHz		-3,0		
Return Loss	1-40MHz	RL	-20,0	dB	min.
	100MHz		-16,0		
	200MHz		-13,0		
	250MHz		-11,2		
	400MHz		-10,0		
Common to Differential Mode Rejection	1MHz-100MHz	CDMR	-35,0	dB	min.
	100MHz-300MHz		-30,0		
	300MHz-500MHz		-25,0		
Common to Common Mode Rejection	1MHz-100MHz	CMRR	-35,0	dB	min.
	100MHz-250MHz		-30,0		
	250MHz-500MHz		-25,0		
Crosstalk	1MHz-100MHz	CT	-40,0	dB	min.
	100MHz-500MHz		-30,0		

C Lötpad / soldering spec. :

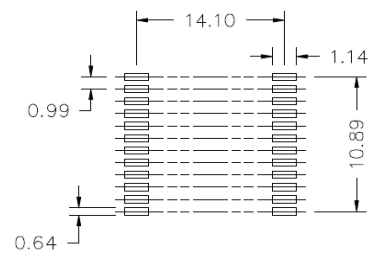

D Prüfgeräte / test equipment :

Agilent E5071C

E Testbedingungen / test conditions :

Luftfeuchtigkeit / Humidity: 33%
 Umgebungstemperatur / Temperature: +25°C

F Werkstoffe & Zulassungen / material & approvals :

Basismaterial / Base material: Ferrit / Ferrite
 Draht / Wire: 0UEW/Y 180
 Kontaktmaterial / Contact plating: Cu-Ni-Sn
 Gehäuse / Case: UL94V-0
 Verguss / Potting: UL94V-0

G Eigenschaften / general specifications :

Betriebstemp. / Operating temperature: 0°C - +70°C
 Hochspannungsprüfung / Hipot test: 1500Vrms 1min.
 Feuchteempfindlichkeit: MSL 1 / Humidity class: MSL 1

Freigabe erteilt / general release:	Kunde / customer		
.....		
Datum / date	Unterschrift / signature		
.....	Würth Elektronik		
.....		
Geprüft / checked	Kontrolliert / approved		
.....	Name	Änderung / modification	Datum / date
	JLiu	Revision 02	2015-05-21
	JLiu	Revision 01	2015-04-27
	JLiu	Revision 00	2015-04-13

Würth Elektronik eiSos GmbH & Co.KG

D-74638 Waldenburg · Max-Eyth-Straße 1 - 3 · Germany · Telefon (+49) (0) 7942 - 945 - 0 · Telefax (+49) (0) 7942 - 945 - 400
 http://www.we-online.com

Spezifikation für Freigabe / specification for release

Kunde / customer :
 Artikelnummer / part number : **749052012**
 Bezeichnung : **LAN-Übertrager WE-LAN 10G**
 description : **LAN-Transformer WE-LAN 10G**



DATUM / DATE : 2015-05-21

H PoE Eigenschaften :

Designed für Applikationen bis 30W @57VDC
 wenn zwei Kanäle bestromt
 Designed für Applikationen bis 60W @57VDC
 wenn alle vier Kanäle bestromt

H PoE Specifications :

Designed to support applications up to 30W @57VDC
 when using two channels
 Designed to support applications up to 60W @57VDC
 when using four channels

I Schaltbild / Schematics :

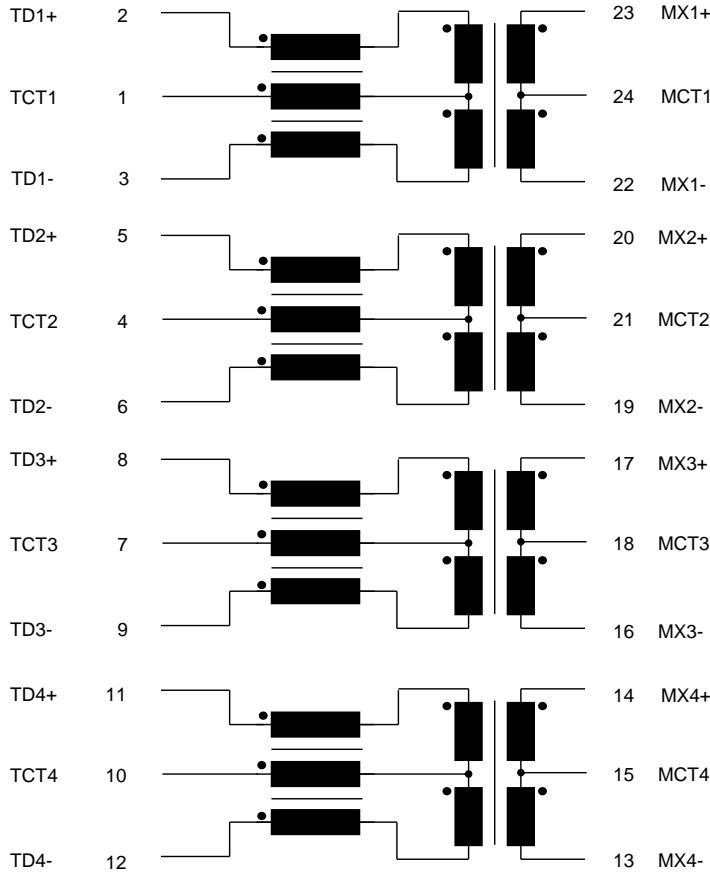

Freigabe erteilt / general release:	Kunde / customer			
Datum / date	Unterschrift / signature			
	Würth Elektronik	JLiu	Revision 02	2015-05-21
		JLiu	Revision 01	2015-04-27
		JLiu	Revision 00	2015-04-13
Geprüft / checked	Kontrolliert / approved	Name	Änderung / modification	Datum / date

This electronic component has been designed and developed for usage in general electronic equipment. Before incorporating this component into any equipment where higher safety and reliability is especially required or if there is the possibility of direct damage or injury to human body, for example in the range of aerospace, aviation, nuclear control, submarine, transportation, (automotive control, train control, ship control), transportation signal, disaster prevention, medical, public information network etc, Würth Elektronik eiSos GmbH must be informed before the design-in stage. In addition, sufficient reliability evaluation checks for safety must be performed on every electronic component which is used in electrical circuits that require high safety and reliability functions or performance.

Würth Elektronik eiSos GmbH & Co.KG

D-74638 Waldenburg · Max-Eyth-Straße 1 - 3 · Germany · Telefon (+49) (0) 7942 - 945 - 0 · Telefax (+49) (0) 7942 - 945 - 400
<http://www.we-online.com>

Spezifikation für Freigabe / specification for release

Kunde / customer :

Artikelnummer / part number :

749052012

Bezeichnung :

LAN-Übertrager WE-LAN 10G

description :

LAN-Transformer WE-LAN 10G



DATUM / DATE : 2015-05-21

J Rollenspezifikation / tape and reel specification :

Gurtspezifikation / Tape specification:

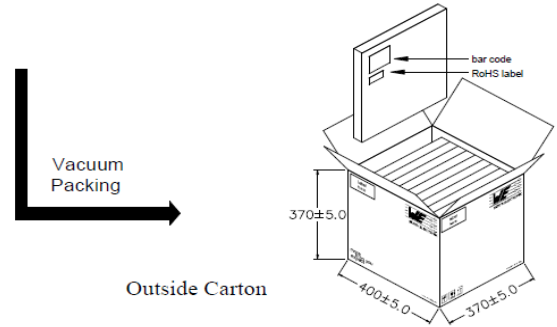
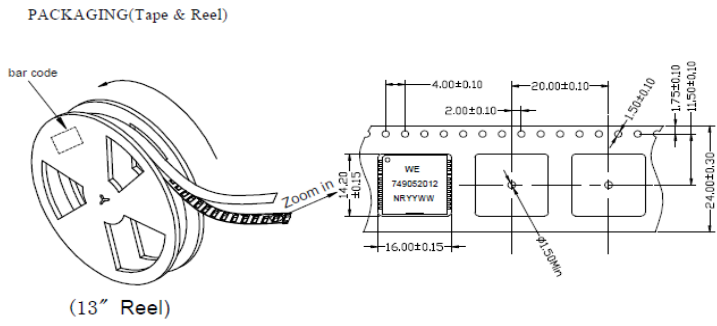

Vacuum
Packing

PACKING QUANTITY:
450pcs Finished Goods / Reel
10 Reel (4500pcs Finished Goods) / Carton

Freigabe erteilt / general release:	Kunde / customer			
Datum / date	Unterschrift / signature			
	Würth Elektronik	JLiu	Revision 02	2015-05-21
		JLiu	Revision 01	2015-04-27
		JLiu	Revision 00	2015-04-13
Geprüft / checked	Kontrolliert / approved	Name	Änderung / modification	Datum / date

This electronic component has been designed and developed for usage in general electronic equipment. Before incorporating this component into any equipment where higher safety and reliability is especially required or if there is the possibility of direct damage or injury to human body, for example in the range of aerospace, aviation, nuclear control, submarine, transportation, (automotive control, train control, ship control), transportation signal, disaster prevention, medical, public information network etc. Würth Elektronik eiSos GmbH must be informed before the design-in stage. In addition, sufficient reliability evaluation checks for safety must be performed on every electronic component which is used in electrical circuits that require high safety and reliability functions or performance.

Würth Elektronik eiSos GmbH & Co.KG

D-74638 Waldenburg · Max-Eyth-Straße 1 - 3 · Germany · Telefon (+49) (0) 7942 - 945 - 0 · Telefax (+49) (0) 7942 - 945 - 400
http://www.we-online.com

Данный компонент на территории Российской Федерации

Вы можете приобрести в компании MosChip.

Для оперативного оформления запроса Вам необходимо перейти по данной ссылке:

<http://moschip.ru/get-element>

Вы можете разместить у нас заказ для любого Вашего проекта, будь то серийное производство или разработка единичного прибора.

В нашем ассортименте представлены ведущие мировые производители активных и пассивных электронных компонентов.

Нашей специализацией является поставка электронной компонентной базы двойного назначения, продукции таких производителей как XILINX, Intel (ex.ALTERA), Vicor, Microchip, Texas Instruments, Analog Devices, Mini-Circuits, Amphenol, Glenair.

Сотрудничество с глобальными дистрибьюторами электронных компонентов, предоставляет возможность заказывать и получать с международных складов практически любой перечень компонентов в оптимальные для Вас сроки.

На всех этапах разработки и производства наши партнеры могут получить квалифицированную поддержку опытных инженеров.

Система менеджмента качества компании отвечает требованиям в соответствии с ГОСТ Р ИСО 9001, ГОСТ РВ 0015-002 и ЭС РД 009

Офис по работе с юридическими лицами:

105318, г.Москва, ул.Щербаковская д.3, офис 1107, 1118, ДЦ «Щербаковский»

Телефон: +7 495 668-12-70 (многоканальный)

Факс: +7 495 668-12-70 (доб.304)

E-mail: info@moschip.ru

Skype отдела продаж:

moschip.ru

moschip.ru_4

moschip.ru_6

moschip.ru_9