

Specification

Quad Small Form-factor Pluggable Plus

QSFP+ Product



TQS-Q1LH8-X11xx

Distance

Part Number	Description
TQS-Q1LH8-X1101	40Gbps QSFP+ Active Optical Cable 1m
TQS-Q1LH8-X1103	40Gbps QSFP+ Active Optical Cable 3m
TQS-Q1LH8-X1105	40Gbps QSFP+ Active Optical Cable 5m
TQS-Q1LH8-X1107	40Gbps QSFP+ Active Optical Cable 7m
TQS-Q1LH8-X1110	40Gbps QSFP+ Active Optical Cable 10m
TQS-Q1LH8-X1120	40Gbps QSFP+ Active Optical Cable 20m

Model Name	Voltage	Category	Device type	Interface	LOS	Temperature
TQS-Q1LH8-X11xx	3.3V	With DDMI	VCSEL/PIN	CML/CML	LVTTTL	0°C ~ +70°C

Description

Formerica OptoElectronics Inc. Quad Small Form-factor Pluggable (QSFP) product is a new high speed pluggable I/O interface products. This interconnecting system offers 4 channels and maximum bandwidth of 40Gbps which are based on the proprietary technique Silicon Optical Bench (SiOB). This module provides high performance and excellent efficiency in the optical communication.

Features

- Compliant with 40G Ethernet IEEE 802.3ae 40GBASE-SR4 standards
- QSFP footprint (Quad small form-factor, pluggable)
- Supports 40 Gbps data rate links of up to 100 m
- Compliant with QDR/DDR Infiniband data rates
- Hot pluggable electrical interface
- RoHS Compliant

Applications

- 40GBASE-SR4 Ethernet links
- Infiniband QDR and DDR interconnects
- Client-side 40G Telecom connections

Absolute Maximum Rating

Not necessarily applied together. Exceeding these values may cause permanent damage. Functional operation under these conditions is not implied.

Parameter	Symbol	Min	Typical	Max	Unit	Note
Storage Temperature	Ts	0		70	°C	1
Relative Humidity	RH	5		85	%	2
Data Input Voltage- Single Ended		-0.5		Vcc+0.5		
Center Wavelength	λ	840		860	nm	

Notes:

1. Limited by the fiber cable jacket, not the active ends.
2. Non-condensing.

Recommended Operatin Conditions

Parameter	Symbol	Min	Typical	Max	Unit	Note
Case Temperature	Top	0	40	70	°C	
3.3 V Power Supply Voltage	Vcc	3.135	3.3	3.465	V	
Signal Rate per Channel		2.5		10.3125	GB/s	1
Control* Input Voltage High	Vih	2		Vcc+0.3	V	
Control* Input Voltage Low	Vil	-0.3		0.8	V	
Two Wire Serial (TWS) Interface Clock Rate			100		kHz	
Power Supply Noise				50	mV	2
Receiver Differential Data Output Load			100		Ohms	
Standard Cable Lengths		3		100	m	
Bit Error Ratio			10 ⁻¹²			3

Notes:

1. Lane speed up to 12.5-Gbps is available upon customer requests.
2. Power supply noise is defined as peak-to-peak noise amplitude over 1K to 15 MHz frequency range at host supply side by the recommended power supply filter for module. See Section 10 for the recommended power supply filter.
3. Bit-Error-Rate (BER) is tested with PRBS 2³¹-1 pattern.

Electrical Characteristics

Parameter	Symbol	Min	Typical	Max	Unit	Note
Transceiver						
Power Consumption				1.5	W	
Supply Current				420	mA	
Initialization Time	tpwr init			2000	ms	1
Receiver						
Data Output Differential Peak-to-Peak Voltage Swing	ΔVDO pp	200		900	mVpp	
Output Total Jitter				62	ps	
BER				10^{-12}		PRBS3 1

Notes:

1. "Initialization Time" is the time from when the supply voltages reach and remain above the minimum "Recommended Operating Conditions" to the time when the module enables TWS access. The module at that point is fully functional.

Recommended Host Board POWER Supply Circuit

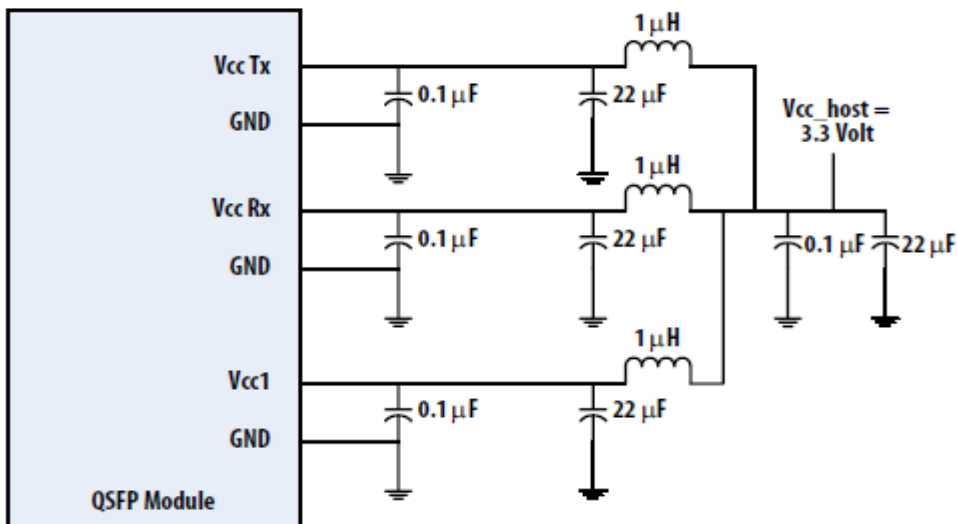

QSFP+ Module Pad Assignments and Descriptions

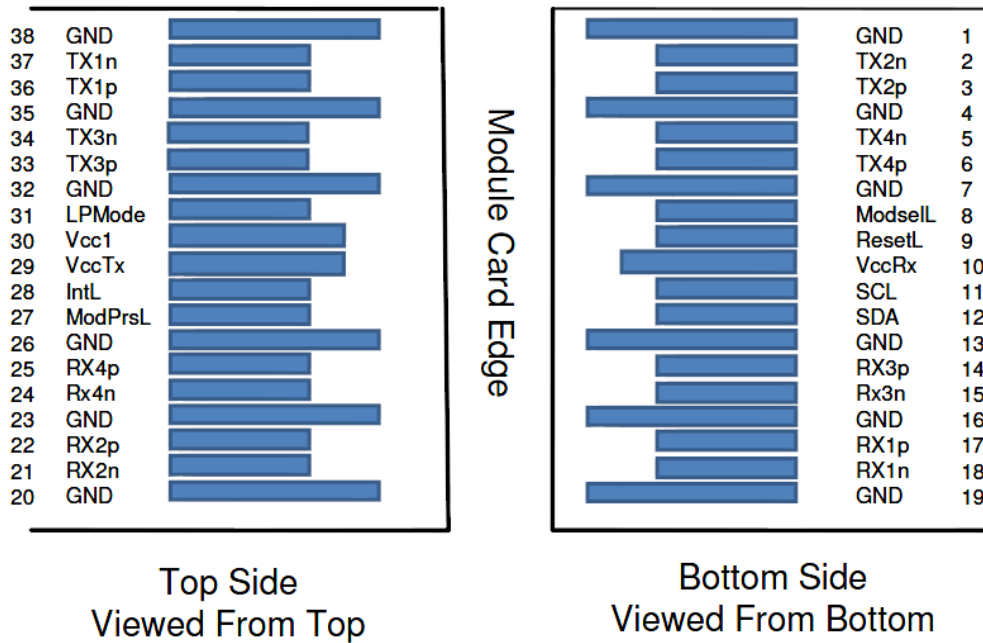

Pin	Logic	Symbol	Description	Plug Sequence	Notes
1		GND	Ground	1	1
2	CML-I	Tx2n	Transmitter Inverted Data Input	3	
3	CML-I	Tx2p	Transmitter Non-Inverted Data Input	3	
4		GND	Ground	1	1
5	CML-I	Tx4n	Transmitter Inverted Data Input	3	
6	CML-I	Tx4p	Transmitter Non-Inverted Data Input	3	
7		GND	Ground	1	1
8	LVTTL-I	ModSelL	Module Select	3	
9	LVTTL-I	ResetL	Module Reset	3	
10		Vcc Rx	+3.3V Power Supply Receiver	2	2
11	LVC MOS-I/O	SCL	2-wire serial interface clock	3	
12	LVC MOS-I/O	SDA	2-wire serial interface data	3	
13		GND	Ground	1	2
14	CML-O	Rx3p	Receiver Non-Inverted Data Output	3	
15	CML-O	Rx3n	Receiver Inverted Data Output	3	
16		GND	Ground	1	1

17	CML-O	Rx1p	Receiver Non-Inverted Data Output	3	
18	CML-O	Rx1n	Receiver Inverted Data Output	3	
19		GND	Ground	1	1
20		GND	Ground	1	1
21	CML-O	Rx2n	Receiver Inverted Data Output	3	
22	CML-O	Rx2p	Receiver Non-Inverted Data Output	3	
23		GND	Ground	1	1
24	CML-O	Rx4n	Receiver Inverted Data Output	3	
25	CML-O	Rx4p	Receiver Non-Inverted Data Output	3	
26		GND	Ground	1	1
27	LVTTL-O	ModPrsL	Module Present	3	
28	LVTTL-O	IntL	Interrupt	3	
29		Vcc Tx	+3.3V Power supply transmitter	2	2
30		Vcc1	+3.3V Power supply	2	2
31	LVTTL-I	LPMode	Low Power Mode	3	
32		GND	Ground	1	1
33	CML-I	Tx3p	Transmitter Non-Inverted Data Input	3	
34	CML-I	Tx3n	Transmitter Inverted Data Input	3	
35		GND	Ground	1	1
36	CML-I	Tx1p	Transmitter Non-Inverted Data Input	3	
37	CML-I	Tx1n	Transmitter Inverted Data Input	3	
38		GND	Ground	1	1

Note :

1. **GND is the symbol for signal and supply (power) common for the QSFP module. All are common within the QSFP+ module and all module voltages are referenced to this potential unless otherwise noted. Connect these directly to the host board signal-common ground plane.**
2. **Vcc Rx, Vcc1 and Vcc Tx are the receiver and transmitter power supplies and shall be applied concurrently. Requirements defined for the host side of the Host Edge Card Connector are listed in Table. Recommended host board power supply filtering is shown in Host board power supply circuit. Vcc Rx Vcc1 and Vcc Tx may be internally connected within the QSFP+ module in any combination. The connector pins are each rated for a maximum current of 500 mA.**

Memory Map

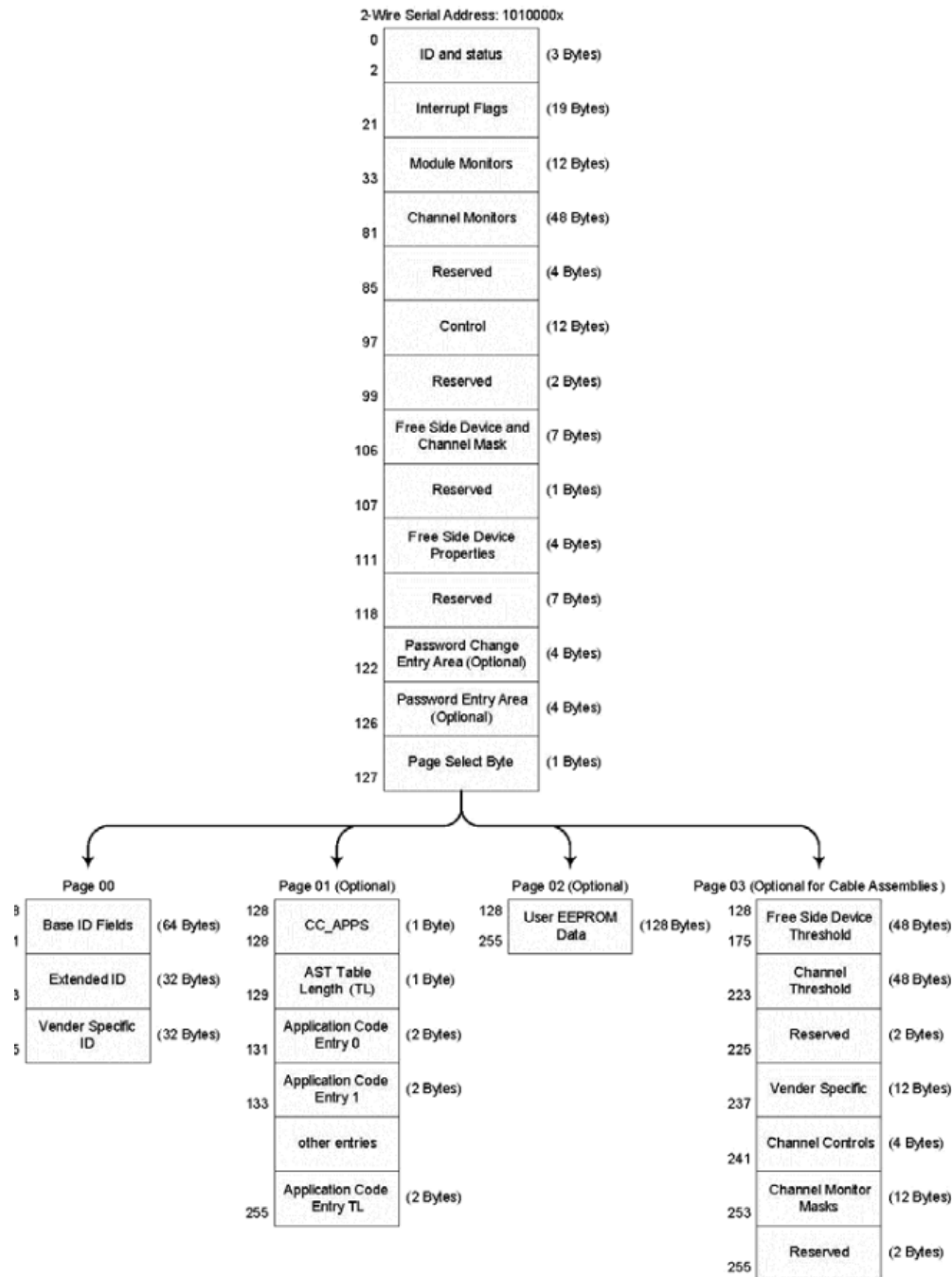

Module Outline

Unit: mm

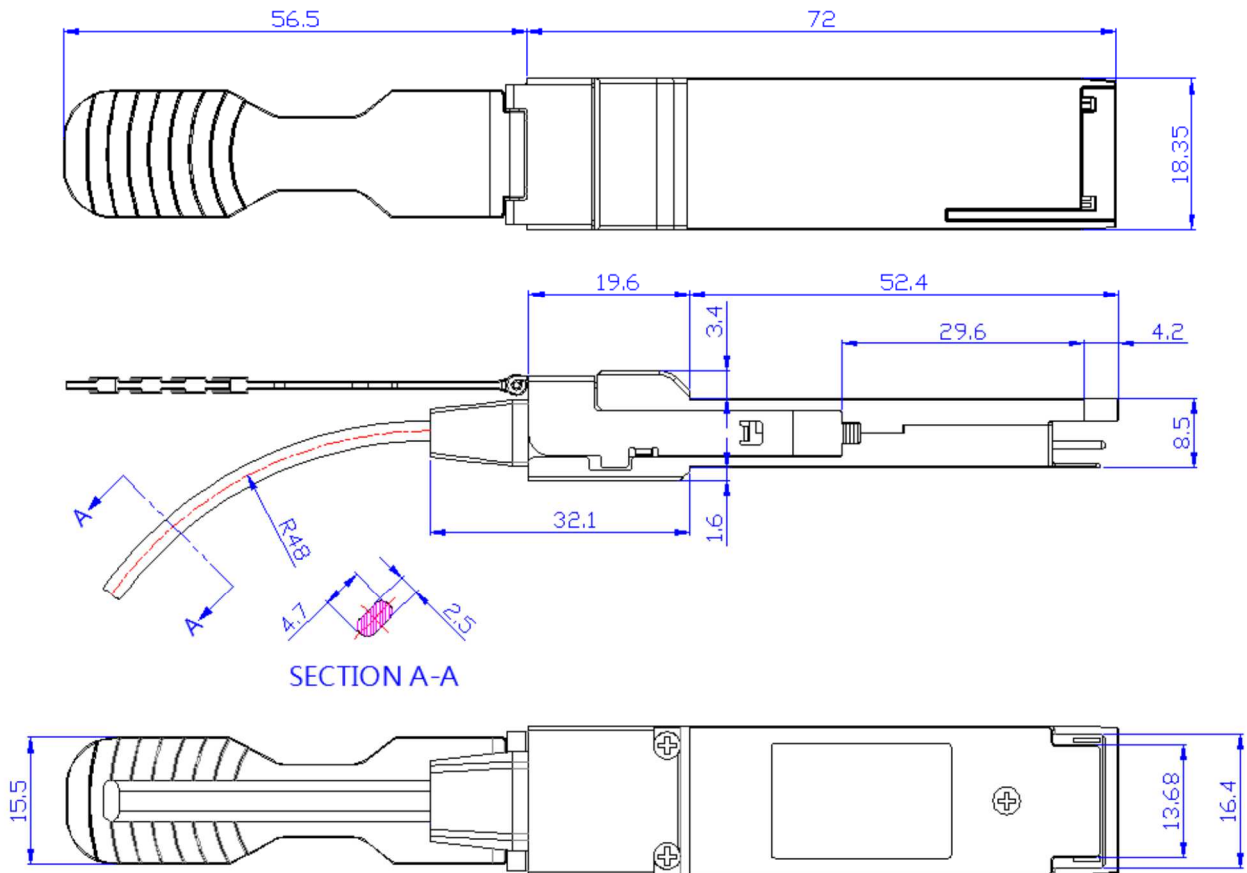

ESD

Normal ESD precautions are required during the handling of this module. This transceiver is shipped in ESD protective packaging. It should be removed from the packaging and handled only in an ESD protected environment.



Contact Information

Formerica OptoElectronics Inc.

5F-11, No.38, Taiyuan St., Zhubei City,
Hsinchu County 30265, Taiwan

Tel: +886-3-5600286

Fax: +886-3-5600239

San Diego, CA

Tel: 1-949-466-8069

inquiry@formericaoe.com

www.formericaoe.com

Данный компонент на территории Российской Федерации

Вы можете приобрести в компании MosChip.

Для оперативного оформления запроса Вам необходимо перейти по данной ссылке:

<http://moschip.ru/get-element>

Вы можете разместить у нас заказ для любого Вашего проекта, будь то серийное производство или разработка единичного прибора.

В нашем ассортименте представлены ведущие мировые производители активных и пассивных электронных компонентов.

Нашей специализацией является поставка электронной компонентной базы двойного назначения, продукции таких производителей как XILINX, Intel (ex.ALTERA), Vicor, Microchip, Texas Instruments, Analog Devices, Mini-Circuits, Amphenol, Glenair.

Сотрудничество с глобальными дистрибьюторами электронных компонентов, предоставляет возможность заказывать и получать с международных складов практически любой перечень компонентов в оптимальные для Вас сроки.

На всех этапах разработки и производства наши партнеры могут получить квалифицированную поддержку опытных инженеров.

Система менеджмента качества компании отвечает требованиям в соответствии с ГОСТ Р ИСО 9001, ГОСТ РВ 0015-002 и ЭС РД 009

Офис по работе с юридическими лицами:

105318, г.Москва, ул.Щербаковская д.3, офис 1107, 1118, ДЦ «Щербаковский»

Телефон: +7 495 668-12-70 (многоканальный)

Факс: +7 495 668-12-70 (доб.304)

E-mail: info@moschip.ru

Skype отдела продаж:

moschip.ru

moschip.ru_4

moschip.ru_6

moschip.ru_9