

# EPSON®



## S1D13705 Embedded Memory LCD Controller

# S1D13705 TECHNICAL MANUAL

Document No. X27A-Q-001-04

Copyright © 2001 Epson Research and Development, Inc. All Rights Reserved.

Information in this document is subject to change without notice. You may download and use this document, but only for your own use in evaluating Seiko Epson/EPSON products. You may not modify the document. Epson Research and Development, Inc. disclaims any representation that the contents of this document are accurate or current. The Programs/Technologies described in this document may contain material protected under U.S. and/or International Patent laws.

EPSON is a registered trademark of Seiko Epson Corporation. All other Trademarks are the property of their respective owners

---

**THIS PAGE LEFT BLANK**

# Customer Support Information

## Comprehensive Support Tools

Seiko Epson Corp. provides to the system designer and computer OEM manufacturer a complete set of resources and tools for the development of graphics systems.

## Evaluation / Demonstration Board

- Assembled and fully tested graphics evaluation board with installation guide and schematics.
- To borrow an evaluation board, please contact your local Seiko Epson Corp. sales representative.

## Chip Documentation

- Technical manual includes Data Sheet, Application Notes, and Programmer's Reference.

## Software

- OEM Utilities.
- User Utilities.
- Evaluation Software.
- To obtain these programs, contact Application Engineering Support.

## Application Engineering Support

Engineering and Sales Support is provided by:

### Japan

Seiko Epson Corporation  
Electronic Devices Marketing Division  
421-8, Hino, Hino-shi  
Tokyo 191-8501, Japan  
Tel: 042-587-5812  
Fax: 042-587-5564  
<http://www.epson.co.jp>

### North America

Epson Electronics America, Inc.  
150 River Oaks Parkway  
San Jose, CA 95134, USA  
Tel: (408) 922-0200  
Fax: (408) 922-0238  
<http://www.eea.epson.com>

### Taiwan

Epson Taiwan Technology  
& Trading Ltd.  
10F, No. 287  
Nanking East Road  
Sec. 3, Taipei, Taiwan  
Tel: 02-2717-7360  
Fax: 02-2712-9164

### Hong Kong

Epson Hong Kong Ltd.  
20/F., Harbour Centre  
25 Harbour Road  
Wanchai, Hong Kong  
Tel: 2585-4600  
Fax: 2827-4346

### Europe

Epson Europe Electronics GmbH  
Riesstrasse 15  
80992 Munich, Germany  
Tel: 089-14005-0  
Fax: 089-14005-110

### Singapore

Epson Singapore Pte., Ltd.  
No. 1  
Temasek Avenue #36-00  
Millenia Tower  
Singapore, 039192  
Tel: 337-7911  
Fax: 334-2716

**THIS PAGE LEFT BLANK**

## S1D13705 Embedded Memory LCD Controller

The S1D13705 is a color/monochrome LCD graphics controller with an embedded 80K Byte SRAM display buffer. The high integration of the S1D13705 provides a low cost, low power, single chip solution to meet the requirements of embedded markets such as Office Automation equipment, Mobile Communications devices, and Palm-size PCs where board size and battery life are major concerns.

Products requiring a "Portrait" display can take advantage of the Hardware Portrait Mode feature of the S1D13705. Virtual and Split Screen are just some of the display modes supported. While focusing on devices targeted by the Microsoft Windows CE Operating System, the S1D13705's impartiality to CPU type or operating system makes it an ideal display solution for a wide variety of applications.

### ■ FEATURES

- Embedded 80K byte SRAM display buffer.
- Direct support for the following CPU's:
  - Hitachi SH-3.
  - Hitachi SH-4.
  - Motorola M68xxx.
- MPU bus interface with programmable READY.
- Resolutions up to:
  - 640x480 at a color depth of 2 bpp.
  - 640x240 at a color depth of 4 bpp.
  - 320x240 at a color depth of 8 bpp.
- Up to 256 simultaneous colors from a possible 4096 colors on passive LCD panels and active matrix TFT/D-TFD LCD panels.
- Register level support for EL panels.
- Hardware Portrait Mode
- Split Screen Display
- Virtual Display Support
- LCD power-down sequencing.

### ■ SYSTEM BLOCK DIAGRAM

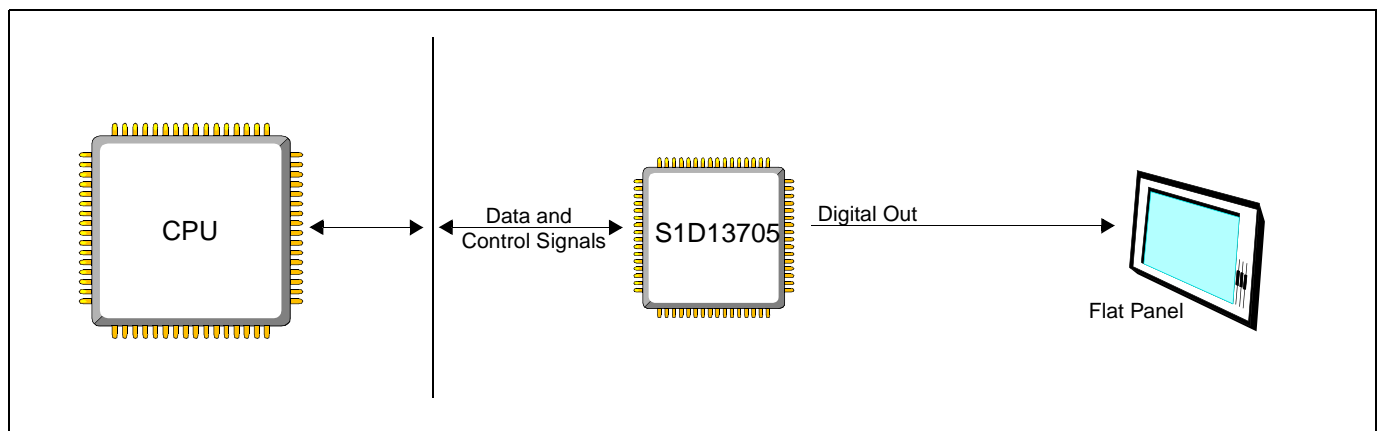

## S1D13705

### DESCRIPTION

#### Memory Interface

- Embedded 80K byte SRAM display buffer.

#### CPU Interface

- Direct support for:
  - Hitachi SH-3.
  - Hitachi SH-4.
  - Motorola M68xxx.
- MPU bus interface with programmable READY.
- CPU write buffer.

#### Display Support

- 4/8-bit monochrome LCD interface.
- 4/8-bit color LCD interface.
- Single-panel, single-drive passive displays.
- Dual-panel, dual-drive passive displays.
- Active matrix TFT / D-TFD interface.
- Example resolutions:
  - 640x480 at a color depth of 2 bpp.
  - 640x240 at a color depth of 4 bpp.
  - 320x240 at a color depth of 8 bpp.

#### Clock Source

- Single clock input for both pixel and memory clocks.
- The S1D13705 clock source can be internally divided down for a higher frequency clock input.
- Dynamic switching of memory clocks in portrait mode.

#### Display Modes

- 1/2/4/8 bit-per-pixel (bpp) support on LCD.
- Up to 16 shades of gray using FRM on monochrome passive LCD panels.
- Up to 256 simultaneous colors from a possible 4096 colors on passive STN and active matrix TFT/D-TFD LCD panels.
- Split Screen Display: allows two different images to be simultaneously viewed on the same display.
- Virtual Display Support: displays images larger than the display size through the use of panning.
- Double Buffering/multi-pages: provides smooth animation and instantaneous screen update.
- Hardware Portrait Mode: direct hardware 90° rotation of display image for portrait mode display.

#### Power Down Modes

- Software Suspend mode.
- LCD power-down sequencing.

#### Operating Voltage

- CORE<sub>VDD</sub> 2.7 to 3.6 volts; IO<sub>VDD</sub> 2.7 to 5.5 volts.

#### Package

- 80-pin QFP14.

### CONTACT YOUR SALES REPRESENTATIVE FOR THESE COMPREHENSIVE DESIGN TOOLS:

- S1D13705 Technical Manual
- S5U13705 Evaluation Boards
- Windows<sup>®</sup> CE Display Driver
- CPU Independent Software Utilities

#### Japan

Seiko Epson Corporation  
Electronic Devices Marketing Division  
421-8, Hino, Hino-shi  
Tokyo 191-8501, Japan  
Tel: 042-587-5812  
Fax: 042-587-5564  
<http://www.epson.co.jp>

#### North America

Epson Electronics America, Inc.  
150 River Oaks Parkway  
San Jose, CA 95134, USA  
Tel: (408) 922-0200  
Fax: (408) 922-0238  
<http://www.eea.epson.com>

#### Taiwan

Epson Taiwan Technology  
& Trading Ltd.  
10F, No. 287  
Nanking East Road  
Sec. 3, Taipei, Taiwan  
Tel: 02-2717-7360  
Fax: 02-2712-9164

#### Hong Kong

Epson Hong Kong Ltd.  
20/F., Harbour Centre  
25 Harbour Road  
Wanchai, Hong Kong  
Tel: 2585-4600  
Fax: 2827-4346

#### Europe

Epson Europe Electronics GmbH  
Riesstrasse 15  
80992 Munich, Germany  
Tel: 089-14005-0  
Fax: 089-14005-110

#### Singapore

Epson Singapore Pte., Ltd.  
No. 1  
Temasek Avenue #36-00  
Millenia Tower  
Singapore, 039192  
Tel: 337-7911  
Fax: 334-2716

### FOR SYSTEM INTEGRATION SERVICES FOR WINDOWS<sup>®</sup> CE CONTACT:

Epson Research & Development, Inc.  
Suite #320 - 11120 Horseshoe Way  
Richmond, B.C., Canada V7A 5H7  
Tel: (604) 275-5151  
Fax: (604) 275-2167  
Email: [wince@erd.epson.com](mailto:wince@erd.epson.com)  
<http://www.erd.epson.com>



Copyright © 2001 Epson Research and Development, Inc. All rights reserved. Information in this document is subject to change without notice. You may download and use this document, but only for your own use in evaluating Seiko Epson/EPSON products. You may not modify the document. Epson Research and Development, Inc. disclaims any representation that the contents of this document are accurate or current. The Programs/Technologies described in this document may contain material protected under U.S. and/or International Patent laws. EPSON is a registered trademark of Seiko Epson Corporation. Microsoft, Windows, and the Windows CE Logo are registered trademarks of Microsoft Corporation.

# EPSON®



## S1D13705 Embedded Memory LCD Controller

# Hardware Functional Specification

**Document Number: X27A-A-001-10**

Copyright © 1999, 2002 Epson Research and Development, Inc. All Rights Reserved.

Information in this document is subject to change without notice. You may download and use this document, but only for your own use in evaluating Seiko Epson/EPSON products. You may not modify the document. Epson Research and Development, Inc. disclaims any representation that the contents of this document are accurate or current. The Programs/Technologies described in this document may contain material protected under U.S. and/or International Patent laws.

EPSON is a registered trademark of Seiko Epson Corporation. All other Trademarks are the property of their respective owners

---

**THIS PAGE LEFT BLANK**



# Table of Contents

<b>1</b>	<b>Introduction</b>	<b>9</b>
1.1	Scope	9
1.2	Overview Description	9
<b>2</b>	<b>Features</b>	<b>10</b>
2.1	Integrated Frame Buffer	10
2.2	CPU Interface	10
2.3	Display Support	10
2.4	Display Modes	11
2.5	Clock Source	11
2.6	Miscellaneous	11
2.7	Package	11
<b>3</b>	<b>Typical System Implementation Diagrams</b>	<b>12</b>
<b>4</b>	<b>Functional Block Diagram</b>	<b>15</b>
4.1	Functional Block Descriptions	15
4.1.1	Host Interface	15
4.1.2	Memory Controller	15
4.1.3	Sequence Controller	15
4.1.4	Look-Up Table	16
4.1.5	LCD Interface	16
4.1.6	Power Save	16
<b>5</b>	<b>Pins</b>	<b>17</b>
5.1	Pinout Diagram	17
5.2	Pin Description	18
5.2.1	Host Interface	18
5.2.2	LCD Interface	20
5.2.3	Clock Input	21
5.2.4	Miscellaneous	21
5.2.5	Power Supply	21
5.3	Summary of Configuration Options	22
5.4	Host Bus Interface Pin Mapping	22
5.5	LCD Interface Pin Mapping	23
<b>6</b>	<b>D.C. Characteristics</b>	<b>24</b>
<b>7</b>	<b>A.C. Characteristics</b>	<b>26</b>
7.1	Bus Interface Timing	26
7.1.1	SH-4 Interface Timing	26
7.1.2	SH-3 Interface Timing	28
7.1.3	Motorola MC68K #1 Interface Timing	30
7.1.4	Motorola MC68K #2 Interface Timing	31

7.1.5	Generic #1 Interface Timing . . . . .	32
7.1.6	Generic #2 Interface Timing . . . . .	33
7.2	Clock Input Requirements . . . . .	34
7.3	Display Interface . . . . .	36
7.3.1	Power On/Reset Timing . . . . .	36
7.3.2	Power Down/Up Timing . . . . .	37
7.3.3	Single Monochrome 4-Bit Panel Timing . . . . .	38
7.3.4	Single Monochrome 8-Bit Panel Timing . . . . .	40
7.3.5	Single Color 4-Bit Panel Timing . . . . .	42
7.3.6	Single Color 8-Bit Panel Timing (Format 1) . . . . .	44
7.3.7	Single Color 8-Bit Panel Timing (Format 2) . . . . .	46
7.3.8	Dual Monochrome 8-Bit Panel Timing . . . . .	48
7.3.9	Dual Color 8-Bit Panel Timing . . . . .	50
7.3.10	9/12-Bit TFT/D-TFD Panel Timing . . . . .	52
<b>8</b>	<b>Registers . . . . .</b>	<b>.55</b>
8.1	Register Mapping . . . . .	.55
8.2	Register Descriptions . . . . .	.55
<b>9</b>	<b>Frame Rate Calculation . . . . .</b>	<b>.69</b>
<b>10</b>	<b>Display Data Formats . . . . .</b>	<b>.70</b>
<b>11</b>	<b>Look-Up Table Architecture . . . . .</b>	<b>.71</b>
11.1	Monochrome Modes . . . . .	.71
11.2	Color Modes . . . . .	.73
<b>12</b>	<b>SwivelView™ . . . . .</b>	<b>.77</b>
12.1	Default SwivelView Mode . . . . .	.77
12.1.1	How to Set Up Default SwivelView Mode . . . . .	.78
12.2	Alternate SwivelView Mode . . . . .	.79
12.2.1	How to Set Up Alternate SwivelView Mode . . . . .	.80
12.3	Comparison Between Default and Alternate SwivelView Modes . . . . .	.81
12.4	SwivelView Mode Limitations . . . . .	.81
<b>13</b>	<b>Power Save Modes . . . . .</b>	<b>.82</b>
13.1	Software Power Save Mode . . . . .	.82
13.2	Hardware Power Save Mode . . . . .	.82
13.3	Power Save Mode Function Summary . . . . .	.83
13.4	Panel Power Up/Down Sequence . . . . .	.83
13.5	Turning Off BCLK Between Accesses . . . . .	.84
13.6	Clock Requirements . . . . .	.85
<b>14</b>	<b>Mechanical Data . . . . .</b>	<b>.86</b>
<b>15</b>	<b>Sales and Technical Support . . . . .</b>	<b>.87</b>

## List of Tables

Table 5-1: Summary of Power On/Reset Options . . . . .	22
Table 5-2: Host Bus Interface Pin Mapping . . . . .	22
Table 5-3: LCD Interface Pin Mapping . . . . .	23
Table 6-1: Absolute Maximum Ratings . . . . .	24
Table 6-2: Recommended Operating Conditions for Core VDD = 3.3V ± 10% . . . . .	24
Table 6-3: Input Specifications . . . . .	24
Table 6-4: Output Specifications. . . . .	25
Table 7-1: SH-4 Timing . . . . .	27
Table 7-2: SH-3 Bus Timing . . . . .	29
Table 7-3: MC68K #1 Bus Timing (MC68000) . . . . .	30
Table 7-4: MC68K #2 Timing (MC68030) . . . . .	31
Table 7-5: Generic #1 Timing . . . . .	32
Table 7-6: Generic #2 Timing . . . . .	33
Table 7-7: Clock Input Requirements for CLKI . . . . .	34
Table 7-8: Clock Input Requirements for BCLK . . . . .	35
Table 7-9: LCD Panel Power On/Reset Timing . . . . .	36
Table 7-10: Power Down/Up Timing . . . . .	37
Table 7-11: Single Monochrome 4-Bit Panel A.C. Timing . . . . .	39
Table 7-12: Single Monochrome 8-Bit Panel A.C. Timing . . . . .	41
Table 7-13: Single Color 4-Bit Panel A.C. Timing . . . . .	43
Table 7-14: Single Color 8-Bit Panel A.C. Timing (Format 1) . . . . .	45
Table 7-15: Single Color 8-Bit Panel A.C. Timing (Format 2) . . . . .	47
Table 7-16: Dual Monochrome 8-Bit Panel A.C. Timing . . . . .	49
Table 7-17: Dual Color 8-Bit Panel A.C. Timing . . . . .	51
Table 7-18: TFT/D-TFD A.C. Timing . . . . .	54
Table 8-1: Panel Data Format . . . . .	56
Table 8-2: Gray Scale/Color Mode Selection . . . . .	57
Table 8-3: High Performance Selection . . . . .	57
Table 8-4: Inverse Video Mode Select Options . . . . .	58
Table 8-5: Hardware Power Save/GPIO0 Operation . . . . .	59
Table 8-6: Software Power Save Mode Selection . . . . .	59
Table 8-7: Selection of SwivelView Mode . . . . .	67
Table 8-8: Selection of PCLK and MCLK in SwivelView Mode . . . . .	68
Table 12-1: Default and Alternate SwivelView Mode Comparison . . . . .	81
Table 13-1: Power Save Mode Selection . . . . .	82
Table 13-2: Software Power Save Mode Summary . . . . .	82
Table 13-3: Hardware Power Save Mode Summary . . . . .	82
Table 13-4: Power Save Mode Function Summary . . . . .	83
Table 13-5: S1D13705 Internal Clock Requirements . . . . .	85

**THIS PAGE LEFT BLANK**

## List of Figures

Figure 3-1: Typical System Diagram (SH-4 Bus) . . . . .	12
Figure 3-2: Typical System Diagram (SH-3 Bus) . . . . .	12
Figure 3-3: Typical System Diagram (M68K #1 Bus) . . . . .	13
Figure 3-4: Typical System Diagram (M68K #2 Bus) . . . . .	13
Figure 3-5: Typical System Diagram (Generic #1 Bus) . . . . .	14
Figure 3-6: Typical System Diagram (Generic #2 Bus - e.g. ISA Bus) . . . . .	14
Figure 4-1: System Block Diagram Showing Data Paths . . . . .	15
Figure 5-1: Pinout Diagram . . . . .	17
Figure 7-1: SH-4 Timing . . . . .	26
Figure 7-2: SH-3 Bus Timing . . . . .	28
Figure 7-3: MC68K #1 Bus Timing (MC68000) . . . . .	30
Figure 7-4: MC68K #2 Timing (MC68030) . . . . .	31
Figure 7-5: Generic #1 Timing . . . . .	32
Figure 7-6: Generic #2 Timing . . . . .	33
Figure 7-7: Clock Input Requirements for CLKI . . . . .	34
Figure 7-8: Clock Input Requirements for BCLK . . . . .	35
Figure 7-9: LCD Panel Power On/Reset Timing . . . . .	36
Figure 7-10: Power Down/Up Timing . . . . .	37
Figure 7-11: Single Monochrome 4-Bit Panel Timing . . . . .	38
Figure 7-12: Single Monochrome 4-Bit Panel A.C. Timing . . . . .	39
Figure 7-13: Single Monochrome 8-Bit Panel Timing . . . . .	40
Figure 7-14: Single Monochrome 8-Bit Panel A.C. Timing . . . . .	41
Figure 7-15: Single Color 4-Bit Panel Timing . . . . .	42
Figure 7-16: Single Color 4-Bit Panel A.C. Timing . . . . .	43
Figure 7-17: Single Color 8-Bit Panel Timing (Format 1) . . . . .	44
Figure 7-18: Single Color 8-Bit Panel A.C. Timing (Format 1) . . . . .	45
Figure 7-19: Single Color 8-Bit Panel Timing (Format 2) . . . . .	46
Figure 7-20: Single Color 8-Bit Panel A.C. Timing (Format 2) . . . . .	47
Figure 7-21: Dual Monochrome 8-Bit Panel Timing . . . . .	48
Figure 7-22: Dual Monochrome 8-Bit Panel A.C. Timing . . . . .	49
Figure 7-23: Dual Color 8-Bit Panel Timing . . . . .	50
Figure 7-24: Dual Color 8-Bit Panel A.C. Timing . . . . .	51
Figure 7-25: 12-Bit TFT/D-TFD Panel Timing . . . . .	52
Figure 7-26: TFT/D-TFD A.C. Timing . . . . .	53
Figure 8-1: Screen-Register Relationship, Split Screen. . . . .	65
Figure 10-1: 1/2/4/8 Bit-Per-Pixel Display Data Memory Organization. . . . .	70
Figure 11-1: 1 Bit-per-pixel Monochrome Mode Data Output Path . . . . .	71

Figure 11-2: 2 Bit-per-pixel Monochrome Mode Data Output Path . . . . .71

Figure 11-3: 4 Bit-per-pixel Monochrome Mode Data Output Path . . . . .72

Figure 11-4: 1 Bit-per-pixel Color Mode Data Output Path . . . . .73

Figure 11-5: 2 Bit-per-pixel Color Mode Data Output Path . . . . .74

Figure 11-6: 4 Bit-per-pixel Color Mode Data Output Path . . . . .75

Figure 11-7: 8 Bit-per-pixel Color Mode Data Output Path . . . . .76

Figure 12-1: Relationship Between The Screen Image and the Image Refreshed by  
S1D13705 in Default Mode. . . . .77

Figure 12-2: Relationship Between The Screen Image and the Image Refreshed by  
S1D13705 in Alternate Mode. . . . .79

Figure 13-1: Panel On/Off Sequence . . . . .84

Figure 14-1: Mechanical Drawing QFP14 . . . . .86

---

# 1 Introduction

## 1.1 Scope

This is the Hardware Functional Specification for the S1D13705 Embedded Memory LCD Controller Chip. Included in this document are timing diagrams, AC and DC characteristics, register descriptions, and power management descriptions. This document is intended for two audiences: Video Subsystem Designers and Software Developers.

This document is updated as appropriate. Please check for the latest revision of this document before beginning any development. The latest revision can be downloaded at [www.erd.epson.com](http://www.erd.epson.com).

We appreciate your comments on our documentation. Please contact us via email at [documentation@erd.epson.com](mailto:documentation@erd.epson.com).

## 1.2 Overview Description

The S1D13705 is a color / monochrome LCD graphics controller with an embedded 80K byte SRAM display buffer. The high integration of the S1D13705 provides a low cost, low power, single chip solution to meet the requirements of embedded markets such as Office Automation equipment, Mobile Communications devices, and Hand-Held PCs where board size and battery life are major concerns.

Products requiring a "Portrait" display can take advantage of the SwivelView™ Mode feature of the S1D13705. Virtual and Split Screen are just some of the display modes supported. The above features, combined with the Operating System independence of the S1D13705, make it the ideal solution for a wide variety of applications.

## 2 Features

### 2.1 Integrated Frame Buffer

- Embedded 80K byte SRAM display buffer.

### 2.2 CPU Interface

- Direct support of the following interfaces:
  - Hitachi SH-3.
  - Hitachi SH-4.
  - Motorola M68K.
  - MPU bus interface using WAIT# signal.
- Direct memory mapping of internal registers.
- Single level CPU write buffer.
- Registers are mapped into upper 32 bytes of 128K byte address space.
- The complete 80K byte display buffer is directly and contiguously available through the 17-bit address bus.

### 2.3 Display Support

- 4/8-bit monochrome LCD interface.
- 4/8-bit color LCD interface.
- Single-panel, single-drive passive displays.
- Dual-panel, dual-drive passive displays.
- Active Matrix TFT / D-TFD interface
- Register level support for EL panels.
- Example resolutions:
  - 640x480 at a color depth of 2 bpp
  - 640x240 at a color depth of 4 bpp
  - 320x240 at a color depth of 8 bpp



## 2.4 Display Modes

- SwivelView™: direct 90° hardware rotation of display image for portrait mode display
- 1/2/4 bit-per-pixel (bpp), 2/4/16-level grayscale display.
- 1/2/4/8 bit-per-pixel, 2/4/16/256-level color display.
- Up to 16 shades of gray by FRM on monochrome passive LCD panels; a 256x4 Look-Up Table is used to map 1/2/4 bpp modes into these shades.
- 256 simultaneous of 4096 colors on color passive and active matrix LCD panels; three 256x4 Look-Up Tables are used to map 1/2/4/8 bpp modes into these colors.
- Split screen display for all landscape panel modes allows two different images to be simultaneously displayed.
- Virtual display support (displays images larger than the panel size through the use of panning).

## 2.5 Clock Source

- Maximum operating clock (CLK) frequency of 25MHz.
- Operating clock (CLK) is derived from CLKI input.  
CLK = CLKI  
or  
CLK = CLKI/2
- Pixel Clock (PCLK) and Memory Clock (MCLK) are derived from CLK.

## 2.6 Miscellaneous

- Hardware/Software Video Invert.
- Software Power Save mode.
- Hardware Power Save mode.
- LCD power-down sequencing.
- 5 General Purpose Input/Output pins are available.
  - GPIO0 is available if Hardware Power Save is not required.
  - GPIO[4:1] are available if upper LCD data pins (FPDAT[11:8]) are not required for TFT/D-TFD support or hardware inverse video.
- Core operates from 2.7 volts to 3.6 volts.
- IO Operates from the core voltage up to 5.5 volts.

## 2.7 Package

- 80 pin QFP14 package.

### 3 Typical System Implementation Diagrams

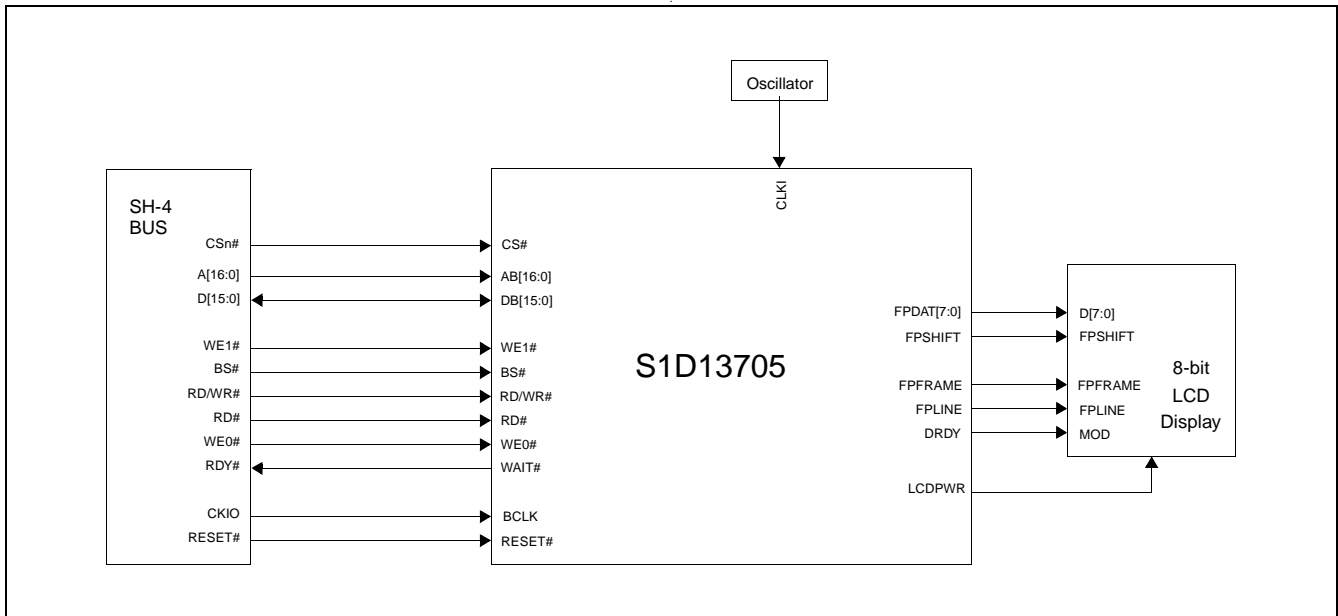

Figure 3-1: Typical System Diagram (SH-4 Bus)

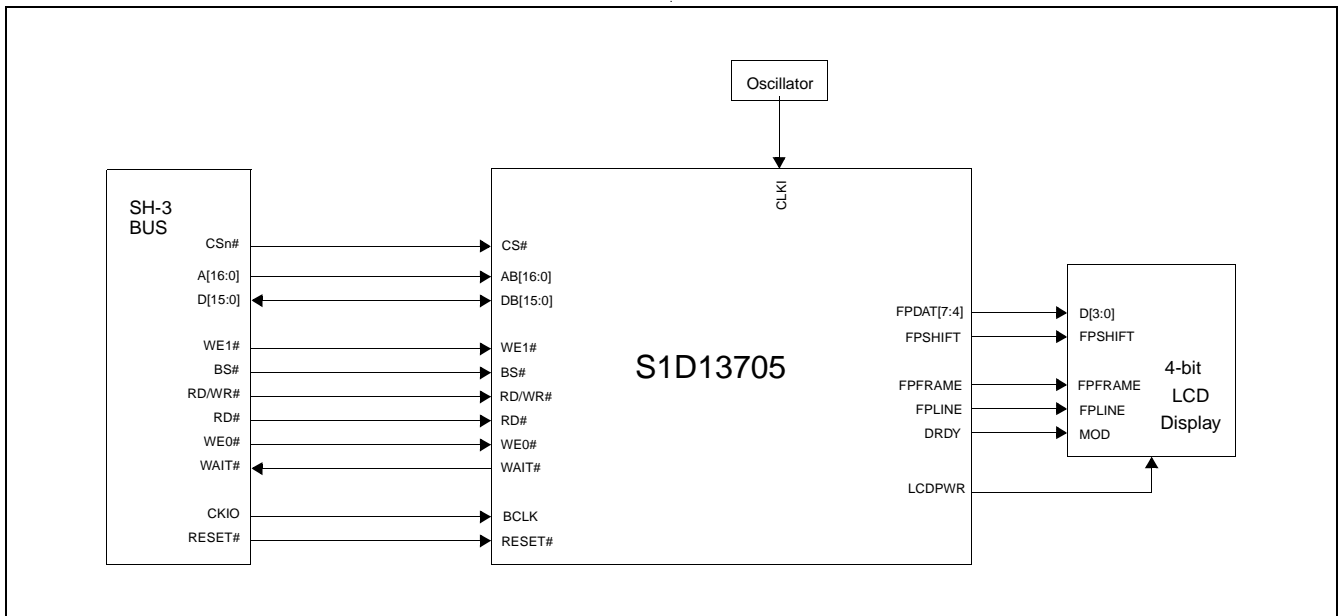

Figure 3-2: Typical System Diagram (SH-3 Bus)

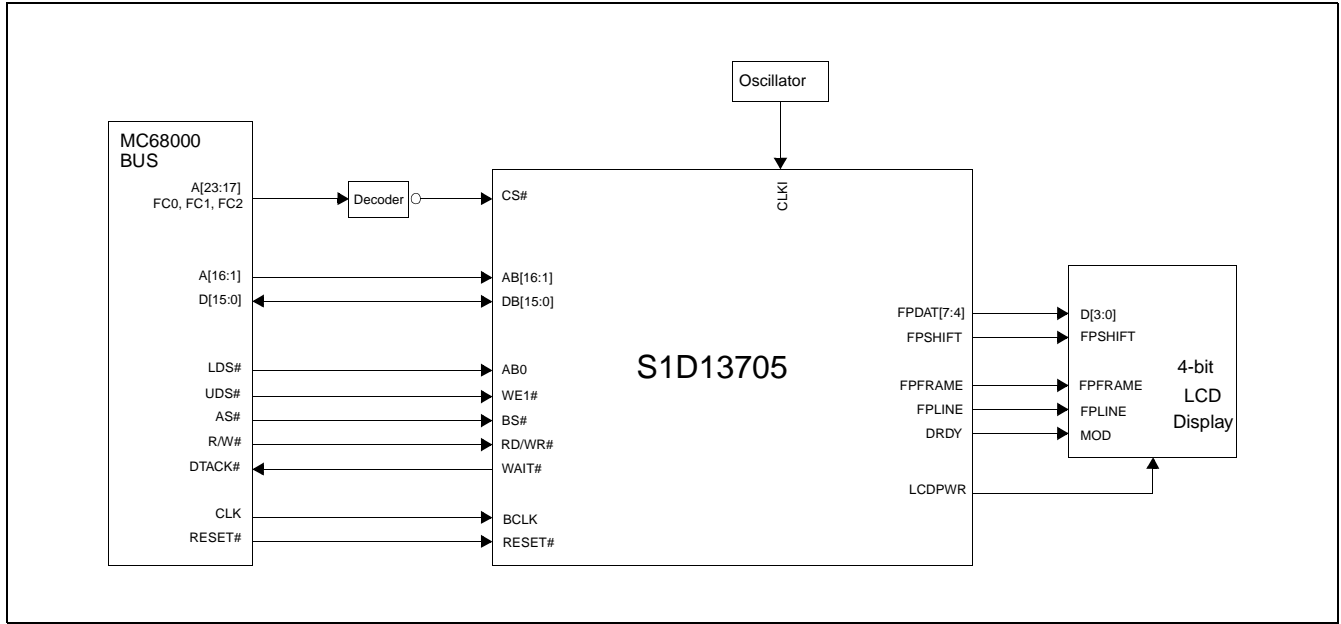

Figure 3-3: Typical System Diagram (M68K #1 Bus)

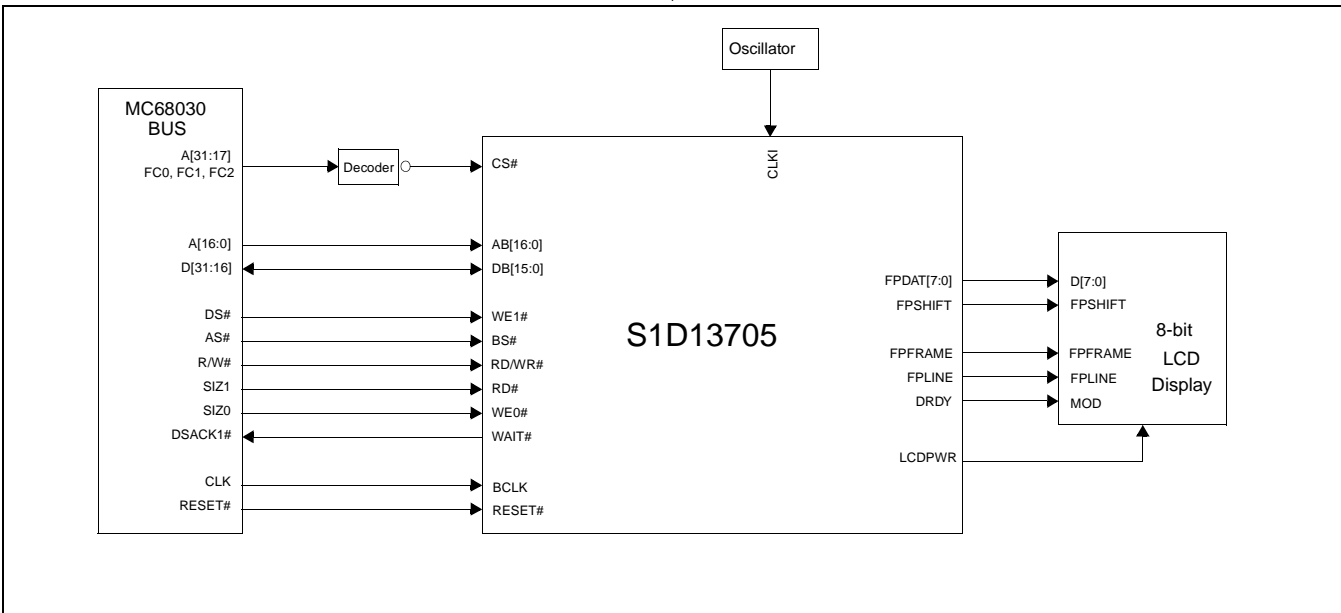

Figure 3-4: Typical System Diagram (M68K #2 Bus)

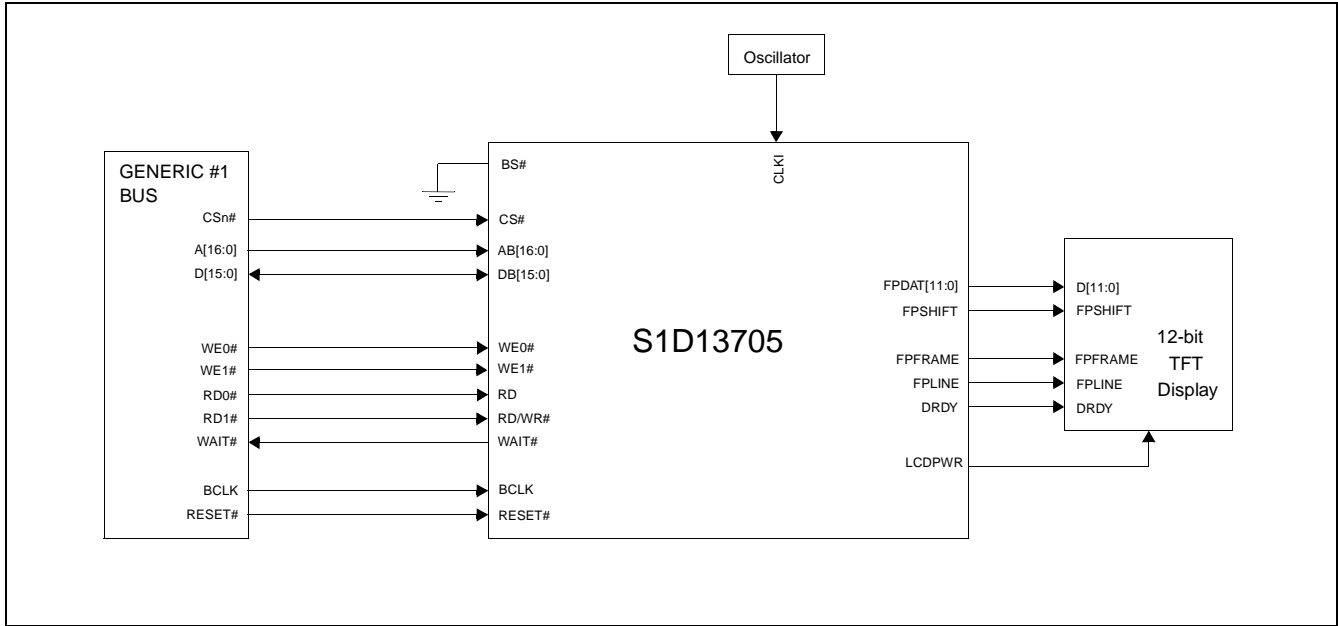

Figure 3-5: Typical System Diagram (Generic #1 Bus)

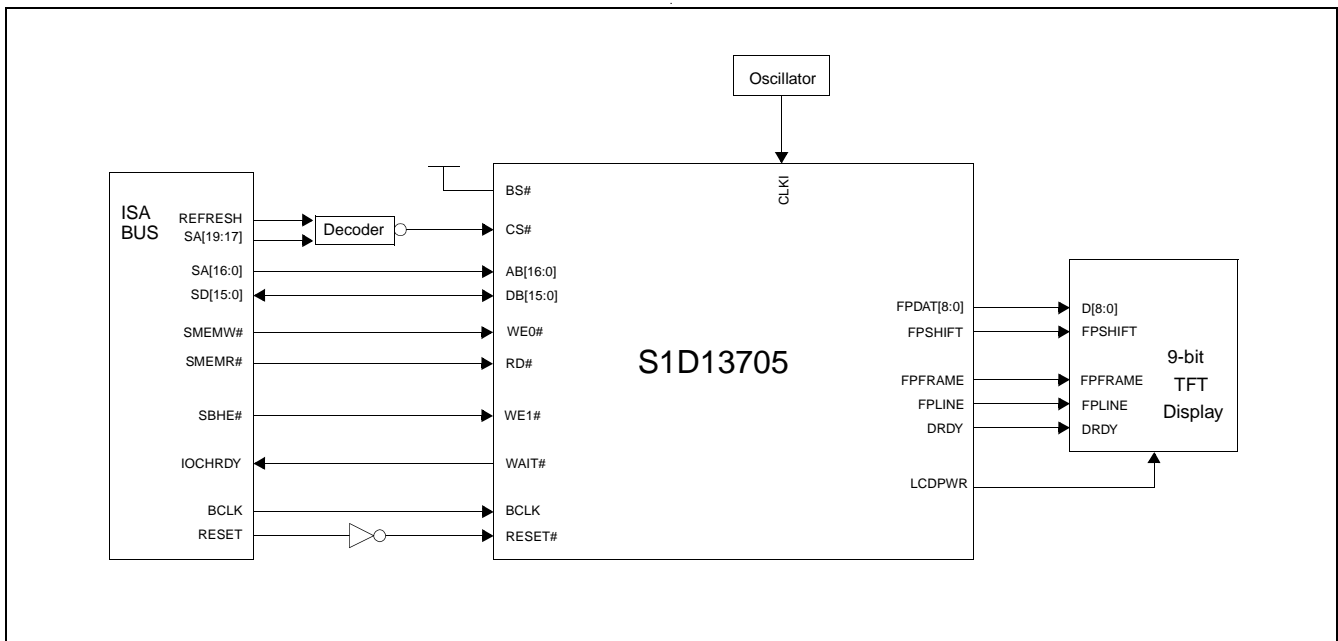

Figure 3-6: Typical System Diagram (Generic #2 Bus - e.g. ISA Bus)

## 4 Functional Block Diagram

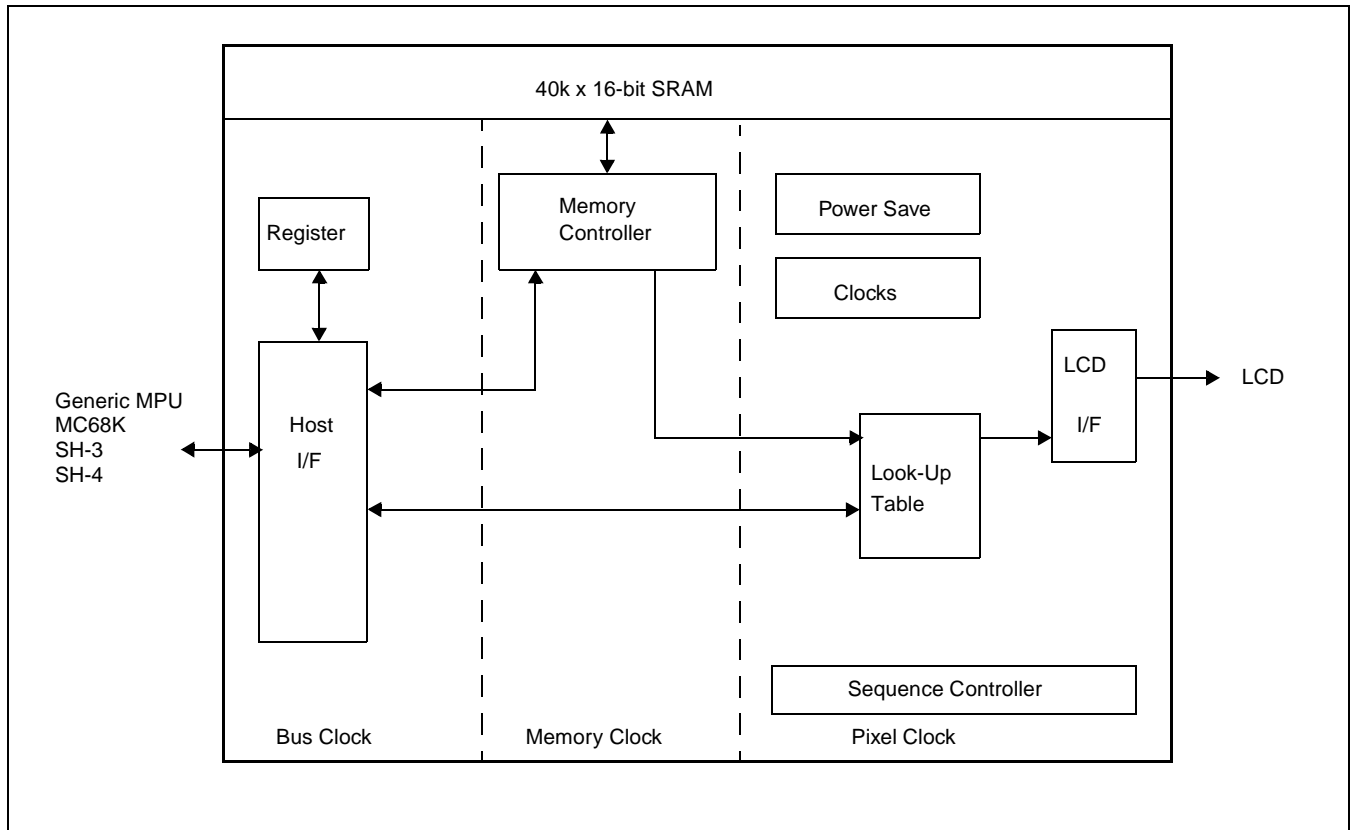

Figure 4-1: System Block Diagram Showing Data Paths

### 4.1 Functional Block Descriptions

#### 4.1.1 Host Interface

The Host Interface provides the means for the CPU/MPU to communicate with the display buffer and internal registers.

#### 4.1.2 Memory Controller

The Memory Controller arbitrates between CPU accesses and display refresh accesses. It also generates the necessary signals to control the SRAM frame buffer.

#### 4.1.3 Sequence Controller

The Sequence Controller controls data flow from the Memory Controller through the Look-Up Table and to the LCD Interface. It also generates memory addresses for display refresh accesses.

#### **4.1.4 Look-Up Table**

The Look-Up Table contains three 256x4 Look-Up Tables or palettes, one for each primary color. In monochrome mode only the green Look-Up Table is used.

#### **4.1.5 LCD Interface**

The LCD Interface performs frame rate modulation for passive LCD panels. It also generates the correct data format and timing control signals for various LCD and TFT/D-TFD panels.

#### **4.1.6 Power Save**

Power Save contains the power save mode circuitry.

# 5 Pins

## 5.1 Pinout Diagram

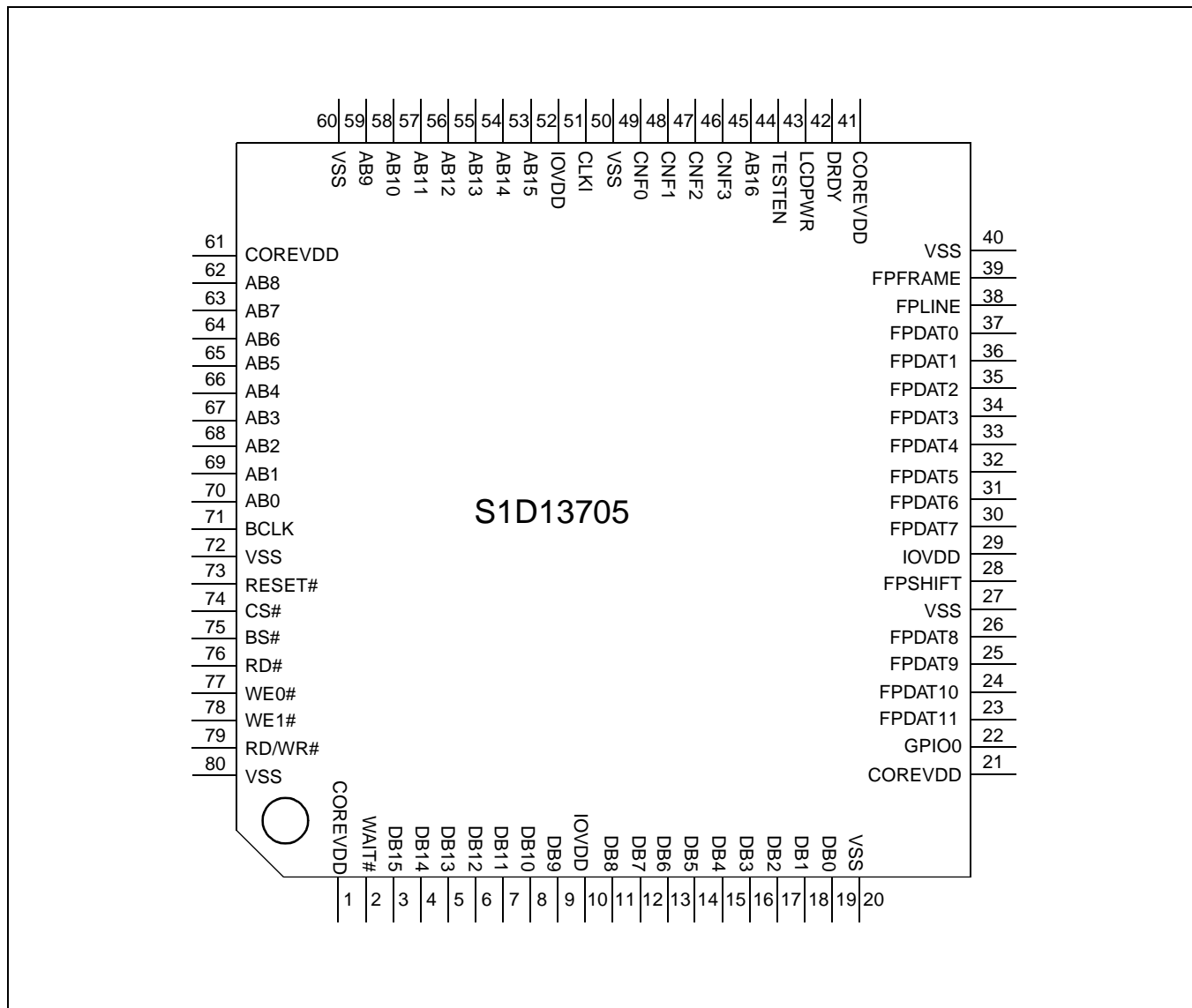

Figure 5-1: Pinout Diagram

**Note**

Package type: 80 pin surface mount QFP14

## 5.2 Pin Description

### Key:

I	=	Input
O	=	Output
IO	=	Bi-Directional (Input/Output)
P	=	Power pin
C	=	CMOS level input
CS	=	CMOS level Schmitt input
COx	=	CMOS output driver, x denotes driver type (see $I_{OL}/I_{OH}$ in Table 6-4: "Output Specifications," on page 25)
TSx	=	Tri-state CMOS output driver, x denotes driver type (see $I_{OL}/I_{OH}$ in Table 6-4: "Output Specifications," on page 25)
CNx	=	CMOS low-noise output driver, x denotes driver type (see $I_{OL}/I_{OH}$ in Table 6-4: "Output Specifications," on page 25)
TEST	=	CMOS level test input with pull down resistor

### 5.2.1 Host Interface

Pin Names	Type	Pin #	Cell	RESET# State	Description
AB0	I	70	CS	Input	This pin has multiple functions. <ul style="list-style-type: none"> <li>For SH-3/SH-4 mode, this pin inputs system address bit 0 (A0).</li> <li>For MC68K #1, this pin inputs the lower data strobe (LDS#).</li> <li>For MC68K #2, this pin inputs system address bit 0 (A0).</li> <li>For Generic #1, this pin inputs system address bit 0 (A0).</li> <li>For Generic #2, this pin inputs system address bit 0 (A0).</li> </ul> See Table 5-2: "Host Bus Interface Pin Mapping," on page 22 for summary.
AB[16:1]	I	45, 53, 54, 55, 56, 57, 58, 59, 62, 63, 64, 65, 66, 67, 68, 69	C	Input	These pins input the system address bits 16 through 1 (A[16:1]).
DB[15:0]	IO	3, 4, 5, 6, 7, 8, 9, 11, 12, 13, 14, 15, 16, 17, 18, 19	C/TS2	Hi-Z	These pins have multiple functions. <ul style="list-style-type: none"> <li>For SH-3/SH-4 mode, these pins are connected to [D15:0].</li> <li>For MC68K #1, these pins are connected to D[15:0].</li> <li>For MC68K #2, these pins are connected to D[31:16] for a 32-bit device (e.g. MC68030) or D[15:0] for a 16-bit device (e.g. MC68340).</li> <li>For Generic #1, these pins are connected to D[15:0].</li> <li>For Generic #2, these pins are connected to D[15:0].</li> </ul> See Table 5-2: "Host Bus Interface Pin Mapping," on page 22 for summary.



Pin Names	Type	Pin #	Cell	RESET# State	Description
WE0#	I	77	CS	Input	<p>This pin has multiple functions.</p> <ul style="list-style-type: none"> <li>For SH-3/SH-4 mode, this pin inputs the write enable signal for the lower data byte (WE0#).</li> <li>For MC68K #1, this pin must be tied to IO <math>V_{DD}</math>.</li> <li>For MC68K #2, this pin inputs the bus size bit 0 (SIZ0).</li> <li>For Generic #1, this pin inputs the write enable signal for the lower data byte (WE0#).</li> <li>For Generic #2, this pin inputs the write enable signal (WE#).</li> </ul> <p>See Table 5-2: "Host Bus Interface Pin Mapping," on page 22 for summary.</p>
WE1#	I	78	CS	Input	<p>This pin has multiple functions.</p> <ul style="list-style-type: none"> <li>For SH-3/SH-4 mode, this pin inputs the write enable signal for the upper data byte (WE1#).</li> <li>For MC68K #1, this pin inputs the upper data strobe (UDS#).</li> <li>For MC68K #2, this pin inputs the data strobe (DS#).</li> <li>For Generic #1, this pin inputs the write enable signal for the upper data byte (WE1#).</li> <li>For Generic #2, this pin inputs the byte enable signal for the high data byte (BHE#).</li> </ul> <p>See Table 5-2: "Host Bus Interface Pin Mapping," on page 22 for summary.</p>
CS#	I	74	C	Input	This pin inputs the chip select signal.
BCLK	I	71	C	Input	This pin inputs the system bus clock.
BS#	I	75	CS	Input	<p>This pin has multiple functions.</p> <ul style="list-style-type: none"> <li>For SH-3/SH-4 mode, this pin inputs the bus start signal (BS#).</li> <li>For MC68K #1, this pin inputs the address strobe (AS#).</li> <li>For MC68K #2, this pin inputs the address strobe (AS#).</li> <li>For Generic #1, this pin must be tied to <math>V_{SS}</math>.</li> <li>For Generic #2, this pin must be tied to IO <math>V_{DD}</math>.</li> </ul> <p>See Table 5-2: "Host Bus Interface Pin Mapping," on page 22 for summary.</p>
RD/WR#	I	79	CS	Input	<p>This pin has multiple functions.</p> <ul style="list-style-type: none"> <li>For SH-3/SH-4 mode, this pin inputs the RD/WR# signal. The S1D13705 needs this signal for early decode of the bus cycle.</li> <li>For MC68K #1, this pin inputs the R/W# signal.</li> <li>For MC68K #2, this pin inputs the R/W# signal.</li> <li>For Generic #1, this pin inputs the read command for the upper data byte (RD1#).</li> <li>For Generic #2, this pin must be tied to IO <math>V_{DD}</math>.</li> </ul> <p>See Table 5-2: "Host Bus Interface Pin Mapping," on page 22 for summary.</p>

Pin Names	Type	Pin #	Cell	RESET# State	Description
RD#	I	76	CS	Input	<p>This pin has multiple functions.</p> <ul style="list-style-type: none"> <li>For SH-3/SH-4 mode, this pin inputs the read signal (RD#).</li> <li>For MC68K #1, this pin must be tied to IO <math>V_{DD}</math>.</li> <li>For MC68K #2, this pin inputs the bus size bit 1 (SIZ1).</li> <li>For Generic #1, this pin inputs the read command for the lower data byte (RD0#).</li> <li>For Generic #2, this pin inputs the read command (RD#).</li> </ul> <p>See Table 5-2: "Host Bus Interface Pin Mapping," on page 22 for summary.</p>
WAIT#	O	2	TS2	Hi-Z	<p>This pin has multiple functions.</p> <ul style="list-style-type: none"> <li>For SH-3 mode, this pin outputs the wait request signal (WAIT#).</li> <li>For SH-4 mode, this pin outputs the device ready signal (RDY#).</li> <li>For MC68K #1, this pin outputs the data transfer acknowledge signal (DTACK#).</li> <li>For MC68K #2, this pin outputs the data transfer and size acknowledge bit 1 (DSACK1#).</li> <li>For Generic #1, this pin outputs the wait signal (WAIT#).</li> <li>For Generic #2, this pin outputs the wait signal (WAIT#).</li> </ul> <p>See Table 5-2: "Host Bus Interface Pin Mapping," on page 22 for summary.</p>
RESET#	I	73	CS	0	Active low input to set all internal registers to the default state and to force all signals to their inactive states.

## 5.2.2 LCD Interface

Pin Name	Type	Pin #	Cell	RESET# State	Description
FPDAT[7:0]	O	30, 31, 32, 33, 34, 35, 36, 37	CN3	0	Panel Data
FPDAT[10:8]	O, IO	24, 25, 26	CN3	Input	<p>These pins have multiple functions.</p> <ul style="list-style-type: none"> <li>Panel Data bits [10:8] for TFT/D-TFD panels.</li> <li>General Purpose Input/Output pins GPIO[3:1].</li> </ul> <p>These pins should be connected to IO <math>V_{DD}</math> when unused. See Table 5-3: "LCD Interface Pin Mapping," on page 23 for summary.</p>
FPDAT11	O, IO	23	CN3	Input	<p>This pin has multiple functions.</p> <ul style="list-style-type: none"> <li>Panel Data bit 11 for TFT/D-TFD panels.</li> <li>General Purpose Input/Output pin GPIO4.</li> <li>Inverse Video select pin.</li> </ul> <p>This pin should be connected to IO <math>V_{DD}</math> when unused. See Table 5-3: "LCD Interface Pin Mapping," on page 23 for summary.</p>
FPFRAME	O	39	CN3	0	Frame Pulse

Pin Name	Type	Pin #	Cell	RESET# State	Description
FPLINE	O	38	CN3	0	Line Pulse
FPSHIFT	O	28	CN3	0	Shift Clock
LCDPWR	O	43	CO1	0	Active high LCD Power Control
DRDY	O	42	CN3	0	This pin has multiple functions. <ul style="list-style-type: none"> <li>TFT/D-TFD Display Enable (DRDY).</li> <li>LCD Backplane Bias (MOD).</li> <li>Second Shift Clock (FPSHIFT2).</li> </ul> See Table 5-3: "LCD Interface Pin Mapping," on page 23 for summary.

### 5.2.3 Clock Input

Pin Name	Type	Pin #	Driver	Description
CLKI	I	51	C	Input Clock

### 5.2.4 Miscellaneous

Pin Name	Type	Pin #	Cell	RESET# State	Description
CNF[3:0]	I	46, 47, 48, 49	C	As set by hardware	These inputs are used to configure the S1D13705 - see Table 5-1: "Summary of Power On/Reset Options," on page 22. Must be connected directly to IO $V_{DD}$ or $V_{SS}$ .
GPIO0	IO, I	22	CS/ TS1	Input	This pin has multiple functions - see REG[03h] bit 2. <ul style="list-style-type: none"> <li>General Purpose Input/Output pin.</li> <li>Hardware Power Save.</li> </ul>
TESTEN	I	44	TEST	pulled low	Test Enable input. This input must be connected to $V_{SS}$ .

### 5.2.5 Power Supply

Pin Name	Type	Pin #	Driver	Description
COREVDD	P	1, 21, 41, 61	P	Core $V_{DD}$
IOVDD	P	10, 29, 52	P	IO $V_{DD}$
VSS	P	20, 27, 40, 50, 60, 72, 80	P	Common $V_{SS}$

## 5.3 Summary of Configuration Options

Table 5-1: Summary of Power On/Reset Options

Configuration Pin	Power On/Reset State					
CNF[3:0]	Select host bus interface as follows:					
	<b>CNF3</b>	<b>CNF2</b>	<b>CNF1</b>	<b>CNF0</b>	<b>BS#</b>	<b>Host Bus</b>
	1	0	0	0	X	SH-4 interface Big Endian
	0	0	0	0	X	SH-4 interface Little Endian
	1	0	0	1	X	SH-3 interface Big Endian
	0	0	0	1	X	SH-3 interface Little Endian
	X	0	1	0	X	reserved
	1	0	1	1	X	MC68K #1, 16-bit Big Endian
	0	0	1	1	X	reserved
	X	1	0	0	X	reserved
	1	1	0	1	X	MC68K #2, 16-bit Big Endian
	0	1	0	1	X	reserved
	X	1	1	0	0	reserved
	X	1	1	0	1	reserved
	1	1	1	1	0	Generic #1, 16-bit Big Endian
0	1	1	1	0	Generic #1, 16-bit Little Endian	
1	1	1	1	1	reserved	
0	1	1	1	1	Generic #2, 16-bit Little Endian	

## 5.4 Host Bus Interface Pin Mapping

Table 5-2: Host Bus Interface Pin Mapping

S1D13705 Pin Names	SH-3	SH-4	MC68K #1	MC68K #2	Generic #1	Generic #2
AB[16:1]	A[16:1]	A[16:1]	A[16:1]	A[16:1]	A[16:1]	A[16:1]
AB0	A0	A0	LDS#	A0	A0	A0
DB[15:0]	D[15:0]	D[15:0]	D[15:0]	D[31:16]	D[15:0]	D[15:0]
WE1#	WE1#	WE1#	UDS#	DS#	WE1#	BHE#
CS#	CSn#	CSn#	External Decode	External Decode	External Decode	External Decode
BCLK	CKIO	CKIO	CLK	CLK	BCLK	BCLK
BS#	BS#	BS#	AS#	AS#	connect to V <sub>SS</sub>	connect to IO V <sub>DD</sub>
RD/WR#	RD/WR#	RD/WR#	R/W#	R/W#	RD1#	connect to IO V <sub>DD</sub>
RD#	RD#	RD#	connect to IO V <sub>DD</sub>	SIZ1	RD0#	RD#
WE0#	WE0#	WE0#	connect to IO V <sub>DD</sub>	SIZ0	WE0#	WE#
WAIT#	WAIT#	RDY#	DTACK#	DSACK1#	WAIT#	WAIT#
RESET#	RESET#	RESET#	RESET#	RESET#	RESET#	RESET#

## 5.5 LCD Interface Pin Mapping

Table 5-3: LCD Interface Pin Mapping

S1D13705 Pin Name	Monochrome Passive Panel			Color Passive Panel				Color TFT/D-TFD	
	4-bit Single	8-bit Single	8-bit Dual	4-bit Single	8-bit Single Format 1	8-bit Single Format 2	8-bit Dual	9-bit	12-bit
FPFRAME	FPFRAME								
FPLINE	FPLINE								
FPSHIFT	FPSHIFT								
DRDY	MOD	MOD	MOD	MOD	FPSHIFT2	MOD	MOD	DRDY	
FPDAT0	driven 0	D0	LD0	driven 0	D0	D0	LD0	R2	R3
FPDAT1	driven 0	D1	LD1	driven 0	D1	D1	LD1	R1	R2
FPDAT2	driven 0	D2	LD2	driven 0	D2	D2	LD2	R0	R1
FPDAT3	driven 0	D3	LD3	driven 0	D3	D3	LD3	G2	G3
FPDAT4	D0	D4	UD0	D0	D4	D4	UD0	G1	G2
FPDAT5	D1	D5	UD1	D1	D5	D5	UD1	G0	G1
FPDAT6	D2	D6	UD2	D2	D6	D6	UD2	B2	B3
FPDAT7	D3	D7	UD3	D3	D7	D7	UD3	B1	B2
FPDAT8	GPIO1	GPIO1	GPIO1	GPIO1	GPIO1	GPIO1	GPIO1	B0	B1
FPDAT9	GPIO2	GPIO2	GPIO2	GPIO2	GPIO2	GPIO2	GPIO2	GPIO2	R0
FPDAT10	GPIO3	GPIO3	GPIO3	GPIO3	GPIO3	GPIO3	GPIO3	GPIO3	G0
FPDAT11	GPIO4/ Hardware Video Invert	GPIO4/ Hardware Video Invert	GPIO4/ Hardware Video Invert	GPIO4/ Hardware Video Invert	GPIO4/ Hardware Video Invert	GPIO4/ Hardware Video Invert	GPIO4/ Hardware Video Invert	GPIO4	B0

**Note**

1. Unused GPIO pins must be connected to IO  $V_{DD}$ .
2. Hardware Video Invert is enabled on FPDAT11 by REG[02h] bit 1.

## 6 D.C. Characteristics

Table 6-1: Absolute Maximum Ratings

Symbol	Parameter	Rating	Units
Core V <sub>DD</sub>	Supply Voltage	V <sub>SS</sub> - 0.3 to 4.0	V
IO V <sub>DD</sub>	Supply Voltage	Core V <sub>DD</sub> to 7.0	V
V <sub>IN</sub>	Input Voltage	V <sub>SS</sub> - 0.3 to IO V <sub>DD</sub> + 0.5	V
V <sub>OUT</sub>	Output Voltage	V <sub>SS</sub> - 0.3 to IO V <sub>DD</sub> + 0.5	V
T <sub>STG</sub>	Storage Temperature	-65 to 150	°C
T <sub>SOL</sub>	Solder Temperature/Time	260 for 10 sec. max at lead	°C

Table 6-2: Recommended Operating Conditions for Core V<sub>DD</sub> = 3.3V ± 10%

Symbol	Parameter	Condition	Min	Typ	Max	Units
Core V <sub>DD</sub>	Supply Voltage	V <sub>SS</sub> = 0 V	2.7	3.0/3.3	3.6	V
IO V <sub>DD</sub>	Supply Voltage	V <sub>SS</sub> = 0 V, IO V <sub>DD</sub> ≥ Core V <sub>DD</sub>	2.7	3.0/3.3/5.0	5.5	V
V <sub>IN</sub>	Input Voltage		V <sub>SS</sub>		IO V <sub>DD</sub>	V
T <sub>OPR</sub>	Operating Temperature		-40	25	85	°C

Table 6-3: Input Specifications

Symbol	Parameter	Condition	Min	Typ	Max	Units
V <sub>IL</sub>	Low Level Input Voltage CMOS inputs	IO V <sub>DD</sub> = 3.0 3.3 5.0			0.8 0.8 1.0	V
V <sub>IH</sub>	High Level Input Voltage CMOS inputs	IO V <sub>DD</sub> = 3.0 3.3 5.0	1.9 2.0 3.5			V
V <sub>T+</sub>	Positive-going Threshold CMOS Schmitt inputs	IO V <sub>DD</sub> = 3.0 3.3 5.0	1.0 1.1 2.0		2.3 2.4 4.0	V
V <sub>T-</sub>	Negative-going Threshold CMOS Schmitt inputs	IO V <sub>DD</sub> = 3.0 3.3 5.0	0.5 0.6 0.8		1.7 1.8 3.1	V
I <sub>IZ</sub>	Input Leakage Current	V <sub>DD</sub> = Max V <sub>IH</sub> = V <sub>DD</sub> V <sub>IL</sub> = V <sub>SS</sub>	-1		1	μA
C <sub>IN</sub>	Input Pin Capacitance				10	pF

Table 6-4: Output Specifications

Symbol	Parameter	Condition	Min	Typ	Max	Units
$I_{OL}$ (3.0V)	Low Level Output Current	IO $V_{DD} = 3.0V$ $V_O = 0.4V$ , Type = 1 2 3		1.8 5 10		mA
$I_{OL}$ (3.3V)	Low Level Output Current	IO $V_{DD} = 3.3V$ $V_O = 0.4V$ , Type = 1 2 3		2 6 12		mA
$I_{OL}$ (5.0V)	Low Level Output Current	IO $V_{DD} = 5.0V$ $V_O = 0.4V$ , Type = 1 2 3		3 8 12		mA
$I_{OH}$ (3.0V)	High Level Output Current	IO $V_{DD} = 3.0V$ $V_O = IO V_{DD} - 0.4V$ , Type = 1 2 3		-1.8 -5 -10		mA
$I_{OH}$ (3.3V)	High Level Output Current	IO $V_{DD} = 3.3V$ $V_O = IO V_{DD} - 0.4V$ , Type = 1 2 3		-2 -6 -12		mA
$I_{OH}$ (5.0V)	High Level Output Current	IO $V_{DD} = 5.0V$ $V_O = IO V_{DD} - 0.4V$ , Type = 1 2 3		-3 -8 -12		mA
$V_{OL}$	Low Level Output Voltage	$I = I_{OL}$			0.4	V
$V_{OH}$	High Level Output Voltage	$I = I_{OH}$	IO $V_{DD} - 0.4$			V
$I_{OZ}$	Output Leakage Current	$V_{DD} = MAX$ $V_{OH} = V_{DD}$ $V_{OL} = V_{SS}$	-1		1	$\mu A$
$C_{OUT}$	Output Pin Capacitance				10	pF
$C_{BID}$	Bidirectional Pin Capacitance				10	pF

## 7 A.C. Characteristics

Conditions: IO  $V_{DD} = 2.7\text{ V to }5.0\text{ V}$

$T_A = -40^\circ\text{ C to }85^\circ\text{ C}$

$T_{\text{rise}}$  and  $T_{\text{fall}}$  for all inputs must be  $\leq 5\text{ nsec}$  (10% ~ 90%)

$C_L = 60\text{ pF}$  (Bus/MPU Interface)

$C_L = 60\text{ pF}$  (LCD Panel Interface)

### 7.1 Bus Interface Timing

#### 7.1.1 SH-4 Interface Timing

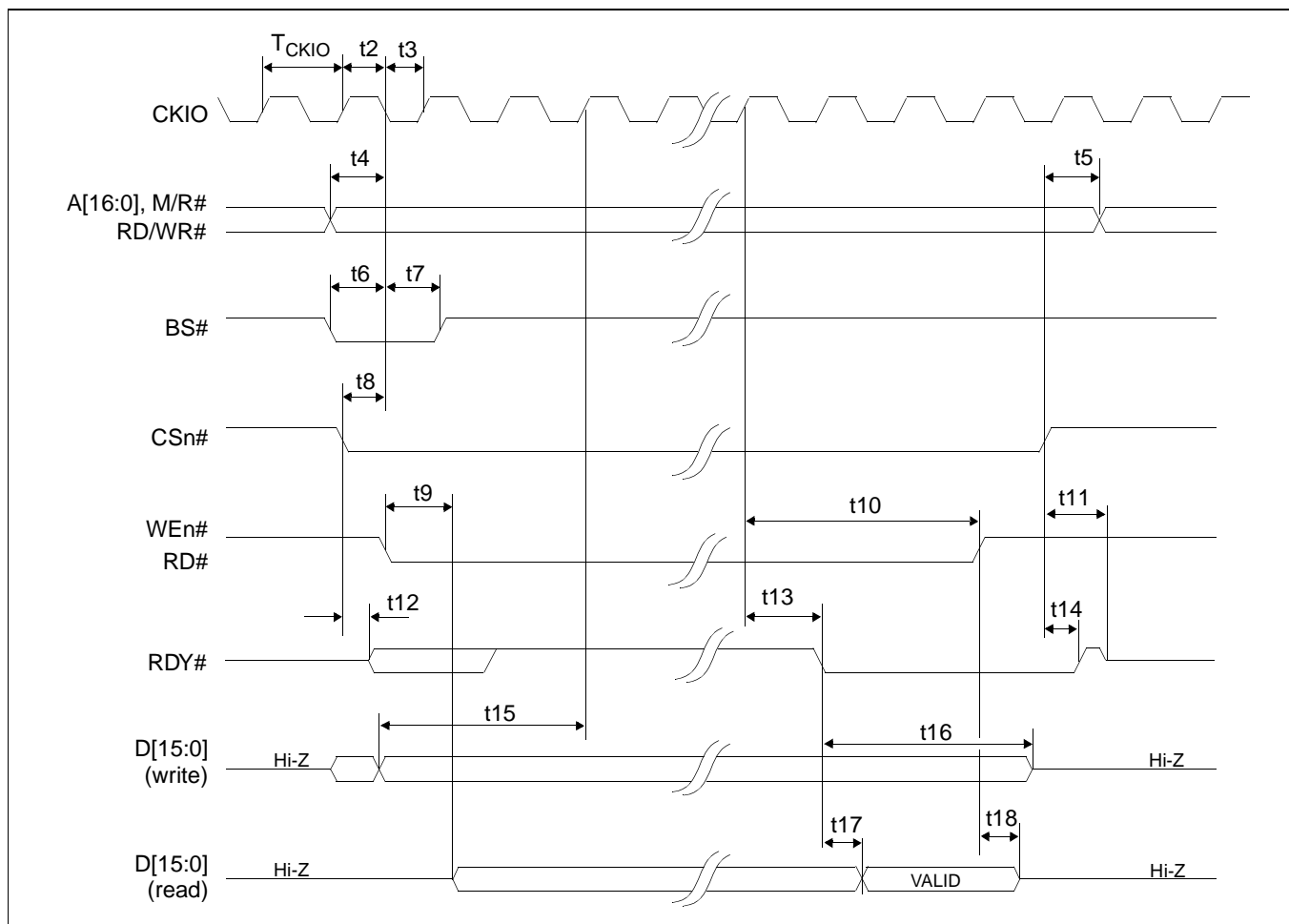

Figure 7-1: SH-4 Timing

#### Note

The SH-4 Wait State Control Register for the area in which the S1D13705 resides must be set to a non-zero value. The SH-4 read-to-write cycle transition must be set to a non-zero value (with reference to BUSCLK).



Table 7-1: SH-4 Timing

Symbol	Parameter	Min	Max	Units
$f_{CKIO}$	Bus Clock frequency		50	MHz
$T_{CKIO}$	Bus Clock period	$1/f_{CKIO}$		
t2	Bus Clock pulse width low	8		ns
t3	Bus Clock pulse width high	8		ns
t4	A[16:0], RD/WR# setup to CKIO	0		ns
t5	A[16:0], RD/WR# hold from CS#	0		ns
t6	BS# setup	5		ns
t7	BS# hold	5		ns
t8	CSn# setup	0		ns
t9	Falling edge RD# to DB[15:0] driven		25	ns
t10	CKIO to WE#, RD# high	$1.5T_{CKIO}$		
t11	Rising edge CSn# to RDY# high impedance		$T_{CKIO}$	
t12	Falling edge CSn# to RDY# driven		20	ns
t13	CKIO to RDY# low		20	ns
t14	Rising edge CSn# to RDY# high		16	ns
t15	DB[15:0] setup to 2 <sup>nd</sup> CKIO after BS# (write cycle)	0		ns
t16	DB[15:0] hold (write cycle)	0		ns
t17	RDY# falling edge to DB[15:0] valid (read cycle)		7	ns
t18	Rising edge RD# to DB[15:0] high impedance (read cycle)		10	ns

**Note**

CKIO may be turned off (held low) between accesses - see Section 13.5, “Turning Off BCLK Between Accesses” on page 84

## 7.1.2 SH-3 Interface Timing

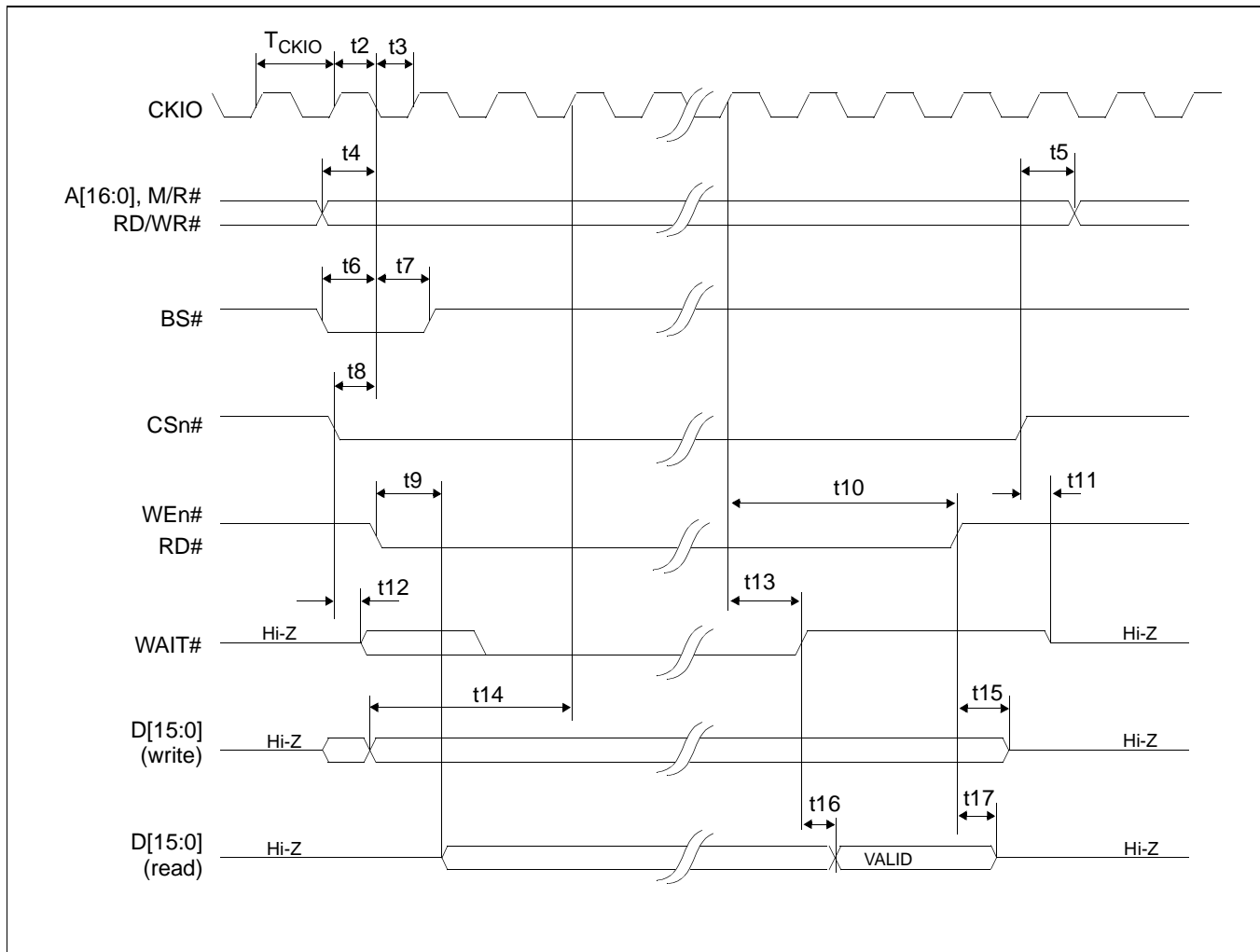

Figure 7-2: SH-3 Bus Timing

### Note

The SH-3 Wait State Control Register for the area in which the S1D13705 resides must be set to a non-zero value.

Table 7-2: SH-3 Bus Timing

Symbol	Parameter	Min	Max <sup>a</sup>	Units
$f_{CKIO}$	Bus Clock frequency		50	MHz
$T_{CKIO}$	Bus Clock period	$1/f_{CKIO}$		
t2	Bus Clock pulse width low	8		ns
t3	Bus Clock pulse width high	8		ns
t4	A[16:0], RD/WR# setup to CKIO	0		ns
t5	A[16:0], RD/WR# hold from CS#	0		ns
t6	BS# setup	5		ns
t7	BS# hold	5		ns
t8	CSn# setup	0		ns
t9	Falling edge RD# to DB[15:0] driven		25	ns
t10	CKIO to WEn#, RD# high	$1.5T_{CKIO}$		
t11	Rising edge CSn# to WAIT# high impedance		10	ns
t12	Falling edge CSn# to WAIT# driven		15	ns
t13	CKIO to WAIT# delay		20	ns
t14	DB[15:0] setup to 2 <sup>nd</sup> CKIO after BS# (write cycle)	0		ns
t15	DB[15:0] hold from rising edge of WEn# (write cycle)	0		ns
t16	WAIT# rising edge to DB[15:0] valid (read cycle)		6	ns
t17	Rising edge RD# to DB[15:0] high impedance (read cycle)		10	ns

<sup>a</sup> One Software WAIT State Required

**Note**

CKIO may be turned off (held low) between accesses - see Section 13.5, “Turning Off BCLK Between Accesses” on page 84

### 7.1.3 Motorola MC68K #1 Interface Timing

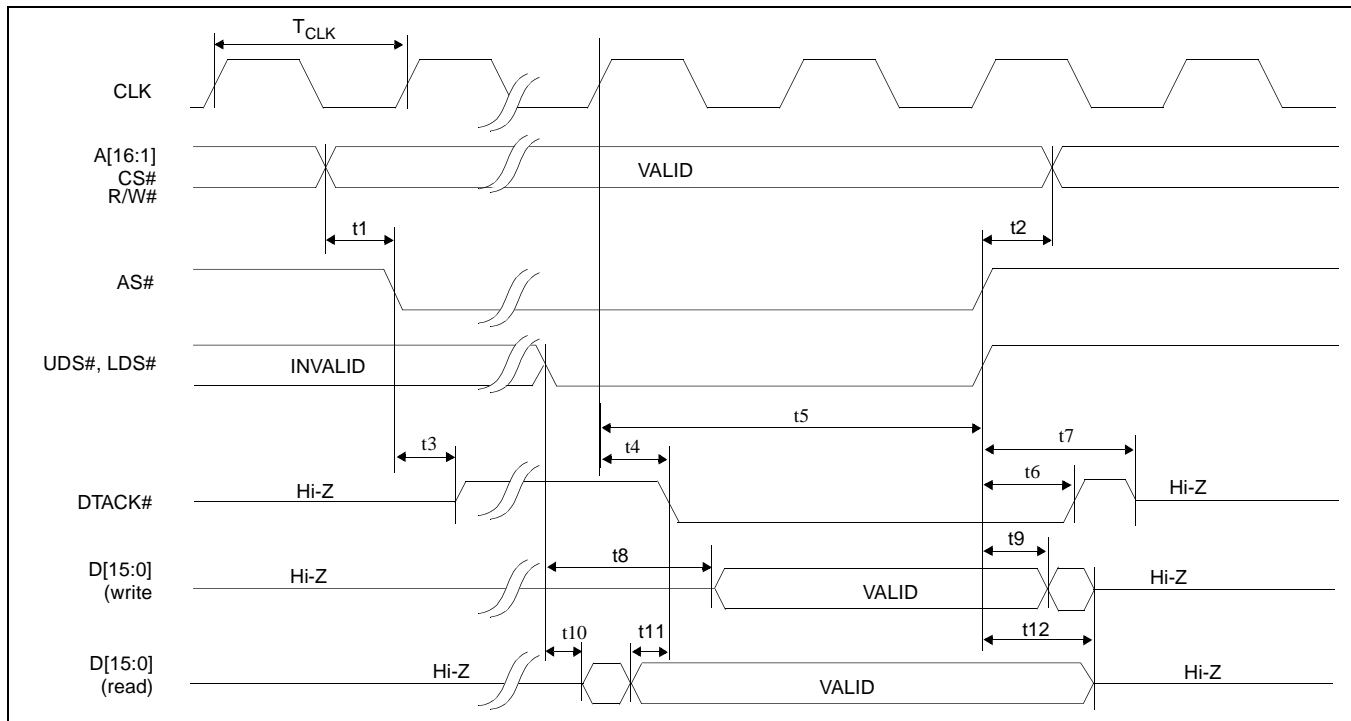

Figure 7-3: MC68K #1 Bus Timing (MC68000)

Table 7-3: MC68K #1 Bus Timing (MC68000)

Symbol	Parameter	Min	Max	Units
$f_{CLK}$	Bus Clock Frequency		33	MHz
$T_{CLK}$	Bus Clock period	$1/f_{CLK}$		
$t_1$	A[16:1], CS# valid before AS# falling edge	0		ns
$t_2$	A[16:1], CS# hold from AS# rising edge	0		ns
$t_3$	AS# low to DTACK# driven high		16	ns
$t_4$	CLK to DTACK# low		15	ns
$t_5$	CLK to AS#, UDS#, LDS# high	$1T_{CLK}$		
$t_6$	AS# high to DTACK# high		20	ns
$t_7$	AS# high to DTACK# high impedance		$T_{CLK}$	
$t_8$	UDS#, LDS# falling edge to D[15:0] valid (write cycle)		$T_{CLK}$	
$t_9$	D[15:0] hold from AS# rising edge (write cycle)	0		ns
$t_{10}$	UDS#, LDS# falling edge to D[15:0] driven (read cycle)		15	ns
$t_{11}$	D[15:0] valid to DTACK# falling edge (read cycle)	0		ns
$t_{12}$	UDS#, LDS# rising edge to D[15:0] high impedance		10	ns

#### Note

CLK may be turned off (held low) between accesses - see Section 13.5, "Turning Off BCLK Between Accesses" on page 84

### 7.1.4 Motorola MC68K #2 Interface Timing

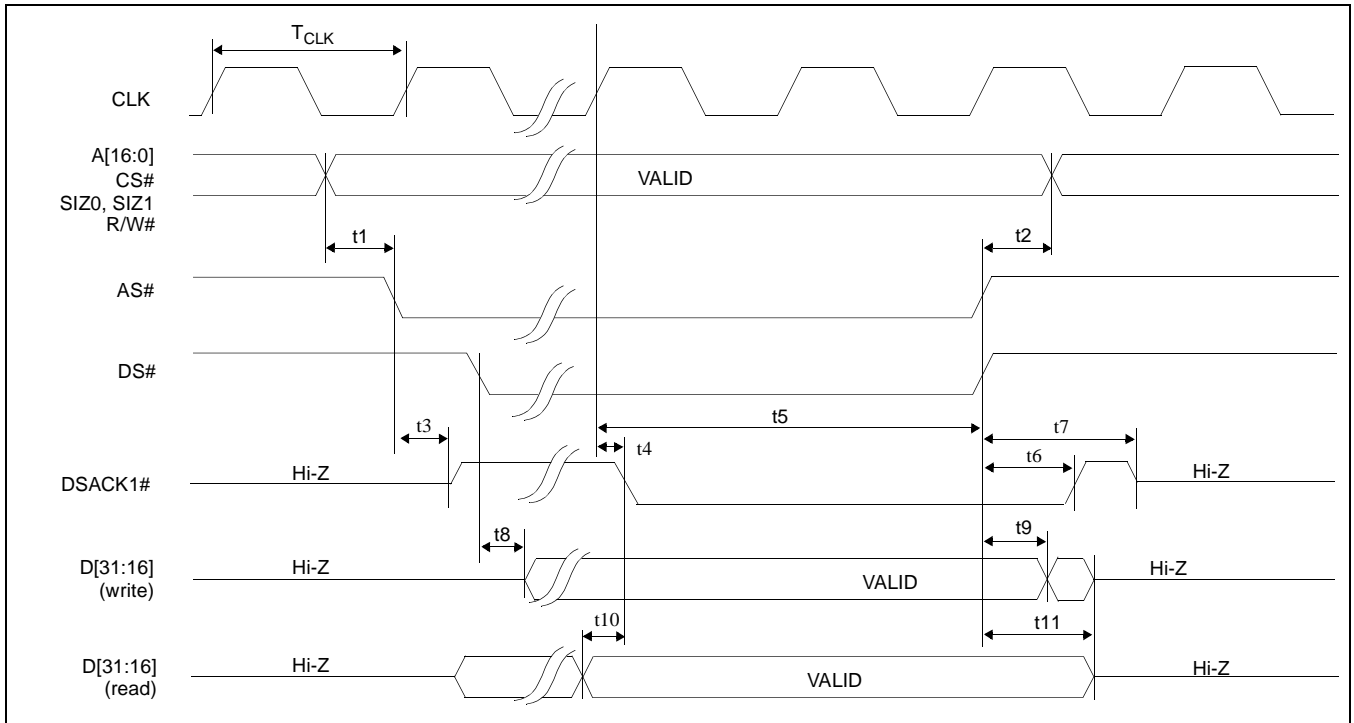

Figure 7-4: MC68K #2 Timing (MC68030)

Table 7-4: MC68K #2 Timing (MC68030)

Symbol	Parameter	Min	Max	Units
$f_{CLK}$	Bus Clock frequency		33	MHz
$T_{CLK}$	Bus Clock period	$1/f_{CLK}$		
$t_1$	A[16:0], CS#, SIZ0, SIZ1 valid before AS# falling edge	0		ns
$t_2$	A[16:0], CS#, SIZ0, SIZ1 hold from AS#, DS# rising edge	0		ns
$t_3$	AS# low to DSACK1# driven high		22	ns
$t_4$	CLK to DSACK1# low		18	ns
$t_5$	CLK to AS#, DS# high	$1T_{CLK}$		ns
$t_6$	AS# high to DSACK1# high		20	ns
$t_7$	AS# high to DSACK1# high impedance		$T_{CLK}$	
$t_8$	DS# falling edge to D[31:16] valid (write cycle)		$T_{CLK}/2$	
$t_9$	AS#, DS# rising edge to D[31:16] invalid (write cycle)	0		ns
$t_{10}$	D[31:16] valid to DSACK1# low (read cycle)	0		ns
$t_{11}$	AS#, DS# rising edge to D[31:16] high impedance		20	ns

**Note**

CLK may be turned off (held low) between accesses - see Section 13.5, “Turning Off BCLK Between Accesses” on page 84

## 7.1.5 Generic #1 Interface Timing

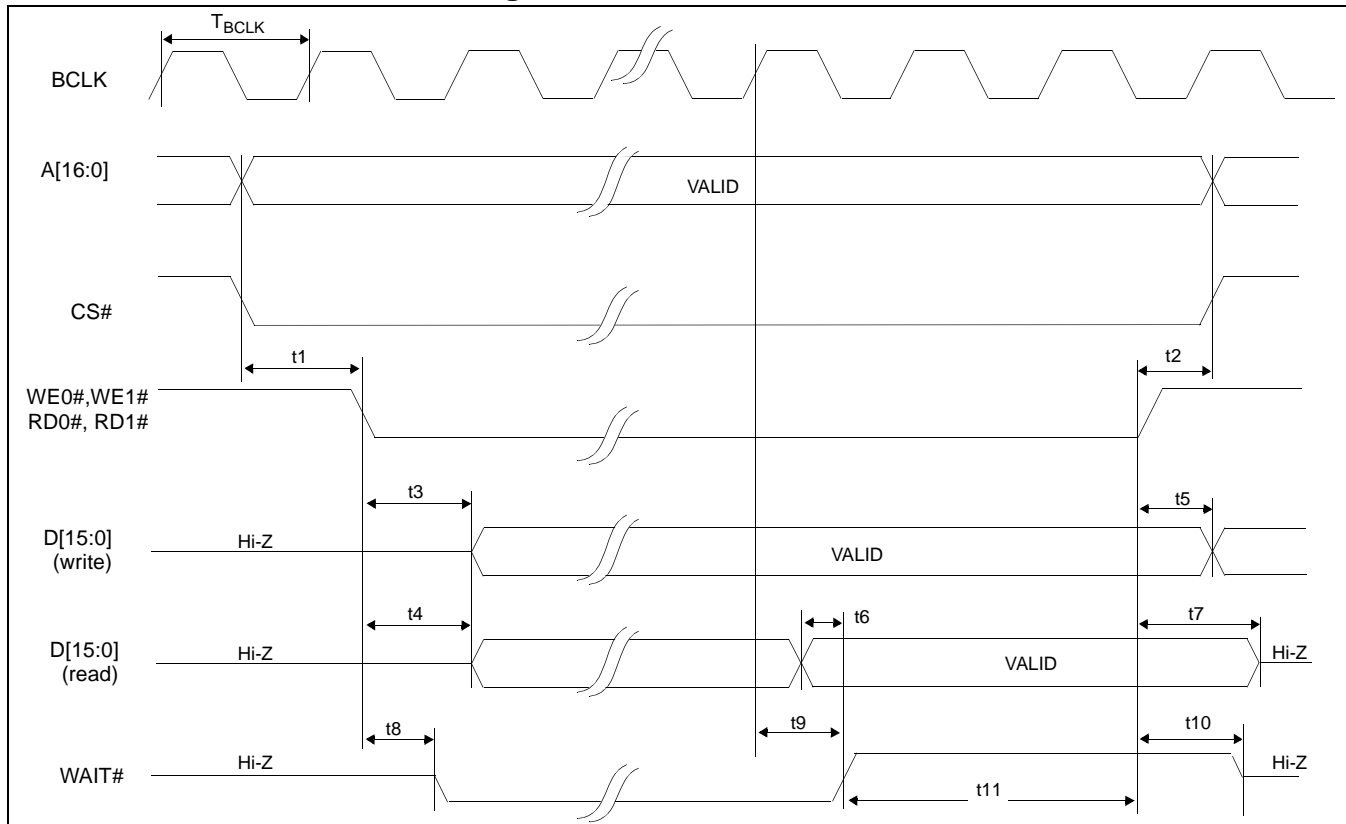

Figure 7-5: Generic #1 Timing

Table 7-5: Generic #1 Timing

Symbol	Parameter	Min	Max	Units
$f_{BCLK}$	Bus Clock frequency		50	MHz
$T_{BCLK}$	Bus Clock period	$1/f_{BCLK}$		MHz
$t1$	$A[16:0]$ , $CS\#$ valid to $WE0\#, WE1\#$ low (write cycle) or $RD0\#, RD1\#$ low (read cycle)	0		ns
$t2$	$WE0\#, WE1\#$ high (write cycle) or $RD0\#, RD1\#$ high (read cycle) to $A[16:0]$ , $CS\#$ invalid	0		ns
$t3$	$WE0\#, WE1\#$ low to $D[15:0]$ valid (write cycle)		$T_{BCLK}$	
$t4$	$RD0\#, RD1\#$ low to $D[15:0]$ driven (read cycle)		17	ns
$t5$	$WE0\#, WE1\#$ high to $D[15:0]$ invalid (write cycle)	0		ns
$t6$	$D[15:0]$ valid to $WAIT\#$ high (read cycle)	0		ns
$t7$	$RD0\#, RD1\#$ high to $D[15:0]$ high impedance (read cycle)		10	ns
$t8$	$WE0\#, WE1\#$ low (write cycle) or $RD0\#, RD1\#$ low (read cycle) to $WAIT\#$ driven low		16	ns
$t9$	$BCLK$ to $WAIT\#$ high		16	ns
$t10$	$WE0\#, WE1\#$ high (write cycle) or $RD0\#, RD1\#$ high (read cycle) to $WAIT\#$ high impedance		16	ns
$t11$	$WAIT\#$ high to $WE0\#, WE1\#, RD0\#, RD1\#$ high	$1T_{BCLK}$		

### Note

BCLK may be turned off (held low) between accesses - see Section 13.5, “Turning Off BCLK Between Accesses” on page 84

## 7.1.6 Generic #2 Interface Timing

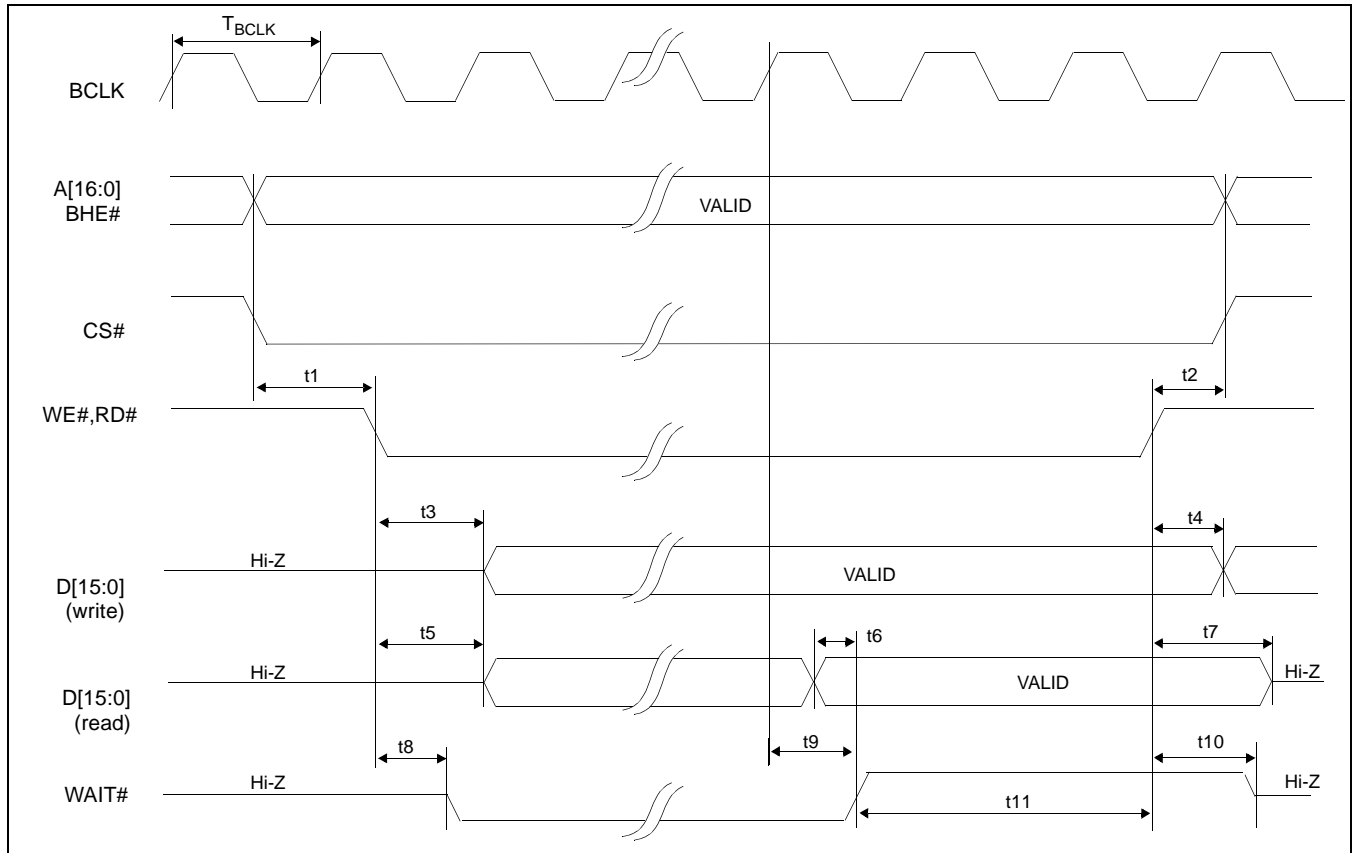

Figure 7-6: Generic #2 Timing

Table 7-6: Generic #2 Timing

Symbol	Parameter	Min	Max	Units
$f_{BCLK}$	Bus Clock frequency		50	MHz
$T_{BCLK}$	Bus Clock period	$1/f_{BCLK}$		
$t_1$	A[16:0], BHE#, CS# valid to WE#, RD# low	0		ns
$t_2$	WE#, RD# high to A[16:0], BHE#, CS# invalid	0		ns
$t_3$	WE# low to D[15:0] valid (write cycle)		$T_{BCLK}$	
$t_4$	WE# high to D[15:0] invalid (write cycle)	0		ns
$t_5$	RD# low to D[15:0] driven (read cycle)		16	ns
$t_6$	D[15:0] valid to WAIT# high (read cycle)	0		ns
$t_7$	RD# high to D[15:0] high impedance (read cycle)		10	ns
$t_8$	WE#, RD# low to WAIT# driven low		14	ns
$t_9$	BCLK to WAIT# high		10	ns
$t_{10}$	WE#, RD# high to WAIT# high impedance		11	ns
$t_{11}$	WAIT# high to WE#, RD# high	$1T_{BCLK}$		

### Note

BCLK may be turned off (held low) between accesses - see Section 13.5, “Turning Off BCLK Between Accesses” on page 84

## 7.2 Clock Input Requirements

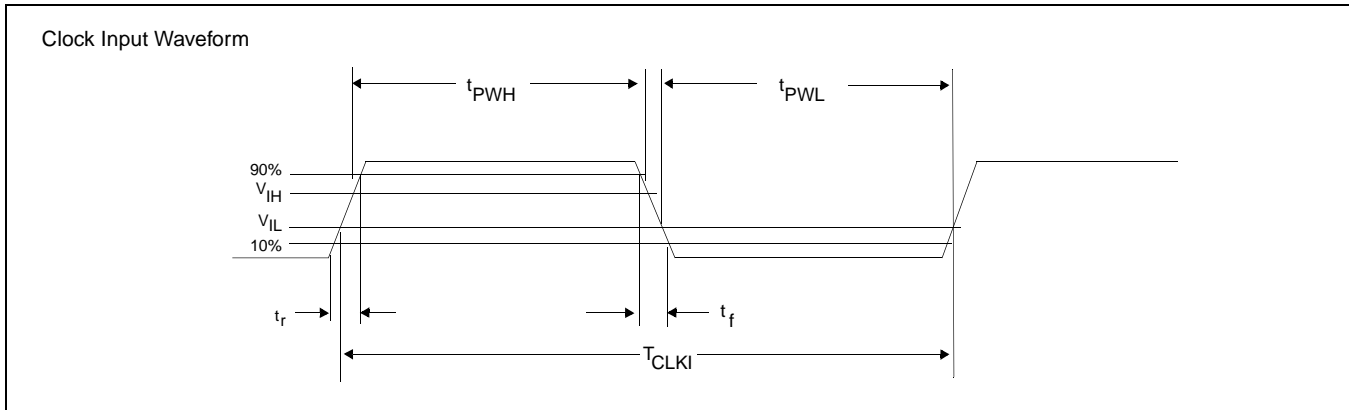

Figure 7-7: Clock Input Requirements for CLKI

Table 7-7: Clock Input Requirements for CLKI

Symbol	Parameter	Min	Max	Units
$f_{CLKI}$	Input Clock Frequency (CLKI)		50	MHz
$T_{CLKI}$	Input Clock period (CLKI)	$1/f_{CLKI}$		ns
$t_{PWH}$	Input Clock Pulse Width High (CLKI)	8		ns
$t_{PWL}$	Input Clock Pulse Width Low (CLKI)	8		ns
$t_f$	Input Clock Fall Time (10% - 90%)		5	ns
$t_r$	Input Clock Rise Time (10% - 90%)		5	ns

### Note

When CLKI is > 25MHz the Input Clock Divide bit (REG[02h] bit 4) must be set to 1.



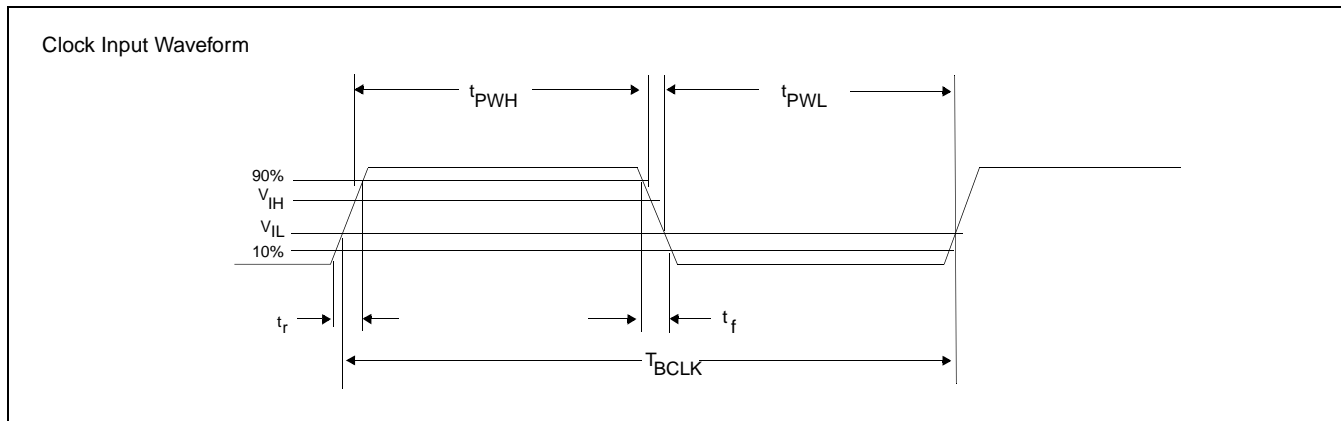

Figure 7-8: Clock Input Requirements for BCLK

Table 7-8: Clock Input Requirements for BCLK

Symbol	Parameter	Min	Max	Units
$f_{BCLK}$	Input Clock Frequency (BCLK)		50	MHz
$T_{BCLK}$	Input Clock period (BCLK)	$1/f_{CLKI}$		
$t_{PWH}$	Input Clock Pulse Width High (BCLK)	8		ns
$t_{PWL}$	Input Clock Pulse Width Low (BCLK)	8		ns
$t_f$	Input Clock Fall Time (10% - 90%)		5	ns
$t_r$	Input Clock Rise Time (10% - 90%)		5	ns

## 7.3 Display Interface

### 7.3.1 Power On/Reset Timing

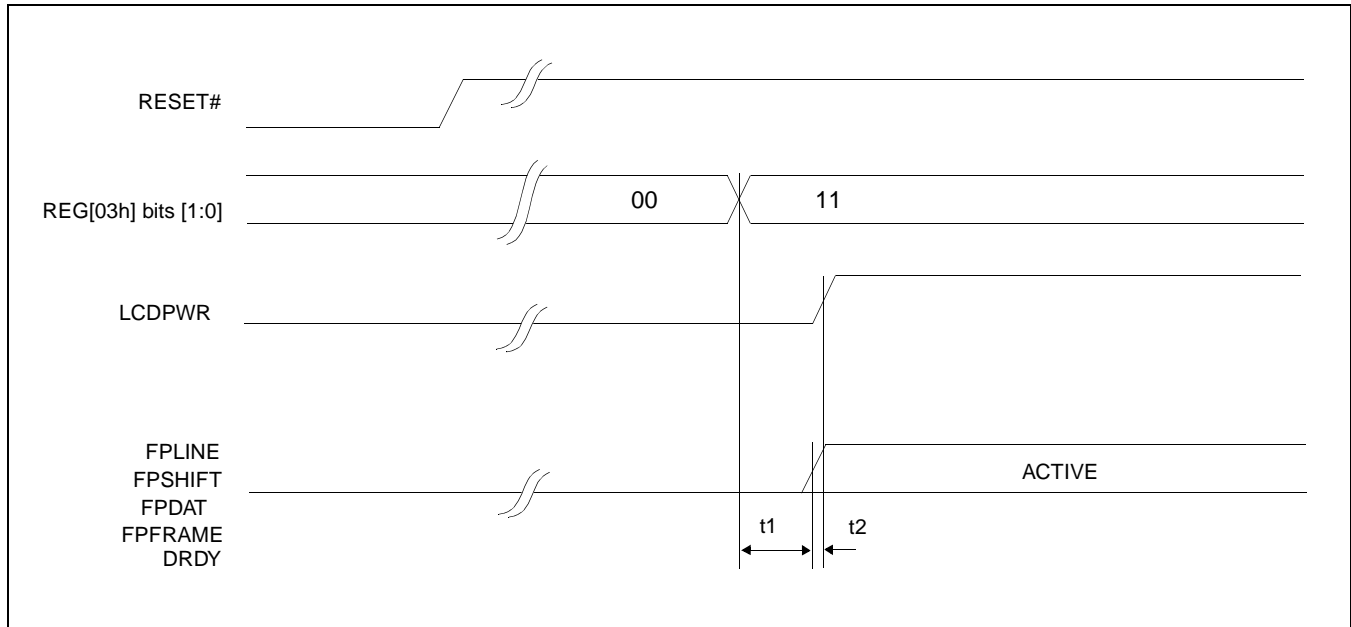

Figure 7-9: LCD Panel Power On/Reset Timing

Table 7-9: LCD Panel Power On/Reset Timing

Symbol	Parameter	Min	Typ	Max	Units
t1	REG[03h] to FPLINE, FPF, FPSHIFT, FPDAT, DRDY active			$T_{FPFRAME}$	ns
t2	FPLINE, FPF, FPSHIFT, FPDAT, DRDY active to LCDPWR		0		Frames

**Note**

Where  $T_{FPFRAME}$  is the period of FPF and  $T_{PCLK}$  is the period of the pixel clock.

### 7.3.2 Power Down/Up Timing

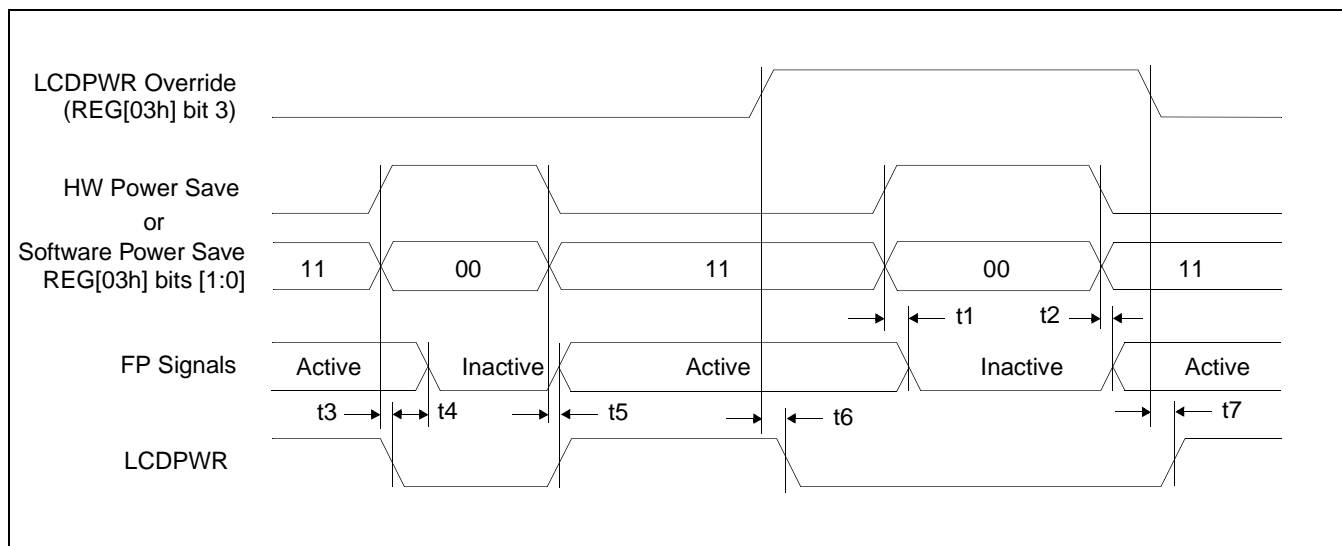

Figure 7-10: Power Down/Up Timing

Table 7-10: Power Down/Up Timing

Symbol	Parameter	Min	Typ	Max	Units
t1	HW Power Save active to FPLINE, FPFRAME, FPSHIFT, FPDAT, DRDY inactive - LCDPWR Override = 1			1	Frame
t2	HW Power Save inactive to FPLINE, FPFRAME, FPSHIFT, FPDAT, DRDY active - LCDPWR Override = 1			1	Frame
t3	HW Power Save active to FPLINE, FPFRAME, FPSHIFT, FPDAT, DRDY inactive - LCDPWR Override = 0			1	Frame
t4	LCDPWR low to FPLINE, FPFRAME, FPSHIFT, FPDAT, DRDY inactive - LCDPWR Override = 0		127		Frame
t5	HW Power Save inactive to FPLINE, FPFRAME, FPSHIFT, FPDAT, DRDY, LCDPWR active - LCDPWR Override = 0		0		Frame
t6	LCDPWR Override active (1) to LCDPWR inactive			1	Frame
t7	LCDPWR Override inactive (1) to LCDPWR active			1	Frame

### 7.3.3 Single Monochrome 4-Bit Panel Timing

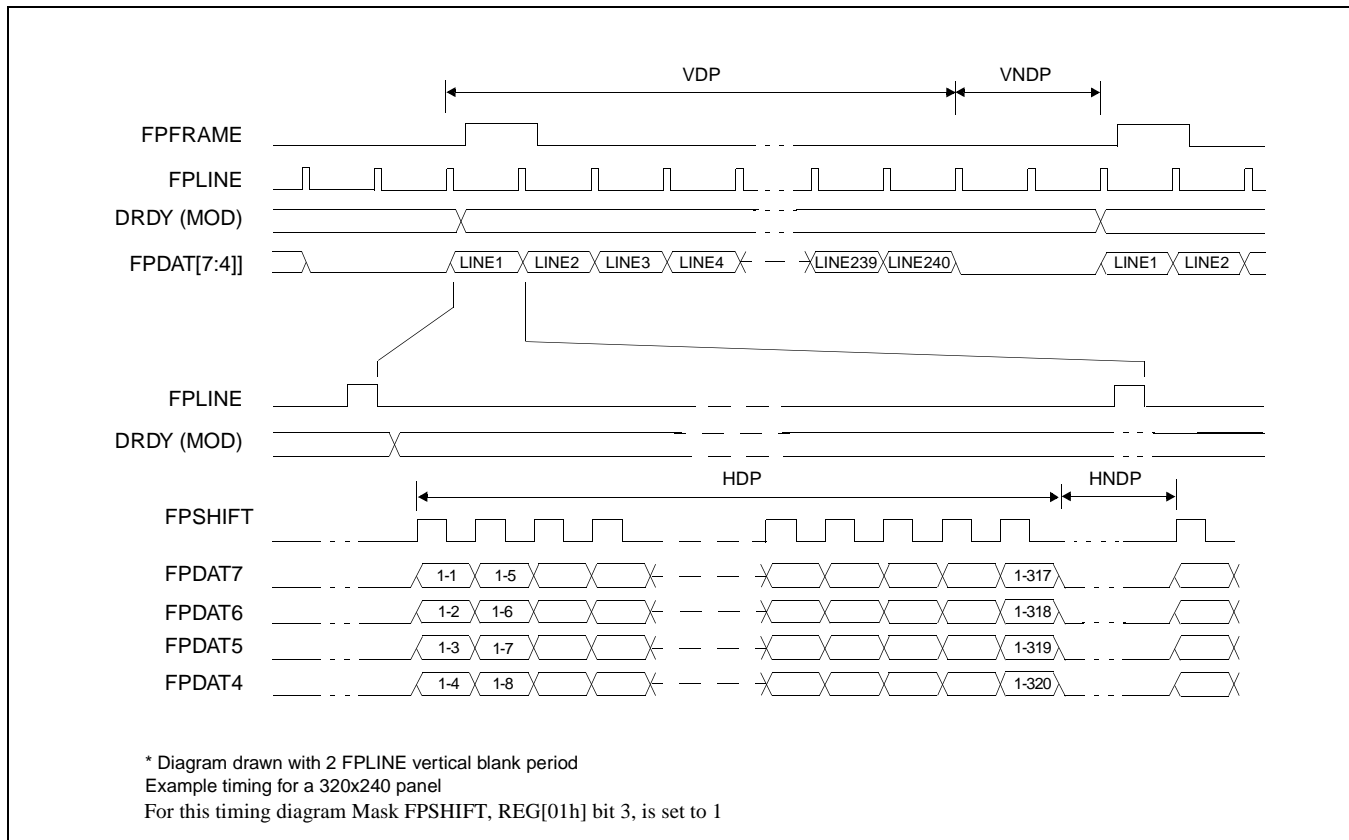

Figure 7-11: Single Monochrome 4-Bit Panel Timing

VDP =	Vertical Display Period	= (REG[06h] bits 1-0, REG[05h] bits 7-0) + 1 Lines
VNDP =	Vertical Non-Display Period	= REG[0Ah] bits 5-0 Lines
HDP =	Horizontal Display Period	= ((REG[04h] bits 6-0) + 1) x 8Ts
HNDP =	Horizontal Non-Display Period	= (REG[08h] + 4) x 8Ts

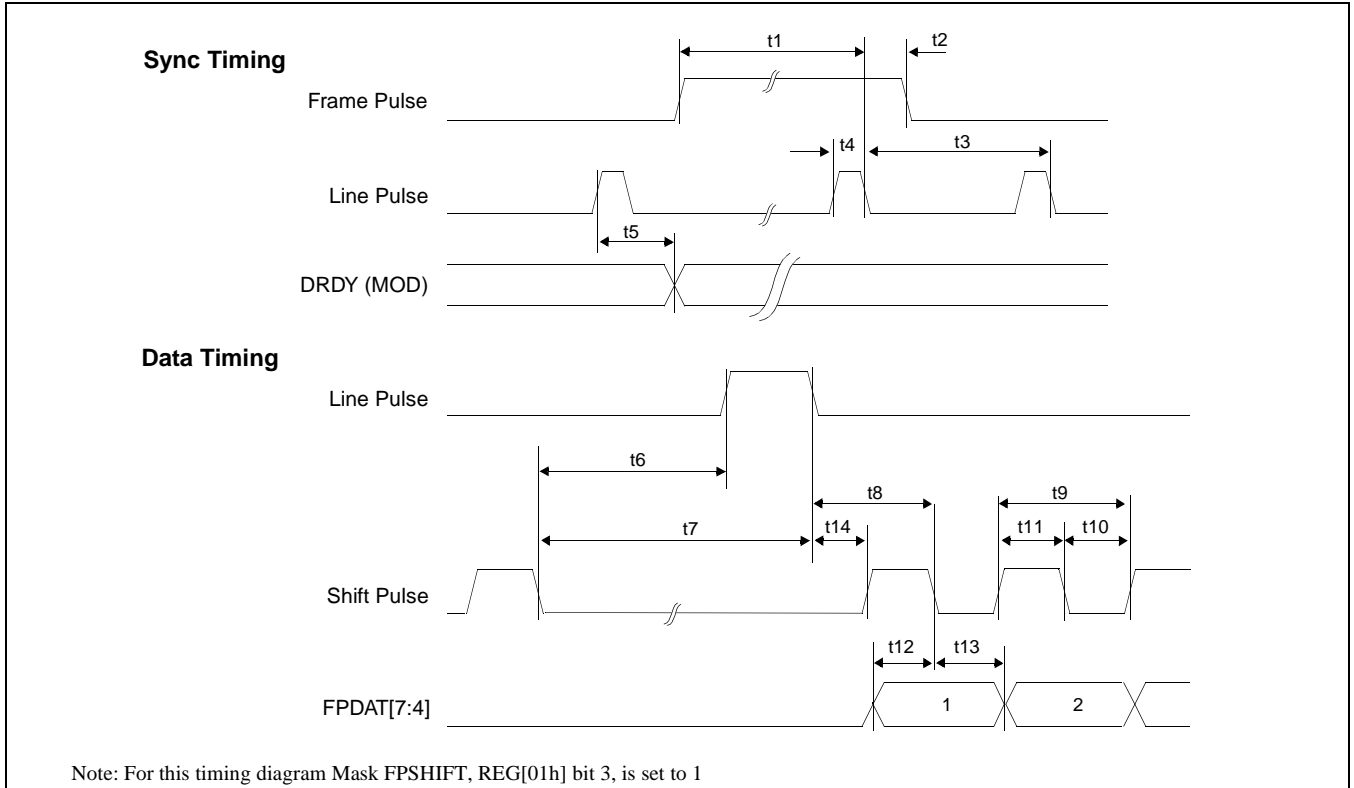

Figure 7-12: Single Monochrome 4-Bit Panel A.C. Timing

Table 7-11: Single Monochrome 4-Bit Panel A.C. Timing

Symbol	Parameter	Min	Typ	Max	Units
t1	Frame Pulse setup to Line Pulse falling edge	note 2			(note 1)
t2	Frame Pulse hold from Line Pulse falling edge	9			Ts
t3	Line Pulse period	note 3			
t4	Line Pulse pulse width	9			Ts
t5	MOD delay from Line Pulse rising edge	1			Ts
t6	Shift Pulse falling edge to Line Pulse rising edge	note 4			
t7	Shift Pulse falling edge to Line Pulse falling edge	note 5			
t8	Line Pulse falling edge to Shift Pulse falling edge	t14 + 2			Ts
t9	Shift Pulse period	4			Ts
t10	Shift Pulse pulse width low	2			Ts
t11	Shift Pulse pulse width high	2			Ts
t12	FPDAT[7:4] setup to Shift Pulse falling edge	2			Ts
t13	FPDAT[7:4] hold to Shift Pulse falling edge	2			Ts
t14	Line Pulse falling edge to Shift Pulse rising edge	23			Ts

1. Ts = pixel clock period
2. t1<sub>min</sub> = t3<sub>min</sub> - 9Ts
3. t3<sub>min</sub> = [((REG[04h] bits 6-0)+1) x 8 + ((REG[08h] bits 4-0) + 4) x 8]Ts
4. t6<sub>min</sub> = [(REG[08h] bits 4-0) x 8 + 2]Ts
5. t7<sub>min</sub> = [(REG[08h] bits 4-0) x 8 + 11]Ts

### 7.3.4 Single Monochrome 8-Bit Panel Timing

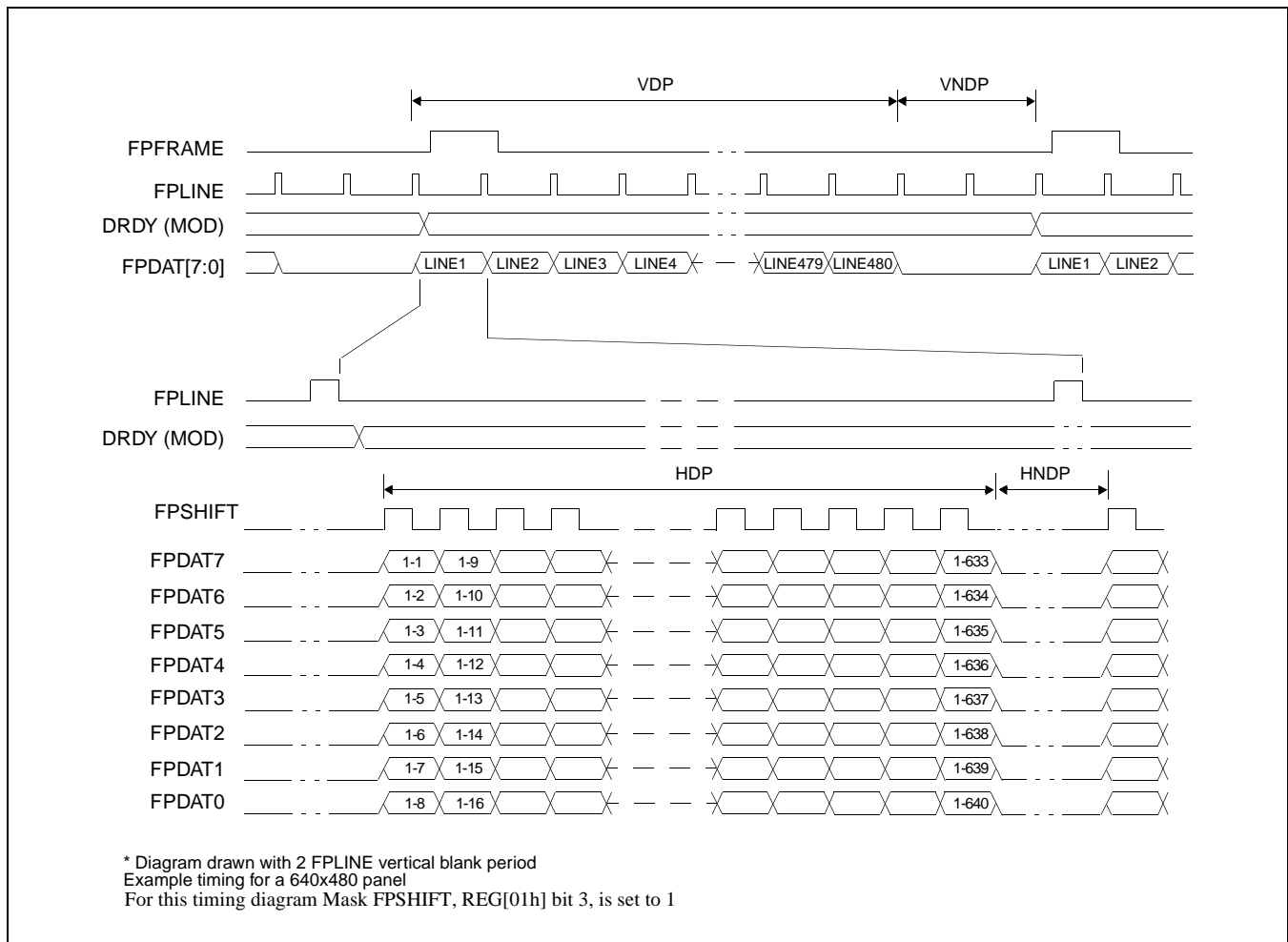

Figure 7-13: Single Monochrome 8-Bit Panel Timing

VDP =	Vertical Display Period	= (REG[06h] bits 1-0, REG[05h] bits 7-0) + 1 Lines
VNDP =	Vertical Non-Display Period	= REG[0Ah] bits 5-0 Lines
HDP =	Horizontal Display Period	= ((REG[04h] bits 6-0) + 1) x 8Ts
HNDP =	Horizontal Non-Display Period	= (REG[08h] + 4) x 8Ts

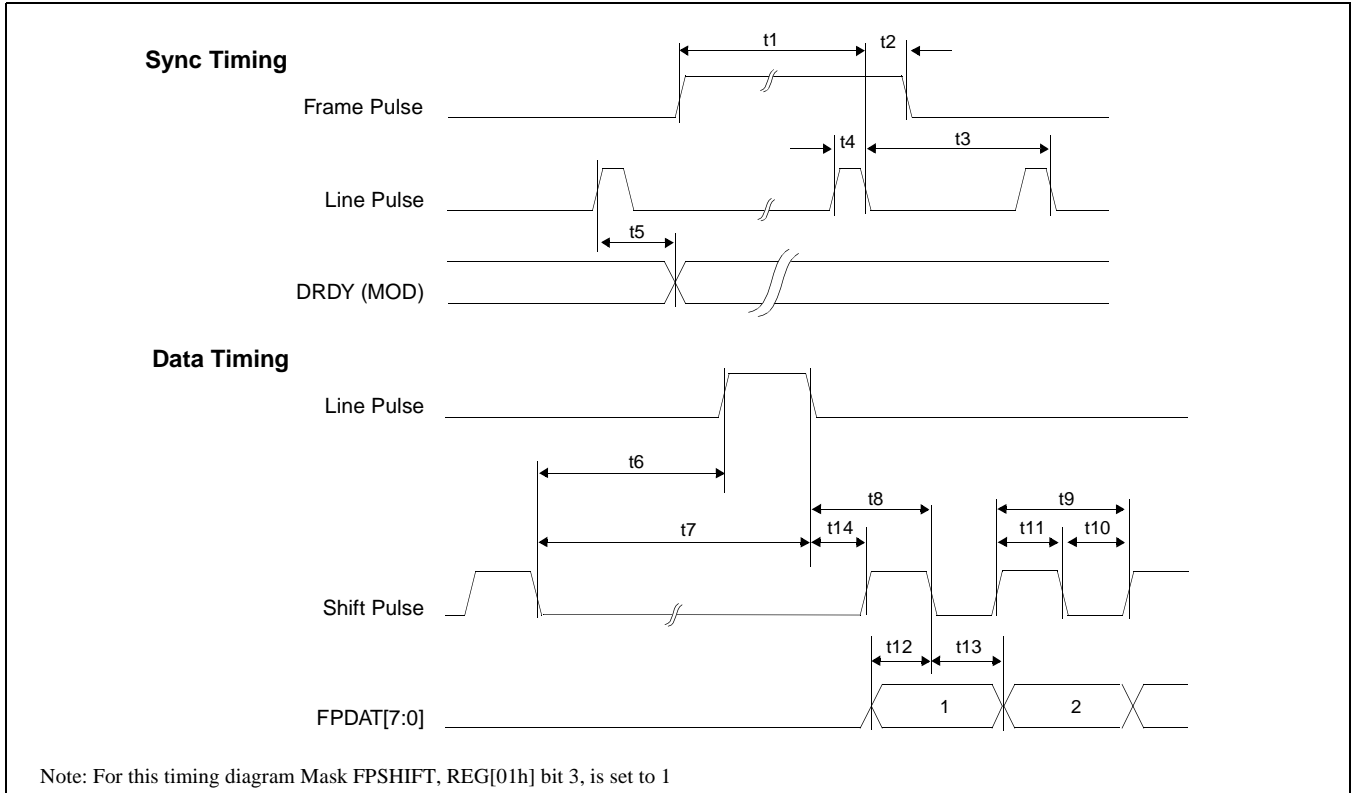

Figure 7-14: Single Monochrome 8-Bit Panel A.C. Timing

Table 7-12: Single Monochrome 8-Bit Panel A.C. Timing

Symbol	Parameter	Min	Typ	Max	Units
t1	Frame Pulse setup to Line Pulse falling edge	note 2			(note 1)
t2	Frame Pulse hold from Line Pulse falling edge	9			Ts
t3	Line Pulse period	note 3			
t4	Line Pulse pulse width	9			Ts
t5	MOD delay from Line Pulse rising edge	1			Ts
t6	Shift Pulse falling edge to Line Pulse rising edge	note 4			
t7	Shift Pulse falling edge to Line Pulse falling edge	note 5			
t8	Line Pulse falling edge to Shift Pulse falling edge	t14 + 4			Ts
t9	Shift Pulse period	8			Ts
t10	Shift Pulse pulse width low	4			Ts
t11	Shift Pulse pulse width high	4			Ts
t12	FPDAT[7:0] setup to Shift Pulse falling edge	4			Ts
t13	FPDAT[7:0] hold to Shift Pulse falling edge	4			Ts
t14	Line Pulse falling edge to Shift Pulse rising edge	23			Ts

1. Ts = pixel clock period
2. t1<sub>min</sub> = t3<sub>min</sub> - 9Ts
3. t3<sub>min</sub> = [((REG[04h] bits 6-0)+1) x 8 + ((REG[08h] bits 4-0) + 4) x 8]Ts
4. t6<sub>min</sub> = [(REG[08h] bits 4-0) x 8 + 4]Ts
5. t7<sub>min</sub> = [(REG[08h] bits 4-0) x 8 + 13]Ts

### 7.3.5 Single Color 4-Bit Panel Timing

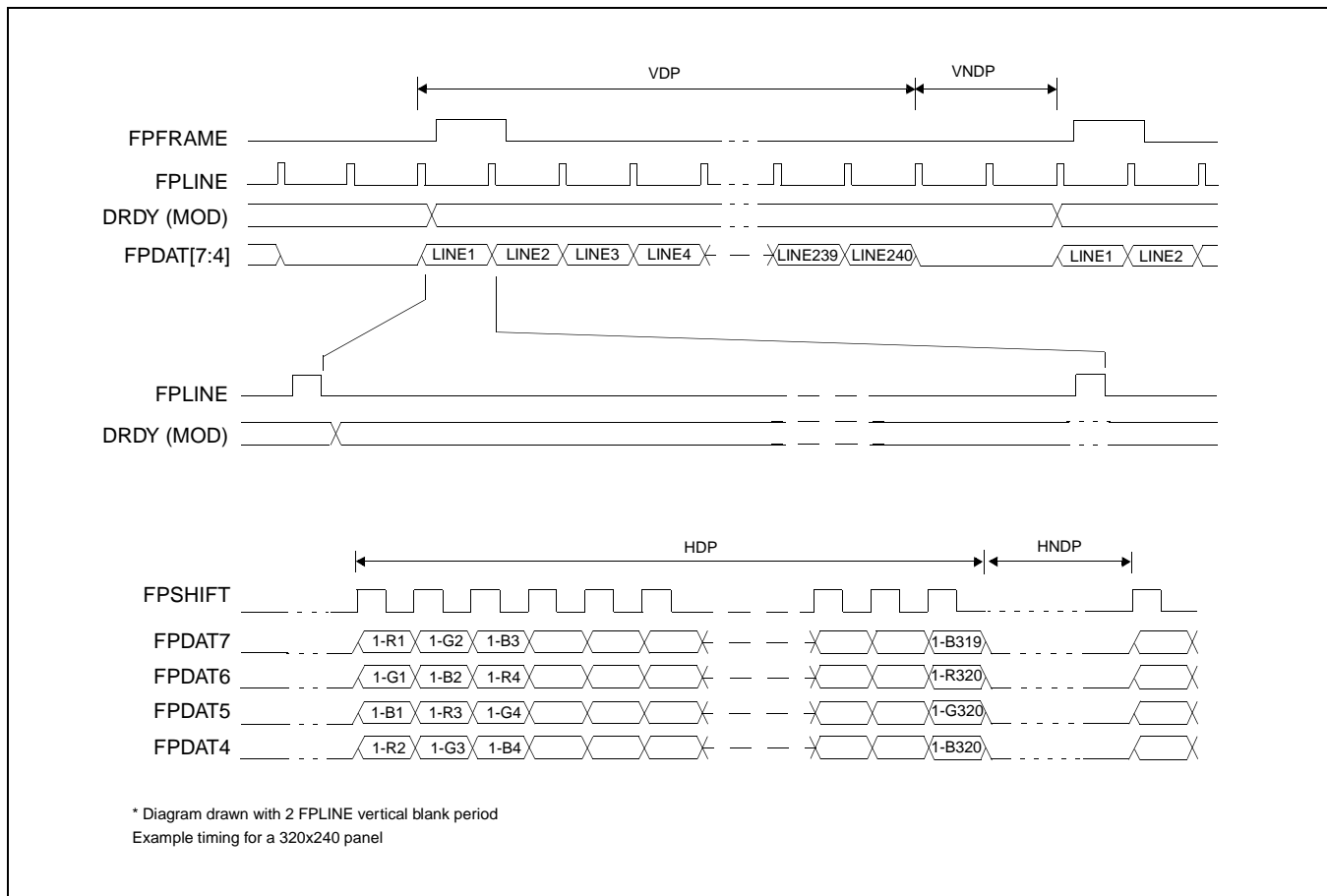

Figure 7-15: Single Color 4-Bit Panel Timing

VDP =	Vertical Display Period	= (REG[06h] bits 1-0, REG[05h] bits 7-0) + 1 Lines
VNDP =	Vertical Non-Display Period	= REG[0Ah] bits 5-0 Lines
HDP =	Horizontal Display Period	= ((REG[04h] bits 6-0) + 1) x 8Ts
HNDP =	Horizontal Non-Display Period	= (REG[08h] + 4) x 8Ts



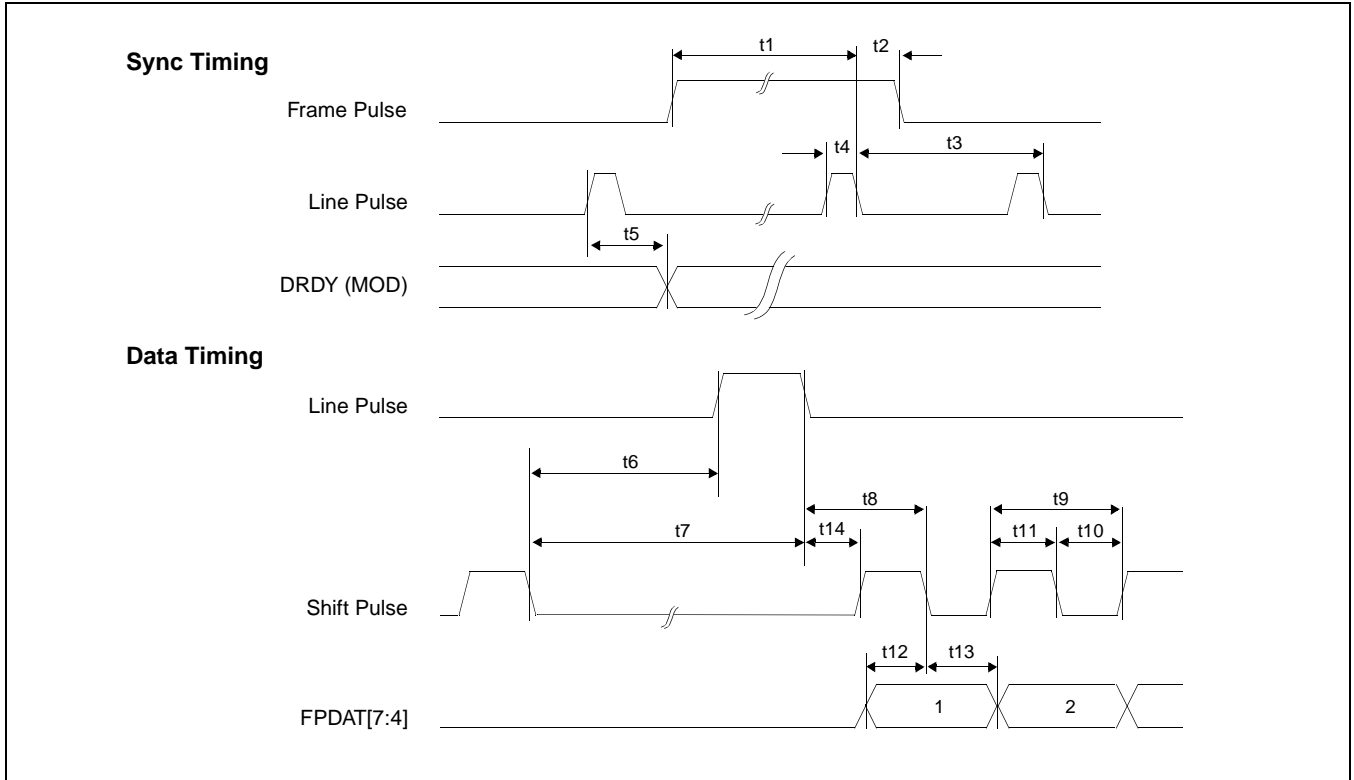

Figure 7-16: Single Color 4-Bit Panel A.C. Timing

Table 7-13: Single Color 4-Bit Panel A.C. Timing

Symbol	Parameter	Min	Typ	Max	Units
t1	Frame Pulse setup to Line Pulse falling edge	note 2			(note 1)
t2	Frame Pulse hold from Line Pulse falling edge	9			Ts
t3	Line Pulse period	note 3			
t4	Line Pulse pulse width	9			Ts
t5	MOD delay from Line Pulse rising edge	1			Ts
t6	Shift Pulse falling edge to Line Pulse rising edge	note 4			
t7	Shift Pulse falling edge to Line Pulse falling edge	note 5			
t8	Line Pulse falling edge to Shift Pulse falling edge	t14 + 0.5			Ts
t9	Shift Pulse period	1			Ts
t10	Shift Pulse pulse width low	0.5			Ts
t11	Shift Pulse pulse width high	0.5			Ts
t12	FPDAT[7:4] setup to Shift Pulse falling edge	0.5			Ts
t13	FPDAT[7:4] hold to Shift Pulse falling edge	0.5			Ts
t14	Line Pulse falling edge to Shift Pulse rising edge	24			Ts

1. Ts = pixel clock period
2. t1<sub>min</sub> = t3<sub>min</sub> - 9Ts
3. t3<sub>min</sub> = [((REG[04h] bits 6-0)+1) x 8 + ((REG[08h] bits 4-0) + 4) x 8]Ts
4. t6<sub>min</sub> = [(REG[08h] bits 4-0) x 8 + 1.5]Ts
5. t7<sub>min</sub> = [(REG[08h] bits 4-0) x 8 + 10]Ts

### 7.3.6 Single Color 8-Bit Panel Timing (Format 1)

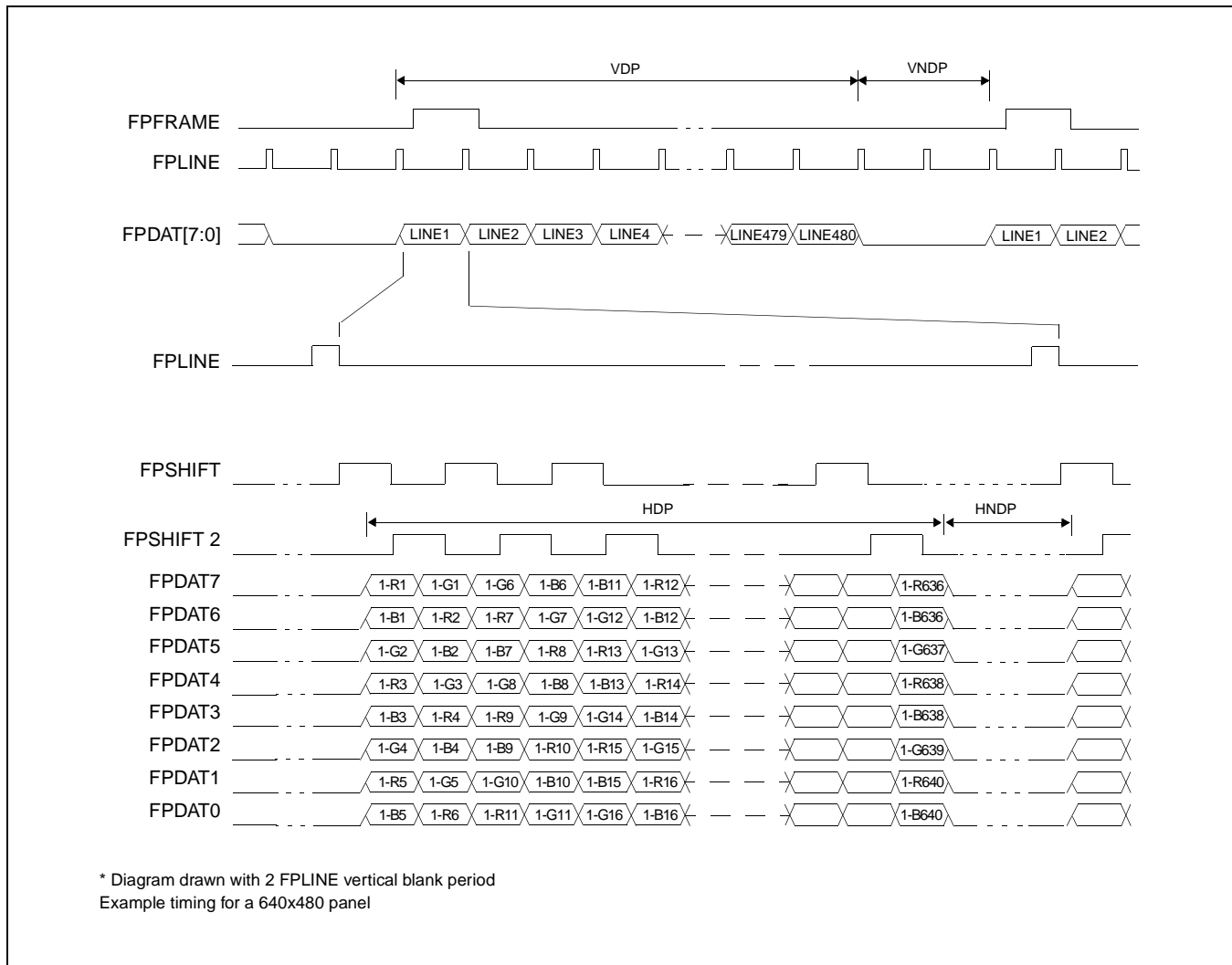

Figure 7-17: Single Color 8-Bit Panel Timing (Format 1)

VDP =	Vertical Display Period	= (REG[06h] bits 1-0, REG[05h] bits 7-0) + 1 Lines
VNDP =	Vertical Non-Display Period	= REG[0Ah] bits 5-0 Lines
HDP =	Horizontal Display Period	= ((REG[04h] bits 6-0) + 1) x 8Ts
HNDP =	Horizontal Non-Display Period	= (REG[08h] + 4) x 8Ts

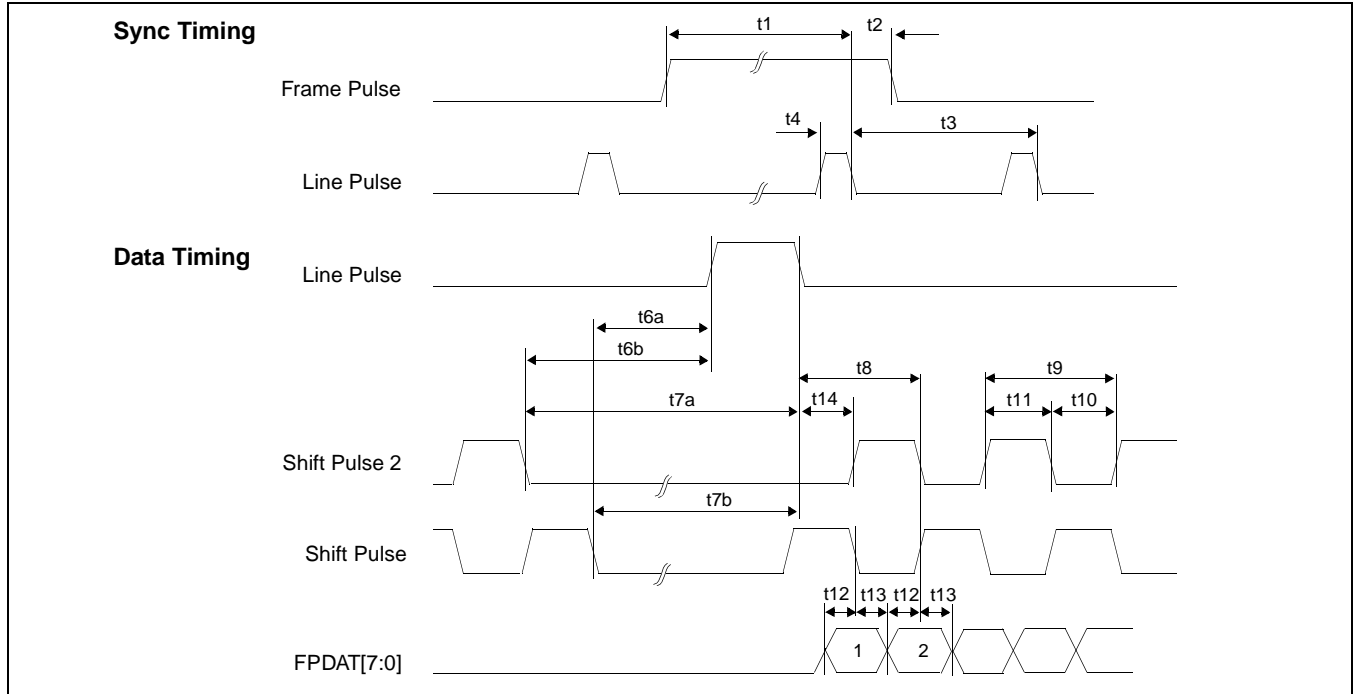

Figure 7-18: Single Color 8-Bit Panel A.C. Timing (Format 1)

Table 7-14: Single Color 8-Bit Panel A.C. Timing (Format 1)

Symbol	Parameter	Min	Typ	Max	Units
t1	Frame Pulse setup to Line Pulse falling edge	note 2			(note 1)
t2	Frame Pulse hold from Line Pulse falling edge	9			Ts
t3	Line Pulse period	note 3			
t4	Line Pulse pulse width	9			Ts
t6a	Shift Pulse falling edge to Line Pulse rising edge	note 4			
t6b	Shift Pulse 2 falling edge to Line Pulse rising edge	note 5			
t7a	Shift Pulse 2 falling edge to Line Pulse falling edge	note 6			
t7b	Shift Pulse falling edge to Line Pulse falling edge	note 7			
t8	Line Pulse falling edge to Shift Pulse rising, Shift Pulse 2 falling edge	t14 + 2			Ts
t9	Shift Pulse 2, Shift Pulse period	4			Ts
t10	Shift Pulse 2, Shift Pulse pulse width low	2			Ts
t11	Shift Pulse 2, Shift Pulse pulse width high	2			Ts
t12	FPDAT[7:0] setup to Shift Pulse 2, Shift Pulse falling edge	1			Ts
t13	FPDAT[7:0] hold from Shift Pulse 2, Shift Pulse falling edge	1			Ts
t14	Line Pulse falling edge to Shift Pulse rising edge	25			Ts

1. Ts = pixel clock period
2. t1<sub>min</sub> = t3<sub>min</sub> - 9Ts
3. t3<sub>min</sub> = [((REG[04h] bits 6-0)+1) x 8 + ((REG[08h] bits 4-0) + 4) x 8]Ts
4. t6a<sub>min</sub> = [(REG[08h] bits 4-0) x 8]Ts
5. t6b<sub>min</sub> = [(REG[08h] bits 4-0) x 8 + 2]Ts
6. t7a<sub>min</sub> = [(REG[08h] bits 4-0) x 8 + 11]Ts
7. t7b<sub>min</sub> = [(REG[08h] bits 4-0) x 8 + 11] - t10]Ts

### 7.3.7 Single Color 8-Bit Panel Timing (Format 2)

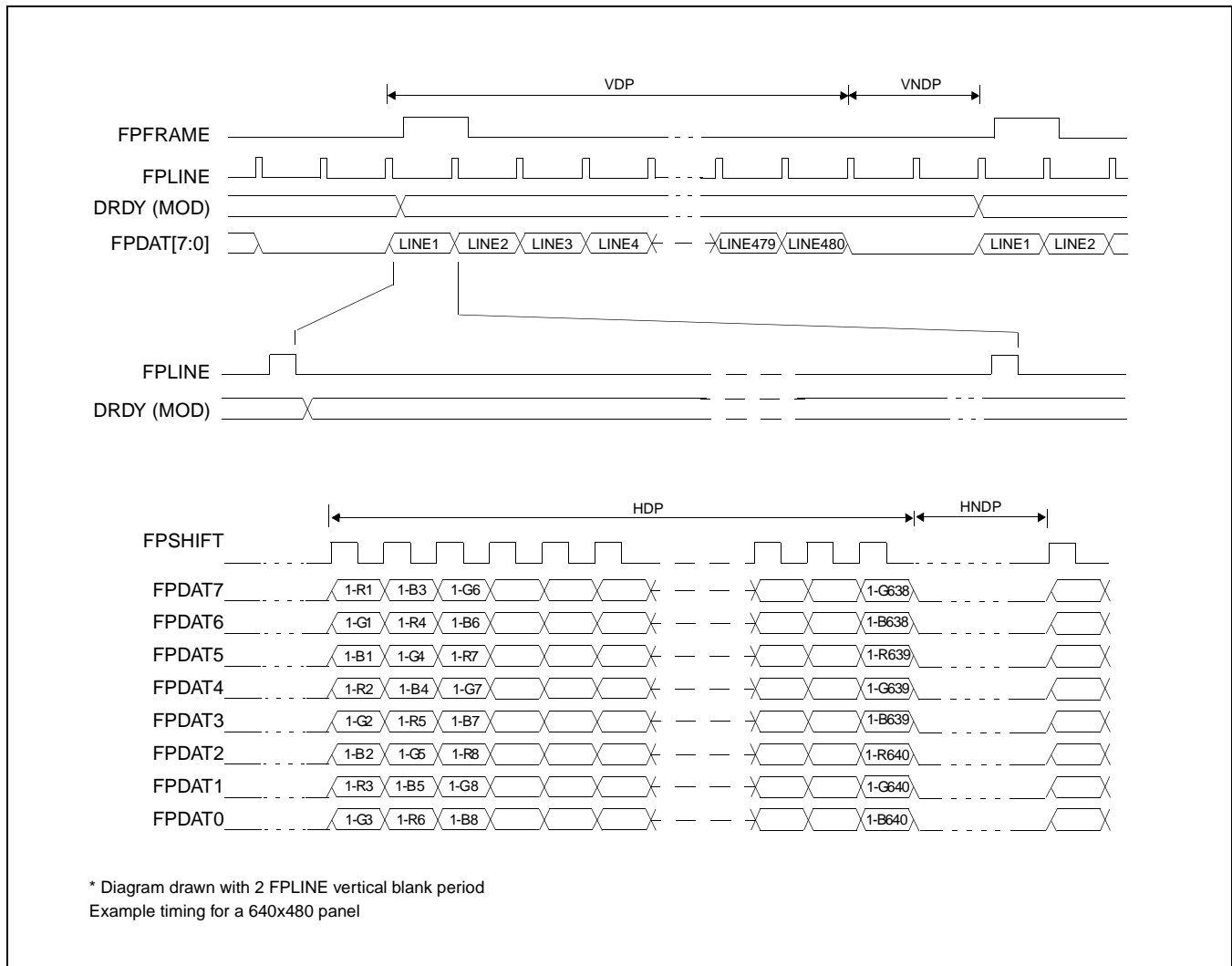

Figure 7-19: Single Color 8-Bit Panel Timing (Format 2)

VDP =	Vertical Display Period	= (REG[06h] bits 1-0, REG[05h] bits 7-0) + 1 Lines
VNDP =	Vertical Non-Display Period	= REG[0Ah] bits 5-0 Lines
HDP =	Horizontal Display Period	= ((REG[04h] bits 6-0) + 1) x 8Ts
HNDP =	Horizontal Non-Display Period	= (REG[08h] + 4) x 8Ts

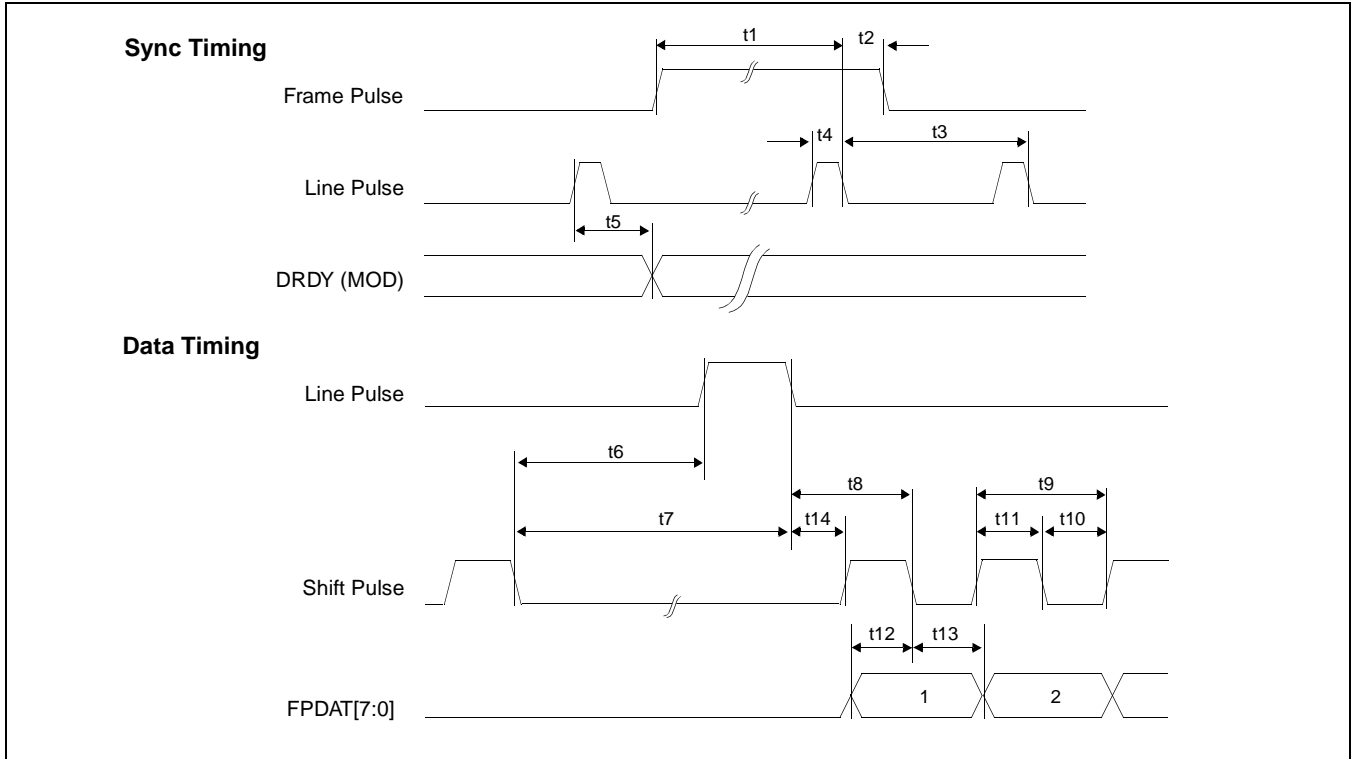

Figure 7-20: Single Color 8-Bit Panel A.C. Timing (Format 2)

Table 7-15: Single Color 8-Bit Panel A.C. Timing (Format 2)

Symbol	Parameter	Min	Typ	Max	Units
t1	Frame Pulse setup to Line Pulse falling edge	note 2			(note 1)
t2	Frame Pulse hold from Line Pulse falling edge	9			Ts
t3	Line Pulse period	note 3			
t4	Line Pulse pulse width	9			Ts
t5	MOD delay from Line Pulse rising edge	1			Ts
t6	Shift Pulse falling edge to Line Pulse rising edge	note 4			
t7	Shift Pulse falling edge to Line Pulse falling edge	note 5			
t8	Line Pulse falling edge to Shift Pulse falling edge	t14 + 2			Ts
t9	Shift Pulse period	2			Ts
t10	Shift Pulse pulse width low	1			Ts
t11	Shift Pulse pulse width high	1			Ts
t12	FPDAT[7:0] setup to Shift Pulse falling edge	1			Ts
t13	FPDAT[7:0] hold to Shift Pulse falling edge	1			Ts
t14	Line Pulse falling edge to Shift Pulse rising edge	23			Ts

1. Ts = pixel clock period
2.  $t_{1\min}$  =  $t_{3\min} - 9Ts$
3.  $t_{3\min}$  =  $[(REG[04h] \text{ bits } 6-0)+1] \times 8 + [(REG[08h] \text{ bits } 4-0) + 4] \times 8Ts$
4.  $t_{6\min}$  =  $[(REG[08h] \text{ bits } 4-0) \times 8 + 1]Ts$
5.  $t_{7\min}$  =  $[(REG[08h] \text{ bits } 4-0) \times 8 + 10]Ts$

### 7.3.8 Dual Monochrome 8-Bit Panel Timing

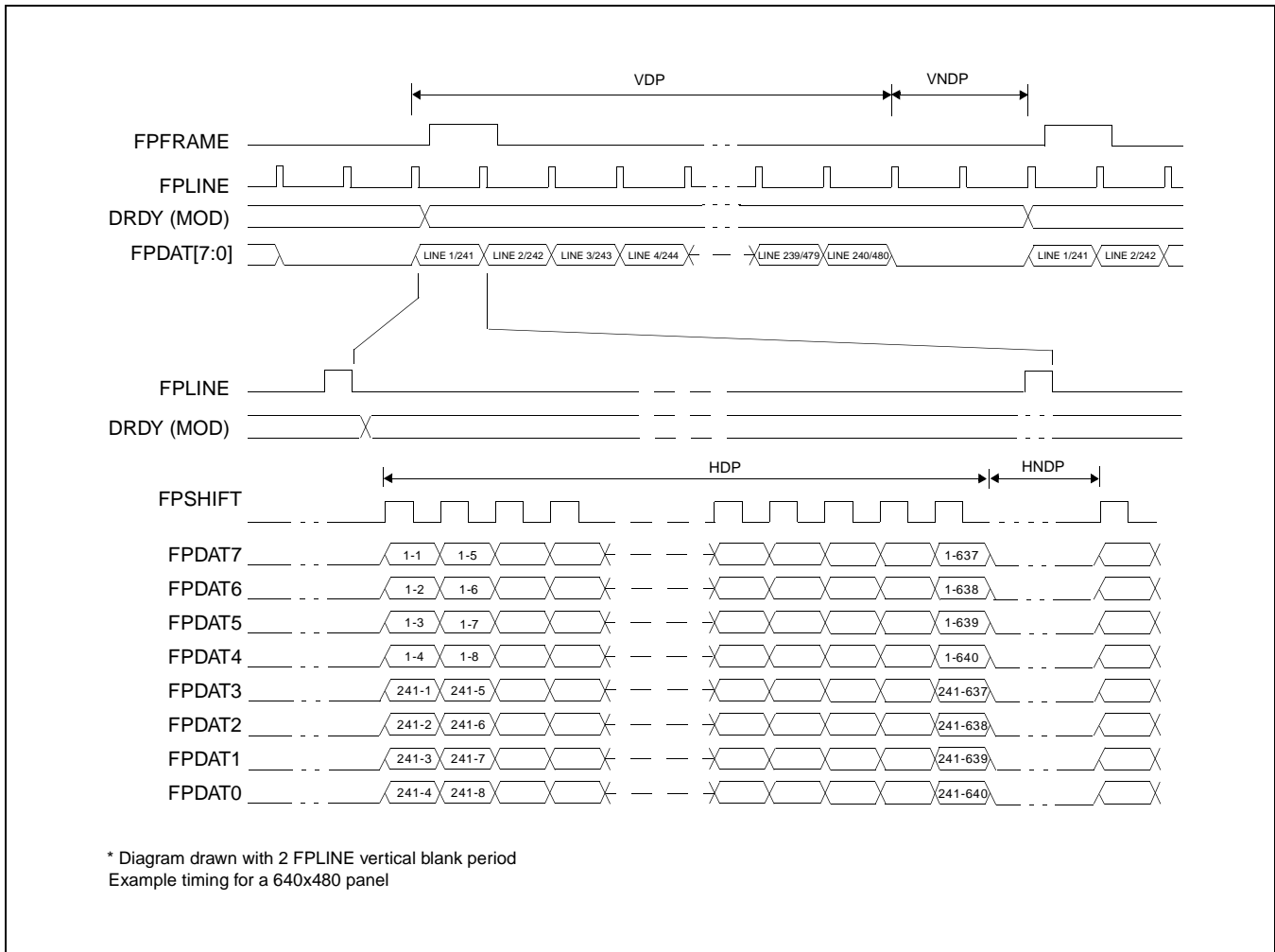

Figure 7-21: Dual Monochrome 8-Bit Panel Timing

VDP =	Vertical Display Period	= (REG[06h] bits 1-0, REG[05h] bits 7-0) + 1 Lines
VNDP =	Vertical Non-Display Period	= REG[0Ah] bits 5-0 Lines
HDP =	Horizontal Display Period	= ((REG[04h] bits 6-0) + 1) x 8Ts
HNDP =	Horizontal Non-Display Period	= (REG[08h] + 4) x 8Ts

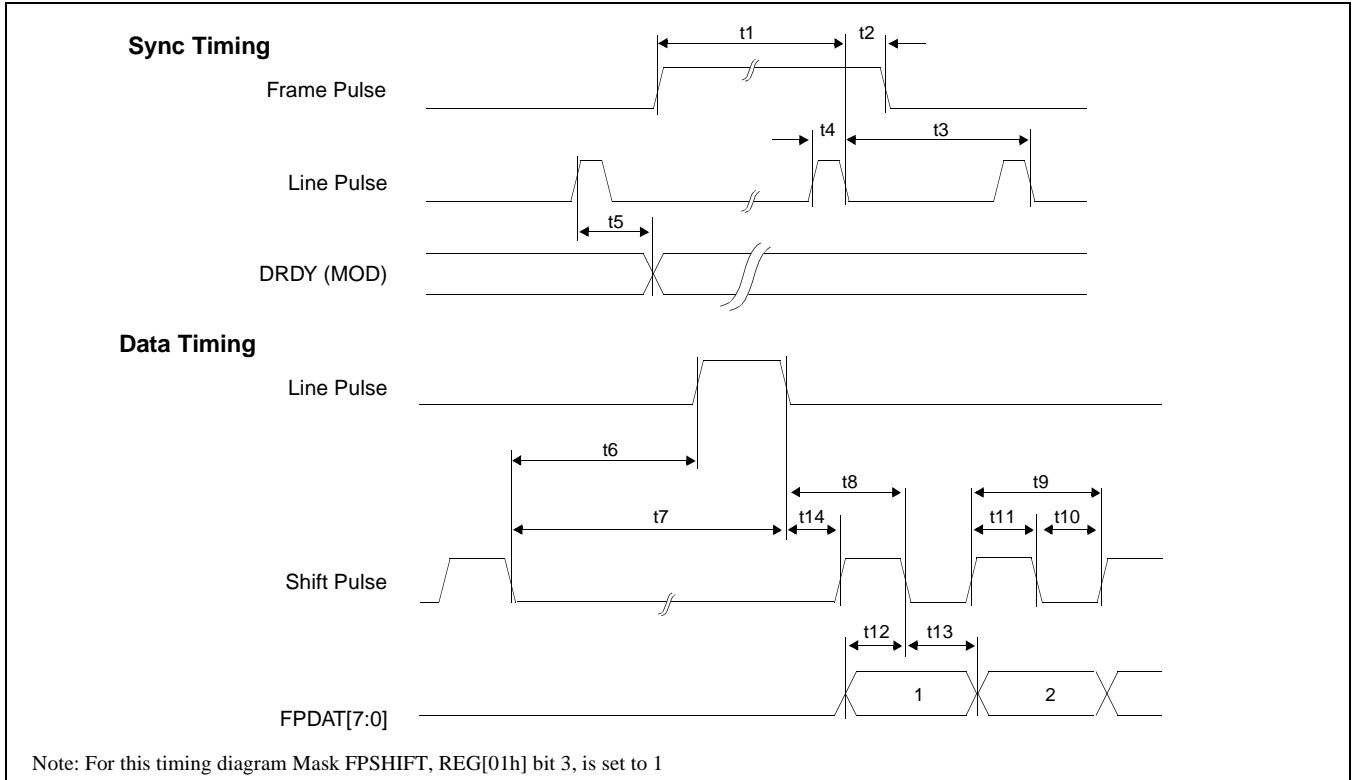

Figure 7-22: Dual Monochrome 8-Bit Panel A.C. Timing

Table 7-16: Dual Monochrome 8-Bit Panel A.C. Timing

Symbol	Parameter	Min	Typ	Max	Units
t1	Frame Pulse setup to Line Pulse falling edge	note 2			(note 1)
t2	Frame Pulse hold from Line Pulse falling edge	9			Ts
t3	Line Pulse period	note 3			
t4	Line Pulse pulse width	9			Ts
t5	MOD delay from Line Pulse falling edge	1			Ts
t6	Shift Pulse falling edge to Line Pulse rising edge	note 5			
t7	Shift Pulse falling edge to Line Pulse falling edge	note 6			
t8	Line Pulse falling edge to Shift Pulse falling edge	t14 + 2			Ts
t9	Shift Pulse period	8			Ts
t10	Shift Pulse pulse width low	4			Ts
t11	Shift Pulse pulse width high	4			Ts
t12	FPDAT[7:0] setup to Shift Pulse falling edge	4			Ts
t13	FPDAT[7:0] hold to Shift Pulse falling edge	4			Ts
t14	Line Pulse falling edge to Shift Pulse rising edge	39			Ts

1. Ts = pixel clock period
2. t1<sub>min</sub> = t3<sub>min</sub> - 9Ts
3. t3<sub>min</sub> = [(((REG[04h] bits 6-0)+1) x 8 + ((REG[08h] bits 4-0) + 4) x 8) x 2]Ts
5. t6<sub>min</sub> = [((REG[08h] bits 4-0) x 2) x 8 + 20]Ts
6. t7<sub>min</sub> = [((REG[08h] bits 4-0) x 2) x 8 + 29]Ts

### 7.3.9 Dual Color 8-Bit Panel Timing

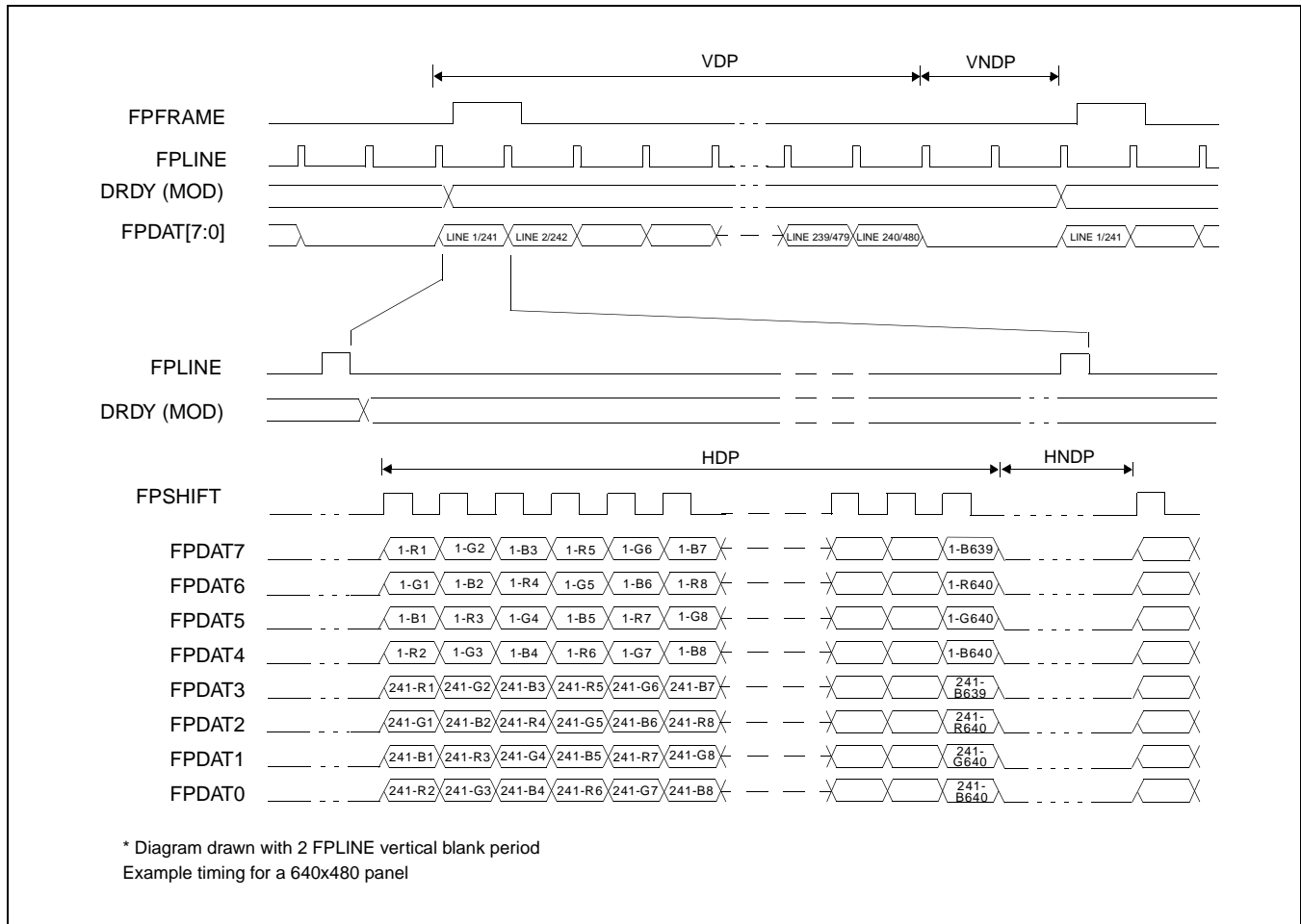

Figure 7-23: Dual Color 8-Bit Panel Timing

VDP =	Vertical Display Period	= (REG[06h] bits 1-0, REG[05h] bits 7-0) + 1 Lines
VNDP =	Vertical Non-Display Period	= REG[0Ah] bits 5-0 Lines
HDP =	Horizontal Display Period	= ((REG[04h] bits 6-0) + 1) x 8Ts
HNDP =	Horizontal Non-Display Period	= (REG[08h] + 4) x 8Ts



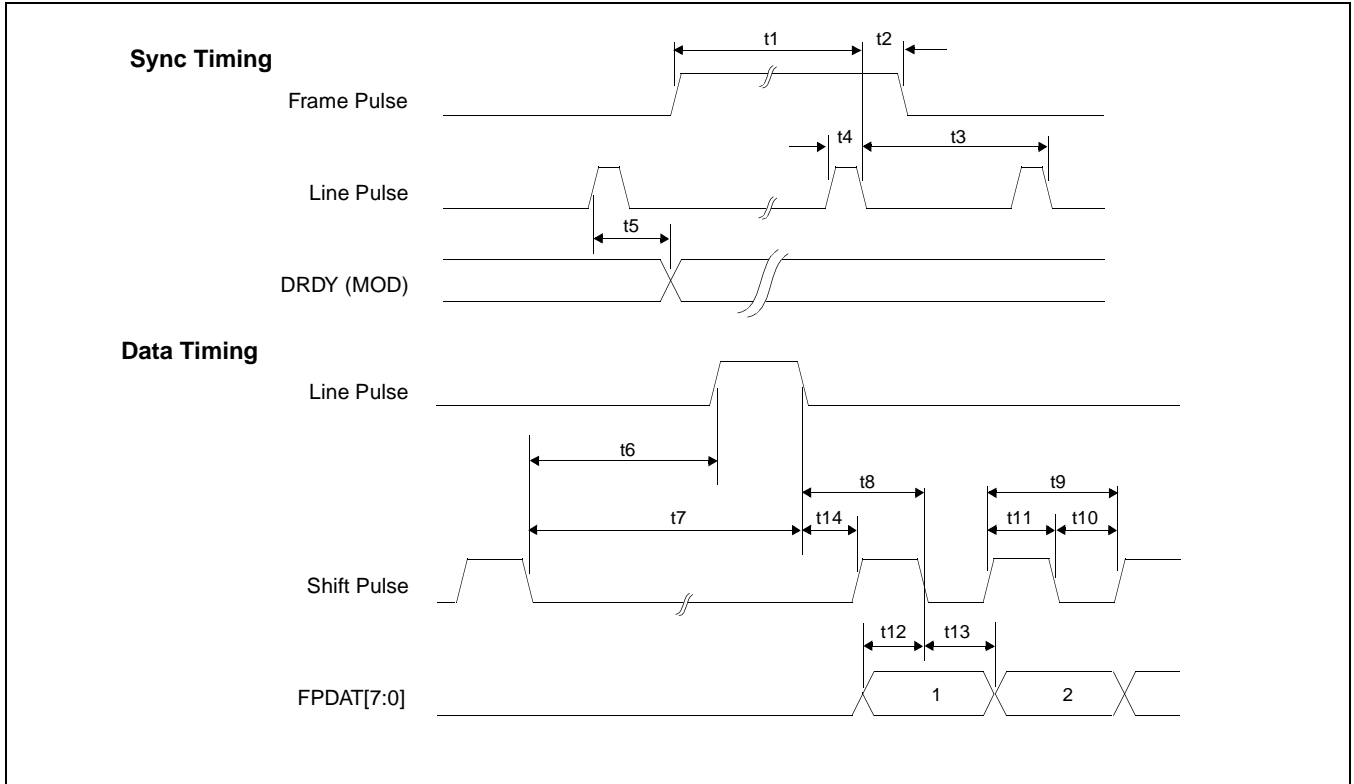

Figure 7-24: Dual Color 8-Bit Panel A.C. Timing

Table 7-17: Dual Color 8-Bit Panel A.C. Timing

Symbol	Parameter	Min	Typ	Max	Units
t1	Frame Pulse setup to Line Pulse falling edge	note 2			(note 1)
t2	Frame Pulse hold from Line Pulse falling edge	9			Ts
t3	Line Pulse period	note 3			
t4	Line Pulse pulse width	9			Ts
t5	MOD delay from Line Pulse falling edge	1			Ts
t6	Shift Pulse falling edge to Line Pulse rising edge	note 5			
t7	Shift Pulse falling edge to Line Pulse falling edge	note 6			
t8	Line Pulse falling edge to Shift Pulse falling edge	t14 + 1			Ts
t9	Shift Pulse period	2			Ts
t10	Shift Pulse pulse width low	1			Ts
t11	Shift Pulse pulse width high	1			Ts
t12	FPDAT[7:0] setup to Shift Pulse falling edge	1			Ts
t13	FPDAT[7:0] hold to Shift Pulse falling edge	1			Ts
t14	Line Pulse falling edge to Shift Pulse rising edge	39			Ts

1. Ts = pixel clock period
2.  $t_{1\min} = t_{3\min} - 9Ts$
3.  $t_{3\min} = [(((REG[04h] \text{ bits } 6-0) + 1) \times 8 + ((REG[08h] \text{ bits } 4-0) + 4) \times 8) \times 2]Ts$
5.  $t_{6\min} = [((REG[08h] \text{ bits } 4-0) \times 2) \times 8 + 17]Ts$
6.  $t_{7\min} = [((REG[08h] \text{ bits } 4-0) \times 2) \times 8 + 26]Ts$

### 7.3.10 9/12-Bit TFT/D-TFD Panel Timing

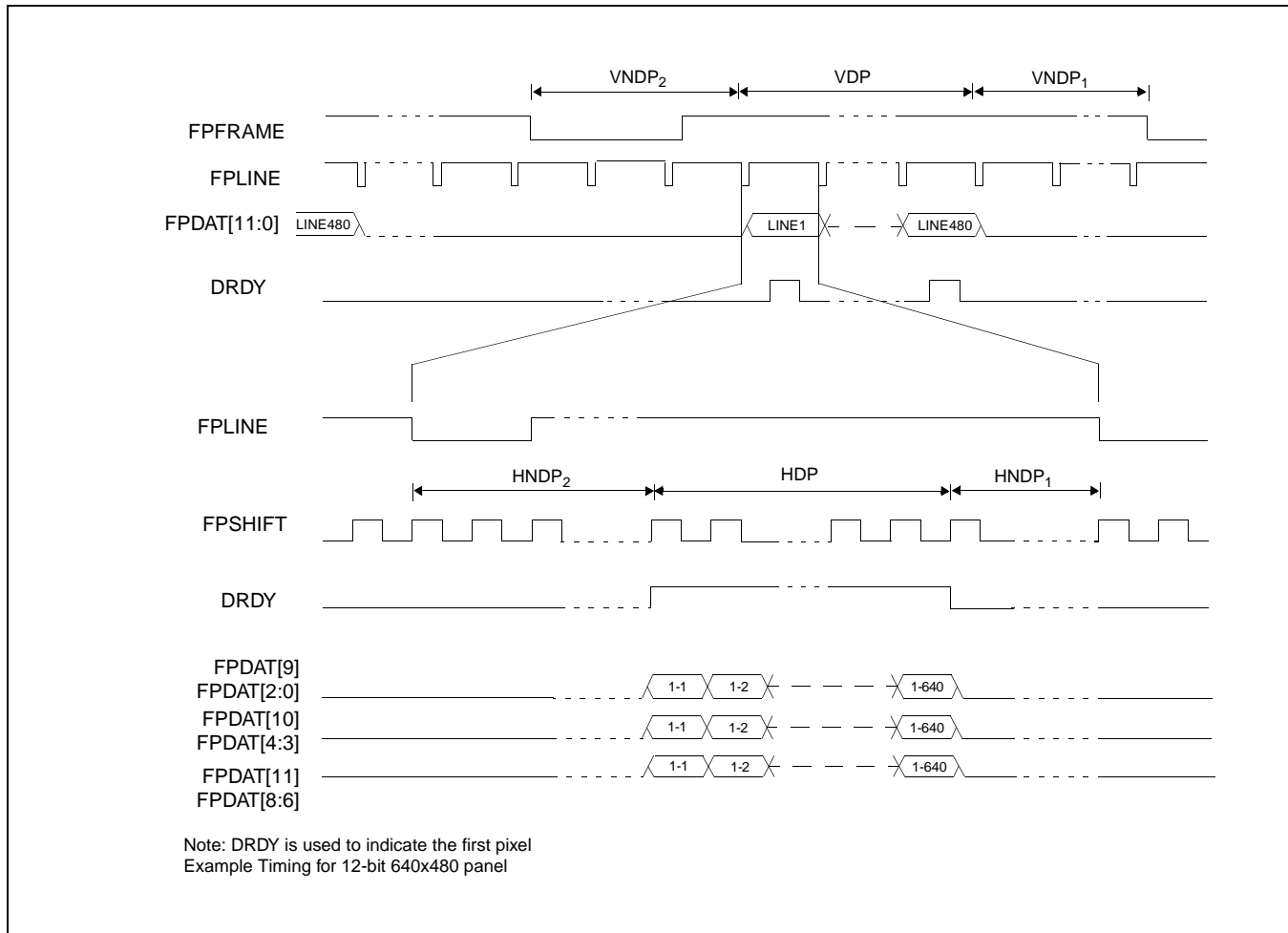

Figure 7-25: 12-Bit TFT/D-TFD Panel Timing

VDP =	Vertical Display Period	= (REG[06h] bits 1-0, REG[05h] bits 7-0) + 1 Lines
VNDP =	Vertical Non-Display Period	= VNDP1 + VNDP2 = (REG[0Ah] bits 5-0) Lines
VNDP1 =	Vertical Non-Display Period 1	= REG[09h] bits 5-0 Lines
VNDP2 =	Vertical Non-Display Period 2	= (REG[0Ah] bits 5-0) - (REG[09Ah] bits 5-0) Lines
HDP =	Horizontal Display Period	= ((REG[04h] bits 6-0) + 1) x 8Ts
HNDP =	Horizontal Non-Display Period	= HNDP1 + HNDP2 = (REG[08h] + 4) x 8Ts
HNDP1 =	Horizontal Non-Display Period 1	= (((REG[07h] bits 4-0) x 8) + 16)Ts
HNDP2 =	Horizontal Non-Display Period 2	= (((REG[08h] bits 4-0) - (REG[07h] bits 4-0)) x 8) + 16Ts

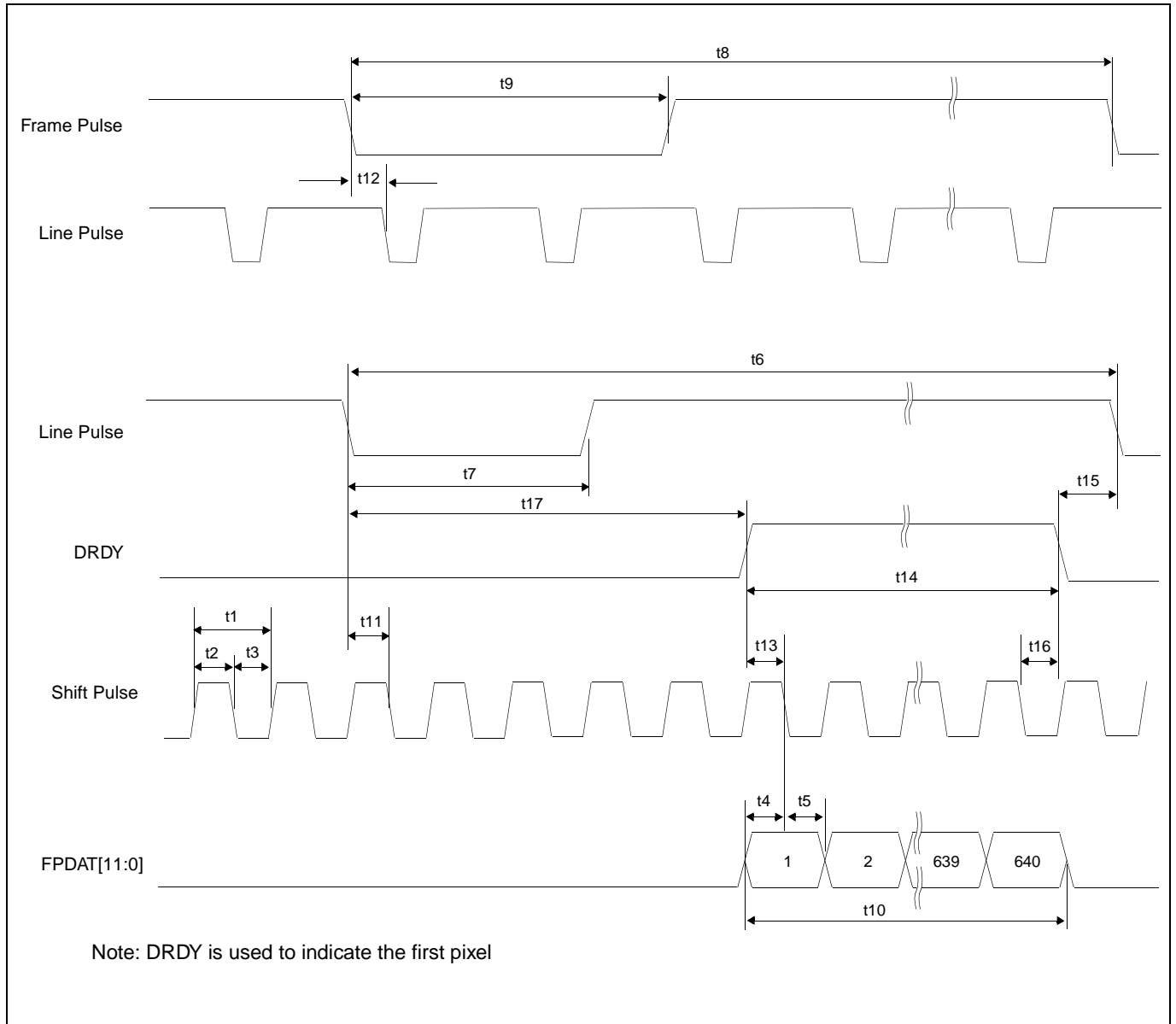

Figure 7-26: TFT/D-TFD A.C. Timing

Table 7-18: TFT/D-TFD A.C. Timing

Symbol	Parameter	Min	Typ	Max	Units
t1	Shift Pulse period	1			(note 1)
t2	Shift Pulse pulse width high	0.5			Ts
t3	Shift Pulse pulse width low	0.5			Ts
t4	data setup to Shift Pulse falling edge	0.5			Ts
t5	data hold from Shift Pulse falling edge	0.5			Ts
t6	Line Pulse cycle time	note 2			
t7	Line Pulse pulse width low	9			Ts
t8	Frame Pulse cycle time	note 3			
t9	Frame Pulse pulse width low	2t6			
t10	horizontal display period	note 4			
t11	Line Pulse setup to Shift Pulse falling edge	0.5			Ts
t12	Frame Pulse falling edge to Line Pulse falling edge phase difference	t6 - 18Ts			
t13	DRDY to Shift Pulse falling edge setup time	0.5			Ts
t14	DRDY pulse width	note 5			
t15	DRDY falling edge to Line Pulse falling edge	note 6			
t16	DRDY hold from Shift Pulse falling edge	0.5			Ts
t17	Line Pulse Falling edge to DRDY active	note 7		250	

1. Ts = pixel clock period
2. t6min =  $[(\text{REG}[04\text{h}] \text{ bits } 6-0)+1] \times 8 + [(\text{REG}[08\text{h}] \text{ bits } 4-0)+4] \times 8] \text{ Ts}$
3. t8 min =  $[(\text{REG}[06\text{h}] \text{ bits } 1-0, \text{REG}[05\text{h}] \text{ bits } 7-0)+1] + (\text{REG}[0A\text{h}] \text{ bits } 6-0)] \text{ Lines}$
4. t10min =  $[(\text{REG}[04\text{h}] \text{ bits } 6-0)+1] \times 8] \text{ Ts}$
5. t14min =  $[(\text{REG}[04\text{h}] \text{ bits } 6-0)+1] \times 8] \text{ Ts}$
6. t15min =  $[(\text{REG}[07\text{h}] \text{ bits } 4-0) \times 8 + 16] \text{ Ts}$
7. t17min =  $[(\text{REG}[08\text{h}] \text{ bits } 4-0) - (\text{REG}[07]) \times 8 + 16] \text{ Ts}$

## 8 Registers

### 8.1 Register Mapping

The S1D13705 registers are located in the upper 32 bytes of the 128K byte S1D13705 address range. The registers are accessible when CS# = 0 and AB[16:0] are in the range 1FFE0h through 1FFFFh.

### 8.2 Register Descriptions

Unless specified otherwise, all register bits are reset to 0 during power up. All bits marked n/a should be programmed 0.

REG[00h] Revision Code Register							Read Only.
Address = 1FFE0h							
Product Code Bit 5	Product Code Bit 4	Product Code Bit 3	Product Code Bit 2	Product Code Bit 1	Product Code Bit 0	Revision Code Bit 1	Revision Code Bit 0

- bits 7-2                      Product Code  
This is a read-only register that indicates the product code of the chip. The product code is 001001.
- bits 1-0                      Revision Code  
This is a read-only register that indicates the revision code of the chip. The revision code is 00.

REG[01h] Mode Register 0							Read/Write.
Address = 1FFE1h							
TFT/STN	Dual/Single	Color/Mono	FPLine Polarity	FPFrame Polarity	Mask FPSHIFT	Data Width Bit 1	Data Width Bit 0

- bit 7                              TFT/STN  
When this bit = 0, STN (passive) panel mode is selected. When this bit = 1, TFT/D-TFD panel mode is selected. If TFT/D-TFD panel mode is selected, Dual/Single (REG[01h] bit 6) and Color/Mono (REG[01h] bit 5) are ignored. See Table 8-1: "Panel Data Format" for a comprehensive description of panel selection.
- bit 6                              Dual/Single  
When this bit = 0, Single LCD panel drive is selected. When this bit = 1, Dual LCD panel drive is selected. See Table 8-1: "Panel Data Format" for a comprehensive description of panel selection.
- bit 5                              Color/Mono  
When this bit = 0, Monochrome LCD panel drive is selected. When this bit = 1, Color LCD panel drive is selected. See Table 8-1: "Panel Data Format" for a comprehensive description of panel selection.

- bit 4 **FPLINE Polarity**  
This bit controls the polarity of FPLINE in TFT/D-TFD mode (no effect in passive panel mode). When this bit = 0, FPLINE is active low. When this bit = 1, FPLINE is active high.
- bit 3 **FPFRAME Polarity**  
This bit controls the polarity of FPFRAME in TFT/D-TFD mode (no effect in passive panel mode). When this bit = 0, FPFRAME is active low. When this bit = 1, FPFRAME is active high.
- bit 2 **Mask FPSHIFT**  
FPSHIFT is masked during non-display periods if either of the following two criteria is met:
1. Color passive panel is selected (REG[01h] bit 5 = 1)
  2. This bit (REG[01h] bit 2) = 1
- bits 1-0 **Data Width Bits [1:0]**  
These bits select the display data format. See Table 8-1: “Panel Data Format” below for a comprehensive description of panel selection.

Table 8-1: Panel Data Format

TFT/STN REG[01h] bit 7	Color/Mono REG[01h] bit 5	Dual/Single REG[01h] bit 6	Data Width Bit 1 REG[01h] bit 1	Data Width Bit 0 REG[01h] bit 0	Function
0	0	0	0	0	Mono Single 4-bit passive LCD
				1	Mono Single 8-bit passive LCD
			1	0	reserved
		1		reserved	
		1	0	0	reserved
				1	Mono Dual 8-bit passive LCD
	1	0	0	0	Color Single 4-bit passive LCD
				1	Color Single 8-bit passive LCD format 1
			1	0	reserved
				1	Color Single 8-bit passive LCD format 2
		1	0	0	reserved
				1	Color Dual 8-bit passive LCD
			1	0	reserved
				1	reserved
1	X (don't care)		0	9-bit TFT/D-TFD panel	
			1	12-bit TFT/D-TFD panel	

REG[02h] Mode Register 1							Read/Write.
Address = 1FFE2h							
Bit-Per-Pixel Bit 1	Bit-Per-Pixel Bit 0	High Performance	Input Clock divide (CLKI/2)	Display Blank	Frame Repeat	Hardware Video Invert Enable	Software Video Invert

bits 7-6

Bit-Per-Pixel Bits [1:0]

These bits select the color or gray-scale depth (Display Mode).

Table 8-2: Gray Scale/Color Mode Selection

Color/Mono REG[01h] bit 5	Bit-Per-Pixel Bit 1 REG[02h] bit 7	Bit-Per-Pixel Bit 0 REG[02h] bit 6	Display Mode	
0	0	0	2 Gray scale	1 bit-per-pixel
		1	4 Gray scale	2 bit-per-pixel
	1	0	16 Gray scale	4 bit-per-pixel
		1	reserved	
1	0	0	2 Colors	1 bit-per-pixel
		1	4 Colors	2 bit-per-pixel
	1	0	16 Colors	4 bit-per-pixel
		1	256 Colors	8 bit-per-pixel

bit 5

High Performance (Landscape Modes Only)

When this bit = 0, the internal Memory Clock (MCLK) is a divided-down version of the Pixel Clock (PCLK). The denominator is dependent on the bit-per-pixel mode - see the table below.

Table 8-3: High Performance Selection

High Performance	BPP Bit 1	BPP Bit 0	Display Modes	
0	0	0	MClk = PClk/8	1 bit-per-pixel
		1	MClk = PClk/4	2 bit-per-pixel
	1	0	MClk = PClk/2	4 bit-per-pixel
		1	MClk = PClk	8 bit-per-pixel
1	X	X	MClk = PClk	

When this bit = 1, MCLK is fixed to the same frequency as PCLK for all bit-per-pixel modes. This provides a faster screen update performance in 1/2/4 bit-per-pixel modes, but also increases power consumption. This bit can be set to 1 just before a major screen update, then set back to 0 to save power after the update. This bit has no effect in Swivel-View mode. Refer to REG[1Bh] SwivelView Mode Register on page 67 for SwivelView mode clock selection.

- bit 4**                    Input Clock Divide  
When this bit = 0, the Operating Clock(CLK) is the same as the Input Clock (CLKI).  
When this bit = 1, CLK = CLKI/2.
- In landscape mode PCLK=CLK and MCLK is selected as per Table 8-3: “High Performance Selection”.
- In SwivelView mode, MCLK and PCLK are derived from CLK as shown in Table 8-8: “Selection of PCLK and MCLK in SwivelView Mode,” on page 68.
- bit 3**                    Display Blank  
This bit blanks the display image. When this bit = 1, the display is blanked (FPDAT lines to the panel are driven low). When this bit = 0, the display is enabled.
- bit 2**                    Frame Repeat (EL support)  
This feature is used to improve Frame Rate Modulation of EL panels. When this bit = 1, an internal frame counter runs from 0 to 3FFFFh. When the frame counter rolls over, the modulated image pattern is repeated (every 1 hour when the frame rate is 72Hz). When this bit = 0, the modulated image pattern is never repeated.
- bit 1**                    Hardware Video Invert Enable  
In passive panel modes (REG[01h] bit 7 = 0) FPDAT11 is available as either GPIO4 or hardware video invert. When this bit = 1, Hardware Video Invert is enabled via the FPDAT11 pin. When this bit = 0, FPDAT11 operates as GPIO4. See Table 8-4: “Inverse Video Mode Select Options” below.

**Note**

Video data is inverted after the Look-Up Table.

- bit 0**                    Software Video Invert  
When this bit = 1, Inverse Video Mode is selected. When this bit = 0, Standard Video Mode is selected. See Table 8-4: “Inverse Video Mode Select Options” below.

**Note**

Video data is inverted after the Look-Up Table.

*Table 8-4: Inverse Video Mode Select Options*

Hardware Video Invert Enable	Software Video Invert (Passive and Active Panels)	FPDAT11 (Passive Panels Only)	Video Data
0	0	X	Normal
0	1	X	Inverse
1	X	0	Normal
1	X	1	Inverse



REG[03h] Mode Register 2							Read/Write
Address = 1FFE3h							
n/a	n/a	n/a	n/a	LCDPWR Override	Hardware Power Save Enable	Software Power Save Bit 1	Software Power Save Bit 0

- bit 3                      LCDPWR Override  
This bit is used to override the panel on/off sequencing logic. When this bit = 0, LCDPWR and the panel interface signals are controlled by the sequencing logic. When this bit = 1, LCDPWR is forced to off and the panel interface signals are forced low immediately upon entering power save mode. See Section 7.3.2, “Power Down/Up Timing” on page 37 for further information.
- bit 2                      Hardware Power Save Enable  
When this bit = 1 GPIO0 is used as the Hardware Power Save input pin. When this bit = 0, GPIO0 operates normally.

Table 8-5: Hardware Power Save/GPIO0 Operation

RESET# State	Hardware Power Save Enable REG[03h] bit 2	GPIO0 Config REG[18h] bit 0	GPIO0 Status/Control REG[19h] bit 0	GPIO0 Operation
0	X	X	X	
1	0	0	reads pin status	GPIO0 Input (high impedance)
1	0	1	0	GPIO0 Output = 0
1	0	1	1	GPIO0 Output = 1
1	1	X	X	Hardware Power Save Input (active high)

- bits 1-0                      Software Power Save Bits [1: 0]  
These bits select the Power Save Mode as shown in the following table.

Table 8-6: Software Power Save Mode Selection

Bit 1	Bit 0	Mode
0	0	Software Power Save
0	1	reserved
1	0	reserved
1	1	Normal Operation

Refer to Section 13, “Power Save Modes” on page 82 for a complete description of the power save modes.

<b>REG[04h] Horizontal Panel Size Register</b>							Read/Write
Address = 1FFE4h							
n/a	Horizontal Panel Size Bit 6	Horizontal Panel Size Bit 5	Horizontal Panel Size Bit 4	Horizontal Panel Size Bit 3	Horizontal Panel Size Bit 2	Horizontal Panel Size Bit 1	Horizontal Panel Size Bit 0

bits 6-0

Horizontal Panel Size Bits [6:0]

This register determines the horizontal resolution of the panel. This register must be programmed with a value calculated as follows:

$$\text{HorizontalPanelSizeRegister} = \left( \frac{\text{HorizontalPanelResolution(pixels)}}{8} \right) - 1$$

**Note**

This register must not be set to a value less than 03h.

<b>REG[05h] Vertical Panel Size Register (LSB)</b>							Read/Write
Address = 1FFE5h							
Vertical Panel Size Bit 7	Vertical Panel Size Bit 6	Vertical Panel Size Bit 5	Vertical Panel Size Bit 4	Vertical Panel Size Bit 3	Vertical Panel Size Bit 2	Vertical Panel Size Bit 1	Vertical Panel Size Bit 0

<b>REG[06h] Vertical Panel Size Register (MSB)</b>							Read/Write
Address = 1FFE6h							
n/a	n/a	n/a	n/a	n/a	n/a	Vertical Panel Size Bit 9	Vertical Panel Size Bit 8

REG[05h] bits 7-0

Vertical Panel Size Bits [9:0]

REG[06h] bits 1-0

This 10-bit register determines the vertical resolution of the panel. This register must be programmed with a value calculated as follows:

$$\text{VerticalPanelSizeRegister} = \text{VerticalPanelResolution(lines)} - 1$$

3FFh is the maximum value of this register for a vertical resolution of 1024 lines.

REG[07h] FPLINE Start Position							Read/Write
Address = 1FFE7h							
n/a	n/a	n/a	FPLINE Start Position Bit 4	FPLINE Start Position Bit 3	FPLINE Start Position Bit 2	FPLINE Start Position Bit 1	FPLINE Start Position Bit 0

bits 4-0

**FPLINE Start Position**

These bits are used in TFT/D-TFD mode to specify the position of the FPLINE pulse. These bits specify the delay, in 8-pixel resolution, from the end of a line of display data (FPDAT) to the leading edge of FPLINE. This register is effective in TFT/D-TFD mode only (REG[01h] bit 7 = 1). This register is programmed as follows:

$$\text{FPLINEposition(pixels)} = (\text{REG}[07\text{h}] + 2) \times 8$$

The following constraint must be satisfied:

$$\text{REG}[07\text{h}] \leq \text{REG}[08\text{h}]$$

REG[08h] Horizontal Non-Display Period							Read/Write
Address = 1FFE8h							
n/a	n/a	n/a	Horizontal Non-Display Period Bit 4	Horizontal Non-Display Period Bit 3	Horizontal Non-Display Period Bit 2	Horizontal Non-Display Period Bit 1	Horizontal Non-Display Period Bit 0

bits 4-0

**Horizontal Non-Display Period**

These bits specify the horizontal non-display period in 8-pixel resolution.

$$\text{HorizontalNonDisplayPeriod(pixels)} = (\text{REG}[08\text{h}] + 4) \times 8$$

REG[09h] FPFRAME Start Position							Read/Write
Address = 1FFE9h							
n/a	n/a	FPFRAME Start Position Bit 5	FPFRAME Start Position Bit 4	FPFRAME Start Position Bit 3	FPFRAME Start Position Bit 2	FPFRAME Start Position Bit 1	FPFRAME Start Position Bit 0

bits 5-0

**FPFRAME Start Position**

These bits are used in TFT/D-TFD mode to specify the position of the FPFRAME pulse. These bits specify the number of lines between the last line of display data (FPDAT) and the leading edge of FPFRAME. This register is effective in TFT/D-TFD mode only (REG[01h] bit 7 = 1). This register is programmed as follows:

$$\text{FPFRAMEposition(lines)} = \text{REG}[09\text{h}]$$

The contents of this register must be greater than zero and less than or equal to the Vertical Non-Display Period Register, i.e.

$$1 \leq \text{REG}[09\text{h}] \leq \text{REG}[0A\text{h}]\text{Bits } 5:0$$

<b>REG[0Ah] Vertical Non-Display Period</b>							Read/Write
Address = 1FFEAh							
Vertical Non-Display Status	n/a	Vertical Non-Display Period Bit 5	Vertical Non-Display Period Bit 4	Vertical Non-Display Period Bit 3	Vertical Non-Display Period Bit 2	Vertical Non-Display Period Bit 1	Vertical Non-Display Period Bit 0

bit 7                      Vertical Non-Display Status  
This bit =1 during the Vertical Non-Display period.

bits 5-0                 Vertical Non-Display Period  
These bits specify the vertical non-display period. This register is programmed as follows:

$$\text{VerticalNonDisplayPeriod}(\text{lines}) = \text{REG}[0\text{Ah}] \text{ bits } [5:0]$$

**Note**

This register should be set only once, on power-up during initialization.

<b>REG[0Bh] MOD Rate Register</b>							Read/Write
Address = 1FEBh							
n/a	n/a	MOD Rate Bit 5	MOD Rate Bit 4	MOD Rate Bit 3	MOD Rate Bit 2	MOD Rate Bit 1	MOD Rate Bit 0

bits 5-0                 MOD Rate Bits [5:0]  
When the value of this register is 0, the MOD output signal toggles every FPFRAME. For a non-zero value, the value in this register + 1 specifies the number of FPLINEs between toggles of the MOD output signal. These bits are for passive LCD panels only.

REG[0Ch] Screen 1 Start Address Register (LSB)							Read/Write
Address = 1FFECh							
Screen 1 Start Address Bit 7	Screen 1 Start Address Bit 6	Screen 1 Start Address Bit 5	Screen 1 Start Address Bit 4	Screen 1 Start Address Bit 3	Screen 1 Start Address Bit 2	Screen 1 Start Address Bit 1	Screen 1 Start Address Bit 0

REG[0Dh] Screen 1 Start Address Register (MSB)							Read/Write
Address = 1FFEDh							
Screen 1 Start Address Bit 15	Screen 1 Start Address Bit 14	Screen 1 Start Address Bit 13	Screen 1 Start Address Bit 12	Screen 1 Start Address Bit 11	Screen 1 Start Address Bit 10	Screen 1 Start Address Bit 9	Screen 1 Start Address Bit 8

REG[0Dh] bits 7-0      Screen 1 Start Address Bits [15:0]  
 REG[0Ch] bits 7-0      These bits determine the **word address** of the start of Screen 1 in Landscape modes or the **byte address** of the start of Screen 1 in SwivelView modes.

**Note**

For SwivelView mode the most significant bit (bit 16) is located in REG[10h].

REG[0Eh] Screen 2 Start Address Register (LSB)							Read/Write
Address = 1FFEEh							
Screen 2 Start Address Bit 7	Screen 2 Start Address Bit 6	Screen 2 Start Address Bit 5	Screen 2 Start Address Bit 4	Screen 2 Start Address Bit 3	Screen 2 Start Address Bit 2	Screen 2 Start Address Bit 1	Screen 2 Start Address Bit 0

REG[0Fh] Screen 2 Start Address Register (MSB)							Read/Write
Address = 1FFEFh							
Screen 2 Start Address Bit 15	Screen 2 Start Address Bit 14	Screen 2 Start Address Bit 13	Screen 2 Start Address Bit 12	Screen 2 Start Address Bit 11	Screen 2 Start Address Bit 10	Screen 2 Start Address Bit 9	Screen 2 Start Address Bit 8

REG[0Fh] bits 7-0      Screen 2 Start Address Bits [15:0]  
 REG[0Eh] bits 7-0      These bits determine the **word address** of the start of Screen 2 in Landscape modes only and has no effect in SwivelView modes.

REG[10h] Screen Start Address Overflow Register							Read/Write
Address = 1FFF0h							
n/a	n/a	n/a	n/a	n/a	n/a	n/a	Screen 1 Start Address Bit 16

bit 0      Screen 1 Start Address Bit 16  
 This bit is the most significant bit of Screen 1 Start Address for SwivelView mode. This bit has no effect in Landscape mode.

<b>REG[11h] Memory Address Offset Register</b>							Read/Write
Address = 1FFF1h							
Memory Address Offset Bit 7	Memory Address Offset Bit 6	Memory Address Offset Bit 5	Memory Address Offset Bit 4	Memory Address Offset Bit 3	Memory Address Offset Bit 2	Memory Address Offset Bit 1	Memory Address Offset Bit 0

bits 7-0

Memory Address Offset Bits [7:0] (Landscape Modes Only)

This register is used to create a virtual image by setting a word offset between the last address of one line and the first address of the following line. If this register is not equal to zero, then a virtual image is formed. The displayed image is a window into the larger virtual image. See Figure 8-1: “Screen-Register Relationship, Split Screen,” on page 65.

This register has no effect in SwivelView modes. See “REG[1Ch] Line Byte Count Register for SwivelView Mode” on page 68.

<b>REG[12h] Screen 1 Vertical Size Register (LSB)</b>							Read/Write
Address = 1FFF2h							
Screen 1 Vertical Size Bit 7	Screen 1 Vertical Size Bit 6	Screen 1 Vertical Size Bit 5	Screen 1 Vertical Size Bit 4	Screen 1 Vertical Size Bit 3	Screen 1 Vertical Size Bit 2	Screen 1 Vertical Size Bit 1	Screen 1 Vertical Size Bit 0

<b>REG[13h] Screen 1 Vertical Size Register (MSB)</b>							Read/Write
Address = 1FFF3h							
n/a	n/a	n/a	n/a	n/a	n/a	Screen 1 Vertical Size Bit 9	Screen 1 Vertical Size Bit 8

REG[13h] bits 1-0

Screen 1 Vertical Size Bits [9:0]

REG[12h] bits 7-0

This register is used to implement the Split Screen feature of the S1D13705. These bits determine the height (in lines) of Screen 1.

In landscape modes, if this register is programmed with a value, n, where n is less than the Vertical Panel Size (REG[06h], REG[05h]), then lines 0 to n of the panel contain Screen 1 and lines n+1 to REG[06h], REG[05h] of the panel contain Screen 2. See Figure 8-1: “Screen-Register Relationship, Split Screen,” on page 65. If Split Screen is not desired, this register must be programmed greater than, or equal to the Vertical Panel Size, REG[06h] and REG[05h].

In SwivelView modes this register must be programmed greater than, or equal to the Vertical Panel Size, REG[06h] and REG[05h]. See “SwivelView™” on page 77.

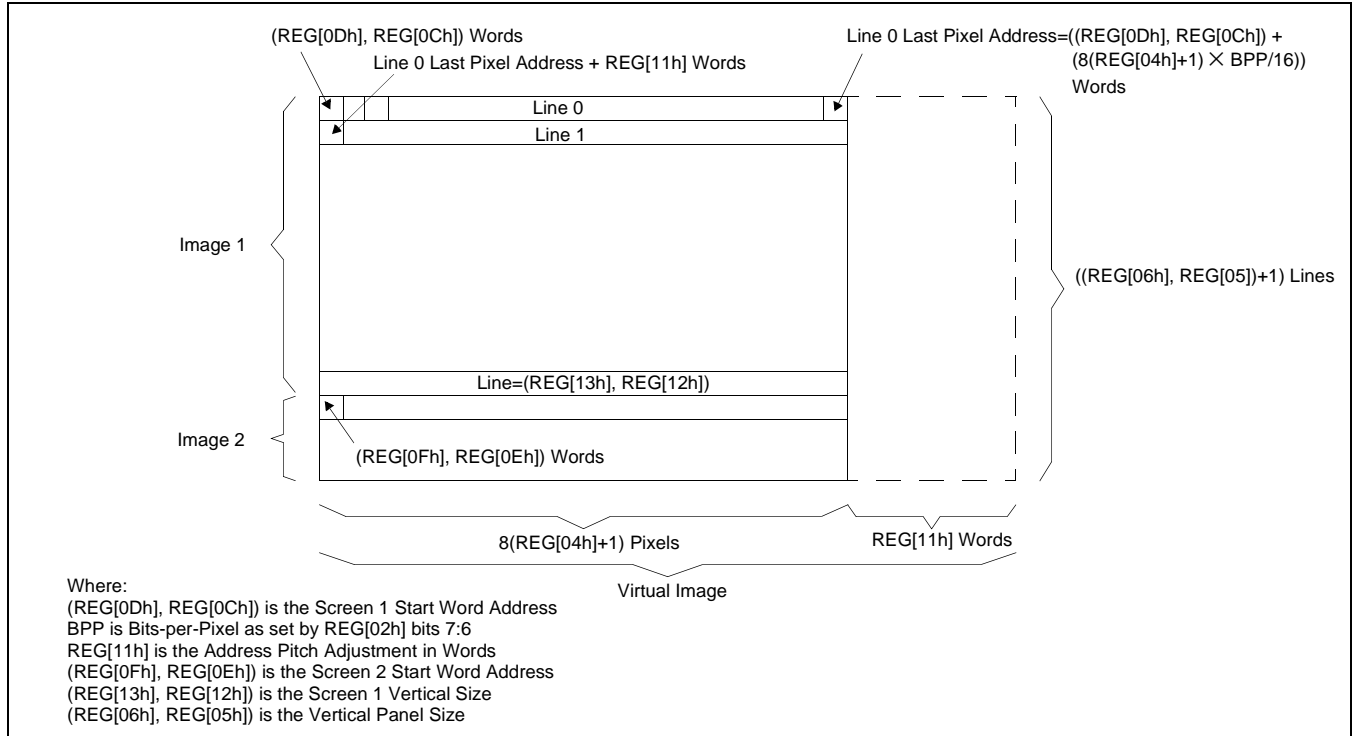

Figure 8-1: Screen-Register Relationship, Split Screen

Consider an example where REG[13h], REG[12] = 0CEh for a 320x240 display system. The upper 207 lines (CEh + 1) of the panel show an image from the Screen 1 Start Word Address. The remaining 33 lines show an image from the Screen 2 Start Word Address.

**REG[15h] Look-Up Table Address Register**

Address = 1FFF5h

Read/Write

LUT Address Bit 7	LUT Address Bit 6	LUT Address Bit 5	LUT Address Bit 4	LUT Address Bit 3	LUT Address Bit 2	LUT Address Bit 1	LUT Address Bit 0
-------------------	-------------------	-------------------	-------------------	-------------------	-------------------	-------------------	-------------------

bits 7-0

LUT Address Bits [7:0]

These 8 bits control a pointer into the Look-Up Tables (LUT). The S1D13705 has three 256-position, 4-bit wide LUTs, one for each of red, green, and blue – refer to Section 11, “Look-Up Table Architecture” on page 71 for details.

This register selects which LUT entry is read/write accessible through the LUT Data Register (REG[17h]). Writing the LUT Address Register automatically sets the pointer to the Red LUT. Accesses to the LUT Data Register automatically increment the pointer.

For example, writing a value 03h into the LUT Address Register sets the pointer to R[3]. A subsequent access to the LUT Data Register accesses R[3] and moves the pointer onto G[3]. Subsequent accesses to the LUT Data Register move the pointer onto B[3], R[4], G[4], B[4], R[5], etc.

**Note**

The RGB data is inserted into the LUT after the Blue data is written, i.e. all three colors must be written before the LUT is updated.

REG[17h] Look-Up Table Data Register							Read/Write
Address = 1FFF7h							
LUT Data Bit 3	LUT Data Bit 2	LUT Data Bit 1	LUT Data Bit 0	n/a	n/a	n/a	n/a

bits 7-4

LUT Data Bits [3:0]

This register is used to read/write the RGB Look-Up Tables. This register accesses the entry at the pointer controlled by the Look-Up Table Address Register (REG[15h]).

Accesses to the Look-Up Table Data Register automatically increment the pointer.

**Note**

The RGB data is inserted into the LUT after the Blue data is written, i.e. all three colors must be written before the LUT is updated.

REG[18h] GPIO Configuration Control Register							Read/Write
Address = 1FFF8h							
n/a	n/a	n/a	GPIO4 Pin IO Configuration	GPIO3 Pin IO Configuration	GPIO2 Pin IO Configuration	GPIO1 Pin IO Configuration	GPIO0 Pin IO Configuration

bits 4-0

GPIO[4:0] Pin IO Configuration

These bits determine the direction of the GPIO[4:0] pins.

When the GPIO<sub>n</sub> Pin IO Configuration bit = 0, the corresponding GPIO<sub>n</sub> pin is configured as an input. The input can be read at the GPIO<sub>n</sub> Status/Control Register bit. See REG[19h] GPIO Status/Control Register.

When the GPIO<sub>n</sub> Pin IO Configuration bit = 1, the corresponding GPIO<sub>n</sub> pin is configured as an output. The output can be controlled by writing the GPIO<sub>n</sub> Status/Control Register bit.

**Note**

These bits have no effect when the GPIO<sub>n</sub> pin is configured for a specific function (i.e. as FPDAT[11:8] for TFT/D-TFD operation).

When configured as IO, all unused pins must be tied to IO  $V_{DD}$ .



<b>REG[19h] GPIO Status/Control Register</b>							Read/Write
Address = 1FFF9h							
n/a	n/a	n/a	GPIO4 Pin IO Status	GPIO3 Pin IO Status	GPIO2 Pin IO Status	GPIO1 Pin IO Status	GPIO0 Pin IO Status

bits 4-0                      GPIO[4:0] Status  
 When the GPIO pin is configured as an input, the corresponding GPIO Status bit is used to read the pin input. See REG[18h] above.  
 When the GPIO pin is configured as an output, the corresponding GPIO Status bit is used to control the pin output.

<b>REG[1Ah] Scratch Pad Register</b>							Read/Write
Address = 1FFFAh							
Scratch bit 7	Scratch bit 6	Scratch bit 5	Scratch bit 4	Scratch bit 3	Scratch bit 2	Scratch bit 1	Scratch bit 0

bits 7-0                      Scratch Pad Register  
 This register contains general use read/write bits. These bits have no effect on hardware.

<b>REG[1Bh] SwivelView Mode Register</b>							Read/Write
Address = 1FFFBh							
SwivelView Mode Enable	SwivelView Mode Select	n/a	n/a	n/a	reserved	SwivelView Mode Pixel Clock Select Bit 1	SwivelView Mode Pixel Clock Select Bit 0

bit 7                              SwivelView Mode Enable  
 When this bit = 1, SwivelView Mode is enabled. When this bit = 0, Landscape Mode is enabled.

bit 6                              SwivelView Mode Select  
 When this bit = 0, Default SwivelView Mode is selected. When this bit = 1, Alternate SwivelView Mode is selected. See Section 12, “SwivelView™” on page 77 for further information on SwivelView Mode.

The following table shows the selection of SwivelView Mode.

*Table 8-7: Selection of SwivelView Mode*

SwivelView Mode Enable (REG[1Bh] bit 7)	SwivelView Mode Select (REG[1Bh] bit 6)	Mode
0	X	Landscape
1	0	Default SwivelView
1	1	Alternate SwivelView

bit 2 reserved  
reserved bits must be set to 0.

bits 1-0 SwivelView Mode Pixel Clock Select Bits [1:0]  
These two bits select the Pixel Clock (PCLK) source in SwivelView Mode - these bits have no effect in Landscape Mode. The following table shows the selection of PCLK and MCLK in SwivelView Mode - see Section 12, “SwivelView™” on page 77 for details.

Table 8-8: Selection of PCLK and MCLK in SwivelView Mode

SwivelView Mode Enable (REG[1Bh] bit 7)	SwivelView Mode Select (REG[1Bh] bit 6)	Pixel Clock (PCLK) Select (REG[1Bh] bits [1:0])		PCLK =	MCLK =
		Bit 1	Bit 0		
0	X	X	X	CLK	See Reg[02h] bit 5
1	0	0	0	CLK	CLK
1	0	0	1	CLK/2	CLK/2
1	0	1	0	CLK/4	CLK/4
1	0	1	1	CLK/8	CLK/8
1	1	0	0	CLK/2	CLK
1	1	0	1	CLK/2	CLK
1	1	1	0	CLK/4	CLK/2
1	1	1	1	CLK/8	CLK/4

Where CLK is CLKI (REG[02h] bit 4 = 0) or CLKI/2 (REG[02h] bit 4 = 1)

#### REG[1Ch] Line Byte Count Register for SwivelView Mode

Address = 1FFFCh

Read/Write

Line Byte Count bit 7	Line Byte Count bit 6	Line Byte Count bit 5	Line Byte Count bit 4	Line Byte Count bit 3	Line Byte Count bit 2	Line Byte Count bit 1	Line Byte Count bit 0
-----------------------	-----------------------	-----------------------	-----------------------	-----------------------	-----------------------	-----------------------	-----------------------

bits 7-0 Line Byte Count Bits [7:0]

This register is the byte count from the beginning of one line to the beginning of the next consecutive line (commonly called “stride” by programmers). This register may be used to create a virtual image in SwivelView mode.

When this register = 00 the “stride” = 256 bytes. This value is used for 240x320 8 bpp default SwivelView mode

When the Line Byte Count Register = n, where  $1 \leq n \leq FFh$ , the “stride” = n bytes.

#### REG[1Eh] and REG[1Fh]

REG[1Eh] and REG[1Fh] are reserved for factory S1D13705 testing and should not be written. Any value written to these registers may result in damage to the S1D13705 and/or any panel connected to the S1D13705.

## 9 Frame Rate Calculation

The following formulae are used to calculate the display frame rate.

### TFT/D-TFD and Passive Single-Panel modes

$$\text{FrameRate} = \frac{f_{\text{PCLK}}}{(\text{HDP} + \text{HNDP}) \times (\text{VDP} + \text{VNDP})}$$

Where:  $f_{\text{PCLK}}$  = PCLK frequency (Hz)  
HDP = Horizontal Display Period = ((REG[04h] bits 6-0) + 1) x 8 Pixels  
HNDP = Horizontal Non-Display Period = ((REG[08h] bits 4-0) + 4) x 8 Pixels  
VDP = Vertical Display Period = ((REG[06h] bits 1-0, REG[05h] bits 7-0) + 1) Lines  
VNDP = Vertical Non-Display Period = (REG[0Ah] bits 5-0) Lines

### Passive Dual-Panel mode

$$\text{FrameRate} = \frac{f_{\text{PCLK}}}{2 \times (\text{HDP} + \text{HNDP}) \times \left(\frac{\text{VDP}}{2} + \text{VNDP}\right)}$$

Where:  $f_{\text{PCLK}}$  = PCLK frequency (Hz)  
HDP = Horizontal Display Period = ((REG[04h] bits 6-0) + 1) x 8 Pixels  
HNDP = Horizontal Non-Display Period = ((REG[08h] bits 4-0) + 4) x 8 Pixels  
VDP = Vertical Display Period = ((REG[06h] bits 1-0, REG[05h] bits 7-0) + 1) Lines  
VNDP = Vertical Non-Display Period = (REG[0Ah] bits 5-0) Lines

# 10 Display Data Formats

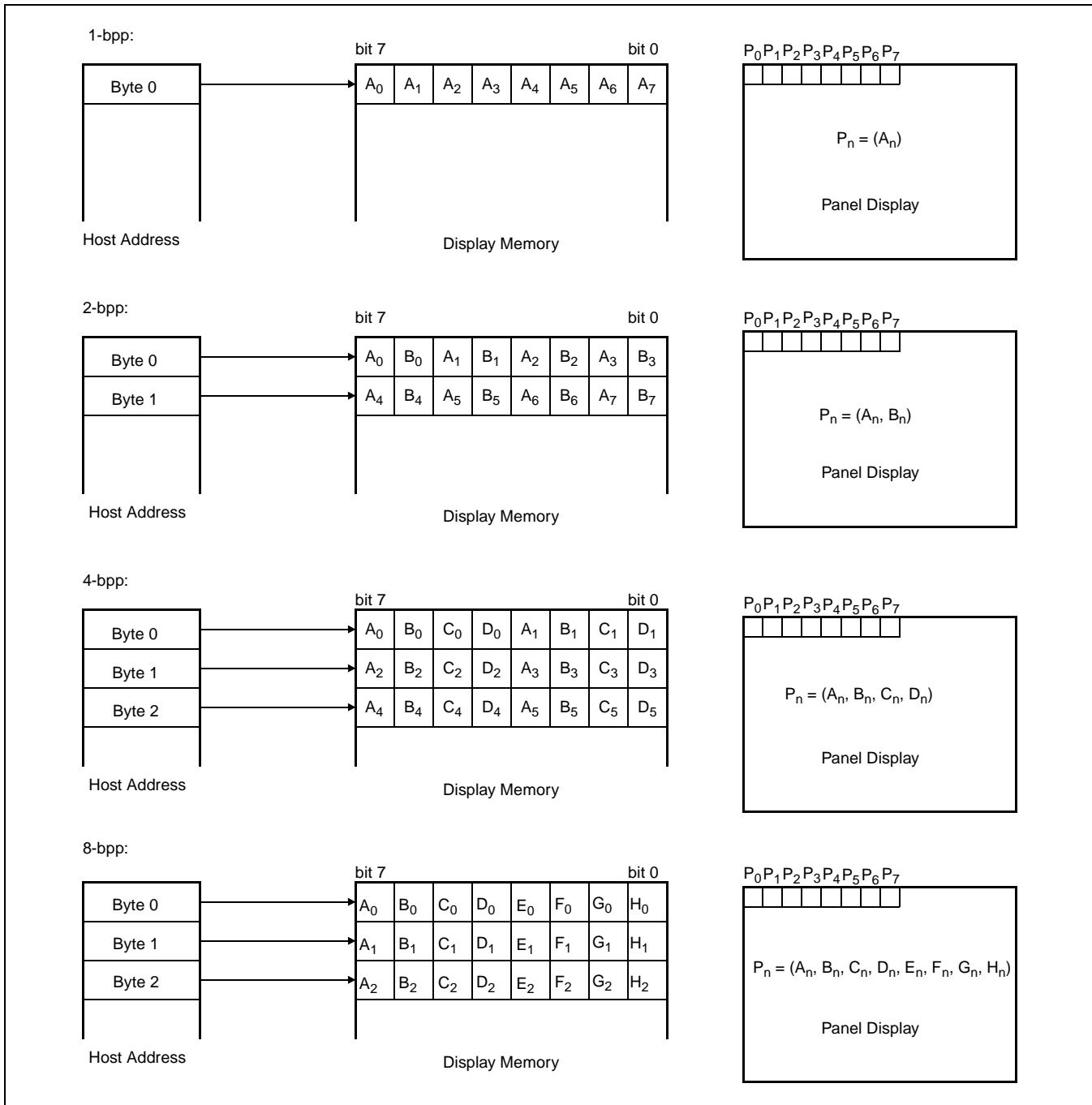

Figure 10-1: 1/2/4/8 Bit-Per-Pixel Display Data Memory Organization

# 11 Look-Up Table Architecture

The following figures are intended to show the display data output path only.

**Note**

When Video Data Invert is enabled the video data is inverted after the Look-Up Table.

## 11.1 Monochrome Modes

The green Look-Up Table (LUT) is used for all monochrome modes.

### 1 Bit-per-pixel Monochrome mode

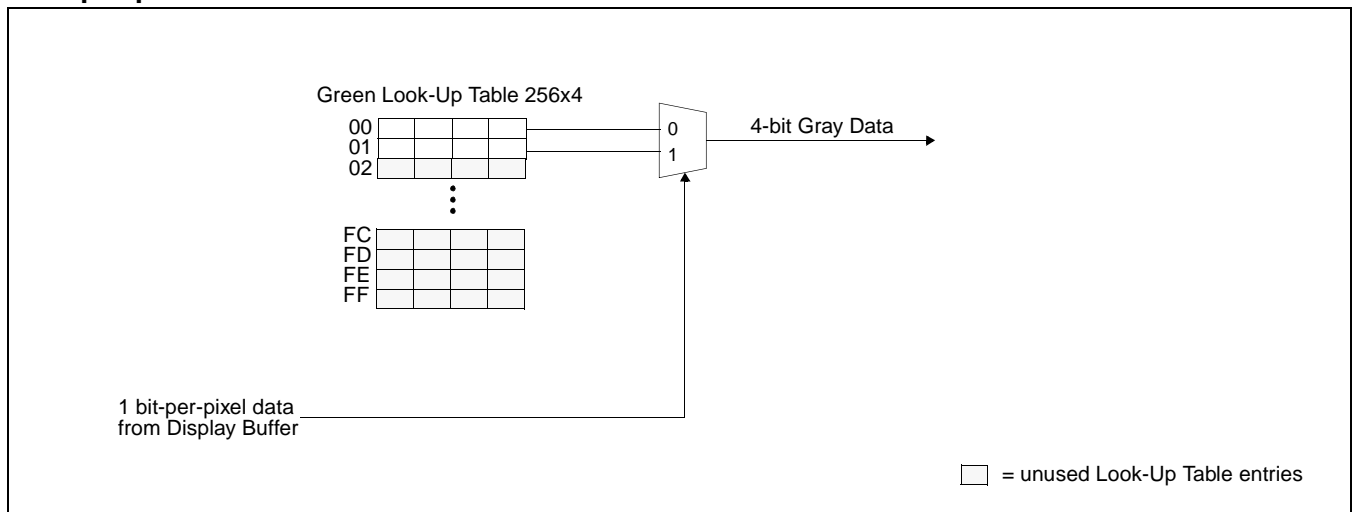

Figure 11-1: 1 Bit-per-pixel Monochrome Mode Data Output Path

### 2 Bit-per-pixel Monochrome Mode

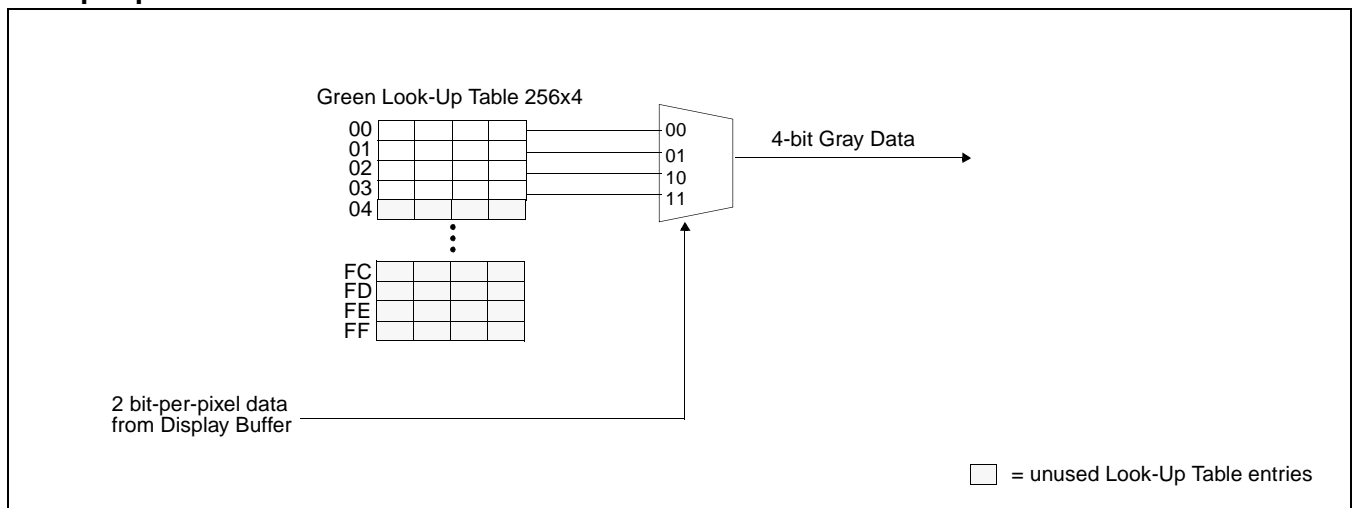

Figure 11-2: 2 Bit-per-pixel Monochrome Mode Data Output Path

### 4 Bit-per-pixel Monochrome Mode

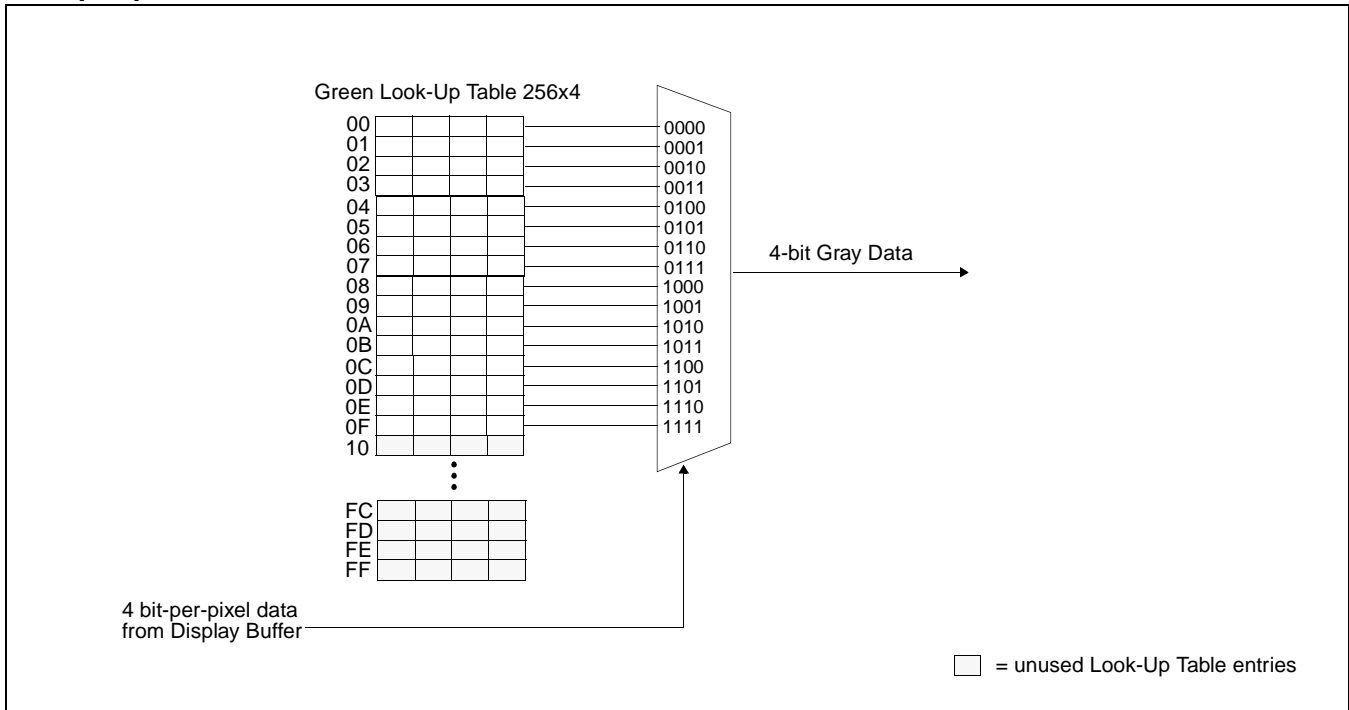

Figure 11-3: 4 Bit-per-pixel Monochrome Mode Data Output Path

## 11.2 Color Modes

### 1 Bit-per-pixel Color Mode

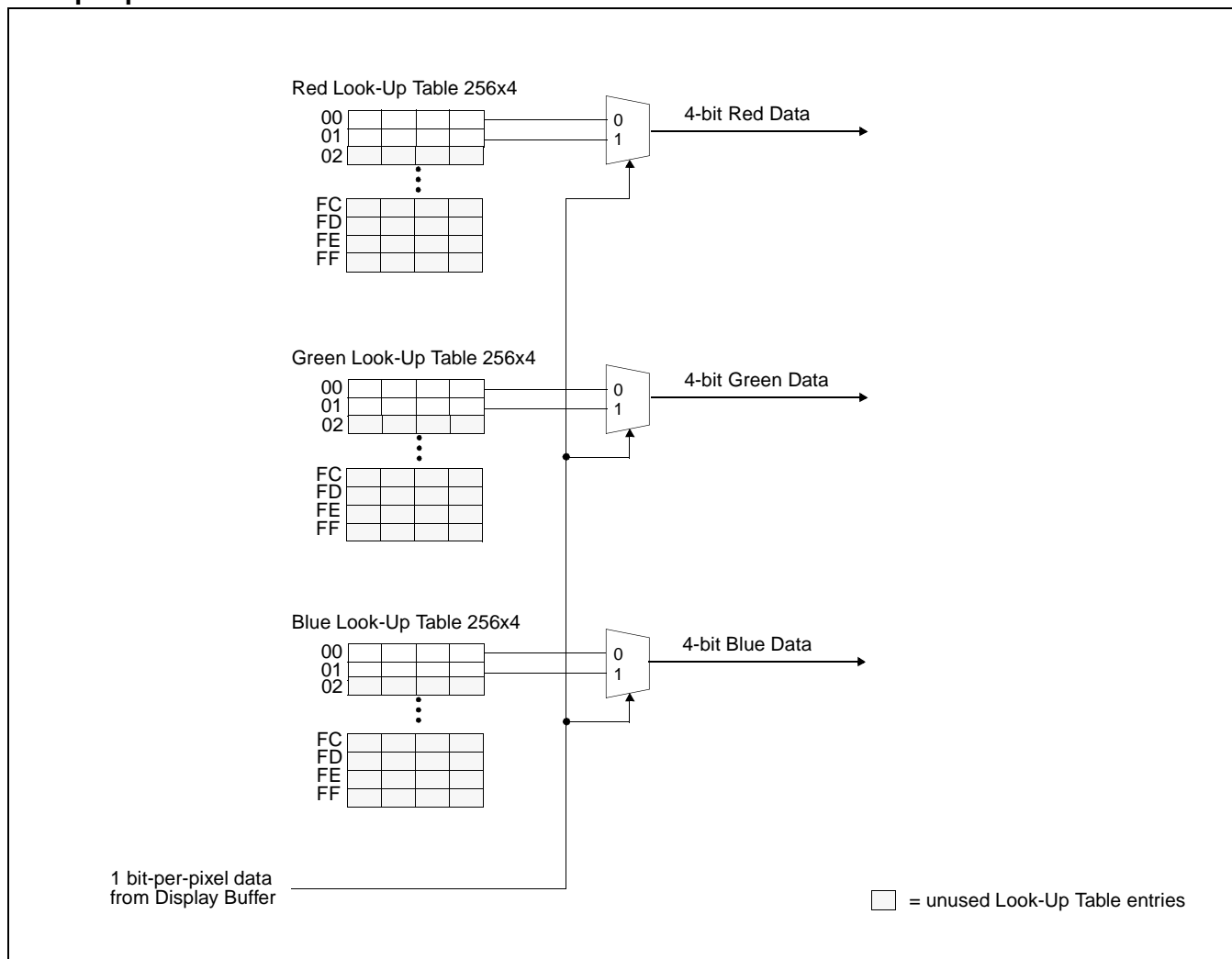

Figure 11-4: 1 Bit-per-pixel Color Mode Data Output Path

## 2 Bit-per-pixel Color Mode

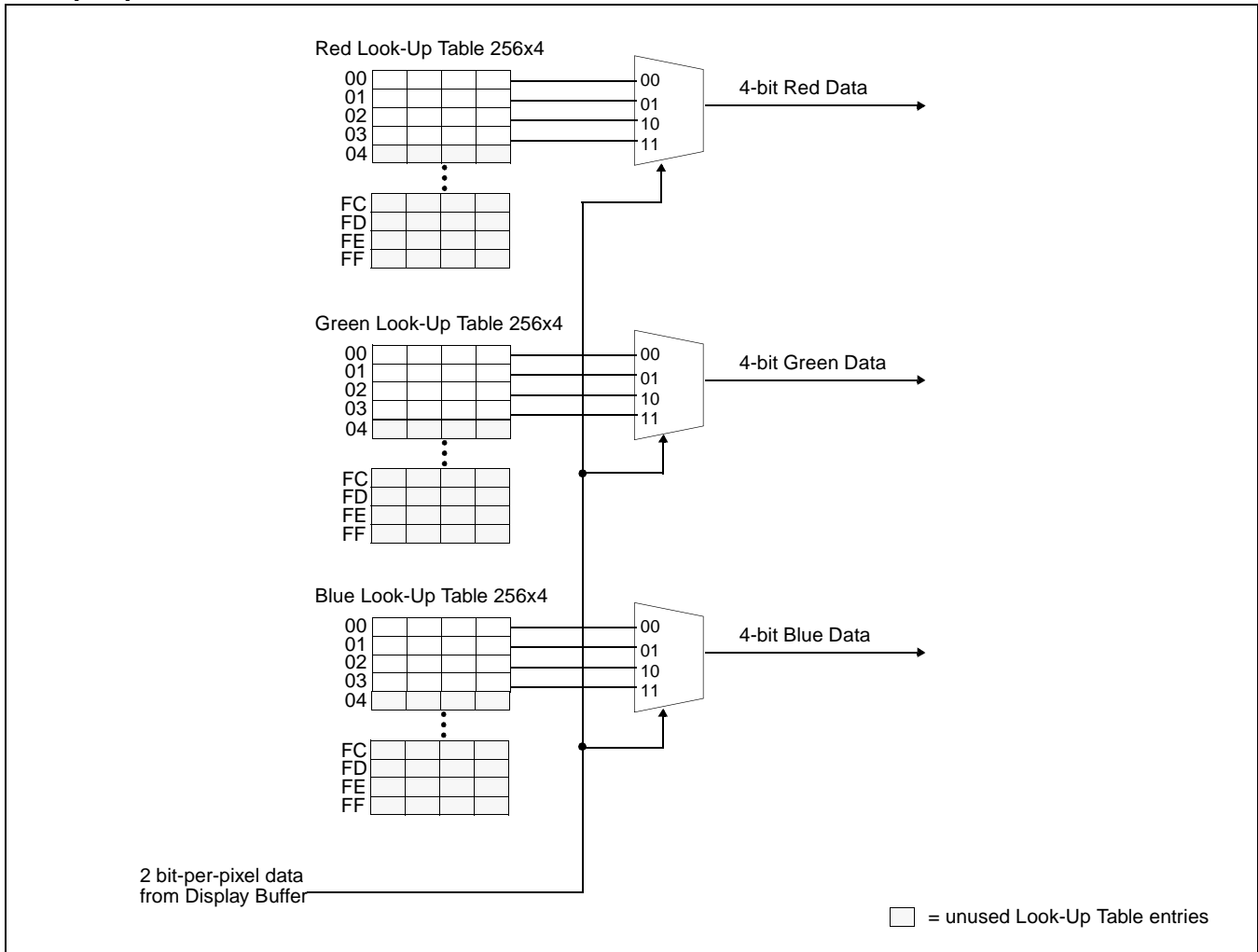

Figure 11-5: 2 Bit-per-pixel Color Mode Data Output Path



### 4 Bit-per-pixel Color Mode

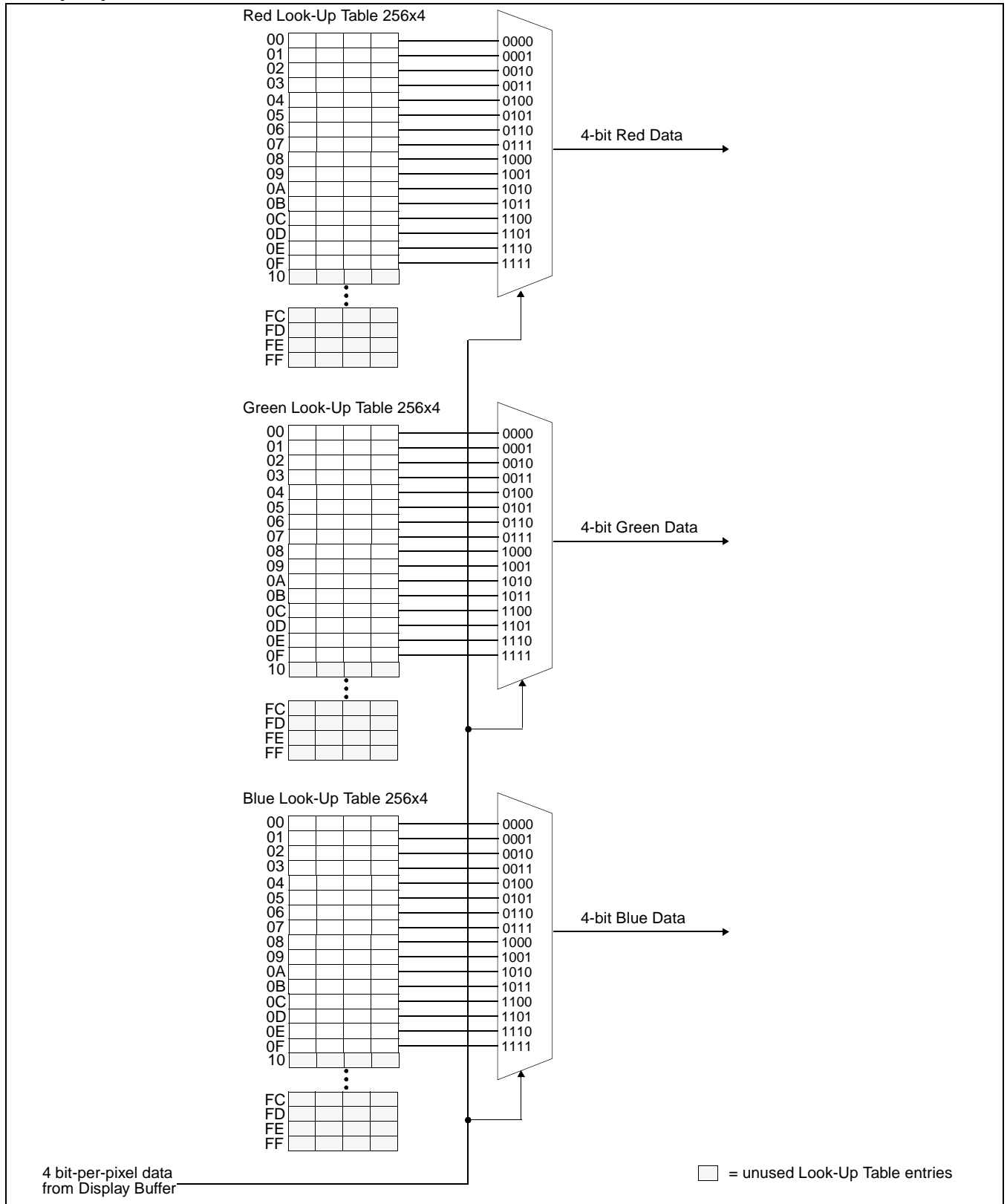

Figure 11-6: 4 Bit-per-pixel Color Mode Data Output Path

### 8 Bit-per-pixel Color Mode

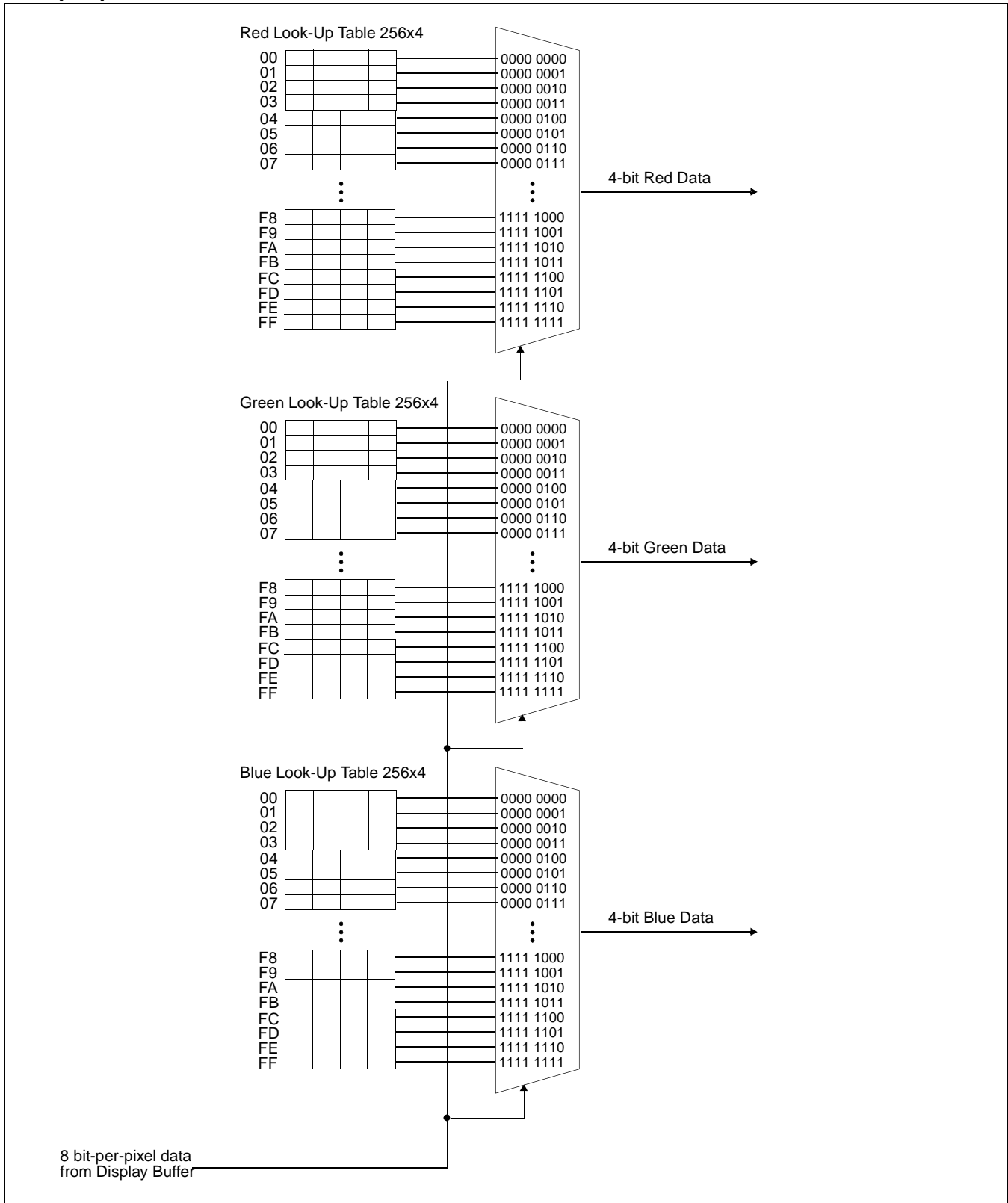

Figure 11-7: 8 Bit-per-pixel Color Mode Data Output Path

## 12 SwivelView™

Many of today's applications use the LCD panel in a portrait orientation. In this case it becomes necessary to “rotate” the displayed image by 90°. This rotation can be done by software at the expense of performance or, it can be done by the S1D13705 hardware with no CPU penalty.

There are two SwivelView modes: Default SwivelView Mode and Alternate SwivelView Mode.

### 12.1 Default SwivelView Mode

Default SwivelView Mode requires the SwivelView image width be a power of two, e.g. a 240-line panel requires a minimum virtual image width of 256. This mode should be used whenever the required virtual image can be contained within the integrated display buffer (i.e. virtual image size  $\leq$  80K bytes), as it consumes less power than the Alternate SwivelView Mode.

For example, the panel size is 320x240 and the display mode is 8 bit-per-pixel. The virtual image size is 320x256 which can be contained within the 80K Byte display buffer.

Default SwivelView Mode also requires Memory Clock (MCLK)  $\geq$  Pixel Clock (PCLK).

The following figure shows how the programmer sees a 240x320 image and how the image is displayed. The application image is written to the S1D13705 in the following sense: A–B–C–D. The display is refreshed by the S1D13705 in the following sense: B–D–A–C.

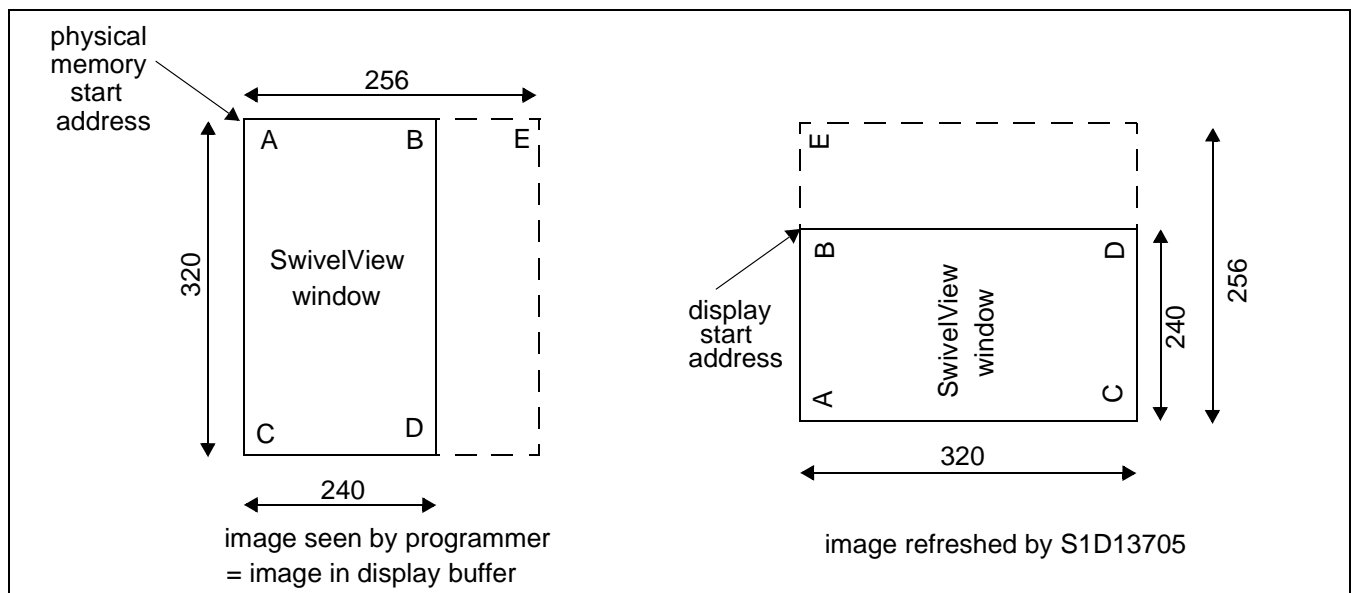

Figure 12-1: Relationship Between The Screen Image and the Image Refreshed by S1D13705 in Default Mode

### 12.1.1 How to Set Up Default SwivelView Mode

The following describes the register settings needed to set up Default SwivelView Mode for a 240x320x8 bpp image:

- Select Default SwivelView Mode: REG[1Bh] bit 7 = 1 and bit 6 = 0
- The display refresh circuitry starts at pixel “B”, therefore the Screen 1 Start Address register must be programmed with the address of pixel “B”, i.e.

$$\begin{aligned} \text{REG}[10\text{h}], \text{REG}[0\text{Dh}], \text{REG}[0\text{Ch}] &= \text{AddressOfPixelB} \\ &= (\text{AddressOfPixelA} + \text{ByteOffset}) \\ &= \text{AddressOfPixelA} + \left( \frac{240\text{pixels} \times 8\text{bpp}}{8\text{bpb}} \right) - 1 \\ &= \text{AddressOfPixelA} + \text{EFh} \end{aligned}$$

Where bpb is bits-per-byte and bpp is bits-per-pixel.

- The Line Byte Count Register for SwivelView Mode must be set to the virtual-image width in bytes, i.e.

$$\text{REG}[1\text{Ch}] = \frac{256}{(8\text{bpb}) \div (8\text{bpp})} = \frac{256}{1} = 256 = 00\text{h} \quad \text{:see REG}[1\text{Ch}] \text{ for explanation}$$

Where bpb is bits-per-byte and bpp is bits-per-pixel.

- Panning is achieved by changing the Screen 1 Start Address register:
  - Increment the register by 1 to pan horizontally by one byte, e.g. one pixel in 8 bpp mode
  - Increment the register by twice the effective value of the Line Byte Count register to pan vertically by two lines, e.g. add 200h to pan by two lines in the example above.

**Note**

Vertical panning by a single line is not supported in Default SwivelView Mode.

## 12.2 Alternate SwivelView Mode

Alternate SwivelView Mode may be used when the virtual image size of Default SwivelView Mode cannot be contained in the 80K byte integrated frame buffer. For example, the panel size is 480x320 and the display mode is 4 bit-per-pixel. The minimum virtual image size for Default SwivelView Mode would be 480x512 which requires 122,880 bytes. Alternate SwivelView Mode requires a panel size of only 480x320 which needs only 76,800 bytes.

Alternate SwivelView Mode requires the Memory Clock (MCLK) to be at least twice the frequency of the Pixel Clock (PCLK), i.e.  $MCLK \geq 2 \times PCLK$ . This makes the power consumption in Alternate SwivelView Mode higher than in Default SwivelView Mode while increasing performance.

The following figure shows how the programmer sees a 480x320 image and how the image is being displayed. The application image is written to the S1D13705 in the following sense: A-B-C-D. The display is refreshed by the S1D13705 in the following sense: B-D-A-C.

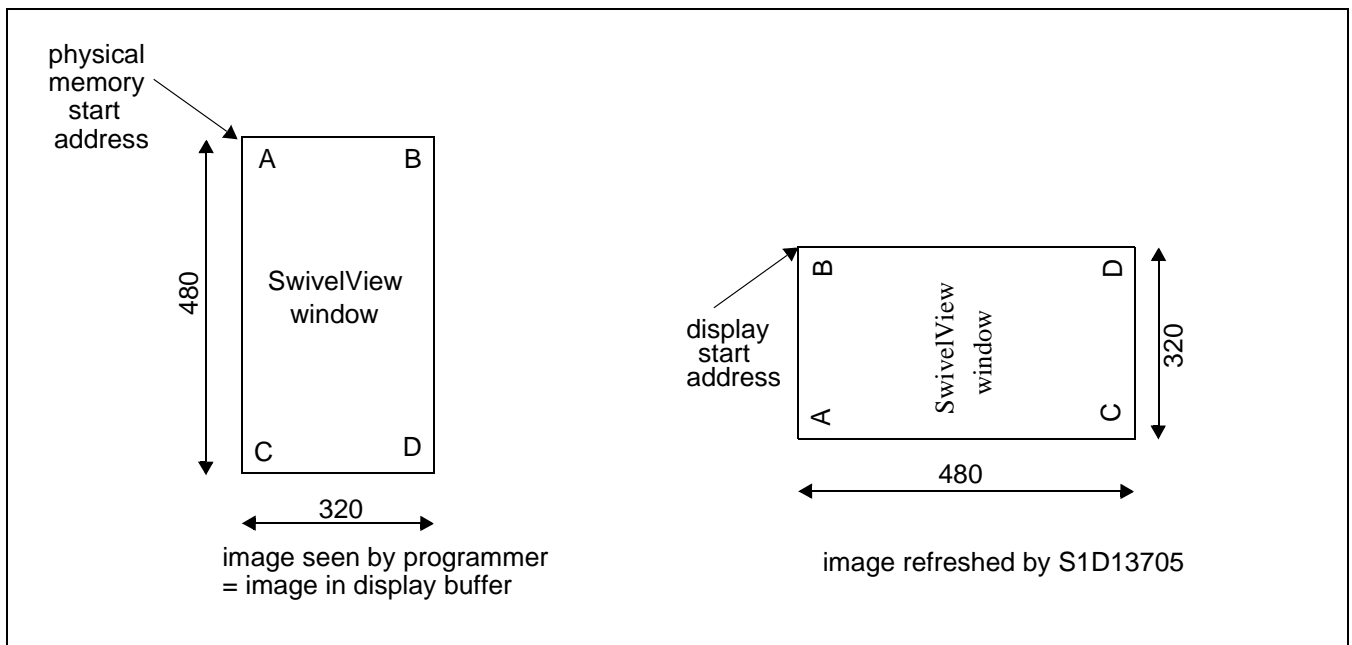

Figure 12-2: Relationship Between The Screen Image and the Image Refreshed by S1D13705 in Alternate Mode

## 12.2.1 How to Set Up Alternate SwivelView Mode

The following describes the register settings needed to set up Alternate SwivelView Mode for a 320x480x4 bpp image.

- Select Alternate SwivelView Mode:  
REG[1Bh] bit 7 = 1 and bit 6 = 1
- The display refresh circuitry starts at pixel “B”, therefore the Screen 1 Start Address register must be programmed with the address of pixel “B”, or

$$\begin{aligned} \text{REG}[10\text{h}], \text{REG}[0\text{Dh}], \text{REG}[0\text{Ch}] &= \text{AddressOfPixelB} \\ &= (\text{AddressOfPixelA} + \text{ByteOffset}) \\ &= \text{AddressOfPixelA} + \left( \frac{320\text{pixels} \times 4\text{bpp}}{8\text{bpb}} \right) - 1 \\ &= \text{AddressOfPixelA} + 9\text{Fh} \end{aligned}$$

Where bpb is bits-per-pixel and bpb is bits-per-byte.

- The Line Byte Count Register for SwivelView Mode must be set to the image width in bytes, i.e.

$$\text{REG}[1\text{Ch}] = \frac{320}{(8\text{bpb}) \div (4\text{bpp})} = \frac{320}{2} = 160 = \text{A0h}$$

Where bpb is bits-per-byte and bpb is bits-per-pixel.

- Panning is achieved by changing the Screen 1 Start Address register:
  - Increment the register by 1 to pan horizontally by one byte, e.g. two pixels in 4 bpp mode
  - Increment the register by the value in the Line Byte Count register to pan vertically by one line, e.g. add A0h to pan by one line in the example above

## 12.3 Comparison Between Default and Alternate SwivelView Modes

*Table 12-1: Default and Alternate SwivelView Mode Comparison*

Item	Default SwivelView Mode	Alternate SwivelView Mode
Memory Requirements	The width of the rotated image must be a power of 2. In most cases, a virtual image is required where the right-hand side of the virtual image is unused and memory is wasted. For example, a 320x480x4bpp image would normally require only 76,800 bytes - possible within the 80K byte address space, but the virtual image is 512x480x4bpp which needs 122,880 bytes - not possible.	Does not require a virtual image.
Clock Requirements	CLK need only be as fast as the required PCLK.	MCLK, and hence CLK, need to be 2x PCLK. For example, if the panel requires a 3MHz PCLK, then CLK must be 6MHz. Note that 25MHz is the maximum CLK, so PCLK cannot be higher than 12.5MHz in this mode.
Power Consumption	Lowest power consumption.	Higher than Default Mode.
Panning	Vertical panning in 2 line increments.	Vertical panning in 1 line increments.
Performance	Nominal performance.	Higher performance than Default Mode.

## 12.4 SwivelView Mode Limitations

The only limitation to using SwivelView mode on the S1D13705 is that split screen operation is not supported.

## 13 Power Save Modes

Two Power Save Modes have been incorporated into the S1D13705 to accommodate the need for power reduction in the hand-held devices market. These modes are enabled as follows:

*Table 13-1: Power Save Mode Selection*

Hardware Power Save	Software Power Save Bit 1	Software Power Save Bit 0	Mode
Not Configured or 0	0	0	Software Power Save Mode
Not Configured or 0	0	1	reserved
Not Configured or 0	1	0	reserved
Not Configured or 0	1	1	Normal Operation
Configured and 1	X	X	Hardware Power Save Mode

### 13.1 Software Power Save Mode

Software Power Save Mode saves power by powering down the panel and stopping display refresh accesses to the display buffer.

*Table 13-2: Software Power Save Mode Summary*

• Registers read/write accessible
• Memory read/write accessible
• Look-Up Table registers not accessible
• LCD outputs are forced low

### 13.2 Hardware Power Save Mode

Hardware Power Save Mode saves power by powering down the panel, stopping accesses to the display buffer and registers, and disabling the Host Bus Interface.

*Table 13-3: Hardware Power Save Mode Summary*

• Host Interface not accessible
• Memory read/write not accessible
• Look-Up Table registers not accessible
• LCD outputs are forced low



## 13.3 Power Save Mode Function Summary

Table 13-4: Power Save Mode Function Summary

	Hardware Power Save	Software Power Save	Normal
IO Access Possible?	No	Yes	Yes
Memory Access Possible?	No	Yes	Yes
Look-Up Table Registers Access Possible?	No	No	Yes
Sequence Controller Running?	No	No	Yes
Display Active?	No	No	Yes
LCDPWR	Inactive	Inactive	Active
FPDAT[11:0], FPSHIFT (see note)	Forced Low	Forced Low	Active
FPLINE, FPFRAME, DRDY	Forced Low	Forced Low	Active

### Note

When FPDAT[11:8] are designated as GPIO outputs, the output state prior to enabling the Power Save Mode is maintained. When FPDAT[11:8] are designated as GPIO inputs, unused inputs must be tied to either IO  $V_{DD}$  or GND - see Table 5.5 “LCD Interface Pin Mapping,” on page 23.

## 13.4 Panel Power Up/Down Sequence

After chip reset or when entering/exiting a power save mode, the Panel Interface signals follow a power on/off sequence shown below. This sequence is essential to prevent damage to the LCD panel.

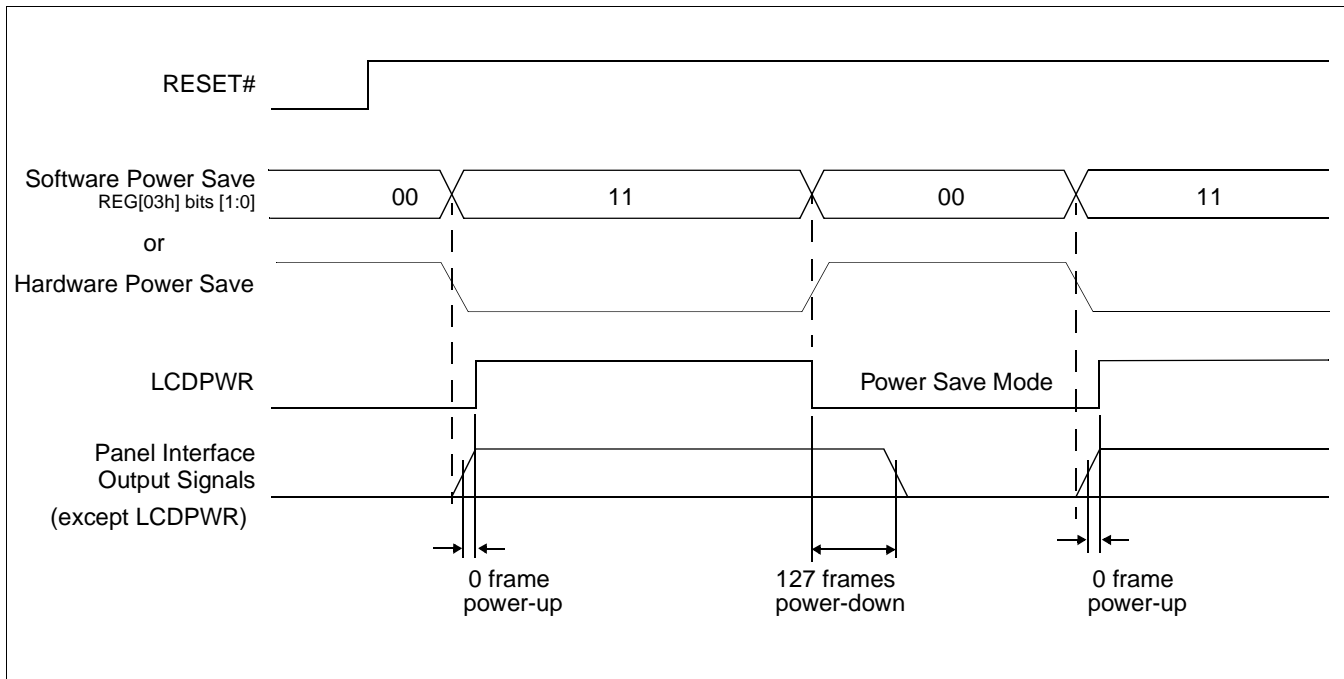

Figure 13-1: Panel On/Off Sequence

After chip reset, LCDPWR is inactive and the rest of the panel interface output signals are held “low”. Software initializes the chip (i.e. programs all registers except the Look-Up Table registers) and then programs REG[03h] bits [1:0] to 11b. This starts the power-up sequence as shown. The power-up/power-down sequence delay is 127 frames. The Look-Up Table registers may be programmed any time after REG[03h] bits[1:0] = 11b.

The power-up/power-down sequence also occurs when exiting/entering Software Power Save Mode.

## 13.5 Turning Off BCLK Between Accesses

BCLK may be turned off (held low) between accesses if the following rules are observed:

1. BCLK must be turned off/on in a glitch free manner
2. BCLK must continue for a period equal to  $[8T_{BCLK} + 12T_{MCLK}]$  after the end of the access (RDY# asserted or WAIT# deasserted).
3. BCLK must be present for at least one  $T_{BCLK}$  before the start of an access.

## 13.6 Clock Requirements

The following table shows what clock is required for which function in the S1D13705

*Table 13-5: S1D13705 Internal Clock Requirements*

Function	BCLK	CLKI
Register Read/Write	Is required during register accesses. BCLK can be shut down between accesses: allow eight BCLK pulses plus 12 MCLK pulses ( $8T_{BCLK} + 12T_{MCLK}$ ) after the last access before shutting BCLK off. Allow one BCLK pulse after starting up BCLK before the next access	Not Required
Memory Read/Write	Is required during memory accesses. BCLK can be shut down between accesses: allow eight BCLK pulses plus 12 MCLK pulses ( $8T_{BCLK} + 12T_{MCLK}$ ) after the last access before shutting BCLK off. Allow one BCLK pulse after starting up BCLK before the next access	Required
Look-Up Table Register Read/Write	Is required during LUT register accesses. BCLK can be shut down between accesses: allow eight BCLK pulses plus 12 MCLK pulses ( $8T_{BCLK} + 12T_{MCLK}$ ) after the last access before shutting BCLK off. Allow one BCLK pulse after starting up BCLK before the next access	Not Required
Software Power Save	Required	Can be stopped after 128 frames from entering Software Power Save, i.e. after REG[03h] bits 1-0 = 11
Hardware Power Save	Not Required	Can be stopped after 128 frames from entering Hardware Power Save

# 14 Mechanical Data

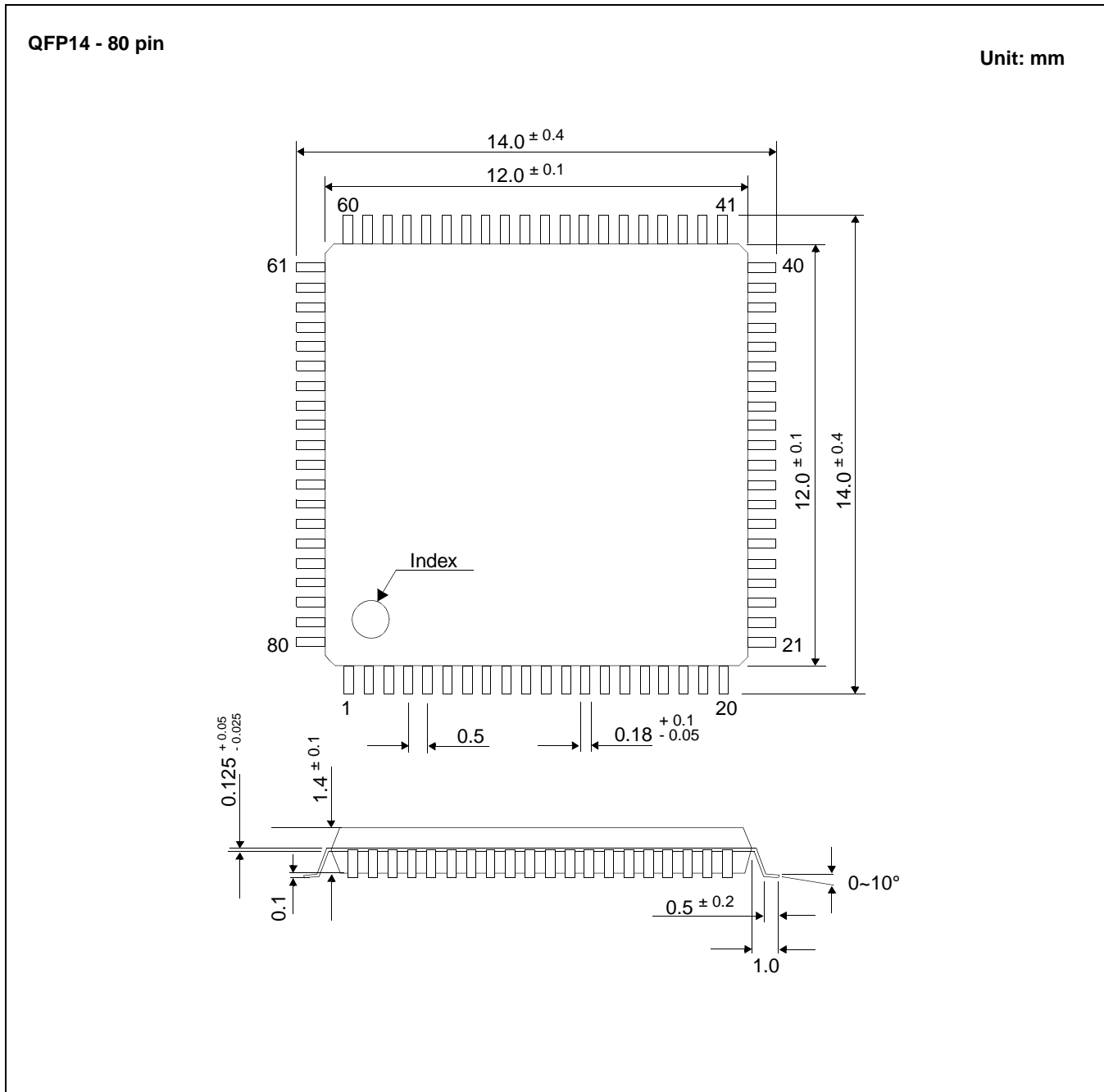

Figure 14-1: Mechanical Drawing QFP14

## 15 Sales and Technical Support

### Japan

Seiko Epson Corporation  
Electronic Devices Marketing Division  
421-8, Hino, Hino-shi  
Tokyo 191-8501, Japan  
Tel: 042-587-5812  
Fax: 042-587-5564  
<http://www.epson.co.jp>

### Hong Kong

Epson Hong Kong Ltd.  
20/F., Harbour Centre  
25 Harbour Road  
Wanchai, Hong Kong  
Tel: 2585-4600  
Fax: 2827-4346  
<http://www.epson.com.hk/>

### North America

Epson Electronics America, Inc.  
150 River Oaks Parkway  
San Jose, CA 95134, USA  
Tel: (408) 922-0200  
Fax: (408) 922-0238  
<http://www.eea.epson.com>

### Europe

Epson Europe Electronics GmbH  
Riesstrasse 15  
80992 Munich, Germany  
Tel: 089-14005-0  
Fax: 089-14005-110  
<http://www.epson-electronics.de>

### Taiwan

Epson Taiwan Technology  
& Trading Ltd.  
10F, No. 287  
Nanking East Road  
Sec. 3, Taipei, Taiwan  
Tel: 02-2717-7360  
Fax: 02-2712-9164  
<http://www.epson.com.tw/>

### Singapore

Epson Singapore Pte., Ltd.  
No. 1  
Temasek Avenue #36-00  
Millenia Tower  
Singapore, 039192  
Tel: 337-7911  
Fax: 334-2716  
<http://www.epson.com.sg/>

**THIS PAGE LEFT BLANK**



## **S1D13705 Embedded Memory LCD Controller**

# **Programming Notes and Examples**

**Document Number: X27A-G-002-03**

Copyright © 2001, 2002 Epson Research and Development, Inc. All Rights Reserved.

Information in this document is subject to change without notice. You may download and use this document, but only for your own use in evaluating Seiko Epson/EPSON products. You may not modify the document. Epson Research and Development, Inc. disclaims any representation that the contents of this document are accurate or current. The Programs/Technologies described in this document may contain material protected under U.S. and/or International Patent laws.

EPSON is a registered trademark of Seiko Epson Corporation. All other Trademarks are the property of their respective owners

---

**THIS PAGE LEFT BLANK**



# Table of Contents

<b>1</b>	<b>Introduction</b>	<b>7</b>
<b>2</b>	<b>Initialization</b>	<b>8</b>
2.1	Display Buffer Location	8
2.2	Register Values	8
2.3	Frame Rate Calculation	9
<b>3</b>	<b>Memory Models</b>	<b>12</b>
3.1	1 Bit-Per-Pixel (2 Colors/Gray Shades)	12
3.2	2 Bit-Per-Pixel (4 Colors/Gray Shades)	13
3.3	4 Bit-Per-Pixel (16 Colors/Gray Shades)	13
3.4	Eight Bit-Per-Pixel (256 Colors)	14
<b>4</b>	<b>Look-Up Table (LUT)</b>	<b>15</b>
4.1	Look-Up Table Registers	16
4.2	Look-Up Table Organization	17
4.2.1	Color Modes	17
4.2.2	Gray Shade Modes	22
<b>5</b>	<b>Advanced Techniques</b>	<b>25</b>
5.1	Virtual Display	25
5.1.1	Registers	26
5.1.2	Examples	26
5.2	Panning and Scrolling	27
5.2.1	Registers	28
5.2.2	Examples	29
5.3	Split Screen	31
5.3.1	Registers	32
5.3.2	Examples	34
<b>6</b>	<b>LCD Power Sequencing and Power Save Modes</b>	<b>35</b>
6.1	LCD Power Sequencing	35
6.2	Registers	35
6.3	LCD Enable/Disable	36
<b>7</b>	<b>Hardware Rotation</b>	<b>37</b>
7.1	Introduction To Hardware Rotation	37
7.2	Default Portrait Mode	37
7.3	Alternate Portrait Mode	39
7.4	Registers	40
7.5	Limitations	42
7.6	Examples	43

---

<b>8</b>	<b>Identifying the S1D13705</b>	<b>.47</b>
<b>9</b>	<b>Hardware Abstraction Layer (HAL)</b>	<b>.48</b>
9.1	Introduction	.48
9.2	Contents of the HAL_STRUCT	.48
9.3	Using the HAL library	.49
9.4	API for 13705HAL	.49
9.4.1	Initialization	51
9.4.2	General HAL Support	52
9.4.3	Advanced HAL Functions	55
9.4.4	Register / Memory Access	58
9.4.5	Power Save	60
9.4.6	Drawing	61
9.4.7	LUT Manipulation	62
9.5	Porting LIBSE to a new target platform	.64
9.5.1	Building the LIBSE library for SH3 target example	65
9.5.2	Building the HAL library for the target example	65
<b>10</b>	<b>Sample Code</b>	<b>.66</b>
10.1	Sample code using the S1D13705 HAL API	.66
10.2	Sample code without using the S1D13705 HAL API	.68
10.3	Header Files	.77

## List of Tables

Table 2-1: SID13705 Initialization Sequence . . . . .	9
Table 4-1: Recommended LUT Values for 1 Bpp Color Mode . . . . .	17
Table 4-2: Example LUT Values for 2 Bpp Color Mode . . . . .	18
Table 4-3: Suggested LUT Values to Simulate VGA Default 16 Color Palette . . . . .	19
Table 4-4: Suggested LUT Values to Simulate VGA Default 256 Color Palette . . . . .	20
Table 4-5: Recommended LUT Values for 1 Bpp Gray Shade . . . . .	22
Table 4-6: Suggested Values for 2 Bpp Gray Shade . . . . .	23
Table 4-7: Suggested LUT Values for 4 Bpp Gray Shade . . . . .	24
Table 5-1: Number of Pixels Panned Using Start Address . . . . .	28
Table 7-1: Default and Alternate Portrait Mode Comparison . . . . .	42
Table 9-1: HAL Functions . . . . .	49

## List of Figures

Figure 3-1: Pixel Storage for 1 Bpp (2 Colors/Gray Shades) in One Byte of Display Buffer . . . . .	12
Figure 3-2: Pixel Storage for 2 Bpp (4 Colors/Gray Shades) in One Byte of Display Buffer . . . . .	13
Figure 3-3: Pixel Storage for 4 Bpp (16 Colors/Gray Shades) in One Byte of Display Buffer . . . . .	13
Figure 3-4: Pixel Storage for 8 Bpp (256 Colors) in One Byte of Display Buffer . . . . .	14
Figure 5-1: Viewport Inside a Virtual Display . . . . .	25
Figure 5-2: 320x240 Single Panel For Split Screen . . . . .	31
Figure 7-1: Relationship Between the Default Mode Screen Image and the Image Refreshed by SID13705 . . . . .	38
Figure 7-2: Relationship Between the Alternate Mode Screen Image and the Image Refreshed by SID13705 . . . . .	39

**THIS PAGE LEFT BLANK**

---

# 1 Introduction

This guide demonstrates how to program the S1D13705 Embedded Memory Color LCD Controller. The guide presents the basic concepts of the LCD controller and provides methods to directly program the registers. It explains some of the advanced techniques used and the special features of the S1D13705.

The guide also introduces the Hardware Abstraction Layer (HAL), which is designed to make programming the S1D13705 as easy as possible. Future S1D1370x products will support the HAL allowing OEMs the ability to upgrade to future chips with relative ease.

## 2 Initialization

Prior to doing anything else with the S1D13705 the controller must be initialized. Initialization is the process of setting up the control registers to a known state in order to generate proper display signals.

### 2.1 Display Buffer Location

Before we can perform the initialization we have to know where to find the S1D13705 display memory and control registers.

The S1D13705 contains 80 kilobytes of internal display memory. External support logic must be employed to decode the starting address for this display memory in CPU address space. On the S5U13705B00x PC platform evaluation boards the address is usually fixed at F00000h. Alternatively the address can be set to D0000h.

The control registers are located by adding 1FFE0h (128 Kb less 32 bytes) to the base memory address. Thus, on the typical PC platform, we access control register 0 at address F1FFE0h. Control register 5 would be located at address F1FFE5, etc.

### 2.2 Register Values

This section describes the register settings and sequence of setting the registers. In addition to these setting the Look-Up Table must be programmed with appropriate colors. Look-Up Table setup is not covered here. See Section 4 on page 15 of this manual for Look-Up Table programming details.

The following initialization, presented in table form, shows the sequences and values to set the registers. The notes column comments the reason for the particular value being written.

This example writes to all the necessary registers. Initially, when the S1D13705 is powered up, all registers, unless noted otherwise in the specification, are set to zero. This example programs these registers to zero to establish a known state. In practice, it may be possible to write to only a subset of the registers.

The example initializes a S1D13705 to control a panel with the following specifications:

- 320x240 color single passive LCD panel at 70Hz.
- Color Format 2, 8-bit data interface.
- 8 bit-per-pixel (256 colors).
- 6 MHz input clock (CLKI).

Table 2-1: S1D13705 Initialization Sequence

Register	Value (hex)	Notes	See Also
[01]	0010 0011 (23)	Select a passive, Single, Color panel with an 8-bit data width	
[02]	1100 0000 (C0)	Select 8-bit per pixel color depth	
[03]	0000 0011 (03)	Select normal power operation	
[04]	0010 0111 (27)	Horizontal display size = $(\text{Reg}[04]+1)*8 = (39+1) * 8 = 320$ pixels	
[05]	1110 1111 (EF)	Vertical display size = $\text{Reg}[06][05] + 1$	
[06]	0000 0000 (00)	= $0000\ 0000\ 1110\ 1111 + 1 = 239 + 1 = 240$ lines	
[07]	0000 0000 (00)	FPLINE start position (only required for TFT configuration)	
[08]	0000 0000 (00)	Horizontal non-display period = $(\text{Reg}[08] + 4) * 8$ = $4 * 8 = 32$ pixels	Frame Rate Calculation
[09]	0000 0000 (00)	FPFRAME start position (only required for TFT configuration)	
[0A]	0000 0011 (03)	Vertical non-display period = $\text{REG}[0A] = 3$ lines	Frame Rate Calculation
[0B]	0000 0000 (00)	MOD rate is only required by some monochrome panels	
[0C]	0000 0000 (00)	Screen 1 Start Address - set to 0 for initialization	Split Screen on page 31
[0D]	0000 0000 (00)		
[0E]	0000 0000 (00)	Screen 2 Start Address - set to 0 for initialization	Split Screen on page 31
[0F]	0000 0000 (00)		
[10]	0000 0000 (00)	Screen 1 / Screen 2 Start Address MSB - set to 0	
[11]	0000 0000 (00)	Memory Address offset - not virtual setup - so set to 0	Virtual Display on page 25
[12]	1111 1111 (FF)	Set the vertical size to the maximum value.	Split Screen on page 31
[13]	0000 0011 (03)		
[15]		Leave the LUT alone for now	Look-Up Table (LUT) on page 15
[17]			
[18]	0000 0000 (00)	GPIO control and status registers - set to "0".	
[19]	0000 0000 (00)		
[1A]	0000 0000 (00)	Set the scratch pad bits to "0".	
[1B]	0000 0000 (00)	This is not portrait mode so set this register to "0".	Introduction To Hardware Rotation on page 37
[1C]	0000 0000 (00)	Line Byte Count is only required for portrait mode.	

## 2.3 Frame Rate Calculation

Frame rate specifies the number of complete frame which are drawn on the display in one second. Configuring a frame rate that is too high or too low adversely effects the quality of the displayed image.

System configuration imposes certain non-variable limitations. For instance the width and height of the display panel are fixed as is, typically, the input clock to the S1D13705. From the following formula it is evident that the two variables the programmer can use to adjust frame rate are horizontal and vertical non-display periods.

The following are the formulae for determining the frame rate of a panel. The formula for a single passive or TFT panel is calculated as follows:

$$\text{FrameRate} = \frac{\text{PCLK}}{(\text{HDP} + \text{HNDP}) \times (\text{VDP} + \text{VNDP})}$$

for a dual passive panel the formula is:

$$\text{FrameRate} = \frac{\text{PCLK}}{2 \times (\text{HDP} + \text{HNDP}) \times \left(\frac{\text{VDP}}{2} + \text{VNDP}\right)}$$

where: PCLK = Pixel clock (in Hz)  
 HDP = Horizontal Display Period (in pixels)  
 HNDP = Horizontal Non-Display Period (in pixels)  
 VDP = Vertical Display Period (in lines)  
 VNDP = Vertical Non-Display Period (in lines)

In addition to varying the HNDP and VNDP times we can also select divider values which will reduce CLKi to one half, one quarter up to one eighth of the CLKi value. The example below is a portion of a 'C' routine to calculate HNDP and VNDP from a desired frame rate.

```
for (int loop = 0; loop < 2; loop++)
{
    for (VNDP = 2; VNDP < 0x3F; VNDP += 3)
    {
        // Solve for HNDP
        HNDP = (PCLK / (FrameRate * (VDP + VNDP))) - HDP;
        if ((HNDP >= 32) && (HNDP <= 280))
        {
            // Solve for VNDP.
            VNDP = (PCLK / (FrameRate * (HDP + HNDP))) - VDP;
            // If we have satisfied VNDP then we're done.
            if ((VNDP >= 0) && (VNDP <= 0x3F))
                goto DoneCalc;
        }
    }
    // Divide ClkI and try again.
    // (Reg[02] allows us to dived CLKI by 2)
    PCLK /= 2;
}
// If we still can't hit the frame rate - throw an error.
if ((VNDP < 0) || (VNDP > 0x3F) || (HNDP < 32) || (HNDP > 280))
{
    sprintf("ERROR: Unable to set the desired frame rate.\n");
    exit(1);
}
```



This routine first performs a formula rearrangement so that HNBP or VNBP can be solved. Start with VNBP set to a small value. Loop increasing VNBP and solving the equation for HNBP until satisfactory HNBP and VNBP values are found. If no satisfactory values are found then divide CLKI and repeat the process. If a satisfactory frame rate still can't be reached - return an error.

**Note**

Most passive (STN) panels are tolerant of nearly any combination of HNBP and VNBP values, however panel specifications generally specify only a few lines of vertical non-display period. The S1D13705 is capable of generating a vertical non-display period of up to sixty-three lines. This amount of VNBP is far too great a non-display period and will likely degrade display quality. Similarly, setting a large HNBP value may cause a degrade in image quality.

If possible the system should be designed such that VNBP values of 7 or less lines and HNBP values of 20 or less characters can be selected.

## 3 Memory Models

The S1D13705 is capable of operating at four different color depths. For each color depth the data format is packed pixel. S1D13705 packed pixel modes can range from one byte containing eight adjacent pixels (1-bpp) to one byte containing just one pixel (8-bpp).

Packed pixel data may be envisioned as a stream of pixels. In this stream, pixels are packed in adjacent to each other. If a pixel requires four bits then it will be located in the four most significant bits of a byte. The pixel to the immediate right on the display will occupy the lower four bits of the same byte. The next two pixels to the immediate right are located in the following byte, etc.

### 3.1 1 Bit-Per-Pixel (2 Colors/Gray Shades)

1-bit pixels support two color/gray shades. In this memory format each byte of display buffer contains eight adjacent pixels. Setting or resetting any pixel requires reading the entire byte, masking out appropriate bits and, if necessary, setting bits to “1”.

When using a color panel the two colors are derived by indexing into positions 0 and 1 of the Look-Up Table. If the first two LUT elements are set to black (RGB = 0 0 0) and white (RGB = F F F) then each “0” bit of display memory will display as a black pixel and each “1” bit will display as a white pixel. The two LUT entries can be set to any desired colors, for instance red and green or cyan and yellow.

For monochrome panels the two displayed gray shades are generated by indexing into the first two elements of the green component of the Look-Up Table (LUT). Thus, by manipulating the green LUT components we can set either of the two gray shades to any of sixteen possible levels.

Bit 7	Bit 6	Bit 5	Bit 4	Bit 3	Bit 2	Bit 1	Bit 0
Pixel 0	Pixel 1	Pixel 2	Pixel 3	Pixel 4	Pixel 5	Pixel 6	Pixel 7

*Figure 3-1: Pixel Storage for 1 Bpp (2 Colors/Gray Shades) in One Byte of Display Buffer*

### 3.2 2 Bit-Per-Pixel (4 Colors/Gray Shades)

2-bit pixels support four color/gray shades. In this memory format each byte of display buffer contains four adjacent pixels. Setting or resetting any pixel requires reading the entire byte, masking out the appropriate bits and, if necessary, setting bits to “1”.

Color panels derive their four colors by indexing into positions 0 through 3 of the Look-Up Table. These four LUT entries can be set to any of the 4096 possible color combinations.

Monochrome panels derive four gray shades by indexing into the first four elements of the green component of the Look-Up Table. Any of the four LUT entries can be set to any of the sixteen possible gray shades.

Bit 7	Bit 6	Bit 5	Bit 4	Bit 3	Bit 2	Bit 1	Bit 0
Pixel 0 Bit 1	Pixel 0 Bit 0	Pixel 1 Bit 1	Pixel 1 Bit 0	Pixel 2 Bit 1	Pixel 2 Bit 0	Pixel 3 Bit 1	Pixel 3 Bit 0

Figure 3-2: Pixel Storage for 2 Bpp (4 Colors/Gray Shades) in One Byte of Display Buffer

### 3.3 4 Bit-Per-Pixel (16 Colors/Gray Shades)

Four bit pixels support 16 color/gray shades. In this memory format each byte of display buffer contains two adjacent pixels. Setting or resetting any pixel requires reading the entire byte, masking out the upper or lower nibble (4 bits) and setting the appropriate bits to “1”.

Color panels can display up to sixteen colors simultaneously. These sixteen colors are derived by indexing into the first sixteen elements of the Look-Up Table. Each of these colors may be selected from the 4096 possible available colors.

On a monochrome panel the gray shades are generated by indexing into the first sixteen green components of the LUT. Each of these sixteen possible gray shades can be adjusted to any of the sixteen possible gray shades. For instance, one could program the first eight green LUT entries to be 0 and the second green LUT entries to be FFh. This would result in nibble values of 0 through 7 displaying as black and nibble values 8 through 0Fh displaying as white.

Bit 7	Bit 6	Bit 5	Bit 4	Bit 3	Bit 2	Bit 1	Bit 0
Pixel 0 Bit 3	Pixel 0 Bit 2	Pixel 0 Bit 1	Pixel 0 Bit 0	Pixel 1 Bit 3	Pixel 1 Bit 2	Pixel 1 Bit 1	Pixel 1 Bit 0

Figure 3-3: Pixel Storage for 4 Bpp (16 Colors/Gray Shades) in One Byte of Display Buffer

### 3.4 Eight Bit-Per-Pixel (256 Colors)

In eight bit-per-pixel mode one byte of display buffer represents one pixel on the display. At this color depth the read-modify-write cycles, required by the lesser pixel depths, are eliminated.

When using a color panel, each byte of display memory acts as an index to one element of the LUT. The displayed color is arrived at by taking the display memory value as an index into the LUT.

Eight bit per pixel is not supported for monochrome display modes. The reason is that each element of the LUT supports a 4-bit (sixteen value) level for red, green and blue. In monochrome display modes on the green value is used to set the gray intensity. Thus we have sixteen possible grey values but, because of the color

Bit 7	Bit 6	Bit 5	Bit 4	Bit 3	Bit 2	Bit 1	Bit 0
Red bit 2	Red bit 1	Red bit 0	Green bit 2	Green bit 1	Green bit 0	Blue bit 1	Blue bit 0

*Figure 3-4: Pixel Storage for 8 Bpp (256 Colors) in One Byte of Display Buffer*

## 4 Look-Up Table (LUT)

This section is supplemental to the description of the Look-Up Table architecture found in the S1D13705 Hardware Functional Specification. Covered here is a review of the LUT registers, recommendations for the color and gray shade LUT values, and additional programming considerations for the LUT. Refer to the S1D13705 Hardware Functional Specification, document number X27A-A-001-xx for more detail.

The S1D13705 Look-Up Table consists of 256 indexed red/green/blue entries. Each entry is 4 bits wide. Two registers, REG[15h] and REG[17h], control access to the LUT.

Each Look-Up Table entry consists of a red, green, and blue component. Each component consisting of four bits, or sixteen intensity levels. Any Look-Up Table element can be selected from a palette of 4096 (16x16x16) colors.

In color display modes, pixel values are used as an index to an RGB value stored in the Look-Up Table. In monochrome modes, pixel values still index into the LUT, but only the green component is used to determine display intensity.

The selected color depth determines how many index positions are used for image display. For example at one bit-per-pixel (bpp) only index positions 0 and 1 of the Look-Up Table are used. At 4-bpp the first 16 index positions of the Look-Up Table are used and at 8-bpp all 256 Look-Up Table index positions are used.

The Look-Up Table mechanism itself consists of an index register and a data register. The index, or address, register determines which element of the Look-Up Table will be accessed. After setting the index the LUT may be read or written through the data register. The first data element read or written is the red component of the entry. Subsequent read/write operations access the green and then the blue elements of the Look-Up Table.

The S1D13705 LUT architecture is designed to provide a high degree of similarity in operation to a standard VGA RAMDAC. However, there are two considerations which must be kept in mind.

- The S1D13705 Look-Up Table has four bits (16 levels) of intensity per primary color. The standard VGA RAMDAC has six bits (64 levels). This four to one difference must be taken into consideration when converting from a VGA palette to a LUT palette. One suggestion is to divide the VGA intensity level by four to arrive at the LUT intensity.

However, most applications specify the red, green and blue components as eight bit intensities. To determine the appropriate S1D13705 Look-Up Table value we recommend using the four most significant bits.

## 4.1 Look-Up Table Registers

REG[15h] Look-Up Table Address Register							Read/Write
LUT Address Bit 7	LUT Address Bit 6	LUT Address Bit 5	LUT Address Bit 4	LUT Address Bit 3	LUT Address Bit 2	LUT Address Bit 1	LUT Address Bit 0

### LUT Address

The LUT address register selects which of the 256 LUT entries will be accessed. After three successive reads/writes to the data register this register is automatically incremented to point to the next address.

REG[17h] Look-Up Table Data Register							Read/Write
LUT Data Bit 3	LUT Data Bit 2	LUT Data Bit 1	LUT Data Bit 0	n/a	n/a	n/a	n/a

### LUT Data

This register is where the 4-bit red/green/blue data value is written/read. Immediately after setting the LUT index with register [15h] this register accesses the red element of the Look-Up Table. With each successive write/read the internal bank select is incremented. Thus the second access is from the green element and the third is from the blue element.

After the third access the LUT Address is incremented by one, then next access to this register will be the red element of the next Look-Up Table index.

## 4.2 Look-Up Table Organization

### 4.2.1 Color Modes

#### 1 bpp color

When the S1D13705 is configured for 1 bpp color mode, the LUT is limited to selecting colors from the first two entries. The two LUT entries can be any two RGB values but are typically set to black-and-white.

Each byte in the display buffer contains eight adjacent pixels. If a bit has a value of “0” then the color in LUT 0 index is displayed. A bit value of “1” results in the color in LUT 1 index being displayed.

The following table shows the recommended values for obtaining a black-and-white mode while in 1 bpp on a color panel.

*Table 4-1: Recommended LUT Values for 1 Bpp Color Mode*

Index	Red	Green	Blue
00	00	00	00
01	F0	F0	F0
02	00	00	00
...	00	00	00
FF	00	00	00
	unused entries		

## 2 bpp color

When the S1D13705 is configured for 2 bpp color mode, the displayed colors are selected from the first four entries of the Look-Up Table. The LUT entries may be set to any of the 4096 possible colors.

Each byte in the display buffer contains four adjacent pixels. If a bit combination has a value of “00” then the color in LUT index 0 is displayed. A bit value of “01” results in the color in LUT index 1 being displayed. Likewise the bit combination of “10” displays from the third LUT entry and “11” displays a color from the fourth LUT entry.

The following table shows the example values for 2 bit-per-pixel display mode.

*Table 4-2: Example LUT Values for 2 Bpp Color Mode*

Index	Red	Green	Blue
00	00	00	00
01	70	70	70
02	A0	A0	A0
03	F0	F0	F0
04	00	00	00
...	00	00	00
FF	00	00	00

	indicates unused entries
--	--------------------------



### 4 bpp color

When the S1D13705 is configured for 4 bpp color mode, the displayed colors are selected from the first sixteen entries of the Look-Up Table. The LUT entries may be set to any of the 4096 possible colors.

Each byte in the display buffer contains two adjacent pixels. If a nibble has a value of “0000” then the color in LUT index 0 is displayed. A nibble value of “0001” results in the color in LUT index 1 being displayed. The pattern continues to the nibble pattern of “1111” which results in the sixteenth color of the Look-Up Table being displayed.

The following table shows the example values for 4 bit-per-pixel display mode. These colors simulate the colors used by the sixteen color modes of a VGA.

*Table 4-3: Suggested LUT Values to Simulate VGA Default 16 Color Palette*

Index	Red	Green	Blue
00	00	00	00
01	00	00	A0
02	00	A0	00
03	00	A0	A0
04	A0	00	00
05	A0	00	A0
06	A0	A0	00
07	A0	A0	A0
08	00	00	00
09	00	00	F0
0A	00	F0	00
0B	00	F0	F0
0C	F0	00	00
0D	F0	00	F0
0E	F0	F0	00
0F	F0	F0	F0
10	00	00	00
...	00	00	00
FF	00	00	00

	indicates unused entries
--	--------------------------

## 8 bpp color

When the S1D13705 is configured for 8 bpp color mode the entire Look-Up Table is used to display images. Each of the LUT entries may be set to any of the 4096 possible colors.

Each byte in the display buffer represents one pixels. The byte value is used directly as an index into one of the 256 LUT entries. A display memory byte with a value of 00h will display the color contained in the first Look-Up Table entry while a display memory byte of FFh will display a color formed by the two hundred and fifty sixth Look-Up Table entry.

The following table depicts LUT values which approximate the VGA default 256 color palette.

*Table 4-4: Suggested LUT Values to Simulate VGA Default 256 Color Palette*

Index	R	G	B	Index	R	G	B	Index	R	G	B	Index	R	G	B
00	00	00	00	40	F0	70	70	80	30	30	70	C0	00	40	00
01	00	00	A0	41	F0	90	70	81	40	30	70	C1	00	40	10
02	00	A0	00	42	F0	B0	70	82	50	30	70	C2	00	40	20
03	00	A0	A0	43	F0	D0	70	83	60	30	70	C3	00	40	30
04	A0	00	00	44	F0	F0	70	84	70	30	70	C4	00	40	40
05	A0	00	A0	45	D0	F0	70	85	70	30	60	C5	00	30	40
06	A0	50	00	46	B0	F0	70	86	70	30	50	C6	00	20	40
07	A0	A0	A0	47	90	F0	70	87	70	30	40	C7	00	10	40
08	50	50	50	48	70	F0	70	88	70	30	30	C8	20	20	40
09	50	50	F0	49	70	F0	90	89	70	40	30	C9	20	20	40
0A	50	F0	50	4A	70	F0	B0	8A	70	50	30	CA	30	20	40
0B	50	F0	F0	4B	70	F0	D0	8B	70	60	30	CB	30	20	40
0C	F0	50	50	4C	70	F0	F0	8C	70	70	30	CC	40	20	40
0D	F0	50	F0	4D	70	D0	F0	8D	60	70	30	CD	40	20	30
0E	F0	F0	50	4E	70	B0	F0	8E	50	70	30	CE	40	20	30
0F	F0	F0	F0	4F	70	90	F0	8F	40	70	30	CF	40	20	20
10	00	00	00	50	B0	B0	F0	90	30	70	30	D0	40	20	20
11	10	10	10	51	C0	B0	F0	91	30	70	40	D1	40	20	20
12	20	20	20	52	D0	B0	F0	92	30	70	50	D2	40	30	20
13	20	20	20	53	E0	B0	F0	93	30	70	60	D3	40	30	20
14	30	30	30	54	F0	B0	F0	94	30	70	70	D4	40	40	20
15	40	40	40	55	F0	B0	E0	95	30	60	70	D5	30	40	20
16	50	50	50	56	F0	B0	D0	96	30	50	70	D6	30	40	20
17	60	60	60	57	F0	B0	C0	97	30	40	70	D7	20	40	20
18	70	70	70	58	F0	B0	B0	98	50	50	70	D8	20	40	20
19	80	80	80	59	F0	C0	B0	99	50	50	70	D9	20	40	20
1A	90	90	90	5A	F0	D0	B0	9A	60	50	70	DA	20	40	30
1B	A0	A0	A0	5B	F0	E0	B0	9B	60	50	70	DB	20	40	30

Table 4-4: Suggested LUT Values to Simulate VGA Default 256 Color Palette (Continued)

Index	R	G	B	Index	R	G	B	Index	R	G	B	Index	R	G	B
1C	B0	B0	B0	5C	F0	F0	B0	9C	70	50	70	DC	20	40	40
1D	C0	C0	C0	5D	E0	F0	B0	9D	70	50	60	DD	20	30	40
1E	E0	E0	E0	5E	D0	F0	B0	9E	70	50	60	DE	20	30	40
1F	F0	F0	F0	5F	C0	F0	B0	9F	70	50	50	DF	20	20	40
20	00	00	F0	60	B0	F0	B0	A0	70	50	50	E0	20	20	40
21	40	00	F0	61	B0	F0	C0	A1	70	50	50	E1	30	20	40
22	70	00	F0	62	B0	F0	D0	A2	70	60	50	E2	30	20	40
23	B0	00	F0	63	B0	F0	E0	A3	70	60	50	E3	30	20	40
24	F0	00	F0	64	B0	F0	F0	A4	70	70	50	E4	40	20	40
25	F0	00	B0	65	B0	E0	F0	A5	60	70	50	E5	40	20	30
26	F0	00	70	66	B0	D0	F0	A6	60	70	50	E6	40	20	30
27	F0	00	40	67	B0	C0	F0	A7	50	70	50	E7	40	20	30
28	F0	00	00	68	00	00	70	A8	50	70	50	E8	40	20	20
29	F0	40	00	69	10	00	70	A9	50	70	50	E9	40	30	20
2A	F0	70	00	6A	30	00	70	AA	50	70	60	EA	40	30	20
2B	F0	B0	00	6B	50	00	70	AB	50	70	60	EB	40	30	20
2C	F0	F0	00	6C	70	00	70	AC	50	70	70	EC	40	40	20
2D	B0	F0	00	6D	70	00	50	AD	50	60	70	ED	30	40	20
2E	70	F0	00	6E	70	00	30	AE	50	60	70	EE	30	40	20
2F	40	F0	00	6F	70	00	10	AF	50	50	70	EF	30	40	20
30	00	F0	00	70	70	00	00	B0	00	00	40	F0	20	40	20
31	00	F0	40	71	70	10	00	B1	10	00	40	F1	20	40	30
32	00	F0	70	72	70	30	00	B2	20	00	40	F2	20	40	30
33	00	F0	B0	73	70	50	00	B3	30	00	40	F3	20	40	30
34	00	F0	F0	74	70	70	00	B4	40	00	40	F4	20	40	40
35	00	B0	F0	75	50	70	00	B5	40	00	30	F5	20	30	40
36	00	70	F0	76	30	70	00	B6	40	00	20	F6	20	30	40
37	00	40	F0	77	10	70	00	B7	40	00	10	F7	20	30	40
38	70	70	F0	78	00	70	00	B8	40	00	00	F8	00	00	00
39	90	70	F0	79	00	70	10	B9	40	10	00	F9	00	00	00
3A	B0	70	F0	7A	00	70	30	BA	40	20	00	FA	00	00	00
3B	D0	70	F0	7B	00	70	50	BB	40	30	00	FB	00	00	00
3C	F0	70	F0	7C	00	70	70	BC	40	40	00	FC	00	00	00
3D	F0	70	D0	7D	00	50	70	BD	30	40	00	FD	00	00	00
3E	F0	70	B0	7E	00	30	70	BE	20	40	00	FE	00	00	00
3F	F0	70	90	7F	00	10	70	BF	10	40	00	FF	00	00	00

## 4.2.2 Gray Shade Modes

Gray shade modes are monochrome display modes. Monochrome display modes use the Look-Up Table in a very similar fashion to the color modes. This most significant difference is that the monochrome display modes use only the intensity of the green element of the Look-Up Table to form the gray level.

One side effect of using only green for intensity selection is that in gray shade modes there are only sixteen possible intensities. 8 bit-per-pixel is not supported for gray shade modes.

### 1 bpp gray shade

When the S1D13705 is configured for 1 bpp gray shade mode, the LUT is limited to selecting colors from the first two green entries. The two LUT entries can be set to any of sixteen possible intensities. Typically they would be set to 0h (black) and Fh (white).

Each byte in the display buffer contains eight adjacent pixels. If a bit has a value of “0” then the color in the green LUT 0 index is displayed. A bit value of “1” results in the color in green LUT 1 index being displayed.

The following table shows the recommended values 1 bpp gray shade display mode.

*Table 4-5: Recommended LUT Values for 1 Bpp Gray Shade*

Address	Red	Green	Blue
00	00	00	00
01	00	F0	00
02	00	00	00
...	00	00	00
FF	00	00	00
	unused entries		

### 2 bpp gray shade

When the S1D13705 is configured for 2 bpp gray shade, the displayed colors are selected from the first four green entries in the Look-Up Table. The remaining entries of the LUT are unused. Each of the four entries can be set to any of the sixteen possible colors.

Each byte in the display buffer contains four adjacent pixels. If a bit combination has a value of “00” then the intensity in the green LUT index 0 is displayed. A bit value of “01” results in the intensity represented by the green in LUT index 1 being displayed. Likewise the bit combination of “10” displays from the third LUT entry and “11” displays a from the fourth LUT entry.

The following table shows the example values for 2 bit-per-pixel display mode.

*Table 4-6: Suggested Values for 2 Bpp Gray Shade*

<b>Index</b>	<b>Red</b>	<b>Green</b>	<b>Blue</b>
0	00	00	00
1	00	50	00
2	00	A0	00
3	00	F0	00
4	00	00	00
...	00	00	00
FF	00	00	00

	indicates unused entries
--	--------------------------

#### 4 bpp gray shade

When the S1D13705 is configured for 4 bpp gray shade mode the displayed colors are selected from the green values of the first sixteen entries of the Look-Up Table. Each of the sixteen entries can be set to any of the sixteen possible intensity levels.

Each byte in the display buffer contains two adjacent pixels. If a nibble pattern is “0000” then the green intensity of LUT index 0 is displayed. A nibble value of “0001” results in the green intensity in LUT index 1 being displayed. The pattern continues to the nibble pattern of “1111” which results in the sixteenth intensity of Look-Up Table being displayed.

The following table shows the example values for 4 bit-per-pixel display mode.

*Table 4-7: Suggested LUT Values for 4 Bpp Gray Shade*

Index	Red	Green	Blue
00	00	00	00
01	00	10	00
02	00	20	00
03	00	30	00
04	00	40	00
05	00	50	00
06	00	60	00
07	00	70	00
08	00	80	00
09	00	90	00
0A	00	A0	00
0B	00	B0	00
0C	00	C0	00
0D	00	D0	00
0E	00	E0	00
0F	00	F0	00
10	00	00	00
...	00	00	00
FF	00	00	00

	indicates unused entries
--	--------------------------

## 5 Advanced Techniques

This section contains programming suggestions for the following:

- virtual display
- panning and scrolling
- split screen display

### 5.1 Virtual Display

Virtual display refers to the situation where the image to be viewed is larger than the physical display. The difference can be in the horizontal, vertical or both dimensions. To view the image, the display is used as a window into the display buffer. At any given time only a portion of the image is visible. Panning and scrolling are used to view the full image.

The Memory Address Offset register determines the number of horizontal pixels in the virtual image. The offset register can be used to specify from 0 to 255 additional words for each scan line. At 1 bpp, 255 words span an additional 4,080 pixels. At 8 bpp, 255 words span an additional 510 pixels.

The maximum vertical size of the virtual image is the result of dividing 81920 bytes of display memory by the number of bytes on each line (i.e. at 1 bpp with a 320x240 panel set for a virtual width of 640x480 there is enough memory for 1024 lines).

Figure 5-1: “Viewport Inside a Virtual Display,” depicts a typical use of a virtual display. The display panel is 320x240 pixels, an image of 640x480 pixels can be viewed by navigating a 320x240 pixel viewport around the image using panning and scrolling.

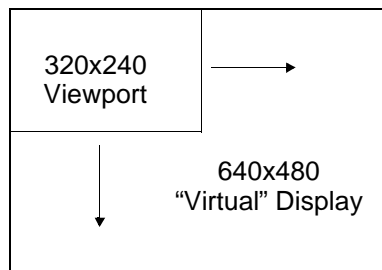

*Figure 5-1: Viewport Inside a Virtual Display*

## 5.1.1 Registers

REG[11h] Memory Address Offset Register							
Memory Address Offset Bit 7	Memory Address Offset Bit 6	Memory Address Offset Bit 5	Memory Address Offset Bit 4	Memory Address Offset Bit 3	Memory Address Offset Bit 2	Memory Address Offset Bit 1	Memory Address Offset Bit 0

### Memory Address Offset Register

REG[11h] forms an 8-bit value called the Memory Address Offset. This offset is the number of additional words on each line of the display. If the offset is set to zero there is no virtual width.

#### Note

This value does not represent the number of words to be shown on the display. The display width is set in the Horizontal Display Width register.

## 5.1.2 Examples

**Example 1: In this example we go through the calculations to display a 640x480 image on a 320x240 panel at 2 bpp.**

Step 1: Calculate the number of pixels per word for this color depth.

At 2 bpp each byte is comprised of 4 pixels, therefore each word contains 8 pixels.

$$\text{pixels\_per\_word} = 16 / \text{bpp} = 16 / 2 = 8$$

Step 2: Calculate the Memory Address Offset register value

We require a total of 640 pixels. The horizontal display register will account for 320 pixels, this leaves 320 pixels for the Memory Address Offset register to account for.

$$\text{offset} = \text{pixels} / \text{pixels\_per\_word} = 320 / 8 = 40 = 28\text{h}$$

The Memory Address Offset register, REG[11h], will have to be set to 28h to satisfy the above condition.



***Example 2: From the above, what is the maximum number of lines our image can contain?***

Step 1: Calculate the number of bytes on each line.

$$\text{bytes\_per\_line} = \text{pixels\_per\_line} / \text{pixels\_per\_byte} = 640 / 4 = 160$$

Each line of the display requires 160 bytes.

Step 2: Calculate the number of lines the S1D13705 is capable of.

$$\text{total\_lines} = \text{memory} / \text{bytes\_per\_line} = 81920 / 160 = 512$$

We can display a maximum of 512 lines. Our example image requires 480 lines so this example can be done.

## 5.2 Panning and Scrolling

Panning and scrolling describe the operation of moving a physical display viewport about a virtual image in order to view the entire image a portion at time. For example, after setting up the previous example (virtual display) and drawing an image into it we would only be able to view one quarter of the image. Panning and scrolling are used to reveal the rest of the image.

Panning describes the horizontal (side to side) motion of the viewport. When panning to the right the image in the viewport appears to slide to the left. When panning to the left the image to appears to slide to the right. Scrolling describes the vertical (up and down) motion of the viewport. Scrolling down causes the image to appear to slide up and scrolling up causes the image to appear to slide down.

Both panning and scrolling are performed by modifying the start address register. The start address registers in the S1D13705 are a word offset to the data to be displayed in the top left corner of a frame. Changing the start address by one means a change on the display of the number of pixels in one word. The number of pixels in word varies according to the color depth. At 1 bit-per-pixel a word contains sixteen pixels. At 2 bit-per-pixel there are eight pixels, at 4 bit-per-pixel there are four pixels and at 8 bit-per-pixel there is two pixels in each word. The number of pixels in each word represent the finest step we can pan to the left or right.

When portrait mode (see Hardware Rotation on page 37) is enabled the start address registers become offsets to bytes. In this mode the step rate for the start address registers if halved making for smoother panning.

## 5.2.1 Registers

REG[0Ch] Screen 1 Display Start Address 0 (LSB)							
Start Addr Bit 7	Start Addr Bit 6	Start Addr Bit 5	Start Addr Bit 4	Start Addr Bit 3	Start Addr Bit 2	Start Addr Bit 1	Start Addr Bit 0

REG[0Dh] Screen 1 Display Start Address 1 (MSB)							
Start Addr Bit 15	Start Addr Bit 14	Start Addr Bit 13	Start Addr Bit 12	Start Addr Bit 11	Start Addr Bit 10	Start Addr Bit 9	Start Addr Bit 8

REG[10h] Screen 1 Display Start Address 2 (MSB)							
n/a	n/a	n/a	n/a	n/a	n/a	n/a	Start Addr Bit 16

### Screen 1 Start Address Registers

These three registers form the seventeen bit screen 1 start address. Screen 1 is displayed starting at the top left corner of the display.

In landscape mode these registers form the word offset to the first byte in display memory to be displayed in the upper left corner of the screen. Changing these registers by one will shift the display image 2 to 16 pixels, depending on the current color depth.

In portrait mode these registers form the offset to the display memory byte where screen 1 will start displaying. Changing these registers in portrait mode will result in a shift of 1 to 8 pixels depending on the color depth.

Refer to Table 5-1: “Number of Pixels Panned Using Start Address” to see the minimum number of pixels affected by a change of one to these registers

*Table 5-1: Number of Pixels Panned Using Start Address*

Color Depth (bpp)	Pixels per Word	Landscape Mode Number of Pixels Panned	Pixels Per Byte	Portrait Mode Number of Pixels Panned
1	16	16	8	8
2	8	8	4	4
4	4	4	2	2
8	2	2	1	1

## 5.2.2 Examples

For the following examples we base our calculations on a 4 bit-per-pixel image displayed on a 256w x 64h panel. We have set up a virtual size of 320w x 240h. Width is greater than height so we are in landscape display mode. Refer to Section 2, “Initialization” on page 8 and Section 5.1, “Virtual Display” on page 25 for assistance with these settings.

These examples are shown using a C-like syntax.

### **Example 3: Panning (Right and Left)**

To pan to the right increase the start address value by one. To pan to the left decrease the start address value. Keep in mind that, with the exception of 8 bit-per-pixel portrait display mode, the display will jump by more than one pixel as a result of changing the start address registers.

Panning to the right.

```
StartWord = GetStartAddress();
StartWord ++;
SetStartAddress(StartWord);
```

Panning to the left.

```
StartWord = GetStartAddress();
StartWord --;
if (StartWord < 0)
    StartWord = 0;
SetStartAddress(StartWord);
```

The routine `GetStartAddress()` is one which will read the start address registers and return the start address as a long value. It would be written similar to:

```
long GetStartAddress()
{
    return ((REG[10] & 1) * 65536) + (REG[0D] * 256) + (REG[0C]);
}
```

The routine `SetStartAddress()` break up its long integer argument into three register values and store the values.

```
void SetStartAddress(long SA)
{
    REG[0C] = SA & 0xFF;
    REG[0D] = (SA >> 8) & 0xFF;
    REG[10] = (SA >> 16) & 0xFF;
}
```

In this example code the notation `REG[]` refers to whatever mechanism is employed to read/write the registers.

**Example 4: Scrolling (Up and Down)**

To scroll down, increase the value in the Screen 1 Display Start Address Register by the number of words in one *virtual* scan line. To scroll up, decrease the value in the Screen 1 Display Start Address Register by the number of words in one *virtual* scan line. A virtual scan line includes both the number of bytes required by the physical display and any extra bytes that may be being used for creating a virtual width on the display.

The previous dimensions are still in effect for this example (i.e. 320w x 240h virtual size, 256h x 64w physical size at 4 bpp)

Step 1: Determine the number of words in one virtual scanline.

$$\text{bytes\_per\_line} = \text{pixels\_per\_line} / \text{pixels\_per\_byte} = 320 / 2 = 160$$
$$\text{words\_per\_line} = \text{bytes\_per\_line} / 2 = 160 / 2 = 80$$

Step 2: Scroll up or down

To scroll up.

```
StartWord = GetStartAddress();
StartWord -= words_per_line;
if (StartWord < 0)
    StartWord = 0;
SetStartAddress(StartWord);
```

To scroll down.

```
StartWord = GetStartAddress();
StartWord += words_per_line;
SetStartAddress(StartWord);

}
```

### 5.3 Split Screen

Occasionally the need arises to display two different but related images. Take, for example, a game where the main play area requires rapid updates and game status, displayed at the bottom of the screen, requires infrequent updates.

The Split Screen feature of the S1D13705 allows a programmer to setup a display in such a manor. When correctly configured the programmer has only to update the main area on a regular basis. Occasionally, as the need arises, the secondary area is updated.

The figure below illustrates how a 320x240 panel may be configured to have one image displaying from scan line 0 to scan line 199 and image 2 displaying from scan line 200 to scan line 239. Although this example picks specific values, the split between image 1 and image 2 may occur at any line of the display.

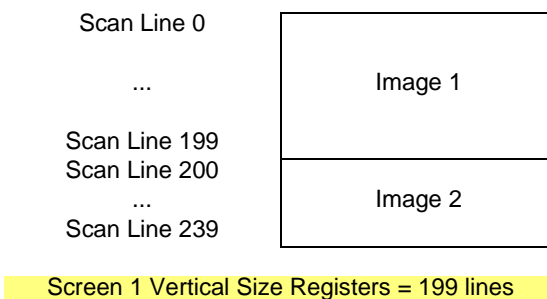

*Figure 5-2: 320x240 Single Panel For Split Screen*

In split screen operation “Image 1” is taken from the display memory location pointed to by the Screen 1 Start Address registers and is always located at the top of the screen. “Image 2” is taken from the display memory location pointed to by the Screen 2 Start Address registers. The line where “Image 1” end and “Image 2” begins is determined by the Screen 1 Vertical Size register.

### 5.3.1 Registers

Split screen operation is performed primarily by manipulating three register sets. Screen 1 Start Address and Screen 2 Start Address determine from where in display memory the first and second images will be taken from. The Vertical Size registers determine how many lines Screen 1 will use. The following is a description of the registers used to do split screen.

REG[12] Screen 1 Vertical Size (LSB)							
Bit 7	Bit 6	Bit 5	Bit 4	Bit 3	Bit 2	Bit 1	Bit 0

REG[13] Screen 1 Vertical Size (MSB)							
n/a	n/a	n/a	n/a	n/a	n/a	Bit 9	Bit 8

#### Screen 1 Vertical Size

These two registers form a ten bit value which determines the size of screen 1. When the vertical size is equal to or greater than the physical number of lines being displayed there is no visible effect on the display. When the vertical size value is less than the number of physical display lines, operation is like this:

1. From the beginning of a frame to the number of lines indicated by vertical size the display data will come from the memory area pointed to by the Screen 1 Display Start Address.
2. After *vertical size* lines have been displayed the system will begin displaying data from the memory area pointed to by Screen 2 Display Start Address.

One thing that must be pointed out here is that Screen 1 memory is **always** displayed at the top of the screen followed by screen 2 memory. This relationship holds true regardless of where in display memory Screen 1 Start Address and Screen 2 Start Address are pointing. For instance, Screen 2 Start Address may point to offset zero of display memory while Screen 1 Start Address points to a location several thousand bytes higher. Screen 1 will still be shown first on the display. While not particularly useful, it is even possible to set screen 1 and screen 2 to the same address.

REG[0Eh] Screen 2 Display Start Address 0 (LSB)							
Start Addr Bit 7	Start Addr Bit 6	Start Addr Bit 5	Start Addr Bit 4	Start Addr Bit 3	Start Addr Bit 2	Start Addr Bit 1	Start Addr Bit 0

REG[0Fh] Screen 2 Display Start Address 1 (MSB)							
Start Addr Bit 15	Start Addr Bit 14	Start Addr Bit 13	Start Addr Bit 12	Start Addr Bit 11	Start Addr Bit 10	Start Addr Bit 9	Start Addr Bit 8

### Screen 2 Start Address Registers

These three registers form the seventeen bit Screen 2 Start Address. Screen 2 is always displayed immediately following the screen 1 data and will begin at the left-most pixel on a line. Keep in mind that if the Screen 1 Vertical Size is equal to or greater than the physical display then Screen 2 will not be shown.

In landscape mode these registers form the word offset to the first byte in display memory to be displayed. Changing these registers by one will shift the display image 2 to 16 pixels, depending on the current color depth.

The S1D13705 does not support split screen operation in portrait mode. Screen 2 will never be used if portrait mode is selected.

Refer to Table 5-1: “Number of Pixels Panned Using Start Address” to see the minimum number of pixels affected by a change of one to these registers

Screen 1 Start Address registers, REG[0C], REG[0D] and REG[10] are discussed in Section 5.2.1 on page 28

## 5.3.2 Examples

**Example 5: Display 200 scanlines of image 1 and 40 scanlines of image 2. Image 2 is located first (offset 0) in the display buffer followed immediately by image 1. Assume a 320x240 display and a color depth of 4 bpp.**

1. Calculate the Screen 1 Vertical Size register values.

$$\text{vertical\_size} = 200 = \text{C8h}$$

Write the Vertical Size LSB, REG[12h], with C8h and Vertical Size MSB, REG[13h], with a 00h.

2. Calculate the Screen 1 Start Word Address register values.

Screen 2 is located first in display memory, therefore we must calculate the number of bytes taken up by the screen 2 data.

$$\text{bytes\_per\_line} = \text{pixels\_per\_line} / \text{pixels\_per\_byte} = 320 / 2 = 160$$

$$\text{total bytes} = \text{bytes\_per\_line} \times \text{lines} = 160 \times 40 = 6400.$$

Screen 2 requires 6400 bytes (0 to 6399) therefore the start address offset for screen 1 must be 6400 bytes. (6400 bytes = 3200 words = C80h words)

Set the Screen 1 Start Word Address MSB, REG[0Dh], to 0Ch and the Screen 1 Start Word Address LSB, REG[0Ch], to 80h.

3. Calculate the Screen 2 Start Word Address register values.

Screen 2 display data is coming from the very beginning of the display buffer. All there is to do here is ensure that both the LSB and MSB of the Screen 2 Start Word Address registers are set to zero.



## 6 LCD Power Sequencing and Power Save Modes

### 6.1 LCD Power Sequencing

Correct power sequencing is required to prevent long term damage to LCD panels and to avoid unsightly “lines” during power-up and power-down. Power Sequencing allows the LCD power supply to discharge prior to shutting down the LCD logic signals.

Proper LCD power sequencing dictates there must be a time delay between the LCD power being disabled and the LCD signals being shut down. During power-up the LCD signals must be active prior to or when power is applied to the LCD. The time intervals vary depending on the power supply design.

The S1D13705 performs automatic power sequencing in response to both software power save (REG[03h]) or in response to a hardware power save. One frame after a power save mode is set, the S1D13705 disables LCD power, and the LCD logic signals continue for one hundred and twenty seven frames allowing the LCD power supply to completely discharge. For most applications the internal power sequencing is the appropriate choice.

There may be situations where the internal time delay is insufficient to discharge the LCD power supply before the LCD signals are shut down, or the delay is too long and the designer wishes to shorten it. This section details the sequences to manually power-up and power-down the LCD interface.

### 6.2 Registers

REG[03h] Mode Register 2							
				LCDPWR Override	Hardware Power Save Enable	Software Power Save bit 1	Software Power Save bit 0

The LCD Power (LCDPWR) Override bit forces LCD power inactive one frame after being toggled. As long as this bit is “1” LCD power will be disabled.

The Hardware Power Save Enable bit must be set in order to activate hardware power save through GPIO0.

The Software Power Save bits set and reset the software power save mode. These bits are set to “11” for normal operation and set to “00” for power save mode.

LCD logic signals to the display panel are active for 128 frames after setting either hardware or software power save modes. Power sequencing override is performed by setting the LCDPWR Override bit some time before setting a power save mode for power off sequences. During power on sequences the power save mode is reset some time before the LCDPWR Override is reset resulting in the LCD logic signals being active before power is applied to the panel.

## 6.3 LCD Enable/Disable

The descriptions below cover manually powering the LCD panel up and down. Use the sequences described in this section if the power supply connected to the panel requires more than 127 frames to discharge on power-down, or if the panel requires starting the LCD logic well in advance of enabling LCD power. Currently there are no known circumstances where the LCD logic must be active well in advance of LCD power.

### Note

If 127 frame period is too long, blank the display, then reprogram the Horizontal and Vertical sizes to produce a shorter frame period before using these methods.

### Power On/Enable Sequence

The following is a sequence for manually powering-up an LCD panel if LCD power had to be applied later than LCD logic.

1. Set REG[03h] bit 3 (LCDPWR Override) to “1”. This ensures that LCD power will be held disabled.
2. Enable LCD logic. This is done by either setting the GPIO0 pin low to disable hardware power save mode and/or by setting REG[03h] bits 1-0 to “11” to disable software power save.
3. Count “x” Vertical Non-Display Periods (OPTIONAL).  
“x” corresponds to the length of time LCD logic must be enabled before LCD power-up, converted to the equivalent vertical non-display periods. For example, at 72 HZ counting 36 non-display periods results in a one half second delay.
4. Set REG[03h] bit 3 to “0” to enable LCD Power.

### Power Off/Disable Sequence

The following is a sequence for manually powering-down an LCD panel. These steps would be used if the power supply discharge requirements are larger than the default 127 frames.

1. Set REG[03h] bit 3 (LCDPWR Override) to “1” which will disable LCD Power.
2. Count “x” Vertical Non-Display Periods.  
“x” corresponds to the power supply discharge time converted to the equivalent vertical non-display periods. (see the previous example)
3. Disable the LCD logic by setting the software power save in REG[03h] or setting hardware power save via GPIO0. Keep in mind that after setting the power save mode there will be 127 frames before the LCD logic signals are disabled.

## 7 Hardware Rotation

### 7.1 Introduction To Hardware Rotation

Many of today's applications use the LCD panel in a portrait orientation (typically LCD panels are landscape oriented). In this case it becomes necessary to "rotate" the displayed image. This rotation can be done by software at the expense of performance or, as with the S1D13705, it can be done by hardware with no performance penalty.

This discussion of display rotation is intended to augment the excellent description of the hardware functionality found in the Hardware Functional Specification.

The S1D13705 supports two portrait modes: Default Portrait Mode and Alternate Portrait Mode.

### 7.2 Default Portrait Mode

Default portrait mode was designed to reduce power consumption for portrait mode use. The reduced power consumption comes with certain trade offs.

The most obvious difference between the two modes is that Default Portrait Mode requires the portrait width be a power of two, e.g. a 240-line panel, used in portrait mode, requires setting a virtual width of 256 pixels. Also default portrait mode is only capable of scrolling the display in two line increments.

The benefits to using default portrait mode lies in the ability to use a slower input clock and in reduced power consumption.

The following figure depicts the ways to envision memory layouts for the S1D13705 in default portrait mode. This example uses a 320x240 panel.

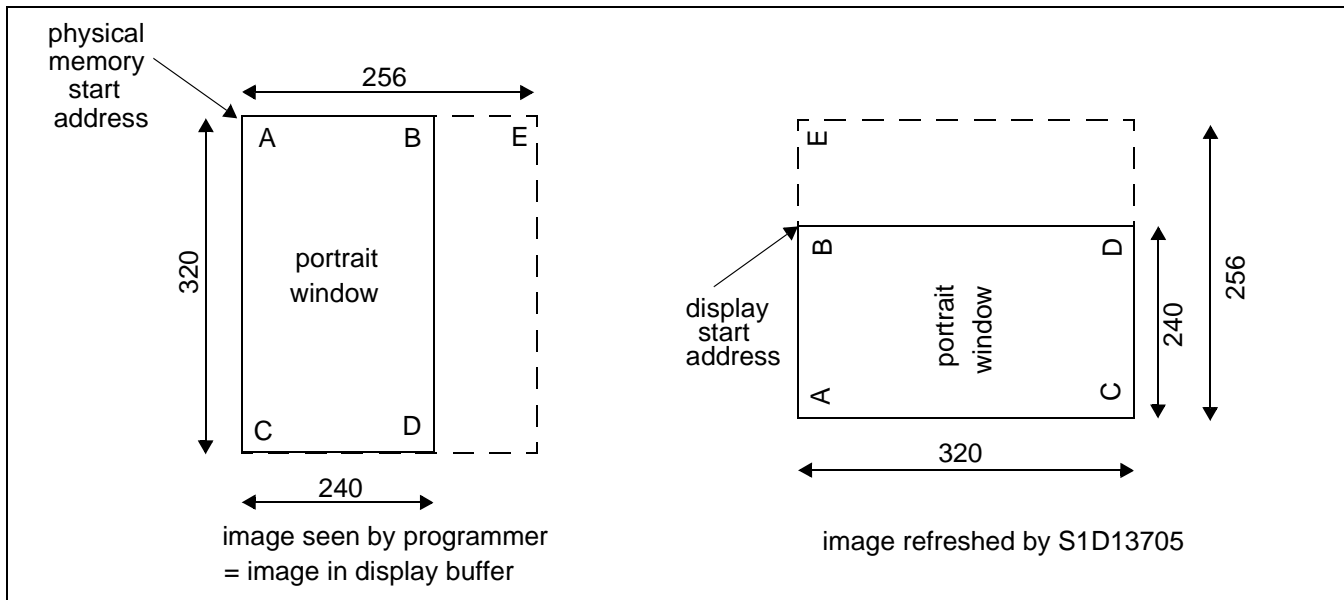

Figure 7-1: Relationship Between the Default Mode Screen Image and the Image Refreshed by S1D13705

From the programmer's perspective the memory is laid out as shown on the left. The programmer accesses memory exactly as for a panel with the dimensions of 240x320 setup to have a 256 pixel horizontal stride. The programmer sees memory addresses increasing from A->B and from B->C.

From a hardware perspective the S1D13705 always refreshes the LCD panel in the order B->D and down to do A->C.

### 7.3 Alternate Portrait Mode

Alternate portrait mode does not impose the power of two line width. To rotated the image on 240 line panel requires a portrait stride of 240 pixels. Alternate portrait mode is capable of scrolling by one line at a time in response to changes to the Start Address Registers. However, to achieve the same frame rate requires a 2 x faster input clock, therefore using more power.

The following figure depicts the ways to envision memory layouts for the S1D13705 in alternate portrait mode. This example also uses a 320x240 panel. Notice that in alternate portrait mode the stride may be as little as 240 pixels.

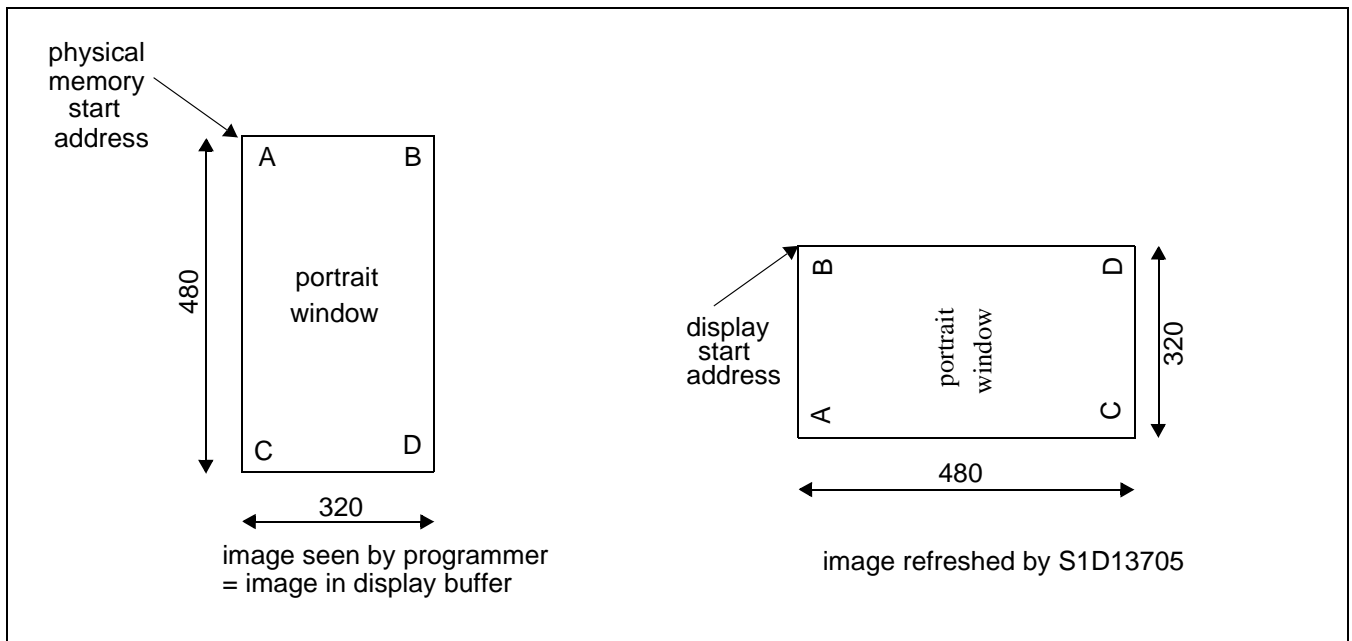

Figure 7-2: Relationship Between the Alternate Mode Screen Image and the Image Refreshed by S1D13705

From the programmers perspective the memory is laid out as shown on the left. The programmer accesses memory exactly as for a panel of with the dimensions of 240x320. The programmer sees memory addresses increasing from A->B and from B->C.

From a hardware perspective the S1D13705 always refreshes the LCD panel in the order B->D and down to do A->C

The greatest factor in selecting alternate portrait mode over default portrait mode would be for the ability to obtain an area of contiguous off screen memory. For example: A 640x480 panel in default portrait mode at two bit-per-pixel requires 81920 bytes (80 Kb). There is unused memory but it is not contiguous. The same situation using alternate portrait mode requires 76800 bytes leaving 5120 bytes of contiguous memory available to the application. In fact the change in memory usage may make the difference between being able to run certain panels in portrait mode or not being able to do so.

## 7.4 Registers

This section describes the registers used to set portrait mode operation.

REG[0Ch] Screen 1 Start Word Address LSB							
bit 7	bit 6	bit 5	bit 4	bit 3	bit 2	bit 1	bit 0

REG[0Dh] Screen 1 Start Word Address MSB							
bit 15	bit 14	bit 13	bit 12	bit 11	bit 10	bit 9	bit 8

REG[0Eh] Screen 1 Start Word Address MSB							
n/a	n/a	n/a	n/a	n/a	n/a	n/a	bit 16

The Screen 1 Start Address registers must be set correctly for portrait mode. In portrait mode the Start Address registers form a byte offset, as opposed to a word offset, into display memory.

The initial required offset is the portrait mode stride (in bytes) less one.

REG[1Ch] Line Byte Count Register							
bit 7	bit 6	bit 5	bit 4	bit 3	bit 2	bit 1	bit 0

The line byte count register informs the S1D13705 of the stride, in bytes, between two consecutive lines of display in portrait mode. The Line Byte Count register only affects portrait mode operation and are ignored when the S1D13705 is in landscape display mode.

REG[1Bh] Portrait Mode Register							
Portrait Mode Enable	Portrait Mode Select	n/a	n/a	n/a	Portrait Mode Memory Clock Select	Portrait Mode Pixel Clock Select Bit 1	Portrait Mode Pixel Clock Select Bit 0

The portrait mode register contains several items for portrait mode support.

The first is the Portrait Mode Enable bit. When this bit is “0” the S1D13705 is in landscape mode and the remainder of the settings in this register as well as the Line Byte Count in REG[1Ch] are ignored. Set this bit to “1” to enable portrait mode.

The portrait mode select bit selects between the “Default Mode” and the “Alternate Mode”. Setting this bit to “0” selects the default portrait mode while setting this bit to “1” enables the alternate portrait mode.

Portrait Mode Memory Clock Select is another power saving measure which can be enabled if the final MCLK value is less than or equal to 25 MHz. Memory Clock Select results in the S1D13705 temporarily increasing the memory clock circuitry on CPU access and resuming the slower speed when the access is complete. This results in better performance while using the least power.

In portrait display mode the CLKI (input clock) is routed to the portrait section of the S1D13705 as CLK. From the CLK signal the MCLK value can be determined from table 8-8 of the Hardware Functional Specification, document number X27A-A-001-xx. If MCLK is determined to be less than or equal to 25 MHz then Portrait Mode Memory Clock Select may be enabled.

## 7.5 Limitations

The only limitation to using portrait mode on the S1D13705 is that split screen operation is not supported.

A comparison of the two portrait modes is as follows:

*Table 7-1: Default and Alternate Portrait Mode Comparison*

Item	Default Portrait Mode	Alternate Portrait Mode
Memory Requirements	The width of the rotated image must be a power of 2. In most cases, a virtual image is required where the right-hand side of the virtual image is unused and memory is wasted. For example, a 320x480x4bpp image would normally require only 76,800 bytes - possible within the 80K byte address space, but the virtual image is 512x480x4bpp which needs 122,880 bytes - not possible.	Does not require a virtual image.
Clock Requirements	CLK need only be as fast as the required PCLK.	MCLK, and hence CLK, need to be 2x PCLK. For example, if the panel requires a 3MHz PCLK, then CLK must be 6MHz. Note that 25MHz is the maximum CLK, so PCLK cannot be higher than 12.5MHz in this mode.
Power Consumption	Lowest power consumption.	Higher than Default Mode.
Panning	Vertical panning in 2 line increments.	Vertical panning in 1 line increments.
Performance	Nominal performance. Note that performance can be increased by increasing CLK and setting MCLK = CLK (REG[1Bh] bit 2 = 1).	Higher performance than Default Mode. Note that performance can be increased by increasing CLK and setting MCLK = CLK (REG[1Bh] bit 2 = 1).



## 7.6 Examples

### **Example 6: Enable default portrait mode for a 320x240 panel at 4 bpp.**

Before switching to portrait mode from landscape mode, display memory should be cleared to make the user perceived transition smoother. Images in display memory are not rotated automatically by hardware and a garbled image would be visible for a short period of time if video memory is not cleared.

If alternate portrait is used then the CLK signal is divided in half to get the PCLK signal. If the Input Clock Divide bit, in register[02] is set we can simply reset the divider. The result of this is a PCLK of exactly the same frequency as we used for landscape mode and we can use the current horizontal and vertical non-display periods. If the Input Clock Divide bit is not set then we must recalculate the frame rate based on the a PCLK value. In this example we will bypass recalculation of the horizontal and vertical non-display times (frame rate) by selecting the default portrait mode scheme.

1. Calculate and set the Screen 1 Start Word Address register.

$$\text{OffsetBytes} = (\text{Width} \times \text{BitsPerPixel} / 8) - 1 = (256 \times 4 / 8) - 1 = 127 = 007\text{Fh}$$

(“Width” is the width of the portrait mode display - in this case the next power of two greater than 240 pixels or 256.)

Set Screen1 Display Start Word Address LSB (REG [0Ch]) to 7Fh and Screen1 Display Start Word Address MSB (REG[0Dh]) to 00h.

2. Calculate the Line Byte Count

The Line Byte Count also must be based on the power of two width.

$$\text{LineByteCount} = \text{Width} \times \text{BitsPerPixel} / 8 = 256 \times 4 / 8 = 128 = 80\text{h.}$$

Set the Line Byte Count (REG[1C]) to 80h.

3. Enable portrait mode.

This example uses the default portrait mode scheme. If we do not change the Portrait Mode Pixel Clock Select bits then we will not have to recalculate the non-display timings to correct the frame rate.

Write 80h to the Portrait Mode Register (REG[1Bh]).

The display is now configured for portrait mode use. Offset zero into display memory will correspond to the upper left corner of the display. The only item to keep in mind is that the count from the first pixel of one line to the first pixel of the next line (referred to as the “stride”) is 128 bytes.

**Example 7: Enable alternate portrait mode for a 320x240 panel at 4 bpp.****Note**

As we have to perform a frame rate calculation for this mode we need to know the following panel characteristics: 320x240 8-bit color to be run at 80 Hz with a 16 MHz input clock.

As in the previous example, before switching to portrait mode, display memory should be cleared. Images in display memory are not rotated automatically by hardware and the garbled image would be visible for a short period of time if video memory is not cleared.

1. Calculate and set the Screen 1 Start Word Address register.

$$\text{OffsetBytes} = (\text{Width} \times \text{BitsPerPixel} / 8) - 1 = (240 \times 4 / 8) - 1 = 119 = 0077\text{h}$$

Set Screen1 Display Start Word Address LSB (REG [0Ch]) to 77h and Screen1 Display Start Word Address MSB (REG[0Dh]) to 00h.

2. Calculate the Line Byte Count.

$$\text{LineByteCount} = \text{Width} \times \text{BitsPerPixel} / 8 = 240 \times 4 / 8 = 120 = 78\text{h.}$$

Set the Line Byte Count (REG[1C]) to 78h.

3. Enable portrait mode.

This example uses the alternate portrait mode scheme. We will not change the MCLK Autoswitch or Pixel Clock Select settings.

Write C0h to the Portrait Mode register (REG[1Bh])

4. Recalculate the frame rate dependents.

This example assumes the alternate portrait mode scheme. In this scheme, without touching the Pixel Clock Select bits the PCLK value will be equal to CLK/2.

These examples don't use the Pixel Clock Select bits. The ability to divide the PCLK value down further than the default values was added to the S1D13705 to support hardware portrait mode on very small panels.

The Pixel Clock value has changed so we must calculate horizontal and vertical non-display times to reach the desired frame rate. Rather than perform the frame rate calculations here I will refer the reader to the frame rate calculations in Frame Rate Calculation on page 9 and simply "arrive" at the following:

$$\text{Horizontal Non-Display Period} = 88\text{h}$$

$$\text{Vertical Non-Display Period} = 03\text{h}$$

Plugging the values into the frame rate calculations yields:

$$\text{FrameRate} = \frac{\text{PCLK}}{(\text{HDP} + \text{HNDP}) \times (\text{VDP} + \text{VNDP})}$$

$$\text{FrameRate} = \frac{\frac{16,000,000}{2}}{(320 + 88) \times (240 + 3)} = 80.69$$

For this example the Horizontal Non-Display register [REG[08h]] needs to be set to 07h and the Vertical Non-Display register (REG[0Ah]) needs to be set to 03h.

The 16,000,000/2 in the formula above represents the input clock being divided by two when this alternate portrait mode is selected. With the values given for this example we must ensure the Input Clock Divide bit (REG[02h] b4) is reset (with the given values it was likely set as a result of the frame rate calculations for landscape display mode).

No other registers need to be altered.

The display is now configured for portrait mode use. Offset zero of display memory corresponds to the upper left corner of the display. Display memory is accessed exactly as it was for landscape mode.

As this is the alternate portrait mode the power of two stride issue encountered with the default portrait mode is no longer an issue. The stride is the same as the portrait mode width. In this case 120 bytes.

***Example 8: Pan the above portrait mode image to the right by 4 pixels then scroll it up by 6 pixels.***

To pan by four pixels the start address needs to be advanced.

1. Calculate the number of bytes to change start address by.

$$\text{Bytes} = \text{Pixels} \times \text{BitsPerPixel} / 8 = 4 \times 4 / 8 = 2 \text{ bytes}$$

2. Increment the start address registers by the just calculated value.

In this case the value write to the start address register will be 81h ( $7Fh + 2 = 81h$ )

To scroll by 4 lines we have to change the start address by the offset of four lines of display.

1. Calculate the number of bytes to change start address by.

$$\text{BytesPerLine} = \text{LineByteCount} = 128$$

$$\text{Bytes} = \text{Lines} \times \text{BytesPerLine} = 4 \times 128 = 512 = 200h$$

2. Increment the start address registers by the just calculated value

In this case 281h ( $81h + 200h$ ) will be written to the Screen 1 Start Address register set.

Set Screen1 Display Start Word Address LSB (REG[0Ch]) to 81h and Screen1 Display Start Word Address MSB (REG[0Dh]) to 02h.

## 8 Identifying the S1D13705

There are several similar products in the 135X and 137X LCD controller families. Products which can share significant portions of a generic code base. It may be important for a program to identify between products at run time.

Identification of the S1D13705 can be performed any time after the system has been powered up by reading REG[00h], the Revision Code register. The six most significant bits form the product identification code and the two least significant bits form the product revision.

From reset (power on) the steps to identifying the S1D13705 are as follows:

1. Read REG[00h]. Mask off the lower two bits, the revision code, to obtain the product code.
2. The product code for the S1D13705 is 024h.

## 9 Hardware Abstraction Layer (HAL)

### 9.1 Introduction

The HAL is a processor independent programming library provided by Epson. The HAL was developed to aid the implementation of internal test programs, and provides an easy, consistent method of programming the S1D13705 on different processor platforms. The HAL also allows for easier porting of programs between S1D1370X products. Integral to the HAL is an information structure (HAL\_STRUCT) that contains configuration data on clocks, display modes, and default register values. This structure combined with the utility 13705CFG.EXE allows quick customization of a program for a new target display or environment.

Using the HAL keeps sample code simpler, although some programmers may find the HAL functions to be limited in their scope, and may wish to program the S1D13705 without using the HAL.

### 9.2 Contents of the HAL\_STRUCT

The HAL\_STRUCT below is contained in the file “hal.h” and is required to use the HAL library.

```
typedef struct tagHalStruct
{
    char    szIdString[16];
    WORD    wDetectEndian;
    WORD    wSize;
    BYTE    Regs [MAX_REG + 1];
    DWORD   dwClkI;           /* Input Clock Frequency (in kHz) */
    DWORD   dwDispMem;       /* Starting address of display buffer memory */
    WORD    wFrameRate;      /* Desired panel frame rate */
} HAL_STRUCT;
```

Within the Regs array is a structure which defines all the registers described in the *S1D13705 Hardware Functional Specification*, document number X27A-A-001-xx. Using the 13705CFG.EXE utility you can adjust the content of the registers contained in HAL\_STRUCT to allow for different LCD panel timing values and other default settings used by the HAL. In the simplest case, the program only calls a few basic HAL functions and the contents of the HAL\_STRUCT are used to setup the S1D13705 for operation.

## 9.3 Using the HAL library

To utilize the HAL library, the programmer must include two “.h” files in their code. “Hal.h” contains the HAL library function prototypes and structure definitions, and “appcfg.h” contains the instance of the HAL\_STRUCT that is defined in “Hal.h” and configured by 13705CFG.EXE. For a more thorough example of using the HAL see Section 10.1, “Sample code using the S1D13705 HAL API” on page 66.

### Note

Many of the HAL library functions have pointers as parameters. The programmer should be aware that little validation of these pointers is performed, so it is up to the programmer to ensure that they adhere to the interface and use valid pointers. Programmers are recommended to use the highest warning levels of their compiler in order to verify the parameter types.

## 9.4 API for 13705HAL

This section is a description of the HAL library Application Programmers Interface (API). Updates and revisions to the HAL may include new functions not included in this documentation.

Table 9-1: HAL Functions

Function	Description
Initialization:	
seRegisterDevice	Registers the S1D13705 parameters with the HAL, calls seInitHal if necessary. seRegisterDevice MUST be the first HAL function called by an application.
seSetInit	Programs the S1D13705 for use with the default settings, calls seSetDisplayMode to do the work, clears display memory. Note: either seSetInit or seSetDisplayMode must be called AFTER calling seRegisterDevice
General HAL Support:	
seGetId	Interpret the revision code register to determine chip id
seGetHalVersion	Return version information on the HAL library
seGetLastUsableByte	Determine the offset of the last unreserved usable byte in the display buffer
seGetBytesPerScanline	Determine the number of bytes or memory consumed per scan line in current mode
seGetScreenSize	Determine the height and width of the display surface in pixels
seDelay	Use the frame rate timing to delay for required seconds (requires registers to be initialized)
seSetHighPerformance	Used in color modes less than 8-bpp to toggle the high performance bit on or off
Advanced HAL Functions:	
seSplitInit	Initialize split screen variables and setup start addresses
seSplitScreen	Set the size of either the top or bottom screen
seVirtInit	Initialize virtual screen mode setting x and y sizes
seVirtMove	pan/scroll the virtual screen surface(s)
Hardware Rotate:	
seSetHWRotate	Set the hardware rotation to either Portrait or Landscape
seSetPortraitMethod	Call before setting hardware portrait mode to set either Default or Alternate Portrait Mode

Table 9-1: HAL Functions (Continued)

Function	Description
<b>Register / Memory Access:</b>	
seSetReg	Write a Byte value to the specified S1D13705 register
seGetReg	Read a Byte value from the specified S1D13705 register
seWriteDisplayBytes	Write one or more bytes to the display buffer at the specified offset
seWriteDisplayWords	Write one or more words to the display buffer at the specified offset
seWriteDisplayDwords	Write one or more dwords to the display buffer at the specified offset
seReadDisplayByte	Read a byte from the display buffer from the specified offset
seReadDisplayWord	Read a word from the display buffer from the specified offset
seReadDisplayDword	Read a dword from the display buffer from the specified offset
<b>Color Manipulation:</b>	
seSetLut	Write to the Look-Up Table (LUT) entries starting at index 0
seGetLut	Read from the LUT starting at index 0
seSetLutEntry	Write one LUT entry (red, green, blue) at the specified index
seGetLutEntry	Read one LUT entry (red, green, blue) from the specified index
seSetBitsPerPixel	Set the color depth
seGetBitsPerPixel	Determine the current color depth
<b>Drawing:</b>	
seSetPixel	Draw a pixel at (x,y) in the specified color
seGetPixel	Read pixel's color at (x,y)
seDrawLine	Draw a line from (x1,y1) to (x2,y2) in specified color
seDrawRect	Draw a rectangle from (x1,y1) to (x2,y2) in specified color
<b>Power Save:</b>	
seSetPowerSaveMode	Control S1D13705 SW power save mode (enable/disable)



## 9.4.1 Initialization

The following section describes the HAL functions dealing with S1D13705 initialization. Typically a programmer has only to concern themselves with calls to `seRegisterDevice()` and `seSetInit()`.

### **int seRegisterDevice(const LPHAL\_STRUC lpHalInfo)**

**Description:** This function registers the S1D13705 device parameters with the HAL library. The device parameters include address range, register values, desired frame rate, etc., and are stored in the HAL\_STRUCT structure pointed to by lpHalInfo. Additionally this routine allocates system memory as address space for accessing registers and the display buffer.

**Parameters:** lpHalInfo - pointer to HAL\_STRUCT information structure

**Return Value:** ERR\_OK - operation completed with no problems  
ERR\_UNKNOWN\_DEVICE - the HAL was unable to find an S1D13705.

#### **Note**

seRegisterDevice() MUST be called before any other HAL functions.  
No S1D13705 registers are changed by calling seRegisterDevice().

### **seSetInit()**

**Description:** Configures the S1D13705 for operation. This function sets all the S1D13705 control registers to their default values.

Initialization of the S1D13705 is a two step process to accommodate those programs (e.g. 13705PLAY.EXE) which do not initialize the S1D13705 on start-up.

**Parameters:** None

**Return Value:** ERR\_OK - operation completed with no problems

#### **Note**

After this call the Look-Up Table will be set to a default state appropriate to the display type.

Unlike S1D1350x HAL versions, this function does not call seSetDisplayMode as this function does not exist in the 13705 HAL.

## 9.4.2 General HAL Support

Functions in this group do not fit into any specific category of support. They provide a miscellaneous range of support for working with the S1D13705

### **int seGetId(int \* pId)**

**Description:** Reads the S1D13705 revision code register to determine the chip product and revisions. The interpreted value is returned in pID.

**Parameters:** pId - pointer to an integer which will receive the controller ID.

S1D13705 values returned in pID are:

- ID\_S1D13705\_REV0
- ID\_UNKNOWN

Other HAL libraries will return their respective controller IDs upon detection of their controller.

**Return Value:** ERR\_OK - operation completed with no problems  
ERR\_UNKNOWN\_DEVICE - the HAL was unable to identify the display controller. Returned when pID returns ID\_UNKNOWN.

### **void seGetHalVersion(const char \*\* pVersion, const char \*\* pStatus, const char \*\*pStatusRevision)**

**Description:** Retrieves the HAL library version. The return pointers are all to ASCII strings. A typical return would be: \*pVersion == "1.01" (HAL version 1.01), \*pStatus == "B" (The 'B' is the beta designator), \*pStatusRevision == "5". The programmer need only create pointers of const char type to pass as parameters (see Example below).

**Parameters:** pVersion - Pointer to string to return the version in.  
- must point to an allocated string of size VER\_SIZE  
pStatus - Pointer to a string to return the release status in.  
- must point to an allocated string of size STATUS\_SIZE  
pStatusRevision - Pointer to return the current revision of status.  
- must point to an allocated string of size STAT\_REV\_SIZE

**Return Value:** None

**Example:** const char \*pVersion, \*pStatus, \*pStatusRevision;  
seGetHalVersion( &pVersion, &pStatus, &pStatusRevision);

### **int seSetBitsPerPixel(int BitsPerPixel)**

**Description:** This routine sets the display color depth.

After performing validity checks to ensure the requested video mode can be set the appropriate registers are changed and the Look-Up Table is set its default values appropriate to the color depth.

This call is similar to a mode set call on a standard VGA.

**Parameter:** BitsPerPixel - desired color depth in bits per pixel.  
- Valid arguments are: 1, 2, 4, and 8.

**Return Value:** ERR\_OK - operation completed with no problems  
ERR\_FAILED- possible causes for this error include:

- 1) the desired frame rate may not be attainable with the specified input clock
- 2) the combination of width, height and color depth may require more memory than is available on the S1D13705.

### **int seGetBitsPerPixel(int \* pBitsPerPixel)**

**Description:** This function reads the S1D13705 registers to determine the current color depth and returns the result in *pBitsPerPixel*.

**Parameters:** pBitsPerPixel - pointer to an integer to receive current color depth.  
- return values will be: 1, 2, 4, or 8.

**Return Value:** ERR\_OK - operation completed with no problems

### **int seGetBytesPerScanline(int \* pBytes)**

**Description:** Determines the number of bytes per scan line of current display mode. It is assumed that the registers have already been correctly initialized before *seGetBytesPerScanline()* is called (i.e. after initializing the HAL, setting the Display mode and adjusting the bits per pixel or other values).

The number of bytes per scanline will include non-displayed bytes if the screen width is greater the display width, or in Default Portrait Mode.

**Parameters:** pBytes - pointer to an integer to receive the number of bytes per scan line

**Return Value:** ERR\_OK - operation completed with no problems

### **int seGetScreenSize(int \* Width, int \* Height)**

**Description:** Retrieves the width and height in pixels of the display surface. The width and height are derived by reading the horizontal and vertical size registers and calculating the dimensions. Virtual dimensions are not taken into account for this calculation.

When the display is in portrait mode the dimensions will be swapped. (i.e. a 640x480 display in portrait mode will return a width of 480 and height of 640).

**Parameters:** Width - pointer to an integer to receive the display width  
Height - pointer to an integer to receive the display height

**Return value:** ERR\_OK - the operation completed successfully

### **int seDelay(int MilliSeconds)**

**Description:** This function will delay for the length of time specified in “MilliSeconds” before returning to the caller.

This function was originally intended for non-PC platforms. Information about how to access the timers was not always available however we do know frame rate and can use that for timing calculations.

The S1D13705 registers must be initialized for this function to work correctly. On the PC platform this is simply a call to the C timing functions and is therefore independent of the register settings.

**Parameters:** MilliSeconds- time to delay in seconds

**Return Value:** ERR\_OK - operation completed with no problems  
ERR\_FAILED- returned on non-PC platforms when the S1D13705 registers have not been initialized

### **int seGetLastUsableByte(long \* pLastByte)**

**Description:** This function returns a pointer, as a long integer, to the last byte of usable display memory.

The returned value never changes for the S1D13705.

**Parameters:** pLastByte - pointer to a long integer to receive the offset to the last byte of display memory

**Return Value:** ERR\_OK - operation completed with no problems

### **int seSetHighPerformance(BOOL OnOff)**

**Description:** This function call enables or disable the high performance bit of the S1D13705.

When high performance is enabled then MClk equals PClk for all video display resolutions. In the high performance state CPU to video memory performance is improved at the cost of higher power consumption.

When high performance is disabled then MClk ranges from PClk/1 at 8 bit-per-pixel to PClk/8 at 1 bit-per-pixel. Without high performance CPU to video memory speeds are slower and the S1D13705 uses less power.

**Parameters:** OnOff - a boolean value (defined in HAL.H) to indicate whether to enable or disable high performance.

**Return Value:** ERR\_OK - operation completed with no problems

## **9.4.3 Advanced HAL Functions**

Advanced HAL functions include the functions to support split, virtual and rotated displays. While the concept for using these features is advanced the HAL makes actually using them easy.

### **int seSetPortraitMethod( int Style )**

**Description:** This selects the portrait mode method to be used when seSetHWRotate() is called to put the S1D13705 into portrait mode.

**Parameters:** Style - call with style set to DEFAULT (-1) to select Default Portrait Mode  
- call with style set to any other value to select Alternate Portrait Mode.

**Return Value:** ERR\_OK - operation completed with no problems  
ERR\_FAILED - the operation failed.

### **int seSetHWRotate(int Rotate)**

**Description:** This function sets the rotation scheme according to the value of 'Rotate'. When portrait mode is selected as the display rotation the scheme selected is the 'non-X2' scheme.

**Parameters:** Rotate - the direction to rotate the display  
- Valid arguments for Rotate are: LANDSCAPE and PORTRAIT.

**Return Value:** ERR\_OK - operation completed with no problems  
ERR\_FAILED - the operation failed to complete.

The most likely reason for failing to set a rotate mode is an inability to set the desired frame rate when setting portrait mode. Other factors which can cause a failure include having a 0 Hz frame rate or specifying a value other than LANDSCAPE or PORTRAIT for the rotation scheme.

**int seSplitInit(WORD Scrn1Addr, WORD Scrn2Addr)**

**Description:** This function prepares the system for split screen operation. In order for split screen to function the starting address in the display buffer for the upper portion(screen 1) and the lower portion (screen 2) must be specified. Screen 1 is always displayed above screen 2 on the display regardless of the location of their start addresses.

**Parameters:** Scrn1Addr - offset, in bytes, to the start of screen 1  
Scrn2Addr - offset, in bytes, to the start of screen 2

**Return Value:** ERR\_OK - operation completed with no problems

**Note**

It is assumed that the system has been initialized prior to calling seSplitInit().

**int seSplitScreen(int Screen, int VisibleScanlines)**

**Description:** Changes the relevant registers to adjust the split screen according to the number of visible lines requested. 'WhichScreen' determines which screen, 1 or 2, to base the changes on.

The smallest surface screen 1 can display is one line. This is due to the way the S1D13705 operates. Setting Screen 1 Vertical Size to zero results in one line of screen 1 being displayed. The remainder of the display will be screen 2 image.

**Parameters:** Screen - must be set to 1 or 2 (or use the constants SCREEN1 or SCREEN2)  
VisibleScanlines- number of lines to display for the selected screen

**Return Value:** ERR\_OK - operation completed with no problems  
ERR\_HAL\_BAD\_ARG- argument VisibleScanlines is negative or is greater than vertical panel size or WhichScreen is not SCREEN1 or SCREEN 2.

**Note**

Changing the number of lines for one screen will also change the number of lines for the other screen.

seSplitInit() must be called before calling seSplitScreen().

## **int seVirtInit(DWORD VirtX, DWORD \* VirtY)**

**Description:** This function prepares the system for virtual screen operation. The programmer passes the desired virtual width in pixels. When the routine returns *VirtY* will contain the maximum number of line that can be displayed at the requested virtual width.

**Parameter:** VirtX - horizontal size of virtual display in pixels.  
(Must be greater or equal to physical size of display)  
VirtY - pointer to an integer to receive the maximum number of displayable lines of 'VirtX' width.

**Return Value:** ERR\_OK - operation completed with no problems  
ERR\_HAL\_BAD\_ARG - returned in three situations:  
1) the virtual width (VirtX) is greater than the largest possible width (VirtX varies with color depth and ranges from 4096 pixels wider than the panel at 1 bit-per-pixel down to 512 pixels wider than the panel at 8 bit-per-pixel)  
2) the virtual width is less than the physical width or  
3) the maximum number of lines becomes less than the physical number of lines

### **Note**

The system must have been initialized prior to calling seVirtInit()

## **int seVirtMove(int Screen, int x, int y)**

**Description:** This routine pans and scrolls the display. In the case where split screen operation is being used, the Screen argument specifies which screen to move. The x and y parameters specify, in pixels, the starting location in the virtual image for the top left corner of the applicable display.

**Parameter:** Screen - must be set to 1 or 2, or use the constants SCREEN1 or SCREEN2, to identify which screen to base calculations on  
x - new starting X position in pixels  
y - new starting Y position in pixels

**Return Value:** ERR\_OK - operation completed with no problems  
ERR\_HAL\_BAD\_ARG- there are several reasons for this return value:  
1) WhichScreen is not SCREEN1 or SCREEN2.  
2) the y argument is greater than the last available line less the screen height.

### **Note**

seVirtInit() must be called before calling seVirtMove().

## 9.4.4 Register / Memory Access

The Register/Memory Access functions provide access to the S1D13705 registers and display buffer through the HAL.

### **int seGetReg(int Index, BYTE \* pValue)**

**Description:** Reads the value in the register specified by index.

**Parameters:** Index - register index to read  
pValue - pointer to a BYTE to receive the register value.

**Return Value:** ERR\_OK - operation completed with no problems

### **int seSetReg(int Index, BYTE Value)**

**Description:** Writes value specified in Value to the register specified by Index.

**Parameters:** Index - register index to set  
Value - value to write to the register

**Return Value:** ERR\_OK - operation completed with no problems

### **int seReadDisplayByte(DWORD Offset, BYTE \*pByte)**

**Description:** Reads a byte from the display buffer at the specified offset and returns the value in pByte.

**Parameters:** Offset - offset, in bytes from start of the display buffer, to read from  
pByte - pointer to a BYTE to return the value in

**Return Value:** ERR\_OK - operation completed with no problems  
ERR\_HAL\_BAD\_ARG - if the value for Addr is greater 80 kb

### **int seReadDisplayWord(DWORD Offset, WORD \*pWord)**

**Description:** Reads a word from the display buffer at the specified offset and returns the value in pWord.

**Parameters:** Offset - offset, in bytes from start of the display buffer, to read from  
pWord - pointer to a WORD to return the value in

**Return Value:** ERR\_OK - operation completed with no problems.  
ERR\_HAL\_BAD\_ARG - if the value for Addr is greater than 80 kb.



### **int seReadDisplayDword(DWORD Offset, DWORD \*pDword)**

**Description:** Reads a dword from the display buffer at the specified offset and returns the value in pDword.

**Parameters:** Offset - offset from start of the display buffer to read from  
pDword - pointer to a DWORD to return the value in

**Return Value:** ERR\_OK - operation completed with no problems.  
ERR\_HAL\_BAD\_ARG - if the value for Addr is greater than 80 kb.

### **int seWriteDisplayBytes(DWORD Offset, BYTE Value, DWORD Count)**

**Description:** This routine writes one or more bytes to the display buffer at the offset specified by Offset. If a count greater than one is specified all bytes will have the same value.

**Parameters:** Offset - offset from start of the display buffer to start writing at  
Value - BYTE value to write  
Count - number of bytes to write

**Return Value:** ERR\_OK - operation completed with no problems  
ERR\_HAL\_BAD\_ARG - if the value for Addr or the value of Addr plus Count is greater than 80 kb.

#### **Note**

There are slight functionality differences between the S1D1370x and the S1D1350x HAL.

### **int seWriteDisplayWords(DWORD Offset, WORD Value, DWORD Count)**

**Description:** Writes one or more WORDS to the display buffer at the offset specified by Addr. If a count greater than one is specified all WORDS will have the same value.

**Parameters:** Offset - offset from start of the display buffer  
Value - WORD value to write  
Count - number of words to write

**Return Value:** ERR\_OK - operation completed with no problems  
ERR\_HAL\_BAD\_ARG - if the value for Addr or if Addr plus Count is greater than 80 kb.

#### **Note**

There are slight functionality differences between the S1D1370x and the S1D1350x HAL.

**int seWriteDisplayDwords(DWORD Offset, DWORD Value, DWORD Count)**

**Description:** Writes one or more DWORDS to the display buffer at the offset specified by Addr. If a count greater than one is specified all DWORDSs will have the same value.

**Parameters:** Offset - offset from start of the display buffer  
Value - DWORD value to write  
Count - number of dwords to write

**Return Value:** ERR\_OK - operation completed with no problems  
ERR\_HAL\_BAD\_ARG - if the value for Addr or if Addr plus Count is greater than 80 kb.

**Note**

There are slight functionality differences between the S1D1370x and the S1D1350x HAL.

## 9.4.5 Power Save

This section covers the HAL functions dealing with the Power Save features of the S1D13705.

**int seSetPowerSaveMode(int PwrSaveMode)**

**Description:** This function sets on the S1D13705's software selectable power save modes.

**Parameters:** PwrSaveMode - integer value specifying the desired power save mode.

Acceptable values for PwrSaveMode are:

0 - (software power save mode) in this mode registers and memory are read/writable. LCD output is forced low.

3 - (normal operation) all outputs function normally.

**Return Value:** ERR\_OK - operation completed with no problems

## 9.4.6 Drawing

The Drawing routines cover HAL functions that deal with displaying pixels, lines and shapes.

### **int seSetPixel(long x, long y, DWORD Color)**

**Description:** Draws a pixel at coordinates (x,y) in the requested color. This routine can be used for any color depth.

**Parameters:** x - horizontal coordinate of the pixel (starting from 0)  
y - vertical coordinate of the pixel (starting from 0)  
Color - at 1, 2, 4, and 8 bpp Color is an index into the LUT.  
At 15 and 16 bpp Color defines the color directly  
(i.e. rrrrrgggggbbbb for 16 bpp)

**Return Value:** ERR\_OK - operation completed with no problems.

### **int seGetPixel(long x, long y, DWORD \*pColor)**

**Description:** Reads the pixel color at coordinates (x,y). This routine can be used for any color depth.

**Parameters:** x - horizontal coordinate of the pixel (starting from 0)  
y - vertical coordinate of the pixel (starting from 0)  
pColor - at 1, 2, 4, and 8 bpp pColor points to an index into the LUT.  
At 15 and 16 bpp pColor points to the color directly  
(i.e. rrrrrgggggbbbb for 16 bpp)

**Return Value:** ERR\_OK - operation completed with no problems.

### **int seDrawLine(int x1, int y1, int x2, int y2, DWORD Color)**

**Description:** This routine draws a line on the display from the endpoints defined by x1,y1 to the endpoint x2,y2 in the requested 'Color'.

Currently seDrawLine() only draws horizontal and vertical lines.

**Parameters:** (x1, y1) - first endpoint of the line in pixels  
(x2, y2) - second endpoint of the line in pixels (see note below)  
Color - color to draw with. 'Color' is an index into the LUT.

**Return Value:** ERR\_OK - operation completed with no problems

#### **Note**

Functionality differs from the 135x HAL.

**int seDrawRect(long x1, long y1, long x2, long y2, DWORD Color, BOOL SolidFill)**

**Description:** This routine draws and optionally fills a rectangular area of display buffer. The upper right corner is defined by x1,y1 and the lower right corner is defined by x2,y2. The color, defined by *Color*, applies both to the border and to the optional fill.

**Parameters:**

x1, y1	- top left corner of the rectangle (in pixels)
x2, y2	- bottom right corner of the rectangle (in pixels)
Color	- The color to draw the rectangle outline and fill with - Color is an index into the Look-Up Table.
SolidFill	- Flag whether to fill the rectangle or simply draw the border. - Set to 0 for no fill, set to non-0 to fill the inside of the rectangle

**Return Value:** ERR\_OK - operation completed with no problems.

**9.4.7 LUT Manipulation**

These functions deal with altering the color values in the Look-Up Table.

**int seSetLut(BYTE \*pLut, int Count)**

**Description:** This routine writes one or more LUT entries. The writes always start with Look-Up Table index 0 and continue for 'Count' entries.

A Look-Up Table entry consists of three bytes, one each for Red, Green, and Blue. The color information is stored in the four most significant bits of each byte.

**Parameters:**

pLut	- pointer to an array of BYTE lut[16][3] lut[x][0] == RED component lut[x][1] == GREEN component lut[x][2] == BLUE component
Count	- the number of LUT entries to write.

**Return Value:** ERR\_OK - operation completed with no problems

**int seGetLut(BYTE \*pLUT, int Count)**

**Description:** This routine reads one or more LUT entries and puts the result in the byte array pointed to by pLUT.

A Look-Up Table entry consists of three bytes, one each for Red, Green, and Blue. The color information is stored in the four most significant bits of each byte.

**Parameters:**

pLUT	- pointer to an array of BYTE lut[16][3] - pLUT must point to enough memory to hold 'Count' x 3 bytes of data.
Count	- the number of LUT elements to read.

**Return Value:** ERR\_OK - operation completed with no problems

### **int seSetLutEntry(int Index, BYTE \*pEntry)**

**Description:** This routine writes one LUT entry. Unlike seSetLut, the LUT entry indicated by 'Index' can be any value from 0 to 255.

A Look-Up Table entry consists of three bytes, one each for Red, Green, and Blue. The color information is stored in the four most significant bits of each byte.

**Parameters:** Index - index to LUT entry (0 to 255)  
pLUT - pointer to an array of three bytes.

**Return Value:** ERR\_OK - operation completed with no problems

### **int seGetLutEntry(int index, BYTE \*pEntry)**

**Description:** This routine reads one LUT entry from any index.

A Look-Up Table entry consists of three bytes, one each for Red, Green, and Blue. The color information is stored in the four most significant bits of each byte.

**Parameters:** Index - index to LUT entry (0 to 255)  
pEntry - pointer to an array of three bytes

**Return Value:** ERR\_OK - operation completed with no problems

## 9.5 Porting LIBSE to a new target platform

Building Epson Research and Development applications like a simple HelloApp for a new target platform requires 3 things, the HelloApp code, the 13705HAL library, and a some standard C functions (portable ones are encapsulated in our mini C library LIBSE).

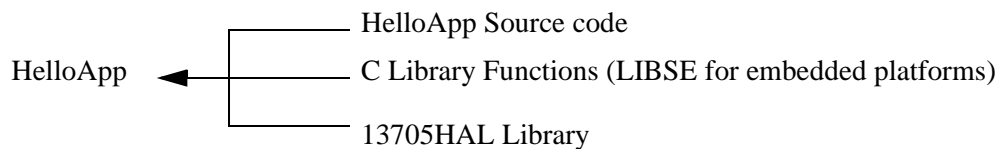

Components needed to build 13705 HAL application

For example, when building HELLOAPP.EXE for the Intel 16-bit platform, you need the HELLOAPP source files, the 13705HAL library and its include files, and some Standard C library functions (which in this case would be supplied by the compiler as part of its runtime library). As this is a DOS .EXE application, you do not need to supply start-up code that sets up the chip selects or interrupts, etc... What if you wanted to build the application for an SH-3 target, one not running DOS?

Before you can build that application to load onto the target, you need to build a C library for the target that contains enough of the Standard C functions (like `sprintf` and `strcpy`) to let you build the application. Epson Research and Development supplies the LIBSE for this purpose, but your compiler may come with one included. You also need to build the 13705HAL library for the target. This library is the graphics chip dependent portion of the code. Finally, you need to build the final application, linked together with the libraries described earlier. The following examples assume that you have a copy of the complete source code for the S1D13705 utilities, including the `nmake` makefiles, as well as a copy of the GNU Compiler v2.7-96q3a for Hitachi SH3. These are available on the World Wide Web at <http://www.erd.epson.com>.

## 9.5.1 Building the LIBSE library for SH3 target example

In the LIBSE files, there are three main types of files:

- C files that contain the library functions.
- assembler files that contain the target specific code.
- makefiles that describe the build process to construct the library.

The C files are generic to all platforms, although there are some customizations for targets in the form of `#ifdef LCEVB` code (the `SH3` target Low Cost Eval Board `SH3`). The majority of this code remains constant whichever target you build for.

The assembler files contain some platform setup code (stacks, chip selects) and jumps into the main entry point of the C code that is contained in the C file `entry.c`. For our example, the assembler file is `STARTSH3.S` and it performs only some stack setup and a jump into the code at `_mainEntry` (`entry.c`).

In the embedded targets, `printf` (in file `rprintf.c`), `putchar` (`putchar.c`) and `getch` (`kb.c`) resolve to serial character input/output. For `SH3`, much of the detail of handling serial IO is hidden in the monitor of the evaluation board, but in general the primitives are fairly straight forward, providing the ability to get characters to/from the serial port.

For our target example, the `nmake` makefile is `makesh3.mk`. This makefile calls the Gnu compiler at a specific location (`TOOLDIR`), enumerates the list of files that go into the target and builds a `.a` library file as the output of the build process.

With `nmake.exe` in your path run:

```
nmake -fmakesh3.mk
```

## 9.5.2 Building the HAL library for the target example

Building the HAL for the target example is less complex because the code is written in C and requires little platform specific adjustment. The `nmake` makefile for our example is `makesh3.mk`. This makefile contains the rules for building `sh3` objects, the files list for the library and the library creation rules. The Gnu compiler tools are pointed to by `TOOLDIR`.

With `nmake` in your path run:

```
nmake -fmakesh3.mk
```

## 10 Sample Code

Included in the sample code section are two examples of programming the S1D13705. The first sample uses the HAL to draw a red square, wait for user input then rotates to portrait mode and draws a blue square. The second sample code performs the same procedures but directly accesses the registers of the S1D13705. These code samples are for example purposes only.

### 10.1 Sample code using the S1D13705 HAL API

```

/*
**=====
** SAMPLE1.C - Sample code demonstrating a program using the S1D13705 HAL.
**-----
** Created 1998, Vancouver Design Centre
** Copyright (c) 1998, 1999 Epson Research and Development, Inc.
** All Rights Reserved.
**-----
**
** The HAL API code is configured for the following:
**
** 320x240 Single Color 4-bit STN
** 8 bpp - 70 Hz Frame Rate (6 MHz CLKi)
** High Performance enabled
**
**=====
*/
#include <conio.h>
#include <stdio.h>
#include <stdlib.h>
#include <string.h>
#include "hal.h"           /* Structures, constants and prototypes. */
#include "appcfg.h"       /* HAL configuration information. */
/*-----*/
void main(void)
{
    int    ChipId;
    /*
    ** Initialize the HAL.
    ** The call to seRegisterDevice() actually prepares the HAL library
    ** for use. The S1D13705 is not accessed, except to read the revision
    ** code register.
    */
    if (ERR_OK != seRegisterDevice(&HalInfo))
    {
        printf("\nERROR: Could not register S1D13705 device.");
        exit(1);
    }
}

```



```
/*
** Get the product code to verify this is an S1D13705.
*/
seGetId(&ChipId);
if (ID_S1D13705_Rev1 != ChipId)
{
    printf("\nERROR: Did not detect an S1D13705.");
    exit(1);
}
/*
** Initialize the S1D13705.
** This step programs the registers with values taken from
** the HalInfo struct in appcfg.h.
*/
if (ERR_OK != seSetInit())
{
    printf("\nERROR: Could not initialize device.");
    exit(1);
}
/*
** The default initialization cleared the display.
** Draw a 100x100 red (color 1) rectangle in the upper
** left corner (0,0) of the display.
*/
seDrawRect(0, 0, 100, 100, 1, TRUE);
/*
** Pause here.
*/
getch();
/*
** Clear the display. Do this by writing 81920 bytes
*/
seWriteDisplayBytes(0, 0, EIGHTY_K);
/*
** Setup portrait mode.
*/
seSetHWRotate(PORTRAIT);
/*
** Draw a solid blue 100x100 rectangle in center of the display.
** This starting co-ordinates, assuming a 320x240 display is
** (320-100)/2 , (240-100)/2 = 110,70.
*/
seDrawRect(110, 70, 210, 170, 2, TRUE);
/*
** Done!
*/
exit(0);
}
```

## 10.2 Sample code without using the S1D13705 HAL API

This second sample demonstrates exactly the same sequence as the first however the HAL is not used, all manipulation is done by directly accessing the registers.

```

/*
**=====
** SAMPLE2.C - Sample code demonstrating a direct access of the S1D13705.
**-----
** Created 1998, Vancouver Design Centre
** Copyright (c) 1998, 1999 Epson Research and Development, Inc.
** All Rights Reserved.
**-----
**
** The sample code using direct S1D13705 access
** will configure for the following:
**
** 320x240 Single Color 4-bit STN
** 8 bpp color depth - 70 Hz Frame Rate (6 MHz CLKi)
**
** Notes:
** 1) This code is written to be compiled for use under 32-bit
**    Windows. In order to function the vxd file S1D13X0X.VXD must
**    be in the \WINDOWS\SYSTEM directory.
** 2) Register setup is done with discreet writes rather than being table
**    driven. This allows for clear commenting. It is more efficient to
**    loop through the array writing each element to a control register.
** 3) The array of register values as produced by 13705CFG.EXE is included
**    here. I write the registers directly rather than refer to the register
**    array in the sample code.
**
**=====
*/
#include <conio.h>
#include <windows.h>
#include <winioctl.h>
#include "ioctl.h"
/*
** Look-Up Table - 16 of 256 elements.
** For this sample only the first sixteen LUT elements are set.
*/
unsigned char LUT[16*3] =
{
    0x00, 0x00, 0x00, /* BLACK */
    0x00, 0x00, 0xA0, /* BLUE */
    0x00, 0xA0, 0x00, /* GREEN */
    0x00, 0xA0, 0xA0, /* CYAN */
    0xA0, 0x00, 0x00, /* RED */
    0xA0, 0x00, 0xA0, /* PURPLE */

```

```
    0xA0, 0xA0, 0x00, /* YELLOW */
    0xA0, 0xA0, 0xA0, /* WHITE  */
    0x00, 0x00, 0x00, /* BLACK  */
    0x00, 0x00, 0xF0, /* LT BLUE */
    0x00, 0xF0, 0x00, /* LT GREEN */
    0x00, 0xF0, 0xF0, /* LT CYAN  */
    0xF0, 0x00, 0x00, /* LT RED   */
    0xF0, 0x00, 0xF0, /* LT PURPLE */
    0xF0, 0xF0, 0x00, /* LT YELLOW */
    0xF0, 0xF0, 0xF0 /* LT WHITE */
};
/*
** Register data.
** These values were generated using 13705CFG.EXE.
** The sample code uses these values but does not refer to this array.
** In a typical application these values would be written to the registers
** using a loop.
*/
unsigned char Reg[0x20] =
{
    0x00, 0x23, 0xC0, 0x03, 0x27, 0xEF, 0x00, 0x00,
    0x00, 0x00, 0x03, 0x00, 0x00, 0x00, 0x00, 0x00,
    0x00, 0x00, 0xFF, 0x03, 0x00, 0x00, 0x00, 0x00,
    0x00, 0x00, 0x00, 0x00, 0x00
};
#define MEM_SIZE 0x14000 /* 80 kb display buffer. */
typedef unsigned short WORD; /* Some useful types */
typedef unsigned long  DWORD;
typedef unsigned char  BYTE;
typedef BYTE           *  PBYTE;
#define LOBYTE(w)      ((BYTE)(w))
#define HIBYTE(w)      ((BYTE)(((WORD)(w) >> 8) & 0xFF))
#define SET_REG(idx, val) (*(pRegs + idx)) = (val)
/*-----*/
void main(void)
{
    PBYTE p13705;
    PBYTE pRegs;
    PBYTE pMem;
    PBYTE pLUT;
    int x, y, tmp;
    int BitsPerPixel = 8;
    int Width        = 320;
    int Height       = 240;
    int OffsetBytes;
    int rc;
    /*
    ** Get a linear address we can use in our code to access the S1D13705.
    ** This is only needed to access the S1D13705 on the ISA eval board.
    */

```

```
*/
DWORD dwLinearAddress;
rc = IntelGetLinAddressW32(0xF00000, &dwLinearAddress);
if (rc != 0)
{
    printf("Error getting linear address");
    return;
}
p13705 = (PBYTE)dwLinearAddress;
pRegs = p13705 + 0x1FFE0;
/*
** Check the revision code. Exit if we don't find an S1D13705.
*/
if (0x24 != *pRegs)
{
    printf("Didn't find an S1D13705");
    return;
}
/*
** Initialize the chip - after initialization the display will be
** setup for landscape use.
** Normally a loop would be used to write the register array near
** the top of this file to the registers.
** For purposes of documenting the sample code, each register write
** is performed individually.
*/
/*
** Register 01h: Mode Register 0 - Color, 8-bit format 2
*/
SET_REG(0x01, 0x20);
/*
** Register 02h: Mode Register 1 - 8BPP
*/
SET_REG(0x02, 0xC0);
/*
** Register 03h: Mode Register 2 - Normal power mode
*/
SET_REG(0x03, 0x03);
/*
** Register 04h: Horizontal Panel Size - 320 pixels - (320/8)-1 = 39 = 27h
*/
SET_REG(0x04, 0x27);
/*
** Register 05h: Vertical Panel Size LSB - 240 pixels
** Register 06h: Vertical Panel Size MSB - (240 - 1) = 239 = EFh
*/
SET_REG(0x05, 0xEF);
SET_REG(0x06, 0x00);
/*
```

```

** Register 07h - FPLINE Start Position - not used by STN
*/
SET_REG(0x07, 0x00);
/*
** Register 08h - Horizontal Non-Display Period = (Reg[08] + 4) * 8
**                                     = (0+4) * 8 = 32 pels
** - HNDP and VNDP are calculated to achieve the
**   desired frame rate according to:
**
**                                     PCLK
**   Frame Rate = -----
**                 (HDP + HNDP) * (VDP + VNDP)
*/
SET_REG(0x08, 0x00);
/*
** Register 09h - FPFRAME Start Position - not used by STN
*/
SET_REG(0x09, 0x00);
/*
** Register 0Ah - Vertical Non-Display Register = 3 lines
** - Calculated in conjunction with register 08h (HNDP) to
**   achieve the desired frame rate.
*/
SET_REG(0x0A, 0x03);
/*
** Register 0Bh - MOD Rate - not used by this panel
*/
SET_REG(0x0B, 0x00);
/*
** Register 0Ch - Screen 1 Start Word Address LSB
** Register 0Dh - Screen 1 Start Word Address MSB
** - Start address should be set to 0
*/
SET_REG(0x0C, 0x00);
SET_REG(0x0D, 0x00);
/*
** Register 0Eh - Screen 2 Start Word Address LSB
** Register 0Fh - Screen 2 Start Word Address MSB
** - Set this start address to 0 too
*/
SET_REG(0x0E, 0x00);
SET_REG(0x0F, 0x00);
SET_REG(0x10, 0x00); /* Screen1/Screen2 Start Address High bits. */
/*
** Register 11h - Memory Address Offset
** - Used for setting memory to a width greater than the
**   display size. Usually set to 0 during initialization
**   and programmed to desired value later.
*/

```

```
SET_REG(0x11, 0x00);
/*
** Register 12h - Screen 1 Vertical Size LSB
** Register 13h - Screen 1 Vertical Size MSB
**           - Set to maximum (i.e. 0x3FF). This register is used
**           for split screen operation. Normally it is set to
**           maximum value.
*/
SET_REG(0x12, 0xFF);
SET_REG(0x13, 0x03);
/*
** Look-Up Table registers
** The LUT is programmed at the end of the initialization sequence.
*/
/*
** Register 18h - GPIO Configuration - set to 0
**           - '0' configures the GPIO pins for input (power on default)
*/
SET_REG(0x18, 0x00);
/*
** Register 19h - GPIO Status - set to 0
**           - This step has no real purpose. It sets the GPIO
**           pins low should GPIO be set as outputs.
*/
SET_REG(0x19, 0x00);
/*
** Register 1Ah - Scratch Pad - set to 0
**           - Use this register to store whatever state data your
**           system may require.
*/
SET_REG(0x1A, 0x00);
/*
** Register 1Bh - Portrait Mode - set to 0 - disable portrait mode
*/
SET_REG(0x1B, 0x00);
/*
** Register 1Ch - Line Byte Count - set to 0 - used only by portrait mode.
*/
SET_REG(0x0C, 0x00);
/*
** Look-Up Table
** In this example we only set the first sixteen LUT entries.
** In typical use all 256 entries would be setup.
*/
/*
** Register 15h - Look-Up Table Address
**           - Set to 0 to start RGB sequencing at the first LUT entry.
*/
SET_REG(0x15, 0x00);
```

```
/*
** Register 17h - Look-Up Table Data
**           - Write 16 RGB triplets to the LUT.
*/
pLUT = LUT;
for (tmp = 0; tmp < 16; tmp++)
{
    SET_REG(0x17, *pLUT); // Set Red
    pLUT++;
    SET_REG(0x17, *pLUT); // Set Green
    pLUT++;
    SET_REG(0x17, *pLUT); // Set Blue
    pLUT++;
}
/*
** Clear all of video memory by writing 81920 bytes of 0.
*/
pMem = p13705;
for (tmp = 0; tmp < MEM_SIZE; tmp++)
{
    *pMem = 0;
    pMem++;
};
/*
** Draw a 100x100 red rectangle in the upper left corner (0,0)
** of the display.
*/
for (y = 0; y < 100; y++)
{
    /*
    ** Set the memory pointer at the start of each line.
    **   Pointer = MEM_OFFSET + (Y * Line_Width * BPP / 8) + (X * BPP / 8)
    */
    pMem = p13705 + (y * 320 * BitsPerPixel / 8) + 0;
    for (x = 0; x < 100; x++)
    {
        *pMem = 0x4; /* Draw a pixel with LUT color 4 */
        pMem++;
    }
}
/*
** Wait for the user to press a key before continuing.
*/
printf("Press any key to continue");
getch();
/*
** Set and use PORTRAIT mode.
*/
/*
```

```

** Clear the display, and all of video memory, by writing 81920 bytes
** of 0. This is done because an image in display memory is not rotated
** when the switch to portrait display mode occurs.
*/
pMem = p13705;
for (tmp = 0; tmp < MEM_SIZE; tmp++)
{
    *pMem = 0;
    pMem++;
};
/*
** We will use the default portrait mode scheme so we have to adjust
** the ROTATED width to be a power of 2.
** (NOTE: current height will become the rotated width)
*/
tmp = 1;
while (Height > (1 << tmp))
tmp++;
Height = (1 << tmp);
OffsetBytes = Height * BitsPerPixel / 8;
/*
** Set:
** 1) Line Byte Count to size of the ROTATED width (i.e. current height)
** 2) Start Address to the offset of the width of the ROTATED display.
**    (in portrait mode the start address registers point to bytes)
*/
SET_REG(0x1C, (BYTE)OffsetBytes);
OffsetBytes--;
SET_REG(0x0C, LOBYTE(OffsetBytes));
SET_REG(0x0D, HIBYTE(OffsetBytes));
/*
** Set Portrait mode.
** Use the non-X2 (default) scheme so we don't have to re-calc the frame
** rate. MCLK will be <= 25 MHz so we can leave auto-switch enabled.
*/
SET_REG(0x1B, 0x80);
/*
** Draw a solid blue 100x100 rectangle centered on the display.
** Starting co-ordinates, assuming a 320x240 display are:
**    (320-100)/2 , (240-100)/2 = 110,70.
*/
for (y = 70; y < 180; y++)
{
    /*
    ** Set the memory pointer at the start of each line.
    **    Pointer = MEM_OFFSET + (Y * Line_Width * BPP / 8) + (X * BPP / 8)
    ** NOTICE: as this is default portrait mode, the width is a power
    **          of two. In this case, we use a value of 256 pixels for
    **          our calculations instead of the panel dimension of 240.
    */

```



```
        */
        x = 110;
        pMem = p13705 + (y * 256 * BitsPerPixel / 8) + (x * BitsPerPixel / 8);
        for (x = 110; x < 210; x++)
        {
            *pMem = 0x01;          /* Draw a pixel in LUT color 1 */
            pMem++;
        }
    }
}
/*
**=====
**
** IntelGetLinAddressW32(DWORD physaddr,DWORD *linaddr)
**
** return value:
**
**     0 : No error
**    -1 : Error
**
*/
int IntelGetLinAddressW32(DWORD physaddr, DWORD *linaddr)
{
    HANDLE hDriver;
    DWORD  cbReturned;
    int     rc, retVal;
    unsigned Arr[2];
    // First see if we are running under WinNT
    DWORD dwVersion = GetVersion();
    if (dwVersion < 0x80000000)
    {
        hDriver = CreateFile("\\\\.\\S1D13x0x", GENERIC_READ | GENERIC_WRITE,
                            0, NULL, OPEN_EXISTING, FILE_ATTRIBUTE_NORMAL,
                            NULL);
    }
    else // Win95/98
    {
        // Dynamically load and prepare to call S1D13x0x.
        // The FILE_FLAG_DELETE_ON_CLOSE flag is used so that CloseHandle can
        // be used to dynamically unload the VxD.
        // The CREATE_NEW flag is not necessary
        hDriver = CreateFile("\\\\.\\S1D13x0x.VXD", 0,0,0,
                            CREATE_NEW, FILE_FLAG_DELETE_ON_CLOSE, 0);
    }
    if (hDriver == INVALID_HANDLE_VALUE)
        return -1;
    /*
    ** From now on, the code is common for Win95 & WinNT
    **
    */
    if (physaddr == 0)
```

```
        return -1;
Arr[0] = physaddr;
Arr[1] = 4 * 1024 * 1024;
rc = DeviceIoControl(hDriver, IOCTL_SED_MAP_PHYSICAL_MEMORY,
                    &Arr[0], 2 * sizeof(ULONG), &retVal, sizeof(ULONG),
                    &cbReturned, NULL);
if (rc)
    *linaddr = retVal;

/*
** Close the handle.
** This will dynamically UNLOAD the Virtual Device for Win95.
*/
CloseHandle(hDriver);
if (rc)
    return 0;
return -1;
}
```

## 10.3 Header Files

The header files included here are the required for the HAL sample to compile correctly.

```
/*
**=====
** HAL.H - Header file for use with programs written to use the S1D13705 HAL.
**-----
** Created 1998, Vancouver Design Centre
** Copyright (c) 1998, 1999 Epson Research and Development, Inc.
** All Rights Reserved.
**=====
*/
#ifndef _HAL_H_
#define _HAL_H_
#include "hal_regs.h"
/*-----*/
typedef unsigned char  BYTE;
typedef unsigned short WORD;
typedef unsigned long  DWORD;
typedef unsigned int   UINT;
typedef          int    BOOL;
#ifdef INTEL
typedef BYTE  far *LPBYTE;
typedef WORD  far *LPWORD;
typedef UINT  far *LPUINT;
typedef DWORD far *LPDWORD;
#else
typedef BYTE      *LPBYTE;
typedef WORD      *LPWORD;
typedef UINT      *LPUINT;
typedef DWORD     *LPDWORD;
#endif
#ifndef LOBYTE
#define LOBYTE(w)    ((BYTE)(w))
#endif
#ifndef HIBYTE
#define HIBYTE(w)    ((BYTE)((((UINT)(w) >> 8) & 0xFF))
#endif
#ifndef LOWORD
#define LOWORD(l)    ((WORD)(DWORD)(l))
#endif
#ifndef HIWORD
#define HIWORD(l)    ((WORD)((((DWORD)(l) >> 16) & 0xFFFF))
#endif
#ifndef MAKEWORD
#define MAKEWORD(lo, hi) ((WORD)((((WORD)(lo)) | (((WORD)(hi)) << 8)) )
#endif
#ifndef MAKELONG
```

```

#define MAKELONG(lo, hi) (((long)(((WORD)(lo)) | (((DWORD)((WORD)(hi))) << 16)))
#endif
#ifndef TRUE
#define TRUE 1
#endif
#ifndef FALSE
#define FALSE 0
#endif
#define OFF 0
#define ON 1
#define SCREEN1 1
#define SCREEN2
/*
** Constants for HW rotate support
*/
#define DEFAULT0
#define LANDSCAPE 1
#define PORTRAIT2
#ifndef NULL
#ifdef __cplusplus
#define NULL 0
#else
#define NULL ((void *)0)
#endif
#endif
/*-----*/
/*
** SIZE_VERSION is the size of the version string (eg. "1.00")
** SIZE_STATUS is the size of the status string (eg. "b" for beta)
** SIZE_REVISION is the size of the status revision string (eg. "00")
*/
#define SIZE_VERSION5
#define SIZE_STATUS 2
#define SIZE_REVISION3
#ifdef ENABLE_DPF /* Debug_printf() */
#define DPF(exp) printf(#exp "\n")
#define DPF1(exp) printf(#exp " = %d\n", exp)
#define DPF2(exp1, exp2) printf(#exp1 "=%d " #exp2 "=%d\n", exp1, exp2)
#define DPF1L(exp) printf(#exp " = %x\n", exp)
#else
#define DPF(exp) ((void)0)
#define DPF1(exp) ((void)0)
#define DPF1L(exp) ((void)0)
#endif
/*-----*/
enum
{
ERR_OK = 0, /* No error, call was successful.
*/

```

```
ERR_FAILED,                                /* General purpose failure.
*/
ERR_UNKNOWN_DEVICE,                        /* */
ERR_INVALID_PARAMETER, /* Function was called with invalid parameter. */
ERR_HAL_BAD_ARG,
ERR_TOOMANY_DEVS
};
/*****
* Definitions for seGetId()
*****/
#define PRODUCT_ID 0x24
enum
{
    ID_UNKNOWN,
    ID_S1D13705_Rev1
};
#define MAX_MEM_ADDR81920 - 1
#define EIGHTY_K81920
#define MAX_DEVICE 10
#define SE_RSVD 0
/*****
* Definitions for Internal calculations.
*****/
#define MIN_NON_DISP_X 32
#define MAX_NON_DISP_X 256
#define MIN_NON_DISP_Y 2
#define MAX_NON_DISP_Y 64
enum
{
    RED,
    GREEN,
    BLUE
};
/*****
typedef struct tagHalStruct
{
    char  szIdString[16];
    WORD  wDetectEndian;
    WORD  wSize;
    BYTE  Reg[MAX_REG + 1];
    DWORD dwClkI;      /* Input Clock Frequency (in kHz) */
    DWORD dwDispMem; /* */
    WORD  wFrameRate; /* */
} HAL_STRUCT;
typedef HAL_STRUCT * PHAL_STRUCT;
#ifdef INTEL_16BIT
typedef HAL_STRUCT far * LPHAL_STRUCT;
#else
typedef HAL_STRUCT * LPHAL_STRUCT;
```

```

#endif
/*=====*/
/*          FUNCTION  PROTO-TYPES          */
/*=====*/
/*----- Initialization -----*/
int seRegisterDevice( const LPHAL_STRUCT lpHalInfo );
int seSetInit( void );
int seInitHal( void );
/*----- Miscellaneous -----*/
int seGetId( int *pId );
void seGetHalVersion( const char **pVersion, const char **pStatus,
                     const char **pStatusRevision );
int seSetBitsPerPixel( int nBitsPerPixel );
int seGetBitsPerPixel( int *pBitsPerPixel );
int seGetBytesPerScanline( int *pBytes );
int seGetScreenSize( int *width, int *height );
void seDelay( int nMilliseconds );
int seGetLastUsableByte( long *LastByte );
int seSetHighPerformance( BOOL OnOff );
/*----- Advanced -----*/
int seSetHWRotate( int nMode );
int seSplitInit( WORD Scrn1Addr, WORD Scrn2Addr );
int seSplitScreen( int WhichScreen, int VisibleScanlines );
int seVirtInit( int xVirt, long *yVirt );
int seVirtMove( int nWhichScreen, int x, int y );
/*----- Register/Memory Access -----*/
int seGetReg( int index, BYTE *pValue );
int seSetReg( int index, BYTE value );
int seReadDisplayByte( DWORD offset, BYTE *pByte );
int seReadDisplayWord( DWORD offset, WORD *pWord );
int seReadDisplayDword( DWORD offset, DWORD *pDword );
int seWriteDisplayBytes( DWORD addr, BYTE val, DWORD count );
int seWriteDisplayWords( DWORD addr, WORD val, DWORD count );
int seWriteDisplayDwords( DWORD addr, DWORD val, DWORD count );
/*----- Power Save -----*/
int seHWSuspend( int nDevID, BOOL val );
int seSetPowerSaveMode( int nDevID, int PowerSaveMode );
/*----- Drawing -----*/
int seDrawLine( int x1, int y1, int x2, int y2, DWORD color );
int seDrawRect( int x1, int y1, int x2, int y2, DWORD color, BOOL Solidfill );
/*----- Color -----*/
int seSetLut( BYTE *pLut );
int seGetLut( BYTE *pLut );
int seSetLutEntry( int index, BYTE *pEntry );
int seGetLutEntry( int index, BYTE *pEntry );
#endif      /* _HAL_H_ */

```

```

/*
**=====
** APPCFG.H - Application configuration information.
**-----
** Created 1998 - Vancouver Design Centre
** Copyright (c) 1998, 1999 Epson Research and Development, Inc.
** All Rights Reserved.
**-----
**
** The data in this file was generated using 13705CFG.EXE.
**
** The configuration parameters chosen were:
**   320x240 Single Color 4-bit STN
**   4 bpp - 100 Hz Frame Rate (12 MHz CLKi)
**   High Performance enabled
**
**=====
*/
/*****
/* 13705 HAL HDR          (do not remove)          */
/* HAL_STRUCT Information generated by 13705CFG.EXE */
/* Copyright (c) 1998 Epson Research and Development, Inc. */
/* All rights reserved.          */
/*          */
/* Include this file ONCE in your primary source file */
/*****
HAL_STRUCT HalInfo =
{
    "13705 HAL EXE",      /* ID string */
    0x1234,              /* Detect Endian */
    sizeof(HAL_STRUCT), /* Size */
    0x00, 0x20, 0xC0, 0x03, 0x27, 0xEF, 0x00, 0x00,
    0x00, 0x00, 0x03, 0x00, 0x00, 0x00, 0x00, 0x00,
    0x00, 0x00, 0xFF, 0x03, 0x00, 0x00, 0x00, 0x00,
    0x00, 0x00, 0x00, 0x00, 0x00, 0x00, 0x00, 0x00,
    6000,                /* ClkI (kHz) */
    0xF00000,           /* Display Address */
    70,                 /* Panel Frame Rate (Hz) */
};

```

```

/*
**=====
**  HAL_REGS.H
**-----
**  Created 1998, Epson Research & Development
**          Vancouver Design Center.
**  Copyright(c) Seiko Epson Corp. 1998.  All rights reserved.
**=====
*/
#ifndef __HAL_REGS_H__
#define __HAL_REGS_H__
/*
**      13705 register names
*/
#define REG_REVISION_CODE           0x00
#define REG_MODE_REGISTER_0        0x01
#define REG_MODE_REGISTER_1        0x02
#define REG_MODE_REGISTER_2        0x03
#define REG_HORZ_PANEL_SIZE         0x04
#define REG_VERT_PANEL_SIZE_LSB     0x05
#define REG_VERT_PANEL_SIZE_MSB     0x06
#define REG_FPLINE_START_POS        0x07
#define REG_HORZ_NONDISP_PERIOD     0x08
#define REG_FPFRAME_START_POS       0x09
#define REG_VERT_NONDISP_PERIOD     0x0A
#define REG_MOD_RATE                 0x0B
#define REG_SCRN1_START_ADDR_LSB    0x0C
#define REG_SCRN1_START_ADDR_MSB    0x0D
#define REG_SCRN2_START_ADDR_LSB    0x0E
#define REG_SCRN2_START_ADDR_MSB    0x0F
#define REG_SCRN_START_ADDR_OVERFLOW 0x10
#define REG_MEMORY_ADDR_OFFSET      0x11
#define REG_SCRN1_VERT_SIZE_LSB     0x12
#define REG_SCRN1_VERT_SIZE_MSB     0x13
#define REG_LUT_ADDR                 0x15
#define REG_LUT_BANK_SELECT         0x16
#define REG_LUT_DATA                 0x17
#define REG_GPIO_CONFIG              0x18
#define REG_GPIO_STATUS              0x19
#define REG_SCRATCHPAD               0x1A
#define REG_PORTRAIT_MODE            0x1B
#define REG_LINE_BYTE_COUNT          0x1C
#define REG_NOT_PRESENT_1           0x1D
/*
** WARNING!!! MAX_REG must be the last available register!!!
*/
#define MAX_REG                      0x1D
#endif /* __HAL_REGS_H__ */

```



```
/*-----  
**  
** Copyright (c) 1998, 1999 Epson Research and Development, Inc.  
** All Rights Reserved.  
**  
** Module Name:  
**  
**     ioctl.h  
**  
**  
** Abstract:  
**  
**     Include file for S1D13x0x PCI Board Driver.  
**     Define the IOCTL codes we will use.  The IOCTL code contains a command  
**     identifier, plus other information about the device, the type of access  
**     with which the file must have been opened, and the type of buffering.  
**  
**-----  
*/  
  
#define SED_TYPE FILE_DEVICE_CONTROLLER  
// The IOCTL function codes from 0x800 to 0xFFF are for customer use.  
#define IOCTL_SED_QUERY_NUMBER_OF_PCI_BOARDS \  
    CTL_CODE( SED_TYPE, 0x900, METHOD_BUFFERED, FILE_ANY_ACCESS)  
#define IOCTL_SED_MAP_PCI_BOARD \  
    CTL_CODE( SED_TYPE, 0x901, METHOD_BUFFERED, FILE_ANY_ACCESS)  
#define IOCTL_SED_MAP_PHYSICAL_MEMORY \  
    CTL_CODE( SED_TYPE, 0x902, METHOD_BUFFERED, FILE_ANY_ACCESS)  
#define IOCTL_SED_UNMAP_LINEAR_MEMORY \  
    CTL_CODE( SED_TYPE, 0x903, METHOD_BUFFERED, FILE_ANY_ACCESS)
```

**THIS PAGE LEFT BLANK**

<b>REG[00h] REVISION CODE REGISTER</b> IO address = 1FEE0h, RO		Product Code = 001001		Revision Code = 00	
Bit 5	Bit 4	Bit 3	Bit 2	Bit 1	Bit 0
<b>REG[01h] MODE REGISTER 0</b> IO address = 1FEE1h, RW		FPFrame Polarity		Data Width 4	
TFT/STN REG[01] bit 0	Dual/Single	Color/Mono	FPFrame Polarity	Mask FPSHIFT	Bit 1
<b>REG[02h] MODE REGISTER 1</b> IO address = 1FEE2h, RW		Input Clock Performance Div (CLK/2)		Hw Video Invert Video Invert	
Bit 1	Bit 0	High 5 Performance	Div (CLK/2)	Frame Repeat	Enable
<b>REG[03h] MODE REGISTER 2</b> IO address = 1FEE3h, RW		LCDPWR Override		Sw Power Save 6	
n/a	n/a	n/a	n/a	Hardware PS Enable	Bit 1
<b>REG[04h] HORIZONTAL PANEL SIZE REGISTER</b> IO address = 1FEE4h, RW		Horizontal Panel Size = 8(REG + 1)		Vertical Panel Size	
n/a	Bit 6	Bit 5	Bit 4	Bit 3	Bit 2
<b>REG[05h] VERTICAL PANEL SIZE REGISTER (LSB)</b> IO address = 1FEE5h, RW		Vertical Panel Size = (REG[05h], REG[06h]) + 1		Vertical Panel Size	
Bit 7	Bit 6	Bit 5	Bit 4	Bit 3	Bit 2
<b>REG[06h] VERTICAL PANEL SIZE REGISTER (MSB)</b> IO address = 1FEE6h, RW		IO address = 1FEE6h, RW		Vertical Panel Size	
n/a	n/a	n/a	n/a	n/a	Bit 1
<b>REG[07h] FPLINE START POSITION</b> IO address = 1FEE7h, RW		FPLine Start Position = 8(REG[07h] + 2)		Bit 0	
n/a	n/a	n/a	Bit 4	Bit 3	Bit 2
<b>REG[08h] HORIZONTAL NON-DISPLAY PERIOD</b> IO address = 1FEE8h, RW		Horizontal Non-Display Period = 8(REG + 4)		Bit 0	
n/a	n/a	n/a	Bit 4	Bit 3	Bit 2
<b>REG[09h] FPPFRAME START POSITION</b> IO address = 1FEE9h, RW		FPPFrame Start Position		Bit 0	
n/a	n/a	Bit 5	Bit 4	Bit 3	Bit 2
<b>REG[0Ah] VERTICAL NON-DISPLAY PERIOD REGISTER</b> IO address = 1FEEAh, RW		Vertical Non-Display Period		Bit 0	
Vert Non-Disp Status	n/a	Bit 5	Bit 4	Bit 3	Bit 2
<b>REG[0Bh] MOD RATE REGISTER</b> IO address = 1FEEBh, RW		MOD Rate		Bit 0	
n/a	n/a	Bit 5	Bit 4	Bit 3	Bit 2
<b>REG[0Ch] SCREEN 1 START WORD ADDRESS REGISTER (LSB)</b> IO address = 1FEECh, RW		Screen 1 Start Word Address = (REG[0Ch], REG[0Dh], REG[0Eh]) bit 1		Bit 0	
Bit 7	Bit 6	Bit 5	Bit 4	Bit 3	Bit 2
<b>REG[0Dh] SCREEN 1 START WORD ADDRESS REGISTER (MSB)</b> IO address = 1FEECh, RW		Screen 1 Start Word Address		Bit 8	
Bit 15	Bit 14	Bit 13	Bit 12	Bit 11	Bit 10
<b>REG[0Eh] SCREEN 2 START WORD ADDRESS REGISTER (LSB)</b> IO address = 1FEEeh, RW		Screen 2 Start Word Address = (REG[0Eh], REG[0Fh], REG[10h]) bit 4		Bit 0	
Bit 7	Bit 6	Bit 5	Bit 4	Bit 3	Bit 2
<b>REG[0Fh] SCREEN 2 START WORD ADDRESS REGISTER (MSB)</b> IO address = 1FEEeh, RW		Screen 2 Start Word Address		Bit 8	
Bit 15	Bit 14	Bit 13	Bit 12	Bit 11	Bit 10
<b>REG[10h] SCREEN START ADDRESS OVERFLOW REGISTER</b> IO address = 1FEE0h, RW		Screen 1 Start Add		Screen 1 Start Add	
			Bit 16		Bit 16

<b>REG[11h] MEMORY ADDRESS OFFSET REGISTER</b> IO address = 1FFF1h, RW		Memory Address Offset		Bit 0	
Bit 7	Bit 6	Bit 5	Bit 4	Bit 3	Bit 2
<b>REG[12h] SCREEN 1 VERTICAL SIZE REGISTER (LSB)</b> IO address = 1FFF2h, RW		Screen 1 Vertical Size = (REG[12h], REG[13h])		Bit 0	
Bit 7	Bit 6	Bit 5	Bit 4	Bit 3	Bit 2
<b>REG[13h] SCREEN 1 VERTICAL SIZE REGISTER (MSB)</b> IO address = 1FFF3h, RW		IO address = 1FFF3h, RW		Screen 1 Vertical Size	
n/a	n/a	n/a	n/a	n/a	Bit 8
<b>REG[14h] LOOK-UP TABLE ADDRESS REGISTER</b> IO address = 1FFF5h, RW		Look-Up Table Address		Bit 0	
Bit 7	Bit 6	Bit 5	Bit 4	Bit 3	Bit 2
<b>REG[17h] LOOK-UP TABLE DATA REGISTER</b> IO address = 1FFF7h, RW		Look-Up Table Data		n/a	
Bit 3	Bit 2	Bit 1	Bit 0	n/a	n/a
<b>REG[18h] GPIO CONFIGURATION CONTROL REGISTER</b> IO address = 1FFF8h, RW		GPIO1 Pin IO Config		GPIO0 Pin IO Config	
n/a	n/a	n/a	n/a	n/a	n/a
<b>REG[19h] GPIO STATUS / CONTROL REGISTER</b> IO address = 1FFF9h, RW		GPIO1 Pin IO Status		GPIO0 Pin IO Status	
n/a	n/a	n/a	n/a	n/a	n/a
<b>REG[1Ah] SCRATCH PAD REGISTER</b> IO address = 1FFFAh, RW		Scratch Pad Register		Bit 0	
Bit 7	Bit 6	Bit 5	Bit 4	Bit 3	Bit 2
<b>REG[1Bh] SWIVELVIEW MODE REGISTER</b> IO address = 1FFFbh, RW		SwivelView Mode Sel.		SwivelView POLK Select	
SwivelView Mode En.	n/a	n/a	n/a	n/a	Bit 1
<b>REG[1Ch] LINE BYTE COUNT REGISTER</b> IO address = 1FFFCh, RW		Line Byte Count		Bit 0	
Bit 7	Bit 6	Bit 5	Bit 4	Bit 3	Bit 2

Notes

- 1 These bits are used to identify the S1D13705 at power on / reset.
- 2 IO addresses are relative to the beginning of display memory.
- 3 Gray Shade/Color Mode Selection

<b>Color/Mono REG[01] bit 5</b>	<b>Bit-Per-Pixel REG[02] bit 7</b>	<b>Bit-Per-Pixel Bit 0 REG[02] bit 6</b>	<b>Display Mode</b>
1	0	0	2 Colors
0	1	0	4 Colors
0	0	1	16 Colors
0	0	0	256 Colors
0	0	1	2 Gray Shade
0	1	0	4 Gray Shade
0	1	1	16 Gray Shade
			reserved

<b>TFT/STN REG[01] bit 7</b>	<b>Color/Mono REG[01] bit 5</b>	<b>Dual/Single REG[01] bit 6</b>	<b>Data Width Bit REG[01] bit 1</b>	<b>Data Width Bit REG[01] bit 0</b>	<b>Function</b>
0	0	0	0	0	Mono Single 4-bit LCD
0	0	0	1	0	Mono Single 8-bit LCD
0	0	0	1	1	reserved
0	0	0	0	0	reserved
0	0	0	1	1	Mono Dual 8-bit LCD
0	0	0	1	0	reserved
0	0	0	1	1	reserved
0	0	0	0	0	Color Single 4-bit LCD
0	0	0	1	1	Color Single 8-bit LCD Format 1
0	0	0	1	0	reserved
0	0	0	1	1	Color Single 8-bit LCD Format 2
0	0	0	1	0	reserved
0	0	0	1	1	Color Dual 8-bit LCD
0	0	0	1	0	reserved
0	0	0	1	1	reserved
1	1	1	1	1	9 bit TFT Panel
1	1	1	1	1	12 bit TFT Panel

5 High Performance Selection

<b>High Performance</b>	<b>Bit-Per-Pixel REG[02] bit 7</b>	<b>Bit-Per-Pixel Bit 0 REG[02] bit 6</b>	<b>Display Modes</b>
0	0	0	MCK = PCK/8 1 bit-per-pixel
0	1	0	MCK = PCK/4 2 bit-per-pixel
0	0	1	MCK = PCK/2 4 bit-per-pixel
0	1	1	MCK = PCK 8 bit-per-pixel
1	X	X	MCK = PCK

6 Power Save Mode Selection

<b>Power Save Bit 1</b>	<b>Power Save Bit 0</b>	<b>Mode</b>
0	0	Power Save Mode 1
0	1	reserved
1	0	reserved
1	1	Normal Operation

4 Panel Data Format





## **S1D13705 Embedded Memory LCD Controller**

# **13705CFG Configuration Program**

**Document Number: X27A-B-001-03**

Copyright © 1999, 2002 Epson Research and Development, Inc. All Rights Reserved.

Information in this document is subject to change without notice. You may download and use this document, but only for your own use in evaluating Seiko Epson/EPSON products. You may not modify the document. Epson Research and Development, Inc. disclaims any representation that the contents of this document are accurate or current. The Programs/Technologies described in this document may contain material protected under U.S. and/or International Patent laws.

EPSON is a registered trademark of Seiko Epson Corporation. Microsoft and Windows are registered trademarks of Microsoft Corporation. All other trademarks are the property of their respective owners.

---

**THIS PAGE LEFT BLANK**

# Table of Contents

<b>13705CFG</b> . . . . .	<b>5</b>
S1D13705 Supported Evaluation Platforms . . . . .	.5
Installation . . . . .	.6
Usage . . . . .	.6
13705CFG Configuration Tabs . . . . .	.7
General Tab . . . . .	.7
Preferences Tab . . . . .	.9
Clocks Tab . . . . .	10
Panel Tab . . . . .	12
Panel Power Tab . . . . .	16
Registers Tab . . . . .	17
13705CFG Menus . . . . .	18
Open... . . . .	18
Save . . . . .	19
Save As... . . . .	19
Configure Multiple . . . . .	20
Export . . . . .	21
Enable Tooltips . . . . .	22
ERD on the Web . . . . .	22
About 13705CFG . . . . .	22
Comments . . . . .	22

**THIS PAGE LEFT BLANK**



# 13705CFG

13705CFG is an interactive Windows® program that calculates register values for a user-defined S1D13705 configuration. The configuration information can be used to directly alter the operating characteristics of the S1D13705 utilities or any program built with the Hardware Abstraction Layer (HAL) library. Alternatively, the configuration information can be saved in a variety of text file formats for use in other applications.

## Note

This program is a Windows desktop application suitable for configuring software for a given implementation of an Epson LCD controller. However, it is not a display driver for any Windows desktop operating system. Epson does not provide display drivers for any of the Windows desktop operating systems.

## S1D13705 Supported Evaluation Platforms

13705CFG runs on PC system running Windows 9x/ME/XP/NT/2000 and can modify Win32 .exe files.

## Installation

Create a directory for **13705cfg.exe** and the S1D13705 utilities. Copy the files **13705cfg.exe** and **panels.def** to that directory. **Panels.def** contains configuration information for a number of panels and must reside in the same directory as **13705cfg.exe**.

## Usage

To start 13705CFG from the Windows desktop, double-click on the My Computer icon and run the program **13705cfg.exe** from the installed directory.

To start 13705CFG from a Windows command prompt, change to the directory **13705cfg.exe** was installed to and type the command **13705cfg**.

The basic procedure for using 13705CFG is:

1. Start 13705CFG as described above.
2. Open an existing file to serve as a starting reference point (this step is optional).
3. Modify the configuration. For specific information on editing the configuration, see “13705CFG Configuration Tabs” on page 7.
4. Save the new configuration. The configuration information can be saved in two ways; as an ASCII text file or by modifying an executable image on disk.

Several ASCII text file formats are supported. Most are formatted C header files used to build display drivers or standalone applications.

Utility files based on the Hardware Abstraction Layer (HAL) can be modified directly by 13705CFG.

## 13705CFG Configuration Tabs

13705CFG provides a series of tabs which can be selected at the top of the main window. Each tab allows the configuration of a specific aspect of S1D13705 operation.

The tabs are labeled “General”, “Preference”, “Clocks”, “Panel”, “Panel Power”, and “Registers”. The following sections describe the purpose and use of each of the tabs.

### General Tab

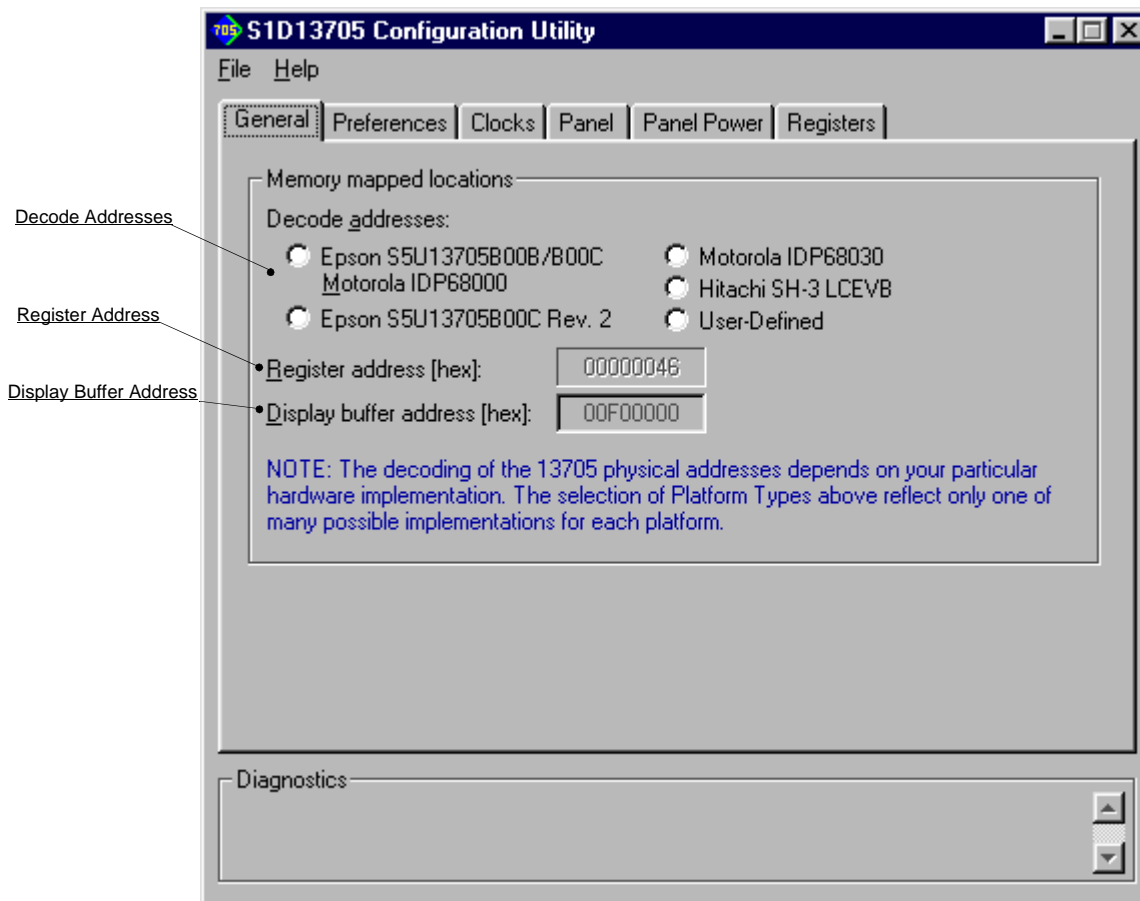

The General tab contains S1D13705 evaluation board specific information. The values presented are used for configuring HAL based executable utilities. The settings on this tab specify where in CPU address space the registers and display buffer are located.

---

Decode Addresses	Selecting one of the listed evaluation platforms changes the values for the “Register address” and “Display buffer address” fields. The values used for each evaluation platform are examples of possible implementations as used by the Epson S1D13705 evaluation board. If your hardware implementation differs from the addresses used, select the User-Defined option and enter the correct addresses for “Register address” and “Display buffer address”.
Register Address	<p>The physical address of the start of register decode space (in hexadecimal).</p> <p>This field is automatically set according to the Decode Address unless the “User-Defined” decode address is selected.</p>
Display Buffer Address	<p>The physical address of the start of display buffer decode space (in hexadecimal).</p> <p>This field is automatically set according to the Decode Address unless the “User-Defined” decode address is selected.</p>

**Note**

When “Epson S5U13705B00C Rev. 2 Evaluation Board” is selected, the register and display buffer addresses are blanked because the evaluation board uses the PCI interface and the decode addresses are determined by the system BIOS during boot-up.

If using the S1D13705 Evaluation Board on a PCI based platform, both Windows and the S1D13XXX device driver must be installed. For further information on the S1D13XXX device driver, see the *S1D13XXX Windows 32-bit Windows Device Driver Installation Guide*, document number X00A-E-003-xx.

## Preferences Tab

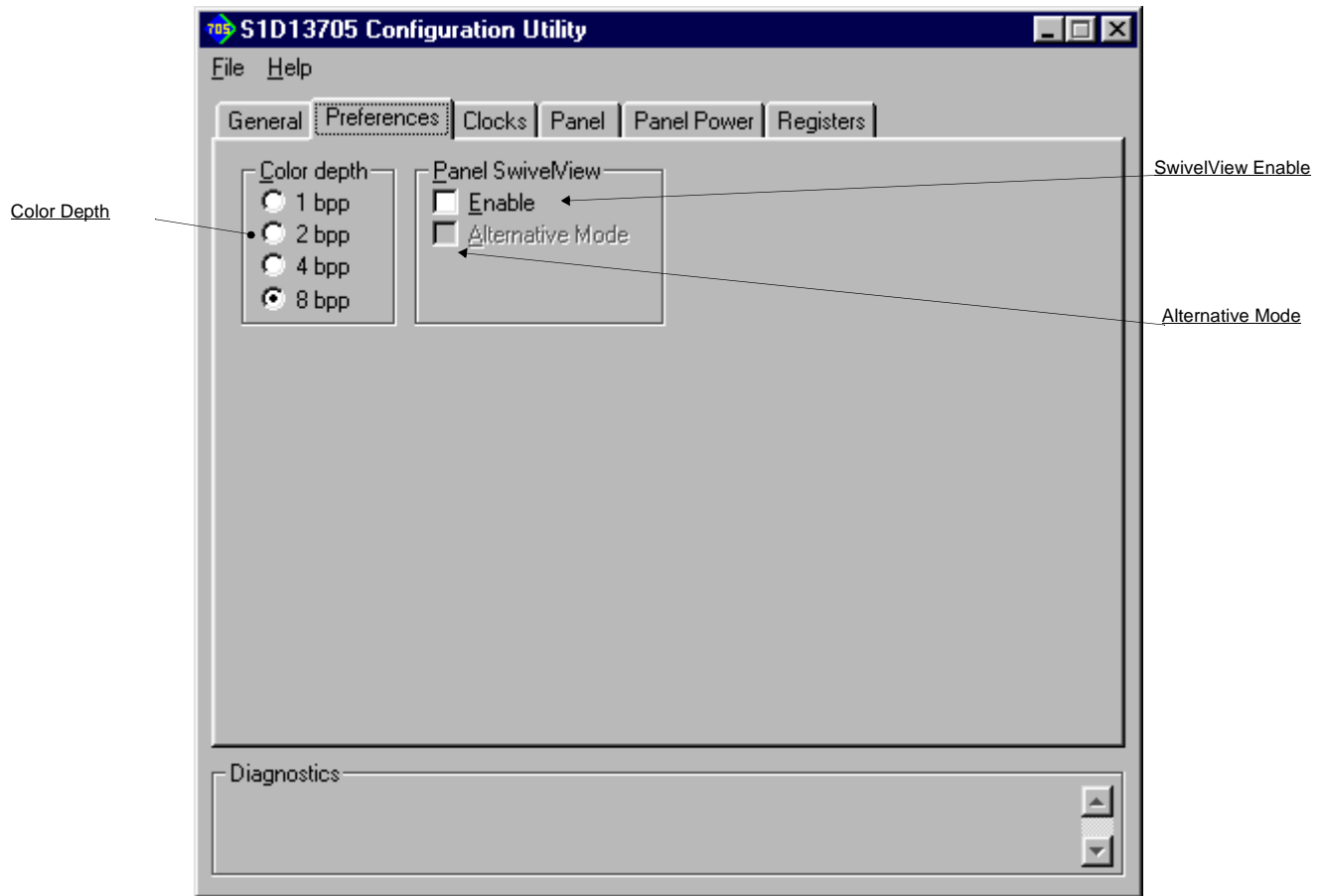

The Preference tab contains settings pertaining to the initial display state. During runtime these settings may be changed.

Color Depth

Sets the initial color depth on the LCD panel.

Panel SwivelView

The S1D13705 SwivelView feature is capable of rotating the image displayed on an LCD panel 90° in a counter-clockwise direction. This sets the initial orientation of the panel. The SwivelView feature can be run in two different modes. Default mode requires a virtual display which requires more memory but uses less power.

Enable

When this box is checked SwivelView is enabled and the LCD display is rotated 90° in a counter-clockwise direction.

## Alternative Mode

When alternate mode is selected, SwivelView requires no virtual display but consumes more power.

For details see the *S1D13705 Hardware Functional Specification*, document number X27A-A-001-xx.

## Clocks Tab

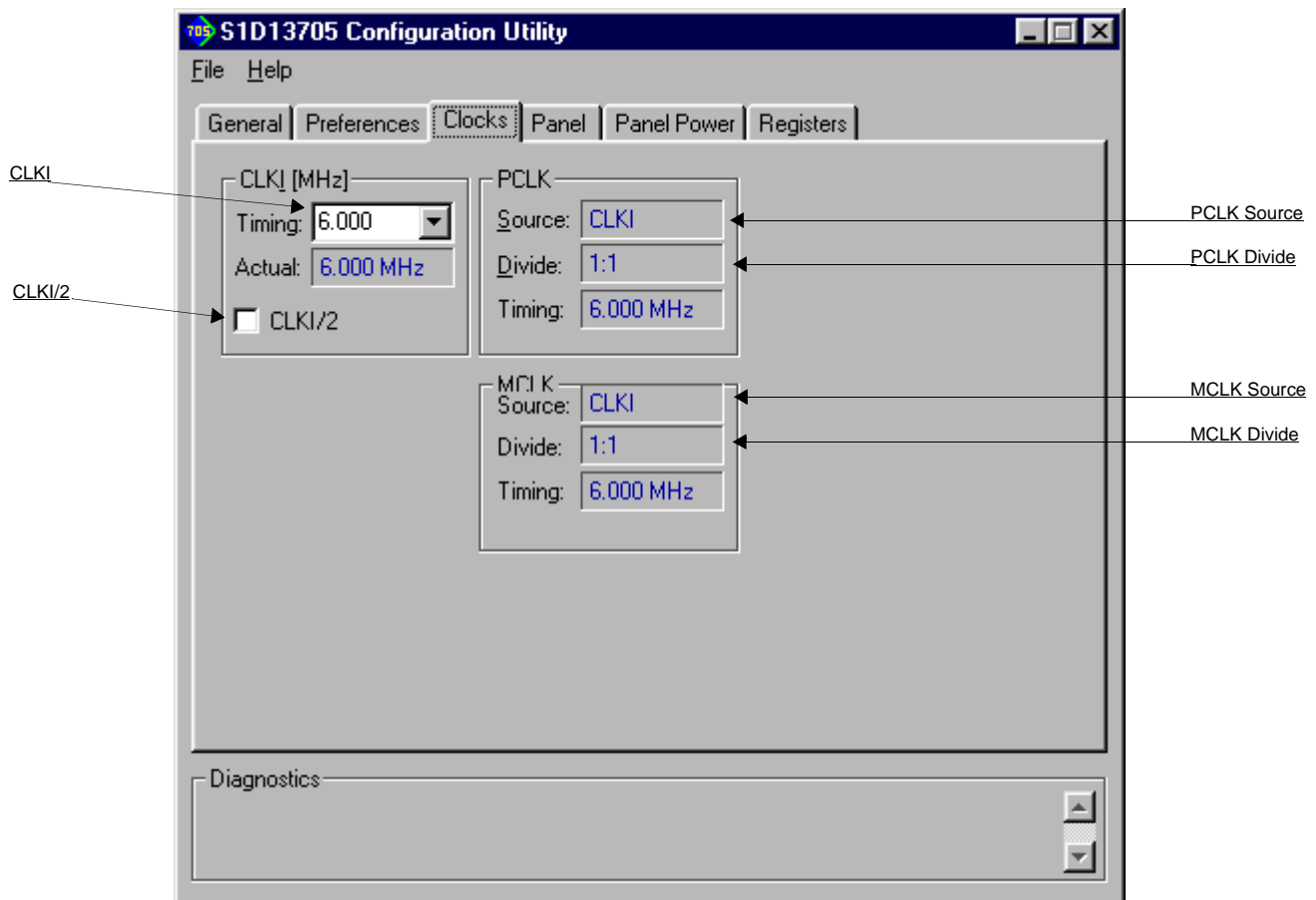

The Clocks tab is intended to simplify the selection of input clock frequencies and the source of internal clocking signals. For further information regarding clocking and clock sources, refer to the *S1D13705 Hardware Functional Specification*, document number X27A-A-001-xx.

**Note**

Options for LCD frame rates are limited to ranges determined by the clock values. Changing clock values may modify or invalidate Panel settings. Confirm all settings on the Panel tab after modifying any clock settings.

The S1D13705 uses one clock input known as CLKI. The pixel clock (PCLK) and the memory clock (MCLK) are both derived from CLKI.

**CLKI** This setting determines the frequency of CLKI. CLKI is the source for both PCLK and MCLK.

The CLKI frequency must be selected from the drop down list or by entering the desired frequency in MHz. The actual CLKI frequency used for configuration is displayed in blue in the Actual section.

CLKI/2 Selecting this box divides the input clock, CLKI, in half for internal S1D13705 operations.

**PCLK** These settings confirm the signal source and input clock divisor for the pixel clock (PCLK).

Source The PCLK source is CLKI.

Divide The divide ratio for the clock source signal is 1:1.

Timing This field shows the actual PCLK used by the configuration process.

**MCLK** These settings confirm the signal source and input clock divisor for the memory clock (MCLK).

Source The MCLK source is CLKI.

Divide The divide ratio for the clock source signal is 1:1.

Timing This field shows the actual MCLK frequency used by the configuration process.

## Panel Tab

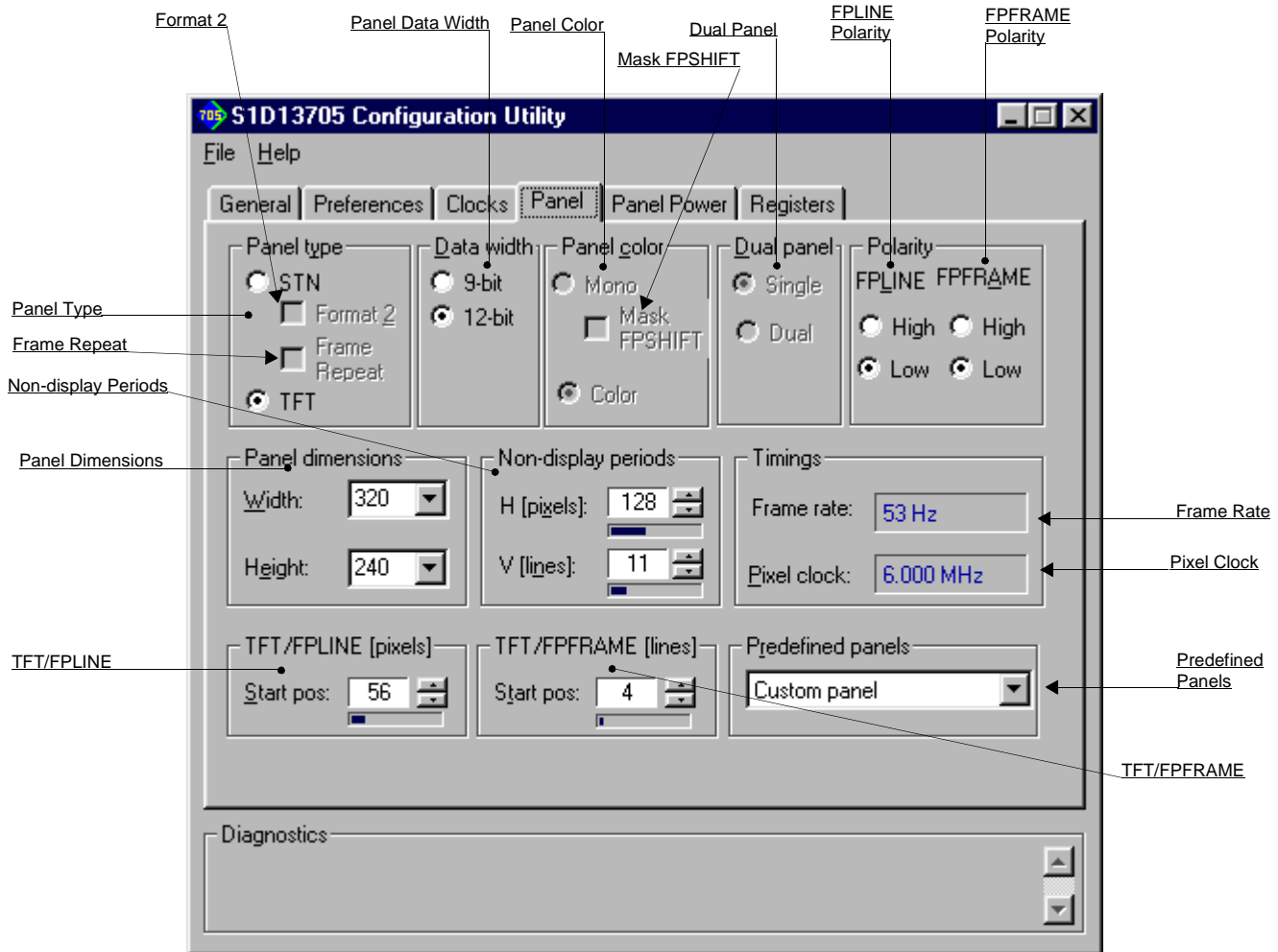

The S1D13705 supports many panel types. This tab allows configuration of most panel settings such as panel dimensions, type and timings.

### Panel Type

Selects between passive (STN) and active (TFT/D-TFD) panel types. The Epson D-TFD panels are supported only in TFT compatible mode.

Several options may change or become unavailable when the STN/TFT setting is switched. Therefore, confirm all settings on this tab after the Panel Type is changed.



---

Format 2	Selects color STN panel format 2. This option is specifically for configuring 8-bit color STN panels.  See the <i>S1D13705 Hardware Functional Specification</i> , document number X27A-A-001-xx, for description of format 1 / format 2 data formats. Most new panels use the format 2 data format.
Frame Repeat	Selects Frame Repeat feature for use with EL panels.  See the <i>S1D13705 Hardware Functional Specification</i> , document number X27A-A-001-xx, for description of Frame Repeat.
<b>Data Width</b>	Selects the panel data width. Panel data width is the number of bits of data transferred to the LCD panel on each clock cycle and shouldn't be confused with color depth which determines the number of displayed colors.  When the panel type is STN, the available options are 4 and 8 bit. When an active panel type is selected the available options are 9 and 12 bit.
<b>Panel Color</b>	Selects between a monochrome or color panel.
Mask FPSHIFT	When selected causes the signal FPSHIFT to be masked. When color or TFT panel is selected this option is disabled.
<b>Dual Panel</b>	Selects between single or dual panel.  When the panel type is TFT, "Single" is automatically selected and the "Dual" option is greyed out.
<b>Polarity</b>	These settings define the polarity of the FPLINE and FPFAME pulses.
FPLINE Polarity	Selects the polarity of the FPLINE pulse. Refer to the panel specification for the correct polarity of the FPLINE pulse.
FPFRAME Polarity	Selects the polarity of the FPFAME pulse. Refer to the panel specification for the correct polarity of the FPFAME pulse.

**Panel Dimensions**

These fields specify the panel width and height. A number of common widths and height are available in the selection boxes. If the width/height of your panel is not listed, enter the actual panel dimensions into the edit field.

Manually entered pixel widths must be multiples of 8. If a value is entered that does not match these requirements, a notification box appears and 13705CFG rounds up the value to the next allowable width.

**Non-Display Periods**

It is recommended that these automatically generated non-display values be used without adjustment. However, manual adjustment may be useful in fine tuning the non-display width and non-display height.

**Timings**

These settings show the Frame Rate and Pixel Clock timings.

## Frame Rate

This field displays the effective frame rate of the LCD panel. Panel dimensions are fixed therefore frame rate can only be adjusted by changing either PCLK or non-display period values. Higher frame rates correspond to smaller horizontal and vertical non-display values, or higher PCLK frequencies.

## Pixel Clock

The pixel clock used for the LCD panel is displayed in this field. The pixel clock is dependent on the CLKI frequency.

**TFT/FPLINE**

## Start Pos

Specifies the delay (in pixels) from the start of the horizontal non-display period to the leading edge of the FPLINE pulse. This setting is only available when the selected panel type is TFT.

Refer to *S1D13705 Hardware Functional Specification*, document number X27A-A-001-xx for a complete description of the FPLINE pulse settings.

---

## TFT/FPFRAME

### Start Pos

Specifies the delay (in lines) from the start of the vertical non-display period to the leading edge of the FPFRAME pulse. This settings is only available when the selected panel type is TFT.

Refer to *S1D13705 Hardware Functional Specification*, document number X27A-A-001-xx, for a complete description of the FPFRAME pulse settings.

## Predefined Panels

13705CFG uses a file (**panels.def**) which lists various panel manufacturers recommended settings. If the file **panels.def** is present in the same directory as **13705cfg.exe**, the settings for a number of predefined panels are available in the drop-down list. If a panel is selected from the list, 13705CFG loads the predefined settings contained in the file.

## Panel Power Tab

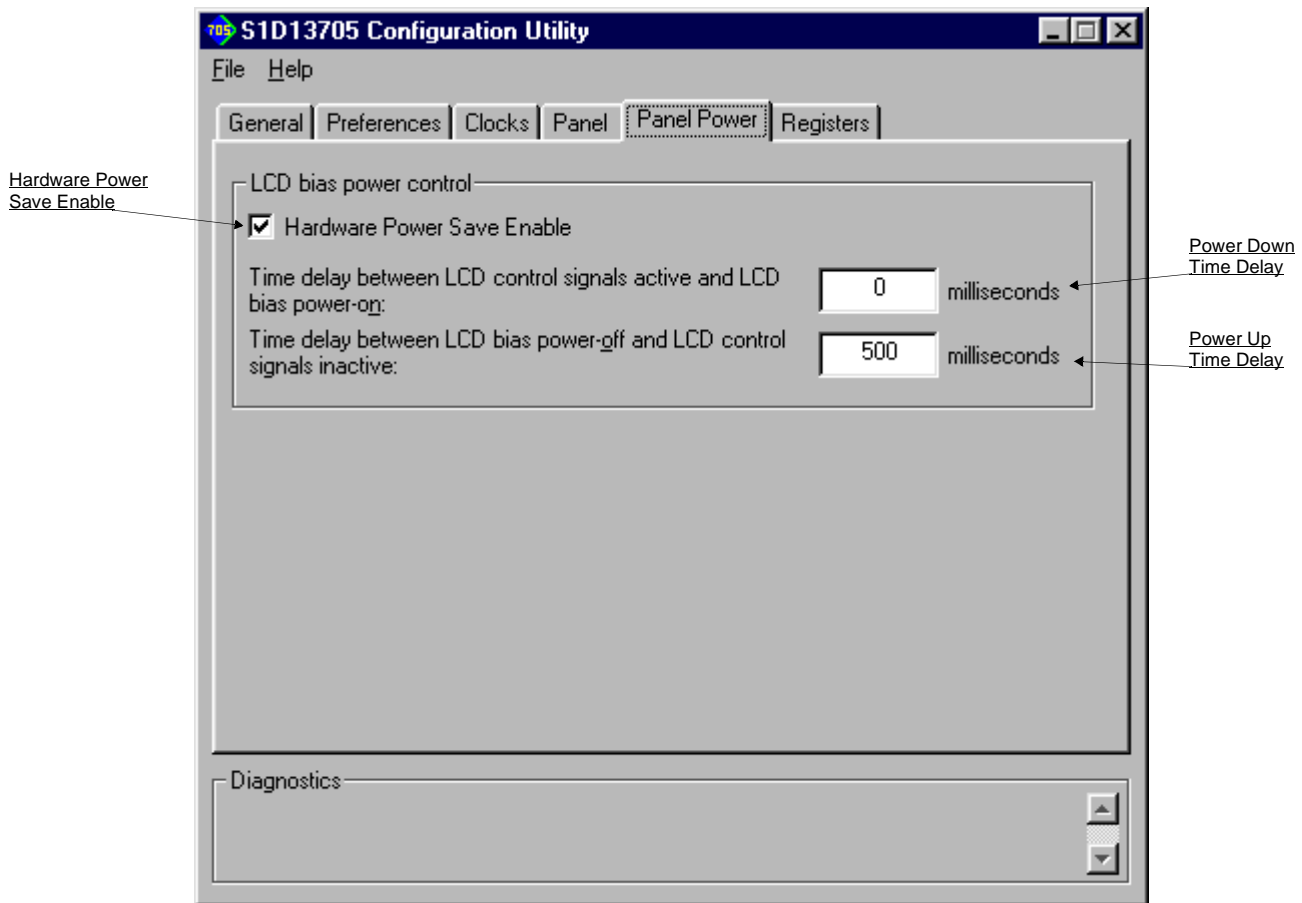

The S5U13705B00C evaluation board is designed to use the GPIO0 signal to control the LCD bias power. The following settings allow configuration of the necessary delays.

**Hardware Power Save Enable**      When this box is checked, Hardware Power Save using GPIO0 is enabled. When this box is unchecked, the Hardware Power Save function is not available.

**Power Down Time Delay**      This setting controls the time delay between when the LCD panel is powered-off and when the S1D13705 control signals are turned off. This setting must be configured according to the specification for the panel being used.

This value is only used by Epson evaluation software designed for the S5U13705B00C evaluation board.

Power Up Time Delay

This setting controls the time delay between when the S1D13705 control signals are turned on and the LCD panel is powered-on. This setting must be configured according to the specification for the panel being used.

This value is only used by Epson evaluation software designed for the S5U13705B00C evaluation board.

Registers Tab

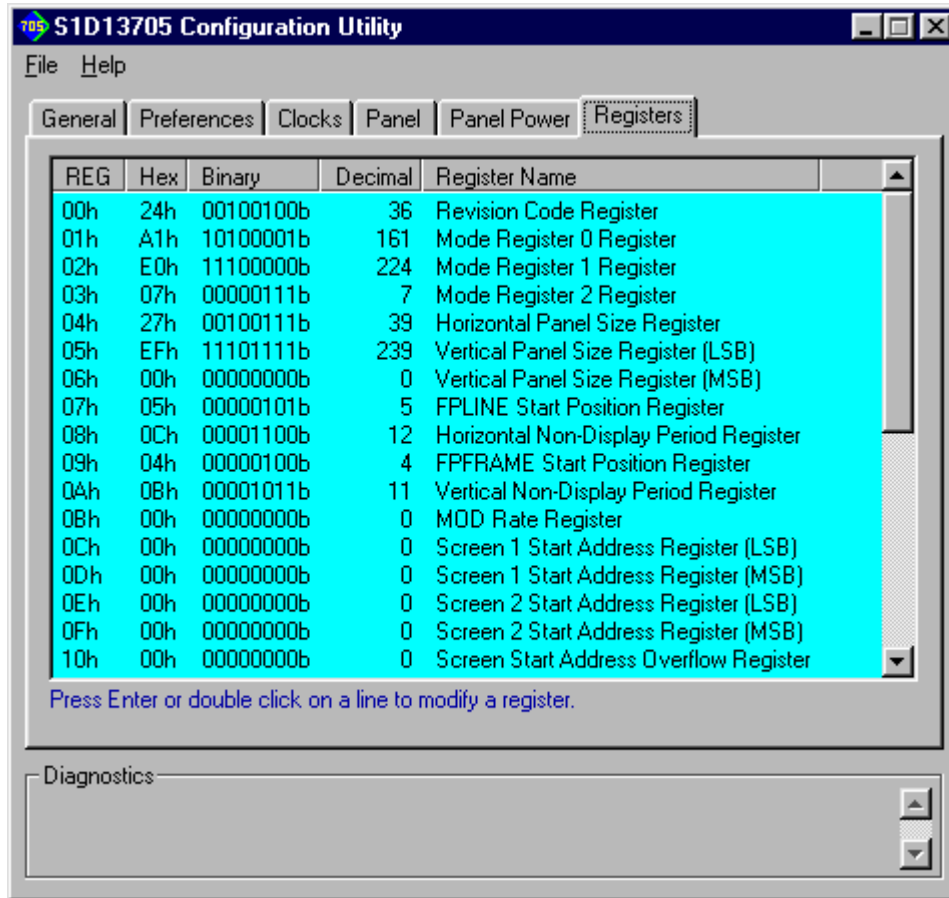

The Registers tab allows viewing and direct editing the S1D13705 register values.

Scroll up and down the list of registers and view their configured values based on the settings in the previous tabs. Individual register settings may be changed by double-clicking on the register in the listing. **Manual changes to the registers are not checked for errors, so caution is warranted when directly editing these values.** It is strongly recommended that the *S1D13705 Hardware Functional Specification*, document number X27A-A-001-xx be referred to before making a manual register settings.

Manually entered values may be changed by 13705CFG if further configuration changes are made on the other tabs. In this case, the user is notified.

**Note**

Manual changes to the registers may have unpredictable results if incorrect values are entered.

## 13705CFG Menus

The following sections describe each of the options in the File and Help menus.

### Open...

From the Menu Bar, select “File”, then “Open...” to display the Open File Dialog Box.

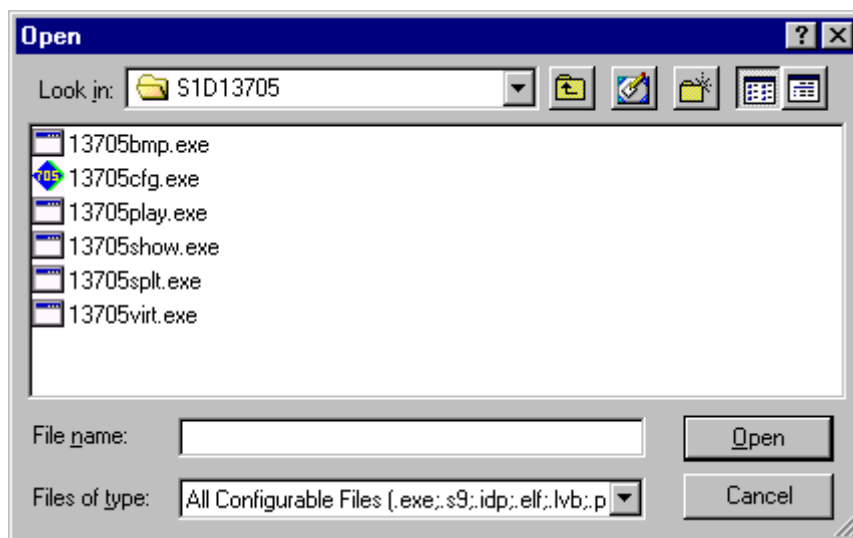

The Open option allows 13705CFG to open files containing HAL configuration information. When 13705CFG opens a file it scans the file for an identification string, and if found, reads the configuration information. This may be used to quickly arrive at a starting point for register configuration. The only requirement is that the file being opened must contain a valid S1D13705 HAL library information block.

13705CFG supports a variety of executable file formats. Select the file type(s) 13705CFG should display in the Files of Type drop-down list and then select the filename from the list and click on the Open button.

**Note**

13705CFG is designed to work with utilities programmed using a given version of the HAL. If the configuration structure contained in the executable file differs from the version 13705CFG expects the Open will fail and an error message is displayed. This may happen if the version of 13705CFG is substantially older, or newer, than the file being opened.

## Save

From the Menu Bar, select “File”, then “Save” to initiate the save action. The Save menu option allows a fast save of the configuration information to a file that was opened with the Open menu option.

### Note

This option is only available once a file has been opened.

### Note

**13705cfg.exe** can be configured by making a copy of the file 13705cfg.exe and configuring the copy. It is not possible to configure the original while it is running.

## Save As...

From the Menu Bar, select “File”, then “Save As...” to display the Save As Dialog Box.

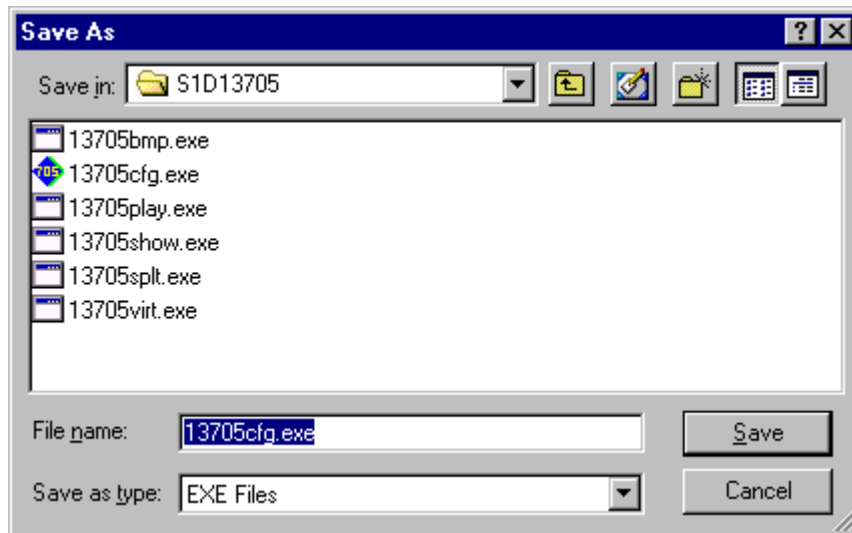

“Save as” is very similar to Save except a dialog box is displayed allowing the user to name the file before saving.

Using this technique a tester can configure a number of files differing only in configuration information and name (e.g. BMP60Hz.EXE, BMP72Hz.EXE, BMP75Hz.EXE where only the frame rate changes in each of these files).

### Note

When “Save As” is selected then an exact duplicate of the file as opened by the “Open” option is created containing the new configuration information.

## Configure Multiple

After determining the desired configuration, “Configure Multiple” allows the information to be saved into one or more executable files built with the HAL library.

From the Menu Bar, select “File”, then “Configure Multiple” to display the Configure Multiple Dialog Box. This dialog box is also displayed when a file(s) is dragged onto the 13705CFG window.

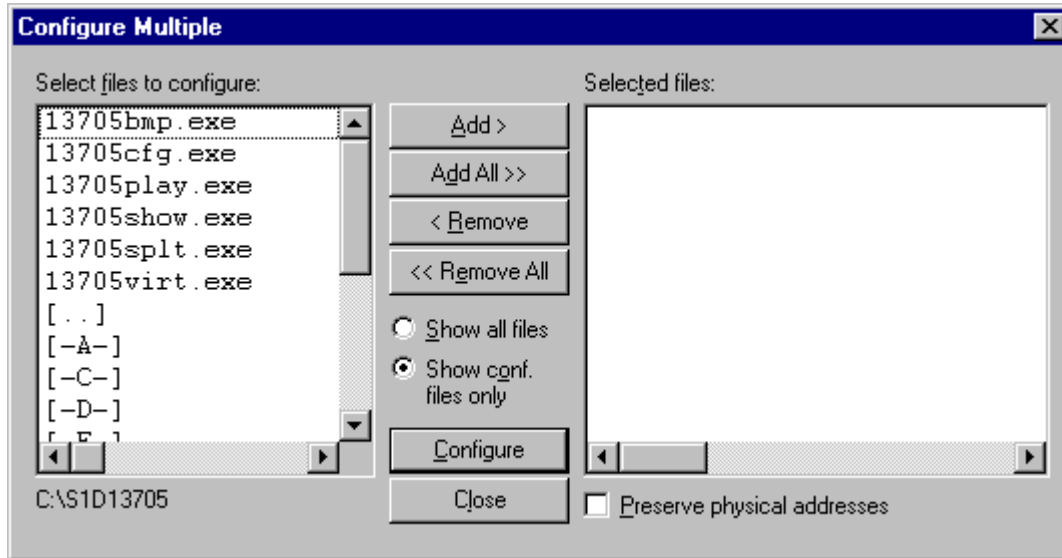

The left pane lists files available for configuration; the right pane lists files that have been selected for configuration. Files can be selected by clicking the “Add” or “Add All” buttons, double clicking any file in the left pane, or by dragging the file(s) from Windows Explorer.

Selecting “Show all files” displays all files in the selected directory, whereas selecting “Show conf. files only” will display only files that can be configured using 13705CFG.

The configuration values can be saved only to specific files. The file must have been compiled using the 13705 HAL library.

Checking “Preserve Physical Addresses” instructs 13705CFG to use the register and display buffer address values the files were previously configured with. Addresses specified in the General Tab are discarded. This is useful when configuring several programs for various hardware platforms at the same time. For example, if configuring PCI, MPC and IDP based programs at the same time for a new panel type, the physical addresses for each are retained. This feature is primarily intended for the test lab where multiple hardware configurations exist and are being tested.



## Export

After determining the desired configuration, “Export” permits the user to save the register information as a variety of ASCII text file formats. The following is a list and description of the currently supported output formats:

- a C header file for use in writing HAL library based applications.
- a C header file which lists each register and the value it should be set to.
- a C header file for use in developing Window CE display drivers.
- a C header file for use in developing display drivers for other operating systems such as Linux, QNX, and VxWorks UGL or WindML.
- a comma delimited text file containing an offset, a value, and a description for each S1D13705 register.

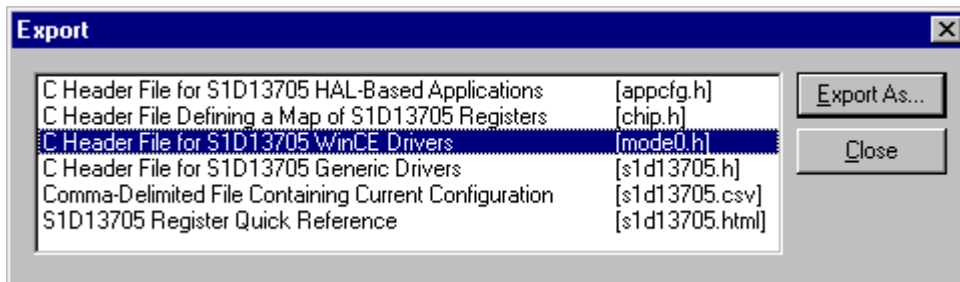

After selecting the file format, click the “Export As...” button to display the file dialog box which allows the user to enter a filename before saving. Before saving the configuration file, clicking the “Preview” button starts Notepad with a copy of the configuration file about to be saved.

When the **C Header File for S1D13705 WinCE Drivers** option is selected as the export type, additional options are available and can be selected by clicking on the Options button. The options dialog appears as:

**Mode Number**  
selects the mode number for  
use in the header file

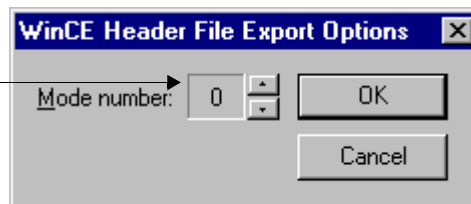

## Enable Tooltips

Tooltips provide useful information about many of the items on the configuration tabs. Placing the mouse pointer over nearly any item on any tab generates a popup window containing helpful advice and hints.

To enable/disable tooltips check/uncheck the “Tooltips” option from the “Help” menu.

### Note

Tooltips are enabled by default.

## ERD on the Web

This “Help” menu item is actually a hotlink to the Epson Research and Development website. Selecting “Help” then “ERD on the Web” starts the default web browser and points it to the ERD product web site.

The latest software, drivers, and documentation for the S1D13705 is available at this website.

## About 13705CFG

Selecting the “About 13705CFG” option from the “Help” menu displays the about dialog box for 13705CFG. The about dialog box contains version information and the copyright notice for 13705CFG.

## Comments

- On any tab particular options may be grayed out if selecting them would violate the operational specification of the S1D13705 (i.e. Selecting TFT or STN on the Panel tab enables/disables options specific to the panel type).
- The file **panels.def** is a text file containing operational specifications for several supported, and tested, panels. This file can be edited with any text editor.
- 13705CFG allows manually altering register values. The manual changes may violate memory and LCD timings as specified in the *S1D13705 Hardware Functional Specification*, document number X27A-A-001-xx. If this is done, unpredictable results may occur. Epson Research and Development, Inc. does not assume liability for any damage done to the display device as a result of configuration errors.



## **S1D13705 Embedded Memory LCD Controller**

# **13705SHOW Demonstration Program**

**Document No. X27A-B-002-02**

Copyright © 2001 Epson Research and Development, Inc. All Rights Reserved.

Information in this document is subject to change without notice. You may download and use this document, but only for your own use in evaluating Seiko Epson/EPSON products. You may not modify the document. Epson Research and Development, Inc. disclaims any representation that the contents of this document are accurate or current. The Programs/Technologies described in this document may contain material protected under U.S. and/or International Patent laws.

EPSON is a registered trademark of Seiko Epson Corporation. All other Trademarks are the property of their respective owners

---

**THIS PAGE LEFT BLANK**

# 13705SHOW

13705SHOW is a program designed to demonstrate rudimentary display capabilities of the S1D13705. The display abilities are shown by drawing a pattern image to the video display at all supported color depths (1, 2, 4 and 8 bits-per-pixel)

The 13705SHOW display utility must be configured and/or compiled to work with your hardware platform. The program 13705CFG.EXE can be used to configure 13705SHOW. Consult the 13705CFG users guide, document number X27A-B-001-xx, for more information on configuring S1D13705 utilities.

This software is designed to work in both embedded and personal computer (PC) environments. For the embedded environment, it is assumed that the system has a means of downloading software from the PC to the target platform. Typically, this is done by serial communications. The PC uses a terminal program to send control commands and information to the target processor. Alternatively, the PC can program an EPROM, which is then placed in the target platform. Some target platforms can also communicate with the PC via a parallel port connection, or an Ethernet connection.

## S1D13705 Supported Evaluation Platforms

13705SHOW has been tested with the following S1D13705 supported evaluation platforms:

- PC system with an x86 processor. Both 16-bit and 32-bit code is supported.
- M68EC000IDP (Integrated Development Platform) board, revision 3.0, with a Motorola M68EC000 processor.
- SH3-LCEVB board, revision B, with an Hitachi SH-3 HD6417780 processor.

If the platform you are using is different from the above, please see the S1D13705 Programming Notes and Examples manual, document number X26A-G-002-xx.

## Installation

### PC Intel Platform

**For 16-Bit Program Version:** copy the file 13705SHOW.EXE to a directory that is in the DOS path on your hard drive.

**For 32-Bit Program Version:** install the 32-bit Windows device driver S1D13X0X.VXD as described in the S1D13X0X 32-Bit Windows Device Driver Installation Guide, document number X00A-E-003-xx. Copy the file 13705SHOW.EXE to a directory that is in the DOS path on your hard drive.

### Embedded Platform

Download the program 13705SHOW to the system.

## Usage

**PC platform:** at the prompt, type:

```
13705show [/a][b=n][/l][/p [/alt]][/vertical][/noinit][/?]
```

**Embedded platform:** execute **13705show** and at the prompt, type the command line argument(s).

Where:	/a	automatically cycle through all video modes.
	b=?	starts 13705SHOW at a user specified bit-per-pixel (bpp) level, where ? can be: 1, 2, 4, or 8.
	/l	set landscape mode.
	/p	set portrait mode.
	/alt	use alternate portrait mode
	/vertical	displays vertical line pattern.
	/update	continuously update display memory.
	/noinit	bypass register initialization and use values which are currently in the registers.
	/?	displays the help screen.

## Comments

- The /alt command line switch can only be used with the /p (portrait) mode switch. This switch will have no effect in landscape display modes.
- The Intel 32-bit version of 13705SHOW is designed to work under either Windows 9x or Windows NT. To install the 32-bit Windows device driver S1D13X0X.vxd see the S1D13X0X 32-Bit Windows Device Driver Installation Guide, document number X00A-E-003-xx.

The 16-bit version of the program runs under DOS with no DOS extenders. The lack of a DOS extender means that the 16-bit program can only be used on a hardware platform where the S1D13705 is addressed below 1MB.

## Program Messages

### **ERROR: Did not find a 13705 device.**

The HAL was unable to read the revision code register on the S1D13705. Ensure that the S1D13705 hardware is installed and that the hardware platform has been configured correctly. Also check that the display memory address has been configured correctly.

### **ERROR: Unable to locate/load S1D13XXX.VXD**

13705PLAY was unable to load a required driver. The file S1D13XXX.VXD should be located in x:\WINDOWS\SYSTEM or in x:\WINNT\SYSTEM. If the file is not there, install it as described in the S1D13XXX 32-Bit Windows Device Driver Installation Guide, document number X00A-E-003-xx.

### **ERROR: An IOCTL error occurred**

This message indicates an error at the IO control layer occurred. The usual cause for this is an incorrect hardware configuration.

### **ERROR: The HAL returned an unknown error**

This message should never be displayed, it indicates that 13705SHOW is unable to determine the cause of an error returned from the HAL.

### **ERROR: Could not initialize device**

The call to initialize the S1D13705 registers failed.

### **Not enough memory for www x hhh x bpp!!**

This message is printed if there is insufficient display memory to show a complete image with a width of www pixels, a height of hhh pixels and a color depth of bpp bit-per-pixel. In this case the mode is skipped and the next display mode is attempted.

**THIS PAGE LEFT BLANK**





## **S1D13705 Embedded Memory LCD Controller**

# **13705SPLT Display Utility**

**Document No. X27A-B-003-02**

Copyright © 2001 Epson Research and Development, Inc. All Rights Reserved.

Information in this document is subject to change without notice. You may download and use this document, but only for your own use in evaluating Seiko Epson/EPSON products. You may not modify the document. Epson Research and Development, Inc. disclaims any representation that the contents of this document are accurate or current. The Programs/Technologies described in this document may contain material protected under U.S. and/or International Patent laws.

EPSON is a registered trademark of Seiko Epson Corporation. All other Trademarks are the property of their respective owners

---

**THIS PAGE LEFT BLANK**

# 13705SPLT

13705SPLT demonstrates S1D13705 split screen capability by showing two different areas of display memory on the screen simultaneously.

Screen 1 memory is located at the start of the display buffer and is filled with horizontal bars. Screen 2 memory is located immediately after Screen 1 in the display buffer and is filled with vertical bars. On either user input or elapsed time, the line compare register value is changed to adjust the amount of display area taken up by each screen.

The 13705SPLT display utility must be configured and/or compiled to work with your hardware platform. The program 13705CFG.EXE can be used to configure 13705SPLT. Consult the 13705CFG users guide, document number X27A-B-001-xx, for more information on configuring S1D13705 utilities.

This software is designed to work in both embedded and personal computer (PC) environments. For the embedded environment, it is assumed that the system has a means of downloading software from the PC to the target platform. Typically, this is done by serial communications. The PC uses a terminal program to send control commands and information to the target processor. Alternatively, the PC can program an EPROM, which is then placed in the target platform. Some target platforms can also communicate with the PC via a parallel port connection, or an Ethernet connection.

## S1D13705 Supported Evaluation Platforms

13705SPLT has been tested with the following S1D13705 supported evaluation platforms:

- PC system with an x86 processor. Both 16-bit and 32-bit code is supported.
- M68EC000IDP (Integrated Development Platform) board, revision 3.0, with a Motorola M68EC000 processor.
- SH3-LCEVB board, revision B, with an Hitachi SH-3 HD6417780 processor.

If the platform you are using is different from the above, please see the S1D13705 Programming Notes and Examples manual, document number X26A-G-002-xx.

## Installation

### PC Intel Platform

**For 16-Bit Program Version:** copy the file 13705SPLT.EXE to a directory that is in the DOS path on your hard drive.

**For 32-Bit Program Version:** install the 32-bit Windows device driver S1D13X0X.VXD as described in the S1D13X0X 32-Bit Windows Device Driver Installation Guide, document number X00A-E-003-xx. Copy the file 13705SPLT.EXE to a directory that is in the DOS path on your hard drive.

### Embedded Platform

Download the program 13705SPLT to the system.

## Usage

**PC platform:** at the prompt, type **13705SPLT [/a] [/?]**

**Embedded platform:** execute **13705spl1t** and at the prompt, type the command line argument.

Where:	no argument	enables manual split screen operation
	/a	enables automatic split screen operation (a timer is used to move screen 2)
	/?	display the help screen

After starting 13705SPLT the following keyboard commands are available.

Manual mode:	↑, u	move Screen 2 up
	↓, d	move Screen 2 down
	HOME	covers Screen 1 with Screen 2
	END	displays only Screen 1
Automatic mode:	any key	change the direction of split screen movement (for PC only)
Both modes:	b	changes the color depth (bits-per-pixel)
	ESC	exits 13705SPLT

## 13705SPLT Example

1. Type "13705spl /a" to automatically move the split screen.
2. Press "b" to change the color depth from 1 bit-per-pixel to 2 bit-per-pixel.
3. Repeat step 2 for the remaining color depths (4 and 8 bit-per-pixel).
4. Press <ESC> to exit the program.

## Program Messages

**ERROR: Did not find a 13705 device.**

The HAL was unable to read the revision code register on the S1D13705. Ensure that the S1D13705 hardware is installed and that the hardware platform has been configured correctly. Also check that the display memory address has been configured correctly.

**ERROR: Unable to locate/load S1D13XXX.VXD**

13705PLAY was unable to load a required driver. The file S1D13XXX.VXD should be located in x:\WINDOWS\SYSTEM or in x:\WINNT\SYSTEM. If the file is not there, install it as described in the S1D13XXX 32-Bit Windows Device Driver Installation Guide, document number X00A-E-003-xx.

**ERROR: An IOCTL error occurred**

This message indicates an error at the IO control layer occurred. The usual cause for this is an incorrect hardware configuration.

**ERROR: The HAL returned an unknown error**

This message should never be displayed, it indicates that 13705SOLT is unable to determine the cause of an error returned from the HAL.

**Not enough memory for www x hhh x bpp!!**

This message is displayed if there is insufficient display memory to contain two complete images with a width of www pixels, a height of hhh pixels, and a color depth of bpp bit-per-pixel. In this case the mode is skipped and the next display mode is attempted.

**THIS PAGE LEFT BLANK**



## **S1D13705 Embedded Memory LCD Controller**

# **13705VIRT Display Utility**

**Document No. X27A-B-004-02**

Copyright © 2001 Epson Research and Development, Inc. All Rights Reserved.

Information in this document is subject to change without notice. You may download and use this document, but only for your own use in evaluating Seiko Epson/EPSON products. You may not modify the document. Epson Research and Development, Inc. disclaims any representation that the contents of this document are accurate or current. The Programs/Technologies described in this document may contain material protected under U.S. and/or International Patent laws.

EPSON is a registered trademark of Seiko Epson Corporation. All other Trademarks are the property of their respective owners

---

**THIS PAGE LEFT BLANK**



# 13705VIRT

13705VIRT demonstrates the virtual display capability of the S1D13705. A virtual display is where the image to be displayed is larger than the physical display device. The display surface is used as a viewing window. The entire image can be seen only by panning and scrolling.

The 13705VIRT display utility must be configured and/or compiled to work with your hardware platform. The program 13705CFG.EXE can be used to configure 13705VIRT. Consult the 13705CFG users guide, document number X27A-B-001-xx, for more information on configuring S1D13705 utilities.

This software is designed to work in both embedded and personal computer (PC) environments. For the embedded environment, it is assumed that the system has a means of downloading software from the PC to the target platform. Typically, this is done by serial communications. The PC uses a terminal program to send control commands and information to the target processor. Alternatively, the PC can program an EPROM, which is then placed in the target platform. Some target platforms can also communicate with the PC via a parallel port connection, or an Ethernet connection.

## S1D13705 Supported Evaluation Platforms

13705VIRT has been tested with the following S1D13705 supported evaluation platforms:

- PC system with an x86 processor.
- M68EC000IDP (Integrated Development Platform) board, revision 3.0, with a Motorola M68EC000 processor.
- SH3-LCEVB board, revision B, with an Hitachi SH-3 HD6417780 processor.

If the platform you are using is different from the above, please see the S1D13705 Programming Notes and Examples manual, document number X26A-G-002-xx.

## Installation

### PC Intel Platform

**For 16-Bit Program Version:** copy the file 13705VIRT.EXE to a directory that is in the DOS path on your hard drive.

**For 32-Bit Program Version:** install the 32-bit Windows device driver S1D13X0X.VXD as described in the S1D13X0X 32-Bit Windows Device Driver Installation Guide, document number X00A-E-003-xx. Copy the file 13705VIRT.EXE to a directory that is in the DOS path on your hard drive.

### Embedded Platform

Download the program 13705VIRT to the system.

## Usage

**PC platform:** at the prompt, type `13705virt [/a] [/l] [/p] [/alt] [/w=???`].

**Embedded platform:** execute `13705virt` and at the prompt, type the command line argument.

Where:	no argument	panning and scrolling is performed manually (defaults to virtual width = physical width x 2 and maximum virtual height)
	/a	panning and scrolling is performed automatically
	/l	Force landscape display mode to be set
	/p	Force portrait display mode to be set
	/alt	Enable alternate portrait mode. Selecting this option implies /p
	/w=???	specifies the virtual display width which includes both on-screen and off-screen size
		the maximum virtual width, not including display area, for each display mode is:
		1 bpp – 4096 pixels
		2 bpp – 2048 pixels
		4 bpp – 1024 pixels
		8 bpp – 512 pixels

The following keyboard commands are for navigation within the program.

Manual mode:	↑	scrolls up
	↓	scrolls down
	←	pans to the left
	→	pans to the right
	HOME	moves the display screen so that the upper right of the virtual screen shows in the upper right of the display
	END	moves the display screen so that the lower left of the virtual screen shows in the lower left of the display
Automatic mode:	any key	changes the direction of screen
Both modes:	b	changes the color depth (bits-per-pixel)
	ESC	exits 13705VIRT

## 13705VIRT Example

1. Type "13705virt /a" to automatically pan and scroll.
2. Press "b" to change the bits-per-pixel from 1 bit-per-pixel to 2 bits-per-pixel.
3. Repeat steps 1 and 2 for the remaining color depths (4 and 8 bit-per-pixel).
4. Press <ESC> to exit the program.

## Program Messages

**ERROR: Did not find a 13705 device.**

The HAL was unable to read the revision code register on the S1D13705. Ensure that the S1D13705 hardware is installed and that the hardware platform has been configured correctly. Also check that the display memory address has been configured correctly.

**ERROR: Unable to locate/load S1D13XXX.VXD**

13705PLAY was unable to load a required driver. The file S1D13XXX.VXD should be located in x:\WINDOWS\SYSTEM or in x:\WINNT\SYSTEM. If the file is not there, install it as described in the S1D13XXX 32-Bit Windows Device Driver Installation Guide, document number X00A-E-003-xx.

**ERROR: An IOCTL error occurred**

This message indicates an error at the IO control layer occurred. The usual cause for this is an incorrect hardware configuration.

**ERROR: The HAL returned an unknown error**

This message should never be displayed, it indicates that 13705VIRT is unable to determine the cause of an error returned from the HAL.

**Unable to use virtual mode at xx BPP**

This message is displayed if there is insufficient display memory to show a complete virtual image. Specifically, the maximum number of lines for the image is calculated using the current virtual width. If the number of possible lines is less than the physical display size this message is displayed. Try restarting the program and manually specify a smaller virtual width.



## **S1D13705 Embedded Memory LCD Controller**

# **13705PLAY Diagnostic Utility**

**Document No. X27A-B-005-04**

Copyright © 2001 Epson Research and Development, Inc. All Rights Reserved.

Information in this document is subject to change without notice. You may download and use this document, but only for your own use in evaluating Seiko Epson/EPSON products. You may not modify the document. Epson Research and Development, Inc. disclaims any representation that the contents of this document are accurate or current. The Programs/Technologies described in this document may contain material protected under U.S. and/or International Patent laws.

EPSON is a registered trademark of Seiko Epson Corporation. All other Trademarks are the property of their respective owners

---

**THIS PAGE LEFT BLANK**

# 13705PLAY

13705PLAY is a utility which allows the user to easily read/write the S1D13705 registers, Look-Up Table and display memory.

The user interface for 13705PLAY is similar to the DOS DEBUG program; commands are received from the standard input device, and output is sent to the standard output device (console for Intel and terminal for embedded platforms). This utility requires the target platform to support standard IO.

13705PLAY commands can be entered interactively using a keyboard/monitor or they can be executed from a script file. Scripting is a powerful feature which allows command sequences played back from a file thus avoiding having to retype lengthy sequences.

The 13705PLAY display utility must be configured and/or compiled to work with your hardware platform. The program 13705CFG.EXE can be used to configure 13705PLAY. Consult the 13705CFG users guide, document number X27A-B-001-xx, for more information on configuring S1D13705 utilities.

This software is designed to work in both embedded and personal computer (PC) environments. For the embedded environment, it is assumed that the system has a means of downloading software from the PC to the target platform. Typically, this is done by serial communications. The PC uses a terminal program to send control commands and information to the target processor. Alternatively, the PC can program an EPROM, which is then placed in the target platform. Some target platforms can also communicate with the PC via a parallel port connection, or an Ethernet connection.

## S1D13705 Supported Evaluation Platforms

13705PLAY has been tested with the following S1D13705 supported evaluation platforms:

- PC system with an x86 processor. Both 16-bit and 32-bit code is supported.
- M68EC000IDP (Integrated Development Platform) board, revision 3.0, with a Motorola M68EC000 processor.
- SH3-LCEVB board, revision B, with an Hitachi SH-3 HD6417780 processor.

If the platform you are using is different from the above, please see the S1D13705 Programming Notes and Examples manual, document number X26A-G-002-xx.

## Installation

### PC Intel Platform

**For 16-Bit Program Version:** copy the file 13705PLAY.EXE to a directory that is in the DOS path on your hard drive.

**For 32-Bit Program Version:** install the 32-bit Windows device driver S1D13XXX.VXD as described in the S1D13XXX 32-Bit Windows Device Driver Installation Guide, document number X00A-E-003-xx. Copy the file 13705PLAY.EXE to a directory that is in the DOS path on your hard drive.

### Embedded Platform

Download the program 13705PLAY to the system.

## Usage

**PC platform:** at the prompt, type **13705play [/?]**.

**Embedded platform:** execute **13705play** and at the prompt, type the command line argument.

Where: **/?** displays program revision information.

The following commands are valid within the 13705PLAY program.

<code>x index [data]</code>	Reads/writes the registers.  Writes data to the register specified by the index when “data” is specified; otherwise the register is read.
<code>XA</code>	Reads all registers.
<code>L index [data1 data2 data3]</code>	Reads/writes Look-Up Table (LUT) values. Writes data to the LUT index when “data” is specified; otherwise the LUT index is read. Data must consist of 3 bytes: 1 red, 1 green, 1 blue. and range in value from 0x00 to 0x0F.
<code>LA</code>	Reads all LUT values.
<code>F[W] addr1 addr2 data . . .</code>	Fills bytes or words from address 1 to address 2 with data. Data can be multiple values (e.g. <code>F 0 20 1 2 3 4</code> fills address 0 to 0x20 with a repeating pattern of 1 2 3 4).



R[W] addr [count]	Reads “count” of bytes or words from the address specified by “addr”. If “count” is not specified, then 16 bytes/words are read.
W[W] addr data . . .	Writes bytes or words of data to address specified by “addr”. Data can be multiple values e.g. W 0 1 2 3 4 writes the byte values 1 2 3 4 starting at address 0).
I	Initializes the chip with user specified configuration.
M [bpp]	Returns information about the current mode. If “bpp” is specified then set the requested color depth.
P 0 1 2	Sets software power save mode 0-2. Power save mode 0 is normal operation.
H [lines]	Halts after specified lines of display. This feature halts the display during long read operations to prevent data from scrolling off the display. Set 0 to disable.
Q	Quits this utility.
?	Displays Help information.

## 13705PLAY Example

1. Type “13705PLAY” to start the program.
2. Type “?” for help.
3. Type “i” to initialize the registers.
4. Type “xa” to display the contents of the registers.
5. Type “x 5” to read register 5.
6. Type “x 3 10” to write 10 hex to register 3.
7. Type “f 0 400 aa” to fill the first 400 hex bytes of display memory with AA hex.
8. Type “f 0 14000 aa” to fill 80k bytes of display memory with AA hex.
9. Type “r 0 ff” to read the first 100 hex bytes of display memory.
10. Type “q” to exit the program.

## Scripting

13705PLAY can be driven by a script file. This is useful when:

- there is no standard display output to monitor command entry and results.
- various registers must be quickly changed faster than can be achieved by typing.
- The same series of keystrokes is being entered time and again.

A script file is an ASCII text file with one 13705PLAY command per line. All scripts must end with a “q” (quit) command in order to return control to the operating system. The semi-colon is used as a comment delimiter. Everything on a line after the semi-colon will be ignored.

On a PC platform, a typical script command line is: “13705PLAY < dumpregs.scr > results”.

This causes the script file “dumpregs.scr” to be interpreted and the results to be sent to the file “results.”

**Example 1:** *The script file “dumpregs.scr” can be created with any text editor and will look like the following:*

```
; This file initializes the S1D13705 and reads the registers  
i           ; Initialize the registers.  
xa         ; Dump all the registers  
la         ; And the LUT  
q           ; Exit
```

## Comments

- All numeric values are considered to be hexadecimal unless identified otherwise. For example, 10 = 10h = 16 decimal; 10t = 10 decimal; 010b = 2 decimal.
- Redirecting commands from a script file (PC platform) allows those commands to be executed as though they were typed.

---

## Program Messages

>>> **WARNING: DID NOT DETECT S1D13705** <<<

The HAL was unable to read the revision code register on the S1D13705. Ensure that the S1D13705 hardware is installed and that the hardware platform has been configured correctly. Also check that the display memory address has been configured correctly.

**ERROR: Unable to locate/load S1D13XXX.VXD**

13705PLAY was unable to load a required driver. The file S1D13XXX.VXD should be located in x:\WINDOWS\SYSTEM or in x:\WINNT\SYSTEM. If the file is not there, install it as described in the S1D13XXX 32-Bit Windows Device Driver Installation Guide, document number X00A-E-003-xx.

**ERROR: An IOCTL error occurred**

This message indicates an error at the IO control layer occurred. The usual cause for this is an incorrect hardware configuration.

**ERROR: The HAL returned an unknown error**

This message should never be displayed, it indicates that 13705SHOW is unable to determine the cause of an error returned from the HAL.

**THIS PAGE LEFT BLANK**



## **S1D13705 Embedded Memory LCD Controller**

# **13705BMP Demonstration Program**

**Document No. X27A-B-006-03**

Copyright © 2001 Epson Research and Development, Inc. All Rights Reserved.

Information in this document is subject to change without notice. You may download and use this document, but only for your own use in evaluating Seiko Epson/EPSON products. You may not modify the document. Epson Research and Development, Inc. disclaims any representation that the contents of this document are accurate or current. The Programs/Technologies described in this document may contain material protected under U.S. and/or International Patent laws.

EPSON is a registered trademark of Seiko Epson Corporation. All other Trademarks are the property of their respective owners

---

**THIS PAGE LEFT BLANK**

# 13705BMP

13705BMP is a demonstration program for the S1D13705 which can read and display .BMP format (Windows bitmap) files.

The 13705BMP display utility is designed to operate on an x86 based personal computer. There are both 16-bit and 32-bit versions of 13705BMP. The 16-bit version is for use under DOS when the S1D13705 evaluation board has been configured for D0000. The 32-bit version is intended for use under Win32. Before use 13705BMP must be configured for the display system. Consult documentation for the program 13705CFG.EXE which can be used to configure 13705BMP.

13705BMP is not supported on non-PC platforms.

## Installation

**For 16-Bit Program Version:** copy the file 13705BMP.EXE to a directory that is in the DOS path on your hard drive.

**For 32-Bit Program Version:** install the 32-bit Windows device driver S1D13X0X.VXD as described in the S1D13X0X 32-Bit Windows Device Driver Installation Guide, document number X00A-E-003-xx. Copy the file 13705BMP.EXE to a directory that is in the DOS path on your hard drive.

## Usage

At the prompt, type:

```
13705bmp bmp_file [/a[time]] [/l] [/p] [/noinit] [/?].
```

Where: `bmp_file` the name of the file to display

`/a[time]` automatic mode returns to the operating system after “time” seconds. If time is not specified the default is 5 seconds. This option is intended for use with batch files to automate displaying a series of images.

`/l` override default configuration settings and set landscape display mode.

`/p` override default configuration settings and set portrait display mode.

`/noinit` bypass the register initialization and use the current setup  
use this option to override changes that take place to the timing registers

`/?` displays the Help screen

## Comments

- 13705BMP currently views only Windows BMP format images.

## Program Messages

**ERROR: Did not find an S1D13705 device.**

The HAL was unable to locate an S1D13705 at the configured address. Check that the correct physical address was configured into 13705BMP.EXE

**ERROR: Unable to locate/load S1D13XXX.VXD**

The file S1D13XXX.VXD is required by the 32-bit version of the 13705BMP. Check that the .VXD file is in c:\WINDOWS\SYSTEM. If the file is not there, install it as described in the S1D13XXX 32-Bit Windows Device Driver Installation Guide, document number X00A-E-003-xx.

**ERROR: An IOCTL error occurred.**

The device driver S1D13XXX.VXD was unable to assign memory. Check that the PC hardware is configured correctly and that 13705BMP has been configured with the correct memory location.

**ERROR: The HAL returned an unknown error.**

This error message should never be seen. **Contact ERD.**

**ERROR: Could not initialize device.**

The HAL failed to initialize the S1D13705.

**Failed to open .BMP file '?.....?'**

13705BMP was unable to open the .BMP file ?.....? specified on the command line.

**?.....? is not a valid bitmap file.**

While performing validity checks it was determined that the file ?.....? is either not a valid .BMP file or is of an unsupported format.

**ERROR: Unable to set a suitable display mode.**

13705BMP was unable to set a display mode to view the image with.

**ERROR: Currently unable to process images greater than 8 bpp.**

13705BMP can decode images of 8BPP or less color depth. Try reducing the color depth of your image.

**ERROR: Image larger than display memory size.**

The amount of memory required by this image is more than the amount of memory available to the S1D13705. Try choosing a smaller image.

**ERROR: Unable to allocate enough memory to decode the image.**

In order to decode a .BMP image 13705BMP needs to allocate some additional system memory. This message is seen if the call to allocate additional memory fails.





## **S1D13705 Embedded Memory LCD Controller**

# **13705PWR Power Save Utility**

**Document No. X27A-B-007-03**

Copyright © 2001 Epson Research and Development, Inc. All Rights Reserved.

Information in this document is subject to change without notice. You may download and use this document, but only for your own use in evaluating Seiko Epson/EPSON products. You may not modify the document. Epson Research and Development, Inc. disclaims any representation that the contents of this document are accurate or current. The Programs/Technologies described in this document may contain material protected under U.S. and/or International Patent laws.

EPSON is a registered trademark of Seiko Epson Corporation. All other Trademarks are the property of their respective owners

---

**THIS PAGE LEFT BLANK**

# 13705PWR

The 13705PWR Power Save Utility is a tool to assist in the testing of the software and hardware power save modes.

Refer to the section titled “Power Save Modes” in the S1D13705 Programming Notes and Examples manual, document number X27A-G-002-xx, and the S1D13705 Functional Hardware Specification, document number X27A-A-001-xx for further information.

The 13705PWR utility must be configured and/or compiled to work with your hardware platform. Consult documentation for the program 13705CFG.EXE which can be used to configure 13705PWR.

This software is designed to work in both embedded and personal computer (PC) environments. For the embedded environment, it is assumed that the system has a means of downloading software from the PC to the target platform. Typically this is done by serial communications, where the PC uses a terminal program to send control commands and information to the target processor. Alternatively, the PC can program an EPROM, which is then placed in the target platform. Some target platforms can also communicate with the PC via a parallel port connection, or an Ethernet connection.

## S1D13705 Supported Evaluation Platforms

13705PWR has been designed to work with the following S1D13705 supported evaluation platforms:

- PC system with an x86 processor. Both 16-bit and 32-bit code is supported.
- M68EC000IDP (Integrated Development Platform) board, revision 3.0, with a Motorola M68EC000 processor.
- SH3-LCEVB board, revision B, with an Hitachi SH-3 HD6417780 processor.

If the platform you are using is different from the above, please see the S1D13705 “Programming Notes and Examples” manual, document number X27A-G-002-xx.

## Installation

### PC Platform

**For 16-Bit Program Version:** copy the file 13705PWR.EXE to a directory that is in the DOS path on your hard drive.

**For 32-Bit Program Version:** install the 32-bit Windows device driver S1D13XXX.VXD as described in the S1D13XXX 32-Bit Windows Device Driver Installation Guide, document number X00A-E-003-xx. Copy the file 13705PWR.EXE to a directory that is in the DOS path on your hard drive.

### Embedded Platform

Download the program 13705PWR to the system.

## Usage

**PC platform:** at the prompt, type **13705pwr [s0] [s1] [h0] [h1]**.

**Embedded platform:** execute 13705pwr and at the prompt, type the command line argument.

Where:

- s0 resets software power save mode
- s1 sets software power save mode
- h0 resets (disables) hardware power save mode (REG[03h] bit 2)
- h1 sets (enables) hardware power save mode (REG[03h] bit 2)
- /? displays this usage message

## Program Messages

### **ERROR: Did not find a 13705 device.**

The HAL was unable to read the revision code register on the S1D13705. Ensure that the S1D13705 hardware is installed and that the hardware platform has been configured correctly. Also check that the display memory address has been configured correctly.

### **ERROR: Unable to locate/load S1D13XXX.VXD**

13705PLAY was unable to load a required driver. The file S1D13XXX.VXD should be located in x:\WINDOWS\SYSTEM or in x:\WINNT\SYSTEM. If the file is not there, install it as described in the S1D13XXX 32-Bit Windows Device Driver Installation Guide, document number X00A-E-003-xx.

### **ERROR: An IOCTL error occurred**

This message indicates an error at the IO control layer occurred. The usual cause for this is an incorrect hardware configuration.

### **ERROR: The HAL returned an unknown error**

This message should never be displayed, it indicates that 13705SHOW is unable to determine the cause of an error returned from the HAL.

### **Software Power Save Mode set.**

This message is a confirmation that the register setting to enable software power save mode has been set.

### **Software Power Save Mode reset.**

This message is a confirmation that the register setting to disable software power save mode has been set.

### **Hardware Power Save Mode is now Enabled.**

This message confirms that hardware initiated power save mode has been enabled. The S1D13705 will enter a hardware power save mode upon application of the appropriate logic level to the hardware power save mode input pin.

### **Hardware Power Save Mode is now Disabled.**

This message confirms that the register setting to disable hardware initiated power save mode has been set. In this state the S1D13705 should ignore the state of the hardware power save mode input pin.

**THIS PAGE LEFT BLANK**

# EPSON®



## S1D13705 Embedded Memory LCD Controller

# Windows® CE 2.x Display Drivers

Document Number: X27A-E-001-03

Copyright © 2001 Epson Research and Development, Inc. All Rights Reserved.

Information in this document is subject to change without notice. You may download and use this document, but only for your own use in evaluating Seiko Epson/EPSON products. You may not modify the document. Epson Research and Development, Inc. disclaims any representation that the contents of this document are accurate or current. The Programs/Technologies described in this document may contain material protected under U.S. and/or International Patent laws.

EPSON is a registered trademark of Seiko Epson Corporation. Microsoft and Windows are registered trademarks of Microsoft Corporation. All other trademarks are the property of their respective owners.

---

**THIS PAGE LEFT BLANK**



---

## WINDOWS® CE 2.x DISPLAY DRIVERS

The Windows CE display driver is designed to support the S1D13705 Embedded Memory LCD Controller running under the Microsoft Windows CE 2.x operating system. The driver is capable of: 4 and 8 bit-per-pixel landscape modes (no rotation), and 4 and 8 bit-per-pixel SwivelView™ 270 degree mode.

This document and the source code for the Windows CE drivers are updated as appropriate. Before beginning any development, please check the Epson Electronics America Website at [www.eea.epson.com](http://www.eea.epson.com) or the Epson Research and Development Website at [www.erd.epson.com](http://www.erd.epson.com) for the latest revisions.

We appreciate your comments on our documentation. Please contact us via email at [techpubs@erd.epson.com](mailto:techpubs@erd.epson.com).

## Example Driver Builds

The following sections describe how to build the Windows CE display driver for:

1. Windows CE 2.0 using a command-line interface.
2. Windows CE Platform Builder 2.1x using a command-line interface.

In all examples “x:” refers to the drive letter where Platform Builder is installed.

### Build for CEPC (X86) on Windows CE 2.0 using a Command-Line Interface

To build a Windows CE v2.0 display driver for the CEPC (X86) platform using a S5U13705B00C evaluation board, follow the instructions below:

1. Install Microsoft Windows NT v4.0 or 2000.
2. Install Microsoft Visual C/C++ version 5.0 or 6.0.
3. Install the Microsoft Windows CE Embedded Toolkit (ETK) by running SETUP.EXE from the ETK compact disc #1.
4. Create a new project by following the procedure documented in “Creating a New Project Directory” from the Windows CE ETK v2.0. Alternately, use the current “DEMO7” project included with the ETK v2.0. Follow the steps below to create a “X86 DEMO7” shortcut on the Windows NT v4.0 desktop which uses the current “DEMO7” project:
  - a. Right click on the “Start” menu on the taskbar.
  - b. Click on the item “Open All Users” and the “Start Menu” window will come up.
  - c. Click on the icon “Programs”.
  - d. Click on the icon “Windows CE Embedded Development Kit”.
  - e. Drag the icon “X86 DEMO1” onto the desktop using the right mouse button.
  - f. Click on “Copy Here”.
  - g. Rename the icon “X86 DEMO1” on the desktop to “X86 DEMO7” by right clicking on the icon and choosing “rename”.
  - h. Right click on the icon “X86 DEMO7” and click on “Properties” to bring up the “X86 DEMO7 Properties” window.
  - i. Click on “Shortcut” and replace the string “DEMO1” under the entry “Target” with “DEMO7”.
  - j. Click on “OK” to finish.
5. Create a sub-directory named S1D13705 under x:\wince\platform\cepc\drivers\display.
6. Copy the source code to the S1D13705 subdirectory.

7. Edit the file `x:\wince\platform\cepc\drivers\display\dirs` and add `S1D13705` into the list of directories.
8. Edit the file `PLATFORM.BIB` (located in `x:\wince\platform\cepc\files`) to set the default display driver to the file `EPSON.DLL` (`EPSON.DLL` will be created during the build in step 13).

Replace or comment out the following lines in `PLATFORM.BIB`:

```
IF CEPC_DDI_VGA2BPP
    ddi.dll    $_FLATRELEASEDIR)\ddi_vga2.dll    NK SH
ENDIF
IF CEPC_DDI_VGA8BPP
    ddi.dll    $_FLATRELEASEDIR)\ddi_vga8.dll    NK SH
ENDIF
IF CEPC_DDI_VGA2BPP !
IF CEPC_DDI_VGA8BPP !
    ddi.dll    $_FLATRELEASEDIR)\ddi_s364.dll    NK SH
ENDIF
ENDIF
```

with this line:

```
ddi.dll    $_FLATRELEASEDIR)\EPSON.dll    NK SH
```

9. The file `MODE0.H` (located in `x:\wince\platform\cepc\drivers\display\S1D13705`) contains the register values required to set the screen resolution, color depth (bpp), display type, active display (LCD/CRT/TV), display rotation, etc.

Before building the display driver, refer to the descriptions in the file `MODE0.H` for the default settings of the driver. If the default does not match the configuration you are building for then `MODE0.H` will have to be regenerated with the correct information.

Use the program `13705CFG` to generate the header file. For information on how to use `13705CFG`, refer to the *13705CFG Configuration Program User Manual*, document number `X27A-B-001-xx`, available at [www.erd.epson.com](http://www.erd.epson.com)

After selecting the desired configuration, export the file as a “C Header File for `S1D13705 WinCE Drivers`”. Save the new configuration as `MODE0.H` in `x:\wince\platform\cepc\drivers\display\S1D13705`, replacing the original configuration file.

10. Edit the file `PLATFORM.REG` to match the screen resolution, color depth (bpp), active display (LCD/CRT/TV) and rotation information in `MODE.H`. `PLATFORM.REG` is located in `x:\wince\platform\cepc\files`.

For example, the display driver section of PLATFORM.REG should be as follows when using a 320x240 LCD panel with a color depth of 8 bpp in SwivelView 0° (landscape) mode:

```
; Default for EPSON Display Driver
; 320x240 at 8 bits/pixel, LCD display, no rotation
; Useful Hex Values
; 1024=0x400, 768=0x300 640=0x280 480=0x1E0 320=140 240=0xF0
[HKEY_LOCAL_MACHINE\Drivers\Display\S1D13705]
"Width"=dword:140
"Height"=dword:F0
"Bpp"=dword:8
"ActiveDisp"=dword:1
"Rotation"=dword:0
```

11. Delete all the files in the x:\wince\release directory, and delete x:\wince\platform\cepc\\*.bif
12. Generate the proper building environment by double-clicking on the sample project icon (i.e. X86 DEMO7).
13. Type BLDDEMO <ENTER> at the command prompt of the X86 DEMO7 window to generate a Windows CE image file (NK.BIN).

### **Build for CEPC (X86) on Windows CE Platform Builder 2.1x using a Command-Line Interface**

Throughout this section 2.1x refers to either 2.11 or 2.12 as appropriate.

1. Install Microsoft Windows NT v4.0 or 2000.
2. Install Microsoft Visual C/C++ version 5.0 or 6.0.
3. Install Platform Builder 2.1x by running SETUP.EXE from compact disk #1.
4. Follow the steps below to create a "Build Epson for x86" shortcut which uses the current "Minshell" project icon/shortcut on the Windows desktop.
  - a. Right click on the "Start" menu on the taskbar.
  - b. Click on the item "Explore", and "Exploring -- Start Menu" window will come up.
  - c. Under "x:\winnt\profiles\all users\start menu\programs\microsoft windows ce platform builder\x86 tools", find the icon "Build Minshell for x86".
  - d. Drag the icon "Build Minshell for x86" onto the desktop using the right mouse button.

- e. Choose “Copy Here”.
  - f. Rename the icon “Build Minshell for x86” to “Build Epson for x86” by right clicking on the icon and choosing “rename”.
  - g. Right click on the icon “Build Epson for x86” and click on “Properties” to bring up the “Build Epson for x86 Properties” window.
  - h. Click on “Shortcut” and replace the string “Minshell” under the entry “Target” with “Epson”.
  - i. Click on “OK” to finish.
5. Create an EPSON project.
- a. Make an Epson directory under x:\wince\public.
  - b. Copy MAXALL and its sub-directories (x:\wince\public\maxall) to the Epson directory.

```
xcopy /s /e x:\wince\public\maxall\*. * \wince\public\epson
```

- c. Rename x:\wince\public\epson\maxall.bat to epson.bat.
  - d. Edit EPSON.BAT to add the following lines to the end of the file:  

```
@echo on  
set CEPC_DDI_S1D13705=1  
@echo off
```
6. Make an S1D13705 directory under x:\wince\platform\cepc\drivers\display, and copy the S1D13705 driver source code into x:\wince\platform\cepc\drivers\display\S1D13705.
7. Edit the file x:\wince\platform\cepc\drivers\display\dirs and add S1D13705 into the list of directories.
8. Edit the file x:\wince\platform\cepc\files\platform.bib and make the following two changes:

- a. Insert the following text after the line “IF ODO\_NODISPLAY !”:

```
IF CEPC_DDI_S1D13705  
    ddi.dll    $_FLATRELEASEDIR)\epson.dll    NK SH  
ENDIF
```

- b. Find the section shown below, and insert the lines as marked:

```
IF CEPC_DDI_S1D13705 !           Insert this line  
IF CEPC_DDI_S3VIRGE !  
IF CEPC_DDI_CT655X !  
IF CEPC_DDI_VGA8BPP !
```

```

        ddi.dll    $(_FLATRELEASEDIR)\ddi_s364.dll    NK SH
    ENDIF
    ENDIF
    ENDIF
    ENDIF

```

*Insert this line*

9. The file MODE0.H (located in x:\wince\platform\cepc\drivers\display\S1D13705) contains the register values required to set the screen resolution, color depth (bpp), display type, active display (LCD/CRT/TV), display rotation, etc.

Before building the display driver, refer to the descriptions in the file MODE0.H for the default settings of the driver. If the default does not match the configuration you are building for then MODE0.H will have to be regenerated with the correct information.

Use the program 13705CFG to generate the header file. For information on how to use 13705CFG, refer to the *13705CFG Configuration Program User Manual*, document number X27A-B-001-xx, available at [www.erd.epson.com](http://www.erd.epson.com)

After selecting the desired configuration, export the file as a “C Header File for S1D13705 WinCE Drivers”. Save the new configuration as MODE0.H in x:\wince\platform\cepc\drivers\display\S1D13705, replacing the original configuration file.

10. Edit the file PLATFORM.REG to match the screen resolution, color depth (bpp), active display (LCD/CRT/TV) and rotation information in MODE.H. PLATFORM.REG is located in x:\wince\platform\cepc\files.

For example, the display driver section of PLATFORM.REG should be as follows when using a 320x240 LCD panel with a color depth of 8 bpp in SwivelView 0° (landscape) mode:

```

; Default for EPSON Display Driver
; 320x240 at 8 bits/pixel, LCD display, no rotation
; Useful Hex Values
; 1024=0x400, 768=0x300 640=0x280 480=0x1E0 320=140 240=0xF0
[HKEY_LOCAL_MACHINE\Drivers\Display\S1D13705]
"Width"=dword:140
"Height"=dword:F0
"Bpp"=dword:8
"ActiveDisp"=dword:1
"Rotation"=dword:0

```

11. Delete all the files in \wince\release directory and delete x:\wince\platform\cepc\\*.bif

12. Generate the proper building environment by double-clicking on the Epson project icon --"Build Epson for x86".
13. Type BLDDemo <ENTER> at the command prompt of the "Build Epson for x86" window to generate a Windows CE image file (NK.BIN).

## Installation for CEPC Environment

Once the NK.BIN file is built, the CEPC environment can be started by booting either from a floppy or hard drive configured with a Windows 9x operating system. The two methods are described below.

1. To start CEPC after booting from a floppy drive:

- a. Create a bootable floppy disk.
- b. Edit CONFIG.SYS on the floppy disk to contain only the following line:

```
device=a:\himem.sys
```

- c. Edit AUTOEXEC.BAT on the floppy disk to contain the following lines:

```
mode com1:9600,n,8,1  
loadcepc /B:9600 /C:1 c:\nk.bin
```

- d. Copy LOADCEPC.EXE and HIMEM.SYS to the bootable floppy disk. Search for the loadCEPC utility in your Windows CE directories.
- e. Copy NK.BIN to c:\.
- f. Boot the system from the bootable floppy disk.

2. To start CEPC after booting from a hard drive:

- a. Copy LOADCEPC.EXE to C:\. Search for the loadCEPC utility in your Windows CE directories.
- b. Edit CONFIG.SYS on the hard drive to contain only the following line:

```
device=c:\himem.sys
```

- c. Edit AUTOEXEC.BAT on the hard drive to contain the following lines:

```
mode com1:9600,n,8,1  
loadcepc /B:9600 /C:1 c:\nk.bin
```

- d. Copy NK.BIN and HIMEM.SYS to c:\.
- e. Boot the system.



## Configuration

There are several issues to consider when configuring the display driver. The issues cover debugging support, register initialization values and memory allocation. Each of these issues is discussed in the following sections.

### Compile Switches

There are several switches, specific to the S1D13705 display driver, which affect the display driver.

The switches are added or removed from the compile options in the file SOURCES.

#### **WINCEVER**

This option is automatically set to the numerical version of WinCE for version 2.12 or later. If the environment variable, `_WINCEOSVER` is not defined, then `WINCEVER` will default 2.11. The display driver may test against this option to support different WinCE version-specific features.

#### **DEBUG\_MONITOR**

This option enables the use of the debug monitor. The debug monitor can be invoked when the display driver is first loaded and can be used to view registers, and perform a few debugging tasks. The debug monitor is still under development and is untested.

This option should remain disabled unless you are performing specific debugging tasks that require the debug monitor.

#### **TEST\_BITMAP**

This option allows the debug monitor to display a test bitmap. This bitmap is big and will make the display driver considerably larger. The flag `DEBUG_MONITOR` must also be enabled for this option to work.

This option should be disabled unless the image is required for debugging.

## Mode File

A second variable which will affect the finished display driver is the register configurations contained in the mode file.

The MODE tables (contained in files MODE0.H, MODE1.H, MODE2.H . . .) contain register information to control the desired display mode. The MODE tables must be generated by the configuration program 13705CFG.EXE. The display driver comes with example MODE tables.

By default, only MODE0.H is used by the display driver. New mode tables can be created using the 13705CFG program. Edit the #include section of MODE.H to add the new mode table.

If you only support a single display mode, you do not need to add any information to the WinCE registry. If, however, you support more than one display mode, you should create registry values (see below) that will establish the initial display mode. If your display driver contains multiple mode tables, and if you do not add any registry values, the display driver will default to the **first** mode table in your list.

To select which display mode the display driver should use upon boot, add the following lines to your PLATFORM.REG file:

```
[HKEY_LOCAL_MACHINE\Drivers\Display\S1D13705]
```

```
“Width”=dword:140  
“Height”=dword:F0  
“Bpp”=dword:8  
“Rotation”=dword:0  
“RefreshRate”=dword:3C  
“Flags”=dword:1
```

Note that all dword values are in hexadecimal, therefore 140h = 320, F0h = 240, and 3Ch = 60. The value for “Flags” should be 1 (LCD). When the display driver starts, it will read these values in the registry and attempt to match a mode table against them. All values must be present and valid for a match to occur, otherwise the display driver will default to the FIRST mode table in your list.

A WinCE desktop application (or control panel applet) can change these registry values, and the display driver will select a different mode upon warmboot. This allows the display driver to support different display configurations and/or orientations. An example application that controls these registry values will be made available upon the next release of the display driver; preliminary alpha code is available by special request.

## Comments

- The display driver is CPU independent, allowing use of the driver for several Windows CE Platform Builder supported platforms.
- When using 13705CFG.EXE to produce multiple MODE tables, make sure you change the Mode Number in the WinCE tab for each mode table you generate. The display driver supports multiple mode tables, but only if each mode table has a unique mode number.
- At this time, the drivers have been tested on the x86 CPUs and have been run with version 2.0 of the ETK, Platform Builder v2.1x.

**THIS PAGE LEFT BLANK**

# EPSON®



## S1D13705 Embedded Memory LCD Controller

# Wind River WindML v2.0 Display Drivers

Document Number: X27A-E-002-03

Copyright © 2001 Epson Research and Development, Inc. All Rights Reserved.

Information in this document is subject to change without notice. You may download and use this document, but only for your own use in evaluating Seiko Epson/EPSON products. You may not modify the document. Epson Research and Development, Inc. disclaims any representation that the contents of this document are accurate or current. The Programs/Technologies described in this document may contain material protected under U.S. and/or International Patent laws.

EPSON is a registered trademark of Seiko Epson Corporation. All other trademarks are the property of their respective owners.

---

**THIS PAGE LEFT BLANK**

# Wind River WindML v2.0 DISPLAY DRIVERS

The Wind River WindML v2.0 display drivers for the S1D13705 Embedded Memory LCD Controller are intended as “reference” source code for OEMs developing for Wind River’s WindML v2.0. The driver package provides support for 8 bit-per-pixel color depth. The source code is written for portability and contains functionality for most features of the S1D13705. Source code modification is required to provide a smaller, more efficient driver for mass production (e.g. SwivelView™ support may be removed for products not requiring display rotation).

The WindML display drivers are designed around a common configuration include file called **mode0.h** which is generated by the configuration utility 13705CFG. This design allows for easy customization of clocks, decode addresses, rotation, etc. by OEMs. For further information on 13705CFG, see the *13705CFG Configuration Program User Manual*, document number X27A-B-001-xx.

## Note

The WindML display drivers are provided as “reference” source code only. They are intended to provide a basis for OEMs to develop their own drivers for WindML v2.0.

These drivers are not backwards compatible with UGL v1.2. For information on the UGL v1.2 display drivers, see *Wind River UGL v1.2 Display Drivers*, document number X27A-E-003-xx.

This document and the source code for the WindML display drivers is updated as appropriate. Please check the Epson Electronics America website at <http://www.eea.epson.com> or the Epson Research and Development website at <http://www.erd.epson.com> for the latest revisions before beginning any development.

We appreciate your comments on our documentation. Please contact us via email at [documentation@erd.epson.com](mailto:documentation@erd.epson.com).

## Building a WindML v2.0 Display Driver

The following instructions produce a bootable disk that automatically starts the UGL demo program. These instructions assume that Wind River's Tornado platform is already installed.

### Note

For the example steps where the drive letter is given as "x:". Substitute "x" with the drive letter that your development environment is on.

1. Create a working directory and unzip the WindML display driver into it.

From a command prompt or GUI interface create a new directory (e.g. x:\13705).

Unzip the file **13705windml.zip** to the newly created working directory. The files will be unzipped to the directory "x:\13705\8bpp".

2. Configure for the target execution model.

This example build creates a VxWorks image that fits onto and boots from a single floppy diskette. In order for the VxWorks image to fit on the disk certain modifications are required.

Replace the file "x:\Tornado\target\config\pcPentium\config.h" with the file "x:\13705\8bpp\File\config.h". The new **config.h** file removes networking components and configures the build image for booting from a floppy disk.

### Note

Rather than simply replacing the original **config.h** file, rename it so the file can be kept for reference purposes.

3. Build a boot ROM image.

From the Tornado tool bar, select Build -> Build Boot ROM. Select "pcPentium" as the BSP and "bootrom\_uncmp" as the image.

4. Create a bootable disk (in drive A:).

From a command prompt change to the directory "x:\Tornado\host\x86-win32\bin" and run the batch file **torvars.bat**. Next, change to the directory "x:\Tornado\target\config\pcPentium" and type:

```
mkboot a: bootrom_uncmp
```

5. If necessary, generate a new **mode0.h** configuration file.

The file **mode0.h** contains the register values required to set the screen resolution, color depth (bpp), display type (passive or active matrix), rotation, etc. The **mode0.h** file included with the drivers, may not contain applicable values and must be regenerated. The configuration program 13705CFG can be used to build a new **mode0.h** file. If building for 8 bpp, place the new **mode0.h** file in the directory "x:\13705\8bpp\File".



## Note

**Mode0.h** should be created using the configuration utility 13705CFG. For more information on 13705CFG, see the *13705CFG Configuration Program User Manual*, document number X27A-B-001-xx available at [www.erd.epson.com](http://www.erd.epson.com).

6. Build the WindML v2.0 library.

From a command prompt change to the directory “x:\Tornado\host\x86-win32\bin” and run the batch file **torvars.bat**. Next, change to the directory “x:\Tornado\target\src\ugl” and type the command:

**make CPU=PENTIUM ugl**

7. Open the S1D13705 workspace.

From the Tornado tool bar, select File->Open Workspace...->Existing->Browse... and select the file “x:\13705\8bpp\13705.wsp”.

8. Add support for single line comments.

The WindML v2.0 display driver source code uses single line comment notation, “//”, rather than the ANSI conventional comments, “/\*...\*/”.

To add support for single line comments follow these steps:

- a. In the Tornado “Workspace Views” window, click on the “Builds” tab.
  - b. Expand the “8bpp Builds” view by clicking on the “+” next to it. The expanded view will contain the item “default”. Right-click on “default” and select “Properties...”. A “Properties:” window will appear.
  - c. Select the “C/C++ compiler” tab to display the command switches used in the build. Remove the “-ansi” switch from the line that contains “-g -mpentium -ansi -nostdinc -DRW\_MULTI\_THREAD”.  
(Refer to GNU ToolKit user's guide for details)
9. Compile the VxWorks image.  
Select the “Builds” tab in the Tornado “Workspace Views” window.  
Right-click on “8bpp files” and select “Dependencies...”. Click on “OK” to regenerate project file dependencies for “All Project files”.  
Right-click on “8bpp files” and select “ReBuild All(vxWorks)” to build VxWorks.
  10. Copy the VxWorks file to the diskette.  
From a command prompt or through the Windows interface, copy the file “x:\13705\8bpp\default\vxWorks” to the bootable disk created in step 4.
  11. Start the VxWorks demo.

Boot the target PC with the VxWorks bootable diskette to run the UGLDEMO automatically.

**THIS PAGE LEFT BLANK**

# EPSON®



## S1D13705 Embedded Memory LCD Controller

# Wind River UGL v1.2 Display Drivers

**Document Number: X27A-E-003-02**

Copyright © 2001 Epson Research and Development, Inc. All Rights Reserved.

Information in this document is subject to change without notice. You may download and use this document, but only for your own use in evaluating Seiko Epson/EPSON products. You may not modify the document. Epson Research and Development, Inc. disclaims any representation that the contents of this document are accurate or current. The Programs/Technologies described in this document may contain material protected under U.S. and/or International Patent laws.

EPSON is a registered trademark of Seiko Epson Corporation. Microsoft and Windows are registered trademarks of Microsoft Corporation. All other trademarks are the property of their respective owners.

---

**THIS PAGE LEFT BLANK**

## Wind River UGL v1.2 Display Drivers

The Wind River UGL v1.2 display drivers for the S1D13705 Embedded Memory LCD Controller are intended as “reference” source code for OEMs developing for Wind River’s UGL v1.2. The drivers provide support for 8 bit-per-pixel color depth. The source code is written for portability and contains functionality for most features of the S1D13705. Source code modification is required to provide a smaller, more efficient driver for mass production.

The UGL display drivers are designed around a common configuration include file called **mode0.h** which is generated by the configuration utility 13705CFG. This design allows for easy customization of display type, clocks, addresses, rotation, etc. by OEMs. For further information on 13705CFG, see the *13705CFG Configuration Program User Manual*, document number X27A-B-001-xx.

This document and the source code for the UGL display drivers are updated as appropriate. Please check the Epson Electronics America website at <http://www.eea.epson.com> or the Epson Research and Development website at <http://www.erd.epson.com> for the latest revisions before beginning any development.

We appreciate your comments on our documentation. Please contact us via e-mail at [documentation@erd.epson.com](mailto:documentation@erd.epson.com).

## Building a UGL v1.2 Display Driver

The following instructions produce a bootable disk that automatically starts the UGL demo software. These instructions assume that the Wind River Tornado platform is correctly installed.

### Note

For the example steps where the drive letter is given as “x:”. Substitute “x” with the drive letter that your development environment is on.

1. Create a working directory and unzip the UGL display driver into it.

Using a command prompt or GUI interface create a new directory (e.g. x:\13705).

Unzip the file **13705ugl.zip** to the newly created working directory. The files will be unzipped to the directory “x:\13705\8bpp”.

2. Configure for the target execution model.

This example build creates a VxWorks image that fits onto and boots from a single floppy diskette. In order for the VxWorks image to fit on the disk certain modifications are required.

Replace the file “x:\Tornado\target\config\pcPentium\config.h” with the file “x:\13705\8bpp\File\config.h”. The new **config.h** file removes networking components and configures the build image for booting from a floppy disk.

### Note

Rather than simply replacing the original **config.h** file, rename it so the file can be kept for reference purposes.

3. Build a boot ROM image.

From the Tornado tool bar, select Build -> Build Boot ROM. Select “pcPentium” as the BSP and “bootrom\_uncmp” as the image.

4. Create a bootable disk (in drive A:).

From a command prompt in the directory “x:\Tornado\target\config\pcPentium” type  
**mkboot a: bootrom\_uncmp**

5. If necessary, generate a new **mode0.h** configuration file.

The file **mode0.h** contains the register values required to set the screen resolution, color depth (bpp), display type, rotation, etc. The **mode0.h**, included with the drivers, sets the display for 256x64 190 Hz output to an LCD display.

If this setting is inappropriate then **mode0.h** must be regenerated. The configuration program 13705CFG can be used to build a new **mode0.h** file. Place the new **mode0.h** file in “x:\13705\8bpp\File”.

## Note

**Mode0.h** should be created using the configuration utility 13705CFG. For more information on 13705CFG, see the *13705CFG Configuration Program User Manual*, document number X27A-B-001-xx available at [www.erd.epson.com](http://www.erd.epson.com).

6. Open the S1D13705 workspace.

From the Tornado tool bar, select File->Open Workspace...->Existing->Browse... and select the file "x:\13705\8bpp\13705.wsp".

7. Add support for single line comments.

The UGL v1.2 display driver source code uses single line comment notation, "//", rather than the ANSI conventional comments, "/\* . . . \*/".

To add support for single line comments follow these steps:

- a. In the Tornado "Workspace" window, click on the "Builds" tab.
  - b. Expand the "8bpp Builds" view by clicking on the "+" next to it. The expanded view will contain the item "default". Right-click on "default" and select "Properties...". A properties window will appear.
  - c. Select the "C/C++ compiler" tab to display the command switches used in the build. Remove the "-ansi" switch from the line that contains "-g -mpentium -ansi -nostdinc -DRW\_MULTI\_THREAD". (Refer to GNU ToolKit user's guide for details)
8. Compile the VxWorks image.

Select the "Files" tab in the Tornado "Workspace" window.

Right-click on "8bpp files" and select "Dependencies...". Click on "OK" to regenerate project file dependencies for "All Project files".

Right-click on "8bpp files" and select "ReBuild All(vxWorks)" to build VxWorks.

9. Copy the VxWorks file to the diskette.

From a command prompt or through the Windows interface, copy the file "x:\13705\8bpp\default\vxWorks" to the bootable disk created in step 4.

10. Start the VxWorks demo.

Boot the target PC with the VxWorks bootable diskette to run the UGLDEMO automatically.

**THIS PAGE LEFT BLANK**



# EPSON®



## S1D13705 Embedded Memory LCD Controller

# Linux Console Driver

**Document Number: X27A-E-004-02**

Copyright © 2001 Epson Research and Development, Inc. All Rights Reserved.

Information in this document is subject to change without notice. You may download and use this document, but only for your own use in evaluating Seiko Epson/EPSON products. You may not modify the document. Epson Research and Development, Inc. disclaims any representation that the contents of this document are accurate or current. The Programs/Technologies described in this document may contain material protected under U.S. and/or International Patent laws.

EPSON is a registered trademark of Seiko Epson Corporation.

---

**THIS PAGE LEFT BLANK**

---

# Linux Console Driver

The Linux console driver for the S1D13705 Embedded Memory LCD Controller is intended as “reference” source code for OEMs developing for Linux, and supports 4 and 8 bit-per-pixel color depths.

A Graphical User Interface (GUI) such as Gnome can obtain the frame buffer address from this driver allowing the Linux GUI the ability to update the display.

The console driver is designed around a common configuration include file called **s1d13705.h**, which is generated by the configuration utility 13705CFG. This design allows for easy customization of display type, clocks, decode addresses, rotation, etc. by OEMs. For further information on 13705CFG, see the *13705CFG Configuration Program User Manual*, document number X27A-B-001-xx.

## Note

The Linux console driver is provided as “reference” source code only. The driver is intended to provide a basis for OEMs to develop their own drivers for Linux.

This document and the source code for the Linux console drivers are updated as appropriate. Please check the Epson Research and Development website at <http://www.erd.epson.com> for the latest revisions or before beginning any development.

We appreciate your comments on our documentation. Please contact us via e-mail at [documentation@erd.epson.com](mailto:documentation@erd.epson.com).

## Building the Console Driver for Linux Kernel 2.2.x

Follow the steps below to construct a copy of the Linux operating system using the S1D13705 as the console display device. These instructions assume that the GNU development environment is installed and the user is familiar with GNU and the Linux operating system.

1. Acquire the Linux kernel source code.

You can obtain the Linux kernel source code from your Linux supplier or download the source from: <ftp://ftp.kernel.org>.

The S1D13705 reference driver requires Linux kernel 2.2.x or greater. The example S1D13705 reference driver available on [www.erd.epson.com](http://www.erd.epson.com) was built using Red Hat Linux 6.1, kernel version 2.2.17.

For information on building the kernel refer to the readme file at:

<ftp://ftp.linuxberg.com/pub/linux/kernel/README>

### Note

Before continuing with modifications for the S1D13705, you should ensure that you can build and start the Linux operating system.

2. Unzip the console driver files.

Using a zip file utility, unzip the S1D13705 archive to a temporary directory. (e.g. /tmp)

When completed the files:

s1d13xxfb.c  
s1d13705.h  
Config.in  
fbmem.c  
fbcon-cfb4.c, and  
Makefile

should be located in the temporary directory.

3. Copy the console driver files to the build directory.

Copy the files

/tmp/s1d13xxfb.c and  
/tmp/s1d13705.h

to the directory /usr/src/linux/drivers/video.

Copy the remaining source files

/tmp/Config.in  
/tmp/fbmem.c  
/tmp/fbcon-cfb4.c, and  
/tmp/Makefile

into the directory /usr/src/linux/drivers/video replacing the files of the same name.

If your kernel version is not 2.2.17 or you want to retain greater control of the build process then use a text editor and cut and paste the sections dealing with the Epson driver in the corresponding files of the same names.

#### 4. Modify s1d13705.h

The file s1d13705.h contains the register values required to set the screen resolution, color depth (bpp), display type, display rotation, etc.

Before building the console driver, refer to the descriptions in the file s1d13705.h for the default settings of the console driver. If the default does not match the configuration you are building for then s1d13705.h will have to be regenerated with the correct information.

Use the program 13705CFG to generate the required header file. For information on how to use 13705CFG, refer to the 13705CFG Configuration Program User Manual, document number X27A-B-001-xx, available at [www.erd.epson.com](http://www.erd.epson.com)

After selecting the desired configuration, choose “File->Export” and select the “C Header File for S1D13705 Generic Drivers” option. Save the new configuration as s1d13705.h in the /usr/src/linux/drivers/video, replacing the original configuration file.

#### 5. Configure the video options.

From the command prompt in the directory /usr/src/linux run the command:  
make menuconfig

This command will start a text based interface which allows the selection of build time parameters. From the text interface under “Console drivers” options, select:

- “Support for frame buffer devices”
- “Epson LCD/CRT controllers support”
- “S1D13705 support”
- “Advanced low level driver options”
- “xBpp packed pixels support” \*

\* where x is the color depth being compile for.

Once you have configured the kernel options, save and exit the configuration utility.

#### 6. Compile and install the kernel

Build the kernel with the following sequence of commands:

- make dep
- make clean
- make bzImage
- /sbin/lilo (if running lilo)

## 7. Boot to the Linux operating system

If you are using lilo (Linux Loader), modify the lilo configuration file as discussed in the kernel build README file. If there were no errors during the build, from the command prompt run:

```
lilo
```

and reboot your system.

### **Note**

In order to use the S1D13705 console driver with X server, you need to configure the X server to use the FBDEV device. A good place to look for the necessary files and instructions on this process is on the Internet at [www.xfree86.org](http://www.xfree86.org)

## Building the Console Driver for Linux Kernel 2.4.x

Follow the steps below to construct a copy of the Linux operating system using the S1D13705 as the console display device. These instructions assume that the GNU development environment is installed and the user is familiar with GNU and the Linux operating system.

1. Acquire the Linux kernel source code.

You can obtain the Linux kernel source code from your Linux supplier or download the source from: <ftp://ftp.kernel.org>.

The S1D13705 reference driver requires Linux kernel 2.4.x or greater. The example S1D13705 reference driver available on [www.erd.epson.com](http://www.erd.epson.com) was built using Red Hat Linux 6.1, kernel version 2.4.5.

For information on building the kernel refer to the readme file at:  
<ftp://ftp.linuxberg.com/pub/linux/kernel/README>

### Note

Before continuing with modifications for the S1D13705, you should ensure that you can build and start the Linux operating system.

2. Unzip the console driver files.

Using a zip file utility, unzip the S1D13705 archive to a temporary directory. (e.g. /tmp)

When completed the files:

Config.in  
fbmem.c  
fbcon-cfb4.c  
Makefile

should be located in the temporary directory (/tmp), and the files:

Makefile  
s1d13xxxfb.c  
s1d13705.h

should be located in a sub-directory called epson within the temporary directory (/tmp/epson).

3. Copy the console driver files to the build directory. Make the directory /usr/src/linux/drivers/video/epson.

Copy the files

/tmp/epson/s1d13xxxfb.c  
/tmp/epson/s1d13705.h  
/tmp/epson/Makefile

to the directory /usr/src/linux/drivers/video/epson.

Copy the remaining source files

```
/tmp/Config.in  
/tmp/fbmem.c  
/tmp/fbcon-cfb4.c  
/tmp/Makefile
```

into the directory `/usr/src/linux/drivers/video` replacing the files of the same name.

If your kernel version is not 2.4.5 or you want to retain greater control of the build process then use a text editor and cut and paste the sections dealing with the Epson driver in the corresponding files of the same names.

#### 4. Modify `s1d13705.h`

The file `s1d13705.h` contains the register values required to set the screen resolution, color depth (bpp), display type, display rotation, etc.

Before building the console driver, refer to the descriptions in the file `s1d13705.h` for the default settings of the console driver. If the default does not match the configuration you are building for then `s1d13705.h` will have to be regenerated with the correct information.

Use the program `13705CFG` to generate the required header file. For information on how to use `13705CFG`, refer to the `13705CFG Configuration Program User Manual`, document number `X27A-B-001-xx`, available at [www.erd.epson.com](http://www.erd.epson.com)

After selecting the desired configuration, choose “File->Export” and select the “C Header File for S1D13705 Generic Drivers” option. Save the new configuration as `s1d13705.h` in the `/usr/src/linux/drivers/video`, replacing the original configuration file.

#### 5. Configure the video options.

From the command prompt in the directory `/usr/src/linux` run the command:

```
make menuconfig
```

This command will start a text based interface which allows the selection of build time parameters. From the options presented select:

```
“Code maturity level” options  
  “Prompt for development and/or incomplete drivers”  
“Console drivers” options  
  “Frame-buffer support”  
    “Support for frame buffer devices (EXPERIMENTAL)”  
      “EPSON LCD/CRT/TV controller support”  
        “EPSON S1D13705 Support”  
          “Advanced low-level driver options”  
            “xbpp packed pixels support” *
```

\* where x is the color depth being compile for.

Once you have configured the kernel options, save and exit the configuration utility.



6. Compile and install the kernel

Build the kernel with the following sequence of commands:

```
make dep
make clean
make bzImage
/sbin/lilo (if running lilo)
```

7. Boot to the Linux operating system

If you are using lilo (Linux Loader), modify the lilo configuration file as discussed in the kernel build README file. If there were no errors during the build, from the command prompt run:

```
lilo
```

and reboot your system.

**Note**

In order to use the S1D13705 console driver with X server, you need to configure the X server to use the FBDEV device. A good place to look for the necessary files and instructions on this process is on the Internet at [www.xfree86.org](http://www.xfree86.org)

**THIS PAGE LEFT BLANK**

# EPSON®



## S1D13705 Embedded Memory LCD Controller

# QNX Photon v2.0 Display Driver

**Document Number: X27A-E-005-01**

Copyright © 2001 Epson Research and Development, Inc. All Rights Reserved.

Information in this document is subject to change without notice. You may download and use this document, but only for your own use in evaluating Seiko Epson/EPSON products. You may not modify the document. Epson Research and Development, Inc. disclaims any representation that the contents of this document are accurate or current. The Programs/Technologies described in this document may contain material protected under U.S. and/or International Patent laws.

EPSON is a registered trademark of Seiko Epson Corporation. All other trademarks are the property of their respective owners.

---

**THIS PAGE LEFT BLANK**

## QNX Photon v2.0 Display Driver

The Photon v2.0 display drivers for the S1D13705 Color LCD Controller are intended as “reference” source code for OEMs developing for QNX platforms. The driver package provides support for 8 bit-per-pixel color depths. The source code is written for portability and contains functionality for most features of the S1D13705. Source code modification is required to provide a smaller driver for mass production.

The current revision of the driver is designed for use with either QNX RTP or QNX4 from the latest product CD (Dec. 99).

The Photon v2.0 display driver is designed around a common configuration include file called **S1D13705.h**, which is generated by the configuration utility 13705CFG. This design allows for easy customization of display type, clocks, decode addresses, etc. by OEMs. For further information on 13705CFG, see the *13705CFG Configuration Program User Manual*, document number X27A-B-001-xx.

### Note

The QNX display drivers are provided as “reference” source code only. They are intended to provide a basis for OEMs to develop their own drivers for QNX Photon v2.0.

This document and the source code for the QNX display drivers are updated as appropriate. Please check the Epson Electronics America website at <http://www.eea.epson.com> or the Epson Research and Development website at <http://www.erd.epson.com> for the latest revisions before beginning any development.

We appreciate your comments on our documentation. Please contact us via e-mail at [documentation@erd.epson.com](mailto:documentation@erd.epson.com).

## Building the Photon v2.0 Display Driver

The following steps build the Photon v2.0 display driver and integrate it into the QNX operating system. These instructions assume the QNX developer environment is correctly installed and the developer is familiar with building for the QNX operating system.

### Unpack the Graphics Driver Development Kit Archive

1. Install the QNX ddk package using the Package Manager utility.

For information about the Drivers Development Kit contact QNX directly.

2. Once the ddk package is installed, copy the directory tree /usr/src/gddk\_v1.0 into the Project directory.
3. Change directory to Project/gddk\_1.0/devg.
4. Unpack the display driver files using the commands:

```
#gunzip S1D13705.tar.gz
```

```
#tar -xvf S1D13705.tar
```

This unpacks the files into the directory Project/gddk\_1.0/devg/S1D13705.

### Configure the Driver

The file **s1d13705\_8.h** contains register values required to set the screen resolution, color depth (bpp), display type, etc. The **s1d13705.h** file included with the drivers may not contain applicable values and must be regenerated. The configuration program 13705CFG can be used to build new **s1d13705\_8.h** files.

#### Note

**S1d13705.h** should be created using the configuration utility 13705CFG. For more information on 13705CFG, see the *13705CFG Configuration Program User Manual*, document number X27A-B-001-xx available at [www.erd.epson.com](http://www.erd.epson.com).

### Build the Driver

The first time the driver is built, the following command ensures that all drivers and required libraries are built. At the root of the Project source tree, type **make**.

#### Note

To build drivers for X86 NTO type 'OSLIST=nto CPULIST=x86 make'.

Further builds do not require all libraries to be re-built. To build only the S1D13705 display driver, change to the directory gddk\_1.0/devg/S1D13705 and type **make**.

## Installing the Driver

The build step produces two library images:

- lib/disputil/nto/x86/so/libdisputil.so
- lib/ffb/nto/x86/so/libffb.so

For the loader to locate them, the files need to be renamed and copied to the lib directory.

1. Rename libdisputil.so to libdisputil.so.1 and libffb.so to libffb.so.1.
2. Copy the files new files libdisputil.so.1 and libffb.so.1 to the directory /usr/lib.
3. Copy the file devg-S1D13705.so to the /lib/dll directory.

### Note

To locate the file devg-S1D13705.so, watch the output of the 'true' command during the makefile build.

4. Modify the trap file graphics-modes in the /etc/system/config directory by inserting the following lines at the top of the file.

```
io-graphics -dldevg-S1D13705.so -g320x240x8 -I0 -d0x0,0x0;#320,240,8 Epson
```

## Run the Driver

### Note

For the remaining steps the S5U13705B00C evaluation board must be installed on the test platform.

### Note

Because this is an ISA board, a memory hole must be created in the 15 megabyte range. This is done in the BIOS settings.

It is recommended that the driver be verified **before starting QNX with the S1D13705 as the primary display**. To verify the driver:

1. Copy the data file from the services/graphics/tests/bench directory to the current directory. Use test8.raw for 8-bpp.

2. Type the following command at the root of the Project source tree (gddk\_v1.00 directory):

```
services/graphics/tests/bench/nto/x86/o/bench -dlhardware/devg/S1D13705/  
nto/x86/dll/devg-S1D13705.so -mW,H,C,F -d0x0,0x0
```

Where:

W is the configured width of the display  
H is the configured height of the display  
C is the color depth in bpp (i.e. 8)  
F is the configured frame rate

This command starts the bench utility which will initialize the driver as the secondary display and exercise the drivers main functions. If the display appears satisfactory, restart QNX Photon and the restart will result in the S1D13705 display driver becoming the primary display device.

## Comments

- To restore the display driver to the default, comment out changes made to the trap file graphics-trapfile.



# EPSON®



## S1D13XXX 32-Bit Windows Device Driver Installation Guide

Document No. X00A-E-003-04

Copyright © 1999, 2001 Epson Research and Development, Inc. All Rights Reserved.

Information in this document is subject to change without notice. You may download and use this document, but only for your own use in evaluating Seiko Epson/EPSON products. You may not modify the document. Epson Research and Development, Inc. disclaims any representation that the contents of this document are accurate or current. The Programs/Technologies described in this document may contain material protected under U.S. and/or International Patent laws.

EPSON is a registered trademark of Seiko Epson Corporation. All Trademarks are the property of their respective owners

---

**THIS PAGE LEFT BLANK**

# S1D13XXX 32-Bit Windows Device Driver Installation Guide

This manual describes the installation of the Windows 9x/ME/NT 4.0/2000 device drivers for the S5U13xxxB00x series of Epson Evaluation Boards.

The file S1D13XXX.VXD is required for using the Epson supplied Intel32 evaluation and test programs for the S1D13xxx family of LCD controllers with Windows 9x/ME.

The file S1D13XXX.SYS is required for using the Epson supplied Intel32 evaluation and test programs for the S1D13xxx family of LCD controllers with Windows NT 4.0/2000.

The file S1D13XXX.INF is the install script.

For updated drivers, ask your Sales Representative or visit Epson Electronics America on the World Wide Web at [www.eea.epson.com](http://www.eea.epson.com).

## Driver Requirements

<b>Video Controller</b>	: S1D13xxx
<b>Display Type</b>	: N/A
<b>BIOS</b>	: N/A
<b>DOS Program</b>	: No
<b>Dos Version</b>	: N/A
<b>Windows Program</b>	: Yes, Windows 9x/ME/NT 4.0/2000 device driver
<b>Windows DOS Box</b>	: N/A
<b>Windows Full Screen</b>	: N/A
<b>OS/2</b>	: N/A

## Installation

### Windows NT Version 4.0

All evaluation boards require the driver to be installed as follows.

1. Install the evaluation board in the computer and boot the computer.
2. Copy the files S1D13XXX.INF and S1D13XXX.SYS to a directory on a local hard drive.
3. Right click your mouse on the file S1D13XXX.INF and select INSTALL from the menu.
4. Windows will install the device driver and ask you to restart.

## Windows 2000

### All PCI Bus Evaluation Cards

1. Install the evaluation board in the computer and boot the computer.
2. Windows will detect the new hardware as a new PCI Device and bring up the FOUND NEW HARDWARE dialog box.
3. Click NEXT.
4. The New Hardware Wizard will bring up the dialog box to search for a suitable driver.
5. Click NEXT.
6. When Windows does not find the driver it will allow you to specify the location of it. Type the driver location or select BROWSE to find it.
7. Click NEXT.
8. Windows 2000 will open the installation file and show the option EPSON PCI Bridge Card. Select this file and click OPEN.
9. Windows then shows the path to the file. Click OK.
10. Click NEXT.
11. Click FINISH.

### All ISA Bus Evaluation Cards

1. Install the evaluation board in the computer and boot the computer.
2. Go to the CONTROL PANEL and select ADD/REMOVE HARDWARE, click NEXT.
3. Select ADD/TROUBLESHOOT A DEVICE, and click NEXT. Windows 2000 will attempt to detect any new plug and play device and fail.
4. The CHOOSE HARDWARE DEVICE dialog box appears. Select ADD NEW HARDWARE and click NEXT.
5. Select NO I WANT TO SELECT FROM A LIST and click NEXT.
6. Select OTHER DEVICE from the list and click NEXT.
7. Click HAVE DISK.
8. Specify the location of the driver files, select the S1D13XXX INF file and click OPEN.
9. Click OK.

---

## Windows 98/ME

### All PCI Bus Evaluation Cards

1. Install the evaluation board in the computer and boot the computer.
2. Windows will detect the new hardware as a new PCI Device and bring up the ADD NEW HARDWARE dialog box.
3. Click NEXT.
4. Windows will look for the driver. When Windows does not find the driver it will allow you to specify the location of it. Type the driver location or select BROWSE to find it.
5. Click NEXT.
6. Windows will open the installation file and show the option EPSON PCI Bridge Card.
7. Click FINISH.

### All ISA Bus Evaluation Cards

1. Install the evaluation board in the computer and boot the computer.
2. Go to the CONTROL PANEL and double-click on ADD NEW HARDWARE to launch the ADD NEW HARDWARE WIZARD. Click NEXT.
3. Windows will attempt to detect any new plug and play device and fail. Click NEXT.
4. Windows will ask you to let it detect the hardware, or allow you to select from a list. Select NO, I WANT TO SELECT THE HARDWARE FROM A LIST and click NEXT.
5. From the list select OTHER DEVICES and click NEXT.
6. Click HAVE DISK and type the path to the driver files, or select browse to find the driver.
7. Click OK.
8. The driver will be identified as EPSON PCI Bridge Card. Click NEXT.
9. Click FINISH.

## Windows 95 OSR2

### All PCI Bus Evaluation Cards

1. Install the evaluation board in the computer and boot the computer.
2. Windows will detect the card as a new PCI Device and launch the UPDATE DEVICE DRIVER wizard.

#### If The Driver is on Floppy Disk

3. Place the disk into drive A: and click NEXT.
4. Windows will find the EPSON PCI Bridge Card.
5. Click FINISH to install the driver.
6. Windows will ask you to restart the system.

#### If The Driver is not on Floppy Disk

3. Click NEXT, Windows will search the floppy drive and fail.
4. Windows will attempt to load the new hardware as a Standard VGA Card.
5. Click CANCEL. The Driver must be loaded from the CONTROL PANEL under ADD/NEW HARDWARE.
6. Select NO for Windows to DETECT NEW HARDWARE.
7. Click NEXT.
8. Select OTHER DEVICES from HARDWARE TYPE and Click NEXT.
9. Click HAVE DISK.
10. Specify the location of the driver and click OK.
11. Click OK.
12. EPSON PCI Bridge Card will appear in the list.
13. Click NEXT.
14. Windows will install the driver.
15. Click FINISH.
16. Windows will ask you to restart the system.
17. Windows will re-detect the card and ask you to restart the system.

---

## All ISA Bus Evaluation Cards

1. Install the evaluation board in the computer and boot the computer.
2. Go to the CONTROL PANEL and select ADD NEW HARDWARE.
3. Click NEXT.
4. Select NO and click NEXT.
5. Select OTHER DEVICES and click NEXT.
6. Click Have Disk.
7. Specify the location of the driver files and click OK.
8. Click Next.
9. Click Finish.

## Previous Versions of Windows 95

### All PCI Bus Evaluation Cards

1. Install the evaluation board in the computer and boot the computer.
2. Windows will detect the card.
3. Select DRIVER FROM DISK PROVIDED BY MANUFACTURER.
4. Click OK.
5. Specify a path to the location of the driver files.
6. Click OK.
7. Windows will find the S1D13XXX.INF file.
8. Click OK.
9. Click OK and Windows will install the driver.

## All ISA Bus Evaluation Cards

1. Install the evaluation board in the computer and boot the computer.
2. Go to the CONTROL PANEL and select ADD NEW HARDWARE.
3. Click NEXT.
4. Select NO and click NEXT.
5. Select OTHER DEVICES from the HARDWARE TYPES list.
6. Click HAVE DISK.
7. Specify the location of the driver files and click OK.
8. Select the file S1D13XXX.INF and click OK.
9. Click OK.
10. The EPSON PCI Bridge Card should be selected in the list window.
11. Click NEXT.
12. Click NEXT.
13. Click Finish.





**S1D13705 Embedded Memory LCD Controller**

# **S5U13705B00C Rev. 1.0 ISA Bus Evaluation Board User Manual**

**Document Number: X27A-G-005-03**

Copyright © 1999, 2001 Epson Research and Development, Inc. All Rights Reserved.

Information in this document is subject to change without notice. You may download and use this document, but only for your own use in evaluating Seiko Epson/EPSON products. You may not modify the document. Epson Research and Development, Inc. disclaims any representation that the contents of this document are accurate or current. The Programs/Technologies described in this document may contain material protected under U.S. and/or International Patent laws.

EPSON is a registered trademark of Seiko Epson Corporation. All other trademarks are the property of their respective owners.

---

**THIS PAGE LEFT BLANK**

# Table of Contents

<b>1</b>	<b>Introduction</b>	<b>7</b>
1.1	Features	7
<b>2</b>	<b>Installation and Configuration</b>	<b>8</b>
<b>3</b>	<b>LCD Interface Pin Mapping</b>	<b>10</b>
<b>4</b>	<b>CPU/Bus Interface Connector Pinouts</b>	<b>11</b>
<b>5</b>	<b>Host Bus Interface Pin Mapping</b>	<b>13</b>
<b>6</b>	<b>Technical Description</b>	<b>14</b>
6.1	Embedded Memory Support	14
6.2	ISA Bus Support	15
6.2.1	Display Adapter Card Support	15
6.2.2	Expanded Memory Manager Support	15
6.3	Non-ISA Bus Support	15
6.4	Decoding Logic	16
6.5	Clock Input Support	16
6.6	LCD Panel Voltage Setting	17
6.7	Monochrome LCD Panel Support	17
6.8	Color Passive LCD Panel Support	17
6.9	Color TFT/D-TFD LCD Panel Support	17
6.10	Power Save Modes	17
6.11	Adjustable LCD Panel Negative Power Supply	18
6.12	Adjustable LCD Panel Positive Power Supply	18
6.13	CPU/Bus Interface Header Strips	18
<b>7</b>	<b>Parts List</b>	<b>19</b>
<b>8</b>	<b>Schematic Diagrams</b>	<b>20</b>

**THIS PAGE LEFT BLANK**

---

## List of Tables

Table 2-1: Configuration DIP Switch Settings . . . . .	8
Table 2-2: Host Bus Selection . . . . .	8
Table 2-3: Jumper Settings . . . . .	9
Table 3-1: LCD Signal Connector (J5) Pinout . . . . .	10
Table 4-1: CPU/BUS Connector (H1) Pinout . . . . .	11
Table 4-2: CPU/BUS Connector (H2) Pinout . . . . .	12
Table 5-1: Host Bus Interface Pin Mapping . . . . .	13

## List of Figures

Figure 8-1: S1D13705B00C Schematic Diagram (1 of 4) . . . . .	20
Figure 8-2: S1D13705B00C Schematic Diagram (2 of 4) . . . . .	21
Figure 8-3: S1D13705B00C Schematic Diagram (3 of 4) . . . . .	22
Figure 8-4: S1D13705B00C Schematic Diagram (4 of 4) . . . . .	23

**THIS PAGE LEFT BLANK**

# 1 Introduction

This manual describes the setup and operation of the S5U13705B00C Rev. 1.0 Evaluation Board. Implemented using the S1D13705 Embedded Memory Color LCD Controller, the S5U13705B00C board is designed for the 16-bit ISA bus environment. To accommodate other bus architectures, the S5U13705B00C board also provides CPU/Bus interface connectors.

For more information regarding the S1D13705, refer to the S1D13705 Hardware Functional Specification, document number X27A-A-001-xx.

## 1.1 Features

- 80-pin QFP14 package.
- SMT technology for all appropriate devices.
- 4/8-bit monochrome and color passive LCD panel support.
- 9/12-bit LCD TFT/D-TFD panel support.
- Selectable 3.3V or 5V LCD panel support.
- Oscillator support for CLKI (up to 50MHz with internal clock divider or 25MHz with no internal clock divider).
- Embedded 80K byte SRAM display buffer for 1/2/4 bit-per-pixel (bpp), 2/4/16-level gray shade display and 1/2/4/8 bpp, 2/4/16/256 level color display.
- Support for software and hardware power save modes.
- On-board adjustable LCD bias positive power supply (+23V to +40V).
- On-board adjustable LCD bias negative power supply (-23V to -14V).
- 16-bit ISA bus support.
- CPU/Bus interface header strips for non-ISA bus support.

## 2 Installation and Configuration

The S1D13705 has four configuration inputs, CNF[3:0], which are read on the rising edge of RESET# and are fully configurable on this evaluation board. One six-position DIP switch is provided on the board to configure the four configuration inputs, select the S5U13705B00C memory/register start address, and enable/disable hardware power save mode.

The following settings are recommended when using the S5U13705B00C with the ISA bus.

*Table 2-1: Configuration DIP Switch Settings*

Switch	Signal	Closed (0 or low)	Open (1 or high)
S1-1	CNF0	See "Host Bus Selection" table below	See "Host Bus Selection" table below
S1-2	CNF1		
S1-3	CNF2		
S1-4	CNF3	Little Endian	Big Endian
S1-5	ADDR	Memory/Register Start Address = C0000h	Memory/Register Start Address = F00000h
S1-6	GPIO0	Hardware Suspend Disable	Hardware Suspend Enable

= recommended settings (configured for ISA bus support)

*Table 2-2: Host Bus Selection*

S1-3	S1-2	S1-1	BS#	Host Bus Interface
0	0	0	X	SH-4 bus interface
0	0	1	X	SH-3 bus interface
0	1	0	X	reserved
0	1	1	X	MC68K bus interface #1, 16-bit
1	0	0	X	reserved
1	0	1	X	MC68K bus interface #2, 16-bit
1	1	0	0	reserved
1	1	0	1	reserved
1	1	1	0	Generic #1, 16-bit
1	1	1	1	Generic #2, 16-bit

= recommended settings (configured for ISA bus support)



*Table 2-3: Jumper Settings*

	<b>Description</b>	<b>1-2</b>	<b>2-3</b>
JP1	IOVDD Selection	5.0V IOVDD	3.3V IOVDD
JP2	RD/WR# Signal Selection	Pulled up to IOVDD	No Connection
JP3	BS# Signal Selection	Pulled up to IOVDD	No Connection
JP4	LCD Panel Voltage Selection	5V LCD Panel	3.3V LCD Panel
JP6	LCDPWR polarity	Active low ('LCDPWR#')	Active high ('LCDPWR')

 = recommended settings (JP1 through JP3 configured for ISA bus support)

### 3 LCD Interface Pin Mapping

Table 3-1: LCD Signal Connector (J5) Pinout

Connector		Single Passive Panel					Dual Passive Panel		Color TFT/D-TFD	
Pin Name	Pin #	Color			Mono		Color	Mono	9-bit	12-bit
		4-bit	8-bit	8-bit Alternate Format	4-bit	8-bit	8-bit	8-bit		
BFPDAT0	1	driven 0	D0	LD0	driven 0	D0	D0	LD0	R2	R3
BFPDAT1	3	driven 0	D1	LD1	driven 0	D1	D1	LD1	R1	R2
BFPDAT2	5	driven 0	D2	LD2	driven 0	D2	D2	LD2	R0	R1
BFPDAT3	7	driven 0	D3	LD3	driven 0	D3	D3	LD3	G2	G3
BFPDAT4	9	D0	D4	UD0	D0	D4	D4	UD0	G1	G2
BFPDAT5	11	D1	D5	UD1	D1	D5	D5	UD1	G0	G1
BFPDAT6	13	D2	D6	UD2	D2	D6	D6	UD2	B2	B3
BFPDAT7	15	D3	D7	UD3	D3	D7	D7	UD3	B1	B2
BFPDAT8	17	GPIO1	GPIO1	GPIO1	GPIO1	GPIO1	GPIO1	GPIO1	B0	B1
BFPDAT9	19	GPIO2	GPIO2	GPIO2	GPIO2	GPIO2	GPIO2	GPIO2	GPIO2	R0
BFPDAT10	21	GPIO3	GPIO3	GPIO3	GPIO3	GPIO3	GPIO3	GPIO3	GPIO3	G0
BFPDAT11	23	GPIO4/ Inverse Video	GPIO4/ Inverse Video	GPIO4/ Inverse Video	GPIO4/ Inverse Video	GPIO4/ Inverse Video	GPIO4/ Inverse Video	GPIO4/ Inverse Video	GPIO4	B0
BFPSHIFT	33	FPSHIFT	FPSHIFT	FPSHIFT	FPSHIFT	FPSHIFT	FPSHIFT	FPSHIFT	FPSHIFT	FPSHIFT
BFPSHIFT2	35		FPSHIFT2							
BFPLINE	37	FPLINE	FPLINE	FPLINE	FPLINE	FPLINE	FPLINE	FPLINE	FPLINE	FPLINE
BFPFRAME	39	FPFRAME	FPFRAME	FPFRAME	FPFRAME	FPFRAME	FPFRAME	FPFRAME	FPFRAME	FPFRAME
GND	2-26 (Even Pins)	GND	GND	GND	GND	GND	GND	GND	GND	GND
N / C	28									
VLCD	30	LCD panel negative bias voltage (-24V to -14V)								
LCDVCC	32	+3.3V or +5V (selectable with JP4)								
+12V	34	+12V	+12V	+12V	+12V	+12V	+12V	+12V	+12V	+12V
VDDH	36	LCD panel positive bias voltage (+23V to +40V)								
BDRDY	38	MOD		MOD	MOD	MOD	MOD	MOD	DRDY	DRDY
BLCDPWR	40	LCDPWR	LCDPWR	LCDPWR	LCDPWR	LCDPWR	LCDPWR	LCDPWR	LCDPWR	LCDPWR

#### Note

1. Un-used GPIO pins must be connected to IO  $V_{DD}$ .
2. Inverse Video is enabled on FPDAT11 by REG[02h] bit 1.

## 4 CPU/Bus Interface Connector Pinouts

Table 4-1: CPU/BUS Connector (H1) Pinout

Connector Pin No.	CPU/BUS Pin Name	Comments
1	SD0	Connected to DB0 of the S1D13705
2	SD1	Connected to DB1 of the S1D13705
3	SD2	Connected to DB2 of the S1D13705
4	SD3	Connected to DB3 of the S1D13705
5	GND	Ground
6	GND	Ground
7	SD4	Connected to DB4 of the S1D13705
8	SD5	Connected to DB5 of the S1D13705
9	SD6	Connected to DB6 of the S1D13705
10	SD7	Connected to DB7 of the S1D13705
11	GND	Ground
12	GND	Ground
13	SD8	Connected to DB8 of the S1D13705
14	SD9	Connected to DB9 of the S1D13705
15	SD10	Connected to DB10 of the S1D13705
16	SD11	Connected to DB11 of the S1D13705
17	GND	Ground
18	GND	Ground
19	SD12	Connected to DB12 of the S1D13705
20	SD13	Connected to DB13 of the S1D13705
21	SD14	Connected to DB14 of the S1D13705
22	SD15	Connected to DB15 of the S1D13705
23	RESET#	Connected to the RESET# signal of the S1D13705
24	GND	Ground
25	GND	Ground
26	GND	Ground
27	+12V	12 volt supply
28	+12V	12 volt supply
29	WE0#	Connected to the WE0# signal of the S1D13705
30	WAIT#	Connected to the WAIT# signal of the S1D13705
31	CS#	Connected to the CS# signal of the S1D13705
32	NC	Not connected
33	WE1#	Connected to the WE1# signal of the S1D13705
34	IOVDD	Connected to the IOVDD supply of the S1D13705

Table 4-2: CPU/BUS Connector (H2) Pinout

Connector Pin No.	CPU/BUS Pin Name	Comments
1	SA0	Connected to AB0 of the S1D13705
2	SA1	Connected to AB1 of the S1D13705
3	SA2	Connected to AB2 of the S1D13705
4	SA3	Connected to AB3 of the S1D13705
5	SA4	Connected to AB4 of the S1D13705
6	SA5	Connected to AB5 of the S1D13705
7	SA6	Connected to AB6 of the S1D13705
8	SA7	Connected to AB7 of the S1D13705
9	GND	Ground
10	GND	Ground
11	SA8	Connected to AB8 of the S1D13705
12	SA9	Connected to AB9 of the S1D13705
13	SA10	Connected to AB10 of the S1D13705
14	SA11	Connected to AB11 of the S1D13705
15	SA12	Connected to AB12 of the S1D13705
16	SA13	Connected to AB13 of the S1D13705
17	GND	Ground
18	GND	Ground
19	SA14	Connected to AB14 of the S1D13705
20	SA15	Connected to AB14 of the S1D13705
21	SA16	Connected to AB16 of the S1D13705
22	SA17	Connected to SA17 of the ISA bus connector
23	SA18	Connected to SA18 of the ISA bus connector
24	SA19	Connected to SA19 of the ISA bus connector
25	GND	Ground
26	GND	Ground
27	VCC	5 volt supply
28	VCC	5 volt supply
29	RD/WR#	Connected to the R/W# signal of the S1D13705
30	BS#	Connected to the BS# signal of the S1D13705
31	BUSCLK	Connected to the BCLK signal of the S1D13705
32	RD#	Connected to the RD# signal of the S1D13705
33	NC	Not connected
34	CLKI	Connected to the CLKI signal of the S1D13705

## 5 Host Bus Interface Pin Mapping

Table 5-1: Host Bus Interface Pin Mapping

S1D13705 Pin Names	SH-3	SH-4	MC68K #1	MC68K #2	Generic Bus #1	Generic Bus #2
AB[16:1]	A[16:1]	A[16:1]	A[16:1]	A[16:1]	A[16:1]	A[16:1]
AB0	A0	A0	LDS#	A0	A0	A0
DB[15:0]	D[15:0]	D[15:0]	D[15:0]	D[15:0]	D[15:0]	D[15:0]
WE1#	WE1#	WE1#	UDS#	DS#	WE1#	BHE#
CS#	CSn#	CSn#	External Decode	External Decode	External Decode	External Decode
BCLK	CKIO	CKIO	BCLK	BCLK	BCLK	BCLK
BS#	BS#	BS#	AS#	AS#	Connect to V <sub>SS</sub>	Connect to IO V <sub>DD</sub>
RD/WR#	RD/WR#	RD/WR#	R/W#	R/W#	RD1#	Connect to IO V <sub>DD</sub>
RD#	RD#	RD#	Connect to IO V <sub>DD</sub>	SIZ1	RD0#	RD#
WE0#	WE0#	WE0#	Connect to IO V <sub>DD</sub>	SIZ0	WE0#	WE#
WAIT#	WAIT#	RDY#	DTACK#	DSACK1#	WAIT#	WAIT#
RESET#	RESET#	RESET#	RESET#	RESET#	RESET#	RESET#

## 6 Technical Description

### 6.1 Embedded Memory Support

The S1D13705 contains 80K bytes of embedded, 16-bit, SRAM used for the display buffer and a 32 byte internal register set.

Since the S1D13705 does not distinguish between memory and register accesses, both the 80K byte display buffer and the 32 byte register set must be memory mapped into the host's memory space.

When using the S5U13705B00C board on an ISA bus system, the board can be configured to map the S1D13705 to one of two memory blocks.

The SRAM start address is determined by a DIP switch setting. See Table 2-1: "Configuration DIP Switch Settings," on page 8.

1. When switch S1-5 is in the closed position, the S1D13705 is mapped into segments 0C0000h and 0D0000h.

This memory space is in the first 1M byte of ISA bus memory and should be used if these segments are not taken up by other devices such as network adapters, SCSI cards, or other peripherals.

#### Note

Since VGA and VGA compatible video adapters use address 0C8000, these cards cannot be used while using the S5U13705B00C board at this memory address. A monochrome display adapter, a terminal, or a non-VGA compatible display adapter must be used.

2. When switch S1-5 is in the open position, the S1D13705 is mapped into the upper megabyte of ISA bus memory, starting address of F00000h. To use this memory on an ISA bus system, the system BIOS has to be configured to set a memory 'hole' starting at this address. Some systems allow the user to configure the size of this hole and the starting address of where it begins while others just allow a 1M byte hole at the top of the 16M byte memory space. This memory hole is configured by entering the system CMOS Setup Utility. This memory space should be used if segments 0Dh and 0Eh are being used by other devices or if a VGA display adapter is needed.

Starting at the SRAM start address, the board design decodes a 128K byte segment accommodating both the 80K byte display buffer and the S1D13705 internal register set. The S1D13705 registers are mapped into the upper 32 bytes of the 128K byte segment (1FFE0h to 1FFFFh).

When using the S5U13705B00C board on a non-ISA bus system, system or external decode logic must map the S1D13705 into an appropriate memory space.

## 6.2 ISA Bus Support

The S5U13705B00C board has been designed to directly support the 16-bit ISA bus environment and can be used in conjunction with either a VGA or a monochrome display adapter card.

There are 4 configuration inputs associated with the Host Interface (CNF[2:0] and BS#). Refer to Table 2-3: “Jumper Settings,” on page 9 and Table 5-1: “Host Bus Interface Pin Mapping,” on page 13 for complete details.

### 6.2.1 Display Adapter Card Support

When using the S5U13705B00C in conjunction with another primary Display Adapter (VGA or Monochrome) the following applies:

#### VGA Display Adapter

All VGA display adapters can be used with the S5U13705B00C board if the S1D13705 is mapped to the upper 1M Byte of ISA bus memory, address F00000-F1FFFF. If the S1D13705 is mapped to the address range 0C0000-0D0000, then no VGA or VGA compatible display adapters can be used with the S5U13705B00C board. See Embedded Memory Support on page 14.

#### Monochrome Display Adapter

The S5U13705B00C board can be used with monochrome display adapters at both memory addresses.

### 6.2.2 Expanded Memory Manager Support

If a memory manager is being used for system memory, the address range selected for the SRAM start address must be excluded from use or memory conflicts will arise.

## 6.3 Non-ISA Bus Support

The S5U13705B00C board is specifically designed to support the standard 16-bit ISA bus. However, the S1D13705 directly supports many other host bus interfaces. Header strips H1 and H2 are provided and contain all the necessary IO pins to interface to these host buses. See CPU/Bus Interface Connector Pinouts on page 11; Table 2-1: “Configuration DIP Switch Settings,” on page 8; and Table 2-3: “Jumper Settings,” on page 9 for details.

When using the header strips to provide the bus interface observe the following:

- All signals on the ISA bus card edge must be isolated from the ISA bus (do not plug the card into a computer). Power must be provided through the headers.
- U7, a PLD of type 22V10-15, is used to provide the S1D13705 CS# (pin 74) and other decoding logic signals for ISA bus mode. For non-ISA applications, this functionality must be provided externally. Remove the PAL from its socket to eliminate conflicts driving S1D13705 control signals. Refer to Table 5-1: “Host Bus Interface Pin Mapping” for connection details.

**Note**

When using a 3.3V host bus interface, IO  $V_{DD}$  must be set to 3.3V by setting jumper (JP1) to the 2-3 position. Refer to Table 2-3: “Jumper Settings,” on page 9.

## 6.4 Decoding Logic

All the required decode logic is provided through a PLD of type 22V10-15 (U7, socketed). This PAL contains the following equations.

```
!CS      = (Address >= ^hC0000) & (Address <= ^hDFFFF) & !ADDR & REFRESH & ENAB
          # (Address1 >= ^hF00000) & (Address1 <= ^hF1FFFF) & ADDR & REFRESH & ENAB;

!MEMCS16 = (Address1 >= ^h0C0000) & (Address1 <= ^h0DFFFF) & !ADDR & !CS
          # (Address1 >= ^hF00000) & (Address1 <= ^hF1FFFF) & ADDR & !CS;

!WE0     = (!CS & !ADDR & !SMEMW) # (!CS & ADDR & !MEMW);

!RD      = (!CS & !ADDR & !SMEMR) # (!CS & ADDR & !MEMR);
```

**Note**

ADDR = Switch S1-5 (see Table 2-1: “Configuration DIP Switch Settings,” on page 8).

## 6.5 Clock Input Support

The input clock (CLKI) frequency can be up to 50MHz for the S1D13705 if the internal clock divide-by-2 mode is set. If the clock divider is not used, the maximum CLKI frequency is 25MHz. There is no minimum input clock frequency.

A 25.0MHz oscillator (U2, socketed) is provided as the input clock source. However, depending on the LCD resolution, desired frame rate, and power consumption budget, a lower frequency clock may be required.



## 6.6 LCD Panel Voltage Setting

The S5U13705B00C board supports both 3.3V and 5V LCD panels through the LCD connector J5. The voltage level is selected by setting jumper J4 to the appropriate position. Refer to Table 2-3: “Jumper Settings,” on page 9 for setting this jumper.

Although not necessary for signal buffering, buffers have been implemented in the board design to provide flexibility in handling 3 and 5 volt panels.

## 6.7 Monochrome LCD Panel Support

The S1D13705 directly supports 4 and 8-bit, dual and single, monochrome passive LCD panels. All necessary signals are provided on the 40-pin ribbon cable header J5. The interface signals on the cable are alternated with grounds to reduce crosstalk and noise.

Refer to Table 3-1: “LCD Signal Connector (J5) Pinout,” on page 10 for specific connection information.

## 6.8 Color Passive LCD Panel Support

The S1D13705 directly supports 4 and 8-bit, dual and single, color passive LCD panels. All the necessary signals are provided on the 40-pin ribbon cable header J5. The interface signals on the cable are alternated with grounds to reduce crosstalk and noise.

Refer to Table 3-1: “LCD Signal Connector (J5) Pinout,” on page 10 for specific connection information.

## 6.9 Color TFT/D-TFD LCD Panel Support

The S1D13705 directly supports 9 and 12-bit active matrix color TFT/D-TFD panels. All the necessary signals can also be found on the 40-pin LCD connector J5. The interface signals on the cable are alternated with grounds to reduce crosstalk and noise.

Refer to Table 3-1: “LCD Signal Connector (J5) Pinout,” on page 10 for connection information.

## 6.10 Power Save Modes

The S1D13705 supports hardware and software power save modes. These modes are controlled by the utility 13705PWR. The hardware power save mode needs to be enabled by 13705PWR and then activated by DIP switch S1-6. See Table 2-1: “Configuration DIP Switch Settings,” on page 8 for details on setting this switch.

## 6.11 Adjustable LCD Panel Negative Power Supply

For those LCD panels requiring a negative power supply to provide between -23V and -14V ( $I_{out}=25mA$ ) a power supply has been provided as an integral part of this design. The VLCD power supply can be adjusted by R21 to give an output voltage from -23V to -14V, and is enabled and disabled by the active high S1D13705 control signal LCDPWR, inverted externally.

Determine the panel's specific power requirements and set the potentiometer accordingly before connecting the panel.

## 6.12 Adjustable LCD Panel Positive Power Supply

For those LCD panels requiring a positive power supply to provide between +23V and +40V ( $I_{out}=45mA$ ) a power supply has been provided as an integral part of this design. The VDDH power supply can be adjusted by R15 to provide an output voltage from +23V to +40V and is enabled and disabled by the active high S1D13705 control signal LCDPWR, inverted externally.

Determine the panel's specific power requirements and set the potentiometer accordingly before connecting the panel.

## 6.13 CPU/Bus Interface Header Strips

All of the CPU/Bus interface pins of the S1D13705 are connected to the header strips H1 and H2 for easy interface to a CPU/Bus other than ISA.

Refer to Table 4-1: "CPU/BUS Connector (H1) Pinout," on page 11 and Table 4-2: "CPU/BUS Connector (H2) Pinout," on page 12 for specific settings.

### Note

These headers only provide the CPU/bus interface signals from the S1D13705. When another host bus interface is selected by CNF[3:0] and BS#, appropriate external decoding logic MUST be used to access the S1D13705. Refer to Table 5-1: "Host Bus Interface Pin Mapping," on page 13 for connection details.

## 7 Parts List

Item #	Qty/board	Designation	Part Value	Description
1	15	C1-C11, C15-17,C24	0.1uF, 20%, 50V	0805 ceramic capacitor
2	3	C12-14	10uF, 10%, 25V	Tantalum capacitor size D
3	2	C18, C22	47uF, 10%, 16V	Tantalum capacitor size D
4	3	C19-C21	4.7uF, 10%, 50V	Tantalum capacitor size D
5	1	C23	56uF, 20%, 63V	Electrolytic, radial, low ESR
6	2	H1,H2	CON34A Header	0.1" 17x2 header, PTH
7	5	JP1-JP4, JP6	HEADER 3	0.1" 1x3 header, PTH
8	1	J1	AT CON-A	ISA Bus gold fingers
9	1	J2	AT CON-B	ISA Bus gold fingers
10	1	J3	AT CON-C	ISA Bus gold fingers
11	1	J4	AT CON-D	ISA Bus gold fingers
12	1	J5	CON40A	Shrouded header 2x20, PTH, center key
13	1	L1	1µH	MCI-1812 inductor
14	2	L3, L4	Ferrite bead	Philips BDS3/3/8.9-4S2
15	1	Q1	2N3906	PNP signal transistor, SOT23
16	1	Q2	2N3904	NPN signal transistor, SOT23
17	6	R1-R6	15K, 5%	0805 resistor
18	9	R7-R13, R17, R18	10K, 5%	0805 resistor
19	1	R14	475K, 1%	0805 resistor
20	1	R15	200K Pot.	200K Trim POT Spectrol 63S204T607 (or equivalent)
21	1	R16	14K, 1%	0805 resistor
22	3	R19, R20, R22	100K, 5%	0805 resistor
23	1	R21	100K Pot.	100K Trim POT Spectrol 63S104T607 (or equivalent)
24	1	S1	SW DIP-6	6 position DIP switch
25	1	U1	S1D13705F00A	QFP14-80, 80 pin, SMT
26	1	U2	25.0 MHz oscillator	FOX 25MHz oscillator or equiv., 14 pin DIP socketed
27	3	U3-U5	74AHC244	SO-22, TI74AHC244
28	1	U6	LT1117CM-3.3	Linear Technology 5V to 3.3V regulator, 800mA
29	1	U7	PLD22V10-15	PLD type 22V10-15, 20 Pin DIP, socketed
30	1	U8	74ALS125	SO-14, 74ALS125
31	1	U9	74HCT04	SO-14, 74HCT04
32	1	U10	RD-0412	Xentek RD-0412, positive PS
33	1	U11	EPN001	Xentek EPN001 negative PS

# 8 Schematic Diagrams

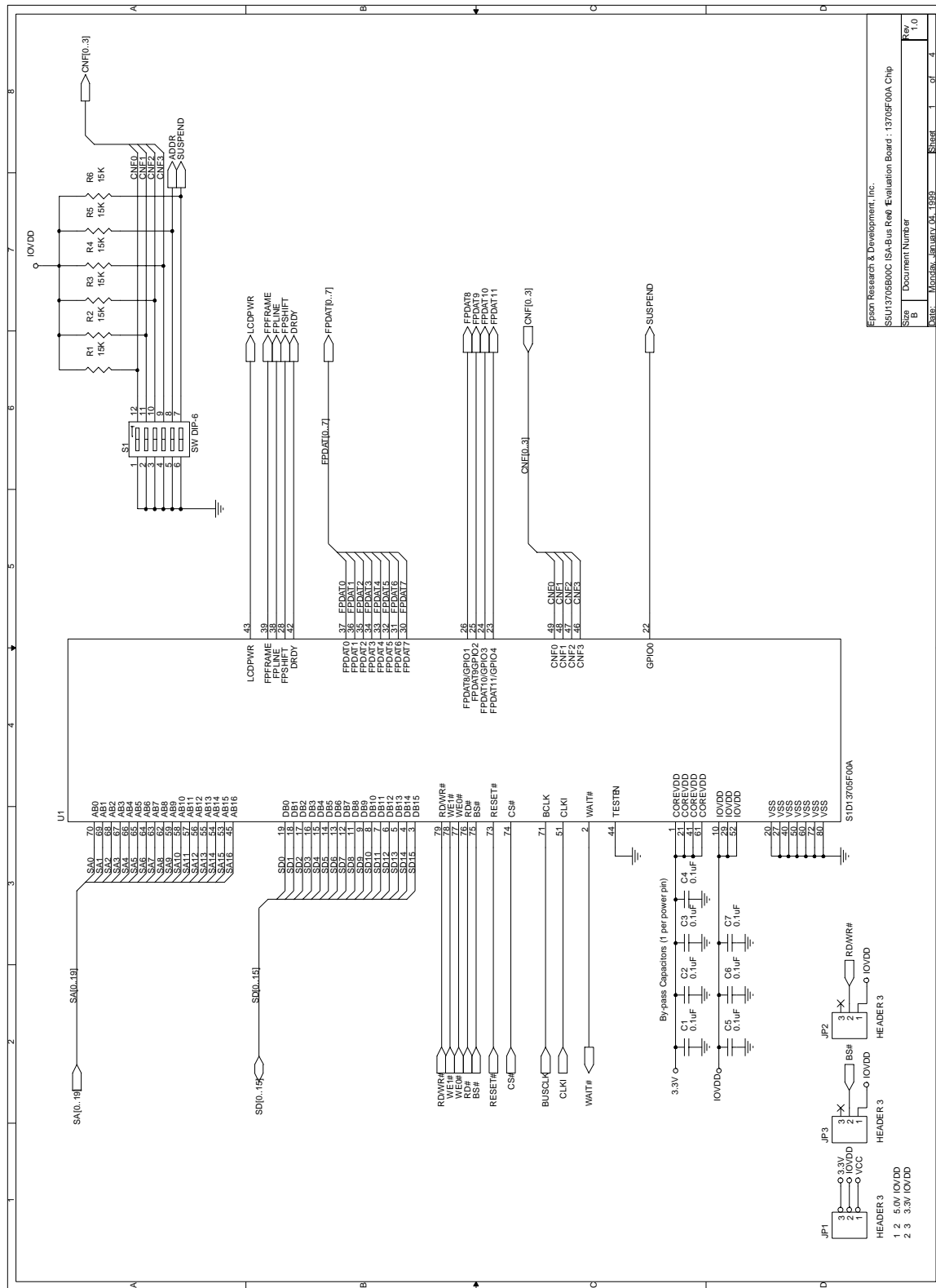
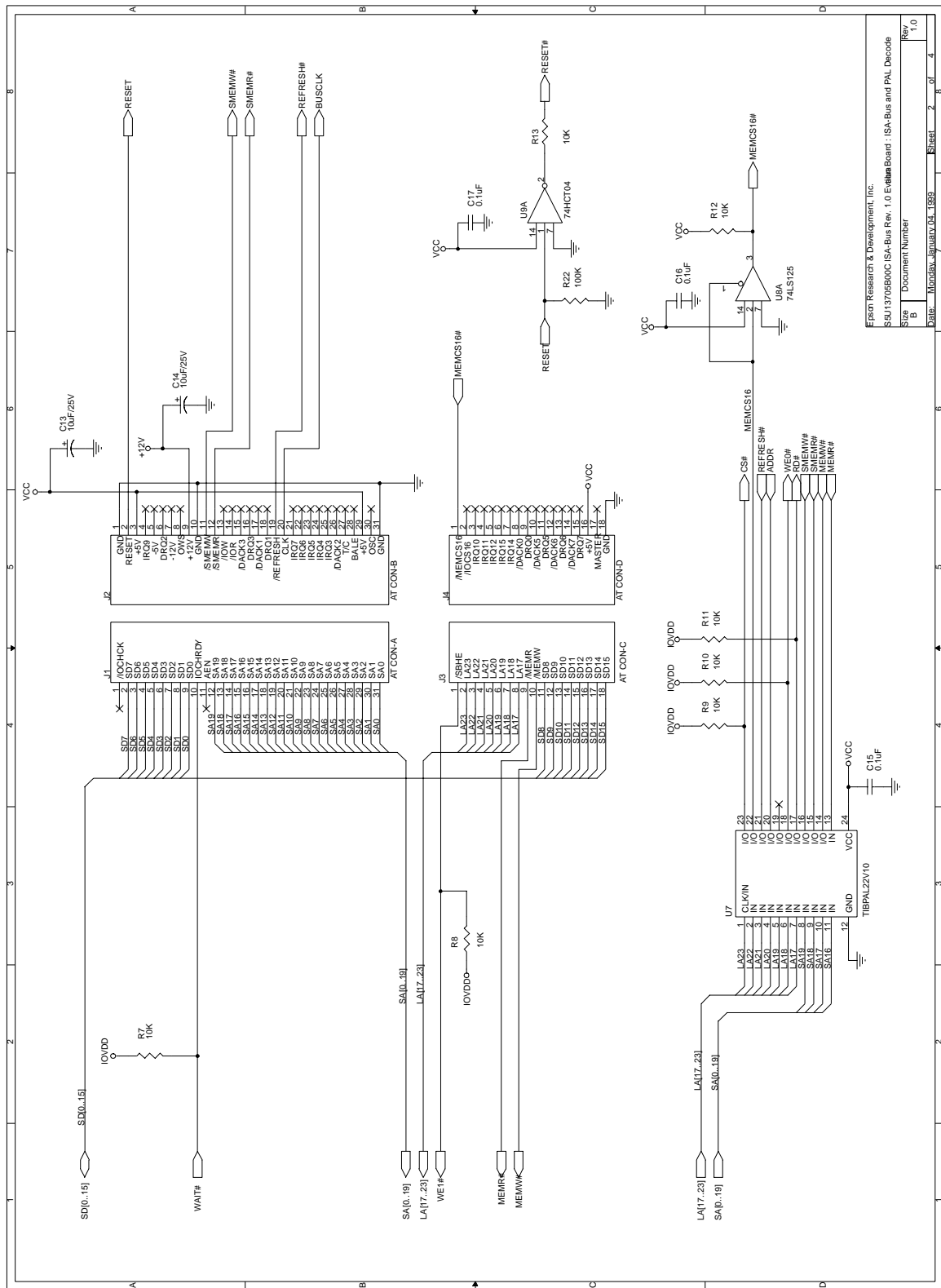

Figure 8-1: S1D13705B00C Schematic Diagram (1 of 4)



Epson Research & Development, Inc.  
S5U13705B00C ISA Bus Rev. 1.0 Evaluation Board : ISA Bus and PAL Decode  
Document Number :  
Date: Monday, January 04, 1999 Sheet 2 of 4  
Rev 1.0

Figure 8-2: SID13705B00C Schematic Diagram (2 of 4)

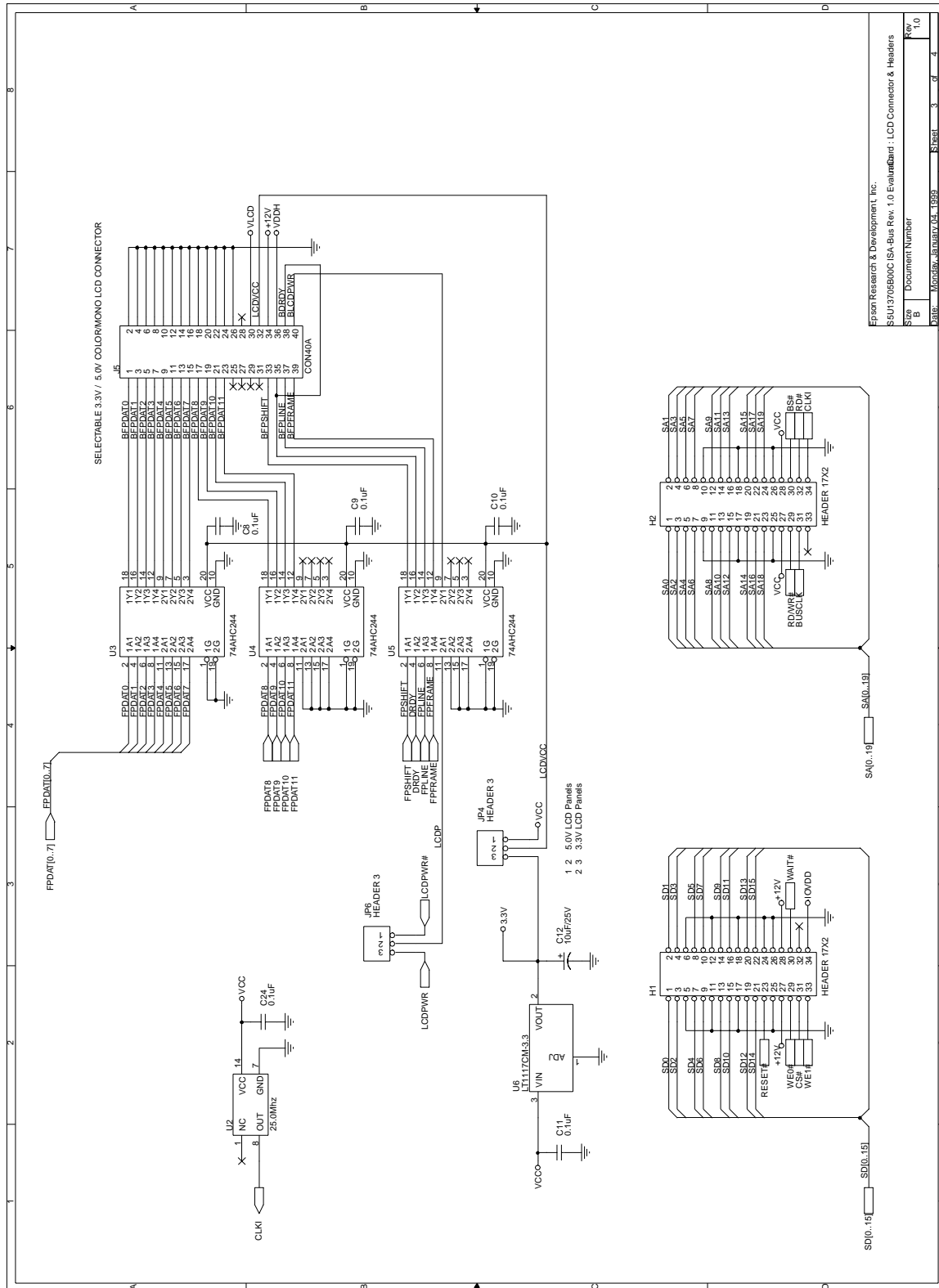

Figure 8-3: SID13705B00C Schematic Diagram (3 of 4)

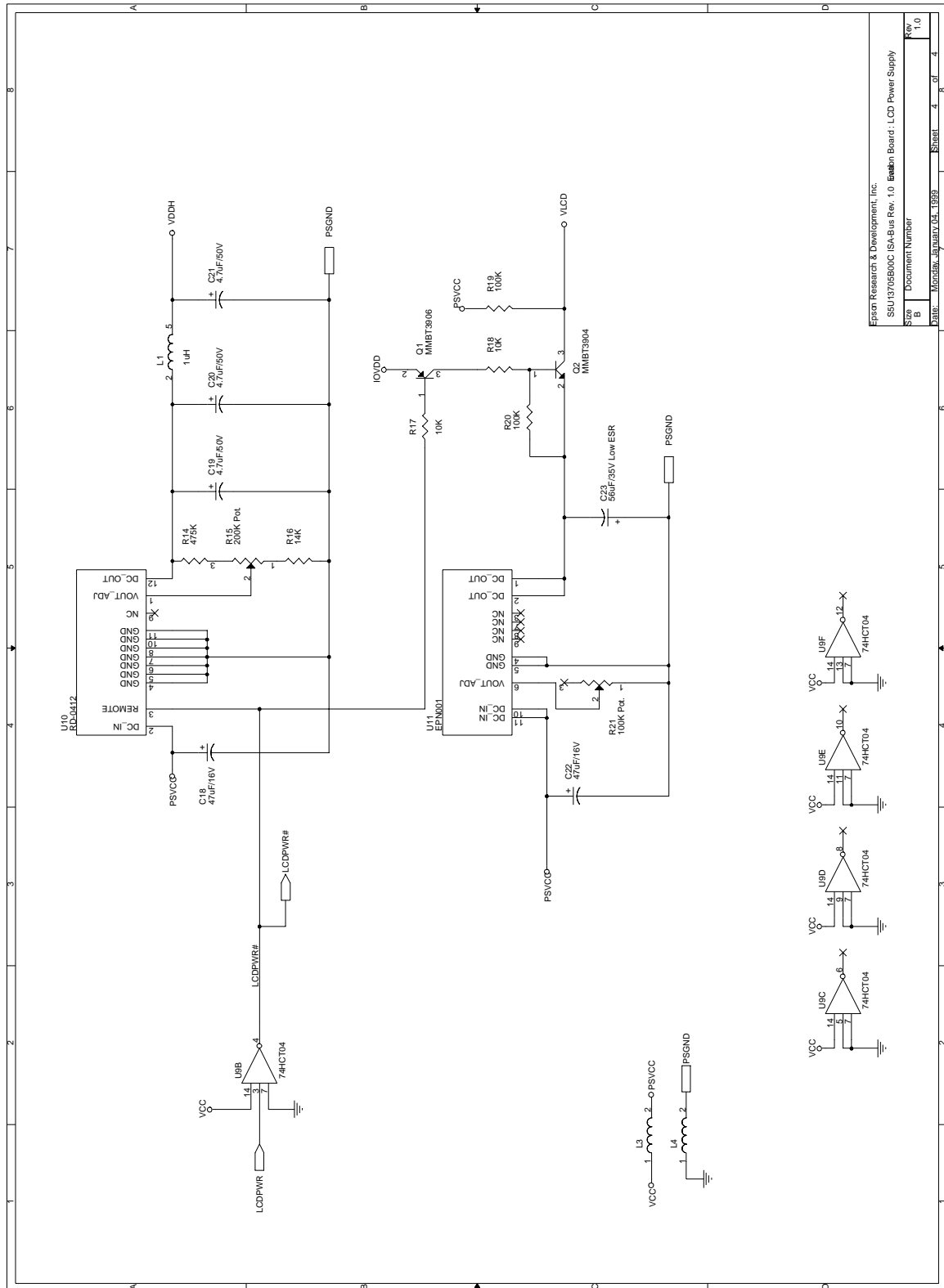

Figure 8-4: SID13705B00C Schematic Diagram (4 of 4)

**THIS PAGE LEFT BLANK**



# EPSON®



**S1D13705 Embedded Memory LCD Controller**

## **S5U13705B00C Rev. 2.0 Evaluation Board User Manual**

**Document Number: X27A-G-014-02**

Copyright © 2001 Epson Research and Development, Inc. All Rights Reserved.

Information in this document is subject to change without notice. You may download and use this document, but only for your own use in evaluating Seiko Epson/EPSON products. You may not modify the document. Epson Research and Development, Inc. disclaims any representation that the contents of this document are accurate or current. The Programs/Technologies described in this document may contain material protected under U.S. and/or International Patent laws.

EPSON is a registered trademark of Seiko Epson Corporation. All other trademarks are the property of their respective owners.

---

**THIS PAGE LEFT BLANK**

# Table of Contents

<b>1</b>	<b>Introduction</b>	<b>7</b>
<b>2</b>	<b>Features</b>	<b>8</b>
<b>3</b>	<b>Installation and Configuration</b>	<b>9</b>
3.1	Configuration DIP Switches	9
3.2	Configuration Jumpers	11
<b>4</b>	<b>CPU Interface</b>	<b>15</b>
4.1	CPU Interface Pin Mapping	15
4.2	CPU Bus Connector Pin Mapping	16
<b>5</b>	<b>LCD Interface Pin Mapping</b>	<b>18</b>
<b>6</b>	<b>Technical Description</b>	<b>19</b>
6.1	PCI Bus Support	19
6.2	Direct Host Bus Interface Support	19
6.3	S1D13705 Embedded Memory	19
6.4	Adjustable LCD Panel Positive Power Supply (VDDH)	19
6.5	Adjustable LCD Panel Negative Power Supply (VLCD)	20
6.6	Passive/Active LCD Panel Support	20
6.7	Power Save Modes	20
6.8	Clock Options	21
<b>7</b>	<b>Software</b>	<b>22</b>
<b>8</b>	<b>References</b>	<b>23</b>
8.1	Documents	23
8.2	Document Sources	23
<b>9</b>	<b>Parts List</b>	<b>24</b>
<b>10</b>	<b>Schematics</b>	<b>26</b>
<b>11</b>	<b>Board Layout</b>	<b>31</b>
<b>12</b>	<b>Technical Support</b>	<b>32</b>
12.1	EPSON LCD Controllers (S1D13705)	32

**THIS PAGE LEFT BLANK**

## List of Tables

Table 3-1: Configuration DIP Switch Settings . . . . .	10
Table 3-2: Jumper Summary . . . . .	11
Table 4-1: CPU Interface Pin Mapping . . . . .	15
Table 4-2: CPU Bus Connector (H1) Pinout . . . . .	16
Table 4-3: CPU Bus Connector (H2) Pinout . . . . .	17
Table 5-1: LCD Signal Connector (J5) . . . . .	18

## List of Figures

Figure 3-1: Configuration DIP Switch (SW1) Location . . . . .	9
Figure 3-2: Configuration Jumper (JP1) Location . . . . .	11
Figure 3-3: Configuration Jumper (JP2) Location . . . . .	12
Figure 3-4: Configuration Jumper (JP3) Location . . . . .	12
Figure 3-5: Configuration Jumper (JP4) Location . . . . .	13
Figure 3-6: Configuration Jumper (JP5) Location . . . . .	13
Figure 3-7: Configuration Jumper (JP6) Location . . . . .	14
Figure 3-8: Configuration Jumper (JP7) Location . . . . .	14
Figure 10-1: S1D13705B00C Schematics (1 of 5) . . . . .	26
Figure 10-2: S1D13705B00C Schematics (2 of 5) . . . . .	27
Figure 10-3: S1D13705B00C Schematics (3 of 5) . . . . .	28
Figure 10-4: S1D13705B00C Schematics (4 of 5) . . . . .	29
Figure 10-5: S1D13705B00C Schematics (5 of 5) . . . . .	30

**THIS PAGE LEFT BLANK**

---

# 1 Introduction

This manual describes the setup and operation of the S5U13705B00C Rev. 2.0 Evaluation Board. The board is designed as an evaluation platform for the S1D13705 Embedded Memory LCD Controller.

This user manual is updated as appropriate. Please check the Epson Research and Development Website at [www.erd.epson.com](http://www.erd.epson.com) for the latest revision of this document before beginning any development.

We appreciate your comments on our documentation. Please contact us via email at [documentation@erd.epson.com](mailto:documentation@erd.epson.com).

## 2 Features

Following are some features of the S5U13705B00C Rev. 2.0 Evaluation Board:

- 80-pin TQFP S1D13705F00A Embedded Memory LCD Controller with 80K bytes of embedded SRAM.
- Headers for connecting to various Host Bus Interfaces.
- Configuration options.
- Adjustable positive LCD bias power supply from +23V to +40V.
- Adjustable negative LCD bias power supply from -23V to -14V.
- 4/8-bit 3.3V or 5V single monochrome or color passive LCD panel support.
- 9/12-bit 3.3V or 5V active matrix TFT LCD panel support.
- Software and hardware initiated power save mode.
- Selectable clock source for bus clock and CLKI.
- External oscillator for CLKI (up to 50MHz with internal clock divider or 25MHz with no internal clock divider) and BUSCLK.



## 3 Installation and Configuration

The S5U13705B00C is designed to support as many platforms as possible. The S5U13705B00C incorporates a DIP switch and seven jumpers which allow both evaluation board and S1D13705 LCD controller to be configured for a specified evaluation platform.

### 3.1 Configuration DIP Switches

The S1D13705 has configuration inputs (CNF[3:0]) and BS# input, which are read on the rising edge of RESET#. In order to configure the S1D13705 for multiple Host Bus Interfaces a six-position DIP switch (SW1) is required. The following figure shows the location of DIP switch SW1 on the S5U13705B00C.

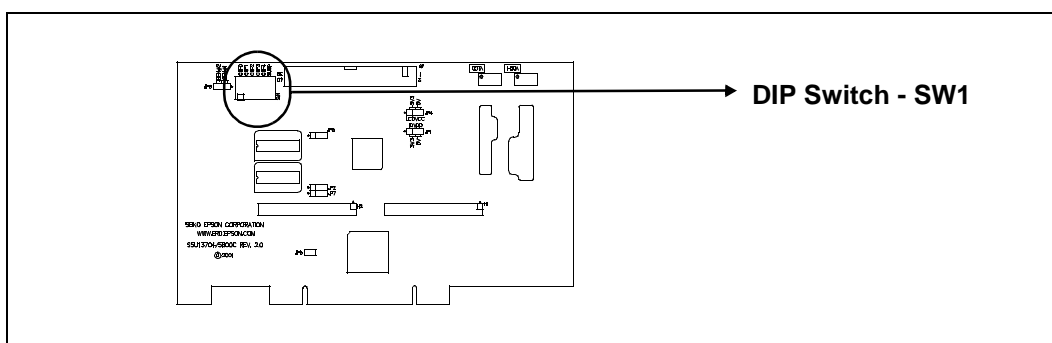



Figure 3-1: Configuration DIP Switch (SW1) Location

The S1D13705 has 4 configuration inputs (CONF[3:0]) and BS# input, which are read on the rising edge of RESET#. All S1D13705 configuration inputs and BS# input are fully configurable using a six position DIP switch as described below and a jumper for BS#.

*Table 3-1: Configuration DIP Switch Settings*

Switch	S1D13705 Signal	Value on this pin at rising edge of RESET# is used to configure:			
		Open (Off/1)			Closed (On/0)
SW1-[3:1]	CNF[2:0]	Select host bus interface as follows:			
		<b>CNF2</b>	<b>CNF1</b>	<b>CNF0</b>	<b>Host Bus Interface</b>
		0	0	0	SH-4
		0	0	1	SH-3
		0	1	0	Reserved
		0	1	1	MC68K #1
		1	0	0	Reserved
		1	0	1	MC68K #2
		1	1	0	Reserved
		1	1	1	Generic #1/Generic #2 <sup>1</sup>
Note: The host bus interface is 16-bit.					
SW1-4	CNF3	Big Endian bus interface			Little Endian bus interface
SW1-5	Not Used	Not Used			
SW1-6	GPIO0	Hardware Suspend Enable			Hardware Suspend Disable

 = Required settings when used with PCI Bridge FPGA

**Note**

<sup>1</sup> The selection between Generic #1 and Generic #2 is made with JP3.

## 3.2 Configuration Jumpers

The S5U13705B00C has six jumper blocks which configure various setting on the board. The jumper positions for each function are shown below.

Table 3-2: Jumper Summary

Jumper	Function	Position 1-2	Position 2-3	No Jumper
JP1	IOVDD Selection	+3.3V IOVDD	+5.0V IOVDD	n/a
JP2	Bus Clock Selection	External Oscillator (U7)	From Host CPU	n/a
JP3	BS# Signal Selection	Pulled Down to GND (for Generic #1 Interface)	Pulled High to IOVDD (for Generic #2 Interface)	For SH-3, SH-4, MC68k #1 and MC68K #2 bus
JP4	LCD Panel Voltage Selection	+3.3V LCDVCC	+5.0V LCDVCC	n/a
JP5	PCI Bridge FPGA	Disabled for non-PCI host	n/a	Enabled for PCI host
JP6	LCDPWR Polarity	Active Low	Active High	n/a
JP7	CLKI Selection	External Oscillator (U2)	BCLK	n/a

 = Required settings when used with PCI Bridge FPGA

### JP1 - IOVDD Selection

JP1 selects the IOVDD voltage for S1D13705.

When the jumper is in position 1-2, IOVDD is 3.3V. This settings must be used for a 3.3V host CPU system.

When the jumper is in position 2-3, IOVDD is 5.0V. This setting must be used for a 5.0V host CPU system.

#### Note

For PCI host, JP1 can be set in either position.

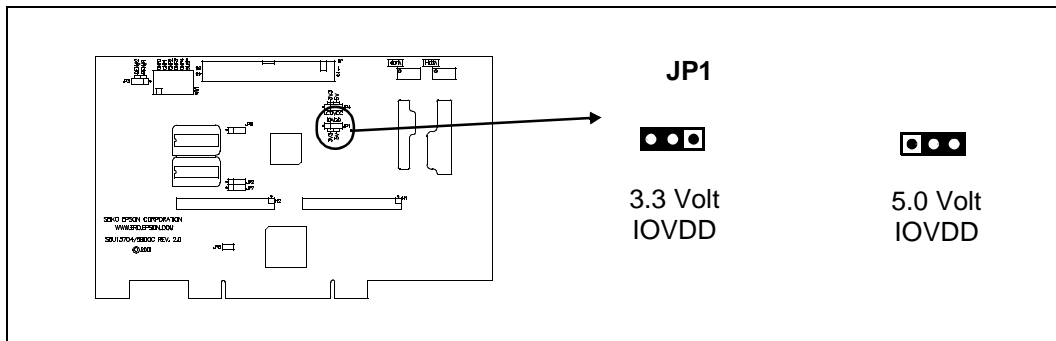

Figure 3-2: Configuration Jumper (JP1) Location

### JP2 - Bus Clock Selection

JP2 selects the source for BCLK input on S1D13705.

When the jumper is in position 1-2, the BCLK source is the external oscillator U7. This position must be used for PCI-host.

When the jumper is in position 2-3, the BCLK must be provided by the host CPU. This setting may be used for non-PCI host.

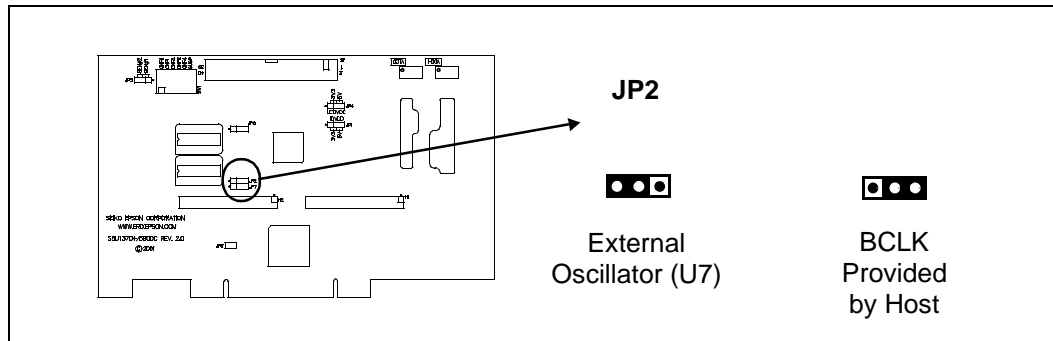

Figure 3-3: Configuration Jumper (JP2) Location

### JP3 - BS# Signal Selection

JP3 is used to pull up or down BS# input of S1D13705 for selection of Generic #1 or Generic #2 interface.

When the jumper is in position 1-2, BS# is pulled down to select Generic #1 interface.

When the jumper is in position 2-3, BS# is pulled high to IOVDD, to select Generic #2 interface.

For SH-3, SH-4, MC68K #1 and MC68K #2 buses, which use BS# line, the jumper should not be installed.

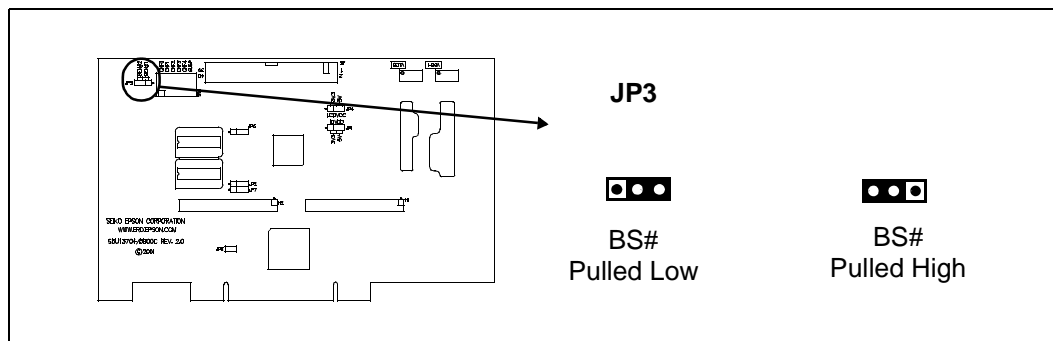

Figure 3-4: Configuration Jumper (JP3) Location

### JP4 - LCD Panel Voltage Selection

JP4 selects voltage level to the LCD panel.

When the jumper is in position 1-2, the voltage level is set to 3.3V.

When the jumper is in position 2-3, the voltage level is set to 5.0V.

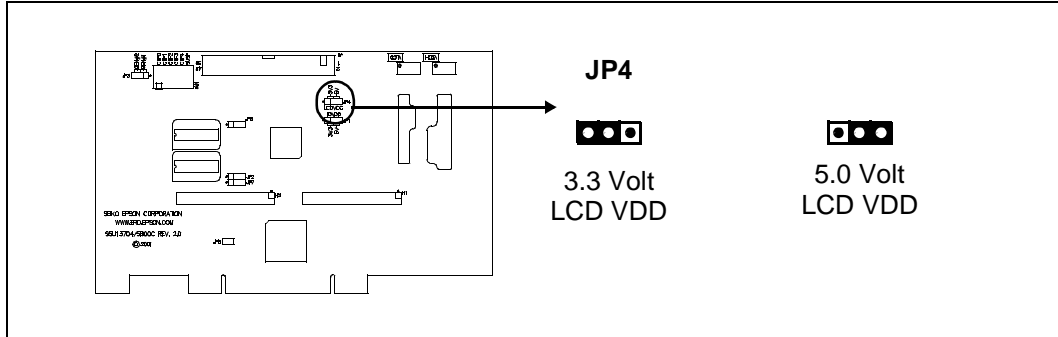

Figure 3-5: Configuration Jumper (JP4) Location

### JP5 - PCI Bridge FPGA

JP5 is used to enable or disable the PCI bridge FPGA.

When the jumper is in position 1-2, the PCI bridge FPGA is disabled. This position must be used for non-PCI host.

When the jumper is off, the PCI bridge FPGA is enabled. The jumper must not be present for PCI host.

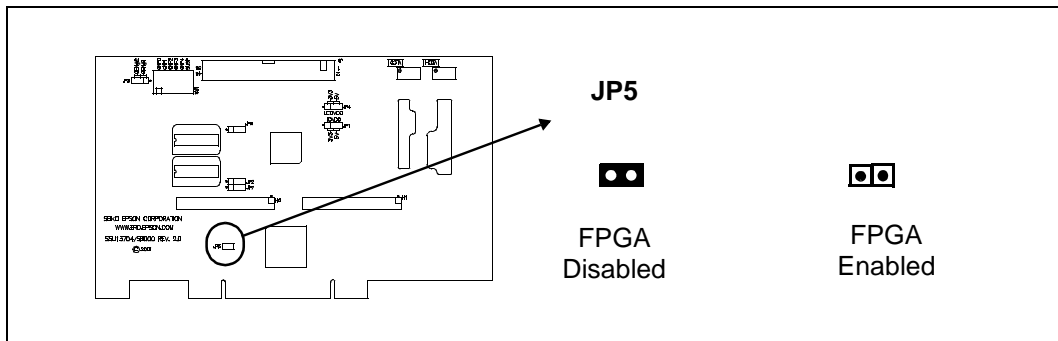

Figure 3-6: Configuration Jumper (JP5) Location

### JP6 - LCDPWR Polarity

LCDPWR output from S1D13705 is only active high but some panels may require an active low signal. To provide both active high and active low signals, the output from S1D13705 is inverted and the selection is made by the setting of JP6

When the jumper is in position 1-2, LCDPWR signal to the panel is active low

When the jumper is in position 2-3, LCDPWR signal to the panel is active high

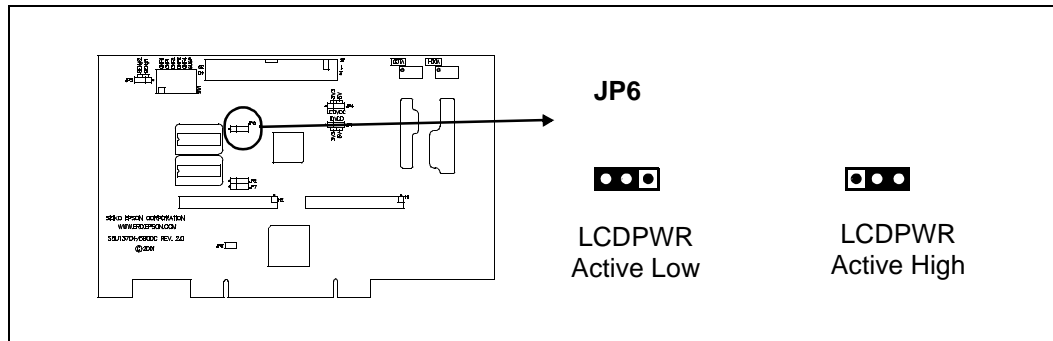

Figure 3-7: Configuration Jumper (JP6) Location

### JP7 - CLKI Selection

JP7 selects the source for CLKI input on S1D13705.

When the jumper is in position 1-2, CLKI signal is provided by external oscillator U2

When the jumper is in position 2-3, CLKI signal is the same as BCLK signal

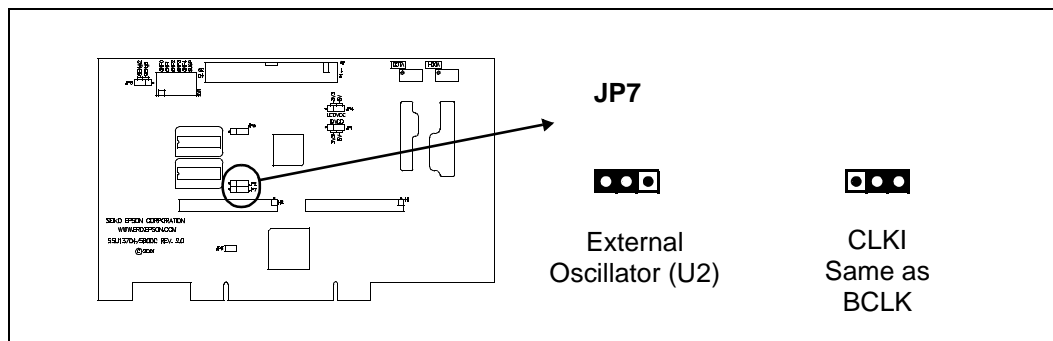

Figure 3-8: Configuration Jumper (JP7) Location

## 4 CPU Interface

### 4.1 CPU Interface Pin Mapping

Table 4-1: CPU Interface Pin Mapping

S1D13705 Pin Name	Generic #1	Generic #2	Hitachi SH-3	Hitachi SH-4	Motorola MC68K #1	Motorola MC68K #2
AB[16:1]	A[16:1]	A[16:1]	A[16:1]	A[16:1]	A[16:1]	A[16:1]
AB0	A0	A0	A0	A0	LDS#	A0
DB[15:0]	D[15:0]	D[15:0]	D[15:0]	D[15:0]	D[15:0]	D[15:0] <sup>1</sup>
CS#	External Decode		CSn#	CSn#	External Decode	
BCLK	BCLK	BCLK	CKIO	CKIO	CLK	CLK
BS#	Connect to VSS	Connect to IOVDD	BS#	BS#	AS#	AS#
RD/WR#	RD1#	Connect to IOVDD	RD/WR#	RD/WR#	R/W#	R/W#
RD#	RD0#	RD#	RD#	RD#	Connect to IOVDD	SIZ1
WE0#	WE0#	WE#	WE0#	WE0#	Connect to IOVDD	SIZ0
WE1#	WE1#	BHE#	WE1#	WE1#	UDS#	DS#
WAIT#	WAIT#	WAIT#	WAIT#	RDY#	DTACK#	DSACK1#
RESET#	RESET#	RESET#	RESET#	RESET#	RESET#	RESET#

**Note**

<sup>1</sup> If the target MC68K bus is 32-bit, then these signals should be connected to D[31:16].

## 4.2 CPU Bus Connector Pin Mapping

Table 4-2: CPU Bus Connector (H1) Pinout

Connector Pin No.	Comments
1	Connected to DB0 of the S1D13705
2	Connected to DB1 of the S1D13705
3	Connected to DB2 of the S1D13705
4	Connected to DB3 of the S1D13705
5	Ground
6	Ground
7	Connected to DB4 of the S1D13705
8	Connected to DB5 of the S1D13705
9	Connected to DB6 of the S1D13705
10	Connected to DB7 of the S1D13705
11	Ground
12	Ground
13	Connected to DB8 of the S1D13705
14	Connected to DB9 of the S1D13705
15	Connected to DB10 of the S1D13705
16	Connected to DB11 of the S1D13705
17	Ground
18	Ground
19	Connected to DB12 of the S1D13705
20	Connected to DB13 of the S1D13705
21	Connected to DB14 of the S1D13705
22	Connected to DB15 of the S1D13705
23	Connected to RESET# of the S1D13705
24	Ground
25	Ground
26	Ground
27	+12 volt supply
28	+12 volt supply
29	Connected to WE0# of the S1D13705
30	Connected to WAIT# of the S1D13705
31	Connected to CS# of the S1D13705
32	Not connected
33	Connected to WE1# of the S1D13705
34	Connected to IOVDD



*Table 4-3: CPU Bus Connector (H2) Pinout*

<b>Connector Pin No.</b>	<b>Comments</b>
1	Connected to AB0 of the S1D13705
2	Connected to AB1 of the S1D13705
3	Connected to AB2 of the S1D13705
4	Connected to AB3 of the S1D13705
5	Connected to AB4 of the S1D13705
6	Connected to AB5 of the S1D13705
7	Connected to AB6 of the S1D13705
8	Connected to AB7 of the S1D13705
9	Ground
10	Ground
11	Connected to AB8 of the S1D13705
12	Connected to AB9 of the S1D13705
13	Connected to AB10 of the S1D13705
14	Connected to AB11 of the S1D13705
15	Connected to AB12 of the S1D13705
16	Connected to AB13 of the S1D13705
17	Ground
18	Ground
19	Connected to AB14 of the S1D13705
20	Connected to AB15 of the S1D13705
21	Connected to AB16 of the S1D13705
22	Not connected
23	Not connected
24	Not connected
25	Ground
26	Ground
27	+5 volt supply
28	+5 volt supply
29	Connected to RD/WR# of the S1D13705
30	Connected to BS# of the S1D13705
31	Connected to BCLK of the S1D13705
32	Connected to RD# of the S1D13705
33	Not connected
34	Not connected

## 5 LCD Interface Pin Mapping

Table 5-1: LCD Signal Connector (J5)

Pin Name	Connector Pin No.	Monochrome Passive			Color Passive Panel				Color TFT Panel	
		Single		Dual	Single			Dual		
		4-bit	8-bit		8-bit	4-bit	Format 1		Format 2	8-bit
BFPDAT0	1	driven 0	D0	LD0	driven 0	D0 (B5) <sup>1</sup>	D0 (G3) <sup>1</sup>	LD0 (IR2) <sup>1</sup>	R2	R3
BFPDAT1	3	driven 0	D1	LD1	driven 0	D1 (R5) <sup>1</sup>	D1 (R3) <sup>1</sup>	LD1 (IB1) <sup>1</sup>	R1	R2
BFPDAT2	5	driven 0	D2	LD2	driven 0	D2 (G4) <sup>1</sup>	D2 (B2) <sup>1</sup>	LD2 (IG1) <sup>1</sup>	R0	R1
BFPDAT3	7	driven 0	D3	LD3	driven 0	D3 (B3) <sup>1</sup>	D3 (G2) <sup>1</sup>	LD3 (IR1) <sup>1</sup>	G2	G3
BFPDAT4	9	D0	D4	UD0	D0 (R2) <sup>1</sup>	D4 (R3) <sup>1</sup>	D4 (R2) <sup>1</sup>	UD0 (uR2) <sup>1</sup>	G1	G2
BFPDAT5	11	D1	D5	UD1	D1 (B1) <sup>1</sup>	D5 (G2) <sup>1</sup>	D5 (B1) <sup>1</sup>	UD1 (uB1) <sup>1</sup>	G0	G1
BFPDAT6	13	D2	D6	UD2	D2 (G1) <sup>1</sup>	D6 (B1) <sup>1</sup>	D6 (G1) <sup>1</sup>	UD2 (uG1) <sup>1</sup>	B2	B3
BFPDAT7	15	D3	D7	UD3	D3 (R1) <sup>1</sup>	D7 (R1) <sup>1</sup>	D7 (R1) <sup>1</sup>	UD3 (uR1) <sup>1</sup>	B1	B2
BFPDAT8	17	GPIO1							B0	B1
BFPDAT9	19	GPIO2							R0	
BFPDAT10	21	GPIO3							G0	
BFPDAT11	23	GPIO4							B0	
BFPSHIFT	33	FPSHIFT								
BDRDY	35 & 38	MOD				FPSHIFT2	MOD		DRDY	
BFPLINE	37	FPLINE								
BFPFRAME	39	FPFRAME								
GND	2-26 (Even Pins)	GND								
VLCD	30	Adjustable -24V to -14V negative LCD bias								
LCDVCC	32	LCDVCC (3.3V / 5.0V)								
+12V	34	+12V								
VDDH	36	Adjustable +23V to +40V positive LCD bias								
BLCDPWR	40	LCDPWR <sup>2</sup> (for controlling on-board LCD bias power supply on/off)								

### Note

<sup>1</sup>These pin mappings use signal names commonly used for each panel type, however signal names may differ between panel manufacturers. The values shown in brackets represent the color components as mapped to the corresponding FPDATxx signals at the first valid edge of FPSHIFT. For further FPDATxx to LCD interface mapping, see *S1D13705 Hardware Functional Specification*, document number **X27A-A-001-xx**.

<sup>2</sup>LCDPWR on J5 can be inverted by setting JP6 to 1-2.

## 6 Technical Description

### 6.1 PCI Bus Support

The S1D13705 **does not** have on-chip PCI bus interface support. The S1D13705B00C uses the PCI Bridge FPGA to support the PCI bus. When using the PCI Bridge FPGA, a Windows device driver is required, see Section 7, “Software” on page 22 for further information on available software and drivers.

### 6.2 Direct Host Bus Interface Support

The S5U13705B00C is specifically designed to work using the PCI Bridge FPGA in a standard PCI bus environment. However, the S1D13705 directly supports many other host bus interfaces. Connectors H1 and H2 provide the necessary IO pins to interface to these host buses. For further information on the host bus interfaces supported, see “CPU Interface” on page 15.

**Note**

The PCI Bridge FPGA must be disabled using JP5 in order for direct host bus interface to operate properly.

### 6.3 S1D13705 Embedded Memory

The S1D13705 has 80K bytes of embedded SRAM. The 80K byte display buffer address space is directly and contiguously available through the 17-bit address bus.

The S1D13705 registers are located in the upper 32 bytes of the 128K byte address range of S1D13705.

### 6.4 Adjustable LCD Panel Positive Power Supply (VDDH)

For those LCD panels requiring a positive power supply to provide between +23V and +40V ( $I_{out} = 45\text{mA}$ ) a power supply has been provided as an integral part of this design. The VDDH power supply can be adjusted by R15 to provide an output voltage from +23V to +40V and is enabled and disabled by the active high LCDPWR control signal of S1D13705 and inverted externally.

Determine the panel’s specific power requirements and set the potentiometer accordingly before connecting the panel.

## 6.5 Adjustable LCD Panel Negative Power Supply (VLCD)

For those LCD panels requiring a negative power supply to provide between -23V and -14V ( $I_{out} = 25\text{mA}$ ) a power supply has been provided as an integral part of this design. The VLCD power supply can be adjusted by R21 to give an output voltage from -23V to -14V and is enabled and disabled by the active high LCDPWR control signal of S1D13705 and inverted externally.

Determine the panel's specific power requirements and set the potentiometer accordingly before connecting the panel.

## 6.6 Passive/Active LCD Panel Support

The S1D13705 directly supports:

- 4/8-bit, single and dual, monochrome passive panels.
- 4/8-bit, single and dual, color passive panels.
- 9/12-bit, TFT active matrix panels.

All the necessary signals are provided on the 40-pin LCD connector J5. For connection information, refer to **Table 5-1: "LCD Signal Connector (J5)"** on page 18.

The buffered LCD connector (J5) provides the same LCD panel signals as those directly from S1D13705, but with voltage-adapting buffers selectable to 3.3V or 5.0V. Pin 32 on this connector provides a voltage level of 3.3V or 5.0V to the LCD panel logic (see "JP6 - LCDPWR Polarity" on page 14 for information on setting the panel voltage).

## 6.7 Power Save Modes

The S1D13705 supports one hardware and one software power save mode. The hardware power save mode needs to be enabled by setting REG[02h] bit1 to 1 and then can be activated by DIP switch SW1-6. See **Table 3-1: "Configuration DIP Switch Settings"** on page 10.

## 6.8 Clock Options

The input clock (CLKI) frequency can be up to 50MHz for the S1D13705 if the internal divide-by-2 mode is set. If the clock divider is not used, the maximum CLKI frequency is 25MHz. There is no minimum input clock frequency.

A 6.0MHz oscillator (U2, socketed) is provided as the input clock source. However, depending on the LCD resolution, desired frame rate and power consumption budget, another clock frequency may be required.

A jumper, JP7 is provided to allow CLKI input to be the same as BCLK input, for systems in which is desired to use only one clock signal for both BCLK and CLKI.

The bus clock (BCLK) is selectable and can be provided by a 50MHz oscillator (U7, socketed) or the host CPU (for non-PCI host).

## 7 Software

This evaluation board, when used with the PCI Bridge FPGA adapter, requires drivers to work in the 32-bit Windows environment. See the *S1D13XXX 32-Bit Windows Device Driver Installation Guide*, document number X00A-E-003-xx for more information.

Test utilities and display drivers are also available for the S1D13705. Full source code is available for both the test utilities and the drivers.

The test utilities are configurable for different panel types using a program called 13705CFG, or by directly modifying the source. The display drivers can be customized by the OEM for different panel types, resolutions and color depths only by modifying the source.

The S1D13705 test utilities and drivers are available from your sales support contact or on the internet at [www.erd.epson.com](http://www.erd.epson.com).

---

## 8 References

### 8.1 Documents

- Epson Research and Development, Inc., *S1D13705 Hardware Functional Specification*, document number **X27A-A-001-xx**.
- Epson Research and Development, Inc., *S1D13705 Programming Notes and Examples*, document number **X27A-G-002-xx**.
- Epson Research and Development, Inc., *S1D13XXX 32-Bit Windows Device Driver Installation Guide*, document number **X00A-E-003-xx**.

### 8.2 Document Sources

- Epson Research and Development Website: <http://www.erd.epson.com>.

## 9 Parts List

Item	Quantity	Reference	Part	Description
1	15	C1-C11, C16, C17, C24, C25	0.1uF, 20%, 50V	1206 pckg., ceramic capacitor
2	1	C12	10uF, 10%, 25V	Tantalum capacitor size D
3	2	C22,C18	47uF, 10%, 16V	Tantalum capacitor size D
4	3	C19,C20,C21	4.7uF, 10%, 50V	Tantalum capacitor size D
5	1	C23	56uF, 20%, 35V, Low ESR	Electrolytic, radial, low ESR
6	2	C36,C33	33uF, 10%, 20V	Tantalum capacitor size D
7	3	C34,C35,C37	68uF, 10%, 10V	Tantalum capacitor size D
8	9	C38-C46	0.22uF, 5%, 50V	X7R, 1206 pckg
9	2	H2,H1	HEADER 17X2	0.1", 17x2, unshrouded header
10	6	JP1,JP2,JP3,JP4,JP6,JP7	HEADER 3	0.1", 3x1, unshrouded header
11	1	JP5	HEADER 2	0.1", 2x1, unshrouded header
12	1	J5	CON40A	0.1", 20x2, 0.025" sq. shrouded header, center key, t/h
13	1	L1	1uH	RCD MCI-1812 inductor 1uH MT or MSI-1812 1uH MT
14	3	L2,L3,L4	Ferrite Bead	Philips BDS3/3/8.9-4S2
15	1	Q1	MMBT3906	Generic MMBT3906
16	1	Q2	MMBT3904	Generic MMBT3904
17	13	R1-R6, R10, R11, R33, R36-R39	15K, 5%	1206 resistor
18	1	R8	0R	1206 resistor, 0 ohms
19	1	R14	475K, 1%	1206 resistor
20	1	R15	200K Pot.	200K Trim POT Spectrol 63S204T607 or equiv.
21	1	R16	14K, 1%	1206 resistor
22	2	R18, R17	10K, 5%	1206 resistor
23	3	R19, R20, R32	100K, 5%	1206 resistor
24	1	R21	100K Pot.	100K Trim POT Spectrol 63S104T607 or equiv.
25	3	R34, R35, R40	1K, 5%	1206 resistor
26	1	SW1	SW DIP-6	6 position DIP switch
27	1	U1	S1D13705	
28	1	U2	14-pin DIP socket	Machined socket, 14-pin
29	1	U2	6MHz	Fox 6.0MHz oscillator or equiv., 14-pin DIP pckg, socketed
30	3	U3,U4,U5	74AHC244	SO-22, TI74AHC244 or equivalent
31	1	U6	LT1117CM-3.3	Linear Technology 5V to 3.3V regulator, 800mA or equiv.



Item	Quantity	Reference	Part	Description
32	1	U7	14-pin DIP socket	Machined socket, 14-pin
33	1	U7	50MHz	Fox 50.0MHz oscillator or equiv., 14-pin DIP pckg, socketed
34	1	U8	74AHC04/SO	SO-14, 74AHC04
35	1	U9	74HCT86/SO	SO-14, 74HCT86
36	1	U10	RD-0412	Xentek RD-0412, positive power supply
37	1	U11	EPN001	Xentek EPN001, negative power supply
38	1	U14	EPF6016TC144-2	Altera EPF6016TC144-2
39	1	U15	8-pin DIP socket	Machined socket, 8-pin
40	1	U15	EPC1441PC8	Altera EPC1441PC8, socketed
41	6	JP1,JP2,JP3,JP4,JP6,JP7	Jumper shunt for 0.1" header	
42	1		Bracket	Computer Bracket, Blank - PCI, Keystone - Cat. No. 9203
43	2		Scew	Pan Head, #4-40 x 1/4"

# 10 Schematics

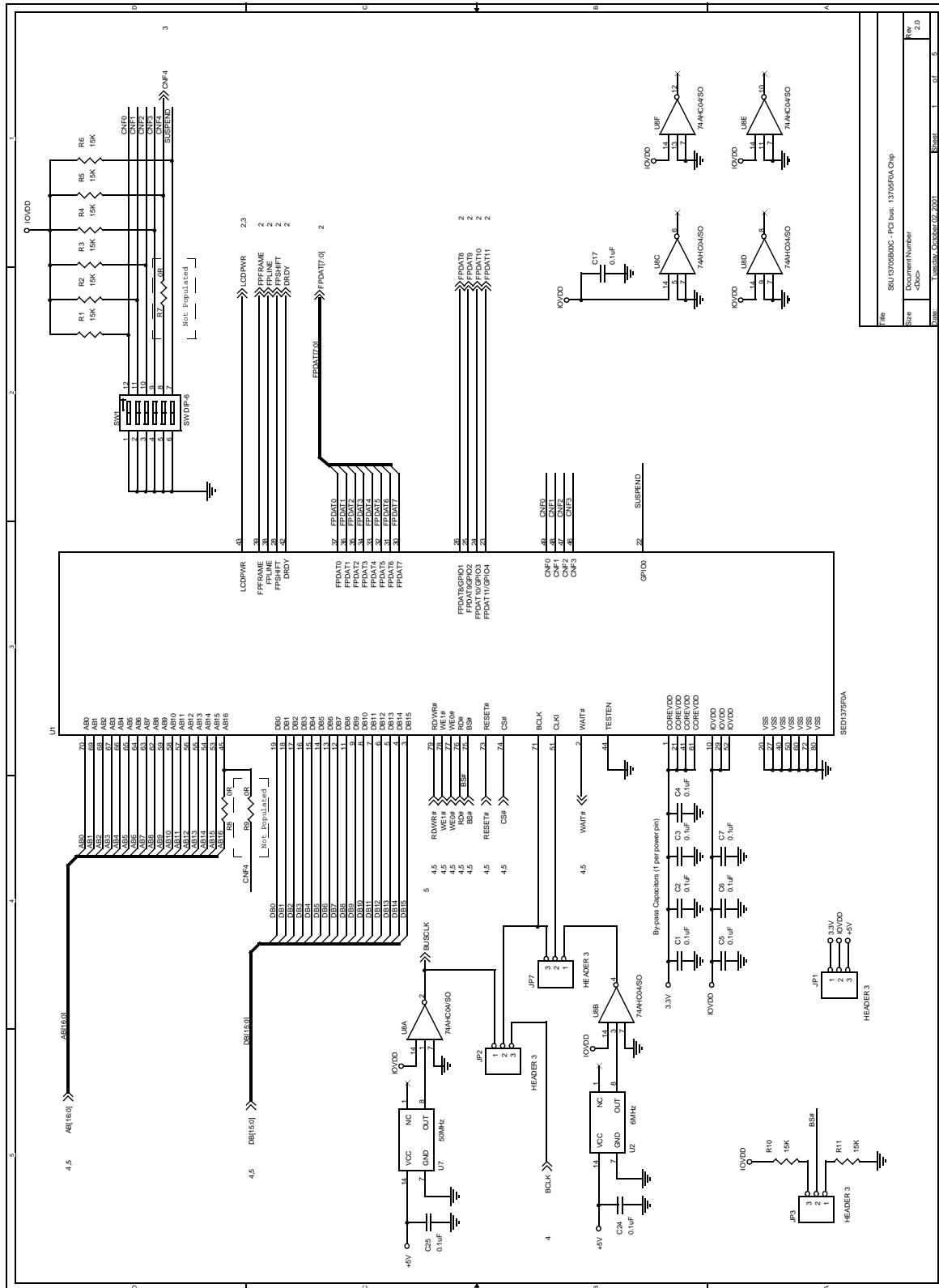

Figure 10-1: S1D13705B00C Schematics (1 of 5)

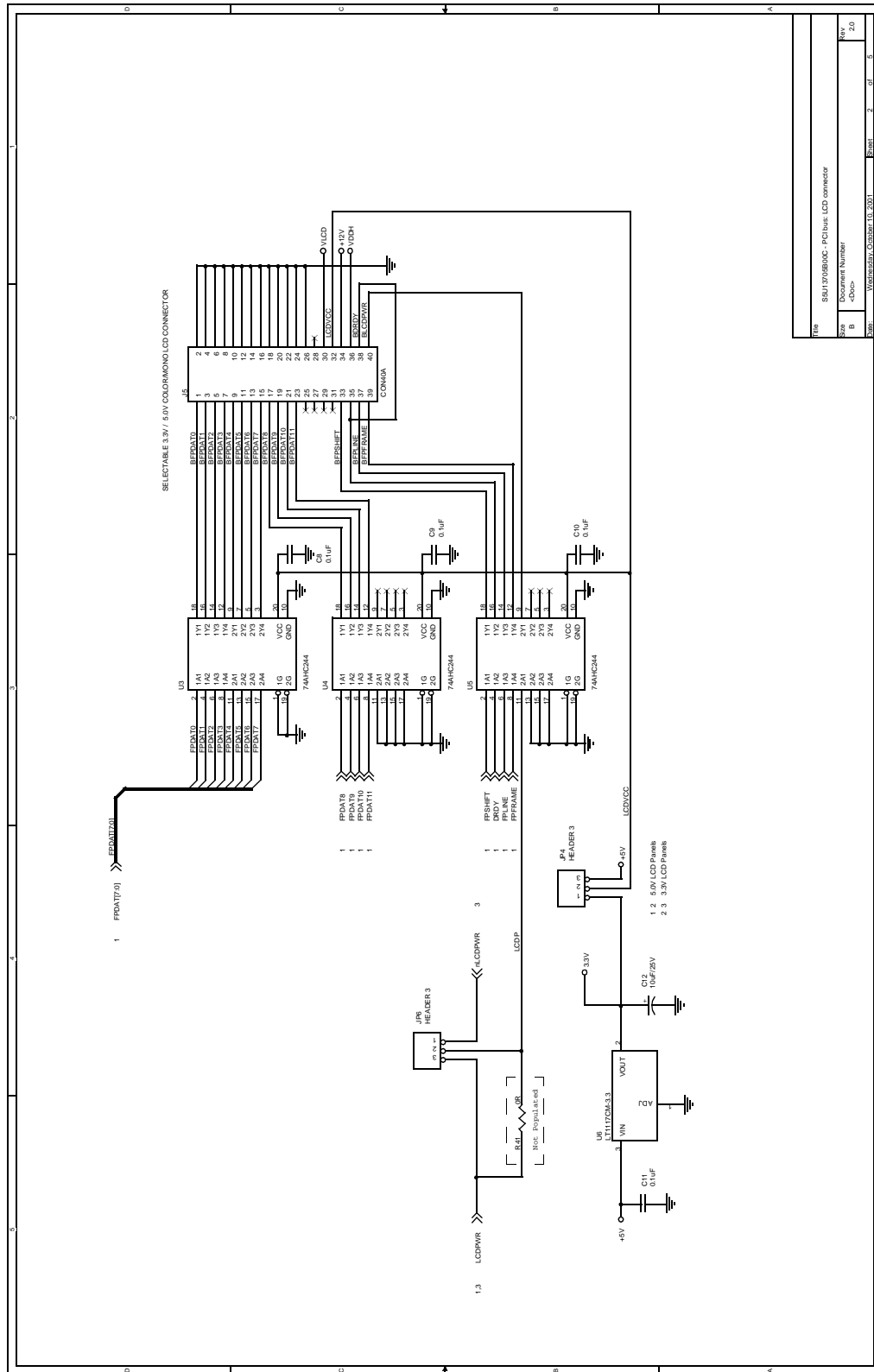

Figure 10-2: S1D13705B00C Schematics (2 of 5)

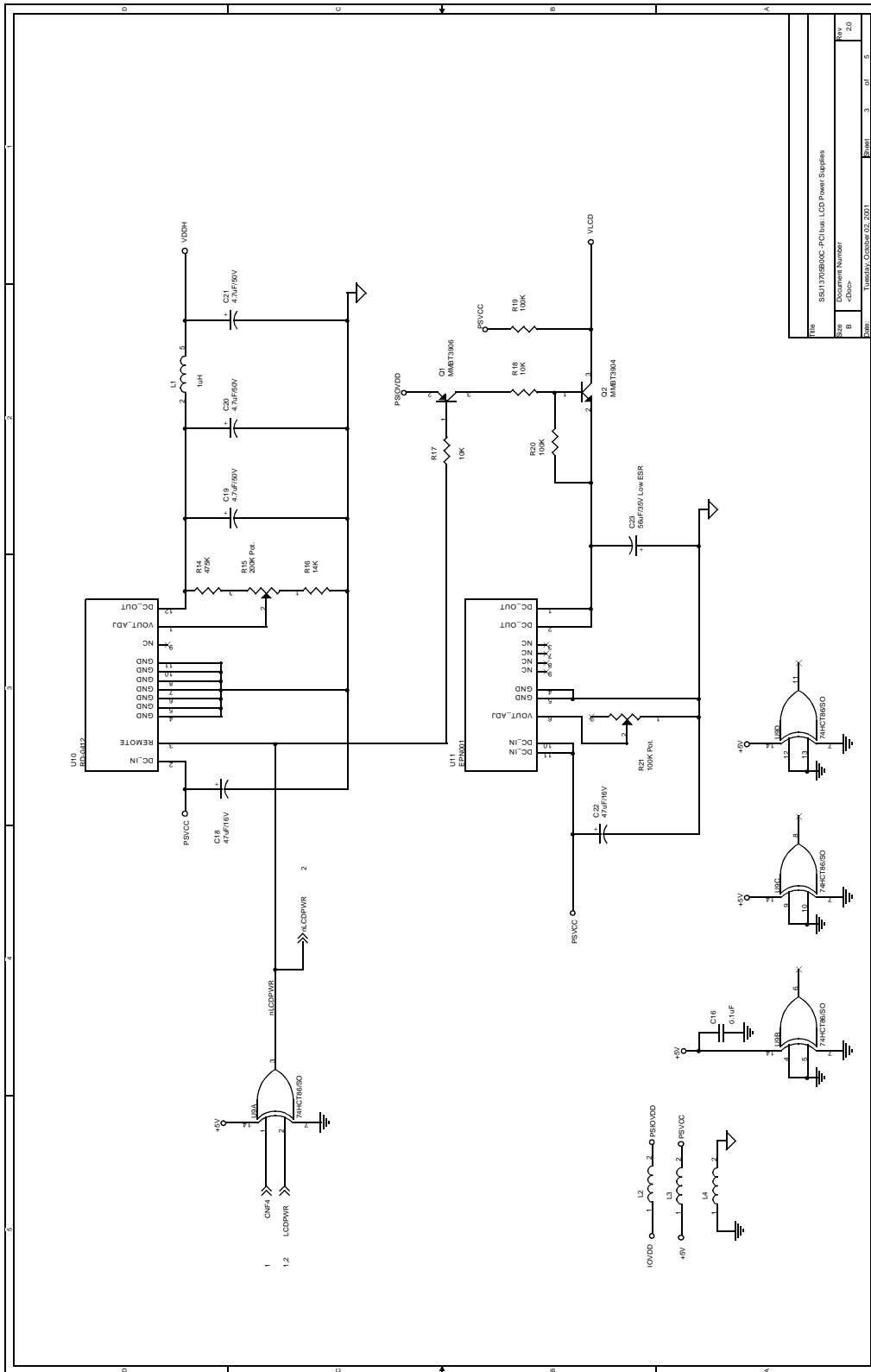

Figure 10-3: S1D13705B00C Schematics (3 of 5)

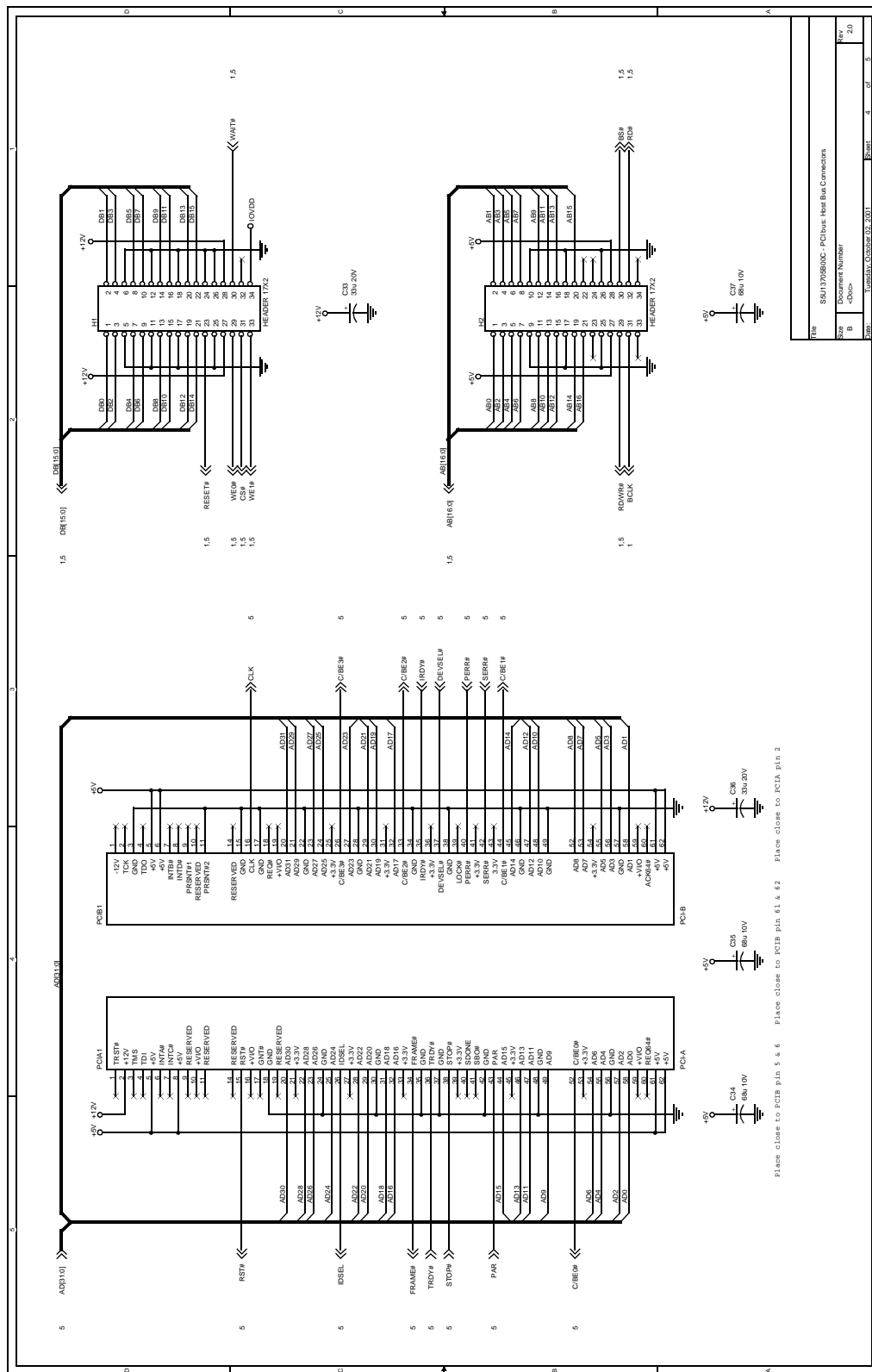

Figure 10-4: S1D13705B00C Schematics (4 of 5)

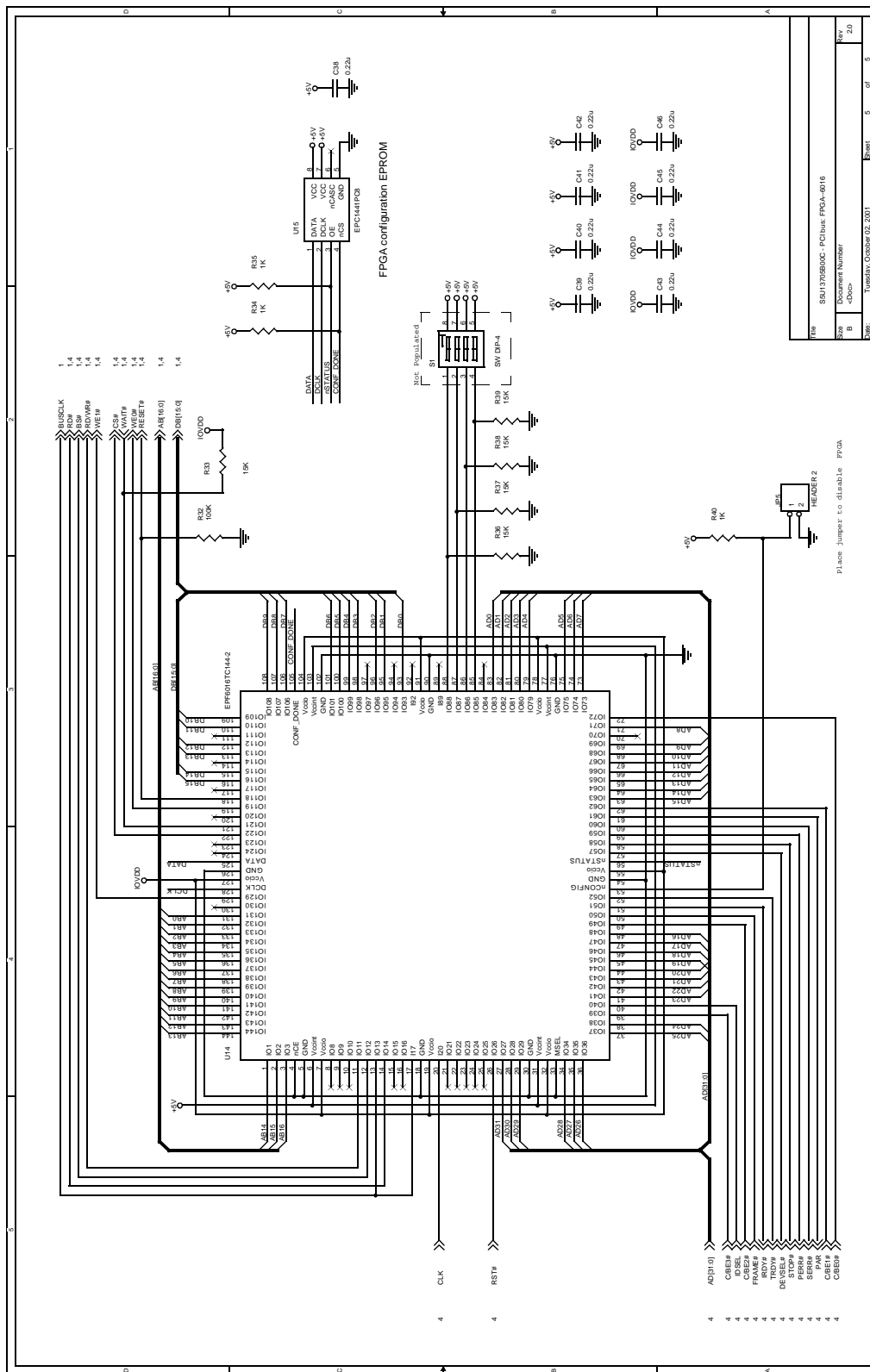
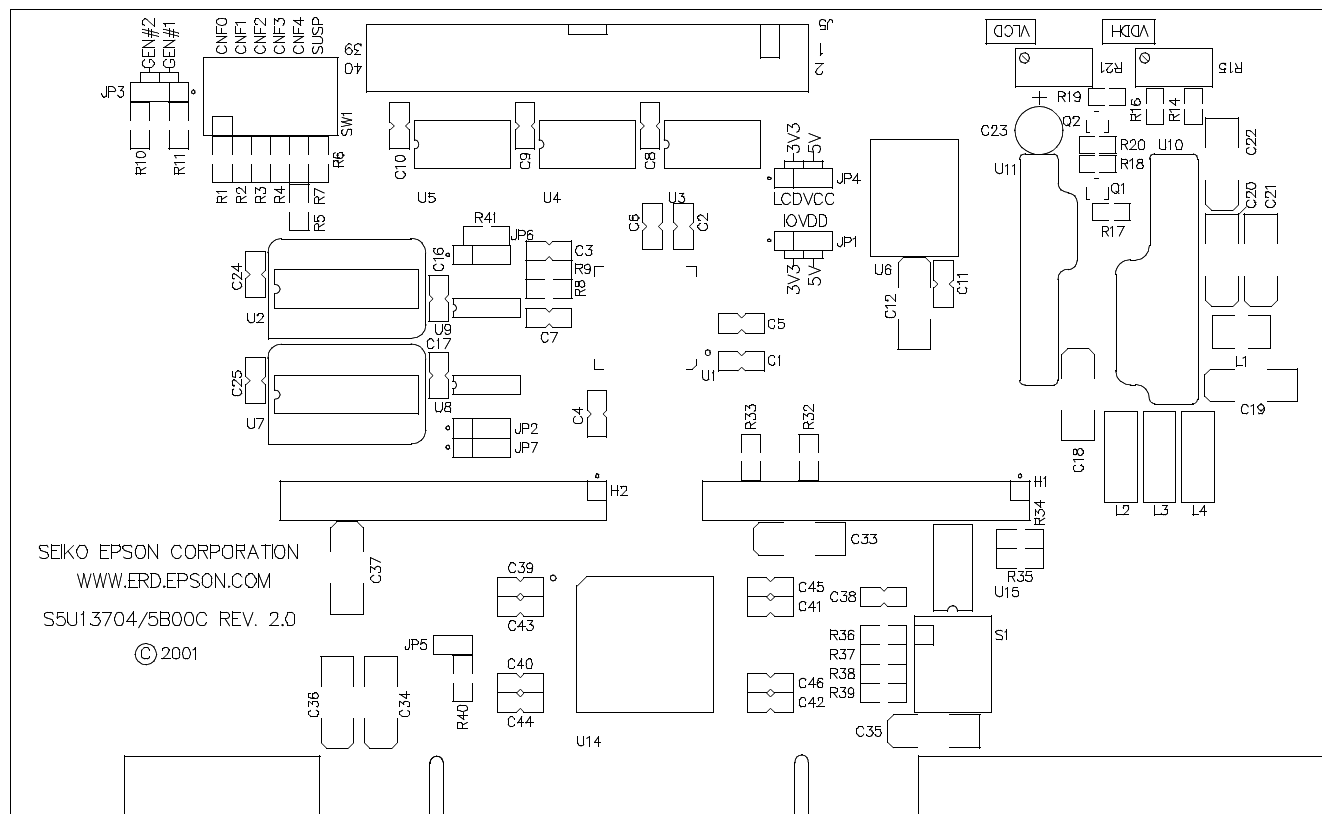

Figure 10-5: S1D13705B00C Schematics (5 of 5)

# 11 Board Layout



# 12 Technical Support

## 12.1 EPSON LCD Controllers (S1D13705)

### Japan

Seiko Epson Corporation  
Electronic Devices Marketing Division  
421-8, Hino, Hino-shi  
Tokyo 191-8501, Japan  
Tel: 042-587-5812  
Fax: 042-587-5564  
<http://www.epson.co.jp/>

### Hong Kong

Epson Hong Kong Ltd.  
20/F., Harbour Centre  
25 Harbour Road  
Wanchai, Hong Kong  
Tel: 2585-4600  
Fax: 2827-4346  
<http://www.epson.com.hk/>

### North America

Epson Electronics America, Inc.  
150 River Oaks Parkway  
San Jose, CA 95134, USA  
Tel: (408) 922-0200  
Fax: (408) 922-0238  
<http://www.eea.epson.com/>

### Europe

Epson Europe Electronics GmbH  
Riesstrasse 15  
80992 Munich, Germany  
Tel: 089-14005-0  
Fax: 089-14005-110  
<http://www.epson-electronics.de/>

### Taiwan

Epson Taiwan Technology  
& Trading Ltd.  
10F, No. 287  
Nanking East Road  
Sec. 3, Taipei, Taiwan  
Tel: 02-2717-7360  
Fax: 02-2712-9164  
<http://www.epson.com.tw/>

### Singapore

Epson Singapore Pte., Ltd.  
No. 1  
Temasek Avenue #36-00  
Millenia Tower  
Singapore, 039192  
Tel: 337-7911  
Fax: 334-2716  
<http://www.epson.com.sg/>



# EPSON®



## S1D13705 Embedded Memory LCD Controller

# Windows® CE 3.x Display Drivers

Document Number: X27A-E-006-01

Copyright © 2001 Epson Research and Development, Inc. All Rights Reserved.

Information in this document is subject to change without notice. You may download and use this document, but only for your own use in evaluating Seiko Epson/EPSON products. You may not modify the document. Epson Research and Development, Inc. disclaims any representation that the contents of this document are accurate or current. The Programs/Technologies described in this document may contain material protected under U.S. and/or International Patent laws.

EPSON is a registered trademark of Seiko Epson Corporation. Microsoft and Windows are registered trademarks of Microsoft Corporation. All other trademarks are the property of their respective owners.

---

**THIS PAGE LEFT BLANK**

---

## WINDOWS® CE 3.x DISPLAY DRIVERS

The Windows CE 3.x display driver is designed to support the S1D13705 Embedded Memory LCD Controller running the Microsoft Windows CE operating system, version 3.0. The driver is capable of: 4 and 8 bit-per-pixel landscape modes (no rotation), and 4 and 8 bit-per-pixel SwivelView™ 270 degree mode.

This document and the source code for the Windows CE drivers are updated as appropriate. Before beginning any development, please check the Epson Electronics America Website at [www.eea.epson.com](http://www.eea.epson.com) or the Epson Research and Development Website at [www.erd.epson.com](http://www.erd.epson.com) for the latest revisions.

We appreciate your comments on our documentation. Please contact us via email at [techpubs@erd.epson.com](mailto:techpubs@erd.epson.com).

## Example Driver Builds

The following sections describe how to build the Windows CE display driver for:

1. Windows CE Platform Builder 3.00 using the GUI interface.
2. Windows CE Platform Builder 3.00 using the command-line interface.

In all examples “x:” refers to the drive letter where Platform Builder is installed.

### Build for CEPC (X86) on Windows CE Platform Builder 3.00 using the GUI Interface

1. Install Microsoft Windows 2000 Professional, or Windows NT Workstation version 4.0 with Service Pack 5 or later.
2. Install Windows CE Platform Builder 3.00.
3. Start Platform Builder by double-clicking on the Microsoft Windows CE Platform Builder icon.
4. Create a new project.
  - a. Select File | New.
  - b. In the dialog box, select the Platforms tab.
  - c. In the platforms dialog box, select “WCE Platform”, set a location for the project (such as x:\myproject), set the platform name (such as myplatform), and set the Processors to “Win32 (WCE x86)”.
  - d. Click the OK button.
  - e. In the dialog box “WCE Platform - Step 1 of 2”, select CEPC.
  - f. Click the Next button.
  - g. In the dialog box “WCE Platform - Step 2 of 2”, select Minimal OS (MinKern).
  - h. Click the Finish button.
  - i. In the dialog box “New Platform Information”, click the OK button.
5. Set the active configuration to “Win32 (WCE x86) Release”.
  - a. From the Build menu, select “Set Active Configuration”.
  - b. Select “MYPLATFORM - Win32 (WCE x86) Release”.
  - c. Click the OK button.
6. Add the environment variable CEPC\_DDI\_S1D13X0X.
  - a. From the Platform menu, select “Settings”.
  - b. Select the “Environment” tab.
  - c. In the Variable box, type “CEPC\_DDI\_S1D13X0X”.

- d. In the Value box, type “1”.
  - e. Click the Set button.
  - f. Click the OK button.
7. Create a new directory S1D13705, under x:\wince300\platform\cepc\drivers\display, and copy the S1D13705 driver source code into this new directory.
  8. Add the S1D13705 driver component.
    - a. From the Platform menu, select “Insert | User Component”.
    - b. Set “Files of type:” to “All Files (\*.\*)”.
    - c. Select the file x:\wince300\platform\cepc\drivers\display\S1D13705\sources.
    - d. In the “User Component Target File” dialog box, select browse and then select the path and the file name of “sources”.
  9. Delete the component “ddi\_flat”.
    - a. In the Workspace window, select the ComponentView tab.
    - b. Show the tree for MYPLATFORM components by clicking on the ‘+’ sign at the root of the tree.
    - c. Right-click on the ddi\_flat component.
    - d. Select “Delete”.
    - e. From the File menu, select “Save Workspace”.
  10. From the Workspace window, click on ParameterView Tab. Show the tree for MY-PLATFORM Parameters by clicking on the ‘+’ sign at the root of the tree. Expand the the WINCE300 tree and then click on “Hardware Specific Files” and then double click on “PLATFORM.BIB”. Edit the file the PLATFORM.BIB file and make the following two changes:

- a. Insert the following text after the line “IF ODO\_NODISPLAY !”:

```
IF CEPC_DDI_S1D13X0X
    ddi.dll  $_FLATRELEASEDIR)\S1D13X0X.dll NK SH
ENDIF
```

- b. Find the section shown below, and insert the lines as marked:

```
IF CEPC_DDI_FLAT !
IF CEPC_DDI_S1D13X0X!           ;Insert this line
IF CEPC_DDI_S3VIRGE !
IF CEPC_DDI_CT655X !
IF CEPC_DDI_VGA8BPP !
IF CEPC_DDI_S3TRIO64 !
IF CEPC_DDI_ATI !
```

```
ddi.dll $( _FLATRELEASEDIR)\ddi_flat.dll NK SH
ENDIF
ENDIF
ENDIF
ENDIF
ENDIF
ENDIF
ENDIF ;Insert this line
ENDIF
```

## 11. Modify MODE0.H.

The file MODE0.H (located in x:\wince300\platform\cepc\drivers\display\S1D13705) contains the register values required to set the screen resolution, color depth (bpp), display type, display rotation, etc.

Before building the display driver, refer to the descriptions in the file MODE0.H for the default settings of the console driver. If the default does not match the configuration you are building for then MODE0.H will have to be regenerated with the correct information.

Use the program 13705CFG to generate the header file. For information on how to use 13705CFG, refer to the *13705CFG Configuration Program User Manual*, document number X27A-B-001-xx, available at [www.erd.epson.com](http://www.erd.epson.com)

After selecting the desired configuration, export the file as a “C Header File for S1D13705 WinCE Drivers”. Save the new configuration as MODE0.H in the \wince300\platform\cepc\drivers\display, replacing the original configuration file.

- From the Platform window, click on ParameterView Tab. Show the tree for MY-PLATFORM Parameters by clicking on the ‘+’ sign at the root of the tree. Expand the the WINCE300 tree and click on “Hardware Specific Files”, then double click on “PLATFORM.REG”. Edit the file PLATFORM.REG to match the screen resolution, color depth, and rotation information in MODE.H.

For example, the display driver section of PLATFORM.REG should be as follows when using a 320x240 LCD panel with a color depth of 8 bpp and a SwivelView mode of 0° (landscape):

```
; Default for EPSON Display Driver
; 320x240 at 8 bits/pixel, LCD display, no rotation
; Useful Hex Values
; 1024=0x400, 768=0x300 640=0x280 480=0x1E0 320=140 240=0xF0
[HKEY_LOCAL_MACHINE\Drivers\Display\S1D13705]
“Width”=dword:140
“Height”=dword:F0
“Bpp”=dword:8
```

“ActiveDisp”=dword:1

“Rotation”=dword:0

13. From the Build menu, select “Rebuild Platform” to generate a Windows CE image file (NK.BIN) in the project directory x:\myproject\myplatform\reldir\x86\_release\nk.bin.

### Build for CEPC (X86) on Windows CE Platform Builder 3.00 using the Command-Line Interface

1. Install Microsoft Windows 2000 Professional, or Windows NT Workstation version 4.0 with Service Pack 5 or later.
2. Install Windows CE Platform Builder 3.00.
3. Create a batch file called x:\wince300\cepath.bat. Put the following in cepath.bat:  
x:  
cd \wince300\public\common\oak\misc  
call wince x86 i486 CE MINSHELL CEPC  
set IMGNODEBUGGER=1  
set WINCEREL=1  
set CEPC\_DDI\_S1D13X0X=1
4. Generate the build environment by calling cepath.bat.
5. Create a new folder called S1D13705 under x:\wince300\platform\cepc\drivers\display, and copy the S1D13705 driver source code into x:\wince300\platform\cepc\drivers\display\S1D13705.
6. Edit the file x:\wince300\platform\cepc\drivers\display\dirs and add S1D13705 into the list of directories.
7. Edit the file x:\wince300\platform\cepc\files\platform.bib and make the following two changes:

- a. Insert the following text after the line “IF ODO\_NODISPLAY !”:

```
IF CEPC_DDI_S1D13X0X
    ddi.dll  $(_FLATRELEASEDIR)\S1D13X0X.dll NK SH
ENDIF
```

- b. Find the section shown below, and insert the lines as marked:

```
IF CEPC_DDI_FLAT !
IF CEPC_DDI_S1D13X0X!           ;Insert this line
IF CEPC_DDI_S3VIRGE !
IF CEPC_DDI_CT655X !
IF CEPC_DDI_VGA8BPP !
IF CEPC_DDI_S3TRIO64 !
IF CEPC_DDI_ATI !
    ddi.dll  $(_FLATRELEASEDIR)\ddi_flat.dll  NK SH
```

```

ENDIF
ENDIF
ENDIF
ENDIF
ENDIF
ENDIF
ENDIF
ENDIF
ENDIF
ENDIF
ENDIF

```

#### 8. Modify MODE0.H.

The file MODE0.H (located in `x:\wince300\platform\cepc\drivers\display\S1D13705`) contains the register values required to set the screen resolution, color depth (bpp), display type, display rotation, etc.

Before building the display driver, refer to the descriptions in the file MODE0.H for the default settings of the display driver. If the default does not match the configuration you are building for then MODE0.H will have to be regenerated with the correct information.

Use the program 13705CFG to generate the header file. For information on how to use 13705CFG, refer to the *13705CFG Configuration Program User Manual*, document number X27A-B-001-xx, available at [www.erd.epson.com](http://www.erd.epson.com)

After selecting the desired configuration, export the file as a “C Header File for S1D13705 WinCE Drivers”. Save the new configuration as MODE0.H in the `\wince300\platform\cepc\drivers\display`, replacing the original configuration file.

#### 9. Edit the file PLATFORM.REG to match the screen resolution, color depth, and rotation information in MODE.H. PLATFORM.REG is located in `x:\wince300\platform\cepc\files`.

For example, the display driver section of PLATFORM.REG should be as follows when using a 320x240 LCD panel with a color depth of 8 bpp and a SwivelView mode of 0° (landscape):

```

; Default for EPSON Display Driver
; 320x240 at 8 bits/pixel, LCD display, no rotation
; Useful Hex Values
; 1024=0x400, 768=0x300 640=0x280 480=0x1E0 320=140 240=0xF0
[HKEY_LOCAL_MACHINE\Drivers\Display\S1D13705]
“Width”=dword:140
“Height”=dword:F0
“Bpp”=dword:8
“ActiveDisp”=dword:1
“Rotation”=dword:0

```



10. Delete all the files in the x:\wince300\release directory and delete the file  
x:\wince300\platform\cepc\\*.bif
11. Type BLDDEMO <ENTER> at the command prompt to generate a Windows CE image  
file. The file generated will be x:\wince300\release\nk.bin.

## Installation for CEPC Environment

Once the NK.BIN file is built, the CEPC environment can be started by booting either from a floppy or hard drive configured with a Windows 9x operating system. The two methods are described below.

1. To start CEPC after booting from a floppy drive:

- a. Create a bootable floppy disk.
- b. Edit CONFIG.SYS on the floppy disk to contain only the following line:

```
device=a:\himem.sys
```

- c. Edit AUTOEXEC.BAT on the floppy disk to contain the following lines:

```
mode com1:9600,n,8,1  
loadcepc /B:9600 /C:1 c:\nk.bin
```

- d. Copy LOADCEPC.EXE and HIMEM.SYS to the bootable floppy disk. Search for the loadCEPC utility in your Windows CE directories.
- e. Copy NK.BIN to c:\.
- f. Boot the system from the bootable floppy disk.

2. To start CEPC after booting from a hard drive:

- a. Copy LOADCEPC.EXE to C:\. Search for the loadCEPC utility in your Windows CE directories.
- b. Edit CONFIG.SYS on the hard drive to contain only the following line:

```
device=c:\himem.sys
```

- c. Edit AUTOEXEC.BAT on the hard drive to contain the following lines:

```
mode com1:9600,n,8,1  
loadcepc /B:9600 /C:1 c:\nk.bin
```

- d. Copy NK.BIN and HIMEM.SYS to c:\.
- e. Boot the system.

## Configuration

There are several issues to consider when configuring the display driver. The issues cover debugging support, register initialization values and memory allocation. Each of these issues is discussed in the following sections.

### Compile Switches

There are several switches, specific to the S1D13705 display driver, which affect the display driver.

The switches are added or removed from the compile options in the file SOURCES.

#### **WINCEVER**

This option is automatically set to the numerical version of WinCE for version 2.12 or later. If the environment variable, `_WINCEOSVER` is not defined, then `WINCEVER` will default 2.11. The S1D display driver may test against this option to support different WinCE version-specific features.

#### **EnablePreferVmem**

This option enables the use of off-screen video memory. When this option is enabled, WinCE can optimize some BLT operations by using off-screen video memory to store images. You may need to disable this option for systems with limited off-screen memory.

#### **EpsonMessages**

This debugging option enables the display of EPSON-specific debug messages. These debug messages are sent to the serial debugging port. This option should be disabled unless you are debugging the display driver, as they will significantly impact the performance of the display driver.

#### **DEBUG\_MONITOR**

This option enables the use of the debug monitor. The debug monitor can be invoked when the display driver is first loaded and can be used to view registers, and perform a few debugging tasks. The debug monitor is still under development and is UNTESTED.

This option should remain disabled unless you are performing specific debugging tasks that require the debug monitor.

## GrayPalette

This option is intended for the support of monochrome panels only.

The option causes palette colors to be grayscaled for correct display on a mono panel. For use with color panels this option should not be enabled.

## Mode File

The MODE tables (contained in files MODE0.H, MODE1.H, MODE2.H . . .) contain register information to control the desired display mode. The MODE tables must be generated by the configuration program 13705CFG.EXE. The display driver comes with example MODE tables.

By default, only MODE0.H is used by the display driver. New mode tables can be created using the 13705CFG program. Edit the #include section of MODE.H to add the new mode table.

If you only support a single display mode, you do not need to add any information to the WinCE registry. If, however, you support more than one display mode, you should create registry values (see below) that will establish the initial display mode. If your display driver contains multiple mode tables, and if you do not add any registry values, the display driver will default to the first mode table in your list.

To select which display mode the display driver should use upon boot, add the following lines to your PLATFORM.REG file:

```
[HKEY_LOCAL_MACHINE\Drivers\Display\S1D13705]
```

```
“Width”=dword:140  
“Height”=dword:F0  
“Bpp”=dword:8  
“Rotation”=dword:0  
“RefreshRate”=dword:3C  
“Flags”=dword:1
```

Note that all dword values are in hexadecimal, therefore 140h = 320, F0h = 240, and 3Ch = 60. The value for “Flags” should be 1 (LCD). When the display driver starts, it will read these values in the registry and attempt to match a mode table against them. All values must be present and valid for a match to occur, otherwise the display driver will default to the first mode table in your list.

A WinCE desktop application (or control panel applet) can change these registry values, and the display driver will select a different mode upon warmboot. This allows the display driver to support different display configurations and/or orientations. An example application that controls these registry values will be made available upon the next release of the display driver; preliminary alpha code is available by special request.

## Resource Management Issues

The Windows CE 3.0 OEM must deal with certain display driver issues relevant to Windows CE 3.0. These issues require the OEM balance factors such as: system vs. display memory utilization, video performance, and power off capabilities.

The section “Simple Display Driver Configuration” on page 15 provides a configuration which should work with most Windows CE platforms. This section is only intended as a means of getting started. Once the developer has a functional system, it is recommended to optimize the display driver configuration as described below in “Description of Windows CE Display Driver Issues”.

### Description of Windows CE Display Driver Issues

The following are some issues to consider when configuring the display driver to work with Windows CE:

1. When Windows CE enters the Suspend state (power-off), the LCD controller and display memory may lose power, depending on how the OEM sets up the system. If display memory loses power, all images stored in display memory are lost.

If power-off/power-on features are required, the OEM has several options:

- If display memory power is turned off, add code to the display driver to save any images in display memory to system memory before power-off, and add code to restore these images after power-on.
  - If display memory power is turned off, instruct Windows CE to redraw all images upon power-on. Unfortunately it is not possible to instruct Windows CE to redraw any off-screen images, such as icons, slider bars, etc., so in this case the OEM must also configure the display driver to never use off-screen memory.
  - Ensure that display memory never loses power.
2. Using off-screen display memory significantly improves display performance. For example, slider bars appear more smooth when using off-screen memory. To enable or disable the use of off-screen memory, edit the file: `x:\wince300\platform\cepc\drivers\display\S1D13705\sources`. In `SOURCES`, there is a line which, when uncommented, will instruct Windows CE to use off-screen display memory (if sufficient display memory is available):

```
CDEFINES=$(CDEFINES) -DEnablePreferVmem
```

3. In the file `PROJECT.REG` under CE 3.0, there is a key called `PORepaint` (search the Windows CE directories for `PROJECT.REG`). `PORepaint` is relevant when the Suspend state is entered or exited. `PORepaint` can be set to 0, 1, or 2 as described below:
  - a. `PORepaint=0`
    - This mode tells Windows CE not to save or restore display memory on suspend or resume.

- Since display data is not saved and not repainted, this is the FASTEST mode.
  - Main display data in display memory must NOT be corrupted or lost on suspend. The memory clock must remain running.
  - Off-screen data in display memory must NOT be corrupted or lost on suspend. The memory clock must remain running.
  - This mode cannot be used if power to the display memory is turned off.
- b. PORepaint=1
- This is the default mode for Windows CE.
  - This mode tells Windows CE to save the main display data to the system memory on suspend.
  - This mode is used if display memory power is going to be turned off when the system is suspended, and there is enough system memory to save the image.
  - Any off-screen data in display memory is LOST when suspended. Therefore off-screen memory usage must either be disabled in the display driver (i.e: EnablePreferVmem not defined in SOURCES file), or new OEM-specific code must be added to the display driver to save off-screen data to system memory when the system is suspended, and restored when resumed.
  - If off-screen data is used (provided that the OEM has provided code to save off-screen data when the system suspends), additional code must be added to the display driver's surface allocation routine to prevent the display driver from allocating the "main memory save region" in display memory. When WinCE OS attempts to allocate a buffer to save the main display data, WinCE OS marks the allocation request as preferring display memory. We believe this is incorrect. Code must be added to prevent this specific allocation from being allocated in display memory - it MUST be allocated from system memory.
  - Since the main display data is copied to system memory on suspend, and then simply copied back on resume, this mode is FAST, but not as fast as mode 0.
- c. PORepaint=2
- This mode tells WinCE to not save the main display data on suspend, and causes WinCE to REPAINT the main display on resume.
  - This mode is used if display memory power is going to be turned off when the system is suspended, and there is not enough system memory to save the image.
  - Any off-screen data in display memory is LOST, and since there is insufficient system memory to save display data, off-screen memory usage MUST be disabled.
  - When the system is resumed, WinCE instructs all running applications to repaint themselves. This is the SLOWEST of the three modes.

## Simple Display Driver Configuration

The following display driver configuration should work with most platforms running Windows CE. This configuration disables the use of off-screen display memory and forces the system to redraw the main display upon power-on.

1. This step disables the use of off-screen display memory.  
Edit the file `x:\wince300\platform\cepc\drivers\display\S1D13705\sources` and change the line

```
CDEFINES=$(CDEFINES) -DEnablePreferVmem
```

to

```
#CDEFINES=$(CDEFINES) -DEnablePreferVmem
```

2. This step causes the system to redraw the main display upon power-on. This step is only required if display memory loses power when Windows CE is shut down. If display memory is kept powered up (set the S1D13705 in powersave mode), then the display data will be maintained and this step can be skipped.

Search for the file PROJECT.REG in your Windows CE directories, and inside PROJECT.REG find the key PORepaint. Change PORepaint as follows:

```
“PORepaint”=dword:2
```

## Comments

- The display driver is CPU independent, allowing use of the driver for several Windows CE Platform Builder supported platforms.
- If you are running 13705CFG.EXE to produce multiple MODE tables, make sure you change the Mode Number in the WinCE tab for each mode table you generate. The display driver supports multiple mode tables, but only if each mode table has a unique mode number.
- At this time, the drivers have been tested on the x86 CPUs and have been built with Platform Builder v3.00.



# EPSON®



## S1D13705 Embedded Memory LCD Controller

# Interfacing to the Toshiba MIPS TMPR3912 Microprocessor

Document Number: X27A-G-004-02

Copyright © 2001 Epson Research and Development, Inc. All Rights Reserved.

Information in this document is subject to change without notice. You may download and use this document, but only for your own use in evaluating Seiko Epson/EPSON products. You may not modify the document. Epson Research and Development, Inc. disclaims any representation that the contents of this document are accurate or current. The Programs/Technologies described in this document may contain material protected under U.S. and/or International Patent laws.

EPSON is a registered trademark of Seiko Epson Corporation. All other trademarks are the property of their respective owners.

---

**THIS PAGE LEFT BLANK**

# Table of Contents

<b>1</b>	<b>Introduction</b>	<b>7</b>
<b>2</b>	<b>Interfacing to the TMPR3912</b>	<b>8</b>
<b>3</b>	<b>S1D13705 Host Bus Interface</b>	<b>9</b>
3.1	Host Bus Pin Connection	9
3.2	Generic #1 Interface Mode	10
3.3	Generic #2 Interface Mode	11
<b>4</b>	<b>Direct Connection to the Toshiba TMPR3912</b>	<b>12</b>
4.1	General Description	12
4.2	Memory Mapping and Aliasing	13
4.3	S1D13705 Configuration	13
<b>5</b>	<b>Using the ITE IT8368E PC Card Buffer</b>	<b>14</b>
5.1	Hardware Description	14
5.2	IT8368E Configuration	16
5.3	Memory Mapping and Aliasing	16
5.4	S1D13705 Configuration	17
<b>6</b>	<b>Software</b>	<b>18</b>
<b>7</b>	<b>Technical Support</b>	<b>19</b>
7.1	EPSON LCD Controllers (S1D13705)	19
7.2	Toshiba MIPS TMPR3912 Processor	19
7.3	ITE IT8368E	19

**THIS PAGE LEFT BLANK**

---

## List of Tables

Table 3-1: Host Bus Interface Pin Mapping . . . . .	9
Table 4-1: S1D13705 Configuration for Direct Connection. . . . .	13
Table 5-1: TMPR3912 to PC Card Slots Address Mapping With and Without the IT8368E. . . . .	16
Table 5-2: S1D13705 Configuration Using the IT8368E . . . . .	17

## List of Figures

Figure 4-1: S1D13705 to TMPR3912 Direct Connection . . . . .	12
Figure 5-1: S1D13705 to TMPR3912 Connection Using an IT8368E . . . . .	15

**THIS PAGE LEFT BLANK**

---

# 1 Introduction

This application note describes the hardware required to interface the S1D13705 Embedded Memory LCD Controller and the Toshiba MIPS TMPR3912 Processor. The pairing of these two devices results in an embedded system offering impressive display capability with very low power consumption.

The designs described in this document are presented only as examples of how such interfaces might be implemented. This application note will be updated as appropriate. Please check the Epson Electronics America website at <http://www.eea.epson.com> for the latest revision of this document before beginning any development.

We appreciate your comments on our documentation. Please contact us via email at [techpubs@erd.epson.com](mailto:techpubs@erd.epson.com).

## 2 Interfacing to the TMPR3912

The Toshiba MIPS TMPR3912 processor supports up to two PC Card (PCMCIA) slots. It is through this host bus interface that the S1D13705 connects to the TMPR3912 processor.

The S1D13705 can be successfully interfaced using one of two configurations:

- Direct connection to TMPR3912.
- System design using one ITE IT8368E PC Card/GPIO buffer chip.



## 3 S1D13705 Host Bus Interface

This section is a summary of the host bus interface modes available on the S1D13705 that would be used to interface to the TMPR3912.

The S1D13705 implements a 16-bit interface to the host microprocessor which may operate in one of several modes compatible with most of the popular embedded microprocessor families. The interface modes used for the TMPR3912 are:

- Generic #1 (Chip Select, plus individual Read Enable/Write Enable for each byte).
- Generic #2 (External Chip Select, shared Read/Write Enable for high byte, individual Read/Write Enable for low byte).

### 3.1 Host Bus Pin Connection

The following table shows the functions of each host bus interface signal.

*Table 3-1: Host Bus Interface Pin Mapping*

S1D13705 Pin Names	Generic #1	Generic #2
AB[15:1]	A[15:1]	A[15:1]
AB0	A0	A0
DB[15:0]	D[15:0]	D[15:0]
WE1#	WE1#	BHE#
CS#	External Decode	External Decode
BCLK	BCLK	BCLK
BS#	connect to $V_{SS}$	connect to IO $V_{DD}$
RD/WR#	RD1#	connect to IO $V_{DD}$
RD#	RD0#	RD#
WE0#	WE0#	WE#
WAIT#	WAIT#	WAIT#
RESET#	RESET#	RESET#

For configuration details, refer to the *S1D13705 Hardware Functional Specification*, document number X27A-A-001-xx.

## 3.2 Generic #1 Interface Mode

Generic #1 interface mode is the most general and least processor-specific interface mode on the S1D13705. The Generic # 1 interface mode was chosen for this interface due to the simplicity of its timing.

The interface requires the following signals:

- BUSCLK is a clock input which is required by the S1D13705 host interface. It is separate from the input clock (CLKI) and is typically driven by the host CPU system clock.
- The address inputs AB0 through AB16, and the data bus DB0 through DB15, connect directly to the CPU address and data bus, respectively. On 32-bit big endian architectures such as the Power PC, the data bus would connect to the high-order data lines; on little endian hosts, or 16-bit big endian hosts, they would connect to the low-order data lines. The hardware engineer must ensure that CNF3 selects the proper endian mode upon reset.
- Chip Select (CS#) is driven by decoding the high-order address lines to select the proper register and memory address space.
- WE0# and WE1# are write enables for the low-order and high-order bytes, respectively, to be driven low when the host CPU is writing data to the S1D13705. These signals must be generated by external hardware based on the control outputs from the host CPU.
- RD# and RD/WR# are read enables for the low-order and high-order bytes, respectively, to be driven low when the host CPU is reading data from the S1D13705. These signals must be generated by external hardware based on the control outputs from the host CPU.
- WAIT# is a signal output from the S1D13705 that indicates the host CPU must wait until data is ready (read cycle) or accepted (write cycle) on the host bus. Since host CPU accesses to the S1D13705 may occur asynchronously to the display update, it is possible that contention may occur in accessing the S1D13705 internal registers and/or refresh memory. The WAIT# line resolves these contentions by forcing the host to wait until the resource arbitration is complete. This signal is active low and may need to be inverted if the host CPU wait state signal is active high.
- The Bus Status (BS#) signal is not used in the bus interface for Generic #1 mode. However, BS# is used to configure the S1D13705 for Generic #1 mode and should be tied low (connected to GND).

### 3.3 Generic #2 Interface Mode

Generic #2 interface mode is a general and non-processor-specific interface mode on the S1D13705. The Generic # 2 interface mode was chosen for this interface due to the simplicity of its timing and compatibility with the TMPR3912 control signals.

The interface requires the following signals:

- BUSCLK is a clock input which synchronizes transfers between the host CPU and the S1D13705. It is separate from the input clock (CLKI) and is typically driven by the host CPU system clock.
- The address inputs AB0 through AB16, and the data bus DB0 through DB15, connect directly to the CPU address and data bus, respectively. On 32-bit big endian architectures such as the Power PC, the data bus would connect to the high-order data lines; on little endian hosts, or 16-bit big endian hosts, they would connect to the low-order data lines. The hardware engineer must ensure that CNF3 selects the proper endian mode upon reset.
- Chip Select (CS#) is driven by decoding the high-order address lines to select the proper register and memory address space.
- WE1# is the high byte enable for both read and write cycles for the S1D13705, to be driven low when the host CPU accesses the S1D13705.
- WE0# is the write enable for the S1D13705, to be driven low when the host CPU is reading data from the S1D13705.
- RD# is the read enable for the S1D13705, to be driven low when the host CPU is reading data from the S1D13705.
- WAIT# is a signal which is output from the S1D13705 to the host CPU that indicates when data is ready (read cycle) or accepted (write cycle) on the host bus. Since host CPU accesses to the S1D13705 may occur asynchronously to the display update, it is possible that contention may occur in accessing the 13705 internal registers and/or refresh memory. The WAIT# line resolves these contentions by forcing the host to wait until the resource arbitration is complete. This signal is active low and may need to be inverted if the host CPU wait state signal is active high.
- The Bus Status (BS#) and Read/Write (RD/WR#) signals are not used in the bus interface for Generic #2 mode. However, BS# is used to configure the S1D13705 for Generic #2 mode and should be tied high (connected to IO V<sub>DD</sub>). RD/WR# should also be tied high.

## 4 Direct Connection to the Toshiba TMPR3912

### 4.1 General Description

In this example implementation, the S1D13705 occupies the TMPR3912 PC Card slot #1.

The S1D13705 is easily interfaced to the TMPR3912 with minimal additional logic. The address bus of the TMPR3912 PC Card interface is multiplexed and must be demultiplexed using an advanced CMOS latch (e.g., 74AHC373). The direct connection approach makes use of the S1D13705 in its “Generic Interface #2” configuration.

The following diagram demonstrates a typical implementation of the interface.

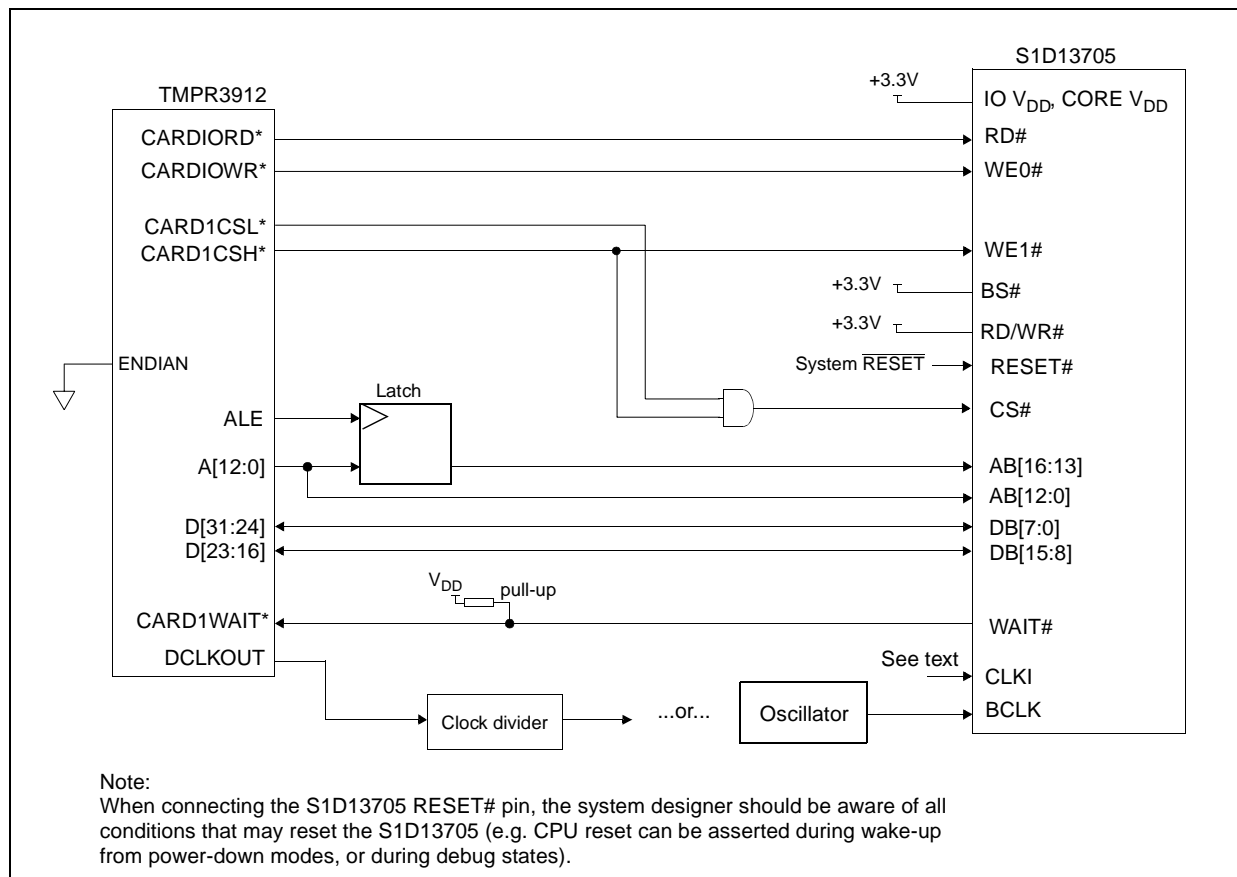

Figure 4-1: S1D13705 to TMPR3912 Direct Connection

#### Note

See Section 3.1 on page 9 and Section 3.3 on page 11 for Generic #2 pin descriptions.

The “Generic #2” host interface control signals of the S1D13705 are asynchronous with respect to the S1D13705 bus clock. This gives the system designer full flexibility to choose the appropriate source (or sources) for CLKI and BCLK. The choice of whether both clocks should be the same, and whether to use DCLKOUT (divided) as clock source, should be based on the desired:

- pixel and frame rates.
- power budget.
- part count.
- maximum S1D13705 clock frequencies.

The S1D13705 also has internal clock dividers providing additional flexibility.

## 4.2 Memory Mapping and Aliasing

In this example implementation the TMPR3912 control signal CARDREG\* is ignored; therefore the S1D13705 takes up the entire PC Card slot 1.

The S1D13705 requires an addressing space of 128K bytes. The on-chip display memory occupies the range 0 through 13FFFh. The registers occupy the range 1FFE0h through 1FFFFh. The TMPR3912 demultiplexed address lines A17 and above are ignored, thus the S1D13705 is aliased 512 times at 128K byte intervals over the 64M byte PC Card slot #1 memory space.

### Note

If aliasing is undesirable, additional decoding circuitry must be added.

## 4.3 S1D13705 Configuration

The S1D13705 is configured at power up by latching the state of the CNF[3:0] pins. Pin BS# also plays a role in host bus interface configuration. For details on configuration, refer to the *S1D13705 Hardware Functional Specification*, document number X27A-A-001-xx.

The table below shows those configuration settings relevant to the direct connection approach.

Table 4-1: S1D13705 Configuration for Direct Connection

S1D13705 Configuration Pin	Value hard wired on this pin is used to configure:	
	1 (IO V <sub>DD</sub> )	0 (V <sub>SS</sub> )
BS#	Generic #2	Generic #1
CNF3	Big Endian	Little Endian
CNF[2:0]	111: Generic #1 or #2	

= configuration for Toshiba TMPR3912 host bus interface

## 5 Using the ITE IT8368E PC Card Buffer

If the system designer uses the ITE IT8368E PC Card and multiple-function I/O buffer, the S1D13705 can be interfaced so that it “shares” a PC Card slot. The S1D13705 is mapped to a rarely-used 16M byte portion of the PC Card slot buffered by the IT8368E, making the S1D13705 virtually transparent to PC Card devices that use the same slot.

### 5.1 Hardware Description

The ITE8368E has been specially designed to support EPSON LCD controllers and provides eleven Multi-Function IO pins (MFIO). Configuration registers may be used to allow these MFIO pins to provide the control signals required to implement the S1D13705 CPU interface.

The TMPR3912 processor only provides addresses A[12:0], therefore devices requiring more address space must use an external device to latch A[25:13]. The IT8368E’s MFIO pins can be configured to provide this latched address.

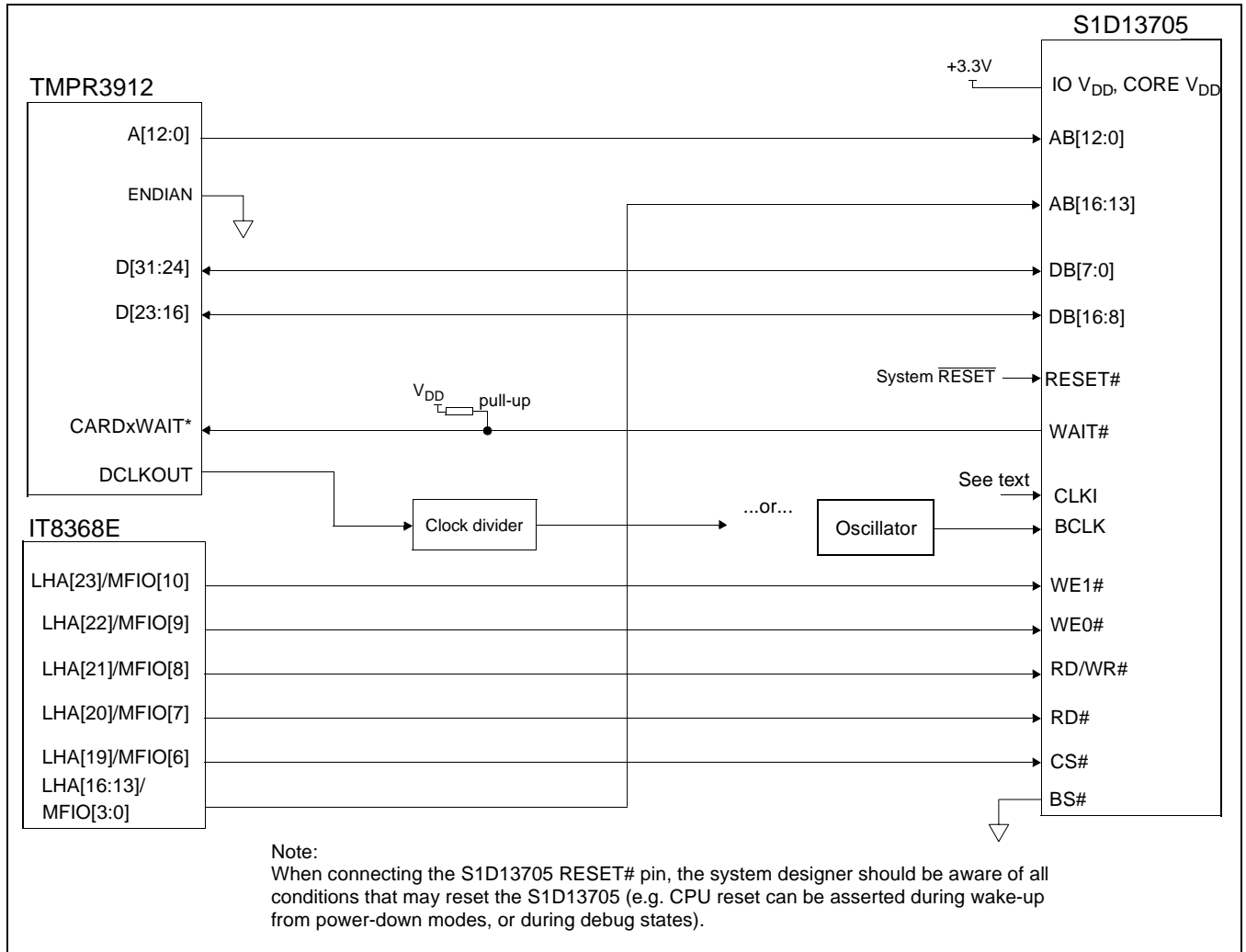

Figure 5-1: S1D13705 to TMPR3912 Connection Using an IT8368E

**Note**

See Section 3.1 on page 9 and Section 3.2 on page 10 for Generic #1 pin descriptions.

The “Generic #1” host interface control signals of the S1D13705 are asynchronous with respect to the S1D13705 bus clock. This gives the system designer full flexibility to choose the appropriate source (or sources) for CLKI and BCLK. The choice of whether both clocks should be the same, and whether to use DCLKOUT (divided) as clock source, should be based on pixel and frame rates, power budget, part count and maximum S1D13705 respective clock frequencies. Also, internal S1D13705 clock dividers provide additional flexibility.

## 5.2 IT8368E Configuration

The IT8368E provides eleven multi-function IO pins (MFIO). The IT8368E must have both “Fix Attribute/IO” and “VGA” modes on. When both these modes are enabled, the MFIO pins provide control signals needed by the S1D13705 host bus interface, and a 16M byte portion of the system PC Card attribute and IO space is allocated to address the S1D13705. When accessing the S1D13705 the associated card-side signals are disabled in order to avoid any conflicts.

For mapping details, refer to section 3.3: “Memory Mapping and Aliasing.” For connection details see Figure 5-1: “S1D13705 to TMPR3912 Connection Using an IT8368E,” on page 15. For further information on the IT8368E, refer to the *IT8368E PC Card/GPIO Buffer Chip Specification*.

### Note

When a second IT8368E is used, that circuit should not be set in VGA mode.

## 5.3 Memory Mapping and Aliasing

When the TMPR3912 accesses the PC Card slots *without* the ITE IT8368E, its system memory is mapped as in Table 5-1: *TMPR3912 to PC Card Slots Address Mapping With and Without the IT8368E*.

### Note

Bit CARD1IOEN or CARD2IOEN, depending on which card slot is used, must to be set to 0 in the TMPR3912 Memory Configuration Register 3.

When the TMPR3912 accesses the PC Card slots buffered through the ITE IT8368E, bits CARD1IOEN and CARD2IOEN are ignored and the attribute/IO space of the TMPR3912 is divided into Attribute, I/O and S1D13705 access. Details of the Attribute/IO address reallocation by the IT8368E are found in Table 5-1: *TMPR3912 to PC Card Slots Address Mapping With and Without the IT8368E*.

Table 5-1: *TMPR3912 to PC Card Slots Address Mapping With and Without the IT8368E*

PC Card Slot #	TMPR3912 Address	Size	Using the ITE IT8368E	Direct Connection, CARDnIOEN=0	Direct Connection, CARDnIOEN=1
1	0800 0000h	16M byte	Card 1 IO	S1D13705 (aliased 512 times at 128K byte intervals)	Card 1 IO
	0900 0000h	16M byte	S1D13705 (aliased 128 times at 128K byte intervals)		
	0A00 0000h	32M byte	Card 1 Attribute		
	6400 0000h	64M byte	Card 1 Memory	S1D13705 (aliased 512 times at 128K byte intervals)	



Table 5-1: Tmpr3912 to PC Card Slots Address Mapping With and Without the IT8368E

PC Card Slot #	Tmpr3912 Address	Size	Using the ITE IT8368E	Direct Connection, CARDnIOEN=0	Direct Connection, CARDnIOEN=1
2	0C00 0000h	16M byte	Card 2 IO	S1D13705 (aliased 512 times at 128K byte intervals)	Card 2 IO
	0D00 0000h	16M byte	S1D13705 (aliased 128 times at 128K byte intervals)		
	0E00 0000h	32M byte	Card 2 Attribute		
	6800 0000h	64M byte	Card 2 Memory	S1D13705 (aliased 512 times at 128K byte intervals)	

## 5.4 S1D13705 Configuration

The S1D13705 is configured at power up by latching the state of the CNF[3:0] pins. Pin BS# also plays a role in host bus interface configuration. For details on configuration, refer to the *S1D13705 Hardware Functional Specification*, document number X26A-A-001-xx.

The table below shows those configuration settings relevant to this specific interface.

Table 5-2: S1D13705 Configuration Using the IT8368E

S1D13705 Configuration Pin	Value hard wired on this pin is used to configure:	
	1 (IO V <sub>DD</sub> )	0 (V <sub>SS</sub> )
BS#	Generic #2	Generic #1
CNF3	Big Endian	Little Endian
CNF[2:0]	111: Generic #1 or #2	

= configuration for connection using ITE IT8368E

## 6 Software

Test utilities and Windows® CE v2.0 display drivers are available for the S1D13705. Full source code is available for both the test utilities and the drivers.

The test utilities are configurable for different panel types using a program called 1357CFG, or by directly modifying the source. The Windows CE v2.0 display drivers can be customized by the OEM for different panel types, resolutions and color depths only by modifying the source.

The S1D13705 test utilities and Windows CE v2.0 display drivers are available from your sales support contact or [www.eea.epson.com](http://www.eea.epson.com).

## 7 Technical Support

### 7.1 EPSON LCD Controllers (S1D13705)

#### Japan

Seiko Epson Corporation  
Electronic Devices Marketing Division  
421-8, Hino, Hino-shi  
Tokyo 191-8501, Japan  
Tel: 042-587-5812  
Fax: 042-587-5564

#### North America

Epson Electronics America, Inc.  
150 River Oaks Parkway  
San Jose, CA 95134, USA  
Tel: (408) 922-0200  
Fax: (408) 922-0238  
<http://www.eea.epson.com>

#### Taiwan, R.O.C.

Epson Taiwan Technology  
& Trading Ltd.  
10F, No. 287  
Nanking East Road  
Sec. 3, Taipei, Taiwan, R.O.C.  
Tel: 02-2717-7360  
Fax: 02-2712-9164

#### Europe

Epson Europe Electronics GmbH  
Riesstrasse 15  
80992 Munich, Germany  
Tel: 089-14005-0  
Fax: 089-14005-110

#### Hong Kong

Epson Hong Kong Ltd.  
20/F., Harbour Centre  
25 Harbour Road  
Wanchai, Hong Kong  
Tel: 2585-4600  
Fax: 2827-4346

#### Singapore

Epson Singapore Pte., Ltd.  
No. 1  
Temasek Avenue #36-00  
Millenia Tower  
Singapore, 039192  
Tel: 337-7911  
Fax: 334-2716

### 7.2 Toshiba MIPS Tmpr3912 Processor

<http://www.toshiba.com/taec/nonflash/indexproducts.html>

### 7.3 ITE IT8368E

#### Integrated Technology Express, Inc.

Sales & Marketing Division  
2710 Walsh Avenue  
Santa Clara, CA 95051, USA  
Tel: (408) 980-8168  
Fax: (408) 980-9232  
<http://www.iteusa.com>

**THIS PAGE LEFT BLANK**



## **S1D13705 Embedded Memory LCD Controller**

# **S1D13705 Power Consumption**

**Document Number: X27A-G-006-02**

Copyright © 2001 Epson Research and Development, Inc. All Rights Reserved.

Information in this document is subject to change without notice. You may download and use this document, but only for your own use in evaluating Seiko Epson/EPSON products. You may not modify the document. Epson Research and Development, Inc. disclaims any representation that the contents of this document are accurate or current. The Programs/Technologies described in this document may contain material protected under U.S. and/or International Patent laws.

EPSON is a registered trademark of Seiko Epson Corporation. All other Trademarks are the property of their respective owners

---

**THIS PAGE LEFT BLANK**

# 1 S1D13705 Power Consumption

S1D13705 power consumption is affected by many system design variables.

- Input clock frequency (CLKI): the CLKI frequency and the internal clock divide register determine the operating clock (CLK) frequency of the S1D13705. The higher CLK is, the higher the frame rate, performance, and power consumption.
- CPU interface: the S1D13705 current consumption depends on the BUSCLK frequency, data width, number of toggling pins, and other factors – the higher the BUSCLK, the higher the CPU performance and power consumption.
- $V_{DD}$  voltage levels (Core and IO): the voltage level of the Core and IO sections in the S1D13705 affects power consumption – the higher the voltage, the higher the consumption.
- Display mode: the resolution, panel type, and color depth affect power consumption. The higher the resolution/color depth and number of LCD panel signals, the higher the power consumption.

## Note

If the High Performance option is turned on, the power consumption increases to that of 8 bit-per-pixel mode for all color depths.

There are two power save modes in the S1D13705: Software and Hardware Power Save. The power consumption of these modes is affected by various system design variables.

- CPU bus state during Power Save: the state of the CPU bus signals during Power Save has a substantial effect on power consumption. An inactive bus (e.g. BUSCLK = low, Addr = low etc.) reduces overall system power consumption.
- CLKI state during Power Save: disabling the CLKI during Power Save has substantial power savings.

## 1.1 Conditions

Table 1-1: “SID13705 Total Power Consumption” below gives an example of a specific environment and its effects on power consumption.

Table 1-1: SID13705 Total Power Consumption

Test Condition <i>Core V<sub>DD</sub> = 3.3V, IO V<sub>DD</sub> = 3.3V BUSCLK = 8.33MHz</i>		Gray Shades / Colors	Power Consumption				
			Active			Power Save Mode	
			Core	IO	Total	Software	Hardware
1	Input Clock = 6MHz LCD Panel = 320x240 4-bit Single Monochrome	Black-and-White	4.29mW	0.52mW	4.81mW	1.44mW <sup>1</sup>	1.21mW <sup>2</sup>
		4 Gray Shades	4.99mW	0.76mW	5.75mW		
		16 Gray Shades	6.13mW	0.75mW	6.88mW		
2	Input Clock = 6MHz LCD Panel = 320x240 4-bit Single Color	2 Colors	4.64mW	0.73mW	5.37mW	1.44mW <sup>1</sup>	1.22mW <sup>2</sup>
		4 Colors	5.30mW	1.51mW	6.81mW		
		16 Colors	6.58mW	1.57mW	8.15mW		
		256 Colors	8.65mW	1.52mW	10.16mW		
3	Input Clock = 25MHz LCD Panel = 640x480 8-bit Single Monochrome	Black-and-White	13.97mW	1.10mW	15.07mW	2.53mW <sup>1</sup>	2.32mW <sup>2</sup>
		4 Gray Shades	16.75mW	2.08mW	18.83mW		
4	Input Clock = 25MHz LCD Panel = 640x480 8-bit Single Color	2 Colors	15.53mW	2.64mW	18.17mW	2.53mW <sup>1</sup>	2.32mW <sup>2</sup>
		4 Colors	18.30mW	7.16mW	25.47mW		
5	Input Clock = 25MHz LCD Panel = 640x480 8-bit Dual Monochrome	Black-and-White 4 Grey Shades	13.84mW 20.38mW	1.08mW 2.07mW	14.93mW 22.45mW	2.53mW <sup>1</sup>	2.32mW <sup>2</sup>
6	Input Clock = 25MHz LCD Panel = 640x480 8-bit Dual Color	2 Colors 4 Colors	15.82mW 23.31mW	2.62mW 7.01mW	18.44mW 30.32mW	2.53mW <sup>1</sup>	2.32mW <sup>2</sup>
7	Input Clock = 25MHz LCD Panel = 640x480 9-bit TFT	2 Colors 4 Colors	11.42mW 19.74mW	7.40mW 20.96mW	18.82mW 40.70mW	2.53mW <sup>1</sup>	2.32mW <sup>2</sup>

### Note

- Conditions for Software Power Save:
  - CPU interface active (signals toggling)
  - CLKI active
- Conditions for Hardware Power Save:
  - CPU interface inactive (high impedance)
  - CLKI active



## 2 Summary

The system design variables in Section 1, “S1D13705 Power Consumption” and in Table 1-1: “S1D13705 Total Power Consumption” show that S1D13705 power consumption depends on the specific implementation. Active Mode power consumption depends on the desired CPU performance and LCD frame-rate, whereas Power Save Mode consumption depends on the CPU Interface and Input Clock state.

In a typical design environment, the S1D13705 can be configured to be an extremely power-efficient LCD Controller with high performance and flexibility.

**THIS PAGE LEFT BLANK**

# EPSON®



## S1D13705 Embedded Memory LCD Controller

# Interfacing to the Motorola 'Dragonball' Family of Microprocessors

Document Number: X27A-G-007-04

Copyright © 2001 Epson Research and Development, Inc. All Rights Reserved.

Information in this document is subject to change without notice. You may download and use this document, but only for your own use in evaluating Seiko Epson/EPSON products. You may not modify the document. Epson Research and Development, Inc. disclaims any representation that the contents of this document are accurate or current. The Programs/Technologies described in this document may contain material protected under U.S. and/or International Patent laws.

EPSON is a registered trademark of Seiko Epson Corporation. All Trademarks are the property of their respective owners.

---

**THIS PAGE LEFT BLANK**

# Table of Contents

<b>1</b>	<b>Introduction</b>	<b>7</b>
<b>2</b>	<b>Interfacing to the MC68328</b>	<b>8</b>
2.1	The MC68328 System Bus	8
2.2	Chip-Select Module	8
2.3	S1D13705 Host Bus Interface	9
2.3.1	Host Bus Pin Connection	9
2.3.2	Generic #1 Interface Mode	10
2.3.3	MC68K #1 Interface Mode	11
2.4	MC68328 To S1D13705 Interface	12
2.4.1	Hardware Description	12
2.4.2	S1D13705 Hardware Configuration	14
2.4.3	MC68328 Chip Select Configuration	14
<b>3</b>	<b>Interfacing to the MC68EZ328</b>	<b>15</b>
3.1	The MC68EZ328 System Bus	15
3.2	Chip-Select Module	15
3.3	S1D13705 Host Bus Interface	16
3.3.1	Host Bus Pin Connection	16
3.3.2	Generic #1 Interface Mode	17
3.4	MC683EZ28 To S1D13705 Interface	18
3.4.1	Hardware Description	18
3.4.2	S1D13705 Hardware Configuration	19
3.4.3	MC68EZ328 Chip Select Configuration	19
<b>4</b>	<b>Interfacing to the MC68VZ328</b>	<b>20</b>
4.1	The MC68VZ328 System Bus	20
4.2	Chip-Select Module	20
4.3	S1D13705 Host Bus Interface	21
4.3.1	Host Bus Pin Connection	21
4.3.2	Generic #1 Interface Mode	22
4.3.3	MC68K #1 Interface Mode	23
4.4	MC68VZ328 To S1D13705 Interface	24
4.4.1	Hardware Description	24
4.4.2	S1D13705 Hardware Configuration	26
4.4.3	MC68VZ328 Chip Select and Pin Configuration	27
<b>5</b>	<b>Software</b>	<b>28</b>
<b>6</b>	<b>References</b>	<b>29</b>
6.1	Documents	29

6.2 Document Sources . . . . .29

**7 Technical Support . . . . .30**

7.1 EPSON LCD Controllers (S1D13705) . . . . .30

7.2 Motorola Dragonball Processors . . . . .30

---

## List of Tables

Table 2-1: Host Bus Interface Pin Mapping . . . . .	9
Table 2-2: Summary of Power-On/Reset Options . . . . .	14
Table 2-3: Host Bus Interface Selection . . . . .	14
Table 3-1: Host Bus Interface Pin Mapping . . . . .	16
Table 3-2: Summary of Power-On/Reset Options . . . . .	19
Table 3-3: Host Bus Interface Selection . . . . .	19
Table 4-1: Host Bus Interface Pin Mapping . . . . .	21
Table 4-2: Summary of Power-On/Reset Options . . . . .	26
Table 4-3: Host Bus Interface Selection . . . . .	26

## List of Figures

Figure 2-1: Typical Implementation of MC68328 to S1D13705 Interface - MC68K #1 . . . . .	12
Figure 2-2: Typical Implementation of MC68328 to S1D13705 Interface - Generic #1 . . . . .	13
Figure 3-1: Typical Implementation of MC68EZ328 to S1D13705 Interface - Generic #1 . . . . .	18
Figure 4-1: Typical Implementation of MC68VZ328 to S1D13705 Interface - MC68K #1 . . . . .	24
Figure 4-2: Typical Implementation of MC68VZ328 to S1D13705 Interface - Generic #1 . . . . .	25

**THIS PAGE LEFT BLANK**



# 1 Introduction

This application note describes the hardware required to interface the S1D13705 Embedded Memory LCD Controller and the Motorola “Dragonball” family of microprocessors. Each “Dragonball” microprocessor, the MC68328, the MC68EZ328, and the MC68VZ328, will be described in their own sections.

By implementing an embedded display refresh buffer, the S1D13705 can reduce system power consumption, improve image quality, and increase system performance as compared to the Dragonball’s on-chip LCD controller.

The designs described in this document are presented only as examples of how such interfaces might be implemented. This application note will be updated as appropriate. Please check the Epson Electronics America website at <http://www.eea.epson.com> for the latest revision of this document before beginning any development.

We appreciate your comments on our documentation. Please contact us via email at [documentation@erd.epson.com](mailto:documentation@erd.epson.com).

## 2 Interfacing to the MC68328

### 2.1 The MC68328 System Bus

The MC68328 is the first generation of Motorola's Dragonball microprocessors. The MC68328 is an integrated controller for handheld products, based upon the MC68EC000 microprocessor core. It implements a 16-bit data bus and a 32-bit address bus. The bus interface consists of all the standard MC68EC000 bus interface signals, plus some new signals intended to simplify the task of interfacing to typical memory and peripheral devices.

The MC68EC000 bus control signals are well documented in Motorola's user manuals, and will not be described here. A brief summary of the new signals appears below:

- Output Enable ( $\overline{OE}$ ) is asserted when a read cycle is in process; it is intended to connect to the output enable control of a typical static RAM, EPROM, or Flash EPROM device.
- Upper Write Enable and Lower Write Enable ( $\overline{UWE}$  /  $\overline{LWE}$ ) are asserted during memory write cycles for the upper and lower bytes of the 16-bit data bus; they may be directly connected to the write enable inputs of a typical memory device.

The S1D13705 implements the MC68EC000 bus interface using its MC68K #1 mode, so this mode may be used to connect the MC68328 directly to the S1D13705 with no glue logic. However, several of the MC68EC000 bus control signals are multiplexed with IO and interrupt signals on the MC68328, and in many applications it may be desirable to make these pins available for these alternate functions. This requirement may be accommodated through the use of the Generic #1 interface mode on the S1D13705.

### 2.2 Chip-Select Module

The MC68328 can generate up to 16 chip select outputs, organized into four groups, "A" through "D".

Each chip select group has a common base address register and address mask register, to set the base address and block size of the entire group. In addition, each chip select within a group has its own address compare and address mask register, to activate the chip select for a subset of the group's address block. Finally, each chip select may be individually programmed to control an 8 or 16-bit device, and each may be individually programmed to generate from 0 through 6 wait states internally, or allow the memory or peripheral device to terminate the cycle externally through use of the standard MC68000  $\overline{DTACK}$  signal.

Groups A and B can have a minimum block size of 64K bytes, so these are typically used to control memory devices. Chip select A0 is active immediately after reset, so it is typically used to control a boot EPROM device. Groups C and D have a minimum block size of 4K bytes, so they are well-suited to controlling peripheral devices. Chip select D3 is associated with the MC68328 on-chip PCMCIA control logic.

## 2.3 S1D13705 Host Bus Interface

This section is a summary of the host bus interface modes available on the S1D13705 that may be used to interface to the MC68328.

The S1D13705 implements a 16-bit interface to the host microprocessor which may operate in one of several modes compatible with most of the popular embedded microprocessor families. The two interface modes that may be used for the MC68328 are:

- Motorola MC68K #1 (using Upper Data Strobe / Lower Data Strobe).
- Generic #1 (Chip Select, plus individual Read Enable/Write Enable for each byte).

### 2.3.1 Host Bus Pin Connection

The following table shows the functions of each host bus interface signal.

*Table 2-1: Host Bus Interface Pin Mapping*

S1D13705 Pin Names	MC68K #1	Generic #1
AB[15:1]	A[15:1]	A[15:1]
AB0	$\overline{\text{LDS}}$	A0
DB[15:0]	D[15:0]	D[15:0]
WE1#	$\overline{\text{UDS}}$	WE1#
CS#	External Decode	External Decode
BCLK	CLK	BCLK
BS#	$\overline{\text{AS}}$	connect to $V_{SS}$
RD/WR#	$\overline{\text{R/W}}$	RD1#
RD#	connect to IO $V_{DD}$	RD0#
WE0#	connect to IO $V_{DD}$	WE0#
WAIT#	$\overline{\text{DTACK}}$	WAIT#
RESET#	RESET#	RESET#

For details on configuration, refer to the *S1D13705 Hardware Functional Specification*, document number X27A-A-001-xx.

## 2.3.2 Generic #1 Interface Mode

Generic #1 interface mode is the most general and least processor-specific interface mode on the S1D13705. The Generic # 1 interface mode was chosen for this interface due to the simplicity of its timing.

The interface requires the following signals:

- BUSCLK is a clock input which is required by the S1D13705 host interface. It is separate from the input clock (CLKI) and is typically driven by the host CPU system clock.
- The address inputs AB0 through AB16, and the data bus DB0 through DB15, connect directly to the CPU address and data bus, respectively. On 32-bit big endian architectures such as the Power PC, the data bus would connect to the high-order data lines; on little endian hosts, or 16-bit big endian hosts, they would connect to the low-order data lines. The hardware engineer must ensure that CNF3 selects the proper endian mode upon reset.
- Chip Select (CS#) is driven by decoding the high-order address lines to select the proper register and memory address space.
- WE0# and WE1# are write enables for the low-order and high-order bytes, respectively, to be driven low when the host CPU is writing data to the S1D13705. These signals must be generated by external hardware based on the control outputs from the host CPU.
- RD# and RD/WR# are read enables for the low-order and high-order bytes, respectively, to be driven low when the host CPU is reading data from the S1D13705. These signals must be generated by external hardware based on the control outputs from the host CPU.
- WAIT# is a signal output from the S1D13705 that indicates the host CPU must wait until data is ready (read cycle) or accepted (write cycle) on the host bus. Since host CPU accesses to the S1D13705 may occur asynchronously to the display update, it is possible that contention may occur in accessing the S1D13705 internal registers and/or refresh memory. The WAIT# line resolves these contentions by forcing the host to wait until the resource arbitration is complete. This signal is active low and may need to be inverted if the host CPU wait state signal is active high.
- The Bus Status (BS#) signal is not used in the bus interface for Generic #1 mode. However, BS# is used to configure the S1D13705 for Generic #1 mode and should be tied low (connected to GND).

### 2.3.3 MC68K #1 Interface Mode

The MC68K #1 Interface Mode can be used to interface to the MC68328 microprocessor if the previously mentioned, multiplexed, bus signals will not be used for other purposes.

The interface requires the following signals:

- BUSCLK is a clock input which synchronizes transfers between the host CPU and the S1D13705. It is separate from the input clock (CLKI) and is typically driven by the host CPU system clock.
- The address inputs AB1 through AB16, and the data bus DB0 through DB15, connect directly to the CPU address and data bus, respectively. On 32-bit big endian architectures such as the Power PC, the data bus would connect to the high-order data lines; on little endian hosts, or 16-bit big endian hosts, they would connect to the low-order data lines. The hardware engineer must ensure that CNF3 selects the proper endian mode upon reset.
- Chip Select (CS#) is driven by decoding the high-order address lines to select the proper register and memory address space.
- A0 and WE1# are the enables for the low-order and high-order bytes, respectively, to be driven low when the host CPU is reading or writing data to the S1D13705.
- RD/WR# is the read/write signal that is driven low when the CPU writes to the S1D13705 and is driven high when the CPU is doing a read from the S1D13705.
- WAIT# is a signal which is output from the S1D13705 to the host CPU that indicates when data is ready (read cycle) or accepted (write cycle) on the host bus. Since host CPU accesses to the S1D13705 may occur asynchronously to the display update, it is possible that contention may occur in accessing the S1D13705 internal registers and/or refresh memory. The WAIT# line resolves these contentions by forcing the host to wait until the resource arbitration is complete.
- The Bus Status (BS#) signal indicates that the address on the address bus is valid.
- The WE0# and RD# signals is not used in the bus interface for MC68K #1 and must be tied high (tied to IO V<sub>DD</sub>).

## 2.4 MC68328 To S1D13705 Interface

### 2.4.1 Hardware Description

The interface between the MC68328 and the S1D13705 can be implemented using either the MC68K #1 or Generic #1 host bus interface of the S1D13705.

#### Using The MC68K #1 Host Bus Interface

The MC68328 multiplexes dual functions on some of its bus control pins (specifically  $\overline{UDS}$ ,  $\overline{LDS}$ , and  $\overline{DTACK}$ ). In implementations where all of these pins are available for use as bus control pins, then the S1D13705 interface is a straightforward implementation of the “MC68K #1” host bus interface.

The following diagram shows a typical implementation of the MC68328 to S1D13705 using the MC68K #1 host bus interface. For further information on the MC68K #1 host bus interface and AC Timing, refer to the *S1D13705 Hardware Functional Specification*, document number X27A-A-001-xx.

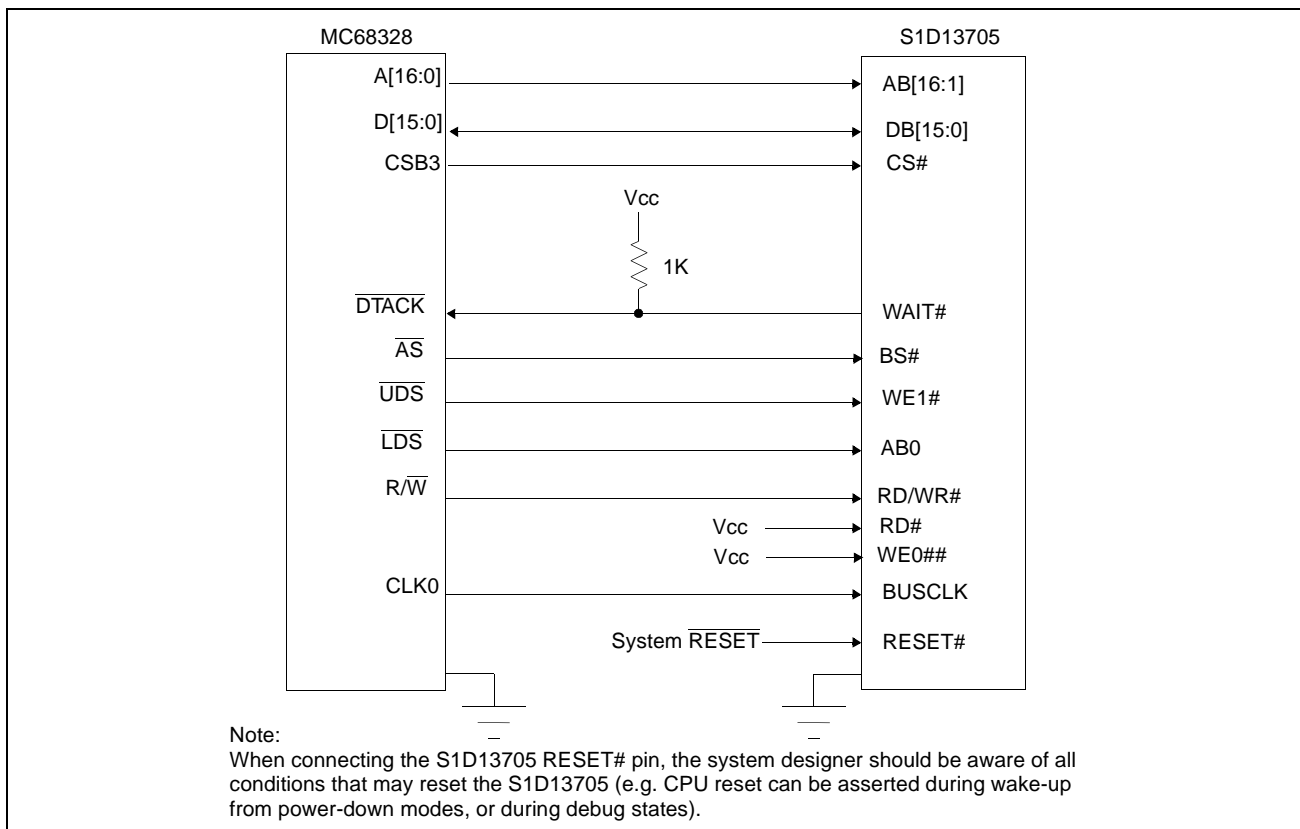

Figure 2-1: Typical Implementation of MC68328 to S1D13705 Interface - MC68K #1

## Using The Generic #1 Host Bus Interface

If  $\overline{UDS}$  and/or  $\overline{LDS}$  are required for their alternate IO functions, then the MC68328 to S1D13705 interface may be implemented using the S1D13705 Generic #1 host bus interface. Note that in either case, the  $\overline{DTACK}$  signal must be made available for the S1D13705, since it inserts a variable number of wait states depending upon CPU/LCD synchronization and the LCD panel display mode.  $\overline{WAIT\#}$  must be inverted (using an inverter enabled by CS#) to make it an active high signal and thus compatible with the MC68328 architecture. A single resistor is used to pull up the  $\overline{WAIT\#}$  ( $\overline{DTACK}$ ) signal when terminating the bus cycle.

The following diagram shows a typical implementation of the MC68328 to S1D13705 using the Generic #1 host bus interface. For further information on the Generic #1 host bus interface and AC Timing, refer to the *S1D13705 Hardware Functional Specification*, document number X27A-A-001-xx.

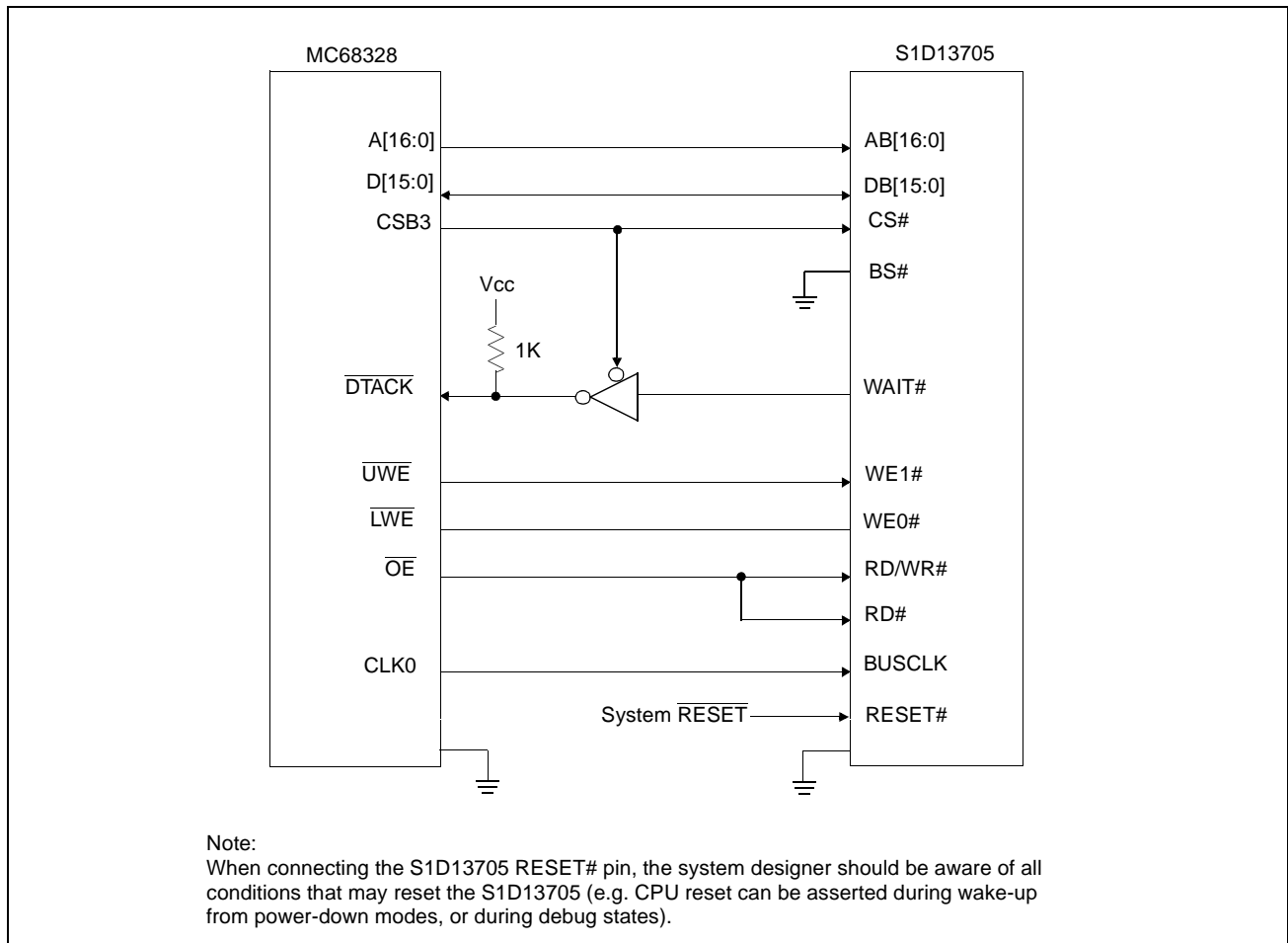

Figure 2-2: Typical Implementation of MC68328 to S1D13705 Interface - Generic #1

## 2.4.2 S1D13705 Hardware Configuration

The S1D13705 uses CNF3 through CNF0 and BS# to allow selection of the bus mode and other configuration data on the rising edge of RESET#. Refer to the *S1D13705 Hardware Functional Specification*, document number X27A-A-001-xx for details.





The tables below show those configuration settings important to the MC68K #1 and Generic #1 host bus interfaces.

Table 2-2: Summary of Power-On/Reset Options

S1D13705 Pin Name	value on this pin at the rising edge of RESET# is used to configure: (1/0)	
	0	1
CNF0	See Table 2-3: "Host Bus Interface Selection"	
CNF1		
CNF2		
CNF3	Little Endian	Big Endian

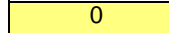
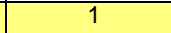
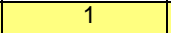
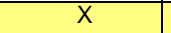
 = configuration for MC68328 support

Table 2-3: Host Bus Interface Selection

CNF2	CNF1	CNF0	BS#	Host Bus Interface
0	0	0	X	SH-4 interface
0	0	1	X	SH-3 interface
0	1	0	X	reserved
				MC68K #1, 16-bit
1	0	0	X	reserved
1	0	1	X	MC68K #2, 16-bit
1	1	0	0	reserved
1	1	0	1	reserved
				Generic #1, 16-bit
1	1	1	1	Generic #2, 16-bit

 = configuration for MC68328 using Generic #1 host bus interface

 = configuration for MC68328 using MC68K #1 host bus interface

## 2.4.3 MC68328 Chip Select Configuration

The S1D13705 requires a 128K byte address space for the display buffer and its internal registers. To accommodate this block size, it is preferable (but not required) to use one of the chip selects from groups A or B. Virtually any chip select other than CSA0 or CSD3 would be suitable for the S1D13705 interface.

In the example interface, chip select CSB3 is used to control the S1D13705. A 128K byte address space is used with the S1D13705 control registers mapped into the top 32 bytes of the 128K byte block and the 80K bytes of display buffer mapped to the starting address of the block. The chip select should have its RO (Read Only) bit set to 0, its BSW (Bus Data



---

Width) set to 1 for a 16-bit bus, and the WS (Wait states) bit should be set to 111b to allow the S1D13705 to terminate bus cycles externally. Enable  $\overline{DTACK}$  pin function with Register FFFFF433, Port G Select Register, bit 0.

## 3 Interfacing to the MC68EZ328

### 3.1 The MC68EZ328 System Bus

The MC68EZ328 is Motorola's second generation Dragonball microprocessor. The DragonballEZ is an integrated controller for handheld products, based upon the MC68EC000 microprocessor core. The DragonballEZ differs from its predecessor mainly in that it has increased speed, a DRAM controller, infrared communication, and an in-circuit emulator. The bus interface has also been simplified; it implements a 16-bit data bus and a 24-bit address bus. The bus interface is based on the standard MC68EC000 bus interface signals although the data bus byte lane control signals of the MC68EC000 bus interface ( $\overline{UDS}$  and  $\overline{LDS}$  - upper and lower data strobes) have been replaced by some new signals intended to simplify the task of interfacing to typical memory and peripheral devices.

The MC68EC000 bus control signals are well documented in Motorola's user manuals, and will not be described here. A brief summary of the new signals appears below:

- Output Enable ( $\overline{OE}$ ) is asserted when a read cycle is in process; it is intended to connect to the output enable control of a typical static RAM, EPROM, or Flash EPROM device.
- Upper Write Enable and Lower Write Enable ( $\overline{UWE}$  /  $\overline{LWE}$ ) are asserted during memory write cycles for the upper and lower bytes of the 16-bit data bus; they may be directly connected to the write enable inputs of a typical memory device.

The S1D13705 implements the MC68000 bus interface using its MC68K #1 mode but this mode requires the MC68EC000 control signals  $\overline{UDS}$  and  $\overline{LDS}$  so this mode cannot be used to connect the MC68EZ328 directly to the S1D13705. However, the Generic #1 interface mode on the S1D13705 is well suited to interface to the MC68EZ328.

### 3.2 Chip-Select Module

The MC68EZ328 can generate up to 8 chip select outputs, organized into four groups "A" through "D".

Each chip select group has a common base address register and address mask register, to set the base address and block size of the entire group. In addition, each chip select within a group has its own address compare and address mask register, to activate the chip select for a subset of the group's address block. Finally, each chip select may be individually programmed to control an 8 or 16-bit device, and each may be individually programmed to generate from 0 through 6 wait states internally, or allow the memory or peripheral device to terminate the cycle externally through use of the standard MC68000  $\overline{DTACK}$  signal.

Groups A and B are used to control ROM, SRAM, and Flash memory devices and have a block size of 128K bytes to 16M bytes. Chip select A0 is active immediately after reset and is a global chip-select so it is typically used to control a boot EPROM device. This chip

select ceases to decode globally once this chip-select's registers are programmed. Groups C and D are special in that they can also control DRAM interfaces. These last two groups have block size of 32K bytes to 4M bytes.

### 3.3 S1D13705 Host Bus Interface

This section is a summary of the host bus interface modes available on the S1D13705 that may be used to interface to the MC68EZ328.

The S1D13705 implements a 16-bit interface to the host microprocessor which may operate in one of several modes compatible with most of the popular embedded microprocessor families. The interface mode that may be used for the MC68EZ328 is:

- Generic #1 (Chip Select, plus individual Read Enable/Write Enable for each byte).

#### 3.3.1 Host Bus Pin Connection

The following table shows the functions of each host bus interface signal.

*Table 3-1: Host Bus Interface Pin Mapping*

<b>S1D13705 Pin Names</b>	<b>Generic #1</b>
AB[15:1]	A[15:1]
AB0	A0
DB[15:0]	D[15:0]
WE1#	WE1#
CS#	External Decode
BCLK	BCLK
BS#	connect to $V_{SS}$
RD/WR#	RD1#
RD#	RD0#
WE0#	WE0#
WAIT#	WAIT#
RESET#	RESET#

For details on configuration, refer to the *S1D13705 Hardware Functional Specification*, document number X27A-A-001-xx.

### 3.3.2 Generic #1 Interface Mode

Generic #1 interface mode is the most general and least processor-specific interface mode on the S1D13705. The Generic # 1 interface mode was chosen for this interface due to the simplicity of its timing.

The interface requires the following signals:

- BUSCLK is a clock input which is required by the S1D13705 host interface. It is separate from the input clock (CLKI) and is typically driven by the host CPU system clock.
- The address inputs AB0 through AB16, and the data bus DB0 through DB15, connect directly to the CPU address and data bus, respectively. On 32-bit big endian architectures such as the Power PC, the data bus would connect to the high-order data lines; on little endian hosts, or 16-bit big endian hosts, they would connect to the low-order data lines. The hardware engineer must ensure that CNF3 selects the proper endian mode upon reset.
- Chip Select (CS#) is driven by decoding the high-order address lines to select the proper register and memory address space.
- WE0# and WE1# are write enables for the low-order and high-order bytes, respectively, to be driven low when the host CPU is writing data to the S1D13705. These signals must be generated by external hardware based on the control outputs from the host CPU.
- RD# and RD/WR# are read enables for the low-order and high-order bytes, respectively, to be driven low when the host CPU is reading data from the S1D13705. These signals must be generated by external hardware based on the control outputs from the host CPU.
- WAIT# is a signal output from the S1D13705 that indicates the host CPU must wait until data is ready (read cycle) or accepted (write cycle) on the host bus. Since host CPU accesses to the S1D13705 may occur asynchronously to the display update, it is possible that contention may occur in accessing the S1D13705 internal registers and/or refresh memory. The WAIT# line resolves these contentions by forcing the host to wait until the resource arbitration is complete. This signal is active low and may need to be inverted if the host CPU wait state signal is active high.
- The Bus Status (BS#) signal is not used in the bus interface for Generic #1 mode. However, BS# is used to configure the S1D13705 for Generic #1 mode and should be tied low (connected to GND).

## 3.4 MC68EZ28 To S1D13705 Interface

### 3.4.1 Hardware Description

The interface between the MC68328 and the S1D13705 can be implemented using the Generic #1 host bus interface of the S1D13705.

The  $\overline{\text{DTACK}}$  signal must be made available for the S1D13705, since it inserts a variable number of wait states depending upon CPU/LCD synchronization and the LCD panel display mode.  $\overline{\text{WAIT\#}}$  must be inverted (using an inverter enabled by  $\text{CS\#}$ ) to make it an active high signal and thus compatible with the MC68EZ328 architecture. A single resistor is used to pull up  $\overline{\text{WAIT\#}}$  ( $\overline{\text{DTACK}}$ ) signal when terminating the bus cycle.

The following diagram shows a typical implementation of the MC68EZ328 to S1D13705 using the Generic #1 host bus interface. For further information on the Generic #1 host bus interface and AC Timing, refer to the *S1D13705 Hardware Functional Specification*, document number X27A-A-001-xx.

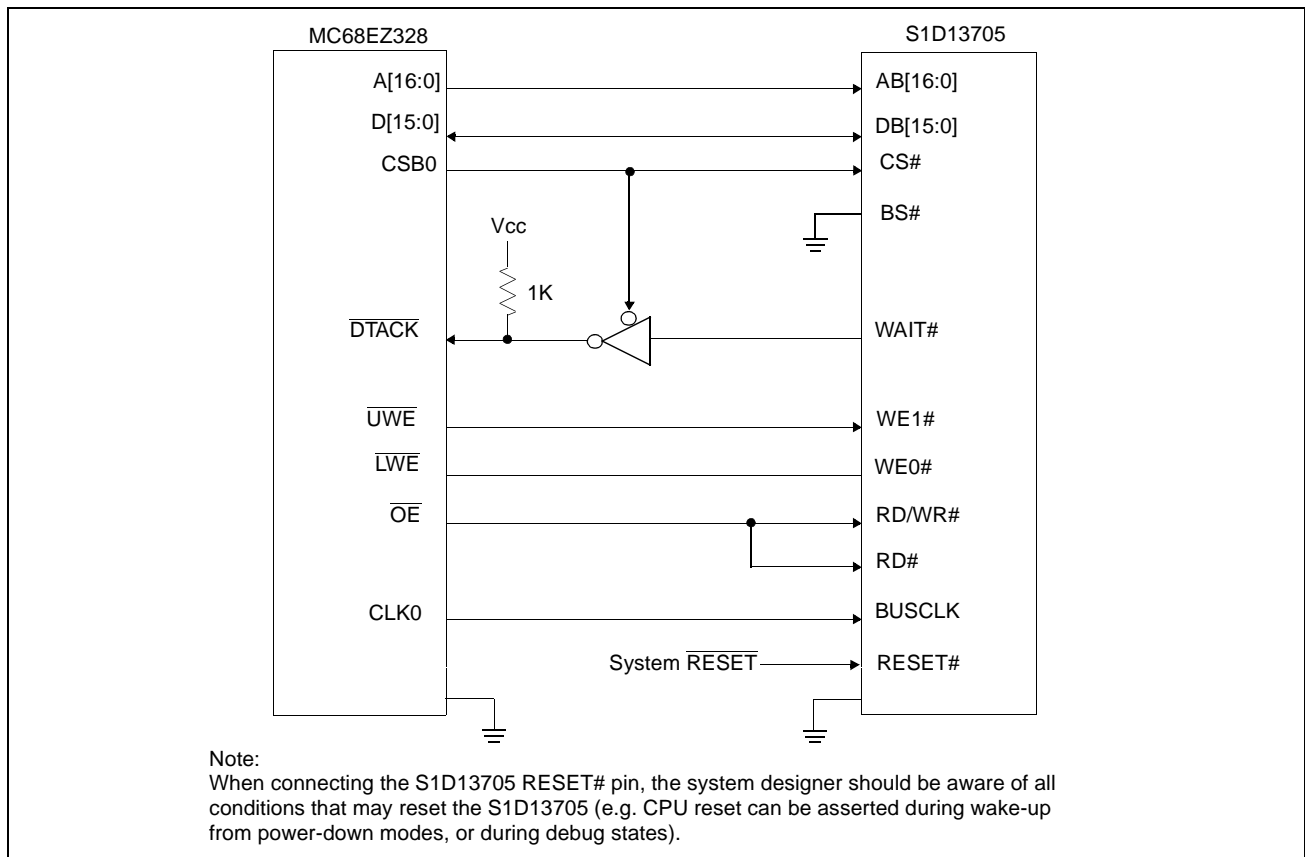

Figure 3-1: Typical Implementation of MC68EZ328 to S1D13705 Interface - Generic #1

### 3.4.2 S1D13705 Hardware Configuration

The S1D13705 uses CNF3 through CNF0 and BS# to allow selection of the bus mode and other configuration data on the rising edge of RESET#. Refer to the *S1D13705 Hardware Functional Specification*, document number X27A-A-001-xx for details.

The tables below show those configuration settings important to the Generic #1 host bus interface.

Table 3-2: Summary of Power-On/Reset Options

S1D13705 Pin Name	value on this pin at the rising edge of RESET# is used to configure: (1/0)	
	0	1
CNF0	See Table 2-3: "Host Bus Interface Selection"	
CNF1		
CNF2		
CNF3	Little Endian	Big Endian

 = configuration for MC68EZ328 support

Table 3-3: Host Bus Interface Selection

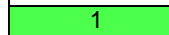
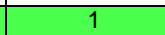
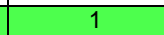
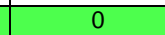
CNF2	CNF1	CNF0	BS#	Host Bus Interface
0	0	0	X	SH-4 interface
0	0	1	X	SH-3 interface
0	1	0	X	reserved
0	1	1	X	MC68K #1, 16-bit
1	0	0	X	reserved
1	0	1	X	MC68K #2, 16-bit
1	1	0	0	reserved
1	1	0	1	reserved
				Generic #1, 16-bit
1	1	1	1	Generic #2, 16-bit

 = configuration for MC68EZ328 using Generic #1 host bus interface

### 3.4.3 MC68EZ328 Chip Select Configuration

The S1D13705 requires a 128K byte address space for the display buffer and its internal registers. To accommodate this block size, it is preferable (but not required) to use one of the chip selects from groups A or B. Groups A and B can have a size range of 128K bytes to 16M bytes and groups C and D have a size range of 32K bytes to 16M bytes. Therefore, any chip select other than CSA0 would be suitable for the S1D13705 interface.

In the example interface, chip select CSB0 is used to control the S1D13705. A 128K byte address space is used with the S1D13705 control registers mapped into the top 32 bytes of the 128K byte block and the 80K bytes of display buffer mapped to the starting address of the block. The chip select should have its RO (Read Only) bit set to 0, its BSW (Bus Data

---

Width) set to 1 for a 16-bit bus, and the WS (Wait states) bit should be set to 111b to allow the S1D13705 to terminate bus cycles externally with  $\overline{DTACK}$ . Enable  $\overline{DTACK}$  pin function with Register FFFFF433, Port G Select Register, bit 0.

## 4 Interfacing to the MC68VZ328

### 4.1 The MC68VZ328 System Bus

The MC68VZ328 is Motorola's third generation Dragonball microprocessor. The DragonballVZ is an integrated controller for handheld products, based upon the FLX68000 microprocessor core with an external 24-bit address bus and 16-bit data bus. The DragonballVZ differs from its predecessor mainly in that it has increased speed, and support for SDRAM has been added to the DRAM controller. The bus interface consists of all the standard MC68000 bus interface signals except  $\overline{AS}$ , plus some new signals intended to simplify the task of interfacing to typical memory and peripheral devices. The 68000 signals are multiplexed with IrDA, SPI and LCD controller signals.

The MC68000 bus control signals are well documented in Motorola's user manuals, and will not be described here. A brief summary of the new signals appears below:

- Output Enable ( $\overline{OE}$ ) is asserted when a read cycle is in process; it is intended to connect to the output enable control of a typical static RAM, EPROM, or Flash EPROM device.
- Upper Write Enable and Lower Write Enable ( $\overline{UWE}$  /  $\overline{LWE}$ ) are asserted during memory write cycles for the upper and lower bytes of the 16-bit data bus; they may be directly connected to the write enable inputs of a typical memory device.

The S1D13705 implements the MC68000 bus interface using its MC68K #1 mode. This mode may be used to interface the S1D13705 to the DragonballVZ if external logic is used to generate  $\overline{AS}$ . The Generic #1 interface mode on the S1D13705 is also well suited to interface to the MC68VZ328.

### 4.2 Chip-Select Module

The MC68VZ328 can generate up to 8 chip select outputs, organized into four groups, "A" through "D".

Each chip select group has a common base address register and address mask register, to set the base address and block size of the entire group. In addition, each chip select within a group has its own address compare and address mask register, to activate the chip select for a subset of the group's address block. Finally, each chip select may be individually programmed to control an 8 or 16-bit device, and each may be individually programmed to generate from 0 through 6 wait states internally, or allow the memory or peripheral device to terminate the cycle externally through use of the standard MC68000  $\overline{DTACK}$  signal.

Groups A and B are used to control ROM, SRAM, and Flash memory devices and have a block size of 128K bytes to 16M bytes. Chip select A0 is active immediately after reset and is a global chip-select so it is typically used to control a boot EPROM device. This chip select ceases to decode globally once this chip-select's registers are programmed. Groups C and D are special in that they can also control DRAM interfaces. These last two groups have block size of 32K bytes to 4M bytes.



## 4.3 S1D13705 Host Bus Interface

This section is a summary of the host bus interface modes available on the S1D13705 that may be used to interface to the MC68VZ328.

The S1D13705 implements a 16-bit interface to the host microprocessor which may operate in one of several modes compatible with most of the popular embedded microprocessor families. The two interface modes that may be used for the MC68VZ328 are:

- Motorola MC68K #1 (using Upper Data Strobe / Lower Data Strobe).
- Generic #1 (Chip Select, plus individual Read Enable/Write Enable for each byte).

### 4.3.1 Host Bus Pin Connection

The following table shows the functions of each host bus interface signal.

*Table 4-1: Host Bus Interface Pin Mapping*

S1D13705 Pin Names	MC68K #1	Generic #1
AB[15:1]	A[15:1]	A[15:1]
AB0	$\overline{\text{LDS}}$	A0
DB[15:0]	D[15:0]	D[15:0]
WE1#	$\overline{\text{UDS}}$	WE1#
CS#	External Decode	External Decode
BCLK	CLK	BCLK
BS#	$\overline{\text{AS}}$	connect to $V_{SS}$
RD/WR#	$\overline{\text{R/W}}$	RD1#
RD#	connect to IO $V_{DD}$	RD0#
WE0#	connect to IO $V_{DD}$	WE0#
WAIT#	$\overline{\text{DTACK}}$	WAIT#
RESET#	RESET#	RESET#

For details on configuration, refer to the *S1D13705 Hardware Functional Specification*, document number X27A-A-001-xx.

### 4.3.2 Generic #1 Interface Mode

Generic #1 interface mode is the most general and least processor-specific interface mode on the S1D13705. The Generic # 1 interface mode was chosen for this interface due to the simplicity of its timing.

The interface requires the following signals:

- BUSCLK is a clock input which is required by the S1D13705 host interface. It is separate from the input clock (CLKI) and is typically driven by the host CPU system clock.
- The address inputs AB0 through AB16, and the data bus DB0 through DB15, connect directly to the CPU address and data bus, respectively. On 32-bit big endian architectures such as the Power PC, the data bus would connect to the high-order data lines; on little endian hosts, or 16-bit big endian hosts, they would connect to the low-order data lines. The hardware engineer must ensure that CNF3 selects the proper endian mode upon reset.
- Chip Select (CS#) is driven by decoding the high-order address lines to select the proper register and memory address space.
- WE0# and WE1# are write enables for the low-order and high-order bytes, respectively, to be driven low when the host CPU is writing data to the S1D13705. These signals must be generated by external hardware based on the control outputs from the host CPU.
- RD# and RD/WR# are read enables for the low-order and high-order bytes, respectively, to be driven low when the host CPU is reading data from the S1D13705. These signals must be generated by external hardware based on the control outputs from the host CPU.
- WAIT# is a signal output from the S1D13705 that indicates the host CPU must wait until data is ready (read cycle) or accepted (write cycle) on the host bus. Since host CPU accesses to the S1D13705 may occur asynchronously to the display update, it is possible that contention may occur in accessing the S1D13705 internal registers and/or refresh memory. The WAIT# line resolves these contentions by forcing the host to wait until the resource arbitration is complete. This signal is active low and may need to be inverted if the host CPU wait state signal is active high.
- The Bus Status (BS#) signal is not used in the bus interface for Generic #1 mode. However, BS# is used to configure the S1D13705 for Generic #1 mode and should be tied low (connected to GND).

### 4.3.3 MC68K #1 Interface Mode

The MC68K #1 Interface Mode can be used to interface to the MC68VZ328 microprocessor if the previously mentioned, multiplexed, bus signals will not be used for other purposes.

The interface requires the following signals:

- BUSCLK is a clock input which synchronizes transfers between the host CPU and the S1D13705. It is separate from the input clock (CLKI) and is typically driven by the host CPU system clock.
- The address inputs AB1 through AB16, and the data bus DB0 through DB15, connect directly to the CPU address and data bus, respectively. On 32-bit big endian architectures such as the Power PC, the data bus would connect to the high-order data lines; on little endian hosts, or 16-bit big endian hosts, they would connect to the low-order data lines. The hardware engineer must ensure that CNF3 selects the proper endian mode upon reset.
- Chip Select (CS#) is driven by decoding the high-order address lines to select the proper register and memory address space.
- A0 and WE1# are the enables for the low-order and high-order bytes, respectively, to be driven low when the host CPU is reading or writing data to the S1D13705.
- RD/WR# is the read/write signal that is driven low when the CPU writes to the S1D13705 and is driven high when the CPU is doing a read from the S1D13705.
- WAIT# is a signal which is output from the S1D13705 to the host CPU that indicates when data is ready (read cycle) or accepted (write cycle) on the host bus. Since host CPU accesses to the S1D13705 may occur asynchronously to the display update, it is possible that contention may occur in accessing the S1D13705 internal registers and/or refresh memory. The WAIT# line resolves these contentions by forcing the host to wait until the resource arbitration is complete.
- The Bus Status (BS#) signal indicates that the address on the address bus is valid.
- The WE0# and RD# signals is not used in the bus interface for MC68K #1 and must be tied high (tied to IO  $V_{DD}$ ).

## 4.4 MC68VZ328 To S1D13705 Interface

### 4.4.1 Hardware Description

The interface between the MC68VZ328 and the S1D13705 can be implemented using either the MC68K #1 or Generic #1 host bus interface of the S1D13705.

#### Using The MC68K #1 Host Bus Interface

The MC68VZ328 multiplexes dual functions on some of its bus control pins (specifically  $\overline{UDS}$ ,  $\overline{LDS}$ , and  $\overline{DTACK}$ ). In implementations where all of these pins are available for use as bus control pins, then the S1D13705 interface is a straightforward implementation of the “MC68K #1” host bus interface. Since  $\overline{AS}$  is not provided by the DragonballVZ, CSB1 is connected to BS# and indicates that a valid address is on the bus.

The following diagram shows a typical implementation of the MC68VZ328 to S1D13705 using the MC68K #1 host bus interface. For further information on the MC68K #1 host bus interface and AC Timing, refer to the *S1D13705 Hardware Functional Specification*, document number X27A-A-001-xx.

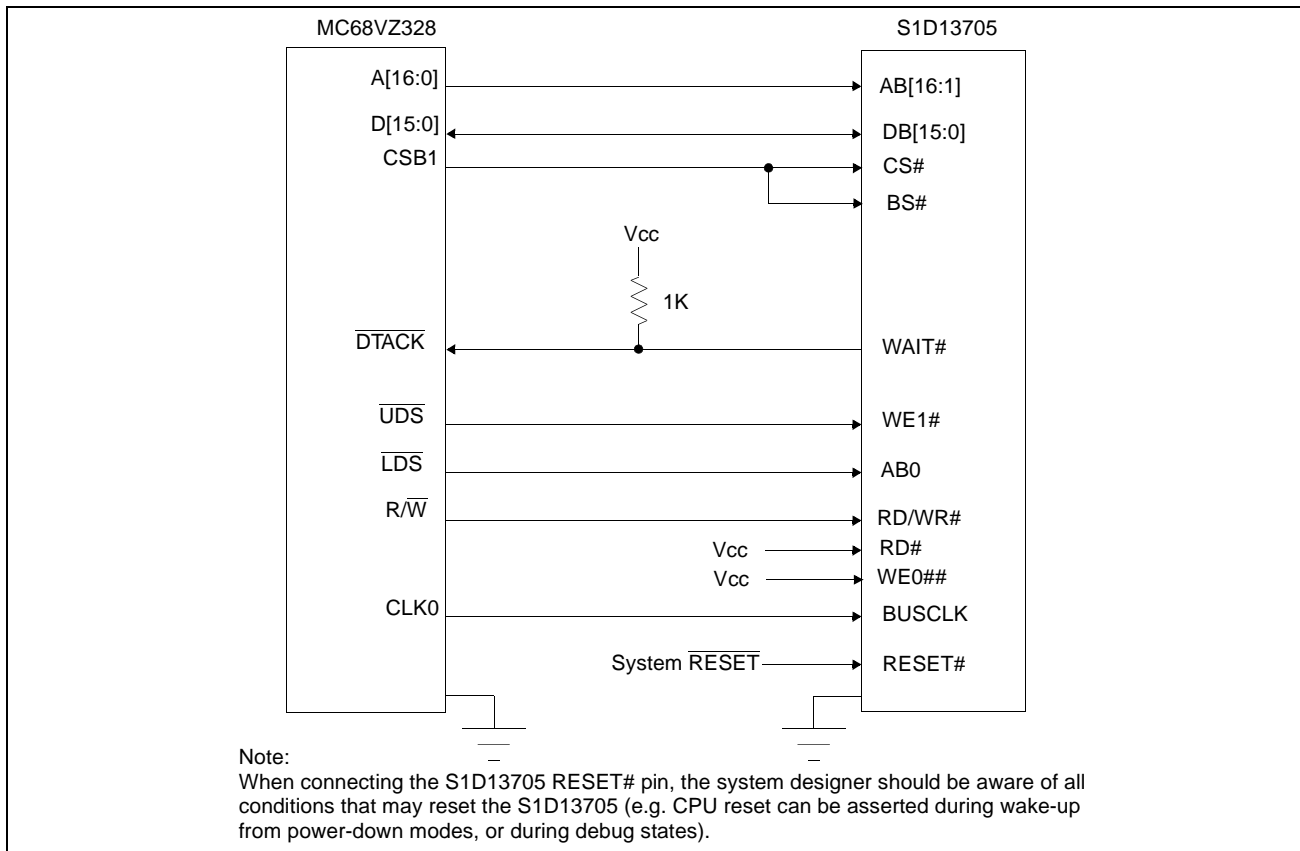

Figure 4-1: Typical Implementation of MC68VZ328 to S1D13705 Interface - MC68K #1

## Using The Generic #1 Host Bus Interface

The  $\overline{DTACK}$  signal must be made available for the S1D13705, since it inserts a variable number of wait states depending upon CPU/LCD synchronization and the LCD panel display mode.  $\overline{WAIT\#}$  must be inverted (using an inverter enabled by  $\overline{CS\#}$ ) to make it an active high signal and thus compatible with the MC68VZ328 architecture. A single resistor is used to pull up the  $\overline{WAIT\#}$  ( $\overline{DTACK}$ ) signal when terminating the bus cycle.

The following diagram shows a typical implementation of the MC68VZ328 to S1D13705 using the Generic #1 host bus interface. For further information on the Generic #1 host bus interface and AC Timing, refer to the *S1D13705 Hardware Functional Specification*, document number X27A-A-001-xx.

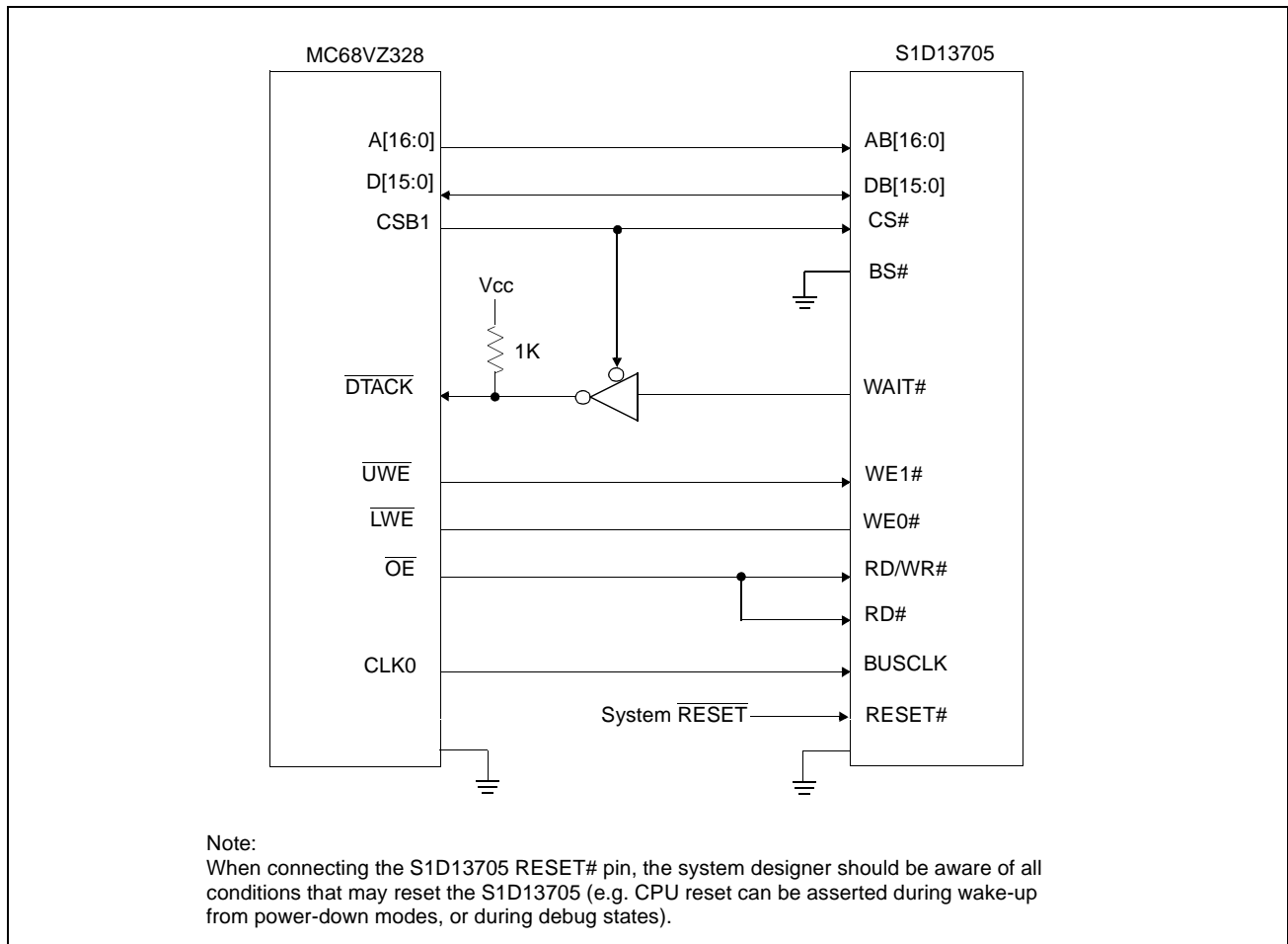

Figure 4-2: Typical Implementation of MC68VZ328 to S1D13705 Interface - Generic #1

## 4.4.2 S1D13705 Hardware Configuration

The S1D13705 uses CNF3 through CNF0 and BS# to allow selection of the bus mode and other configuration data on the rising edge of RESET#. Refer to the *S1D13705 Hardware Functional Specification*, document number X27A-A-001-xx for details.

The tables below show those configuration settings important to the MC68K #1 and Generic #1 host bus interfaces.

Table 4-2: Summary of Power-On/Reset Options

S1D13705 Pin Name	value on this pin at the rising edge of RESET# is used to configure: (1/0)	
	0	1
CNF0	See Table 2-3: "Host Bus Interface Selection"	
CNF1		
CNF2		
CNF3	Little Endian	Big Endian





 = configuration for MC68VZ328 support

Table 4-3: Host Bus Interface Selection

CNF2	CNF1	CNF0	BS#	Host Bus Interface
0	0	0	X	SH-4 interface
0	0	1	X	SH-3 interface
0	1	0	X	reserved
				MC68K #1, 16-bit
1	0	0	X	reserved
1	0	1	X	MC68K #2, 16-bit
1	1	0	0	reserved
1	1	0	1	reserved
				Generic #1, 16-bit
1	1	1	1	Generic #2, 16-bit

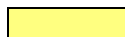
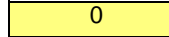
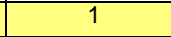
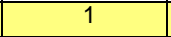
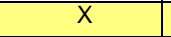
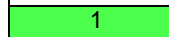
 = configuration for MC68VZ328 using Generic #1 host bus interface

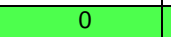
 = configuration for MC68VZ328 using MC68K #1 host bus interface

### 4.4.3 MC68VZ328 Chip Select and Pin Configuration

The S1D13705 requires a 128K byte address space for the display buffer and its internal registers. To accommodate this block size, it is preferable (but not required) to use one of the chip selects from groups A or B. Groups A and B can have a size range of 128K bytes to 16M bytes and groups C and D have a size range of 32K bytes to 16M bytes. Therefore, any chip select other than CSA0 would be suitable for the S1D13705 interface.

In the example interface, chip select CSB1 is used to control the S1D13705. A 128K byte address space is used with the S1D13705 control registers mapped into the top 32 bytes of the 128K byte block and the 80K bytes of display buffer mapped to the starting address of the block. The chip select should have its RO (Read Only) bit set to 0, its BSW (Bus Data Width) set to 1 for a 16-bit bus, and the WS (Wait states) bit should be set to 111b to allow the S1D13705 to terminate bus cycles externally with  $\overline{DTACK}$ . Enable  $\overline{DTACK}$  pin function with Register FFFFF433, Port G Select Register, bit 0.

Additional registers must be configured if the M68K #1 host bus interface is used.  $\overline{LDS}$ ,  $\overline{UDS}$  and  $R/\overline{W}$  must be enabled by setting register FFFFFFF443h bits 1, 2, and 3 to zero to enable the internal 68000 pin functions.

## 5 Software

Test utilities and Windows® CE display drivers are available for the S1D13705. Full source code is available for both the test utilities and the drivers.

The test utilities are configurable for different panel types using a program called 13705CFG, or by directly modifying the source. The Windows CE display drivers can be customized by the OEM for different panel types, resolutions and color depths only by modifying the source.

The S1D13705 test utilities and Windows CE display drivers are available from your sales support contact or on the internet at <http://www.eea.epson.com>.



## 6 References

### 6.1 Documents

- Motorola Inc., *MC68328 DragonBall® Integrated Microprocessor User's Manual*, Motorola Publication no. MC68328UM; available on the Internet at <http://www.mot.com/SPS/WIRELESS/products/MC68328.html>.
- Motorola Inc., *MC68EZ328 DragonBall-EZ® Integrated Processor User's Manual*, Motorola Publication no. MC68EZ328UM1; available on the Internet at <http://www.mot.com/SPS/WIRELESS/products/MC68EZ328.html>.
- Motorola Inc., *MC68VZ328 DragonBall-VZ® Integrated Processor User's Manual*, Motorola Publication no. MC683VZ28UM; available on the Internet at <http://www.mot.com/SPS/WIRELESS/products/MC68VZ328.html>.
- Epson Research and Development, Inc., *S1D13705 Hardware Functional Specification*; Document Number X27A-A-001-xx.
- Epson Research and Development, Inc., *S5U13705B00C Rev. 1.0 ISA Bus Evaluation Board User Manual*; Document Number X27A-G-005-xx.
- Epson Research and Development, Inc., *S1D13705 Programming Notes and Examples*; Document Number X27A-G-002-xx.

### 6.2 Document Sources

- Motorola Inc.: Motorola Literature Distribution Center, (800) 441-2447.
- Motorola Website: <http://www.mot.com>.
- Epson Electronics America website: <http://www.eea.epson.com>.

## 7 Technical Support

### 7.1 EPSON LCD Controllers (S1D13705)

**Japan**

Seiko Epson Corporation  
Electronic Devices Marketing Division  
421-8, Hino, Hino-shi  
Tokyo 191-8501, Japan  
Tel: 042-587-5812  
Fax: 042-587-5564  
<http://www.epson.co.jp>

**North America**

Epson Electronics America, Inc.  
150 River Oaks Parkway  
San Jose, CA 95134, USA  
Tel: (408) 922-0200  
Fax: (408) 922-0238  
<http://www.eea.epson.com>

**Taiwan**

Epson Taiwan Technology  
& Trading Ltd.  
10F, No. 287  
Nanking East Road  
Sec. 3, Taipei, Taiwan.  
Tel: 02-2717-7360  
Fax: 02-2712-9164

**Hong Kong**

Epson Hong Kong Ltd.  
20/F., Harbour Centre  
25 Harbour Road  
Wanchai, Hong Kong  
Tel: 2585-4600  
Fax: 2827-4346

**Europe**

Epson Europe Electronics GmbH  
Riesstrasse 15  
80992 Munich, Germany  
Tel: 089-14005-0  
Fax: 089-14005-110

**Singapore**

Epson Singapore Pte., Ltd.  
No. 1  
Temasek Avenue #36-00  
Millenia Tower  
Singapore, 039192  
Tel: 337-7911  
Fax: 334-2716

### 7.2 Motorola Dragonball Processors

- Motorola Design Line, (800) 521-6274.
- Local Motorola sales office or authorized distributor.

# EPSON®



## S1D13705 Embedded Memory LCD Controller

# Interfacing to the NEC VR4102/VR4111 Microprocessor

Document Number: X27A-G-008-02

Copyright © 2001 Epson Research and Development, Inc. All Rights Reserved.

Information in this document is subject to change without notice. You may download and use this document, but only for your own use in evaluating Seiko Epson/EPSON products. You may not modify the document. Epson Research and Development, Inc. disclaims any representation that the contents of this document are accurate or current. The Programs/Technologies described in this document may contain material protected under U.S. and/or International Patent laws.

EPSON is a registered trademark of Seiko Epson Corporation. All Trademarks are the property of their respective owners.

---

**THIS PAGE LEFT BLANK**

# Table of Contents

<b>1</b>	<b>Introduction</b>	<b>9</b>
<b>2</b>	<b>Interfacing to the NEC VR4102/VR4111</b>	<b>10</b>
2.1	The NEC VR4102/VR4111 System Bus	10
2.1.1	Overview	10
2.1.2	LCD Memory Access Cycles	11
<b>3</b>	<b>S1D13705 Host Bus Interface</b>	<b>12</b>
3.1	Host Bus Pin Connection	12
3.2	Generic #2 Interface Mode	13
<b>4</b>	<b>VR4102/VR4111 to S1D13705 Interface</b>	<b>14</b>
4.1	Hardware Description	14
4.2	S1D13705 Hardware Configuration	15
4.3	NEC VR4102/VR4111 Configuration	16
<b>5</b>	<b>Software</b>	<b>17</b>
<b>6</b>	<b>References</b>	<b>18</b>
6.1	Documents	18
6.2	Document Sources	18
<b>7</b>	<b>Technical Support</b>	<b>19</b>
7.1	Epson LCD Controllers (S1D13705)	19
7.2	NEC Electronics Inc.	19

**THIS PAGE LEFT BLANK**

---

## List of Tables

Table 3-1: Host Bus Interface Pin Mapping . . . . .	12
Table 4-1: Summary of Power-On/Reset Options . . . . .	15
Table 4-2: Host Bus Selection . . . . .	15

## List of Figures

Figure 2-1: NEC VR4102/VR4111 Read/Write Cycles . . . . .	11
Figure 4-1: Typical Implementation of VR4102/VR4111 to S1D13705 Interface . . . . .	14

**THIS PAGE LEFT BLANK**



# 1 Introduction

This application note describes the hardware required to interface the S1D13705 Embedded Memory LCD Controller and the NEC VR4102/VR4111 Microprocessor (*u*PD30102). The NEC VR4102/VR4111 Microprocessor is specifically designed to support an external LCD controller and the pairing of these two devices results in an embedded system offering impressive display capability with very low power consumption.

The designs described in this document are presented only as examples of how such interfaces might be implemented. This application note will be updated as appropriate. Please check the Epson Electronics America website at <http://www.eea.epson.com> for the latest revision of this document before beginning any development.

We appreciate your comments on our documentation. Please contact us via email at [techpubs@erd.epson.com](mailto:techpubs@erd.epson.com).

## 2 Interfacing to the NEC VR4102/VR4111

### 2.1 The NEC VR4102/VR4111 System Bus

The VR-Series family of microprocessors features a high-speed synchronous system bus typical of modern microprocessors. Designed with external LCD controller support and Windows CE-based embedded consumer applications in mind, the VR4102/VR4111 offers a highly integrated solution for portable systems. This section is an overview of the operation of the CPU bus to establish interface requirements.

#### 2.1.1 Overview

The NEC VR4102/VR4111 is designed around the RISC architecture developed by MIPS. This microprocessor is designed around the 66MHz VR4100 CPU core which supports 64-bit processing. The CPU communicates with the Bus Control Unit (BCU) with its internal SysAD bus. The BCU in turn communicates with external devices with its ADD and DAT buses that can be dynamically sized to 16 or 32-bit operation.

The NEC VR4102/VR4111 has direct support for an external LCD controller. Specific control signals are assigned for an external LCD controller that provide an easy interface to the CPU. A 16M byte block of memory is assigned for the LCD controller with its own chip select and ready signals available. Word or byte accesses are controlled by the system high byte signal, SHB#.

## 2.1.2 LCD Memory Access Cycles

Once an address in the LCD block of memory is placed on the external address bus, ADD[25:0], the LCD chip select, LCDCS#, is driven low. The read or write enable signals, RD# and WR#, are driven low for the appropriate cycle. LCDRDY is driven low by the S1D13705 to insert wait states into the cycle. The high byte enable is driven low for 16-bit transfers and high for 8-bit transfers.

Figure 2-1: “NEC VR4102/VR4111 Read/Write Cycles,” on page 9 shows the read and write cycles to the LCD Controller Interface.

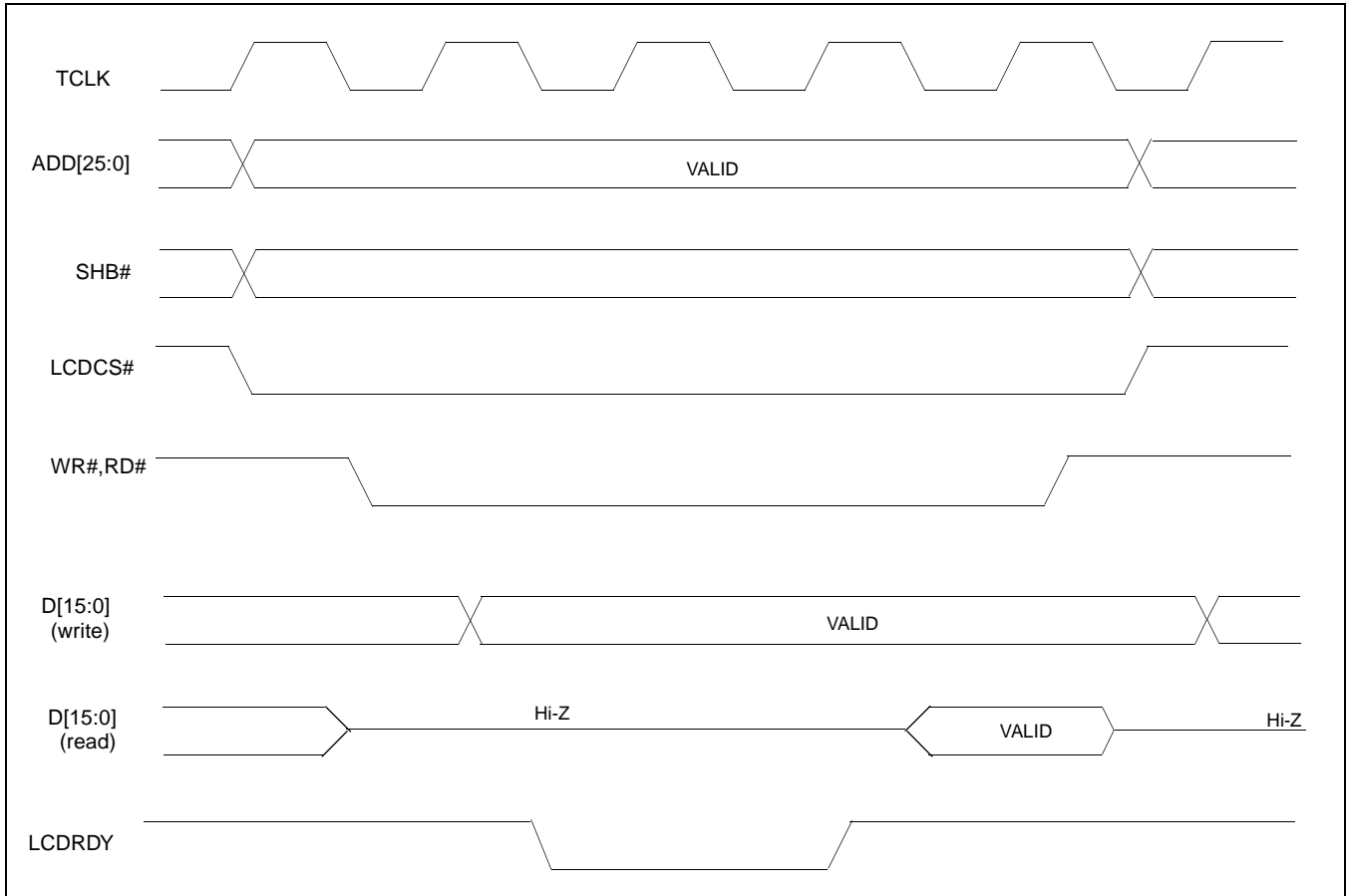

Figure 2-1: NEC VR4102/VR4111 Read/Write Cycles

## 3 S1D13705 Host Bus Interface

This section is a summary of the host bus interface modes available on the S1D13705 that would be used to interface to the VR4102/VR4111.

The S1D13705 implements a 16-bit interface to the host microprocessor which may operate in one of several modes compatible with most of the popular embedded microprocessor families. The interface mode used for the VR4102/VR4111 is:

- Generic #2 (External Chip Select, shared Read/Write Enable for high byte, individual Read/Write Enable for low byte).

### 3.1 Host Bus Pin Connection

The following table shows the functions of each host bus interface signal.

*Table 3-1: Host Bus Interface Pin Mapping*

S1D13705 Pin Names	Generic #2
AB[15:1]	A[15:1]
AB0	A0
DB[15:0]	D[15:0]
WE1#	BHE#
CS#	External Decode
BCLK	BCLK
BS#	connect to IO $V_{DD}$
RD/WR#	connect to IO $V_{DD}$
RD#	RD#
WE0#	WE#
WAIT#	WAIT#
RESET#	RESET#

For details on configuration, refer to the *S1D13705 Hardware Functional Specification*, document number X27A-A-001-xx.

## 3.2 Generic #2 Interface Mode

Generic #2 interface mode is a general and non-processor-specific interface mode on the S1D13705. The Generic # 2 interface mode was chosen for this interface due to the simplicity of its timing and compatibility with the VR4102/VR4111 control signals.

The interface requires the following signals:

- BUSCLK is a clock input which synchronizes transfers between the host CPU and the S1D13705. It is separate from the input clock (CLKI) and is typically driven by the host CPU system clock.
- The address inputs AB0 through AB16, and the data bus DB0 through DB15, connect directly to the CPU address and data bus, respectively. On 32-bit big endian architectures such as the Power PC, the data bus would connect to the high-order data lines; on little endian hosts, or 16-bit big endian hosts, they would connect to the low-order data lines. The hardware engineer must ensure that CNF3 selects the proper endian mode upon reset.
- Chip Select (CS#) is driven by decoding the high-order address lines to select the proper register and memory address space.
- WE1# is the high byte enable for both read and write cycles.
- WE0# is the write enable for the S1D13705, to be driven low when the host CPU is writing data to the S1D13705.
- RD# is the read enable for the S1D13705, to be driven low when the host CPU is reading data from the S1D13705.
- WAIT# is a signal which is output from the S1D13705 to the host CPU that indicates when data is ready (read cycle) or accepted (write cycle) on the host bus. Since host CPU accesses to the S1D13705 may occur asynchronously to the display update, it is possible that contention may occur in accessing the 13705 internal registers and/or refresh memory. The WAIT# line resolves these contentions by forcing the host to wait until the resource arbitration is complete. This signal is active low and may need to be inverted if the host CPU wait state signal is active high.
- The Bus Status (BS#) and Read/Write (RD/WR#) signals are not used in the bus interface for Generic #2 mode. However, BS# is used to configure the S1D13705 for Generic #2 mode and should be tied high (connected to IO V<sub>DD</sub>). RD/WR# should also be tied high.

## 4 VR4102/VR4111 to S1D13705 Interface

### 4.1 Hardware Description

The NEC VR4102/VR4111 Microprocessor is specifically designed to support an external LCD controller by providing the internal address decoding and control signals necessary. By using the Generic # 2 interface, no glue logic is required to interface the S1D13705 and the NEC VR4102/VR4111. A pull-up resistor is attached to WAIT# to speed up its rise time when terminating a cycle.

The following diagram shows a typical implementation of the VR4102/VR4111 to S1D13705 interface.

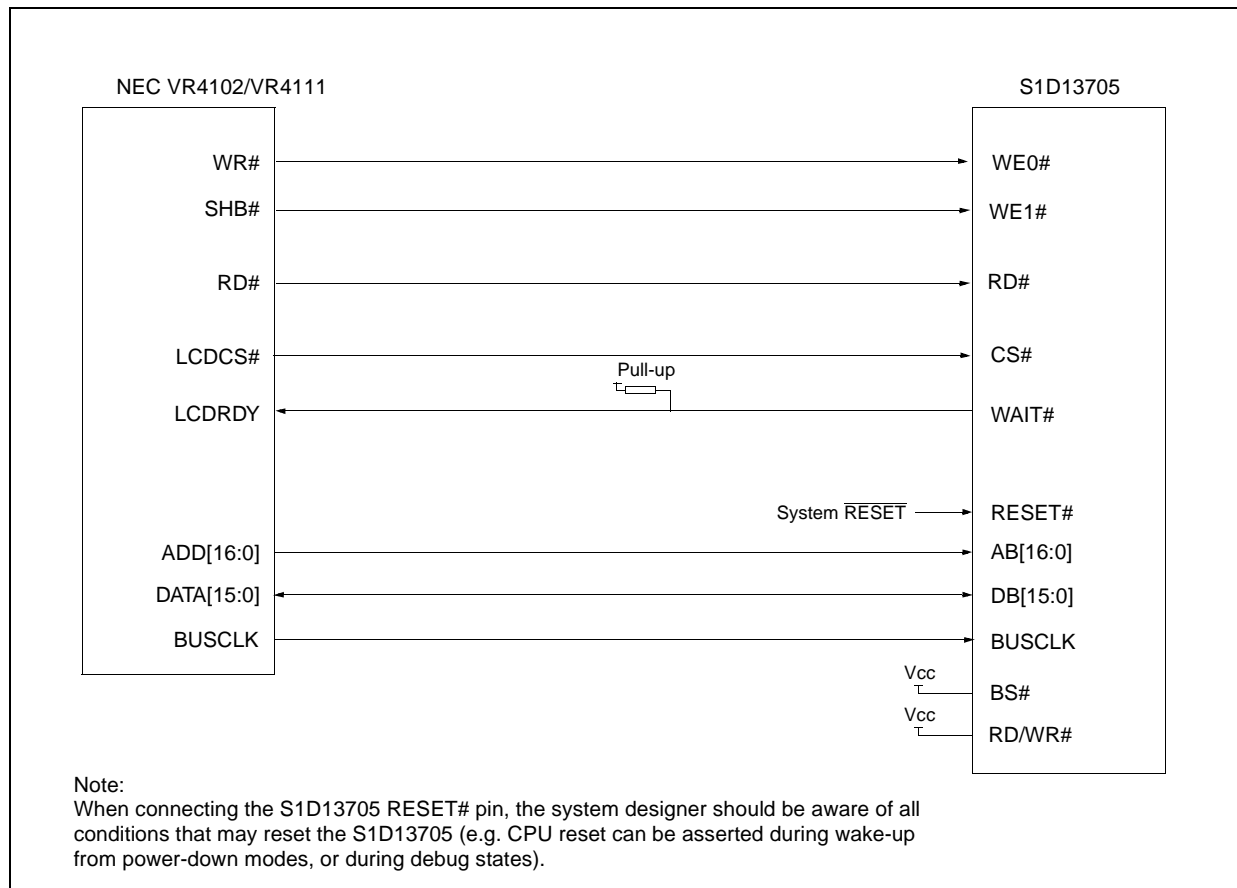

Figure 4-1: Typical Implementation of VR4102/VR4111 to S1D13705 Interface

## 4.2 S1D13705 Hardware Configuration

The S1D13705 uses CNF3 through CNF0 and BS# to allow selection of the bus mode and other configuration data on the rising edge of RESET#. Refer to the *S1D13705 Hardware Functional Specification*, document number X27A-A-001-xx for details.

The tables below show those configuration settings important to the Generic #2 host bus interface.

*Table 4-1: Summary of Power-On/Reset Options*

Signal	value on this pin at the rising edge of RESET# is used to configure: (0/1)	
	0	1
CNF0	See "Host Bus Selection" table below	See "Host Bus Selection" table below
CNF1		
CNF2		
CNF3	Little Endian	Big Endian

= configuration for NEC VR4102/VR4111 support

*Table 4-2: Host Bus Selection*

CNF2	CNF1	CNF0	BS#	Host Bus Interface
1	1	1	1	Generic #2, 16-bit

= configuration for NEC VR4102/VR4111 support

### 4.3 NEC VR4102/VR4111 Configuration

The NEC VR4102/VR4111 provides the internal address decoding necessary to map to an external LCD controller. Physical address 0A000000h to 0AFFFFFFh (16M bytes) is reserved for an external LCD controller.

The S1D13705 supports up to 80K bytes of display buffer memory and 32 bytes for internal registers. Therefore, the S1D13705 will be shadowed over the entire 16M byte memory range at 128K byte segments. The starting address of the display buffer is 0A000000h and register 0 of the S1D13705 (REG[00h]) resides at 0A01FFE0h.

The NEC VR4102/VR4111 has a 16-bit internal register named BCUCNTREG2 located at address 0B000002h. It must be set to the value of 0001h to indicate that LCD controller accesses use a non-inverting data bus.

The 16-bit internal register named BCUCNTREG1, located at address 0B000000h, must have bit D[13] (ISA/LCD bit) set to 0 to reserve the 16M bytes space, 0A000000h to 0AFFFFFFh, for LCD use and not as ISA bus memory space.



---

## 5 Software

Test utilities and Windows® CE v2.0 display drivers are available for the S1D13705. Full source code is available for both the test utilities and the drivers.

The test utilities are configurable for different panel types using a program called 13705CFG, or by directly modifying the source. The Windows CE v2.0 display drivers can be customized by the OEM for different panel types, resolutions and color depths only by modifying the source.

The S1D13705 test utilities and Windows CE v2.0 display drivers are available from your sales support contact or on the internet at <http://www.eea.epson.com>.

## 6 References

### 6.1 Documents

- NEC VR4102/VR4111 64/32-bit Microprocessor Preliminary User's Manual.
- Epson Research and Development, Inc., *S1D13705 Embedded Memory Color LCD Controller Hardware Functional Specification*; Document Number X27A-A-001-xx.
- Epson Research and Development, Inc., *S5U13705B00C Rev. 1.0 ISA Bus Evaluation Board User Manual*; Document Number X27A-G-005-xx.
- Epson Research and Development, Inc., *S1D13705 Programming Notes and Examples*; Document Number X27A-G-002-xx.

### 6.2 Document Sources

- NEC website: <http://www.nec.com>.
- Epson Electronics America website: <http://www.eea.epson.com>

## 7 Technical Support

### 7.1 Epson LCD Controllers (S1D13705)

#### Japan

Seiko Epson Corporation  
Electronic Devices Marketing Division  
421-8, Hino, Hino-shi  
Tokyo 191-8501, Japan  
Tel: 042-587-5812  
Fax: 042-587-5564  
<http://www.epson.co.jp>

#### North America

Epson Electronics America, Inc.  
150 River Oaks Parkway  
San Jose, CA 95134, USA  
Tel: (408) 922-0200  
Fax: (408) 922-0238  
<http://www.eea.epson.com>

#### Taiwan, R.O.C.

Epson Taiwan Technology  
& Trading Ltd.  
10F, No. 287  
Nanking East Road  
Sec. 3, Taipei, Taiwan, R.O.C.  
Tel: 02-2717-7360  
Fax: 02-2712-9164

#### Hong Kong

Epson Hong Kong Ltd.  
20/F., Harbour Centre  
25 Harbour Road  
Wanchai, Hong Kong  
Tel: 2585-4600  
Fax: 2827-4346

#### Europe

Epson Europe Electronics GmbH  
Riesstrasse 15  
80992 Munich, Germany  
Tel: 089-14005-0  
Fax: 089-14005-110

#### Singapore

Epson Singapore Pte., Ltd.  
No. 1  
Temasek Avenue #36-00  
Millenia Tower  
Singapore, 039192  
Tel: 337-7911  
Fax: 334-2716

### 7.2 NEC Electronics Inc.

#### NEC Electronics Inc. (U.S.A.)

Santa Clara  
California  
Tel: (800) 366-9782  
Fax: (800) 729-9288  
<http://www.nec.com>

**THIS PAGE LEFT BLANK**

# EPSON®



## S1D13705 Embedded Memory LCD Controller

# Interfacing to the PC Card Bus

Document Number: X27A-G-009-02

Copyright © 2001 Epson Research and Development, Inc. All Rights Reserved.

Information in this document is subject to change without notice. You may download and use this document, but only for your own use in evaluating Seiko Epson/EPSON products. You may not modify the document. Epson Research and Development, Inc. disclaims any representation that the contents of this document are accurate or current. The Programs/Technologies described in this document may contain material protected under U.S. and/or International Patent laws.

EPSON is a registered trademark of Seiko Epson Corporation. All other trademarks are the property of their respective owners.

---

**THIS PAGE LEFT BLANK**

# Table of Contents

<b>1</b>	<b>Introduction</b>	<b>7</b>
<b>2</b>	<b>Interfacing to the PC Card Bus</b>	<b>8</b>
2.1	The PC Card System Bus	8
2.1.1	PC Card Overview	8
2.1.2	Memory Access Cycles	8
<b>3</b>	<b>S1D13705 Bus Interface</b>	<b>10</b>
3.1	Host Bus Pin Connection	10
3.2	Generic #2 Interface Mode	11
<b>4</b>	<b>PC Card to S1D13705 Interface</b>	<b>12</b>
4.1	Hardware Connections	12
4.2	S1D13705 Hardware Configuration	13
4.3	Register/Memory Mapping	13
<b>5</b>	<b>Software</b>	<b>14</b>
<b>6</b>	<b>References</b>	<b>15</b>
6.1	Documents	15
6.2	Document Sources	15
<b>7</b>	<b>Technical Support</b>	<b>16</b>
7.1	EPSON LCD Controllers (S1D13705)	16
7.2	PC Card Standard	16

**THIS PAGE LEFT BLANK**



---

## List of Tables

Table 3-1: Host Bus Interface Pin Mapping . . . . .	10
Table 4-1: Summary of Power-On/Reset Options . . . . .	13
Table 4-2: Host Bus Interface Selection . . . . .	13

## List of Figures

Figure 2-1: PC Card Read Cycle . . . . .	9
Figure 2-2: PC Card Write Cycle . . . . .	9
Figure 4-1: Typical Implementation of PC Card to S1D13705 Interface. . . . .	12

**THIS PAGE LEFT BLANK**

---

# 1 Introduction

This application note describes the hardware and software environment required to interface the S1D13705 Embedded Memory LCD Controller and the PC Card (PCMCIA) bus.

The designs described in this document are presented only as examples of how such interfaces might be implemented. This application note will be updated as appropriate. Please check the Epson Electronics America website at <http://www.eea.epson.com> for the latest revision of this document before beginning any development.

We appreciate your comments on our documentation. Please contact us via email at [techpubs@erd.epson.com](mailto:techpubs@erd.epson.com).

## 2 Interfacing to the PC Card Bus

### 2.1 The PC Card System Bus

PC Card technology has gained wide acceptance in the mobile computing field as well as in other markets due to its portability and ruggedness. This section is an overview of the operation of the 16-bit PC Card interface conforming to the PCMCIA 2.0/JEIDA 4.1 Standard (or later).

#### 2.1.1 PC Card Overview

The 16-bit PC Card provides a 26-bit address bus and additional control lines which allow access to three 64M byte address ranges. These ranges are used for common memory space, IO space, and attribute memory space. Common memory may be accessed by a host system for memory read and write operations. Attribute memory is used for defining card specific information such as configuration registers, card capabilities, and card use. IO space maintains software and hardware compatibility with hosts such as the Intel x86 architecture, which address peripherals independently from memory space.

Bit notation follows the convention used by most microprocessors, the high bit is the most significant. Therefore, signals A25 and D15 are the most significant bits for the address and data bus respectively.

Support is provided for on-chip DMA controllers. To find further information on these topics, refer to Section 6, “References” on page 15.

PC Card bus signals are asynchronous to the host CPU bus signals. Bus cycles are started with the assertion of either the CE1# and/or the CE2# card enable signals. The cycle ends once these signals are de-asserted. Bus cycles can be lengthened using the WAIT# signal.

#### Note

The PCMCIA 2.0/JEIDA 4.1 (and later) PC Card Standard support the two signals WAIT# and RESET which are not supported in earlier versions of the standard. The WAIT# signal allows for asynchronous data transfers for memory, attribute, and IO access cycles. The RESET signal allows resetting of the card configuration by the reset line of the host CPU.

#### 2.1.2 Memory Access Cycles

A data transfer is initiated when the memory address is placed on the PC Card bus and one, or both, of the card enable signals (CE1# and CE2#) are driven low. REG# must be kept inactive. If only CE1# is driven low, 8-bit data transfers are enabled and A0 specifies whether the even or odd data byte appears on data bus lines D[7:0]. If both CE1# and CE2# are driven low, a 16-bit word transfer takes place. If only CE2# is driven low, an odd byte transfer occurs on data lines D[15:8].

During a read cycle, OE# (output enable) is driven low. A write cycle is specified by driving OE# high and driving the write enable signal (WE#) low. The cycle can be lengthened by driving WAIT# low for the time needed to complete the cycle.

Figure 2-1: and Figure 2-2: illustrate typical memory access cycles on the PC Card bus.

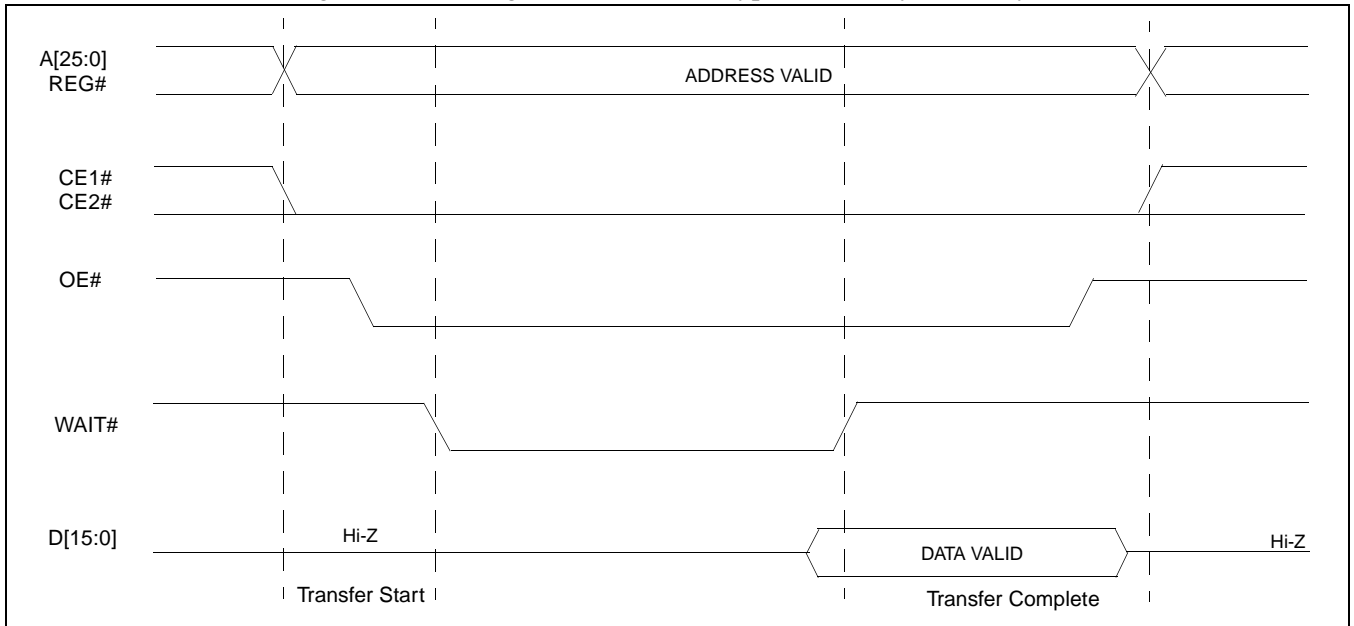

Figure 2-1: PC Card Read Cycle

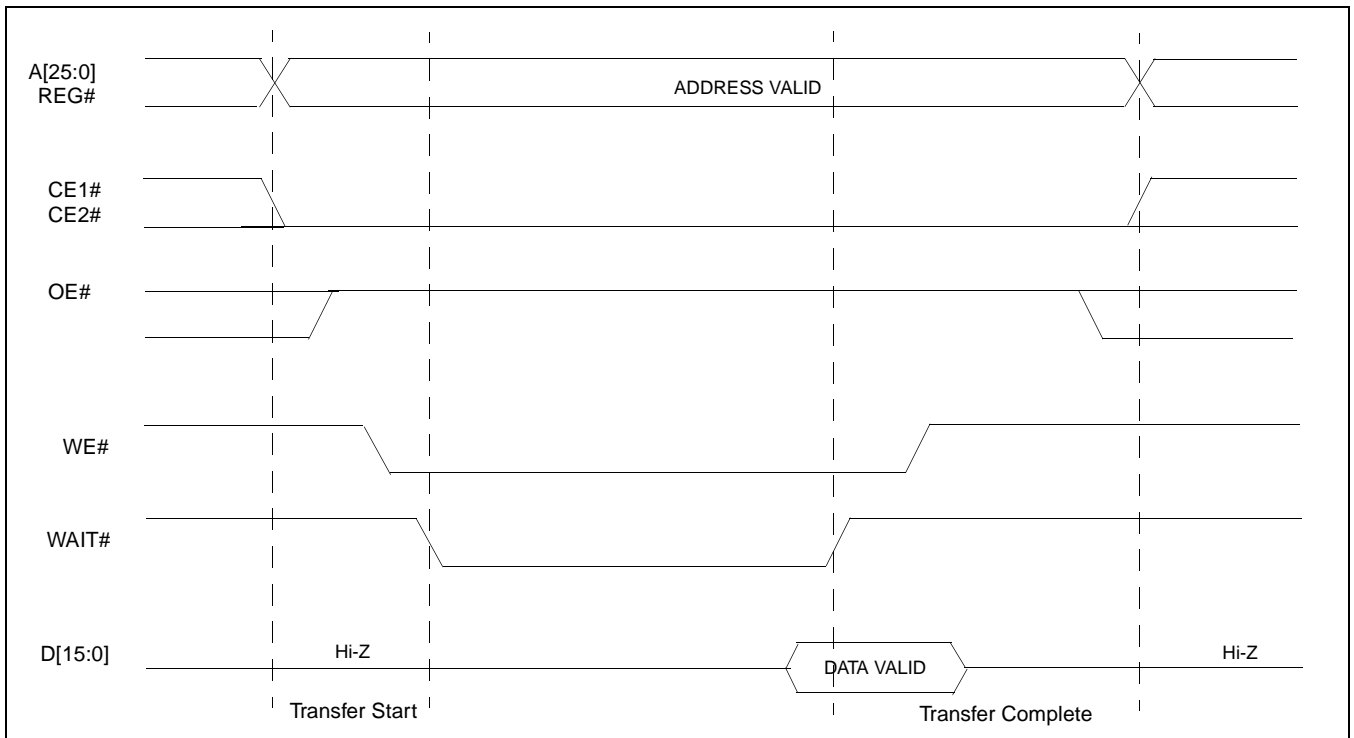

Figure 2-2: PC Card Write Cycle

## 3 S1D13705 Bus Interface

This section is a summary of the host bus interface modes available on the S1D13705 that would be used to interface to the PC Card bus.

The S1D13705 implements a 16-bit interface to the host microprocessor which may operate in one of several modes compatible with most of the popular embedded microprocessor families. The interface mode used for the PC Card bus is:

- Generic #2 (External Chip Select, shared Read/Write Enable for high byte, individual Read/Write Enable for low byte).

### 3.1 Host Bus Pin Connection

The following table shows the functions of the host bus interface signals.

*Table 3-1: Host Bus Interface Pin Mapping*

S1D13705 Pin Names	Generic #2
AB[15:1]	A[15:1]
AB0	A0
DB[15:0]	D[15:0]
WE1#	BHE#
CS#	External Decode
BCLK	BCLK
BS#	connect to IO $V_{DD}$
RD/WR#	connect to IO $V_{DD}$
RD#	RD#
WE0#	WE#
WAIT#	WAIT#
RESET#	RESET#

For details on configuration, refer to the *S1D13705 Hardware Functional Specification*, document number X27A-A-001-xx.

## 3.2 Generic #2 Interface Mode

Generic #2 interface mode is a general and non-processor-specific interface mode on the S1D13705. The Generic # 2 interface mode was chosen for this interface due to the simplicity of its timing and compatibility with the PC Card bus control signals.

The interface requires the following signals:

- BUSCLK is a clock input which synchronizes transfers between the host CPU and the S1D13705. It is separate from the input clock (CLKI) and is typically driven by the host CPU system clock.
- The address inputs AB0 through AB16, and the data bus DB0 through DB15, connect directly to the CPU address and data bus, respectively. On 32-bit big endian architectures such as the Power PC, the data bus would connect to the high-order data lines; on little endian hosts, or 16-bit big endian hosts, they would connect to the low-order data lines. The hardware engineer must ensure that CNF3 selects the proper endian mode upon reset.
- Chip Select (CS#) is driven by decoding the high-order address lines to select the proper register and memory address space.
- WE1# is the high byte enable for both read and write cycles.
- WE0# is the write enable for the S1D13705, to be driven low when the host CPU is writing data to the S1D13705.
- RD# is the read enable for the S1D13705, to be driven low when the host CPU is reading data from the S1D13705.
- WAIT# is a signal which is output from the S1D13705 to the host CPU that indicates when data is ready (read cycle) or accepted (write cycle) on the host bus. Since host CPU accesses to the S1D13705 may occur asynchronously to the display update, it is possible that contention may occur in accessing the 13705 internal registers and/or refresh memory. The WAIT# line resolves these contentions by forcing the host to wait until the resource arbitration is complete. This signal is active low and may need to be inverted if the host CPU wait state signal is active high.
- The Bus Status (BS#) and Read/Write (RD/WR#) signals are not used in the bus interface for Generic #2 mode. However, BS# is used to configure the S1D13705 for Generic #2 mode and should be tied high (connected to IO V<sub>DD</sub>). RD/WR# should also be tied high.

## 4 PC Card to S1D13705 Interface

### 4.1 Hardware Connections

The S1D13705 is interfaced to the PC Card bus with a minimal amount of glue logic. In this implementation, the address inputs (AB[16:0]) and data bus (DB[15:0]) connect directly to the CPU address (A[16:0]) and data bus (D[15:0]).

The PC Card interface does not provide a bus clock, so one must be supplied for the S1D13705. Since the bus clock frequency is not critical, nor does it have to be synchronous to the bus signals, it may be the same as CLKI.

BS# (bus start) is not used by Generic #2 mode but is used to configure the S1D13705 for either Generic #1 or Generic #2 bus and should be tied high (connected to IO  $V_{DD}$ ).

RD/WR# is also not used by Generic #2 bus and should be tied high (connected to IO  $V_{DD}$ ).

The following diagram shows a typical implementation of the PC Card to S1D13705 interface.

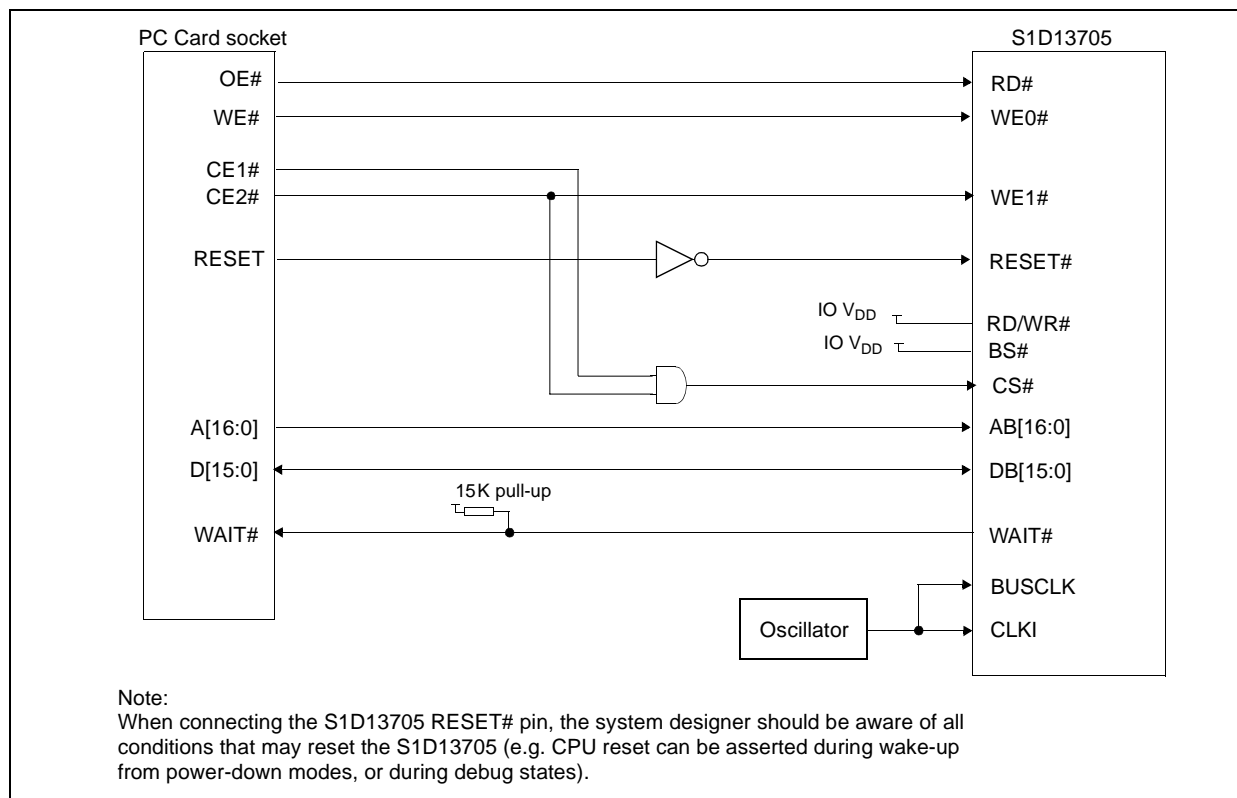

Figure 4-1: Typical Implementation of PC Card to S1D13705 Interface



## 4.2 S1D13705 Hardware Configuration

The S1D13705 uses CNF3 through CNF0 and BS# to allow selection of the bus mode and other configuration data on the rising edge of RESET#. Refer to the *S1D13705 Hardware Functional Specification*, document number X27A-A-001-xx for details.

The tables below show only those configuration settings important to the PC Card host bus interface.

*Table 4-1: Summary of Power-On/Reset Options*

Signal	Low	High
CNF0	See "Host Bus Selection" table below	See "Host Bus Selection" table below
CNF1		
CNF2		
CNF3	Little Endian	Big Endian

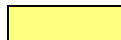
 = configuration for PC Card host bus interface

*Table 4-2: Host Bus Interface Selection*

CNF2	CNF1	CNF0	BS#	Host Bus Interface
1	1	1	1	Generic #2, 16-bit

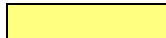
 = configuration for PC Card host bus interface

## 4.3 Register/Memory Mapping

The S1D13705 is a memory mapped device. The S1D13705 memory may be addressed starting at 0000h, or on consecutive 128K byte blocks, and its internal registers are located in the upper 32 bytes of the 128K byte block (i.e. REG[0] = 1FFE0h).

While the PC Card socket provides 64M bytes of memory address space, the S1D13705 only needs a 128K byte block of memory to accommodate its 80K byte display buffer and its 32 byte register set. For this reason only address bits A[16:0] are used while A[25:17] are ignored. Because the entire 64M bytes of memory is available, the S1D13705's memory and registers will be aliased every 128K bytes for a total of 512 times.

### Note

If aliasing is not desirable, the upper addresses must be fully decoded.

## 5 Software

Test utilities and Windows® CE v2.0 display drivers are available for the S1D13705. Full source code is available for both the test utilities and the drivers.

The test utilities are configurable for different panel types using a program called 13705CFG, or by directly modifying the source. The Windows CE v2.0 display drivers can be customized by the OEM for different panel types, resolutions and color depths only by modifying the source.

The S1D13705 test utilities and Windows CE v2.0 display drivers are available from your sales support contact or on the internet at <http://www.eea.epson.com>.

---

## 6 References

### 6.1 Documents

- PC Card (PCMCIA) Standard March 1997
- Epson Research and Development, Inc., *S1D13705 Embedded Memory Color LCD Controller Hardware Functional Specification*; Document Number X27A-A-001-xx.
- Epson Research and Development, Inc., *S5U13705B00C Rev. 1.0 ISA Bus Evaluation Board User Manual*; Document Number X27A-G-005-xx.
- Epson Research and Development, Inc., *S1D13705 Programming Notes and Examples*; Document Number X27A-G-002-xx.

### 6.2 Document Sources

- PC Card website: <http://www.pc-card.com>.
- Epson Electronics America website: <http://www.eea.epson.com>

## 7 Technical Support

### 7.1 EPSON LCD Controllers (S1D13705)

**Japan**

Seiko Epson Corporation  
Electronic Devices Marketing Division  
421-8, Hino, Hino-shi  
Tokyo 191-8501, Japan  
Tel: 042-587-5812  
Fax: 042-587-5564  
<http://www.epson.co.jp>

**North America**

Epson Electronics America, Inc.  
150 River Oaks Parkway  
San Jose, CA 95134, USA  
Tel: (408) 922-0200  
Fax: (408) 922-0238  
<http://www.eea.epson.com>

**Taiwan, R.O.C.**

Epson Taiwan Technology  
& Trading Ltd.  
10F, No. 287  
Nanking East Road  
Sec. 3, Taipei, Taiwan, R.O.C.  
Tel: 02-2717-7360  
Fax: 02-2712-9164

**Hong Kong**

Epson Hong Kong Ltd.  
20/F., Harbour Centre  
25 Harbour Road  
Wanchai, Hong Kong  
Tel: 2585-4600  
Fax: 2827-4346

**Europe**

Epson Europe Electronics GmbH  
Riesstrasse 15  
80992 Munich, Germany  
Tel: 089-14005-0  
Fax: 089-14005-110

**Singapore**

Epson Singapore Pte., Ltd.  
No. 1  
Temasek Avenue #36-00  
Millenia Tower  
Singapore, 039192  
Tel: 337-7911  
Fax: 334-2716

### 7.2 PC Card Standard

**PCMCIA**

**(Personal Computer Memory Card International Association)**

2635 North First Street, Suite 209  
San Jose, CA 95134  
Tel: (408) 433-2273  
Fax: (408) 433-9558  
<http://www.pc-card.com>

# EPSON®



## S1D13705 Embedded Memory LCD Controller

# Interfacing to the Motorola MPC821 Microprocessor

Document Number: X27A-G-010-02

Copyright © 2001 Epson Research and Development, Inc. All Rights Reserved.

Information in this document is subject to change without notice. You may download and use this document, but only for your own use in evaluating Seiko Epson/EPSON products. You may not modify the document. Epson Research and Development, Inc. disclaims any representation that the contents of this document are accurate or current. The Programs/Technologies described in this document may contain material protected under U.S. and/or International Patent laws.

EPSON is a registered trademark of Seiko Epson Corporation. All Trademarks are the property of their respective owners.

---

**THIS PAGE LEFT BLANK**

# Table of Contents

<b>1</b>	<b>Introduction</b>	<b>7</b>
<b>2</b>	<b>Interfacing to the MPC821</b>	<b>8</b>
2.1	The MPC8xx System Bus	8
2.2	MPC821 Bus Overview	8
2.2.1	Normal (Non-Burst) Bus Transactions	9
2.2.2	Burst Cycles	10
2.3	Memory Controller Module	11
2.3.1	General-Purpose Chip Select Module (GPCM)	11
2.3.2	User-Programmable Machine (UPM)	12
<b>3</b>	<b>S1D13705 Host Bus Interface</b>	<b>13</b>
3.1	Host Bus Interface Modes	13
3.2	Generic #1 Host Bus Interface Mode	14
<b>4</b>	<b>MPC821 to S1D13705 Interface</b>	<b>15</b>
4.1	Hardware Description	15
4.2	MPC821ADS Evaluation Board Hardware Connections	16
4.3	S1D13705 Hardware Configuration	18
4.4	MPC821 Chip Select Configuration	19
4.5	Test Software	20
<b>5</b>	<b>Software</b>	<b>22</b>
<b>6</b>	<b>References</b>	<b>23</b>
6.1	Documents	23
6.2	Document Sources	23
<b>7</b>	<b>Technical Support</b>	<b>24</b>
7.1	EPSON LCD/CRT Controllers (S1D13705)	24
7.2	Motorola MPC821 Processor	24

**THIS PAGE LEFT BLANK**



---

## List of Tables

Table 3-1: Host Bus Interface Pin Mapping . . . . .	13
Table 4-1: List of Connections from MPC821ADS to S1D13705 . . . . .	16
Table 4-2: Configuration Settings . . . . .	18
Table 4-3: Host Bus Selection . . . . .	18

## List of Figures

Figure 2-1: Power PC Memory Read Cycle . . . . .	9
Figure 2-2: Power PC Memory Write Cycle . . . . .	10
Figure 4-1: Typical Implementation of MPC821 to S1D13705 Interface . . . . .	15

**THIS PAGE LEFT BLANK**

---

# 1 Introduction

This application note describes the hardware and software environment required to interface the S1D13705 Embedded Memory LCD Controller and the Motorola MPC821 Processor.

The designs described in this document are presented only as examples of how such interfaces might be implemented. This application note will be updated as appropriate. Please check the Epson Electronics America website at <http://www.eea.epson.com> for the latest revision of this document before beginning any development.

We appreciate your comments on our documentation. Please contact us via email at [techpubs@erd.epson.com](mailto:techpubs@erd.epson.com).

## 2 Interfacing to the MPC821

### 2.1 The MPC8xx System Bus

The MPC8xx family of processors feature a high-speed synchronous system bus typical of modern RISC microprocessors. This section provides an overview of the operation of the CPU bus in order to establish interface requirements.

### 2.2 MPC821 Bus Overview

The MPC8xx microprocessor family uses a synchronous address and data bus. All IO is synchronous to a square-wave reference clock called MCLK (Master Clock). This clock runs at the machine cycle speed of the CPU core (typically 25 to 50 MHz). Most outputs from the processor change state on the rising edge of this clock. Similarly, most inputs to the processor are sampled on the rising edge.

#### Note

The external bus can run at one-half the CPU core speed using the clock control register. This is typically used when the CPU core is operated above 50 MHz.

The MPC821 can generate up to eight independent chip select outputs, each of which may be controlled by one of two types of timing generators: the General Purpose Chip Select Module (GPCM) or the User-Programmable Machine (UPM). Examples are given using the GPCM.

It should be noted that all Power PC microprocessors, including the MPC8xx family, use bit notation opposite from the convention used by most other microprocessor systems. Bit numbering for the MPC8xx always starts with zero as the most significant bit, and increments in value to the least-significant bit. For example, the most significant bits of the address bus and data bus are A0 and D0, while the least significant bits are A31 and D31.

The MPC8xx uses both a 32-bit address and data bus. A parity bit is supported for each of the four byte lanes on the data bus. Parity checking is done when data is read from external memory or peripherals, and generated by the MPC8xx bus controller on write cycles. All IO accesses are memory-mapped meaning there is no separate IO space in the Power PC architecture.

Support is provided for both on-chip (DMA controllers) and off-chip (other processors and peripheral controllers) bus masters. For further information on this topic, refer to Section 6, "References" on page 23.

The bus can support both normal and burst cycles. Burst memory cycles are used to fill on-chip cache memory, and for certain on-chip DMA operations. Normal cycles are used for all other data transfers.

## 2.2.1 Normal (Non-Burst) Bus Transactions

A data transfer is initiated by the bus master by placing the memory address on address lines A0 through A31 and driving  $\overline{TS}$  (Transfer Start) low for one clock cycle. Several control signals are also provided with the memory address:

- TSIZ[0:1] (Transfer Size) -- indicates whether the bus cycle is 8, 16, or 32-bit.
- $\text{RD}/\overline{\text{WR}}$  -- set high for read cycles and low for write cycles.
- AT[0:3] (Address Type Signals) -- provides more detail on the type of transfer being attempted.

When the peripheral device being accessed has completed the bus transfer, it asserts  $\overline{TA}$  (Transfer Acknowledge) for one clock cycle to complete the bus transaction. Once  $\overline{TA}$  has been asserted, the MPC821 will not start another bus cycle until  $\overline{TA}$  has been de-asserted. The minimum length of a bus transaction is two bus clocks.

Figure 2-1: “Power PC Memory Read Cycle” illustrates a typical memory read cycle on the Power PC system bus.

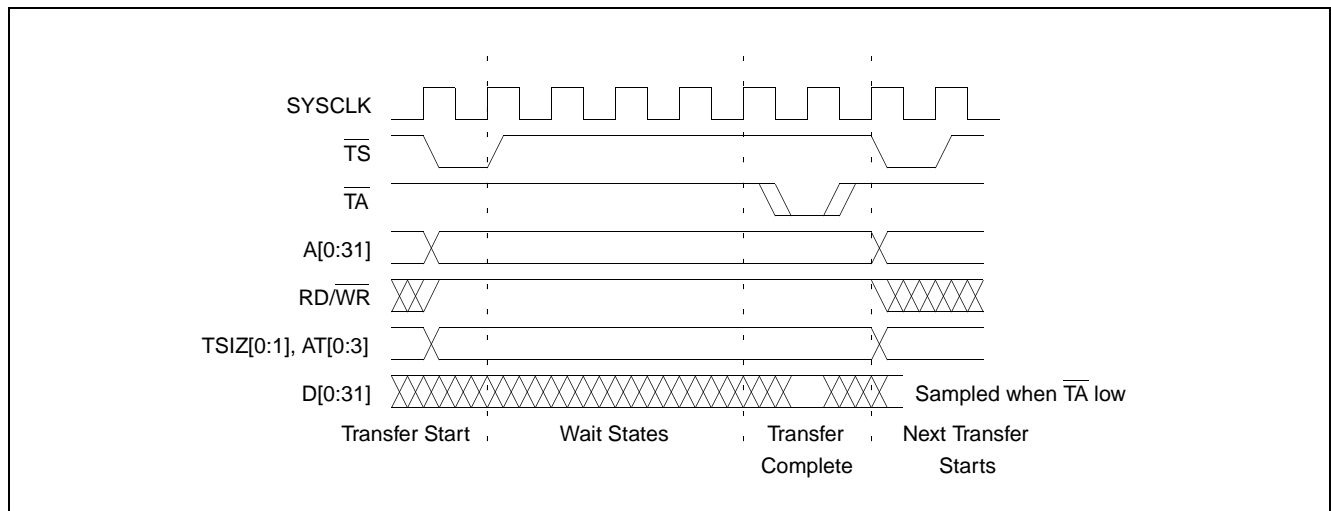

Figure 2-1: Power PC Memory Read Cycle

Figure 2-2: “Power PC Memory Write Cycle” illustrates a typical memory write cycle on the Power PC system bus.

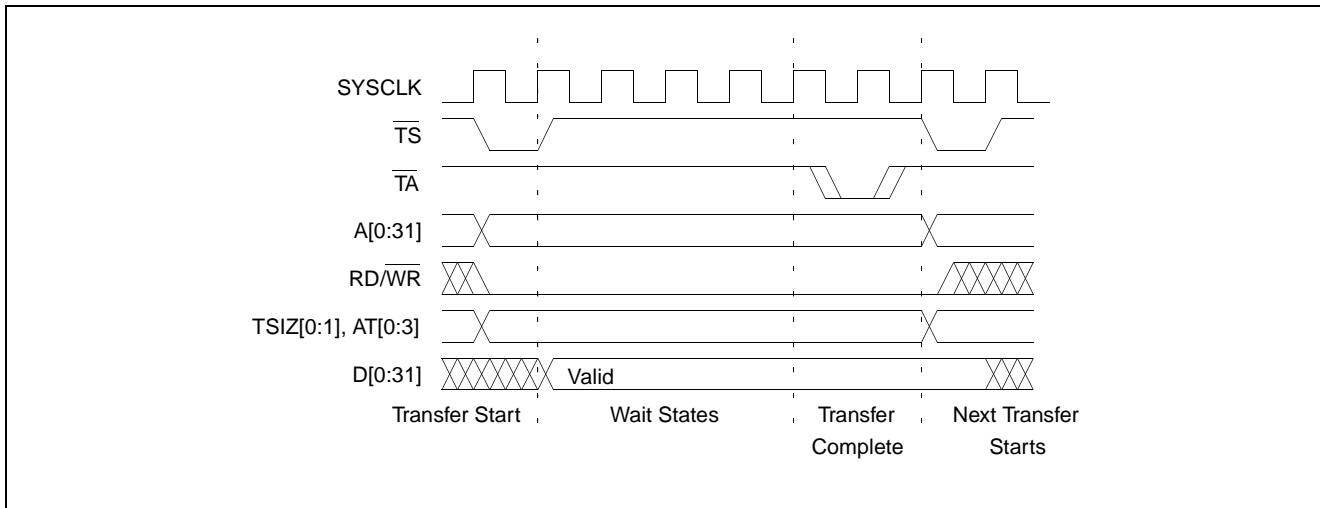

Figure 2-2: Power PC Memory Write Cycle

If an error occurs,  $\overline{TEA}$  (Transfer Error Acknowledge) is asserted and the bus cycle is aborted. For example, a peripheral device may assert  $\overline{TEA}$  if a parity error is detected, or the MPC821 bus controller may assert  $\overline{TEA}$  if no peripheral device responds at the addressed memory location within a bus time-out period.

For 32-bit transfers, all data lines (D[0:31]) are used and the two low-order address lines A30 and A31 are ignored. For 16-bit transfers, data lines D0 through D15 are used and address line A30 is ignored. For 8-bit transfers, data lines D0 through D7 are used and all address lines (A[0:31]) are used.

#### Note

This assumes that the Power PC core is operating in big endian mode (typically the case for embedded systems).

## 2.2.2 Burst Cycles

Burst memory cycles are used to fill on-chip cache memory and to carry out certain on-chip DMA operations. They are very similar to normal bus cycles with the following exceptions:

- Always 32-bit.
- Always attempt to transfer four 32-bit words sequentially.
- Always address longword-aligned memory (i.e. A30 and A31 are always 0:0).
- Do not increment address bits A28 and A29 between successive transfers; the addressed device must increment these address bits internally.

If a peripheral is not capable of supporting burst cycles, it can assert Burst Inhibit ( $\overline{\text{BI}}$ ) simultaneously with  $\overline{\text{TA}}$ , and the processor will revert to normal bus cycles for the remaining data transfers.

Burst cycles are mainly intended to facilitate cache line fills from program or data memory. They are normally not used for transfers to/from IO peripheral devices such as the S1D13705, therefore the interfaces described in this document do not attempt to support burst cycles. However, the example interfaces include circuitry to detect the assertion of  $\overline{\text{BDIP}}$  and respond with  $\overline{\text{BI}}$  if caching is accidentally enabled for the S1D13705 address space.

## 2.3 Memory Controller Module

### 2.3.1 General-Purpose Chip Select Module (GPCM)

The General-Purpose Chip Select Module (GPCM) is used to control memory and peripheral devices which do not require special timing or address multiplexing. In addition to the chip select output, it can generate active-low Output Enable ( $\overline{\text{OE}}$ ) and Write Enable ( $\overline{\text{WE}}$ ) signals compatible with most memory and x86-style peripherals. The MPC821 bus controller also provides a Read/Write ( $\text{RD}/\overline{\text{WR}}$ ) signal which is compatible with most 68K peripherals.

The GPCM is controlled by the values programmed into the Base Register (BR) and Option Register (OR) of the respective chip select. The Option Register sets the base address, the block size of the chip select, and controls the following timing parameters:

- The ACS bit field allows the chip select assertion to be delayed with respect to the address bus valid, by 0,  $\frac{1}{4}$ , or  $\frac{1}{2}$  clock cycle.
- The CSNT bit causes chip select and  $\overline{\text{WE}}$  to be negated  $\frac{1}{2}$  clock cycle earlier than normal.
- The TRLX (relaxed timing) bit will insert an additional one clock delay between assertion of the address bus and chip select. This accommodates memory and peripherals with long setup times.
- The EHTR (Extended hold time) bit will insert an additional 1-clock delay on the first access to a chip select.
- Up to 15 wait states may be inserted, or the peripheral can terminate the bus cycle itself by asserting  $\overline{\text{TA}}$  (Transfer Acknowledge).
- Any chip select may be programmed to assert  $\overline{\text{BI}}$  (Burst Inhibit) automatically when its memory space is addressed by the processor core.

### 2.3.2 User-Programmable Machine (UPM)

The UPM is typically used to control memory types, such as Dynamic RAMs, which have complex control or address multiplexing requirements. The UPM is a general purpose RAM-based pattern generator which can control address multiplexing, wait state generation, and five general-purpose output lines on the MPC821. Up to 64 pattern locations are available, each 32 bits wide. Separate patterns may be programmed for normal accesses, burst accesses, refresh (timer) events, and exception conditions. This flexibility allows almost any type of memory or peripheral device to be accommodated by the MPC821.

In this application note, the GPCM is used instead of the UPM, since the GPCM has enough flexibility to accommodate the S1D13705 and it is desirable to leave the UPM free to handle other interfacing duties, such as EDO DRAM.



## 3 S1D13705 Host Bus Interface

This section is a summary of the host bus interface mode used on the S1D13705 to interface to the MPC821.

The S1D13705 implements a 16-bit interface to the host microprocessor which may operate in one of several modes compatible with most of the popular embedded microprocessor families. The interface mode used for the MPC821 is:

- Generic #1 (Chip Select, plus individual Read Enable/Write Enable for each byte).

### 3.1 Host Bus Interface Modes

Table 3-1: Host Bus Interface Pin Mapping

S1D13705 Pin Names	Generic #1
AB[15:1]	A[15:1]
AB0	A0
DB[15:0]	D[15:0]
WE1#	WE1#
CS#	External Decode
BCLK	BCLK
BS#	connect to $V_{SS}$
RD/WR#	RD1#
RD#	RD0#
WE0#	WE0#
WAIT#	WAIT#
RESET#	RESET#

For details on configuration, refer to the *S1D13705 Hardware Functional Specification*, document number X27A-A-001-xx.

## 3.2 Generic #1 Host Bus Interface Mode

Generic #1 host bus interface mode is the most general and least processor-specific host bus interface mode on the S1D13705. The Generic # 1 host bus interface mode was chosen for this interface due to the simplicity of its timing.

The host bus interface requires the following signals:

- BUSCLK is a clock input which is required by the S1D13705 host interface. It is separate from the input clock (CLKI) and is typically driven by the host CPU system clock.
- The address inputs AB0 through AB16, and the data bus DB0 through DB15, connect directly to the CPU address and data bus, respectively. On 32-bit big endian architectures such as the Power PC, the data bus would connect to the high-order data lines; on little endian hosts, or 16-bit big endian hosts, they would connect to the low-order data lines. The hardware engineer must ensure that CNF3 selects the proper endian mode upon reset.
- Chip Select (CS#) is driven by decoding the high-order address lines to select the proper IO or memory address space.
- WE0# and WE1# are write enables for the low-order and high-order bytes, respectively, to be driven low when the host CPU is writing data to the S1D13705.
- RD# and RD/WR# are read enables for the low-order and high-order bytes, respectively, to be driven low when the host CPU is reading data from the S1D13705.
- WAIT# is a signal output from the S1D13705 that indicates the host CPU must wait until data is ready (read cycle) or accepted (write cycle) on the host bus. Since host CPU accesses to the S1D13705 may occur asynchronously to the display update, it is possible that contention may occur in accessing the S1D13705 internal registers and/or refresh memory. The WAIT# line resolves these contentions by forcing the host to wait until the resource arbitration is complete. This signal is active low and may need to be inverted if the host CPU wait state signal is active high.
- The Bus Status (BS#) signal is not used in the bus interface for Generic #1 mode. However, BS# is used to configure the S1D13705 for Generic #1 mode and should be tied low (connected to GND).

## 4 MPC821 to S1D13705 Interface

### 4.1 Hardware Description

The interface between the S1D13705 and the MPC821 requires minimal glue logic. One inverter is required to change the polarity of the WAIT# signal (an active low signal) to insert wait states in the bus cycle. The MPC821 Transfer Acknowledge signal ( $\overline{TA}$ ) is an active low signal which ends the current bus cycle. The inverter is enabled using CS# so that  $\overline{TA}$  is not driven by the S1D13705 during non-S1D13705 bus cycles. A single resistor is used to speed up the rise time of the WAIT# ( $\overline{TA}$ ) signal when terminating the bus cycle.

BS# (bus start) is not used in this implementation and should be tied low (connected to GND).

The following diagram shows a typical implementation of the MPC821 to S1D13705 interface.

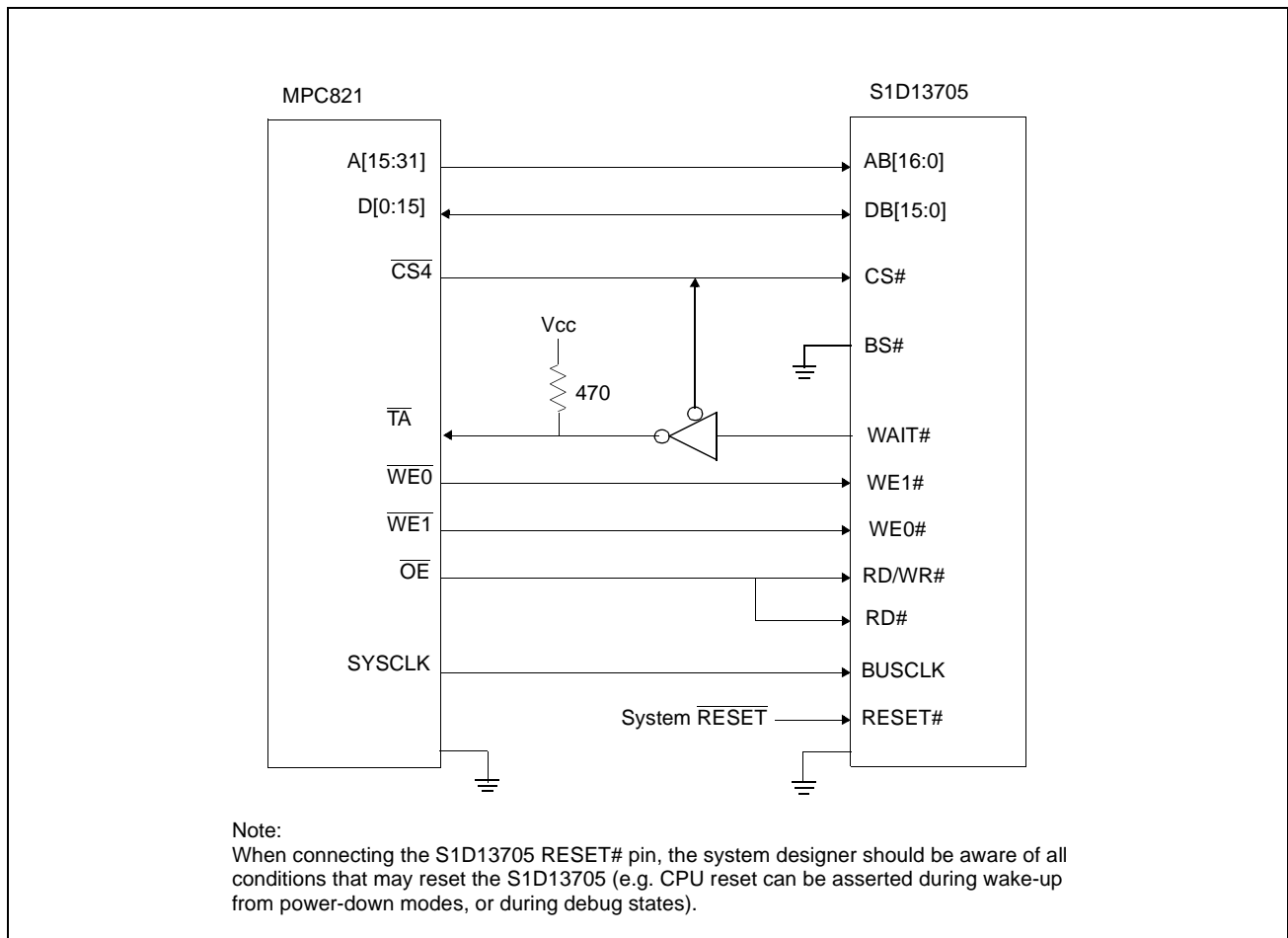

Figure 4-1: Typical Implementation of MPC821 to S1D13705 Interface

## 4.2 MPC821ADS Evaluation Board Hardware Connections

The following table details the connections between the pins and signals of the MPC821 and the S1D13705.

*Table 4-1: List of Connections from MPC821ADS to S1D13705*

MPC821 Signal Name	MPC821ADS Connector and Pin Name	S1D13705 Signal Name
Vcc	P6-A1, P6-B1	Vcc
A15	P6-D20	A16
A16	P6-B24	A15
A17	P6-C24	A14
A18	P6-D23	A13
A19	P6-D22	A12
A20	P6-D19	A11
A21	P6-A19	A10
A22	P6-D28	A9
A23	P6-A28	A8
A24	P6-C27	A7
A25	P6-A26	A6
A26	P6-C26	A5
A27	P6-A25	A4
A28	P6-D26	A3
A29	P6-B25	A2
A30	P6-B19	A1
A31	P6-D17	A0
D0	P12-A9	D15
D1	P12-C9	D14
D2	P12-D9	D13
D3	P12-A8	D12
D4	P12-B8	D11
D5	P12-D8	D10
D6	P12-B7	D9
D7	P12-C7	D8
D8	P12-A15	D7
D9	P12-C15	D6
D10	P12-D15	D5
D11	P12-A14	D4
D12	P12-B14	D3
D13	P12-D14	D2
D14	P12-B13	D1
D15	P12-C13	D0
SRESET	P9-D15	RESET#
SYSCLK	P9-C2	BUSCLK

*Table 4-1: List of Connections from MPC821ADS to S1D13705 (Continued)*

<b>MPC821 Signal Name</b>	<b>MPC821ADS Connector and Pin Name</b>	<b>S1D13705 Signal Name</b>
CS4	P6-D13	CS#
TA	P6-B6 to inverter enabled by CS#	WAIT#
WE0	P6-B15	WE1#
WE1	P6-A14	WE0#
OE	P6-B16	RD/WR#, RD#
GND	P12-A1, P12-B1, P12-A2, P12-B2, P12-A3, P12-B3, P12-A4, P12-B4, P12-A5, P12-B5, P12-A6, P12-B6, P12-A7	Vss

**Note**

The bit numbering of the Power PC bus signals is reversed from the normal convention, e.g.: the most significant address bit is A0, the next is A1, A2, etc.

## 4.3 S1D13705 Hardware Configuration

The S1D13705 uses CNF3 through CNF0 and BS# to allow selection of the bus mode and other configuration data on the rising edge of RESET#. Refer to the *S1D13705 Hardware Functional Specification*, document number X27A-A-001-xx for details.

The tables below show only those configuration settings important to the MPC821 interface. The settings are very similar to the ISA bus with the following exceptions:

- the WAIT# signal is active high rather than active low.
- the Power PC is big endian rather than little endian.

*Table 4-2: Configuration Settings*

Signal	Low	High
CNF0	See "Host Bus Selection" table below	See "Host Bus Selection" table below
CNF1		
CNF2		
CNF3	Little Endian	Big Endian
	= configuration for MPC821 host bus interface	

*Table 4-3: Host Bus Selection*

CNF2	CNF1	CNF0	BS#	Host Bus Interface
1	1	1	0	Generic #1, 16-bit
	= configuration for MPC821 host bus interface			

## 4.4 MPC821 Chip Select Configuration

The DRAM on the MPC821 ADS board extends from address 0 through 3F FFFFh, so the S1D13705 is addressed starting at 40 0000h. The S1D13705 uses a 128K byte segment of memory starting at this address, with the first 80K bytes used for the display buffer and the upper 32 bytes of this memory block used for the S1D13705 internal registers.

Chip select 4 is used to control the S1D13705. The following options are selected in the base address register (BR4):

- BA (0:16) = 0000 0000 0100 0000 0 – set starting address of S1D13705 to 40 0000h
- AT (0:2) = 0 – ignore address type bits
- PS (0:1) = 1:0 – memory port size is 16 bits
- PARE = 0 – disable parity checking
- WP = 0 – disable write protect
- MS (0:1) = 0:0 – select General Purpose Chip Select module to control this chip select
- V = 1 – set valid bit to enable chip select

The following options were selected in the option register (OR4):

- AM (0:16) = 1111 1111 1100 0000 0 – mask all but upper 10 address bits; S1D13705 consumes 4M byte of address space
- ATM (0:2) = 0 – ignore address type bits
- CSNT = 0 – normal  $\overline{CS}/\overline{WE}$  negation
- ACS (0:1) = 1:1 – delay  $\overline{CS}$  assertion by  $\frac{1}{2}$  clock cycle from address lines
- BI = 1 – assert Burst Inhibit
- SCY (0:3) = 0 – wait state selection; this field is ignored since external transfer acknowledge is used; see SETA below
- SETA = 1 – the S1D13705 generates an external transfer acknowledge using the WAIT# line
- TRLX = 0 – normal timing
- EHTR = 0 – normal timing

## 4.5 Test Software

The test software to exercise this interface is very simple. It configures chip select 4 on the MPC821 to map the S1D13705 to an unused 128k byte block of address space and loads the appropriate values into the option register for CS4. At that point the software runs in a tight loop reading the 13705 Revision Code Register REG[00h], which allows monitoring of the bus timing on a logic analyzer.

The source code for this test routine is as follows:

```
BR4      equ      $120          ; CS4 base register
OR4      equ      $124          ; CS4 option register
MemStart equ      $40           ; upper word of S1D13705 start address
RevCodeReg equ     1FFE0        ; address of Revision Code Register

Start    mfspr     r1,IMMR      ; get base address of internal registers
         andis.   r1,r1,$ffff   ; clear lower 16 bits to 0
         andis.   r2,r0,0       ; clear r2
         oris    r2,r2,MemStart ; write base address
         ori     r2,r2,$0801    ; port size 16 bits; select GPCM; enable
         stw    r2,BR4(r1)     ; write value to base register
         andis.   r2,r0,0       ; clear r2
         oris    r2,r2,$ffc0    ; address mask - use upper 10 bits
         ori     r2,r2,$0708    ; normal CS negation; delay CS ½ clock;
                                ; inhibit burst
         stw    r2,OR4(r1)     ; write to option register
         andis.   r1,r0,0       ; clear r1
         oris    r1,r1,MemStart ; point r1 to start of S1D13705 mem space
Loop     lbz     r0,RevCodeReg(r1) ; read revision code into r1
         b       Loop          ; branch forever

end
```



This code was entered into the memory of the MPC821ADS using the line-by-line assembler in MPC8BUG, the debugger provided with the ADS board. It was executed on the ADS and a logic analyzer was used to verify operation of the interface hardware.

**Note**

MPC8BUG does not support comments or symbolic equates; these have been added for clarity.

It is important to note that when the MPC821 comes out of reset, its on-chip caches and MMU are disabled. If the data cache is enabled, then the MMU must be set up so that the S1D13705 memory block is tagged as non-cacheable, to ensure that accesses to the S1D13705 will occur in proper order, and also to ensure that the MPC821 does not attempt to cache any data read from or written to the S1D13705 or its display buffer.

## 5 Software

Test utilities and Windows® CE v2.0 display drivers are available for the S1D13705. Full source code is available for both the test utilities and the drivers.

The test utilities are configurable for different panel types using a program called 13705CFG, or by directly modifying the source. The Windows CE v2.0 display drivers can be customized by the OEM for different panel types, resolutions and color depths only by modifying the source.

The S1D13705 test utilities and Windows CE v2.0 display drivers are available from your sales support contact or on the internet at <http://www.eea.epson.com>.

---

## 6 References

### 6.1 Documents

- Motorola Inc., *Power PC MPC821 Portable Systems Microprocessor User's Manual*, Motorola Publication no. MPC821UM/AD; available on the Internet at [http://www.mot.com/SPS/ADC/ppps/\\_subpgs/\\_documentation/821/821UM.html](http://www.mot.com/SPS/ADC/ppps/_subpgs/_documentation/821/821UM.html).
- Epson Research and Development, Inc., *S1D13705 Embedded Memory LCD Controller Hardware Functional Specification*; Document Number X27A-A-002-xx.
- Epson Research and Development, Inc., *S5U13705B00C Rev. 1.0 ISA Bus Evaluation Board User Manual*; Document Number X27A-G-005-xx.
- Epson Research and Development, Inc., *Programming Notes and Examples*; Document Number X27A-G-002-xx.

### 6.2 Document Sources

- Motorola Inc. Literature Distribution Center: (800) 441-2447.
- Motorola Inc. Website: <http://www.mot.com>.
- Epson Electronics America website: <http://www.eea.epson.com>.

## 7 Technical Support

### 7.1 EPSON LCD/CRT Controllers (S1D13705)

**Japan**

Seiko Epson Corporation  
Electronic Devices Marketing Division  
421-8, Hino, Hino-shi  
Tokyo 191-8501, Japan  
Tel: 042-587-5812  
Fax: 042-587-5564  
<http://www.epson.co.jp>

**North America**

Epson Electronics America, Inc.  
150 River Oaks Parkway  
San Jose, CA 95134, USA  
Tel: (408) 922-0200  
Fax: (408) 922-0238  
<http://www.eea.epson.com>

**Taiwan, R.O.C.**

Epson Taiwan Technology  
& Trading Ltd.  
10F, No. 287  
Nanking East Road  
Sec. 3, Taipei, Taiwan, R.O.C.  
Tel: 02-2717-7360  
Fax: 02-2712-9164

**Hong Kong**

Epson Hong Kong Ltd.  
20/F., Harbour Centre  
25 Harbour Road  
Wanchai, Hong Kong  
Tel: 2585-4600  
Fax: 2827-4346

**Europe**

Epson Europe Electronics GmbH  
Riesstrasse 15  
80992 Munich, Germany  
Tel: 089-14005-0  
Fax: 089-14005-110

**Singapore**

Epson Singapore Pte., Ltd.  
No. 1  
Temasek Avenue #36-00  
Millenia Tower  
Singapore, 039192  
Tel: 337-7911  
Fax: 334-2716

### 7.2 Motorola MPC821 Processor

- Motorola Design Line, (800) 521-6274.
- Local Motorola sales office or authorized distributor.

# EPSON®



## S1D13705 Embedded Memory LCD Controller

# Interfacing to the Motorola MCF5307 "ColdFire" Microprocessor

Document Number: X27A-G-011-02

Copyright © 2001 Epson Research and Development, Inc. All Rights Reserved.

Information in this document is subject to change without notice. You may download and use this document, but only for your own use in evaluating Seiko Epson/EPSON products. You may not modify the document. Epson Research and Development, Inc. disclaims any representation that the contents of this document are accurate or current. The Programs/Technologies described in this document may contain material protected under U.S. and/or International Patent laws.

EPSON is a registered trademark of Seiko Epson Corporation. All Trademarks are the property of their respective owners.

---

**THIS PAGE LEFT BLANK**

# Table of Contents

<b>1</b>	<b>Introduction</b>	<b>7</b>
<b>2</b>	<b>Interfacing to the MCF5307</b>	<b>8</b>
2.1	The MCF5307 System Bus	8
2.1.1	Overview	8
2.1.2	Normal (Non-Burst) Bus Transactions	8
2.1.3	Burst Cycles	9
2.2	Chip-Select Module	10
<b>3</b>	<b>S1D13705 Bus Interface</b>	<b>11</b>
3.1	Host Bus Pin Connection	11
3.2	Generic #1 Interface Mode	12
<b>4</b>	<b>MCF5307 To S1D13705 Interface</b>	<b>13</b>
4.1	Hardware Description	13
4.2	S1D13705 Hardware Configuration	14
4.3	MCF5307 Chip Select Configuration	15
<b>5</b>	<b>Software</b>	<b>16</b>
<b>6</b>	<b>References</b>	<b>17</b>
6.1	Documents	17
6.2	Document Sources	17
<b>7</b>	<b>Technical Support</b>	<b>18</b>
7.1	EPSON LCD Controllers (S1D13705)	18
7.2	Motorola MCF5307 Processor	18

**THIS PAGE LEFT BLANK**



---

## List of Tables

Table 3-1: Host Bus Interface Pin Mapping . . . . .	11
Table 4-1: Summary of Power-On/Reset Options . . . . .	14
Table 4-2: Host Bus Interface Selection . . . . .	14

## List of Figures

Figure 2-1: MCF5307 Memory Read Cycle . . . . .	9
Figure 2-2: MCF5307 Memory Write Cycle . . . . .	9
Figure 4-1: Typical Implementation of MCF5307 to S1D13705 Interface . . . . .	13

**THIS PAGE LEFT BLANK**

---

# 1 Introduction

This application note describes the hardware required to interface the S1D13705 Embedded Memory LCD Controller and the Motorola MCF5307 Processor. The pairing of these two devices results in an embedded system offering impressive display capability with very low power consumption.

The designs described in this document are presented only as examples of how such interfaces might be implemented. This application note will be updated as appropriate. Please check the Epson Electronics America website at <http://www.eea.epson.com> for the latest revision of this document before beginning any development.

We appreciate your comments on our documentation. Please contact us via email at [techpubs@erd.epson.com](mailto:techpubs@erd.epson.com).

## 2 Interfacing to the MCF5307

### 2.1 The MCF5307 System Bus

The MCF5200/5300 family of processors feature a high-speed synchronous system bus typical of modern microprocessors. This section is an overview of the operation of the CPU bus to establish interface requirements.

#### 2.1.1 Overview

The MCF5307 microprocessor family uses a synchronous address and data bus, very similar in architecture to the MC68040 and MPC8xx. All outputs and inputs are timed with respect to a square-wave reference clock called BCLK0 (Master Clock). This clock runs at a software-selectable divisor rate from the machine cycle speed of the CPU core, typically 20 to 33 MHz. Both the address and the data bus are 32 bits in width. All IO accesses are memory-mapped; there is no separate IO space in the Coldfire architecture.

The bus can support two types of cycles, normal and burst. Burst memory cycles are used to fill on-chip cache memories, and for certain on-chip DMA operations. Normal cycles are used for all other data transfers.

#### 2.1.2 Normal (Non-Burst) Bus Transactions

A data transfer is initiated by the bus master by placing the memory address on address lines A31 through A0 and driving  $\overline{TS}$  (Transfer Start) low for one clock cycle. Several control signals are also provided with the memory address:

- $SIZ[1:0]$  (Transfer Size), which indicate whether the bus cycle is 8, 16, or 32 bits in width.
- $R/\overline{W}$ , which is high for read cycles and low for write cycles.
- A set of transfer type signals ( $TT[1:0]$ ) which provide more detail on the type of transfer being attempted.
- $\overline{TIP}$  (Transfer In Progress), which is asserted whenever a bus cycle is active.

When the peripheral device being accessed has completed the bus transfer, it asserts  $\overline{TA}$  (Transfer Acknowledge) for one clock cycle, completing the bus transaction. Once  $\overline{TA}$  has been asserted, the MCF5307 will not start another bus cycle until  $\overline{TA}$  has been de-asserted. The minimum length of a bus transaction is two bus clocks.

Figure 2-1 illustrates a typical memory read cycle on the MCF5307 system bus, and Figure 2-2 illustrates a memory write cycle.

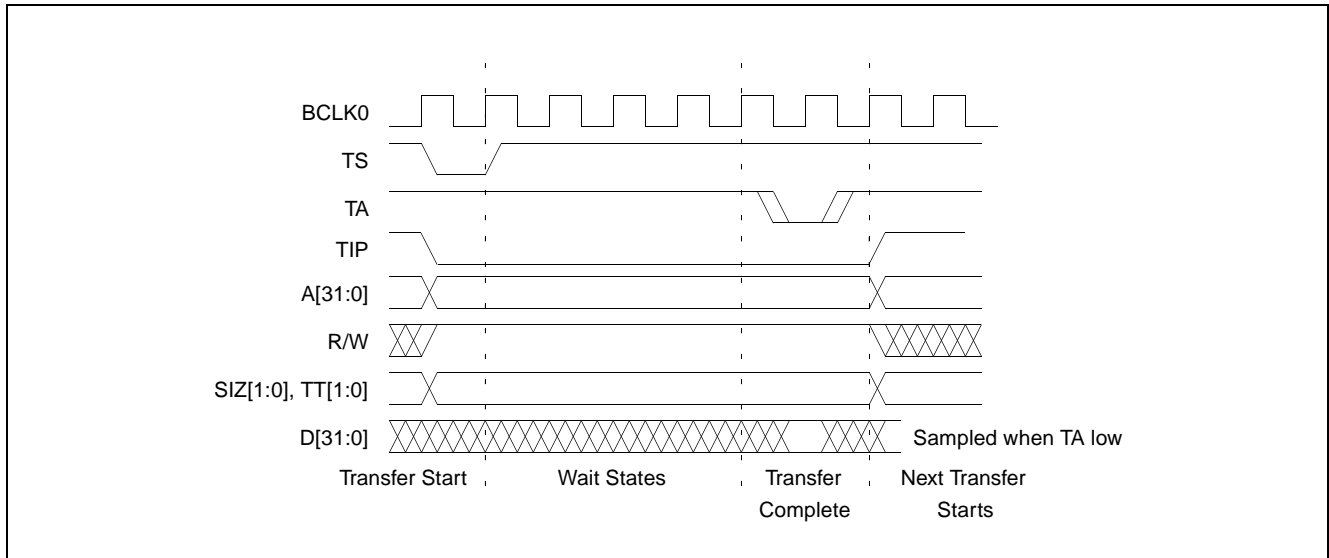

Figure 2-1: MCF5307 Memory Read Cycle

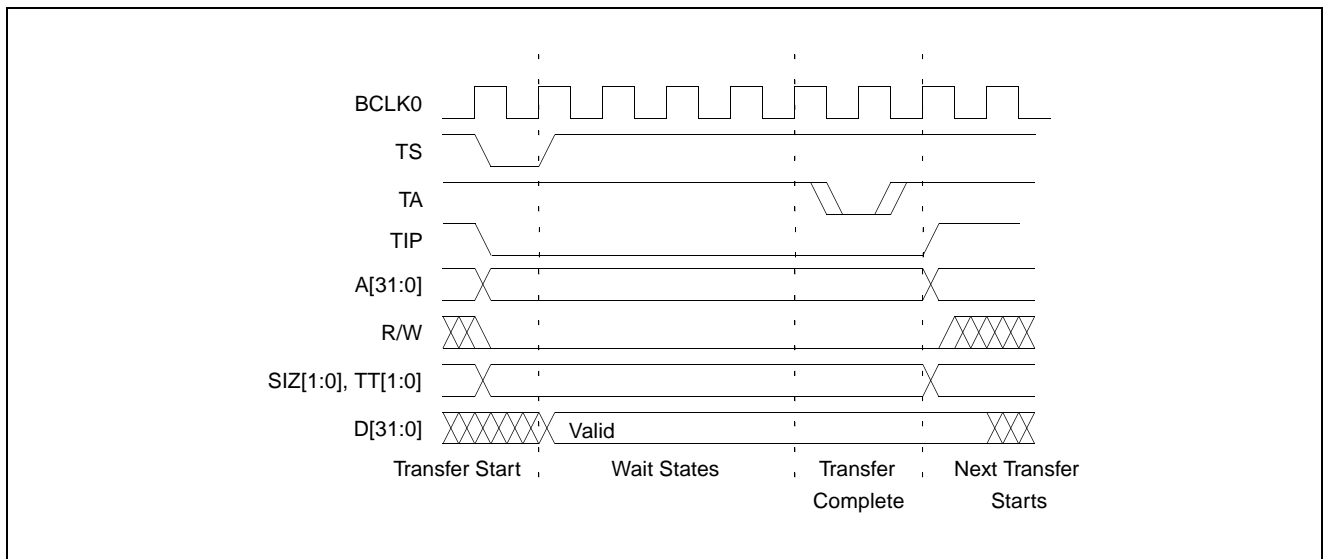

Figure 2-2: MCF5307 Memory Write Cycle

### 2.1.3 Burst Cycles

Burst cycles are very similar to normal cycles, except that they occur as a series of four back-to-back, 32-bit memory reads or writes, with the  $\overline{TIP}$  (Transfer In Progress) output asserted continuously through the burst. Burst memory cycles are mainly intended to facilitate cache line fill from program or data memory; they are typically not used for transfers to or from IO peripheral devices such as the S1D13705. The MCF5307 chip selects provide a mechanism to disable burst accesses for peripheral devices which are not able to support them.

## 2.2 Chip-Select Module

In addition to generating eight independent chip-select outputs, the MCF5307 Chip Select Module can generate active-low Output Enable ( $\overline{OE}$ ) and Write Enable ( $\overline{BWE}$ ) signals compatible with most memory and x86-style peripherals. The MCF5307 bus controller also provides a Read/Write ( $R/\overline{W}$ ) signal which is compatible with most 68K peripherals.

Chip selects 0 and 1 can be programmed independently to respond to any base address and block size. Chip select 0 can be active immediately after reset, and is typically used to control a boot ROM. Chip select 1 is likewise typically used to control a large static or dynamic RAM block.

Chip selects 2 through 7 have fixed block sizes of 2M bytes each. Each has a unique, fixed offset from a common, programmable starting address. These chip selects are well-suited to typical IO addressing requirements.

Each chip select may be individually programmed for port size (8/16/32 bits), 0 to 15 wait states or external acknowledge, address space type, burst or non-burst cycle support, and write protect.

## 3 S1D13705 Bus Interface

This section is a summary of the host bus interface mode used on the S1D13705 to interface to the MCF5307.

The S1D13705 implements a 16-bit interface to the host microprocessor which may operate in one of several modes compatible with most of the popular embedded microprocessor families. The interface mode used for the MCF5307 is:

- Generic #1 (Chip Select, plus individual Read Enable/Write Enable for each byte).

### 3.1 Host Bus Pin Connection

Table 3-1: Host Bus Interface Pin Mapping

S1D13705 Pin Names	Generic #1
AB[15:1]	A[15:1]
AB0	A0
DB[15:0]	D[15:0]
WE1#	WE1#
CS#	External Decode
BCLK	BCLK
BS#	connect to $V_{SS}$
RD/WR#	RD1#
RD#	RD0#
WE0#	WE0#
WAIT#	WAIT#
RESET#	RESET#

For details on configuration, refer to the *S1D13705 Hardware Functional Specification*, document number X27A-A-001-xx.

## 3.2 Generic #1 Interface Mode

Generic #1 interface mode is the most general and least processor-specific interface mode on the S1D13705. The Generic # 1 interface mode was chosen for this interface due to the simplicity of its timing.

The interface requires the following signals:

- BUSCLK is a clock input which is required by the S1D13705 host interface. It is separate from the input clock (CLKI) and is typically driven by the host CPU system clock.
- The address inputs AB0 through AB16, and the data bus DB0 through DB15, connect directly to the CPU address and data bus, respectively. On 32-bit big endian architectures such as the Power PC, the data bus would connect to the high-order data lines; on little endian hosts, or 16-bit big endian hosts, they would connect to the low-order data lines. The hardware engineer must ensure that CNF3 selects the proper endian mode upon reset.
- Chip Select (CS#) is driven by decoding the high-order address lines to select the proper register and memory address space.
- WE0# and WE1# are write enables for the low-order and high-order bytes, respectively, to be driven low when the host CPU is writing data to the S1D13705.
- RD# and RD/WR# are read enables for the low-order and high-order bytes, respectively, to be driven low when the host CPU is reading data from the S1D13705.
- WAIT# is a signal output from the S1D13705 that indicates the host CPU must wait until data is ready (read cycle) or accepted (write cycle) on the host bus. Since host CPU accesses to the S1D13705 may occur asynchronously to the display update, it is possible that contention may occur in accessing the S1D13705 internal registers and/or refresh memory. The WAIT# line resolves these contentions by forcing the host to wait until the resource arbitration is complete. This signal is active low and may need to be inverted if the host CPU wait state signal is active high.
- The Bus Status (BS#) signal is not used in the bus interface for Generic #1 mode. However, BS# is used to configure the S1D13705 for Generic #1 mode and should be tied low (connected to GND).



## 4 MCF5307 To S1D13705 Interface

### 4.1 Hardware Description

The S1D13705 is interfaced to the MCF5307 with a minimal amount of glue logic. One inverter is required to change the polarity of the WAIT# signal, which is an active low signal to insert wait states in the bus cycle, while the MCF5307's Transfer Acknowledge signal ( $\overline{TA}$ ) is an active low signal to end the current bus cycle. The inverter is enabled by CS# so that  $\overline{TA}$  is not driven by the S1D13705 during non-S1D13705 bus cycles. A single resistor is used to speed up the rise time of the WAIT# ( $\overline{TA}$ ) signal when terminating the bus cycle.

The following diagram shows a typical implementation of the MCF5307 to S1D13705 interface.

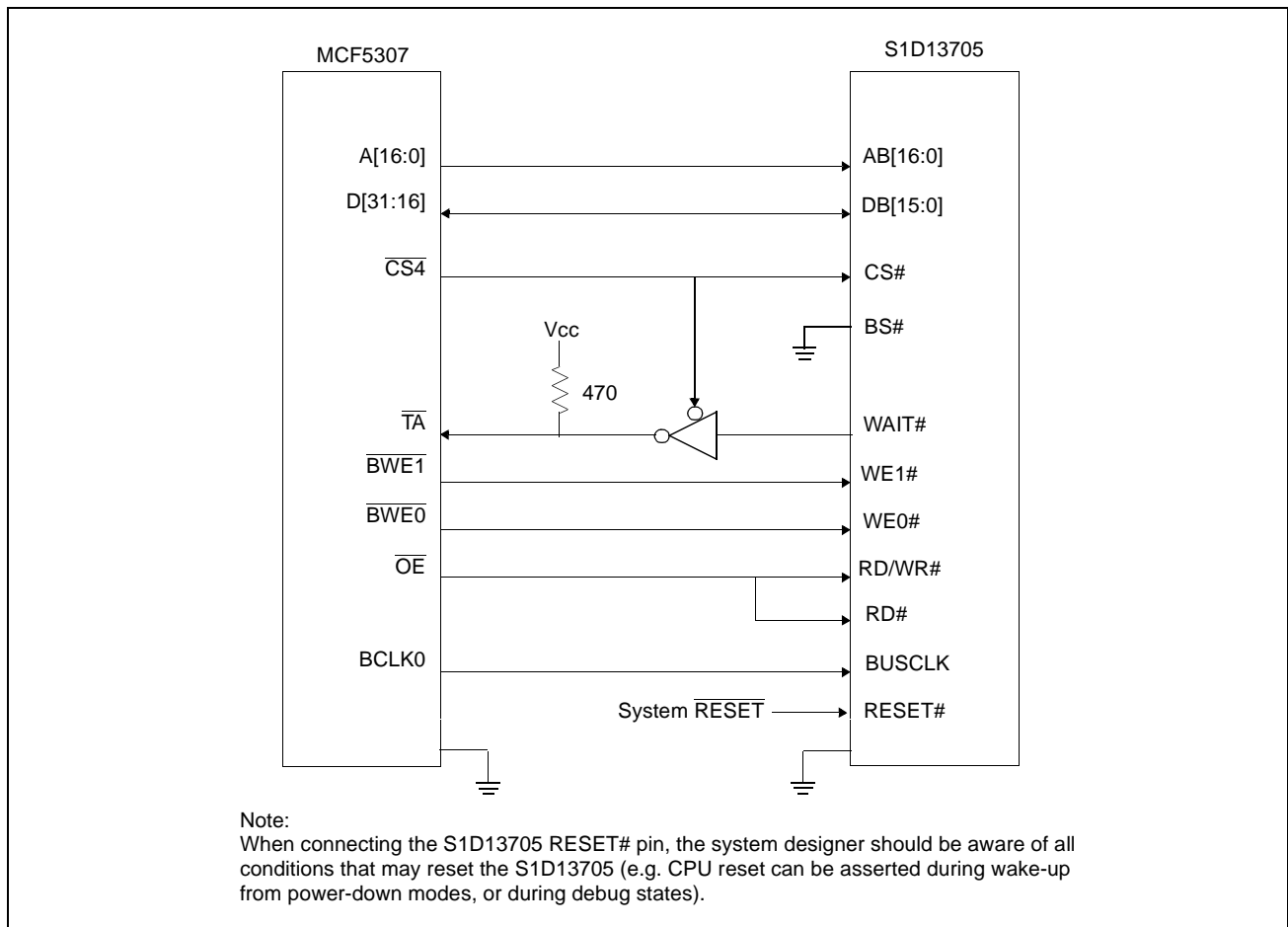

Figure 4-1: Typical Implementation of MCF5307 to S1D13705 Interface

## 4.2 S1D13705 Hardware Configuration

The S1D13705 uses CNF3 through CNF0 and BS# to allow selection of the bus mode and other configuration data on the rising edge of RESET#. Table 4-1: “Summary of Power-On/Reset Options” and Table 4-2: “Host Bus Interface Selection” shows the settings used for the S1D13705 in this interface.

*Table 4-1: Summary of Power-On/Reset Options*

S1D13705 Pin Name	value on this pin at the rising edge of RESET# is used to configure: (0/1)	
	0	1
CNF0		
CNF1	See “Host Bus Selection” table below	See “Host Bus Selection” table below
CNF2		
CNF3	Little Endian	Big Endian

= configuration for MFC5307 support

*Table 4-2: Host Bus Interface Selection*

CNF2	CNF1	CNF0	BS#	Host Bus Interface
1	1	1	0	Generic #1, 16-bit

= configuration for MFC5307 support

## 4.3 MCF5307 Chip Select Configuration

Chip Selects 0 and 1 have programmable block sizes from 64K bytes through 2G bytes. However, these chip selects would normally be needed to control system RAM and ROM. Therefore, one of the IO chip selects CS2 through CS7 is required to address the entire address space of the S1D13705. These IO chip selects have a fixed, 2M byte block size. In the example interface, chip select 4 is used to control the S1D13705. The S1D13705 only uses a 128K byte block with its 80K byte display buffer residing at the start of this 128K byte block and its internal registers occupying the last 32 bytes of this block. This block of memory will be shadowed over the entire 2M byte space. The CSBAR register should be set to the upper 8 bits of the desired base address.

The following options should be selected in the chip select mask registers (CSMR4/5):

- WP = 0 – disable write protect
- AM = 0 - enable alternate bus master access to the S1D13705
- C/I = 1 - disable CPU space access to the S1D13705
- SC = 1 - disable Supervisor Code space access to the S1D13705
- SD = 0 - enable Supervisor Data space access to the S1D13705
- UC = 1 - disable User Code space access to the S1D13705
- UD = 0 - enable User Data space access to the S1D13705
- V = 1 - global enable (“Valid”) for the chip select

The following options should be selected in the chip select control registers (CSCR4/5):

- WS0-3 = 0 - no internal wait state setting
- AA = 0 - no automatic acknowledgment
- PS (1:0) = 1:0 – memory port size is 16 bits
- BEM = 0 – Byte enable/write enable active on writes only
- BSTR = 0 – disable burst reads
- BSTW = 0 – disable burst writes

## 5 Software

Test utilities and Windows® CE v2.0 display drivers are available for the S1D13705. Full source code is available for both the test utilities and the drivers.

The test utilities are configurable for different panel types using a program called 13705CFG, or by directly modifying the source. The Windows CE v2.0 display drivers can be customized by the OEM for different panel types, resolutions and color depths only by modifying the source.

The S1D13705 test utilities and Windows CE v2.0 display drivers are available from your sales support contact or on the internet at <http://www.eea.epson.com>.

---

## 6 References

### 6.1 Documents

- Motorola Inc., *MCF5307 ColdFire® Integrated Microprocessor User's Manual*, Motorola Publication no. MCF5307UM/AD; available on the Internet at <http://www.mot.com/SPS/HPESD/prod/coldfire/5307UM.html>.
- Epson Research and Development, Inc., *S1D13705 Hardware Functional Specification*; Document Number X27A-A-002-xx.
- Epson Research and Development, Inc., *S5U13705B00C Rev. 1.0 ISA Bus Evaluation Board User Manual*; Document Number X27A-G-005-xx.
- Epson Research and Development, Inc., *S1D13705 Programming Notes and Examples*; Document Number X27A-G-002-xx.

### 6.2 Document Sources

- Motorola Inc.: Motorola Literature Distribution Center, (800) 441-2447.
- Motorola website: <http://www.mot.com>.
- Epson Electronics America website: <http://www.eea.epson.com>

## 7 Technical Support

### 7.1 EPSON LCD Controllers (S1D13705)

**Japan**

Seiko Epson Corporation  
Electronic Devices Marketing Division  
421-8, Hino, Hino-shi  
Tokyo 191-8501, Japan  
Tel: 042-587-5812  
Fax: 042-587-5564  
<http://www.epson.co.jp>

**North America**

Epson Electronics America, Inc.  
150 River Oaks Parkway  
San Jose, CA 95134, USA  
Tel: (408) 922-0200  
Fax: (408) 922-0238  
<http://www.eea.epson.com>

**Taiwan, R.O.C.**

Epson Taiwan Technology  
& Trading Ltd.  
10F, No. 287  
Nanking East Road  
Sec. 3, Taipei, Taiwan, R.O.C.  
Tel: 02-2717-7360  
Fax: 02-2712-9164

**Hong Kong**

Epson Hong Kong Ltd.  
20/F., Harbour Centre  
25 Harbour Road  
Wanchai, Hong Kong  
Tel: 2585-4600  
Fax: 2827-4346

**Europe**

Epson Europe Electronics GmbH  
Riesstrasse 15  
80992 Munich, Germany  
Tel: 089-14005-0  
Fax: 089-14005-110

**Singapore**

Epson Singapore Pte., Ltd.  
No. 1  
Temasek Avenue #36-00  
Millenia Tower  
Singapore, 039192  
Tel: 337-7911  
Fax: 334-2716

### 7.2 Motorola MCF5307 Processor

- Motorola Design Line, (800) 521-6274.
- Local Motorola sales office or authorized distributor.

# EPSON®



## S1D13705 Embedded Memory LCD Controller

# Interfacing to the Philips MIPS PR31500/PR31700 Processor

Document Number: X27A-G-012-02

Copyright © 2001 Epson Research and Development, Inc. All Rights Reserved.

Information in this document is subject to change without notice. You may download and use this document, but only for your own use in evaluating Seiko Epson/EPSON products. You may not modify the document. Epson Research and Development, Inc. disclaims any representation that the contents of this document are accurate or current. The Programs/Technologies described in this document may contain material protected under U.S. and/or International Patent laws.

EPSON is a registered trademark of Seiko Epson Corporation. All other trademarks are the property of their respective owners.

---

**THIS PAGE LEFT BLANK**



# Table of Contents

<b>1</b>	<b>Introduction</b>	<b>7</b>
<b>2</b>	<b>Interfacing to the PR31500/PR31700</b>	<b>8</b>
<b>3</b>	<b>S1D13705 Host Bus Interface</b>	<b>9</b>
3.1	Host Bus Pin Connection	9
3.2	Generic #1 Interface Mode	10
3.3	Generic #2 Interface Mode	11
<b>4</b>	<b>Direct Connection to the Philips PR31500/PR31700</b>	<b>12</b>
4.1	General Description	12
4.2	Memory Mapping and Aliasing	13
4.3	S1D13705 Configuration and Pin Mapping	14
<b>5</b>	<b>Using the ITE IT8368E PC Card Buffer</b>	<b>15</b>
5.1	Hardware Description	15
5.2	IT8368E Configuration	17
5.3	Memory Mapping and Aliasing	17
5.4	S1D13705 Configuration	18
<b>6</b>	<b>Software</b>	<b>19</b>
<b>7</b>	<b>Technical Support</b>	<b>20</b>
7.1	EPSON LCD Controllers (S1D13705)	20
7.2	Philips MIPS PR31500/PR31700 Processor	20
7.3	ITE IT8368E	20

**THIS PAGE LEFT BLANK**

---

## List of Tables

Table 3-1: Host Bus Interface Pin Mapping . . . . .	9
Table 4-1: S1D13705 Configuration for Direct Connection. . . . .	14
Table 5-1: PR31500/PR31700 to PC Card Slots Address Mapping With and Without the IT8368E. . . . .	17
Table 5-2: S1D13705 Configuration Using the IT8368E . . . . .	18

## List of Figures

Figure 4-1: S1D13705 to PR31500/PR31700 Direct Connection . . . . .	12
Figure 5-1: S1D13705 to PR31500/PR31700 Connection Using an IT8368E . . . . .	16

**THIS PAGE LEFT BLANK**

# 1 Introduction

This application note describes the hardware required to interface the S1D13705 Embedded Memory LCD Controller and the Philips MIPS PR31500/PR31700 Processor. The pairing of these two devices results in an embedded system offering impressive display capability with very low power consumption.

The designs described in this document are presented only as examples of how such interfaces might be implemented. This application note will be updated as appropriate. Please check the Epson Electronics America website at <http://www.eea.epson.com> for the latest revision of this document before beginning any development.

We appreciate your comments on our documentation. Please contact us via email at [techpubs@erd.epson.com](mailto:techpubs@erd.epson.com).

## 2 Interfacing to the PR31500/PR31700

The Philips MIPS PR31500/PR31700 processor supports up to two PC Card (PCMCIA) slots. It is through this host bus interface that the S1D13705 connects to the PR31500/PR31700 processor.

The S1D13705 can be successfully interfaced using one of two configurations:

- Direct connection to PR31500/PR31700 (see Section 4, *Direct Connection to the Philips PR31500/PR31700* on page 12).
- System design using one ITE IT8368E PC Card/GPIO buffer chip (see Section 5, *Using the ITE IT8368E PC Card Buffer* on page 15).

## 3 S1D13705 Host Bus Interface

This section is a summary of the host bus interface modes available on the S1D13705 that would be used to interface to the PR31500/PR31700.

The S1D13705 implements a 16-bit interface to the host microprocessor which may operate in one of several modes compatible with most of the popular embedded microprocessor families. The interface modes used for the PR31500/PR31700 are:

- Generic #1 (Chip Select, plus individual Read Enable/Write Enable for each byte).
- Generic #2 (External Chip Select, shared Read/Write Enable for high byte, individual Read/Write Enable for low byte).

### 3.1 Host Bus Pin Connection

The following table shows the functions of each host bus interface signal.

*Table 3-1: Host Bus Interface Pin Mapping*

S1D13705 Pin Names	Generic #1	Generic #2
AB[15:1]	A[15:1]	A[15:1]
AB0	A0	A0
DB[15:0]	D[15:0]	D[15:0]
WE1#	WE1#	BHE#
CS#	External Decode	External Decode
BCLK	BCLK	BCLK
BS#	connect to $V_{SS}$	connect to IO $V_{DD}$
RD/WR#	RD1#	connect to IO $V_{DD}$
RD#	RD0#	RD#
WE0#	WE0#	WE#
WAIT#	WAIT#	WAIT#
RESET#	RESET#	RESET#

For details on configuration, refer to the *S1D13705 Hardware Functional Specification*, document number X27A-A-001-xx.

## 3.2 Generic #1 Interface Mode

Generic #1 interface mode is the most general and least processor-specific interface mode on the S1D13705. The Generic # 1 interface mode was chosen for this interface due to the simplicity of its timing.

The interface requires the following signals:

- BUSCLK is a clock input which is required by the S1D13705 host interface. It is separate from the input clock (CLKI) and is typically driven by the host CPU system clock.
- The address inputs AB0 through AB16, and the data bus DB0 through DB15, connect directly to the CPU address and data bus, respectively. On 32-bit big endian architectures such as the Power PC, the data bus would connect to the high-order data lines; on little endian hosts, or 16-bit big endian hosts, they would connect to the low-order data lines. The hardware engineer must ensure that CNF3 selects the proper endian mode upon reset.
- Chip Select (CS#) is driven by decoding the high-order address lines to select the proper register and memory address space.
- WE0# and WE1# are write enables for the low-order and high-order bytes, respectively, to be driven low when the host CPU is writing data to the S1D13705. These signals must be generated by external hardware based on the control outputs from the host CPU.
- RD# and RD/WR# are read enables for the low-order and high-order bytes, respectively, to be driven low when the host CPU is reading data from the S1D13705. These signals must be generated by external hardware based on the control outputs from the host CPU.
- WAIT# is a signal output from the S1D13705 that indicates the host CPU must wait until data is ready (read cycle) or accepted (write cycle) on the host bus. Since host CPU accesses to the S1D13705 may occur asynchronously to the display update, it is possible that contention may occur in accessing the S1D13705 internal registers and/or refresh memory. The WAIT# line resolves these contentions by forcing the host to wait until the resource arbitration is complete. This signal is active low and may need to be inverted if the host CPU wait state signal is active high.
- The Bus Status (BS#) signal is not used in the bus interface for Generic #1 mode. However, BS# is used to configure the S1D13705 for Generic #1 mode and should be tied low (connected to GND).



### 3.3 Generic #2 Interface Mode

Generic #2 interface mode is a general and non-processor-specific interface mode on the S1D13705. The Generic # 2 interface mode was chosen for this interface due to the simplicity of its timing and compatibility with the PR31500/PR31700 control signals.

The interface requires the following signals:

- BUSCLK is a clock input which synchronizes transfers between the host CPU and the S1D13705. It is separate from the input clock (CLKI) and is typically driven by the host CPU system clock.
- The address inputs AB0 through AB16, and the data bus DB0 through DB15, connect directly to the CPU address and data bus, respectively. On 32-bit big endian architectures such as the Power PC, the data bus would connect to the high-order data lines; on little endian hosts, or 16-bit big endian hosts, they would connect to the low-order data lines. The hardware engineer must ensure that CNF3 selects the proper endian mode upon reset.
- Chip Select (CS#) is driven by decoding the high-order address lines to select the proper register and memory address space.
- WE1# is the high byte enable for both read and write cycles.
- WE0# is the write enable signal for the S1D13705, to be driven low when the host CPU is writing data from the S1D13705.
- RD# is the read enable for the S1D13705, to be driven low when the host CPU is reading data from the S1D13705.
- WAIT# is a signal which is output from the S1D13705 to the host CPU that indicates when data is ready (read cycle) or accepted (write cycle) on the host bus. Since host CPU accesses to the S1D13705 may occur asynchronously to the display update, it is possible that contention may occur in accessing the 13705 internal registers and/or refresh memory. The WAIT# line resolves these contentions by forcing the host to wait until the resource arbitration is complete. This signal is active low and may need to be inverted if the host CPU wait state signal is active high.
- The Bus Status (BS#) and Read/Write (RD/WR#) signals are not used in the bus interface for Generic #2 mode. However, BS# is used to configure the S1D13705 for Generic #2 mode and should be tied high (connected to IO V<sub>DD</sub>). RD/WR# should also be tied high.

## 4 Direct Connection to the Philips PR31500/PR31700

### 4.1 General Description

In this example implementation the S1D13705 occupies the PR31500/PR31700 PC Card slot #1.

The S1D13705 is easily interfaced to the PR31500/PR31700 with minimal additional logic. The address bus of the PR31500/PR31700 PC Card interface is multiplexed and must be demultiplexed using an advanced CMOS latch (e.g., 74AHC373). The direct connection approach makes use of the S1D13705 in its "Generic #2" interface configuration.

The following diagram demonstrates a typical implementation of the interface.

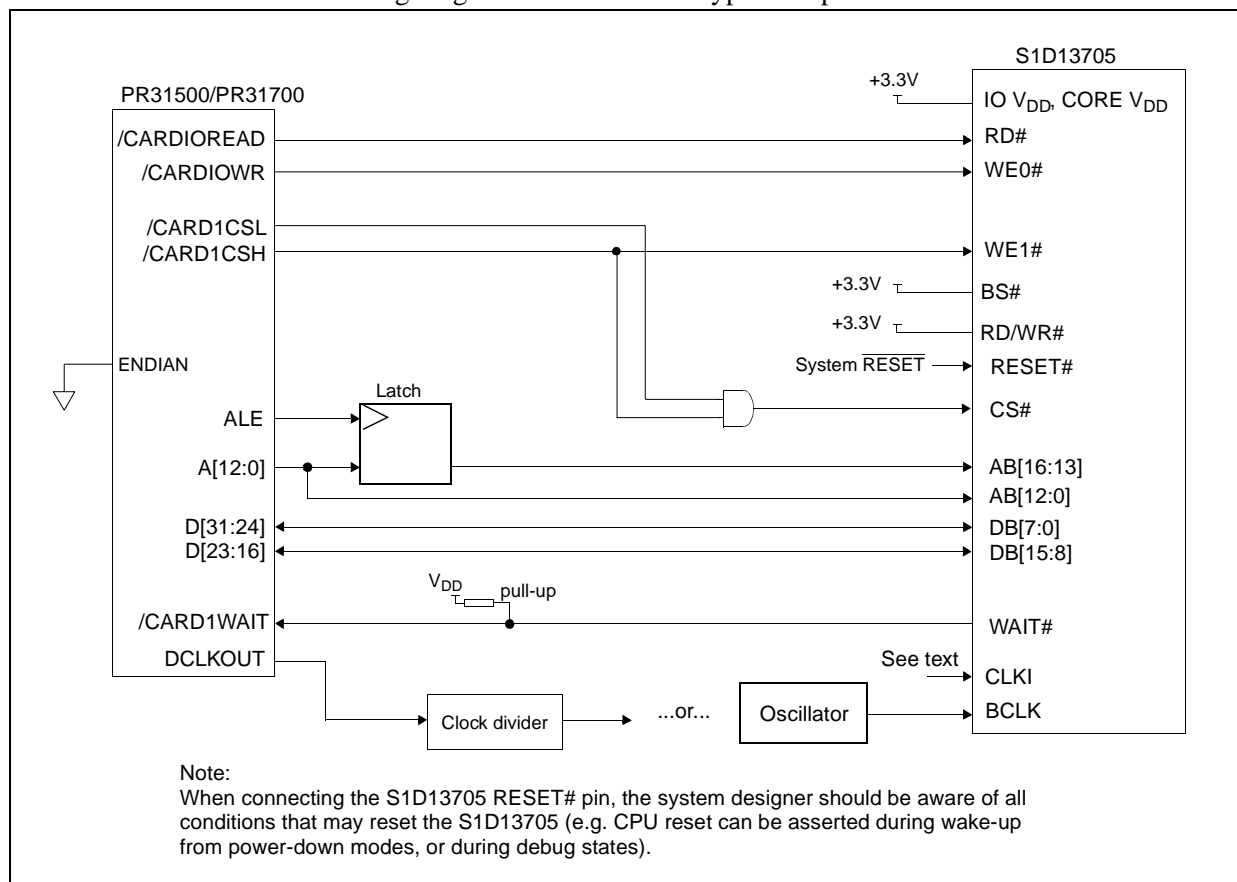

Figure 4-1: S1D13705 to PR31500/PR31700 Direct Connection

#### Note

See Section 3.1 on page 9 and Section 3.3 on page 11 for Generic #2 pin descriptions.

The “Generic #2” host interface control signals of the S1D13705 are asynchronous with respect to the S1D13705 bus clock. This gives the system designer full flexibility to choose the appropriate source (or sources) for CLKI and BCLK. The choice of whether both clocks should be the same, and whether to use DCLKOUT (divided) as clock source, should be based on the desired:

- pixel and frame rates.
- power budget.
- part count.
- maximum S1D13705 clock frequencies.

The S1D13705 also has internal clock dividers providing additional flexibility.

## 4.2 Memory Mapping and Aliasing

The S1D13705 requires an addressing space of 128K bytes. The on-chip display memory occupies the range 0 through 13FFFh. The registers occupy the range 1FFE0h through 1FFFFh. The PR31500/PR31700 demultiplexed address lines A17 and above are ignored, thus the S1D13705 is aliased 512 times at 128K byte intervals over the 64M byte PC Card slot #1 memory space. In this example implementation, the PR31500/PR31700 control signal /CARDREG is ignored; therefore the S1D13705 also takes up the entire PC Card slot 1 configuration space.

### Note

If aliasing is undesirable, additional decoding circuitry must be added.

## 4.3 S1D13705 Configuration and Pin Mapping

The S1D13705 is configured at power up by latching the state of the CNF[3:0] pins. Pin BS# also plays a role in host bus interface configuration. For details on configuration, refer to the *S1D13705 Hardware Functional Specification*, document number X27A-A-001-xx.

The table below shows those configuration settings relevant to the direct connection approach.

*Table 4-1: S1D13705 Configuration for Direct Connection*

S1D13705 Configuration Pin	Value hard wired on this pin is used to configure:	
	1 (IO V <sub>DD</sub> )	0 (V <sub>SS</sub> )
BS#	Generic #2	Generic #1
CNF3	Big Endian	Little Endian
CNF[2:0]	111: Generic #1 or #2	

= configuration for Philips PR31500/PR31700 host bus interface

## 5 Using the ITE IT8368E PC Card Buffer

If the system designer uses the ITE IT8368E PC Card and multiple-function I/O buffer, the S1D13705 can be interfaced so that it “shares” a PC Card slot. The S1D13705 is mapped to a rarely-used 16M byte portion of the PC Card slot buffered by the IT8368E. This makes the S1D13705 virtually transparent to PC Card devices that use the same slot.

### 5.1 Hardware Description

The ITE8368E has been specially designed to support EPSON LCD controllers. The ITE IT8368E provides eleven Multi-Function IO pins (MFIO). Configuration registers may be used to allow these MFIO pins to provide the control signals required to implement the S1D13705 CPU interface.

The PR31500/PR31700 processor only provides addresses A[12:0]; therefore devices requiring more address space must use an external device to latch A[25:13]. The IT8368E’s MFIO pins can be configured to provide this latched address.

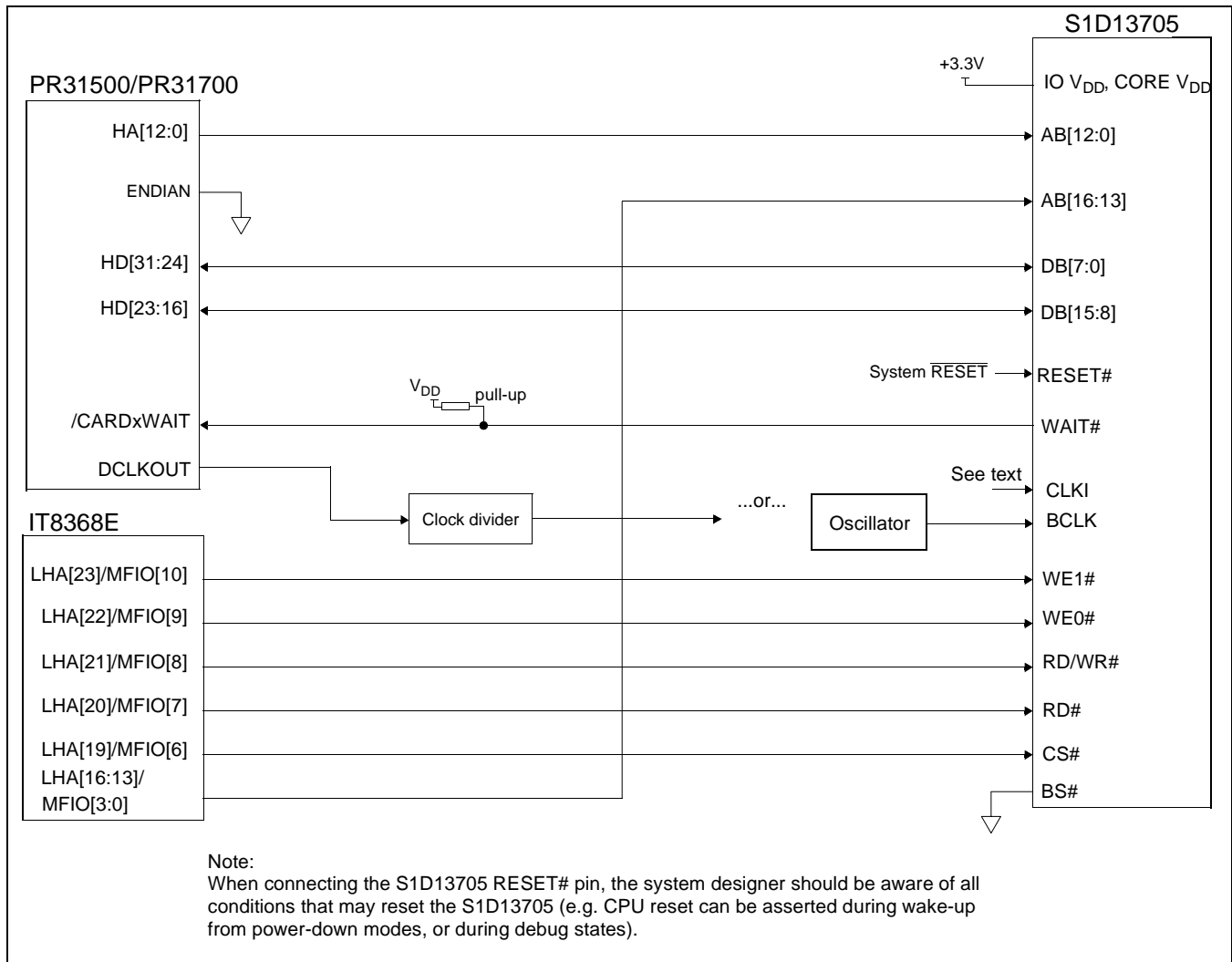

Figure 5-1: S1D13705 to PR31500/PR31700 Connection Using an IT8368E

#### Note

See Section 3.1 on page 9 and Section 3.2 on page 10 for Generic #1 pin descriptions.

The “Generic #1” host interface control signals of the S1D13705 are asynchronous with respect to the S1D13705 bus clock. This gives the system designer full flexibility to choose the appropriate source (or sources) for CLKI and BCLK. The choice of whether both clocks should be the same, and whether to use DCLKOUT (divided) as clock source, should be based on the desired:

- pixel and frame rates.
- power budget.
- part count.
- maximum S1D13705 clock frequencies.

The S1D13705 also has internal clock dividers providing additional flexibility.

## 5.2 IT8368E Configuration

The IT8368E provides eleven multi-function IO pins (MFIO). The IT8368E must have both “Fix Attribute/IO” and “VGA” modes on. When both these modes are enabled, the MFIO pins provide control signals needed by the S1D13705 host bus interface, and a 16M byte portion of the system PC Card attribute and IO space is allocated to address the S1D13705. When accessing the S1D13705 the associated card-side signals are disabled in order to avoid any conflicts.

For mapping details, refer to section 3.3: “Memory Mapping and Aliasing.” For connection details see Figure 5-1: “S1D13705 to PR31500/PR31700 Connection Using an IT8368E,” on page 16. For further information on the IT8368E, refer to the *IT8368E PC Card/GPIO Buffer Chip Specification*.

### Note

When a second IT8368E is used, that circuit should not be set in VGA mode.

## 5.3 Memory Mapping and Aliasing

When the PR31500/PR31700 accesses the PC Card slots *without* the ITE IT8368E, its system memory is mapped as in Table 5-1: *PR31500/PR31700 to PC Card Slots Address Mapping With and Without the IT8368E*.

### Note

Bit CARD1IOEN or CARD2IOEN, depending on which card slot is used, must to be set to 0 in the PR31500/PR31700 Memory Configuration Register 3.

When the PR31500/PR31700 accesses the PC Card slots buffered through the ITE IT8368E, bits CARD1IOEN and CARD2IOEN are ignored and the attribute/IO space of the PR31500/PR31700 is divided into Attribute, I/O and S1D13705 access. Table 5-1: *PR31500/PR31700 to PC Card Slots Address Mapping With and Without the IT8368E* provides all details of the Attribute/IO address reallocation by the IT8368E.

Table 5-1: PR31500/PR31700 to PC Card Slots Address Mapping With and Without the IT8368E

PC Card Slot #	TX3912 Address	Size	Using the ITE IT8368E	Direct Connection, CARDnIOEN=0	Direct Connection, CARDnIOEN=1
1	0800 0000h	16M byte	Card 1 IO	S1D13705 (aliased 512 times at 128K byte intervals)	Card 1 IO
	0900 0000h	16M byte	S1D13705 (aliased 128 times at 128K byte intervals)		
	0A00 0000h	32M byte	Card 1 Attribute		
	6400 0000h	64M byte	Card 1 Memory	S1D13705 (aliased 512 times at 128K byte intervals)	
2	0C00 0000h	16M byte	Card 2 IO	S1D13705 (aliased 512 times at 128K byte intervals)	Card 2 IO
	0D00 0000h	16M byte	S1D13705 (aliased 128 times at 128K byte intervals)		
	0E00 0000h	32M byte	Card 2 Attribute		
	6800 0000h	64M byte	Card 2 Memory	S1D13705 (aliased 512 times at 128K byte intervals)	

## 5.4 S1D13705 Configuration

The S1D13705 is configured at power up by latching the state of the CNF[3:0] pins. Pin BS# also plays a role in host bus interface configuration. For details on configuration, refer to the *S1D13705 Hardware Functional Specification*, document number X27A-A-001-xx.

The table below shows those configuration settings relevant to this specific interface.

*Table 5-2: S1D13705 Configuration Using the IT8368E*

S1D13705 Configuration Pin	Value hard wired on this pin is used to configure:	
	1 (IO V <sub>DD</sub> )	0 (V <sub>SS</sub> )
BS#	Generic #2	Generic #1
CNF3	Big Endian	Little Endian
CNF[2:0]	111: Generic #1 or #2	

= configuration for connection using ITE IT8368E



## 6 Software

Test utilities and Windows® CE v2.0 display drivers are available for the S1D13705. Full source code is available for both the test utilities and the drivers.

The test utilities are configurable for different panel types using a program called 1357CFG, or by directly modifying the source. The Windows CE v2.0 display drivers can be customized by the OEM for different panel types, resolutions and color depths only by modifying the source.

The S1D13705 test utilities and Windows CE v2.0 display drivers are available from your sales support contact or [www.eea.epson.com](http://www.eea.epson.com).

## 7 Technical Support

### 7.1 EPSON LCD Controllers (S1D13705)

**Japan**

Seiko Epson Corporation  
Electronic Devices Marketing Division  
421-8, Hino, Hino-shi  
Tokyo 191-8501, Japan  
Tel: 042-587-5812  
Fax: 042-587-5564

**North America**

Epson Electronics America, Inc.  
150 River Oaks Parkway  
San Jose, CA 95134, USA  
Tel: (408) 922-0200  
Fax: (408) 922-0238  
<http://www.eea.epson.com>

**Taiwan, R.O.C.**

Epson Taiwan Technology  
& Trading Ltd.  
10F, No. 287  
Nanking East Road  
Sec. 3, Taipei, Taiwan, R.O.C.  
Tel: 02-2717-7360  
Fax: 02-2712-9164

**Europe**

Epson Europe Electronics GmbH  
Riesstrasse 15  
80992 Munich, Germany  
Tel: 089-14005-0  
Fax: 089-14005-110

**Hong Kong**

Epson Hong Kong Ltd.  
20/F., Harbour Centre  
25 Harbour Road  
Wanchai, Hong Kong  
Tel: 2585-4600  
Fax: 2827-4346

**Singapore**

Epson Singapore Pte., Ltd.  
No. 1  
Temasek Avenue #36-00  
Millenia Tower  
Singapore, 039192  
Tel: 337-7911  
Fax: 334-2716

### 7.2 Philips MIPS PR31500/PR31700 Processor

**Philips Semiconductors**

Handheld Computing Group  
4811 E. Arques Avenue  
M/S 42, P.O. Box 3409  
Sunnyvale, CA 94088-3409  
Tel: (408) 991-2313  
<http://www.philips.com>

### 7.3 ITE IT8368E

**Integrated Technology Express, Inc.**

Sales & Marketing Division  
2710 Walsh Avenue  
Santa Clara, CA 95051, USA  
Tel: (408) 980-8168  
Fax: (408) 980-9232  
<http://www.iteusa.com>



## **S1D13704/5 Embedded Memory Color LCD Controller**

# **S5U13704/5 - TMPR3912/22U CPU Module**

**Document Number: X00A-G-004-02**

Copyright © 1998, 2001 Epson Research and Development, Inc. All Rights Reserved.

Information in this document is subject to change without notice. You may download and use this document, but only for your own use in evaluating Seiko Epson/EPSON products. You may not modify the document. Epson Research and Development, Inc. disclaims any representation that the contents of this document are accurate or current. The Programs/Technologies described in this document may contain material protected under U.S. and/or International Patent laws.

EPSON is a registered trademark of Seiko Epson Corporation. All other trademarks are the property of their respective owners.

---

**THIS PAGE LEFT BLANK**

## Table of Contents

<b>1</b>	<b>Introduction</b>	<b>7</b>
1.1	General Description	7
<b>2</b>	<b>S1D13704/5 Bus Interface</b>	<b>8</b>
2.1	Bus Interface Modes	8
2.2	Generic #2 Interface Mode	9
<b>3</b>	<b>TMPR3912/22U and S1D13704/5 Interface</b>	<b>10</b>
3.1	Hardware Connections	10
3.2	Memory Mapping and Aliasing	11
3.3	S1D13704/5 Configuration and Pin Mapping	11
<b>4</b>	<b>CPU Module Description</b>	<b>12</b>
4.1	Clock Signals	12
4.1.1	BUSCLK	12
4.1.2	CLKI	12
4.2	LCD Connectors	12
4.2.1	50-pin LCD Module Connector, J3	12
4.2.2	Standard Epson LCD Connector, J4	13
4.3	LCD Controller	13
4.3.1	S1D13704 vs. S1D13705	13
4.3.2	LCDPWR Polarity	13
4.3.3	S1D13704/75 Chip Select	13

**THIS PAGE LEFT BLANK**

---

## List of Tables

Table 3-1:	S1D13704/5 Configuration for Generic #2 Bus Interface . . . . .	11
Table 3-2:	S1D13704/5 Generic #2 Interface Pin Mapping . . . . .	11

## List of Figures

Figure 3-1:	S1D13704 to TMPR3912/22U Interface . . . . .	10
-------------	--	----

**THIS PAGE LEFT BLANK**



# 1 Introduction

This manual describes the interface between the S1D13704/5 LCD Controller (LCDC) and the TMPR3912/22U microprocessor as implemented on the Toshiba 3912/22 and S1D13704/5 CPU Module. This module is used in conjunction with the Toshiba TX RISC Reference Platform.

For more information regarding the S1D13704 or S1D13705 refer to their respective Hardware Functional Specification, document number X26A-A-001-xx and X27A-A-001-xx respectively.

For more information regarding the TMPR3912/22U, refer to the TMPR3912/22U 32-Bit MIPS RISC Processor User's Manual. See the Toshiba website under semiconductors at <http://toshiba.com/taec/nonflash/indexproducts.html>.

## 1.1 General Description

The Toshiba TX RISC Reference Kit consists of 6 boards which include: a main board, a CPU board, a EPROM board, a FMEM board, a debug board, and an analog board. The main board acts as the motherboard for all the other add-on boards. In addition to these boards, there is an LCD module that connects to the CPU board. In order to support the add-on LCD panel that connects to the LCD module, the CPU board microprocessor must have an internal LCD controller or the CPU board must have an LCD controller on it that interfaces to the microprocessor.

For the TMPR3912/22U microprocessor, the S1D13704 or S1D13705 LCDC is used to provide support for LCD panels. The LCDC is socketed so that it can be interchanged between the S1D13704 and the S1D13705. These controllers are very similar, with the main differences being the amount of embedded display memory and the lookup-table architecture (LUT). The S1D13704 has 40K bytes of display memory and the S1D13705 has 80K bytes.

The Toshiba TMPR3912/22U processor supports two PC Card (PCMCIA) slots on the TX RISC Reference Platform. The S1D13704 or S1D13705 LCD controller uses the PC Card slot 1 to interface to the TMPR3912/22U, therefore, this slot is unavailable for use on the TX RISC Reference Platform.

## 2 S1D13704/5 Bus Interface

This section is summary of the bus interface modes available on the S1D13704 and S1D13705 LCDCs, and offers some detail on the Generic #2 bus mode used to implement the interface to the TMPR3912/22U.

### 2.1 Bus Interface Modes

The S1D13704/5 implements a general-purpose 16-bit interface to the host microprocessor, which may operate in one of several modes compatible with most of the popular embedded microprocessor families.

Bus interface mode selections are made during reset by sampling the state of the configuration pins CNF[2:0] and the BS# line. Table 5-1 in the S1D13704 or S1D13705 Hardware Functional Specification details the values needed for the configuration pins and BS# to select the desired mode.

## 2.2 Generic #2 Interface Mode

Generic #2 interface mode is a general and non-processor-specific interface mode on the S1D13704/5. The Generic # 2 interface mode was chosen for this interface due to its compatibility with the PC Card interface.

The interface requires the following signals:

- BUSCLK is a clock input which synchronizes transfers between the host CPU and the S1D13704/5. BUSCLK is separate from the input clock (CLKI) and is typically driven by the host CPU system clock.
- The address inputs AB0 through AB15, and the data bus DB0 through DB15, connect directly to the CPU address and data bus, respectively. On 32-bit big endian architectures such as the Power PC, the data bus would connect to the high-order data lines; on little endian hosts, or 16-bit big endian hosts, they would connect to the low-order data lines. The hardware engineer must ensure that CNF3 selects the proper endian mode upon reset.
- Chip Select (CS#) is driven by decoding the high-order address lines to select the proper memory address space.
- WE1# is the high byte enable for both read and write cycles and WE0# is the enable signal for a write access. These must be generated by external decode hardware based upon the control outputs from the host CPU.
- RD# is the read enable for the S1D13704/5, to be driven low when the host CPU is reading data from the S1D13704/5. RD# must be generated by external decode hardware based upon the control outputs from the host CPU.
- WAIT# is a signal which is output from the S1D13704/5 to the host CPU that indicates when data is ready (read cycle) or accepted (write cycle) on the host bus. Since host CPU accesses to the S1D13704/5 may occur asynchronously to the display update, it is possible that contention may occur in accessing the 13704/5 internal registers and/or refresh memory. The WAIT# line resolves these contentions by forcing the host to wait until the resource arbitration is complete. This signal is active low and may need to be inverted if the host CPU wait state signal is active high.
- The Bus Status (BS#) and Read/Write (RD/WR#) signals are not used in the bus interface for Generic #2 mode. However, BS# is used to configure the S1D13704/5 for Generic #2 mode and must be tied high (connected to IOVDD = 3.3V). RD/WR# must also be tied high.

### 3 TMPR3912/22U and S1D13704/5 Interface

#### 3.1 Hardware Connections

The S1D13704/5 occupies the TMPR3912/22U's PC Card slot #1. Therefore, this slot cannot be used for other devices on the main board. The Generic # 2 bus mode of the S1D13704/5 is used to interface to this PC Card slot #1.

The S1D13704/5 is interfaced to the TMPR3912/22U with minimal glue logic. Since the address bus of the TMPR3912/22U is multiplexed, it is demultiplexed using an advanced CMOS latch (74ACT373) to obtain the higher address bits needed for the S1D13704/5.

The following diagram demonstrates the implementation of the interface.

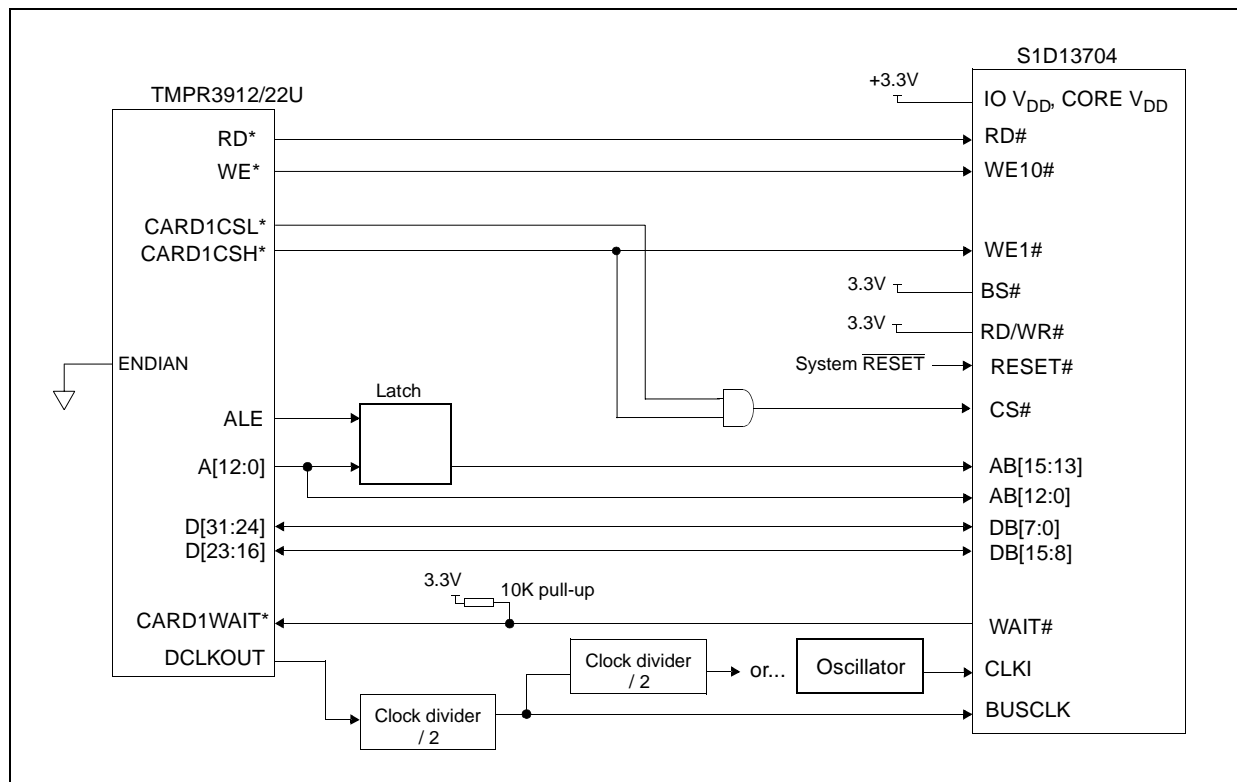

Figure 3-1: S1D13704 to TMPR3912/22U Interface

### 3.2 Memory Mapping and Aliasing

The S1D13704 requires an addressing space of 64K bytes while the S1D13705 requires 128K. The on-chip display memory occupies the range 0 through 9FFFh. The registers occupy the range FFE0h through FFFFh. The TMPR3912/22U demultiplexed address lines A16 and above are ignored if the S1D13704 is used, thus it is aliased 1024 times at 64K byte intervals over the 64M byte PC Card slot #1 memory space. If the S1D13705 is used, address lines A17 and above are ignored; therefore the S1D13705 is aliased 512 times at 128K byte intervals. The TMPR3912/22U control signal CARDREG# is ignored; therefore the S1D13704 also takes up the entire PC Card slot #1 configuration space.

**Note**

If aliasing is undesirable, additional decoding circuitry must be added.

### 3.3 S1D13704/5 Configuration and Pin Mapping

The S1D13704/5 host bus interface is configured at power up by latching the state of the CNF[3:0] pins. Pin BS# also plays a role in host bus interface configuration. One additional configuration pin for the S1D13704, CNF4, is also used to set the polarity of the LCDPWR signal.

The table below shows the configuration pin connections to configure the S1D13704/5 for use with the TMPR3912/22U microprocessor.

*Table 3-1: S1D13704/5 Configuration for Generic #2 Bus Interface*

S1D13704 Configuration Pin	Value hard wired on this pin is used to configure:	
	1 (IO V <sub>DD</sub> )	0 (V <sub>SS</sub> )
BS#	Generic #2	Generic #1
CNF3	Big Endian	Little Endian
CNF[2:0]	111: Generic #1 or #2	

= configuration for Toshiba TMPR3912/22U host bus interface

When the S1D13704/5 is configured for Generic #2 bus interface mode, the host interface pins are mapped as in the table below.

*Table 3-2: S1D13704/5 Generic #2 Interface Pin Mapping*

Pin Name	Pin Function
WE1#	BHE#
BS#	Connect to IO V <sub>DD</sub>
RD/WR#	Connect to IO V <sub>DD</sub>
RD#	RD#
WE0#	WE#

## 4 CPU Module Description

This section will describe the various parts of the CPU module that pertain to the S1D13704/5 LCD Controller.

### 4.1 Clock Signals

#### 4.1.1 BUSCLK

Because the bus clock for the S1D13704/5 does not need to be synchronous with the bus interface control signals, a lot of flexibility is available in the choice for BUSCLK. In this CPU module, BUSCLK is a divided by two version of the SDRAM clock signal, DCLKOUT. Since DCLKOUT equals 73.728MHz, BUSCLK = 36.864MHz.

#### 4.1.2 CLKI

The pixel clock for the S1D13704/5, CLKI, is also asynchronous with respect to the interface control signals. This clock is selected based upon panel frame rates, power vs performance budget, and maximum input frequencies. The maximum CLKI input is 25MHz if the internal CLKI/2 isn't used, and if it is used the maximum input is 50MHz.

On the CPU module, CLKI's default input is a divided by four version of DCLKOUT, which gives a CLKI = 18.432MHz. This frequency gives good performance for 320x240 resolution panels for both portrait and landscape modes. If power saving is desired, the CLKI can be reduced by using the internal CLKI/2 and the various PCLK and MCLK dividers for portrait mode.

A socket for an external oscillator is also provided if a different frequency is required. This option is selected by positioning jumper JP8 in the 2 3 position and adding a standard 14-DIP type oscillator in the socket U10.

### 4.2 LCD Connectors

#### 4.2.1 50-pin LCD Module Connector, J3

The standard connector used on Toshiba's CPU Modules to connect to the LCD module is included in this CPU module. All twelve LCD data lines, FPDAT[11:0], from the S1D13704/5, as well as the five video control signals, FPFRAME, FPSHIFT, FPLINE, DRDY, LCDPWR, are passed through this connector. Through this connector, the S1D13704/5 supports monochrome and color STN panels up to a resolution of 640x480 as well as color TFT/D-TFT up to a resolution of 640x480. All touch panel signals from the main board have also been routed through this connector.

## 4.2.2 Standard Epson LCD Connector, J4

A shrouded 40-pin header, J4, is also added to the CPU module to connect to LCD panels. This header is the standard LCD connector used on Epson Research and Development evaluation boards and can be used to directly connect LCD panels to the S1D13704/5 controller. All LCD signals are buffered to allow 3.3V or 5.0V logic LCD panels to be connected. Jumper, JP9, selects between these two types of panels.

A positive power supply for panels requiring a positive bias voltage is supplied to header J4, by the LCD module through the 50-pin LCD module connector, J3. No negative power supply is available on the LCD module, therefore only panels which have their own bias voltage supply, or those that use a positive supply, can be connected to J4. The LCD module can only support these panels as well.

Header, J4, and its associated buffers and components have been left unpopulated on the CPU module. These parts can be added by the user if desired.

## 4.3 LCD Controller

### 4.3.1 S1D13704 vs. S1D13705

The LCD controller used in conjunction with the TMPR3912/22U microprocessor can either be a S1D13704 or a S1D13705. If a S1D13704 is used, jumper JP7 must be set to position 1 2. This setting allows CNF4 to be configured for the S1D13704. CNF4 controls the polarity of the LCDPWR signal and can be set either high or low with jumper, JP11. If a S1D13705 is used, jumper JP7 must be set to position 2 3. This setting allows pin 45 of the LCDC to be used as address bit, AB16, which is needed on the S1D13705 to accommodate the larger display memory.

### 4.3.2 LCDPWR Polarity

The power supply on the LCD module used LCDON, an active low signal to turn on the supply. This signal is connected to LCDPWR. Since LCDPWR is configurable on the S1D13704 and is set active high on the S1D13705, a facility must be provided to invert this signal if it is active high so that LCDON will be the right polarity to turn on the LCD power supply. Jumper, JP10 must be set to position 1 2 if LCDPWR is active low and to position 2 3 if LCDPWR is active high.

### 4.3.3 S1D13704/5 Chip Select

Minimal glue logic is used on the CPU module to provide the chip select signal, CS#, for the LCDC. A simple AND gate activates the S1D13704/5 whenever the PC Card slot #1 is accessed, whether it be memory space or attribute space.

**THIS PAGE LEFT BLANK**



# EPSON®



## S1D13705 Embedded Memory LCD Controller

# Interfacing to the NEC VR4181A™ Microprocessor

Document Number: X27A-G-013-02

Copyright © 2001 Epson Research and Development, Inc. All Rights Reserved.

Information in this document is subject to change without notice. You may download and use this document, but only for your own use in evaluating Seiko Epson/EPSON products. You may not modify the document. Epson Research and Development, Inc. disclaims any representation that the contents of this document are accurate or current. The Programs/Technologies described in this document may contain material protected under U.S. and/or International Patent laws.

EPSON is a registered trademark of Seiko Epson Corporation. All Trademarks are the property of their respective owners.

---

**THIS PAGE LEFT BLANK**

# Table of Contents

<b>1</b>	<b>Introduction</b>	<b>7</b>
<b>2</b>	<b>Interfacing to the NEC VR4181A</b>	<b>8</b>
2.1	The NEC VR4181A System Bus	8
2.1.1	Overview	8
2.1.2	LCD Memory Access Signals	9
<b>3</b>	<b>S1D13705 Host Bus Interface</b>	<b>10</b>
3.1	Host Bus Pin Connection	10
3.2	Generic #2 Interface Mode	11
<b>4</b>	<b>VR4181A to S1D13705 Interface</b>	<b>12</b>
4.1	Hardware Description	12
4.2	S1D13705 Hardware Configuration	13
4.3	NEC VR4181A Configuration	14
<b>5</b>	<b>Software</b>	<b>15</b>
<b>6</b>	<b>References</b>	<b>16</b>
6.1	Documents	16
6.2	Document Sources	16
<b>7</b>	<b>Technical Support</b>	<b>17</b>
7.1	Epson LCD Controllers (S1D13705)	17
7.2	NEC Electronics Inc.	17

**THIS PAGE LEFT BLANK**

---

## List of Tables

Table 3-1: Host Bus Interface Pin Mapping . . . . .	10
Table 4-1: Summary of Power-On/Reset Options . . . . .	13
Table 4-2: Host Bus Selection . . . . .	13

## List of Figures

Figure 4-1: Typical Implementation of VR4181A to S1D13705 Interface . . . . .	12
---	----

**THIS PAGE LEFT BLANK**

# 1 Introduction

This application note describes the hardware required to interface the S1D13705 Embedded Memory LCD Controller and the NEC VR4181A microprocessor. The NEC VR4181A microprocessor is specifically designed to support an external LCD controller and the pairing of these two devices results in an embedded system offering impressive display capability with very low power consumption.

The designs described in this document are presented only as examples of how such interfaces might be implemented. This application note will be updated as appropriate. Please check the Epson Electronics America website at <http://www.eea.epson.com> for the latest revision of this document before beginning any development.

We appreciate your comments on our documentation. Please contact us via email at [techpubs@erd.epson.com](mailto:techpubs@erd.epson.com).

## 2 Interfacing to the NEC VR4181A

### 2.1 The NEC VR4181A System Bus

The VR-Series family of microprocessors features a high-speed synchronous system bus typical of modern microprocessors. Designed with external LCD controller support and Windows CE based embedded consumer applications in mind, the VR4181A offers a highly integrated solution for portable systems. This section is an overview of the operation of the CPU bus to establish interface requirements.

#### 2.1.1 Overview

The NEC VR4181A is designed around the RISC architecture developed by MIPS. This microprocessor is designed around the 100MHz VR4110 CPU core which supports the MIPS III and MIPS16 instruction sets. The CPU communicates with external devices via an ISA interface.

The NEC VR4181A has direct support for an external LCD controller. A 64 to 512-kilobyte block of memory is assigned to the LCD controller with a dedicated chip select signal. Word or byte accesses are controlled by the system high byte signal, #UBE.



## 2.1.2 LCD Memory Access Signals

The S1D13705 requires an addressing range of 128Kbytes. When the VR4181A's external LCD controller chip select signal is programmed to a window of that size, the S1D13705 must reside in the VR4181A physical address range of 133E 0000h to 133F FFFFh which is part of the external ISA memory space.

The signals required for external LCD controller access are listed below and obey ISA signalling rules.

- A[16:0]                      Address bus
- #UBE                        High byte enable (active low)
- #LCDCS                    LCD controller (S1D13705) chip select (active low)
- D[15:0]                    Data bus
- #MEMRD                  Read command (active low)
- #MEMWR                  Write command (active low)
- #MEMCS16                Sixteen-bit peripheral capability acknowledge (active low)
- IORDY                     Ready signal from S1D13705
- SYSCLK                    Optional, prescalable bus clock

Once an address in the LCD block of memory is accessed, the LCD chip select #LCDCS is driven low. The read or write enable signals, #MEMRD or #MEMWR, are driven low for the appropriate cycle and IORDY is driven low by the S1D13705 to insert wait states into the cycle. The high byte enable is driven low for 16-bit transfers and high for 8-bit transfers.

## 3 S1D13705 Host Bus Interface

This section is a summary of the host bus interface modes available on the S1D13705 that would be used to interface to the VR4181A.

The S1D13705 implements a 16-bit interface to the host microprocessor which may operate in one of several modes compatible with most of the popular embedded microprocessor families. The interface mode used for the VR4181A is:

- Generic #2 (External Chip Select, shared Read/Write Enable for high byte, individual Read/Write Enable for low byte).

### 3.1 Host Bus Pin Connection

Table 3-1: Host Bus Interface Pin Mapping

S1D13705 Pin Names	Generic #2
AB[16:1]	A[16:1]
AB0	A0
DB[15:0]	D[15:0]
WE1#	BHE#
CS#	External Decode
BCLK	BCLK
BS#	Connect to IO $V_{DD}$
RD/WR#	Connect to IO $V_{DD}$
RD#	RD#
WE0#	WE#
WAIT#	WAIT#
RESET#	RESET#

For details on configuration, refer to the *S1D13705 Hardware Functional Specification*, document number X27A-A-001-xx.

## 3.2 Generic #2 Interface Mode

Generic #2 interface mode is a general and non-processor-specific interface mode on the S1D13705. The Generic # 2 interface mode was chosen for this interface due to the simplicity of its timing and compatibility with the VR4181A control signals.

The interface requires the following signals:

- BUSCLK is a clock input which synchronizes transfers between the host CPU and the S1D13705. It is separate from the input clock (CLKI) and is typically driven by the host CPU system clock.
- The address inputs AB0 through AB16, and the data bus DB0 through DB15, connect directly to the CPU address and data bus, respectively. On 32-bit big endian architectures such as the Power PC, the data bus would connect to the high-order data lines; on little endian hosts, or 16-bit big endian hosts, they would connect to the low-order data lines. The hardware engineer must ensure that CNF3 selects the proper endian mode upon reset.
- Chip Select (CS#) is driven by decoding the high-order address lines to select the proper register and memory address space.
- WE1# is the high byte enable for both read and write cycles.
- WE0# is the write enable signal for the S1D13705, to be driven low when the host CPU is writing data from the S1D13705.
- RD# is the read enable for the S1D13705, to be driven low when the host CPU is reading data from the S1D13705.
- WAIT# is a signal which is output from the S1D13705 to the host CPU that indicates when data is ready (read cycle) or accepted (write cycle) on the host bus. Since host CPU accesses to the S1D13705 may occur asynchronously to the display update, it is possible that contention may occur in accessing the S1D13705 internal registers or memory. The WAIT# line resolves these contentions by forcing the host to wait until the resource arbitration is complete. This signal is active low and may need to be inverted if the host CPU wait state signal is active high.
- The Bus Status (BS#) and Read/Write (RD/WR#) signals are not used in the bus interface for Generic #2 mode. However, BS# is used to configure the S1D13705 for Generic #2 mode and should be tied high (connected to IOV<sub>DD</sub>). RD/WR# should also be tied high.

## 4 VR4181A to S1D13705 Interface

### 4.1 Hardware Description

The NEC VR4181A microprocessor is specifically designed to support an external LCD controller by providing the internal address decoding and control signals necessary. By using the Generic # 2 interface, a glueless interface is achieved. The diagram below shows a typical implementation of the VR4181A to S1D13705 interface.

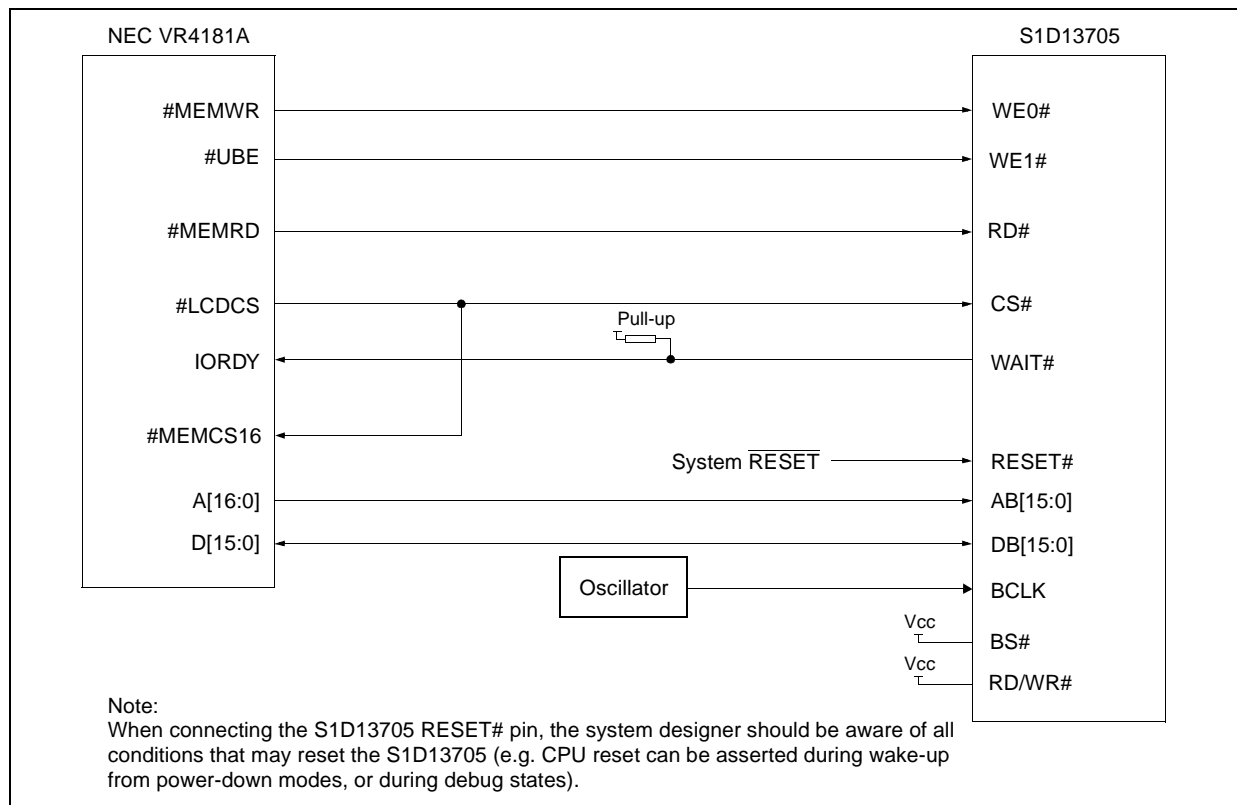

Figure 4-1: Typical Implementation of VR4181A to S1D13705 Interface

The host interface control signals of the S1D13705 are asynchronous with respect to the S1D13705 bus clock. This gives the system designer full flexibility to choose the appropriate source (or sources) for CLKI and BCLK. The choice of whether both clocks should be the same, and whether an external or internal clock divider is needed, should be based on the desired:

- pixel and frame rates.
- power budget.
- part count.
- maximum S1D13705 clock frequencies.

The S1D13705 also has internal clock dividers providing additional flexibility.

## 4.2 S1D13705 Hardware Configuration

The S1D13705 uses CNF3 through CNF0 and BS# to allow selection of the bus mode and other configuration data on the rising edge of RESET#. Refer to the *S1D13705 Hardware Functional Specification*, document number X27A-A-001-xx for details.

The tables below show those configuration settings important to the Generic #2 host bus interface.

*Table 4-1: Summary of Power-On/Reset Options*

Signal	value on this pin at the rising edge of RESET# is used to configure: (0/1)	
	0	1
CNF0	See "Host Bus Selection" table below	See "Host Bus Selection" table below
CNF1		
CNF2		
CNF3	Little Endian	Big Endian

= configuration for NEC VR4181A support

*Table 4-2: Host Bus Selection*

CNF2	CNF1	CNF0	BS#	Host Bus Interface
1	1	1	1	Generic #2, 16-bit

= configuration for NEC VR4181A support

### 4.3 NEC VR4181A Configuration

The NEC VR4181A must be configured through its internal registers in order to map the S1D13705 to the external LCD controller space. The following register values must be set.

Register LCDGPMD at address 0B00 032Eh must be set as follows.

- Bit 7 must be set to 1 to disable the internal LCD controller and enable the external LCD controller interface. This also maps pin SHCLK to #LCDCS and pin LOCLK to #MEMCS16.
- Bits [1:0] must be set to 01b to reserve 128Kbytes of memory address range 133E 0000h to 133F FFFFh for the external LCD controller.

Register GPMD2REG at address 0B00 0304h must be set as follows.

- Bits [9:8] (GP20MD[1:0]) must be set to 11b to map pin GPIO20 to #UBE.
- Bits [5:4] (GP18MD[1:0]) must be set to 01b to map pin GPIO18 to IORDY.

## 5 Software

Test utilities and Windows® CE v2.0 display drivers are available for the S1D13705. Full source code is available for both the test utilities and the drivers.

The test utilities are configurable for different panel types using a program called 13705CFG, or by directly modifying the source. The Windows CE v2.0 display drivers can be customized by the OEM for different panel types, resolutions and color depths only by modifying the source.

The S1D13705 test utilities and Windows CE v2.0 display drivers are available from your sales support contact or on the internet at <http://www.eea.epson.com>.

## 6 References

### 6.1 Documents

- NEC VR4181A Target Specification, Revision 0.5, 9/11/98
- Epson Research and Development, Inc., *S1D13705 Hardware Functional Specification*; Document Number X27A-A-002-xx.
- Epson Research and Development, Inc., *S5U13705B00C Rev. 1.0 ISA Bus Evaluation Board User Manual*; Document Number X27A-G-005-xx.
- Epson Research and Development, Inc., *S1D13705 Programming Notes and Examples*; Document Number X27A-G-002-xx.

### 6.2 Document Sources

- NEC website at <http://www.nec.com>.
- Epson Electronics America website at <http://www.eea.epson.com>



## 7 Technical Support

### 7.1 Epson LCD Controllers (S1D13705)

#### Japan

Seiko Epson Corporation  
Electronic Devices Marketing Division  
421-8, Hino, Hino-shi  
Tokyo 191-8501, Japan  
Tel: 042-587-5812  
Fax: 042-587-5564  
<http://www.epson.co.jp>

#### North America

Epson Electronics America, Inc.  
150 River Oaks Parkway  
San Jose, CA 95134, USA  
Tel: (408) 922-0200  
Fax: (408) 922-0238  
<http://www.eea.epson.com>

#### Taiwan, R.O.C.

Epson Taiwan Technology  
& Trading Ltd.  
10F, No. 287  
Nanking East Road  
Sec. 3, Taipei, Taiwan, R.O.C.  
Tel: 02-2717-7360  
Fax: 02-2712-9164

#### Hong Kong

Epson Hong Kong Ltd.  
20/F., Harbour Centre  
25 Harbour Road  
Wanchai, Hong Kong  
Tel: 2585-4600  
Fax: 2827-4346

#### Europe

Epson Europe Electronics GmbH  
Riesstrasse 15  
80992 Munich, Germany  
Tel: 089-14005-0  
Fax: 089-14005-110

#### Singapore

Epson Singapore Pte., Ltd.  
No. 1  
Temasek Avenue #36-00  
Millenia Tower  
Singapore, 039192  
Tel: 337-7911  
Fax: 334-2716

### 7.2 NEC Electronics Inc.

#### NEC Electronics Inc. (U.S.A.)

Santa Clara  
California  
Tel: (800) 366-9782  
Fax: (800) 729-9288  
<http://www.nec.com>

**THIS PAGE LEFT BLANK**

# EPSON®



## S1D13705 Embedded Memory Color LCD Controller

# Interfacing to an 8-bit Processor

Document Number: X27A-G-015-01

Copyright © 2001 Epson Research and Development, Inc. All Rights Reserved.

Information in this document is subject to change without notice. You may download and use this document, but only for your own use in evaluating Seiko Epson/EPSON products. You may not modify the document. Epson Research and Development, Inc. disclaims any representation that the contents of this document are accurate or current. The Programs/Technologies described in this document may contain material protected under U.S. and/or International Patent laws.

EPSON is a registered trademark of Seiko Epson Corporation. All Trademarks are the property of their respective owners.

---

**THIS PAGE LEFT BLANK**

# Table of Contents

<b>1</b>	<b>Introduction</b>	<b>7</b>
<b>2</b>	<b>Interfacing to an 8-bit Processor</b>	<b>8</b>
2.1	The Generic 8-bit Processor System Bus	8
<b>3</b>	<b>S1D13705 Bus Interface</b>	<b>9</b>
3.1	Host Bus Pin Connection	9
3.2	Generic #2 Interface Mode	10
<b>4</b>	<b>8-Bit Processor to S1D13705 Interface</b>	<b>11</b>
4.1	Hardware Description	11
4.2	S1D13705 Hardware Configuration	12
4.3	Register/Memory Mapping	12
<b>5</b>	<b>Software</b>	<b>13</b>
<b>6</b>	<b>References</b>	<b>14</b>
6.1	Documents	14
6.2	Document Sources	14
<b>7</b>	<b>Technical Support</b>	<b>15</b>
7.1	Epson LCD/CRT Controllers (S1D13705)	15

**THIS PAGE LEFT BLANK**

---

## List of Tables

Table 3-1: Host Bus Interface Pin Mapping . . . . .	9
Table 4-1: Configuration Settings . . . . .	12
Table 4-2: Host Bus Selection . . . . .	12

## List of Figures

Figure 4-1: Typical Implementation of an 8-bit Processor to the S1D13705 Generic #2 Interface . . .	11
---	----

**THIS PAGE LEFT BLANK**



---

# 1 Introduction

This application note describes the hardware environment required to provide an interface between the S1D13705 Embedded Memory LCD Controller and a generic 8-bit microprocessor.

The designs described in this document are presented only as examples of how such interfaces might be implemented. This application note will be updated as appropriate. Please check the Epson Research and Development Website at <http://www.erd.epson.com> for the latest revision of this document before beginning any development.

We appreciate your comments on our documentation. Please contact us via email at [documentation@erd.epson.com](mailto:documentation@erd.epson.com).

## 2 Interfacing to an 8-bit Processor

### 2.1 The Generic 8-bit Processor System Bus

Although the S1D13705 does not directly support an 8-bit CPU, with minimal external logic an 8-bit interface can be achieved.

Typically, the bus of an 8-bit microprocessor is straight forward with minimal CPU and system control signals. To connect a memory mapped device such as the S1D13705, only the write, read, and wait control signals, as well as the data and address lines, need to be interfaced. Since the S1D13705 is a 16-bit device, some external logic is required.

## 3 S1D13705 Bus Interface

This section is a summary of the host bus interface modes available on the S1D13705 and offers some detail on the Generic #2 Host Bus Interface used to implement the interface to an 8-bit processor.

The S1D13705 provides a 16-bit interface to the host microprocessor which may operate in one of several modes compatible with most of the popular embedded microprocessor families. The bus interface mode used in this example is:

- Generic #2 (this bus interface is ISA-like and can easily be modified to support an 8-bit CPU).

### 3.1 Host Bus Pin Connection

The following table shows the functions of each host bus interface signal.

*Table 3-1: Host Bus Interface Pin Mapping*

S1D13705 Pin Names	Generic #2	Description
AB[16:1]	A[16:1]	Address [16:1]
AB0	A0	Address A0
DB[15:0]	D[15:0]	Data
WE1#	BHE#	Byte High Enable
CS#	External Decode	Chip Select
BCLK	BCLK	Bus Clock
BS#	n/c	Must be tied to IO V <sub>DD</sub>
RD/WR#	n/c	Must be tied to IO V <sub>DD</sub>
RD#	RD#	Read
WE0#	WE#	Write
WAIT#	WAIT#	
RESET#	RESET#	

#### Note

If the CPU does not have address A16 all 80K Bytes of embedded memory will not be accessible.

For details on configuration, refer to the *S1D13705 Hardware Functional Specification*, document number X27A-A-001-xx.

## 3.2 Generic #2 Interface Mode

Generic #2 Host Bus Interface is a general, non-processor specific interface mode on the S1D13705 that is ideally suited to interface to an 8-bit processor bus.

The interface requires the following signals:

- BUSCLK is a clock input which synchronizes transfers between the host CPU and the S1D13705. It is separate from the input clock (CLKI) and is typically driven by the host CPU system clock. If the host CPU bus does not provide this clock, an asynchronous clock can be provided.
- The address inputs AB0 through AB16, and the data bus DB0 through DB15, connect directly to the CPU address and data bus, respectively.

### Note

In an 8-bit environment D[7:0] must also be connected to DB[15:8] respectively (i.e. D7 connects to both DB15 and DB7, D6 connects to both DB14 and DB6, D5 connects to both DB13 and DB5, etc.). See Figure 4-1: “Typical Implementation of an 8-bit Processor to the S1D13705 Generic #2 Interface” .

- Chip Select (CS#) is driven by decoding the high-order address lines to select the proper memory address space.
- BHE# (WE1#) is the high byte enable for both read and write cycles.

### Note

In an 8-bit environment, this signal is driven by inverting address line A0 thus indicating that odd addresses are to be R/W on the high byte of the data bus.

- WE0# is the enable signal for a write access, to be driven low when the host CPU is writing the 1375 memory or registers.
- RD# is the read enable for the S1D13705, to be driven low when the host CPU is reading data from the S1D13705.
- WAIT# is a signal which is output from the S1D13705 to the host CPU that indicates when data is ready (read cycle) or accepted (write cycle) on the host bus. Since host CPU accesses to the S1D13705 may occur asynchronously to the display update, it is possible that contention may occur in accessing the 1375 internal registers and/or refresh memory. The WAIT# line resolves these contentions by forcing the host to wait until the resource arbitration is complete. This signal is active low and may need to be inverted if the host CPU wait state signal is active high.
- The Bus Status (BS#) and Read/Write (RD/WR#) signals are not used in the bus interface for Generic #2 mode. However, BS# is used to configure the S1D13705 for Generic #2 mode and should be tied high (connected to IO  $V_{DD}$ ). RD/WR# should also be tied high.

## 4 8-Bit Processor to S1D13705 Interface

### 4.1 Hardware Description

The interface between the S1D13705 and an 8-bit processor requires minimal glue logic. A decoder is used to generate the chip select for the S1D13705 based on where the S1D13705 is mapped into memory. Alternatively, if the processor supports a chip select module, it can be programmed to generate a chip select for the S1D13705 without the need of an address decoder.

An inverter inverts A0 to generate the Byte High Enable signal for the S1D13705. If the 8-bit host interface has an active high WAIT signal, it must be inverted as well.

In order to support an 8-bit microprocessor with a 16-bit peripheral, the low and high order bytes of the data bus must be connected together. The following diagram shows a typical implementation of an 8-bit processor interfaced to the S1D13705.

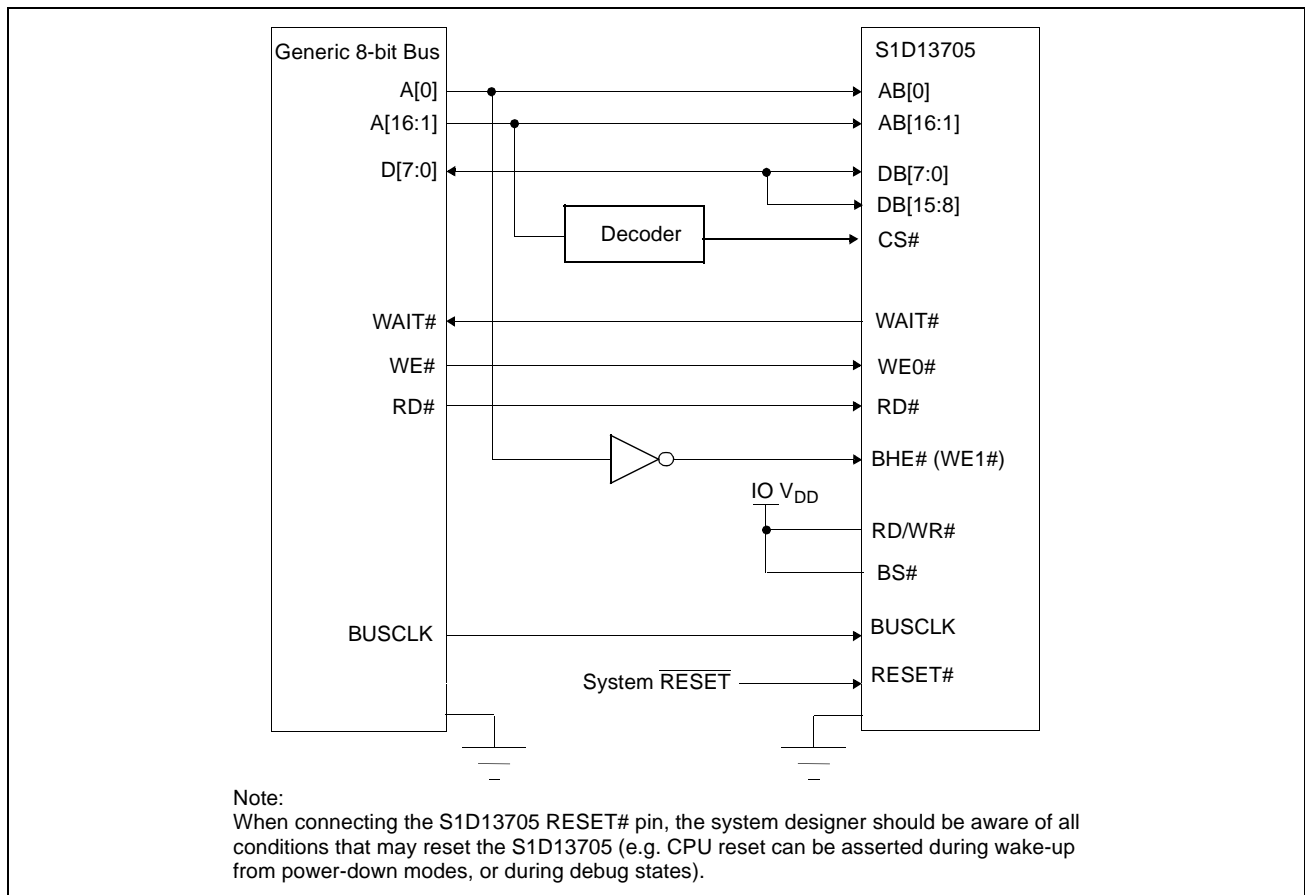

Figure 4-1: Typical Implementation of an 8-bit Processor to the S1D13705 Generic #2 Interface

## 4.2 S1D13705 Hardware Configuration

The S1D13705 uses CNF4 through CNF0 and BS# to allow selection of the bus mode and other configuration data on the rising edge of RESET#. Refer to the *S1D13705 Hardware Functional Specification*, document number X27A-A-001-xx for details.

The tables below show only those configuration settings important to the 8-bit processor interface. The endian must be selected based on the 8-bit processor used.

*Table 4-1: Configuration Settings*

Signal	Low	High
CNF0	See "Host Bus Selection" table below	See "Host Bus Selection" table below
CNF1		
CNF2		
CNF3	Little Endian	Big Endian
CNF4	Active low LCDPWR signal	Active high LCDPWR signal
	= configuration for 8-bit processor host bus interface	

*Table 4-2: Host Bus Selection*

CNF2	CNF1	CNF0	BS#	Host Bus Interface
1	1	1	1	Generic #2, 16-bit
	= required configuration for this application.			

## 4.3 Register/Memory Mapping

The S1D13705 needs a 128K byte block of memory to accommodate its 80K byte display buffer and its 32 byte register set. The starting memory address is located at 00000h of the 128K byte memory block while the internal registers are located in the upper 32 bytes of this memory block. (i.e. REG[0]= 1FFE0h).

An external decoder can be used to decode the address lines and generate a chip select for the S1D13705 whenever the selected 128K byte memory block is accessed. If the processor supports a general chip select module, its internal registers can be programmed to generate a chip select for the S1D13705 whenever the S1D13705 memory block is accessed.

---

## 5 Software

Test utilities and display drivers are available for the S1D13705. Full source code is available for both the test utilities and the drivers.

The test utilities are configurable for different panel types using a program called 13705CFG. The display drivers can be customized by the OEM for different panel types, resolutions and color depths only by modifying the source.

The S1D13705 test utilities and display drivers are available from your sales support contact or on the internet at <http://www.erd.epson.com>.

## 6 References

### 6.1 Documents

- Epson Research and Development, Inc., *S1D13705 Embedded Memory LCD Controller Hardware Functional Specification*; Document Number X27A-A-002-xx.
- Epson Research and Development, Inc., *S5U13705B00C Rev. 1.0 ISA Bus Evaluation Board User Manual*; Document Number X26A-G-005-xx.
- Epson Research and Development, Inc., *S1D13705 Programming Notes and Examples*; Document Number X26A-G-002-xx.

### 6.2 Document Sources

- Epson Research and Development Website: <http://www.eea.epson.com>.



## 7 Technical Support

### 7.1 Epson LCD/CRT Controllers (S1D13705)

#### Japan

Seiko Epson Corporation  
Electronic Devices Marketing Division  
421-8, Hino, Hino-shi  
Tokyo 191-8501, Japan  
Tel: 042-587-5812  
Fax: 042-587-5564  
<http://www.epson.co.jp/>

#### North America

Epson Electronics America, Inc.  
150 River Oaks Parkway  
San Jose, CA 95134, USA  
Tel: (408) 922-0200  
Fax: (408) 922-0238  
<http://www.eea.epson.com/>

#### Taiwan

Epson Taiwan Technology  
& Trading Ltd.  
10F, No. 287  
Nanking East Road  
Sec. 3, Taipei, Taiwan  
Tel: 02-2717-7360  
Fax: 02-2712-9164  
<http://www.epson.com.tw/>

#### Hong Kong

Epson Hong Kong Ltd.  
20/F., Harbour Centre  
25 Harbour Road  
Wanchai, Hong Kong  
Tel: 2585-4600  
Fax: 2827-4346  
<http://www.epson.com.hk/>

#### Europe

Epson Europe Electronics GmbH  
Riesstrasse 15  
80992 Munich, Germany  
Tel: 089-14005-0  
Fax: 089-14005-110  
<http://www.epson-electronics.de/>

#### Singapore

Epson Singapore Pte., Ltd.  
No. 1  
Temasek Avenue #36-00  
Millenia Tower  
Singapore, 039192  
Tel: 337-7911  
Fax: 334-2716  
<http://www.epson.com.sg/>

**THIS PAGE LEFT BLANK**

## Данный компонент на территории Российской Федерации

### Вы можете приобрести в компании MosChip.

Для оперативного оформления запроса Вам необходимо перейти по данной ссылке:

<http://moschip.ru/get-element>

Вы можете разместить у нас заказ для любого Вашего проекта, будь то серийное производство или разработка единичного прибора.

В нашем ассортименте представлены ведущие мировые производители активных и пассивных электронных компонентов.

Нашей специализацией является поставка электронной компонентной базы двойного назначения, продукции таких производителей как XILINX, Intel (ex.ALTERA), Vicor, Microchip, Texas Instruments, Analog Devices, Mini-Circuits, Amphenol, Glenair.

Сотрудничество с глобальными дистрибьюторами электронных компонентов, предоставляет возможность заказывать и получать с международных складов практически любой перечень компонентов в оптимальные для Вас сроки.

На всех этапах разработки и производства наши партнеры могут получить квалифицированную поддержку опытных инженеров.

Система менеджмента качества компании отвечает требованиям в соответствии с ГОСТ Р ИСО 9001, ГОСТ РВ 0015-002 и ЭС РД 009

### Офис по работе с юридическими лицами:

105318, г.Москва, ул.Щербаковская д.3, офис 1107, 1118, ДЦ «Щербаковский»

Телефон: +7 495 668-12-70 (многоканальный)

Факс: +7 495 668-12-70 (доб.304)

E-mail: [info@moschip.ru](mailto:info@moschip.ru)

Skype отдела продаж:

moschip.ru

moschip.ru\_4

moschip.ru\_6

moschip.ru\_9