

## PARALLEL ABSOLUTE MULTITURN ENCODER - PUSH PULL - PHM5 RANGE

- Solid shaft  $\varnothing 6$  and  $\varnothing 10$  mm,
- Robustness and excellent resistance to shocks / vibrations,
- High protection level IP65, IP67 option with a sealing flange,
- High performances in temperature  $-20^{\circ}\text{C}$  to  $+85^{\circ}\text{C}$ ,
- Parallel output – push pull electronic,
- Universal electronic circuits from 5 to 30Vdc,
- Protection against short-circuits and inversion of polarity,
- High resolutions available: 8192 (13 bits) per turn,
- Turn counting up to 65 536 (16 bits),
- Reset, Select, Latch, Direction functions,
- Option: push-button on the cover for an encoder reset to a value X.

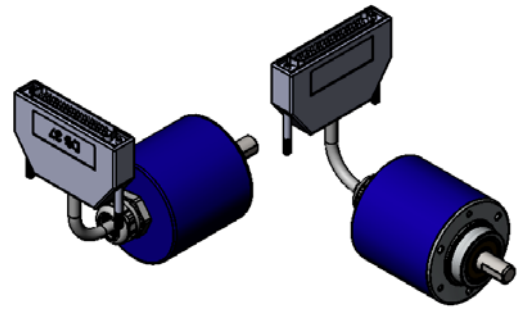

### PHM5 PARALLEL DIMENSIONS

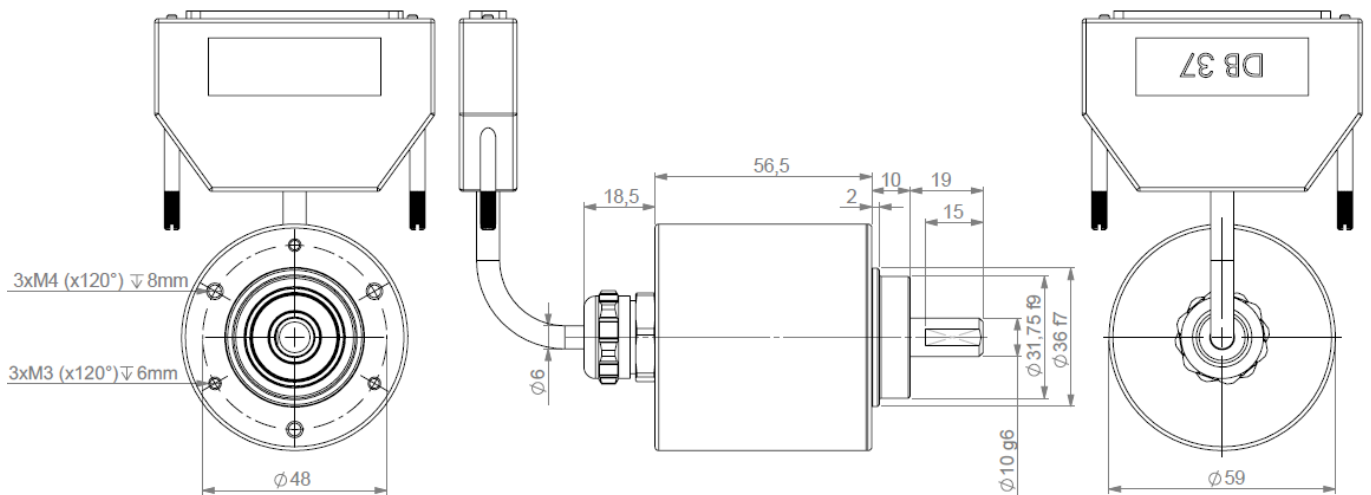

### MECHANICAL CHARACTERISTICS

Material	Cover : steel	Shock (EN60068-2-27)	$\leq 500 \text{ m.s}^{-2}$ (during 6 ms)
	Body: aluminium	Vibration (EN60068-2-6)	$\leq 100 \text{ m.s}^{-2}$ (10... 2 000 Hz)
	Shaft : stainless steel	EMC	EN 61000-6-4, EN 61000-6-2
Bearings	6 000 serie	Isolation	100V (1 min.)
Maximum load	Axial : 50 N	Weight (connector)	0,750 kg
	Radial : 100 N	Operating temperature	$-20 \dots +85^{\circ}\text{C}$ (encoder T°)
Shaft inertia	$\leq 1.10^{-6} \text{ kg.m}^2$	Storage temperature	$-20 \dots +85^{\circ}\text{C}$
Torque	$\leq 4.10^{-3} \text{ N.m}$	Protection(EN 60529)	IP 65 (IP67 with flange option)
Permissible max. speed	6 000 $\text{min}^{-1}$	Theoretical mechanical lifetime $10^9$ turns ( $F_{axial} / F_{radial}$ )	
Continuous max. speed	6 000 $\text{min}^{-1}$	25 N / 50 N : 99	50 N / 100 N : 12

### SCHEMES

#### LATCH input

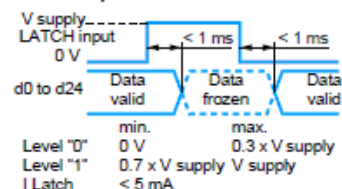

#### DIRECTION input

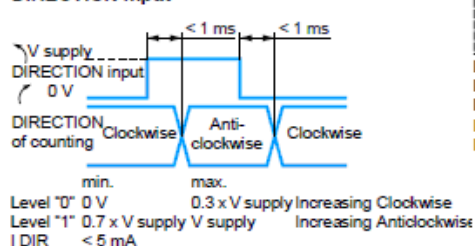

#### PUSH-PULL

Supply: 5 to 30 V  $\pm$   
Max. ripple: 500 mV  
Protection against reverse polarity  
Max. no-load consumption: 100 mA (50 mA typical on 24 V)

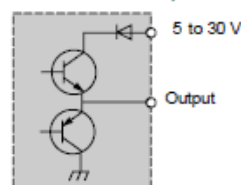

Max. current: 20 mA  
Level "0" max.: 0.5 V  
Level "1" min.: V supply - 2.5 V  
Protection against short-circuits  
NPN/PNP compatible

#### SELECT input

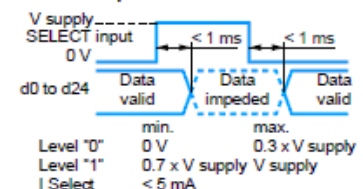

#### Input stage - Reset to zero

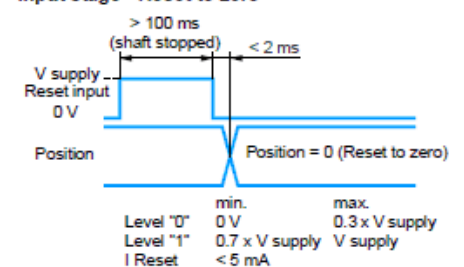

## PARALLEL ABSOLUTE MULTITURN ENCODER – PUSH PULL - PHM5 RANGE

### ELECTRONIC

Power supply	5 – 30Vdc
Introduction	< 1 s
Cons. without load	< 100mA (typically 50-60mA at 24Vdc)
Position refresh	< 200µs

### PARALLEL CONNECTION

1	GN green	Output Bit 0
2	YE yellow	Output Bit 1
3	GY grey	Output Bit 2
4	PK pink	Output Bit 3
5	BU blue	Output Bit 4
6	RD red	Output Bit 5
7	BK black	Output Bit 6
8	VT violet	Output Bit 7
9	WH/BN white/brown	Output Bit 8
10	WH/GN white/green	Output Bit 9
11	WH/YE white/yellow	Output Bit 10
12	WH/GY white/grey	Output Bit 11
13	WH/PK white/pink	Output Bit 12
14	WH/BU white/blue	Output Bit 13
15	WH/RD white/red	Output Bit 14
16	WH/BK white/black	Output Bit 15
17	BN/GN brown/green	Output Bit 16
18	BN/YE brown/yellow	Output Bit 17
19	BN/GY brown/grey	Output Bit 18

20	BN/PK brown/pink	Output Bit 19
21	BN/BU brown/blue	Output Bit 20
22	BN/RD brown/red	Output Bit 21
23	BN/BK brown/black	Output Bit 22
24	GN/GY green/grey	Output Bit 23
25	GN/PK green/pink	Output Bit 24
26	GN/BU green/blue	Reserved
27	GN/RD green/red	RESET
28	GN/BK green/black	SELECT
29	YE/GY yellow/grey	LATCH
30	YE/PK yellow/pink	DIRECTION
31	YE/BU yellow/blue	Reserved
32	YE/RD yellow/red	Reserved
33	NC	Reserved
34	YE/BK yellow/black	Reserved
35	RD/BK red/black	Reserved
36	BN brown	5 to 30Vdc
37	WH white	0 Vdc

#### SELECT

Active data output, pin SELECT at 0Vdc  
Non active data output: pin select to +Vcc

#### LATCH

Active data: pin LATCH to 0Vdc  
Data frozen: pin LATCH to +Vcc

DIRECTION, LATCH, RAX and SELECT inputs have to be connected to 0Vdc or +Vcc (LATCH, SELECT and RAX at 0V if not used)  
Reserved: Do not connect !

Example of pin assignment for configuration 10x7 bits : data available on pin 1 to 17 - Max: 25 bits (Resolution + Number of turns)

#### DIRECTION

Increasing code clockwise: pin DIRECTION at 0Vdc  
Increasing code counter clockwise: Pin DIRECTION at +Vcc

#### RAX (PRESET to X):

For an electrical RAX (or push-button option) : pin RAX to +Vcc during minimum 100ms.

### ORDERING REFERENCE (Contact the factory for special versions, ex: special flanges, connections, electronics...)

	Shaft Ø	Supply	Output stage	Code	Resolution	Number of turns	Connection	Orientation
PHM5	10 :	P :	S5 :	G :	13 :	B12	S3	A010 :
	10mm							
	06 :			B :	Nota: Available form 0 to 13 bits	Nota: Available form 0 to 16 bits		
	6mm			Binary		Max: 25 bits (Resolution + Number of turns)		
PHM5_	10 //	P	S5	G //	13	B12 //	S3	A010

Made in France

## Данный компонент на территории Российской Федерации

### Вы можете приобрести в компании MosChip.

Для оперативного оформления запроса Вам необходимо перейти по данной ссылке:

<http://moschip.ru/get-element>

Вы можете разместить у нас заказ для любого Вашего проекта, будь то серийное производство или разработка единичного прибора.

В нашем ассортименте представлены ведущие мировые производители активных и пассивных электронных компонентов.

Нашей специализацией является поставка электронной компонентной базы двойного назначения, продукции таких производителей как XILINX, Intel (ex.ALTERA), Vicor, Microchip, Texas Instruments, Analog Devices, Mini-Circuits, Amphenol, Glenair.

Сотрудничество с глобальными дистрибьюторами электронных компонентов, предоставляет возможность заказывать и получать с международных складов практически любой перечень компонентов в оптимальные для Вас сроки.

На всех этапах разработки и производства наши партнеры могут получить квалифицированную поддержку опытных инженеров.

Система менеджмента качества компании отвечает требованиям в соответствии с ГОСТ Р ИСО 9001, ГОСТ РВ 0015-002 и ЭС РД 009

### Офис по работе с юридическими лицами:

105318, г.Москва, ул.Щербаковская д.3, офис 1107, 1118, ДЦ «Щербаковский»

Телефон: +7 495 668-12-70 (многоканальный)

Факс: +7 495 668-12-70 (доб.304)

E-mail: [info@moschip.ru](mailto:info@moschip.ru)

Skype отдела продаж:

moschip.ru

moschip.ru\_4

moschip.ru\_6

moschip.ru\_9