

LTC6412  
800MHz, 31dB Range  
Analog-Controlled VGA

## DESCRIPTION

Demonstration circuit 1464 features the LTC6412 analog-controlled VGA. The demo board incorporates a variety of passive components to allow for direct connection to a 2-port network analyzer or other single-ended 50Ω test system for simplified evaluation.

The 1464 demo board factory default configuration is set for  $-V_G$  control mode in the power-on and amplifier-enabled state ( $\overline{\text{SHDN}}=1$ ,  $\overline{\text{EN}}=0$ ).

The demo board is easily configured to access the  $+V_G$  control mode and  $\overline{\text{EN}}/\overline{\text{SHDN}}$  features. Other simple PCB modifications can accommodate differential input/output signals and shunt tuning elements for bread-boarding into larger systems.

**Design files for this circuit board are available. Call the LTC factory.**

 LTC, LTM, and LT are trademarks of Linear Technology Corporation. Other product names may be trademarks of the companies that manufacture the products.

---

## QUICK START PROCEDURE

Demonstration circuit 1464 is easy to set up to evaluate the performance of the LTC6412. Refer to Figure 1 for proper measurement equipment setup and follow the procedure below:

1. Connect SMA cables to the +IN and +OUT ports. Applied signal should be less than +10dBm peak RF power to avoid damage in the power-off state.
2. Apply +3.3V between  $+V_{CC}$  and GND turrets. Limit supply current to approximately 150mA.
3. Apply the desired control signal to either the  $-V_G$  turret or the  $-V_G$  SMA to access the  $-V_G$  pin of the LTC6412. For this  $-V_G$  control mode, an *increase* in control signal voltage produces a *decrease* in amplifier gain.

This procedure contains only one critical sequence order. The user must apply supply voltage before applying the control signal voltage and remove or turn-down the control signal voltage before turning down the supply voltage. This proper sequence will prevent excessive current through the ESD diodes from the  $\pm V_G$  pins to the positive supply,  $V_{CC}$ .

Table 1 shows the function of each SMA connector on the board. Only J1 and J2 are used in the default evaluation configuration. Other connectors provide flexibility for fast control signals, differential input/output signals, and balun loss calibration.

# DEMO CIRCUIT DC1464 QUICK START GUIDE FOR LTC6412

Table 1. DC1464 SMA Connector Descriptions

CONNECTOR	FUNCTION
J1 (+IN)	Differential input connected to input balun for single-ended operation. Drive from a 50 Ohm signal source. No external termination needed.
J2 (+OUT)	Differential output connected to output balun for single-ended operation. Impedance matched to 50 Ohms for direct connection to a 50 Ohm network/spectrum analyzer input.
J3 (-IN)	Differential input. <b>Not connected by default.</b> Resistor R9 can be removed to drive the input balun differentially.
J4 (-OUT)	Differential output. <b>Not connected by default.</b> Capacitor at C21 can be moved to C9 to drive the differential outputs.
J5 (VGAIN)	SMA terminal. <b>Default connected in parallel with -VG turret to the -VG pin of LTC6412.</b> Used to apply fast control signals. Move jumper R15 to location R14 and jumper R19 to location R18 to configure for +VG control.
J6 (TEST IN) J7 (TEST OUT)	Cascaded 1:1 balun thru connection. Used to estimate the loss of the input balun at the frequency of interest.

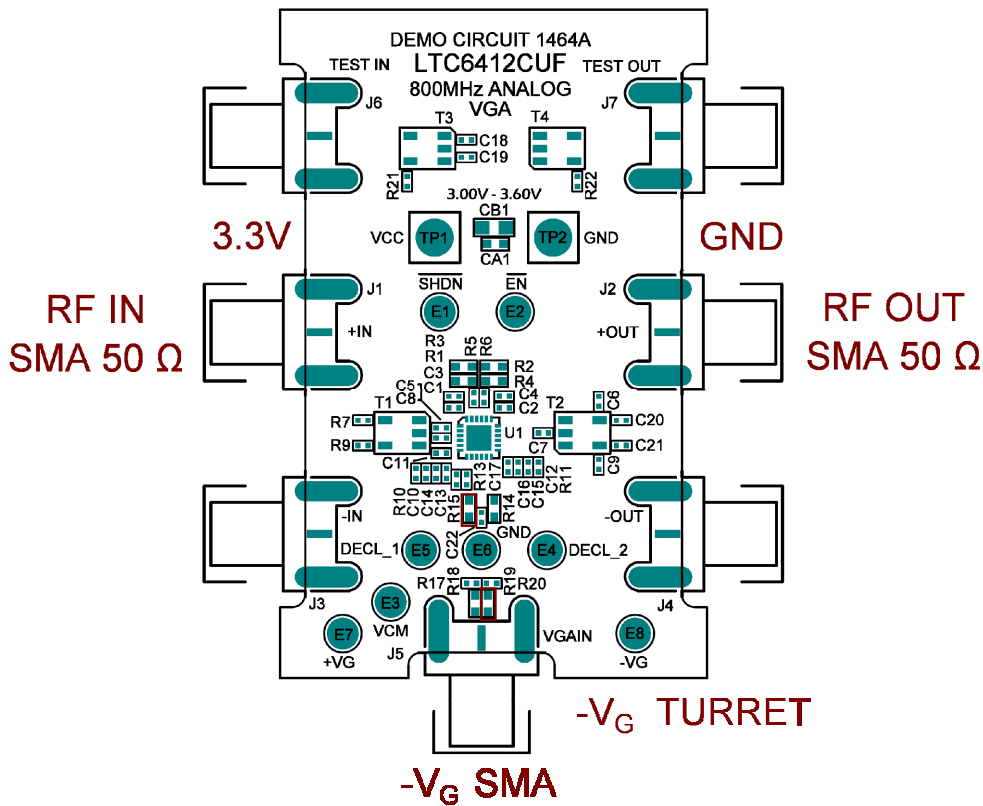

Figure 1. Picture of DC1464 Top Silkscreen with recommended default measurement setup connections shown in maroon.

## ADDITIONAL INFORMATION

### SHUTDOWN AND ENABLE

The factory default configuration is set for the power-on and amplifier-enabled state ( $\overline{\text{SHDN}}=1$ ,  $\overline{\text{EN}}=0$ ). The  $\overline{\text{SHDN}}$  pin is pulled high with a  $1\text{k}\Omega$  resistor to  $V_{\text{CC}}$ , and the  $\overline{\text{EN}}$  pin is pulled low with a  $1\text{k}\Omega$  resistor to ground. One can override these board-level defaults by applying voltages directly to the  $\overline{\text{SHDN}}$  and  $\overline{\text{EN}}$  turrets as needed.

### $-V_{\text{G}}$ AND $+V_{\text{G}}$ CONTROL

The factory default configuration is set for  $-V_{\text{G}}$  control with the  $V_{\text{GAIN}}$  SMA connector hooked in parallel with the  $-V_{\text{G}}$  turret. These control inputs can be reconfigured for  $+V_{\text{G}}$  operation by moving jumper R15 to location R14 and moving jumper R19 to location R18. Clip leads to the  $\pm V_{\text{G}}$  turrets are susceptible to noise pickup and should be lowpass filtered to avoid AM up-conversion artifacts. While using the  $\pm V_{\text{G}}$  turrets, a  $4.7\mu\text{F}$  capacitor from the  $V_{\text{GAIN}}$  SMA terminal to ground provides an effective lowpass filter with a cutoff frequency of 340 Hz.

### DIFFERENTIAL INPUTS

The inputs connectors can be configured for differential drive. Remove the jumper in location R9 to enable differential input drive (50 Ohm).

Alternatively, the input balun T1 can be removed completely and the  $\pm\text{IN}$  signals routed directly to C5 and C8 using 0603  $0\Omega$  jumpers across the input balun pads.

### DIFFERENTIAL OUTPUTS

The output connectors can be configured for differential drive. Move capacitor C21 to location C9 to enable differential output drive (50 Ohm).

Alternatively, the output balun can be removed completely with the  $\pm\text{OUT}$  signals routed to LTC6412 output pins using  $0\Omega$  0603 jumpers across the output balun pads as shown below. This transformerless configuration requires two additional inductors from the balun center tap pad to conduct supply current to the LTC6412 output pins. The inductors should choke the RF signal sufficiently at the frequency of interest while passing DC current with minimal supply drop,  $<100\text{mV}$  is recommended. A surface mount 0603 inductor is a good size choice to bridge the PCB pad gap. Keep the DC blocking capacitors at C6 and C9 to avoid a DC path to the output SMA connectors.

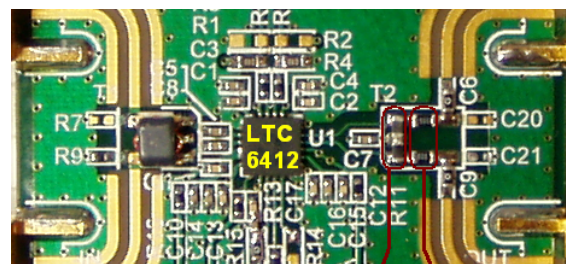

# DEMO CIRCUIT DC1464 QUICK START GUIDE FOR LTC6412

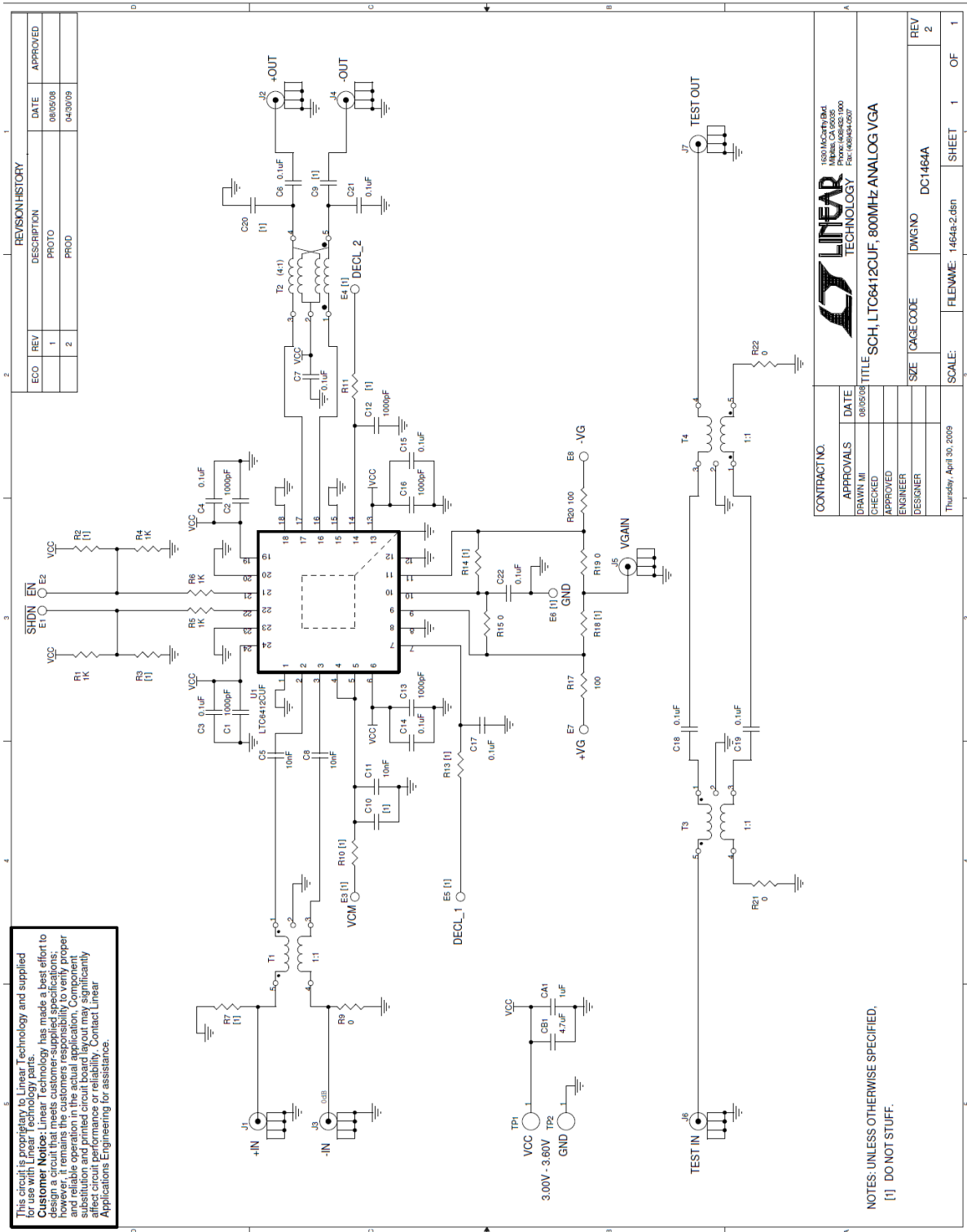

Figure 2. DC1464A Schematic

# DEMO CIRCUIT DC1464 QUICK START GUIDE FOR LTC6412

DC1464A Rev 2

4/30/2009  
MCP

Item	Qty	Ref - Des	Desc	Manufacturer's Part Number
1	1	CA1	CAP, 0603 1uF 10% 10V X5R	AVX 0603ZD105KAT2A
2	1	CB1	CAP, 0805 4.7uF 20% 6.3V X5R	TDK C2012X5R0J475M
3	5	C1,C2,C12,C13,C16	CAP, 0402 1000pF 10% 50V X7R	AVX 04025C102KAT2A
4	11	C3,C4,C6,C7,C14,C15,C17, C18,C19,C21,C22	CAP, 0402 0.1uF 10% 10V X5R	AVX 0402ZD104KAT2A
5	3	C5,C8,C11	CAP, 0402 10nF 10% 16V X7R	AVX 0402YC103KAT2A
6	0	C9,C10,C20	CAP, 0402 0.1uF 10% 10V X5R OPTION	AVX 0402ZD104KAT2A OPTION
7	4	E1,E2,E7,E8	TURRET	MILL-MAX 2308-2-00-80-00-00-07-0
8	0	E3,E4,E5,E6	TURRET OPTION	MILL-MAX 2308-2-00-80-00-00-07-0
9	7	J1,J2,J3,J4,J5,J6,J7	CONN, SMA 50-OHM EDGE-LANCH	E.F. JOHNSON, 142-0701-851
10	2	R4,R1	RES, 0603 1K OHMS 1% 1/16W	VISHAY CRCW06031K00FKED
11	0	R3,R2	DO NOT STUFF	NONE
12	2	R6,R5	RES, 0402 1K OHMS 1% 1/16W	VISHAY CRCW04021K00FKED
13	0	R7	RES, 0402 OPTION	OPTION
14	3	R9,R21,R22	RES, 0402 0 OHM JUMPER	VISHAY CRCW04020000Z0ED
15	0	R10	RES, 0402 100 OHMS 1% 1/16W OPTION	VISHAY CRCW0402100RFKED OPTION
16	0	R13,R11	RES, 0402 1K OHMS 1% 1/16W OPTION	VISHAY CRCW04021K00FKED OPTION
17	0	R14,R18	RES, 0603 0 OHM JUMPER OPTION	VISHAY CRCW06030000Z0ED OPTION
18	2	R15,R19	RES, 0603 0 OHM JUMPER	VISHAY CRCW06030000Z0ED
19	2	R20,R17	RES, 0402 100 OHMS 1% 1/16W	VISHAY CRCW0402100RFKED
20	2	TP1,TP2	TURRET	MILL MAX 2501-2-00-80-00-00-07-0
21	1	T1,T3,T4	XFMR, 1:1	TYCO MABA-007159-000000 (1:1)
22	0	T1,T3,T4-ALTERNATE		MINI-CIRCUITS TCM4-19+ (4:1)
23	1	T2	XFMR, 4:1	MINI-CIRCUITS TCM4-19+ (4:1)
24	0	T2-ALTERNATE	XFMR, 4:1	MINI-CIRCUITS TCM4-6+ (4:1)
24	1	U1	IC, LTC6412CUF	LINEAR TECH LTC6412CUF

Table 2. DC1464A Parts List

## Данный компонент на территории Российской Федерации

### Вы можете приобрести в компании MosChip.

Для оперативного оформления запроса Вам необходимо перейти по данной ссылке:

<http://moschip.ru/get-element>

Вы можете разместить у нас заказ для любого Вашего проекта, будь то серийное производство или разработка единичного прибора.

В нашем ассортименте представлены ведущие мировые производители активных и пассивных электронных компонентов.

Нашей специализацией является поставка электронной компонентной базы двойного назначения, продукции таких производителей как XILINX, Intel (ex.ALTERA), Vicor, Microchip, Texas Instruments, Analog Devices, Mini-Circuits, Amphenol, Glenair.

Сотрудничество с глобальными дистрибьюторами электронных компонентов, предоставляет возможность заказывать и получать с международных складов практически любой перечень компонентов в оптимальные для Вас сроки.

На всех этапах разработки и производства наши партнеры могут получить квалифицированную поддержку опытных инженеров.

Система менеджмента качества компании отвечает требованиям в соответствии с ГОСТ Р ИСО 9001, ГОСТ РВ 0015-002 и ЭС РД 009

### Офис по работе с юридическими лицами:

105318, г.Москва, ул.Щербаковская д.3, офис 1107, 1118, ДЦ «Щербаковский»

Телефон: +7 495 668-12-70 (многоканальный)

Факс: +7 495 668-12-70 (доб.304)

E-mail: [info@moschip.ru](mailto:info@moschip.ru)

Skype отдела продаж:

moschip.ru

moschip.ru\_4

moschip.ru\_6

moschip.ru\_9