

Applications

- 802.11b WLAN
- 802.11g WLAN
- 802.11a WLAN
- TX-RX Switching
- Antenna Diversity Switching
- Test and Measurement
- General Purpose Broadband Wireless

Product Features

- Integrated TX-RX and Diversity Switch for Dual-band 802.11a/b/g WLAN Systems
- 0.1 to 6.0 GHz Frequency Coverage
- Low Insertion Loss
- High Isolation
- Positive Control Voltage
- No Supply Voltage Necessary
- GaAs pHEMT Technology
- Leadless 3.0 x 3.0 x 0.85 mm Pb-Free SMT Package

General Description

The TQS5202 is a dual-band, double-pole double-throw switch configured for TX-RX and antenna diversity switching applications for the WLAN market and other general purpose transfer switch applications.

The TQS5202 exhibits industry-leading insertion loss, isolation and power handling. It requires no fixed supply voltage and operates with a positive control voltage.

The TQS5202 is manufactured using TriQuint's GaAs pHEMT process and is packaged in an industry standard 3.0 x 3.0 x 0.85 mm VQFN-12 Pb-Free package.

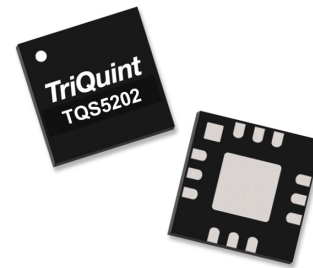

12-pin 3x3 mm QFN Package

Functional Block Diagram

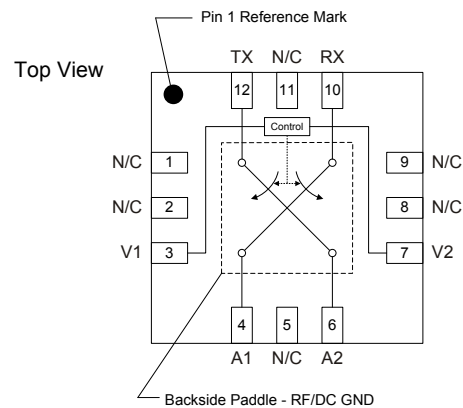

Pin Configuration

Pin No.	Symbol
1, 2, 5, 8, 9, 11	N/C
3	V1
4	A1
6	A2
7	V2
10	RX
12	TX
Backside Paddle	RF/DC GND

Ordering Information

Part No.	Description
TQS5202	SP3T Reflective Switch
TQS5202-PCB	0.1 - 6.0 GHz Evaluation Board

Standard T/R size = 2500 pieces on a 7" reel

Absolute Maximum Ratings

Parameter	Rating
Storage Temperature	-40 to 150°C
RF Input Power, CW, 50Ω, T = 25°C	+35 dBm
Control Voltage Range	-5.0 to +5.0 V

Operation of this device outside the parameter ranges given above may cause permanent damage.

Recommended Operating Conditions

Parameter	Min	Typ	Max	Units
V _{CTRL} High State	2.5		5.0	V
Operating Temp. Range	-40		+85	°C

Electrical specifications are measured at specified test conditions. Specifications are not guaranteed over all recommended operating conditions.

Electrical Specifications

Test conditions unless otherwise noted: Temp.=+25°C, 50 Ω system

Parameter	Conditions	Min	Typ	Max	Units
Operational Frequency Range		100		6000	MHz
Control Voltage	Low	0		0.2	V
	High	2.5	3.0	5.0	V
Insertion Loss	0.1 – 6 GHz			1.5	dB
	2.3 – 2.5 GHz		0.8	1.1	
	4.9 – 6.0 GHz ⁽⁵⁾		0.95	1.35	
Isolation	0.1 – 6 GHz	20	25		dB
	2.3 – 2.5 GHz	25	33		
	4.9 – 6.0 GHz ⁽⁵⁾	20	28		
Return Loss	0.1 – 6 GHz		12		dB
	2.3 – 2.5 GHz		15		
	4.9 – 6.0 GHz ⁽⁵⁾		15		
Input P1dB ⁽¹⁾	2.3 – 2.5 GHz		+33		dBm
	4.9 – 6.0 GHz		+29		
Input P1dB ⁽²⁾	2.3 – 2.5 GHz		+31		dBm
	4.9 – 6.0 GHz		+27		
Input IP3 ⁽¹⁾⁽³⁾	2.3 – 2.5 GHz		+50		dBm
	4.9 – 6.0 GHz		+50		
Harmonics (2f0) ⁽⁴⁾	2.3 – 2.5 GHz		80		dBc
	4.9 – 6.0 GHz		75		
Harmonics (3f0) ⁽⁴⁾	2.3 – 2.5 GHz		85		dBc
	4.9 – 6.0 GHz		85		
Control Voltage Bias Current	V1 or V2 or V3=5 V			50	uA

Notes:

- V_{CTRL}=3.0 V / 0 V
- V_{CTRL}=2.6 V / 0 V
- P_{IN}=+20 dBm/tone, Δf=1 MHz
- P_{IN}=+20 dBm
- Using 3pF blocking caps

Digital Control Voltages

State	Bias Condition
Low	≤ 0.2V
High	≥ 2.5 V

Switch Control Truth Table

Control Voltages		Signal Path State			
V1	V2	A1-TX	A2-TX	A1-RX	A2-RX
Low	High	ON	OFF	OFF	ON
High	Low	OFF	ON	ON	OFF
All Other States		N/A	N/A	N/A	N/A

TQS5202-PCB Evaluation Board

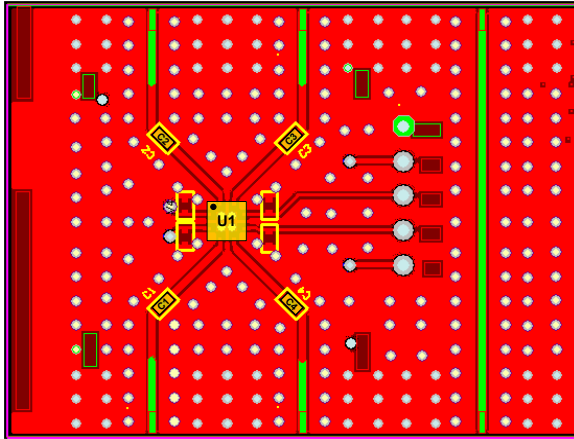

Notes:

1. See Evaluation Board PCB Specifications section for material and stack-up.
2. C1,C2,C3 and C4 = 100pF.

Performance Plots - (TQS5202-PCB)

Test conditions unless otherwise noted: $V_{CTRL}=3.0\text{ V} / 0.0\text{ V}$, Temp= $+25^{\circ}\text{C}$, 50 Ω system

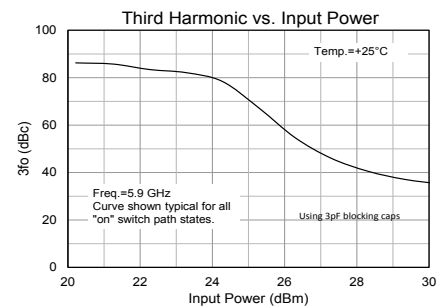
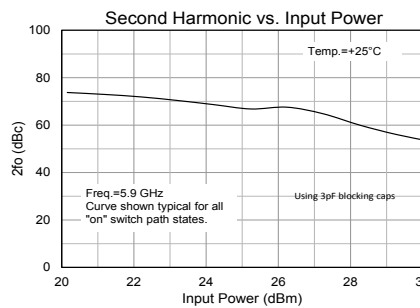
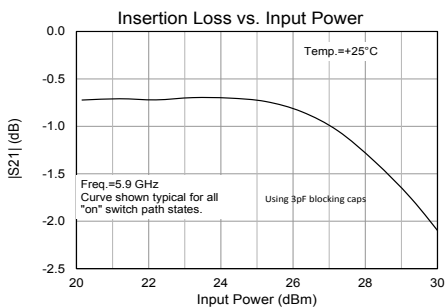
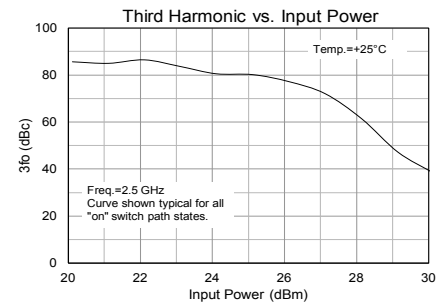
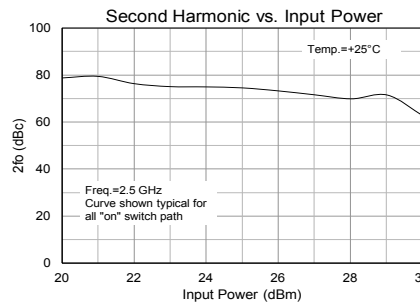
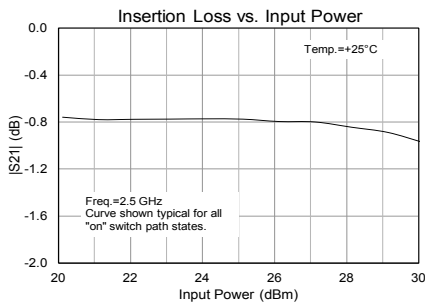
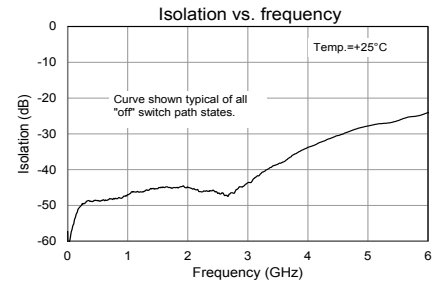
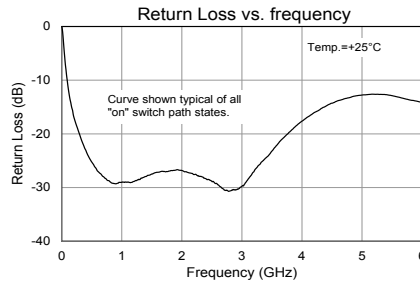
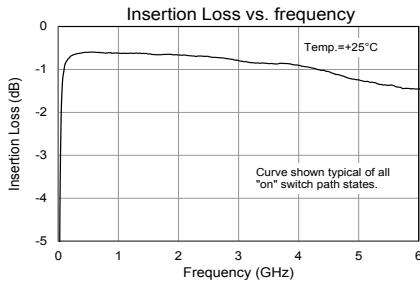

Pin Configuration and Description

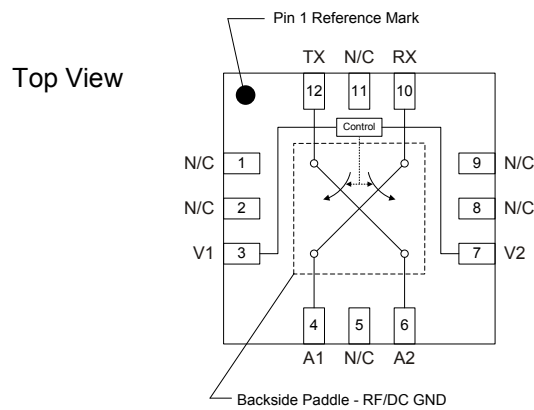

Pin No.	Symbol	Description
1, 2, 5, 8, 9, 11	N/C	No internal electrical connection. Provide grounded land pads for PCB mounting integrity.
3	V1	Switch state control voltage 1
4	A1	Antenna Port 1
6	A2	Antenna Port 2
7	V2	Switch state control voltage 2
10	RX	Receive Port
12	TX	Transmit Port
Backside Paddle	RF/DC GND	RF/DC Ground. Use recommended via pattern and ensure good solder attach for best thermal and electrical performance.

Evaluation Board PCB Specifications

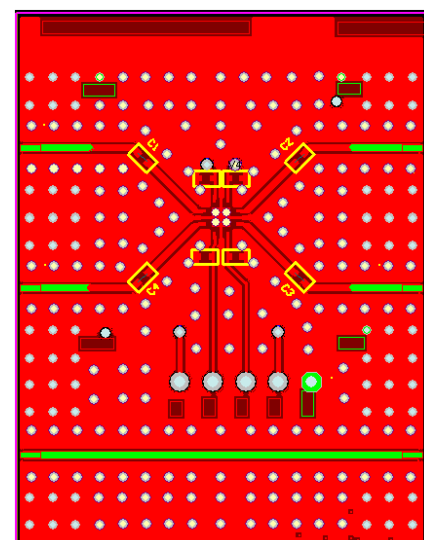
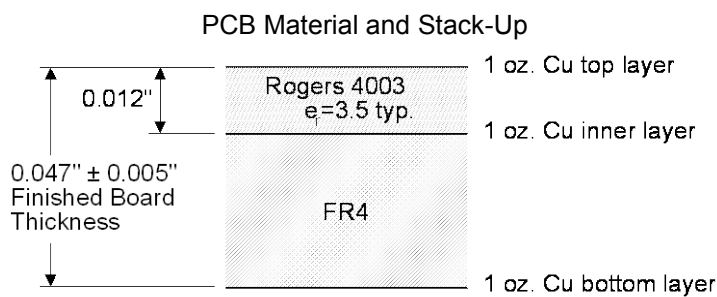

Mechanical Information

Package Marking and Dimensions

Marking: Product Code – 5202
 Assembly Code - XXXX
 Year/Week - YYWW

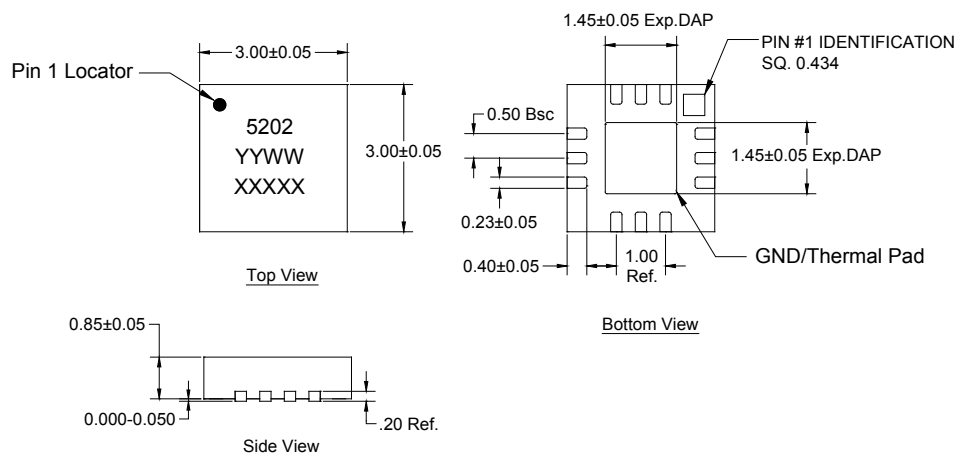

Notes:

1. All dimensions are in millimeters . Angles are in degrees.
2. Dimension and tolerance formats conform to ASME Y14.4M-1994.
3. The terminal #1 identifier and terminal numbering conform to JESD 95-1 SPP-012.

PCB Mounting Pattern

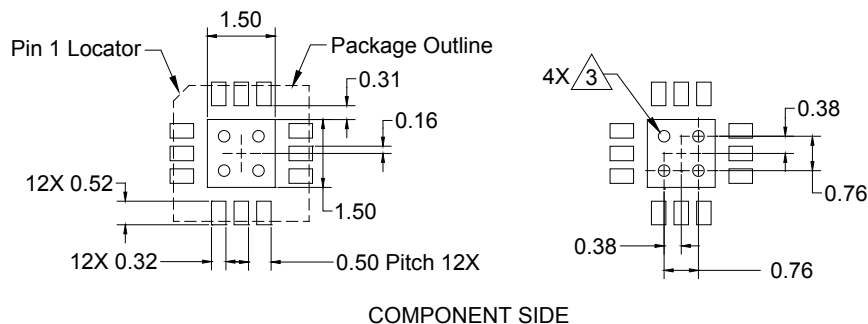

Notes:

1. All dimensions are in millimeters. Angles are in degrees.
2. Use 1 oz. copper minimum for top and bottom layer metal.
3. We recommend a 0.35mm (#80/.0135") diameter bit for drilling via holes and a final plated thru diameter of 0.25 mm (0.10").
4. Ensure good package backside paddle solder attach for reliable operation and best electrical performance.

Important Notice

For the latest specifications, additional product information, worldwide sales and distribution locations, and information about TriQuint:

Web: www.triquint.com **Tel:** +1.503.615.9000
Email: info-sales@triquint.com **Fax:** +1.503.615.8902

For technical questions and application information:

Email: sjcapplications.engineering@triquint.com

Contact Information

The information contained herein is believed to be reliable. TriQuint makes no warranties regarding the information contained herein. TriQuint assumes no responsibility or liability whatsoever for any of the information contained herein. TriQuint assumes no responsibility or liability whatsoever for the use of the information contained herein. The information contained herein is provided "AS IS, WHERE IS" and with all faults, and the entire risk associated with such information is entirely with the user. All information contained herein is subject to change without notice. Customers should obtain and verify the latest relevant information before placing orders for TriQuint products. The information contained herein or any use of such information does not grant, explicitly or implicitly, to any party any patent rights, licenses, or any other intellectual property rights, whether with regard to such information itself or anything described by such information.

TriQuint products are not warranted or authorized for use as critical components in medical, life-saving, or life-sustaining applications, or other applications where a failure would reasonably be expected to cause severe personal injury or death.

Данный компонент на территории Российской Федерации

Вы можете приобрести в компании MosChip.

Для оперативного оформления запроса Вам необходимо перейти по данной ссылке:

<http://moschip.ru/get-element>

Вы можете разместить у нас заказ для любого Вашего проекта, будь то серийное производство или разработка единичного прибора.

В нашем ассортименте представлены ведущие мировые производители активных и пассивных электронных компонентов.

Нашей специализацией является поставка электронной компонентной базы двойного назначения, продукции таких производителей как XILINX, Intel (ex.ALTERA), Vicor, Microchip, Texas Instruments, Analog Devices, Mini-Circuits, Amphenol, Glenair.

Сотрудничество с глобальными дистрибьюторами электронных компонентов, предоставляет возможность заказывать и получать с международных складов практически любой перечень компонентов в оптимальные для Вас сроки.

На всех этапах разработки и производства наши партнеры могут получить квалифицированную поддержку опытных инженеров.

Система менеджмента качества компании отвечает требованиям в соответствии с ГОСТ Р ИСО 9001, ГОСТ РВ 0015-002 и ЭС РД 009

Офис по работе с юридическими лицами:

105318, г.Москва, ул.Щербаковская д.3, офис 1107, 1118, ДЦ «Щербаковский»

Телефон: +7 495 668-12-70 (многоканальный)

Факс: +7 495 668-12-70 (доб.304)

E-mail: info@moschip.ru

Skype отдела продаж:

moschip.ru

moschip.ru_4

moschip.ru_6

moschip.ru_9