

WPMDB1600362Q / 171060302**MagI³C** Power Module
VDRM – Variable Step Down Regulator Module**2.95 – 6V / 6A / 0.8 – 3.6V Output****DESCRIPTION**

The VDRM 1710x0302 series of the MagI³C Power Module family provide a fully integrated DC-DC power supply including the switching regulator with integrated MOSFETs, compensation and shielded inductor in one package. These modules require as few as 4 external components.

The 171060302 offers high efficiency and delivers up to 6A of output current. It operates with an input voltage from 2.95 to 6V and is designed for fast transient response.

It is available in a standard industrial high power density QFN package (11mm x 9mm x 2.8mm) with very good thermal performance.

This module has an on-board protection circuitry to guard against thermal overstress and electrical damage featuring thermal shutdown, over-current, short-circuit, overvoltage and undervoltage protections.

TYPICAL APPLICATIONS

- Point-of-load DC-DC applications from 5V and 3.3V rails
- Industrial, test & measurement, medical applications
- Communication infrastructure
- System power supplies
- DSPs, FPGAs, MCUs and MPU supply
- I/O interface power supply
- High density distributed power systems

FEATURES

- Peak efficiency up to 96%
- Current capability up to 6A
- Input voltage range: 2.95 to 6V
- Output voltage range: 0.8 to 3.6V
- Continuous output power: 21.6W
- Integrated shielded inductor
- Low output voltage ripple: 4mV typ.
- Reference accuracy over temperature: 1% max.
- Adjustable switching frequency: 0.5 to 2 MHz
- Current Mode control
- Synchronous operation
- Forced continuous mode under light load
- Undervoltage lockout protection (UVLO)
- Adjustable soft-start and voltage tracking
- Frequency synchronization with external clock
- Sequencing
- Thermal shutdown
- Short circuit protection
- Cycle-by-cycle current limit
- Output overvoltage protection
- Output undervoltage and overvoltage Power Good
- Pin compatible with 171020302 & 171040302
- Operating ambient temperature up to 85°C
- No derating within the operating temperature range
- Operating junction temp. range: -40 to 125°C
- UL94V-0 package material
- Complies with EN55022 class B radiated emissions standard

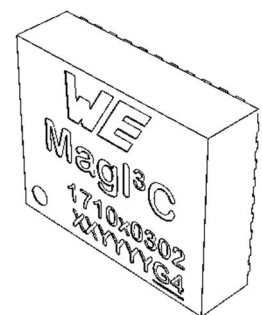
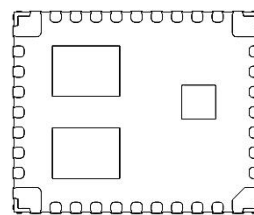
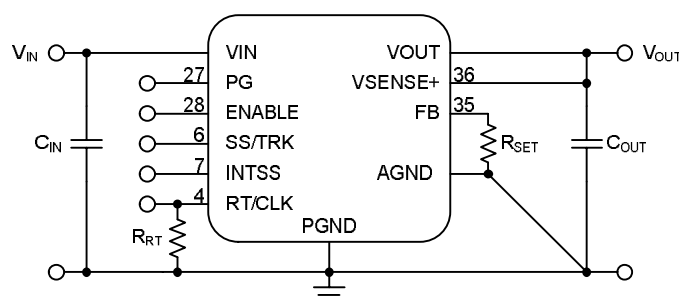
**TYPICAL CIRCUIT DIAGRAM**

WPMDB1600362Q / 171060302

MagI³C Power Module
VDRM – Variable Step Down Regulator Module



PACKAGE

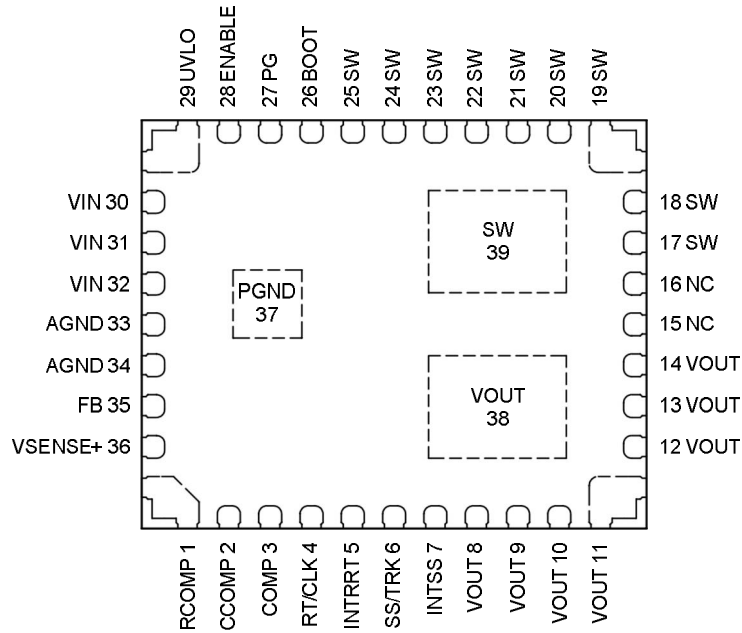

Top View

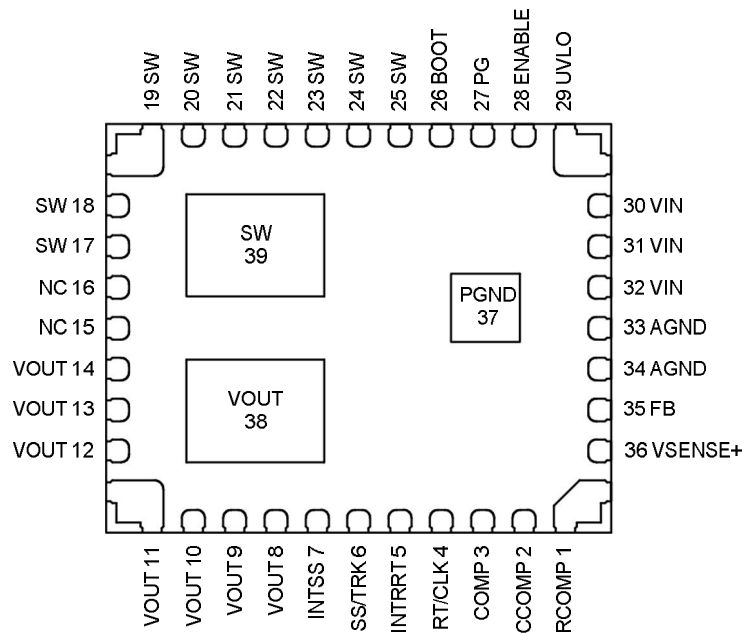

Bottom View

WPMDB1600362Q / 171060302

MagI³C Power Module
 VDRM – Variable Step Down Regulator Module

PIN DESCRIPTION

SYMBOL	NUMBER	TYPE	DESCRIPTION
VIN	30,31,32	Power	Input Voltage. Place input capacitors as close as possible
VOUT	8,9,10,11, 12,13,14, 38	Power	Output voltage. Place output capacitors as close as possible. For thermal performance use copper plane(s) at these pins.
AGND	33,34	Supply	Analog ground for internal circuitry. Connect to power ground
PGND	37	Power	Power ground for the internal switching circuitry. Connect to copper plane(s) with thermal vias for thermal performance.
VSENSE+	36	Input	Connect to positive terminal of the output capacitor. An internal resistor of 1430 Ω is connected internally between V _{SENSE+} and FB. This is the upper resistor of the feedback voltage divider.
FB	35	Input	A resistor (R _{SET}) from FB to AGND is needed to select the output voltage. This is the lower resistor of the feedback voltage divider.
RT/CLK	4	Input	An external resistor from RT/CLK to AGND adjusts the switching frequency of the device. This pin can also be used to synchronize with an external clock.
INTRRT	5	Analog	Internal resistor which defines the default switching frequency.
RCOMP	1	Analog	Internal resistor of the compensation network. Must be connected to AGND.

OPTIONAL

SYMBOL	NUMBER	TYPE	DESCRIPTION
UVLO	29	Input	An internal undervoltage lock out resistor of 34k Ω is connected to the enable pin. If connected to analog ground, the internal UVLO resistor divider will be activated. For input voltages below 3.3V this pin should be left open and an optional resistor from enable to analog ground sets the UVLO to values between 2.95 and 3.3 V.
ENABLE	28	Input	Enable pin. Internally pull-up source. Pull to analog ground to disable. Float to Enable.
PG	27	Output	Open drain output. The PG pin pulls low during thermal shutdown, over-current, output overvoltage or undervoltage or disabled device. A pull-up resistor is required.
SS/TRK	6	Input	Internal current source. Connect an external capacitor to optionally increase the soft-start time. A voltage applied to this pin allows tracking and sequencing.
INTSS	7	Analog	An internal 3.3nF capacitor is connected to this pin. If pin 7 is connected to analog ground, a 1.1ms soft-start time is selected.

AUXILIARY

SYMBOL	NUMBER	TYPE	DESCRIPTION
COMP	3	Output	Output of the error amplifier. If an external compensation is used, pin 1 must be left open.
CCOMP	2	Analog	Internal capacitor of the compensation network. Do not connect.
BOOT	26	Supply	Internal bootstrap pin for the high side MOSFET.
SWITCH	17,18,19, 20,21,22, 23,24,25, 39	Power	Internal switch node. Do not connect these pins.
NC	15,16		Not connected to internal circuitry.

WPMDB1600362Q / 171060302

MagI³C Power Module
VDRM – Variable Step Down Regulator Module

**ORDERING INFORMATION**

ORDER CODE	PART DESCRIPTION	SPECIFICATIONS	PACKAGE	PACKAGING UNIT
171060302	WPMDB1600362Q	6A / 21.6W version	BQFN-39	Tape and Reel, 250 pieces
178060302	Evaluation Board	6A / 21.6W version		1

PIN COMPATIBLE FAMILY MEMBERS

ORDER CODE	PART DESCRIPTION	SPECIFICATIONS	PACKAGE	PACKAGING UNIT
171020302	WPMDB1200362Q	2A / 7.2W version	BQFN-39	Tape and Reel, 250 pieces
178020302	Evaluation Board	2A / 7.2W version		1
171040302	WPMDB1400362Q	4A / 14.4W version	BQFN-39	Tape and Reel, 250 pieces
178040302	Evaluation Board	4A / 14.W version		1

PACKAGE SPECIFICATIONS

Weight	Molding compound	UL class	Certificate number
0.54g	EME-G770H	UL94 V-0	E41429

SALES INFORMATION

SALES CONTACTS
<p>Würth Elektronik eiSos GmbH & Co. KG EMC & Inductive Solutions Max-Eyth-Str. 1 74638 Waldenburg Germany Tel. +49 (0) 7942 945 0 www.we-online.com powermodules@we-online.com</p>

WPMDB1600362Q / 171060302

MagI³C Power Module
VDRM – Variable Step Down Regulator Module

ABSOLUTE MAXIMUM RATINGS

Caution:

Exceeding the listed absolute maximum ratings may affect the device negatively and may cause permanent damage.

SYMBOL	PARAMETER	LIMITS		UNIT
		MIN ⁽¹⁾	MAX ⁽¹⁾	
VIN	Input voltage	-0.3	7	V
VOUT	Output voltage	-0.6	V _{IN}	V
FB	Feedback voltage	-0.3	3	V
UVLO	Undervoltage lockout pin voltage	-0.3	3.3	V
EN	Enable pin Voltage	-0.3	7	V
	Enable source current	-	100	μA
RT/CLK	RT/CLK pin voltage	-0.3	6	V
	RT/CLK source current	-	±100	μA
SS/TRK	SS/TRK pin voltage	-0.3	3	V
	SS/TRK pin sink current	-	±100	μA
PG	Power Good pin voltage	-0.3	7	V
	Power Good sink current	-	10	mA
COMP	Output of the error amplifier pin voltage	-0.3	3	V
	COMP sink current	-	100	μA
INTSS	Internal soft-start capacitor pin voltage	-0.3	3	V
INTRRT	Internal resistor for the initial switching frequency pin voltage	-0.3	6	V
RCOMP	Resistor of the compensation network pin voltage	-0.3	3	V
CCOMP	Capacitor of the compensation network pin voltage	-0.3	3	V
VSENSE+	V _{OUT} sense pin voltage	-0.3	V _{out}	V
SW	Switch node pin voltage	-0.6	7	V
	10ns transient	-2	7	V
BOOT	Internal supply for the high MOSFET driver pin voltage	-	V _{SW} +8V	V
T _{storage}	Assembled, non operating storage temperature	-65	150	°C
T _{SOLR}	Peak case/leads temperature during reflow soldering, max. 30sec. (JEDEC J-STD020) Maximum three cycles!	-	245±5	°C
Mechanical shock: Mil-STD-883D, Method 2002.2, 1ms, ½ sine, mounted		-	1500	G
Mechanical vibration: Mil-STD-883D, Method 2007.2, 20-2000Hz		-	20	G

WPMDB1600362Q / 171060302**MagI³C** Power Module
VDRM – Variable Step Down Regulator Module**OPERATING CONDITIONS**

Operating conditions are conditions under which operation of the device is intended to be functional. All values are referenced to GND.

MIN and MAX limits are valid for the recommended ambient temperature range of **-40°C to 85°C**. Typical values represents statistically the utmost probability at following conditions: $V_{IN} = 3.3V$, $V_{OUT} = 1.8V$, $I_{OUT} = 6A$, $C_{IN1} = 47\mu F$ ceramic, $C_{IN2} = 220\mu F$ polymer electrolytic, $C_{OUT1} = 47\mu F$ ceramic, $C_{OUT2} = 100\mu F$ poly-tantalum unless otherwise noted.

SYMBOL	PARAMETER	MIN ⁽¹⁾	TYP ⁽²⁾	MAX ⁽¹⁾	UNIT
V_{IN}	Input voltage	2.95	-	6	V
V_{OUT}	Output voltage (depending on input voltage and switching frequency)	0.8	-	3.6	V
T_A	Ambient temperature range	-40	-	85 ⁽³⁾	°C
T_{JOP}	Junction temperature range	-40	-	125	°C
I_{OUT}	Nominal output current			6	A

THERMAL SPECIFICATIONS

SYMBOL	PARAMETER	TYP ⁽²⁾	UNIT
Θ_{JA}	Junction-to-ambient thermal resistance ⁽⁴⁾	12	°C/W
Ψ_{JT}	Junction-to-top ⁽⁵⁾	2.2	°C/W
Ψ_{JB}	Junction-to-board ⁽⁶⁾	9.7	°C/W
T_{SD}	Thermal shutdown, rising	175	°C
	Thermal shutdown hysteresis, falling	15	°C

WPMDB1600362Q / 171060302

MagI³C Power Module
VDRM – Variable Step Down Regulator Module

ELECTRICAL SPECIFICATIONS

MIN and MAX limits are valid for the recommended ambient temperature range of **-40°C to 85°C**. Typical values represents statistically the utmost probability at following conditions: $V_{IN} = 3.3V$, $V_{OUT} = 1.8V$, $I_{OUT} = 6A$, $C_{IN1} = 47\mu F$ ceramic, $C_{IN2} = 220\mu F$ polymer electrolytic, $C_{OUT1} = 47\mu F$ ceramic, $C_{OUT2} = 100\mu F$ poly-tantalum unless otherwise noted.

SYMBOL	PARAMETER	TEST CONDITIONS	MIN ⁽¹⁾	TYP ⁽²⁾	MAX ⁽¹⁾	UNIT
Output current						
I_{OCP}	Over current protection		-	9	-	A
Accuracy						
V_{FB}	Reference accuracy	$T_A = 25^\circ C$, $I_{OUT} = 0A$ with internal feedback resistor	-	-	$\pm 1^{(7)}$	%
	Temperature variation	$-40^\circ C \leq T_A \leq 85^\circ C$, $I_{OUT} = 0A$	-	± 0.3	-	%
V_{OUT}	Line regulation	Over V_{IN} range, $T_A = 25^\circ C$, $I_{OUT} = 0A$	-	± 0.1	-	%
	Load regulation	Over I_{OUT} range, $T_A = 25^\circ C$	-	± 0.1	-	%
	Total output voltage variation		-	-	± 1.5	%
	Output voltage ripple	10 μF ceramic, 20MHz BW ⁽⁸⁾	-	4	-	mV _{pp}
Switching frequency						
f_{SW}	Switching frequency	Using RT mode	500	-	2000	kHz
		RT/CLK pin open	400	500	600	kHz
f_{CLK}	Synchronization clock frequency range	Using CLK mode	500	-	2000	kHz
	Minimum CLK pulse width		75	-	-	ns
V_{CLK-H}	RT/CLK high threshold	Relative to AGND	2.2	-	3.3	V
V_{CLK-L}	RT/CLK low threshold		-0.3	-	0.4	V
f_{CLK}	RT/CLK to switch node delay		-	90	-	ns
	PLL lock-in-time		-	14	-	μs
Enable and undervoltage lockout						
V_{UVLO}	V_{IN} undervoltage threshold	V_{IN} increasing, UVLO pin connected to AGND	-	3.05	3.135	V
		V_{IN} decreasing, UVLO pin connected to AGND	2.5	2.75	-	V
V_{ENABLE}	Enable threshold trip point	Enable logic high voltage	-	1.25	-	V
		Enable logic low voltage	-0.3	-	1.0	V
Power Good						
PG	Power Good threshold	V_{OUT} rising, V_{OUT} GOOD	-	93	-	%
		V_{OUT} rising, V_{OUT} FAULT	-	109	-	%
		V_{OUT} falling, V_{OUT} GOOD	-	107	-	%
		V_{OUT} falling, V_{OUT} FAULT	-	91	-	%
	Power Good low voltage	$I_{PG} = 0.33mA$	-	-	0.3	V

WPMDB1600362Q / 171060302

MagI³C Power Module
VDRM – Variable Step Down Regulator Module



ELECTRICAL SPECIFICATIONS

SYMBOL	PARAMETER	TEST CONDITIONS	MIN ⁽¹⁾	TYP ⁽²⁾	MAX ⁽¹⁾	UNIT			
Efficiency									
η	Efficiency	$V_{IN} = 5V$ $I_{OUT} = 3A$	$V_{OUT} = 3.3V, f_{SW} = 1.0MHz$	-	95	-	%		
			$V_{OUT} = 2.5V, f_{SW} = 1.0MHz$	-	93	-	%		
			$V_{OUT} = 1.8V, f_{SW} = 1.0MHz$	-	92	-	%		
			$V_{OUT} = 1.5V, f_{SW} = 1.0MHz$	-	90	-	%		
			$V_{OUT} = 1.2V, f_{SW} = 750kHz$	-	89	-	%		
			$V_{OUT} = 1.0V, f_{SW} = 650kHz$	-	87	-	%		
			$V_{OUT} = 0.8V, f_{SW} = 650kHz$	-	85	-	%		
		$V_{IN} = 3.3V$ $I_{OUT} = 3A$	$V_{OUT} = 1.8V, f_{SW} = 1.0MHz$	-	91	-	%		
			$V_{OUT} = 1.5V, f_{SW} = 1.0MHz$	-	90	-	%		
			$V_{OUT} = 1.2V, f_{SW} = 750kHz$	-	88	-	%		
			$V_{OUT} = 1.0V, f_{SW} = 650kHz$	-	87	-	%		
			$V_{OUT} = 0.8V, f_{SW} = 650kHz$	-	84	-	%		
			Input and output capacitors						
			C_{IN}	External input capacitor	ceramic	47 ⁽⁹⁾	-	-	μF
Non ceramic	-	220 ⁽⁹⁾			-	μF			
C_{OUT}	External output capacitor	ceramic	47 ⁽¹⁰⁾	150	650 ⁽¹¹⁾	μF			
		Non ceramic	-	100 ⁽¹⁰⁾	1000 ⁽¹¹⁾	μF			
	Output capacitor ESR	-	-	25	$m\Omega$				
Transient Response									
T_{TR}	Transient Response	Recovery time 1A/ μs load step from 1.5A to 4.5A	-	80	-	μs			
		V_{OUT} over/undershoot 1A/ μs load step from 1.5A to 4.5A	-	120	-	mV			
Input quiescent current									
I_{SD}	Shutdown quiescent current	$V_{ENABLE} = 0V$	-	70	100	μA			

RELIABILITY

SYMBOL	PARAMETER	TEST CONDITIONS	MIN ⁽¹⁾	TYP ⁽²⁾	MAX ⁽¹⁾	UNIT
MTBF	Mean Time Between Failures	Confidence level 60%, $T_A=55^\circ C$, Activation energy 0.7eV, 1000 hrs test duration, 128756 samples, 0 fail		$1 \cdot 10^{10}$		h

WPMDB1600362Q / 171060302**MagI³C** Power Module
VDRM – Variable Step Down Regulator Module**NOTES**

- (1) Min and Max limits are 100% production tested at 25°C. Limits over the operating temperature range are guaranteed through correlation using Statistical Quality Control (SQC) methods.
- (2) Typical numbers are valid at 25°C ambient temperature and represent statistically the utmost probability assuming the Gaussian distribution.
- (3) Depending on heat sink design, number of PCB layers, copper thickness and air flow.
- (4) Measured on a 100 x 100mm two layer board, with 35µm (1 ounce) copper, no air flow
- (5) The junction-to-top characterization parameter, Ψ_{JT} , estimates the junction temperature, T_J , of a device in a real system, using a procedure described in JESD51-2A (sections 6 and 7). $T_J = \Psi_{JT} * P_{dis} + T_T$; where P_{dis} is the power dissipated in the device and T_T is the temperature of the top of the device.
- (6) The junction-to-board characterization parameter, Ψ_{JB} , estimates the junction temperature, T_J , of a device in a real system, using a procedure described in JESD51-2A (sections 6 and 7). $T_J = \Psi_{JB} * P_{dis} + T_B$; where P_{dis} is the power dissipated in the device and T_B is the temperature of the board 1mm from the device.
- (7) The stated limit of the set-point voltage tolerance includes the tolerance of both the internal voltage reference and the internal adjustment resistor. The overall output voltage tolerance is affected by the tolerance of the external R_{SET} resistor.
- (8) The industry standard for comparison of the output voltage ripple between switching regulators or modules requires a 10µF ceramic (sometimes additional 1µF ceramic in parallel) at the point of load where the voltage measurement is done using an oscilloscope with its probe and probe jack for low voltage/high frequency (low impedance) measurement. The oscilloscopes bandwidth is limited at 20MHz.
- (9) A minimum of 47µF of ceramic capacitance is required across the input for proper operation. Locate the capacitor directly at V_{IN} of the device. An additional 220µF of bulk capacitance is recommended.
- (10) The amount of required output capacitance varies depending on the output voltage. The amount of required capacitance must include at least 47µF of ceramic capacitance. Locate the capacitance close to the device. Adding additional capacitance close to the load improves the response of the regulator to load transients.
- (11) When using both ceramic and non-ceramic output capacitance, the combined maximum must not exceed 1200µF.

WPMDB1600362Q / 171060302

Mag³C Power Module
VDRM – Variable Step Down Regulator Module



TYPICAL PERFORMANCE CURVES

If not otherwise specified, the following conditions apply: $V_{IN} = 3.3V - 5V$; $C_{IN} = 2 \times 47\mu F$ X7R ceramic; $C_{OUT} = 2 \times 47\mu F$ X7R ceramic, $T_{AMB} = 25^{\circ}C$.

RADIATED EMISSIONS EN55022 (CISPR-22) CLASS B COMPLIANT

Measured on module with PCB and without external filters at 3m antenna distance

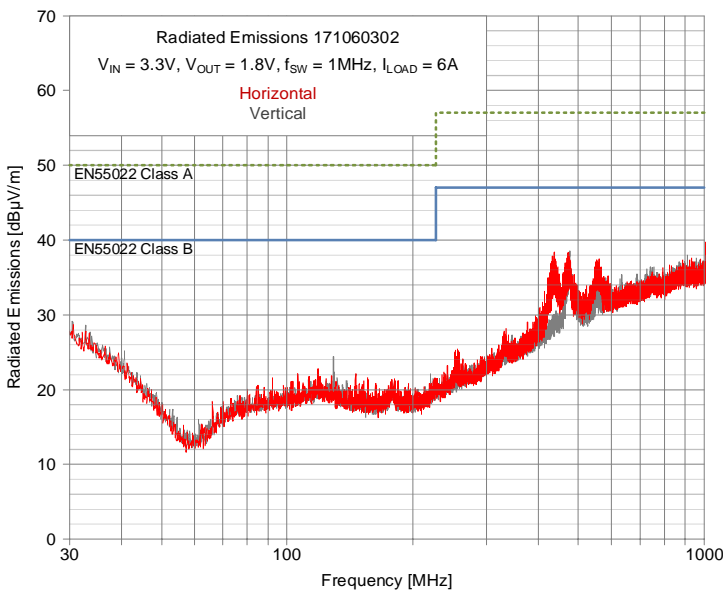
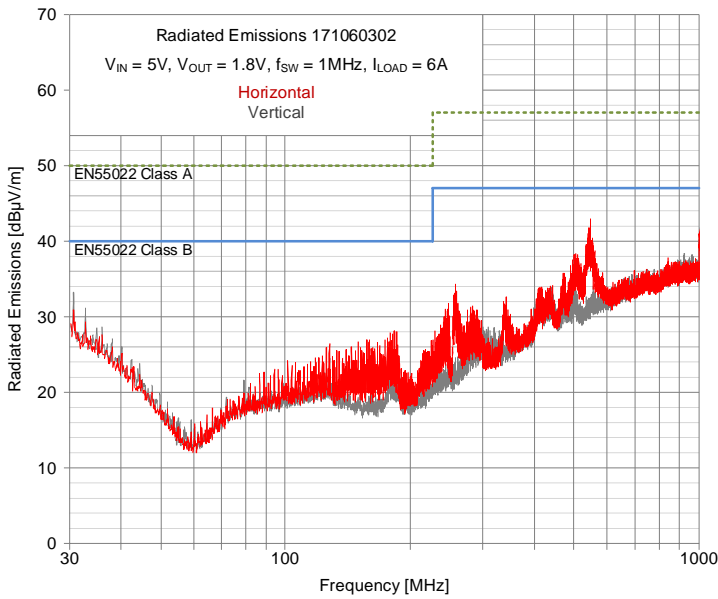

WPMDB1600362Q / 171060302

MagI³C Power Module
 VDRM – Variable Step Down Regulator Module



EFFICIENCY

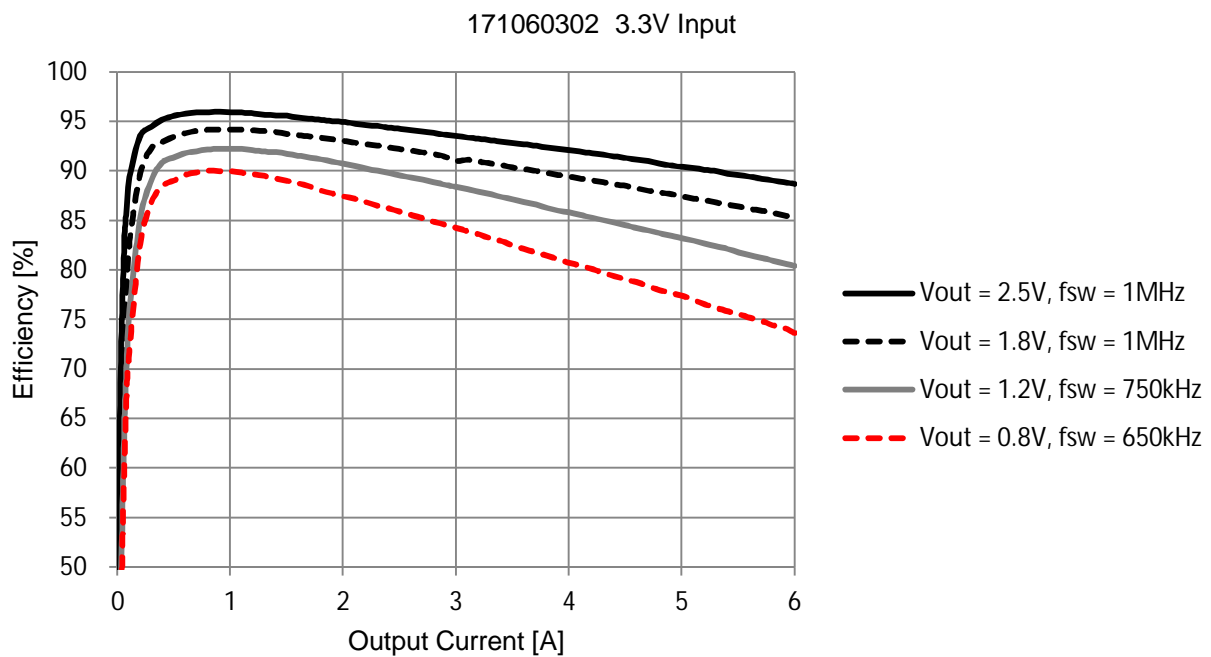
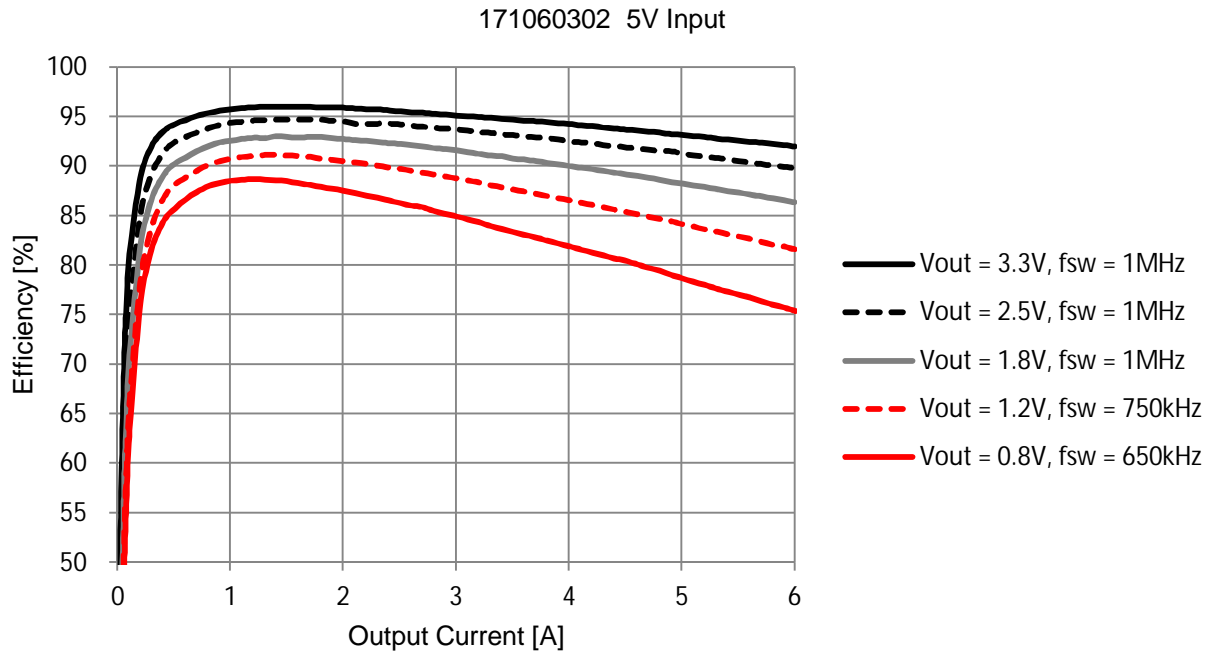

WPMDB1600362Q / 171060302

MagI³C Power Module
VDRM – Variable Step Down Regulator Module



POWER DISSIPATION

171060302 5V Input

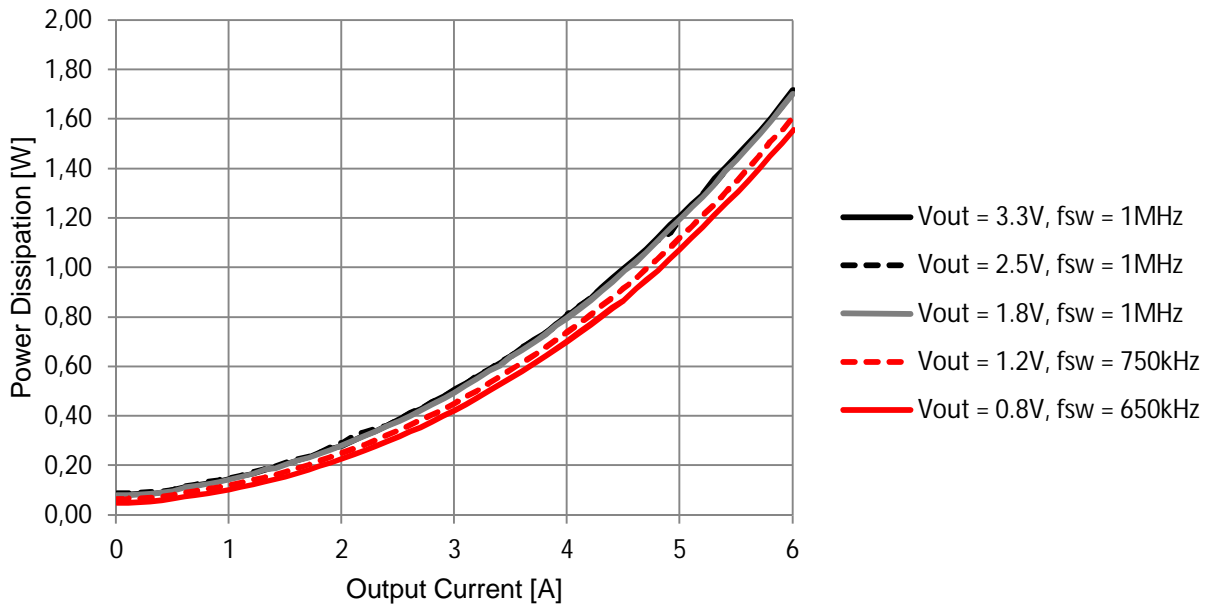

171060302 3.3V Input

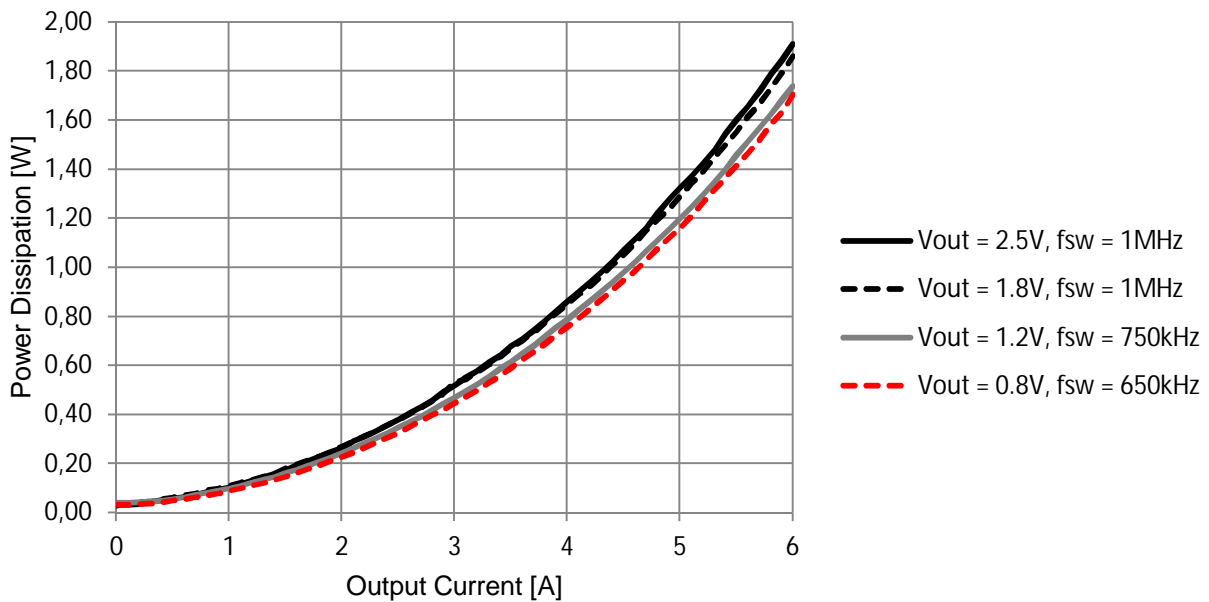

WPMDB1600362Q / 171060302

MagI³C Power Module
VDRM – Variable Step Down Regulator Module

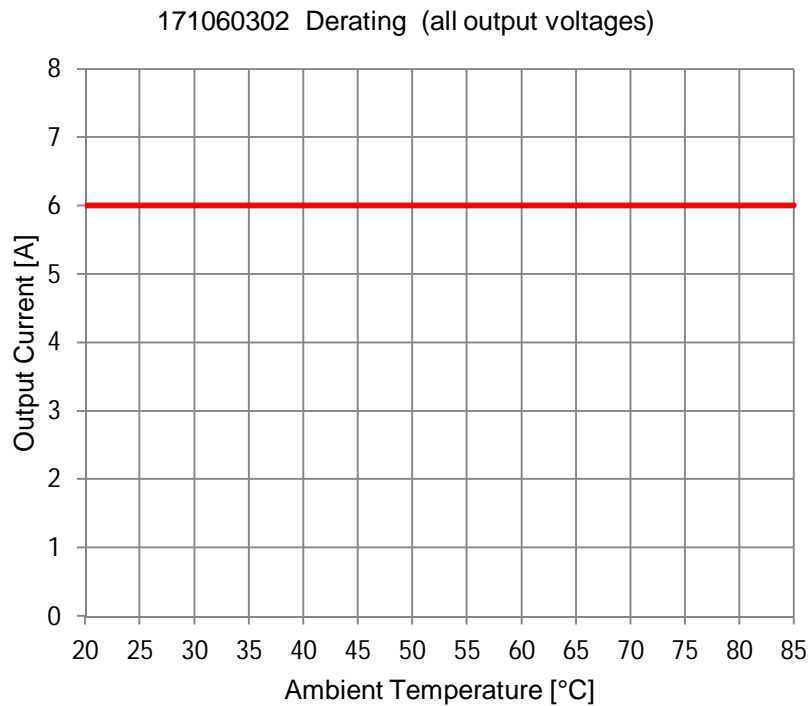
**OUTPUT POWER DERATING**

Note : see T_A limits in operating conditions on page 6.

WPMDB1600362Q / 171060302

MagI³C Power Module
 VDRM – Variable Step Down Regulator Module



OUTPUT VOLTAGE RIPPLE

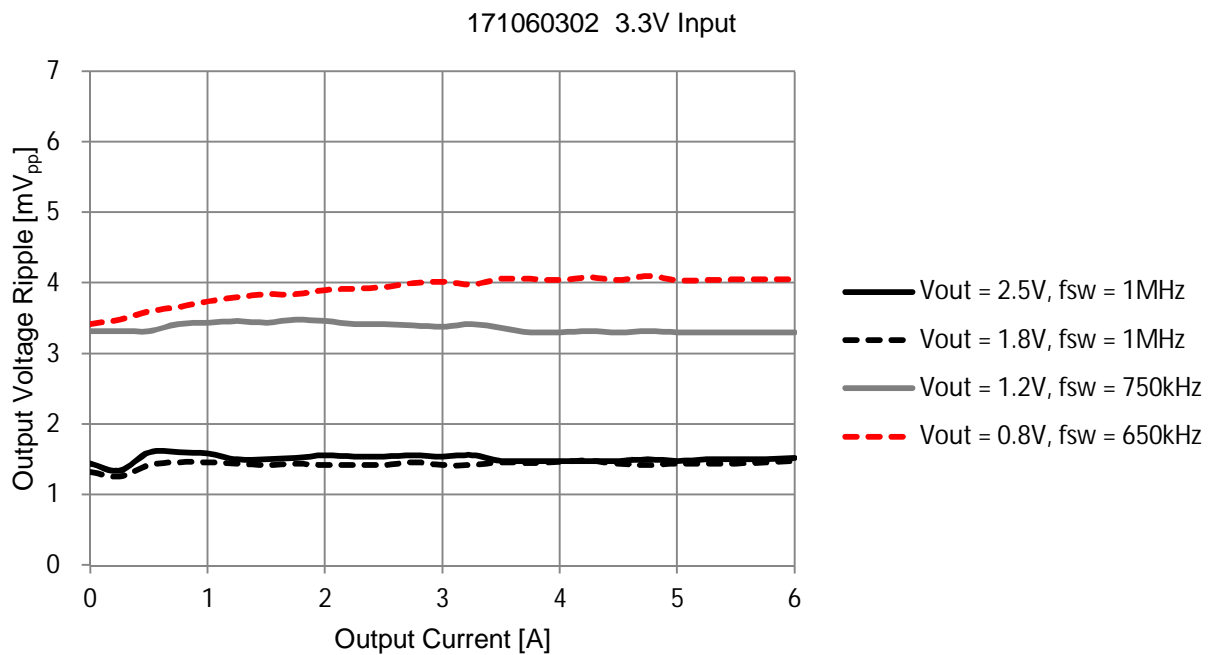
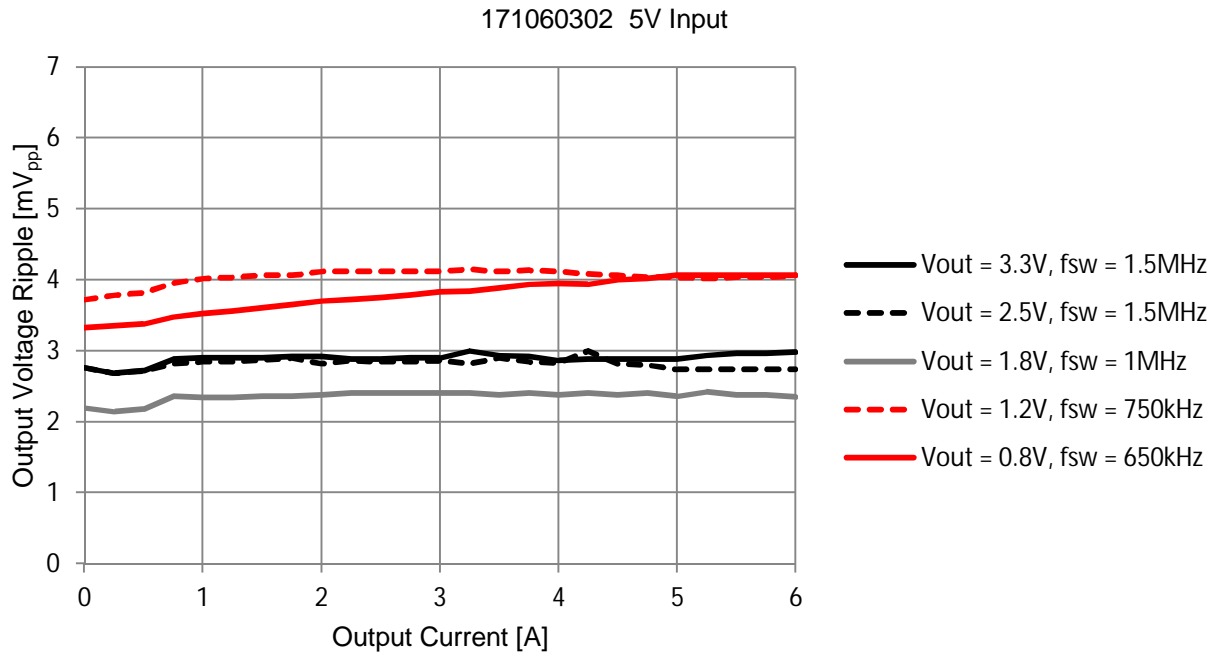

WPMDB1600362Q / 171060302

MagI³C Power Module
VDRM – Variable Step Down Regulator Module



LIGHT LOAD OPERATION

The 171060302 forces the CCM (Continuous Conduction Mode) operation at light load (forced CCM). The inductor current during t_{OFF} can flow in the opposite direction, i.e. from the output capacitor and load to ground, through the low side MOSFET. In this way during t_{OFF} the output capacitor is discharged and loses the excess of charge gathered during t_{ON} .

In this way the switching frequency always remains constant, giving a relevant advantage in terms of filtering and avoiding interferences in undesired frequency ranges. Any load change will simply shift the inductor current up and down (see figure below).

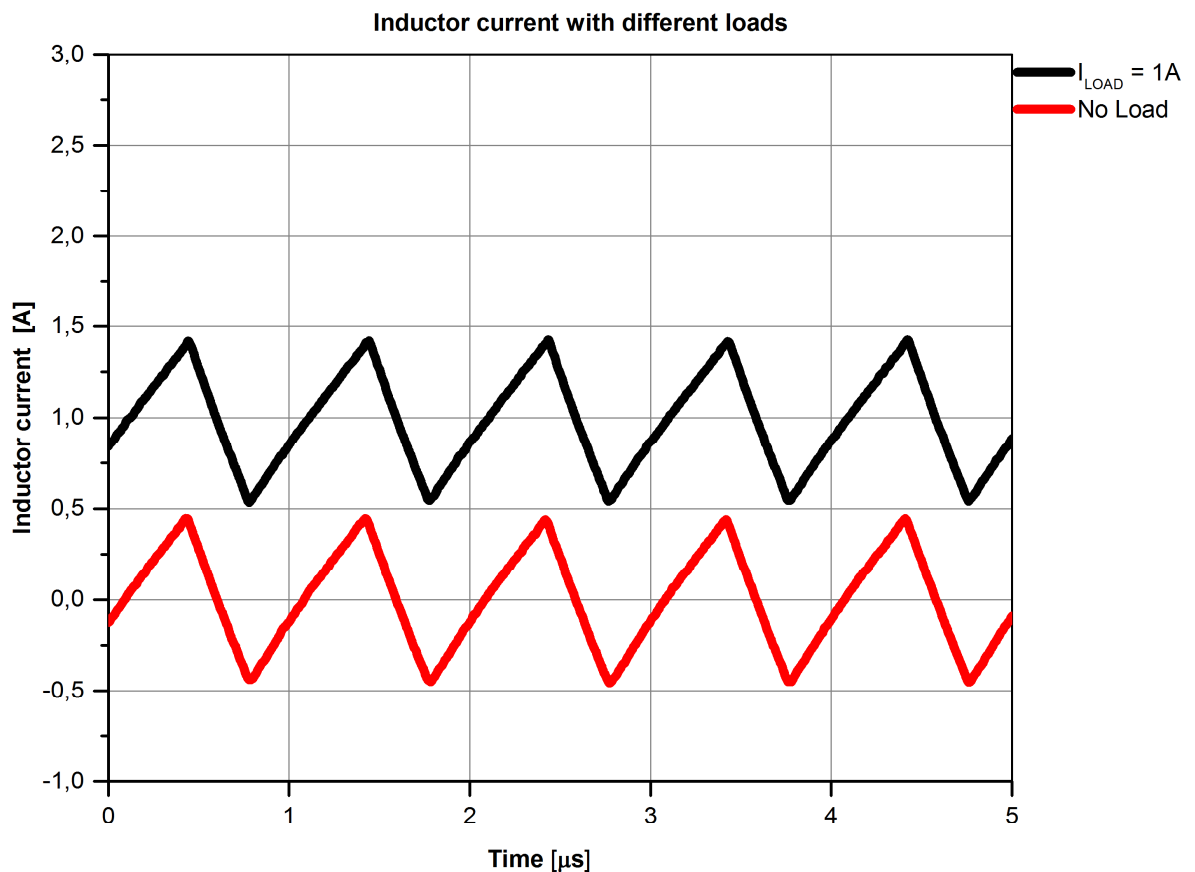

WPMDB1600362Q / 171060302

Magl³C Power Module
VDRM – Variable Step Down Regulator Module

**OUTPUT VOLTAGE RIPPLE AT LIGHT LOAD**

In addition, the forced CCM implemented by the 171060302 keeps the output voltage ripple constant and low at all conditions (see figure below).

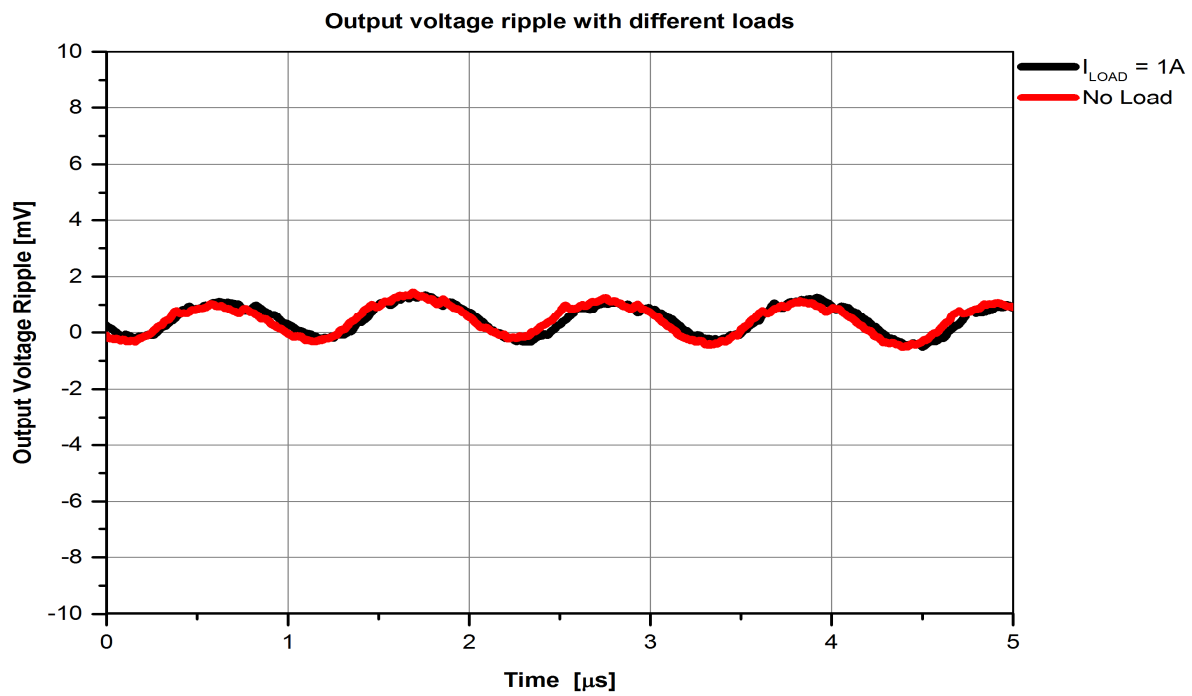

WPMDB1600362Q / 171060302

MagI³C Power Module
VDRM – Variable Step Down Regulator Module

BLOCK DIAGRAM

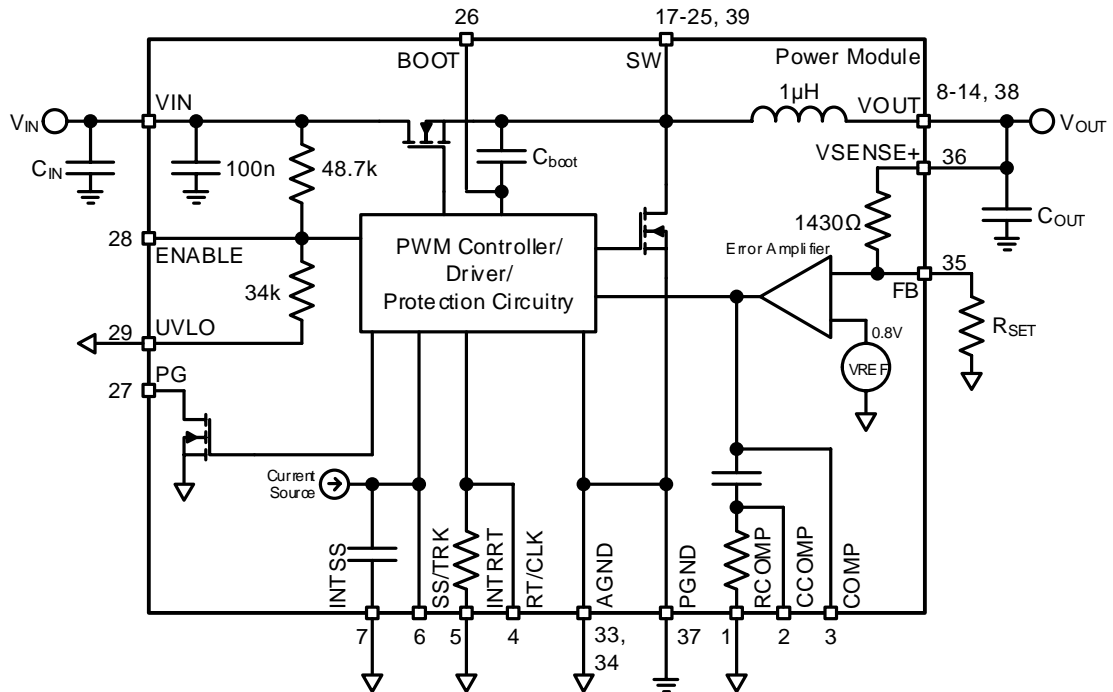

CIRCUIT DESCRIPTION

The MagI³C Power Module series 1710x0302 is based on a synchronous step down regulator with integrated MOSFETs and a power inductor. The control scheme is based on a Current Mode (CM) regulation loop.

The V_{OUT} of the regulator is divided with the feedback resistor network of internal 1430Ω and external R_{SET} and fed into the FB pin. The error amplifier compares this signal with the internal $0.803V$ reference. The error signal is amplified and controls the on-time of a fixed frequency pulse width generator. This signal drives the power MOSFETs.

The Current Mode architecture features a constant frequency during load steps. Only the on-time is modulated. It is internally compensated and stable with low ESR output capacitors and requires no external compensation network.

This architecture supports fast transient response and very small output ripple values (less than $10mV$) are achieved.

WPMDB1600362Q / 171060302

MagI³C Power Module VDRM – Variable Step Down Regulator Module



DESIGN FLOW

The next 10 simple steps will show how to select the external components to design your power application.

Essential Steps

1. Set output voltage
2. Set operating frequency
3. Select input capacitor
4. Select output capacitor

Optional Steps

5. Select soft-start capacitor
6. Select undervoltage lockout divider
7. Enable / Disable
8. Voltage tracking
9. Synchronization to an external clock
10. Power Good

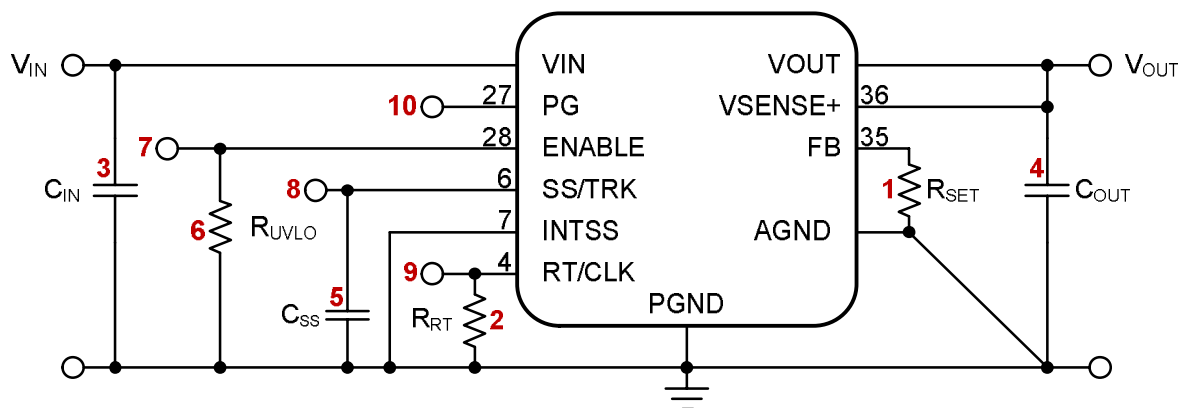

WPMDB1600362Q / 171060302

MagI³C Power Module
VDRM – Variable Step Down Regulator Module



Step 1 Setting the output voltage (V_{OUT})

The output voltage is selected with a resistor divider across FB pin and AGND. The upper resistor of 1430 Ω of the feedback voltage resistor divider is located inside the module. The output voltage adjustment range is from 0.8V to 3.6V.

$$R_{SET} = \frac{V_{REF} * 1430\Omega}{V_{OUT} - V_{REF}} (\Omega) \quad (1)$$

V_{REF} is the internal reference voltage (0.8V).

V_{OUT}	3.3V	3.0V	2.5V	1.8V	1.5V	1.2V	1.0V	0.8V
R_{SET} (E96)	453 Ω	523 Ω	665 Ω	1130 Ω	1620 Ω	2870 Ω	5620 Ω	open

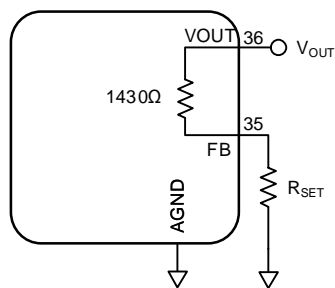

WPMDB1600362Q / 171060302

MagI³C Power Module VDRM – Variable Step Down Regulator Module



Step 2 Setting the operating frequency (f_{sw})

The switching frequency must be selected according to the input voltage, output voltage and load current for the best performance in loop regulation and transient response.

Note: R_{RT} open ($f_{sw} = 500$ kHz) is only allowed under specific conditions (see table below)!

OPERATING FREQUENCY [kHz]	R_{RT} [k Ω]	$V_{IN} = 5V$		$V_{IN} = 3.3V$	
		$I_{OUT} = 0$ to 6A		$I_{OUT} = 0$ to 6A	
		V_{OUT} RANGE [V]		V_{OUT} RANGE [V]	
		MIN	MAX	MIN	MAX
500	open	0.8	1.8	0.8	2.5
550	3400	0.8	2.2	0.8	2.5
600	1800	0.8	3.3	0.8	2.5
650	1200	0.8	3.6	0.8	2.5
700	887	0.8	3.6	0.8	2.5
750	715	0.9	3.6	0.8	2.5
800	590	0.9	3.6	0.8	2.5
850	511	1.0	3.6	0.8	2.5
900	442	1.0	3.6	0.8	2.5
950	392	1.1	3.6	0.8	2.5
1000	348	1.1	3.6	0.8	2.5
1250	232	1.4	3.6	0.9	2.4
1500	174	1.7	3.5	1.1	2.3
1750	137	2.0	3.4	1.3	2.3
2000	113	2.2	3.3	1.4	2.2

WPMDB1600362Q / 171060302

MagI³C Power Module VDRM – Variable Step Down Regulator Module



Step 3 Select input capacitor (C_{IN})

The energy at the input of the power module is stored in the input capacitor. A small input capacitor (100nF) is integrated inside the 1710x0302 MagI³C Power Module series, ensuring good EMI performance. Additional input capacitance is required external to the power module to provide cycle-by-cycle switch current and to support load transients. The external input capacitors must be placed directly at VIN pin. The input capacitor can be several capacitors in parallel. Input capacitor selection is generally directed to satisfy the input ripple current requirements rather than by capacitance value. Input ripple current rating is dictated by the equation:

$$I_{C_{IN}RMS} \approx \frac{1}{2} * I_{OUT} * \sqrt{\frac{D}{1-D}} \quad (2) \quad \text{where } D \approx \frac{V_{OUT}}{V_{IN}}$$

As a point of reference, the worst case ripple current will occur when the module is presented with full load current and when $V_{IN} = 2 \times V_{OUT}$.

Recommended minimum input capacitance is 47µF X7R or X5R ceramic with a voltage rating at least 25% higher than the maximum applied input voltage for the application. It is also recommended that attention be paid to the voltage and temperature deratings of the capacitor selected. It should be noted that ripple current rating of ceramic capacitors may be missing from the capacitor data sheet and you may have to contact the capacitor manufacturer for this rating.

If the system design requires a certain minimum value of peak-to-peak input ripple voltage (ΔV_{IN}) then the following equation may be used:

$$C_{IN} \geq \frac{I_{OUT} * D * (1-D)}{f_{SW_{CCM}} * \Delta V_{IN}} \quad (3) \quad \text{where } D \approx \frac{V_{OUT}}{V_{IN}} \quad \text{CCM} = \text{continuous conduction mode}$$

Additional bulk capacitance with higher ESR may be required to damp any resonant effects of the input capacitance and parasitic inductance of the incoming supply lines.

WPMDB1600362Q / 171060302

MagI³C Power Module
VDRM – Variable Step Down Regulator Module



Step 4 Select output capacitor (C_{OUT})

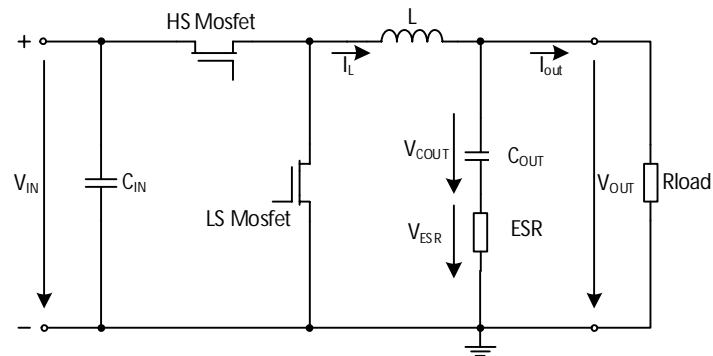

None of the required output capacitors are integrated within the module. The output capacitor must meet the worst case RMS current rating of $0.5 * \Delta I_L$, as calculated in equation (4).

$$\Delta I_L = \frac{V_{OUT} * (V_{IN} - V_{OUT})}{f_{SW} * L * V_{IN}} \quad (4)$$

Selection by output voltage ripple requirements

The capacitor should be selected in order to minimize the output voltage and provide a stable voltage at the output. Under steady state conditions, the voltage ripple observed at the output can be defined as:

$$V_{OUT \text{ ripple}} = \Delta I_L * ESR + \Delta I_L * \frac{1}{8 * f_{SW} * C_{OUT}} \quad (5)$$

Very low ESR capacitors, like ceramic and polymer electrolytic, are recommended. If a low ESR capacitor is selected, equation (4) can be simplified and a first condition for the minimum capacitance value can be derived:

$$C_{OUT} \geq \frac{\Delta I_L}{8 * V_{OUT \text{ ripple}} * f_{SW}} \quad (6)$$

Beyond that, additional capacitance will reduce output ripple as long as the ESR is low enough to permit it. Please consider the derating of the nominal capacitance value due to temperature, aging and applied DC voltage (only for MLCC, e.g. X7R up to -50%).

WPMDB1600362Q / 171060302

MagI³C Power Module
VDRM – Variable Step Down Regulator Module



The use of very low ESR capacitors leads to an output voltage ripple as shown below:

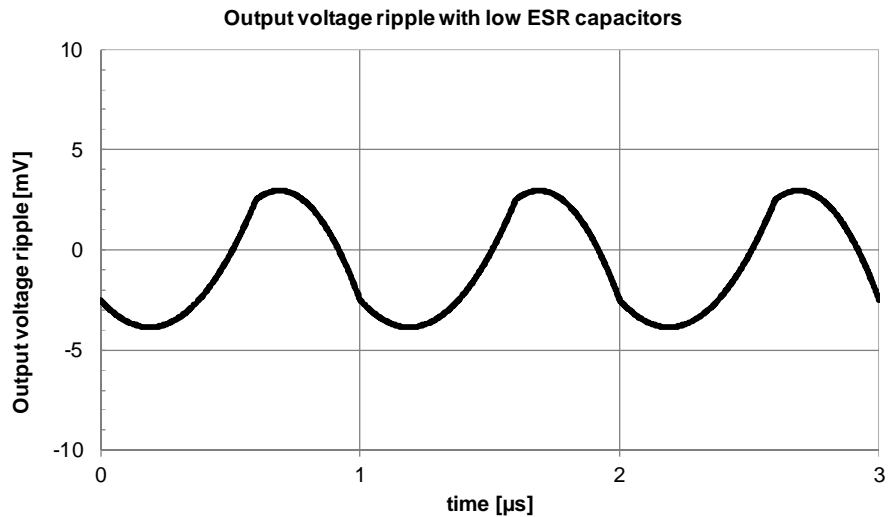

When capacitors with slightly higher ESR are utilized, the dominant parameter which influences the output voltage ripple is just the ESR:

$$ESR \leq \frac{V_{OUT \text{ ripple}}}{\Delta I_L} \quad (7)$$

Consequently the shape of the output voltage ripple changes, as shown below:

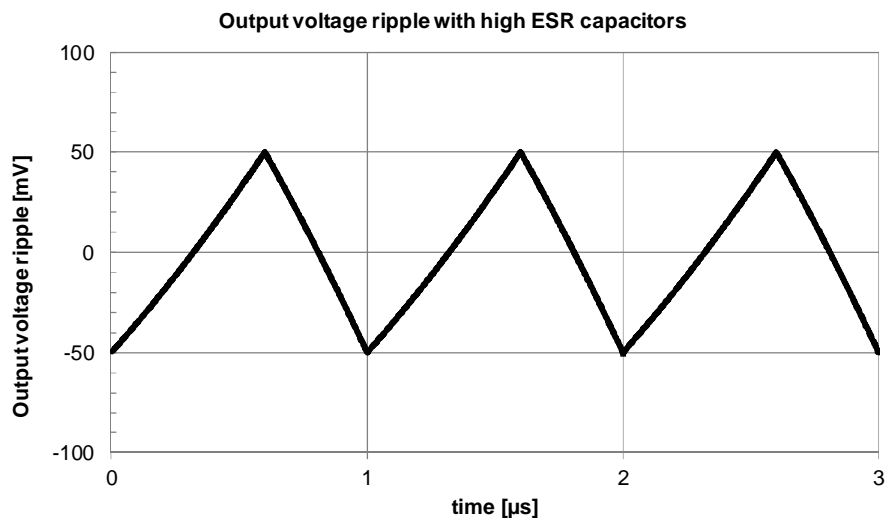

WPMDB1600362Q / 171060302

MagI³C Power Module
VDRM – Variable Step Down Regulator Module



Selection by load step requirements

The output voltage is also affected by load transients (see picture below).

When the output current transitions from a low to a high value, the voltage at the output capacitor (V_{OUT}) drops. This involves two contributing factors. One is caused by the voltage drop across the ESR (V_{ESR}) and depends on the slope of the rising edge of the current step (t_{rise}). For low ESR values and small load currents, this is often negligible. It can be calculated as follows:

$$V_{ESR} = ESR * \Delta I_{OUT} \quad (8)$$

Where ΔI_{OUT} is the load step, as shown in the picture below (simplified: no voltage ripple is shown).

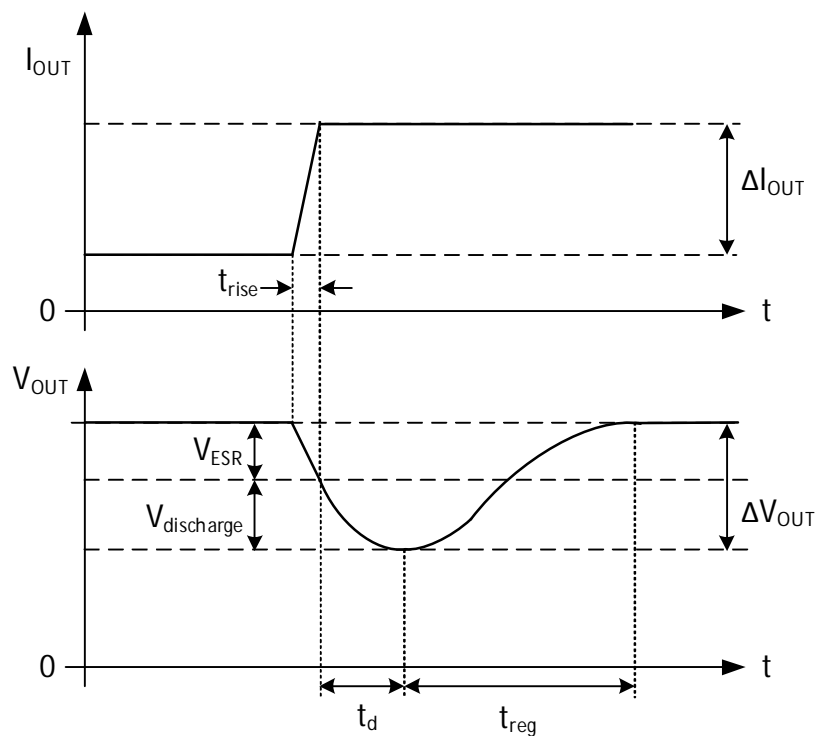

The second contributing factor is the voltage drop due to discharge of the output capacitor, which can be estimated as:

$$V_{discharge} = \frac{\Delta I_{OUT} \cdot t_d}{2 \cdot C_{OUT}} \quad (9)$$

In a current mode architecture the t_d is strictly related to the bandwidth of the regulation loop and influenced by the C_{OUT} (increasing C_{OUT} , the t_d increases as well).

WPMDB1600362Q / 171060302

MagI³C Power Module
VDRM – Variable Step Down Regulator Module

In order to choose the value of the output capacitor, the following steps should be utilized:

1. According to the operating conditions (V_{IN} , V_{OUT} and f_{sw}), select the minimum C_{OUT} recommended in table on page 35.
2. Measure t_d .
3. Calculate the appropriate value of C_{OUT} for the maximum voltage drop $V_{discharge}$ allowed at a defined load step, using the following equation (10), derived from equation (9):

$$C_{OUT} \geq \frac{\Delta I_{OUT} \cdot t_d}{2 \cdot V_{discharge}} \quad (10)$$

4. As above mentioned, changing C_{OUT} affects also t_d . Therefore a new measure should be performed and, if necessary, the step 2 and 3 should be repeated (it is an iterative process and few steps could be required).

Example. $V_{IN} = 5V$, $V_{OUT} = 3.3V$, $\Delta I_{OUT} = 5A$, $f_{sw} = 1.5MHz$, $\Delta V_{OUT} < 0.25V$.

According to the table on page 35, three MLCC of $47\mu F$ at the output would be necessary. After mounting these capacitors, the load transient should be performed and the t_d measured (see picture below).

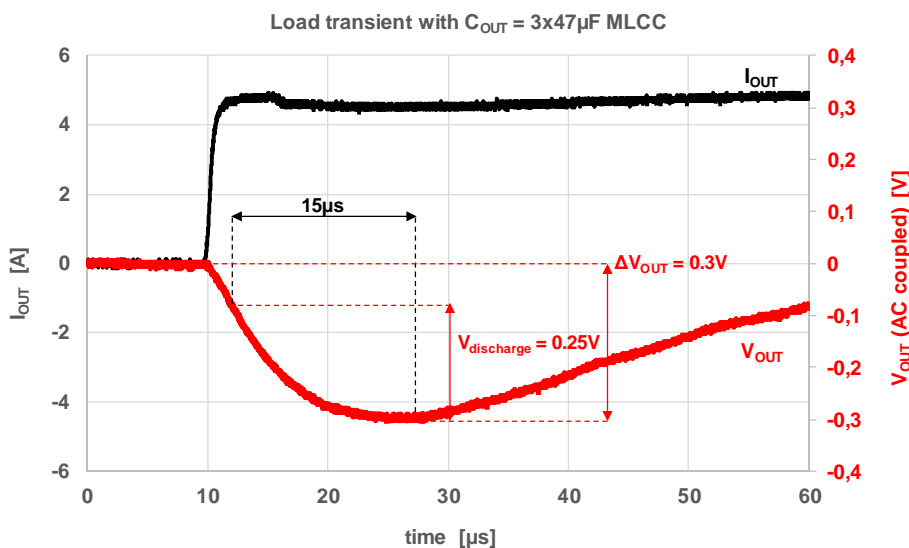

The $\Delta V_{OUT} = 0.3V$ and $t_d = 15\mu s$. It is important to remind that the ΔV_{OUT} includes also the voltage drop during trise, mainly due to the ESR ($V_{ESR} = 50mV$, see picture above). In order to achieve the desired maximum ΔV_{OUT} , the $V_{discharge}$ should be below $0.15V$. Using the equation (9), the minimum required output capacitor is:

$$C_{OUT} \geq \frac{5A \cdot 15\mu s}{2 \cdot 0.15V} = 250\mu F$$

To achieve the calculated value of C_{OUT} an additional electrolytic capacitor of $150\mu F$ is mounted in parallel (considering the lower effective capacitance due to DC biasing).

WPMDB1600362Q / 171060302

MagI³C Power Module
VDRM – Variable Step Down Regulator Module

Nevertheless, as indicated in point 4, one or more measurements should be performed in order to find the most suitable value of C_{OUT} . After some iterations, the most suitable output capacitance is determined. Due to its high value, a combination of three MLCC ($47\mu\text{F}$ each one) and an electrolytic capacitor ($220\mu\text{F}$) is implemented. The final result is shown in the picture below:

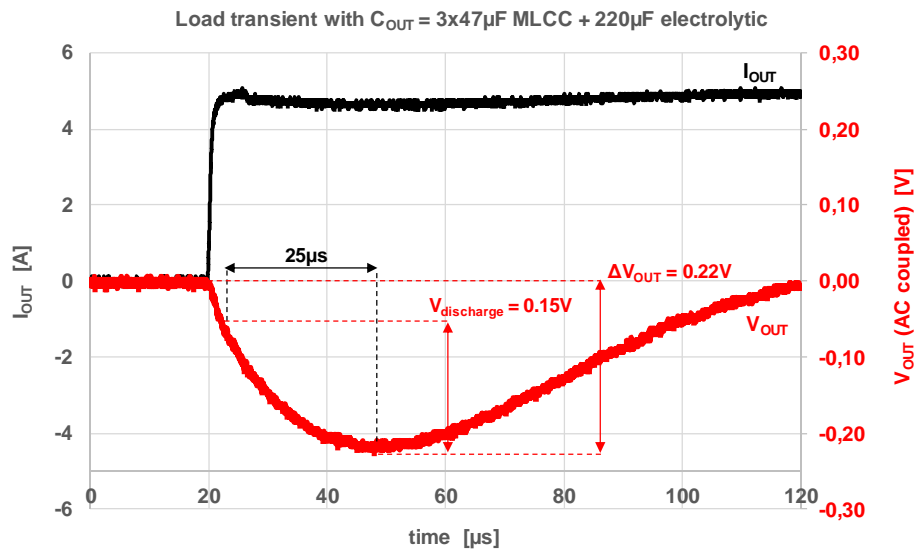

WPMDB1600362Q / 171060302

MagI³C Power Module
VDRM – Variable Step Down Regulator Module



Step 5 Select soft-start capacitor (C_{SS})

Connecting the INTSS pin to AGND and leaving SS/TRK pin open enables the internal soft-start capacitor with a soft-start interval of approximately 1 ms. Adding additional capacitance between the SS/TRK pin and AGND increases the soft-start time according to the table below. There is no maximum value limit for C_{SS}.

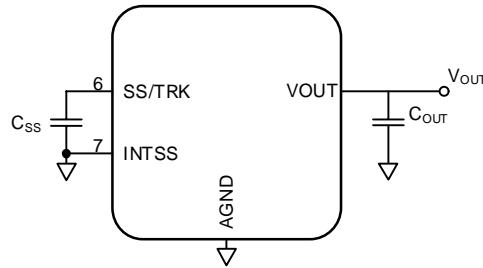

C _{SS} [nF]	Open	2.2	4.7	10	15	22	27
Soft-start [ms]	~1	~2	~3	~4	~6	~9	~10

The values in the table have been measured at room temperature under full load condition and gives an indication of the soft-start duration.

The diagram below illustrates how the slope of the output voltage changes according to the different soft-start settings. It is important to highlight that the implementation of the soft-start (also without the external C_{SS}, a default soft-start capacitor is internally present) prevents the output voltage from experiencing overshoots.

Output voltage at start up with different soft-start capacitors - V_{IN} = 5V, V_{OUT} = 3.3V

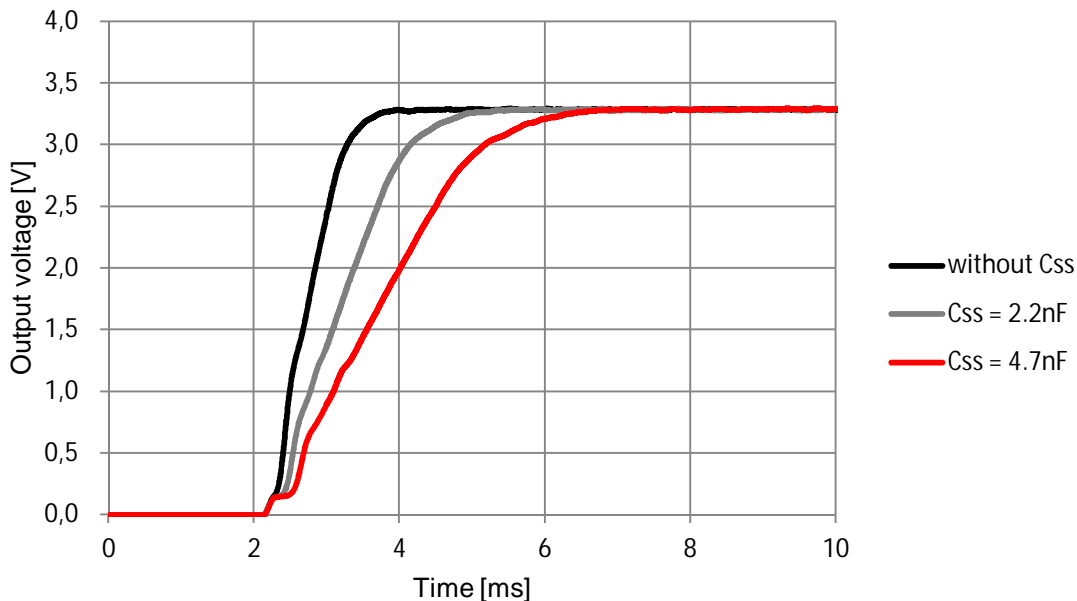

WPMDB1600362Q / 171060302

MagI³C Power Module VDRM – Variable Step Down Regulator Module



The curves below show a comparison among the input currents under three different soft-start conditions:

- Default soft-start (without any additional external capacitor)
- Soft-start with two different values of C_{SS} .

The first peak (same for any condition) is due to the initial charge of the capacitors at the input (C_{IN}). This current peak is not affected by the soft-start. Therefore it can't be reduced by different soft-start capacitor values.

The right part of the diagram shows the smooth rise of the input current during the start-up. The different slope of the rising edge of the currents is defined by the different soft-start durations.

Input current at start up with different soft-start capacitors - $V_{IN} = 5V$

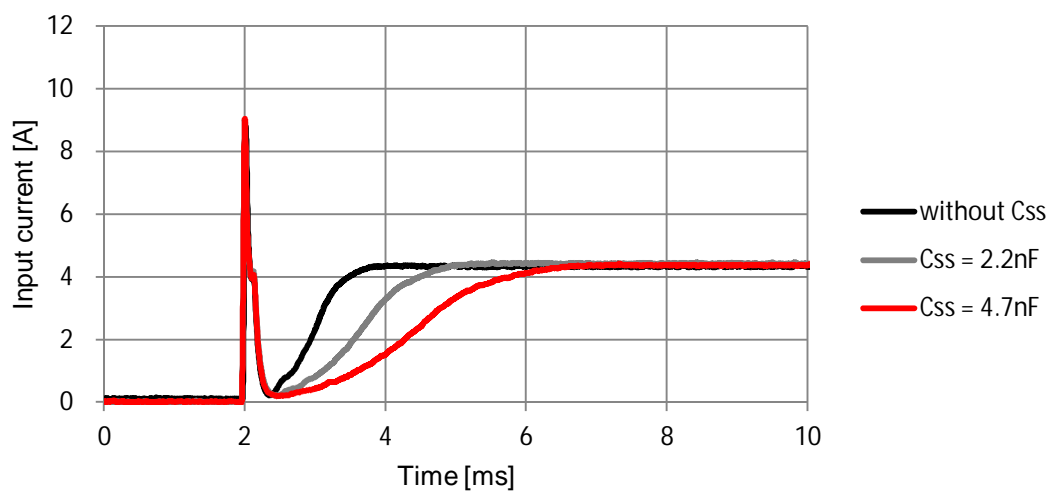

WPMDB1600362Q / 171060302

Magi³C Power Module
VDRM – Variable Step Down Regulator Module



Step 6 Select undervoltage lockout divider

Pin 29 connected to analog ground

This connects the internal undervoltage lockout resistor divider. The enable rising threshold is typ. 1.25V. The enable falling threshold is at 1V max. Use at least 10% safety tolerance. For 3.3V input voltage use a rising threshold below 3V. This threshold is attainable by leaving pin 29 open. An external undervoltage lockout resistor will set the rising threshold below 3V.

$V_{IN(UVLO)}$ rising threshold typ. [V]	3.14V
Hysteresis [mV]	300

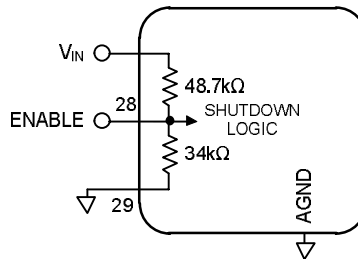

Pin 29 connected to AGND with additional resistor to adjust undervoltage lockout.

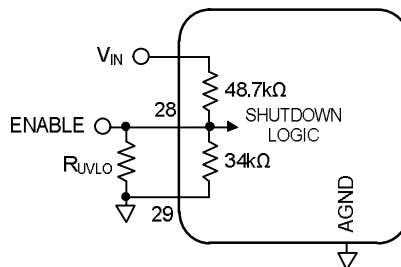

$V_{IN(UVLO)}$ rising threshold typ. [V]	3.25	3.5	3.75	4.0	4.25	4.5	4.75
R_{UVLO} [kΩ]	294	133	86.6	63.4	49.9	42.2	35.7
Hysteresis [mV]	325	335	345	355	365	375	385

WPMDB1600362Q / 171060302

MagI³C Power Module
VDRM – Variable Step Down Regulator Module

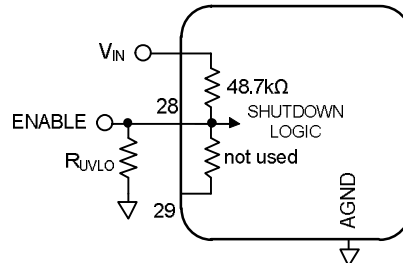

Pin 29 open with additional resistor to adjust undervoltage lockout for lower values.



$V_{IN(UVLO)}$ rising threshold typ. [V]	3.0	2.75	2.5	2.25
R_{UVLO} [kΩ]	34.0	39.7	47.5	60.4
Hysteresis [mV]	170	156	142	126

Step 7 Enable

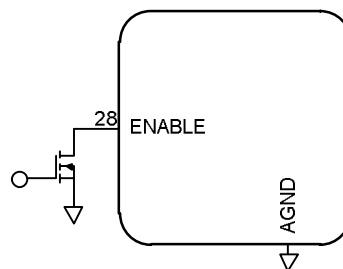
The ENABLE pin provides electrical on/off control of the device. Once the ENABLE pin voltage exceeds the threshold voltage, the device starts operation. If the ENABLE pin voltage is pulled below the threshold voltage, the regulator stops switching and enters low quiescent current state. Apply a voltage $\leq 1V$ to the enable pin to disable the device. Left open or set to $\geq 1.5V$ will enable the device. When manually disabling during lab tests, use short leads to connect to AGND of the module. If the logic driver is not close to the ENABLE pin of the module, use a transistor (as shown below) to prevent the noise from disturbing the proper ENABLE/DISABLE function.



WPMDB1600362Q / 171060302

MagI³C Power Module
VDRM – Variable Step Down Regulator Module



Step 8 Voltage sequencing & tracking

Sequencing

Many of the common power supply sequencing methods can be implemented using the SS/TRK, ENABLE and PG pins. The sequential voltage tracking is illustrated below using two devices. The PG pin of the first device is connected to the ENABLE pin of the second device which enables the second power supply once the primary supply reaches regulation. Both modules can apply different slopes of the output voltage during start by selecting the individual soft-start capacitors accordingly.

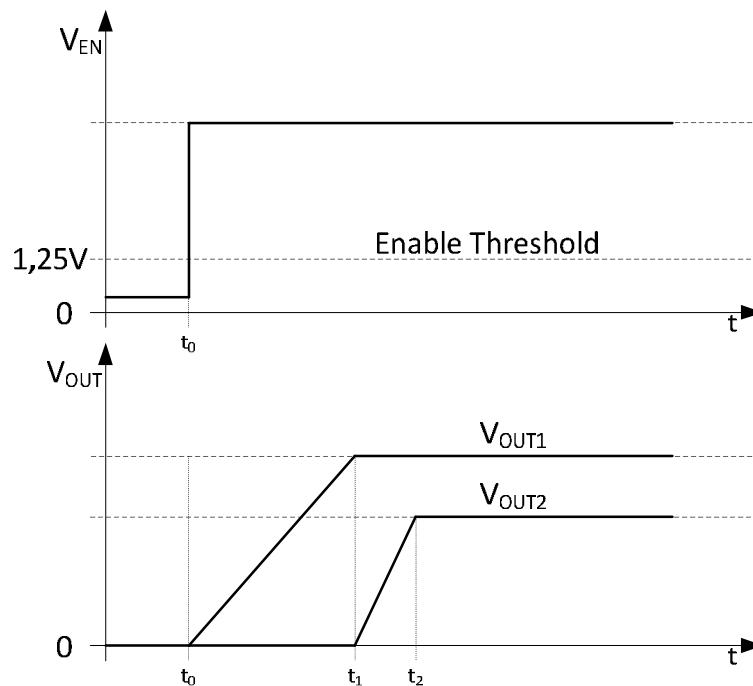
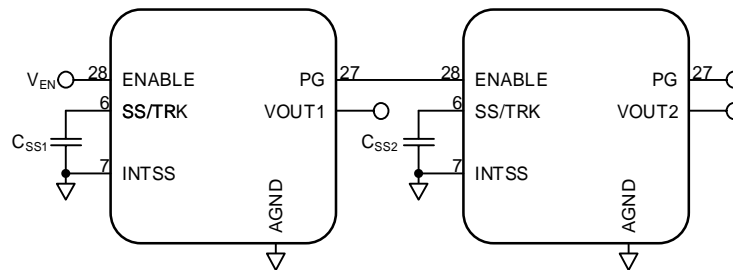

WPMDB1600362Q / 171060302

MagI³C Power Module
VDRM – Variable Step Down Regulator Module



Simultaneous tracking

Simultaneous power supply sequencing can be implemented by connecting the resistor network of R₁ and R₂ as shown below to the output of the power supply that needs to be tracked or to another voltage reference source.

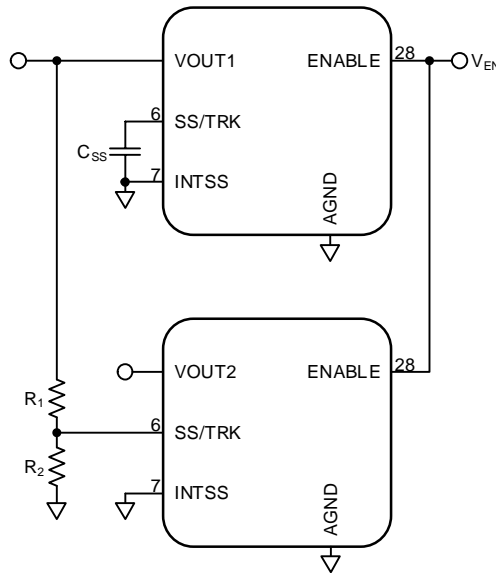

$$R_1 = \frac{V_{OUT2} * 12.6}{V_{REF}} \text{ (k}\Omega\text{)} \quad (10)$$

$$R_2 = \frac{V_{REF} * R_1}{V_{OUT2} - V_{REF}} \text{ (k}\Omega\text{)} \quad (11)$$

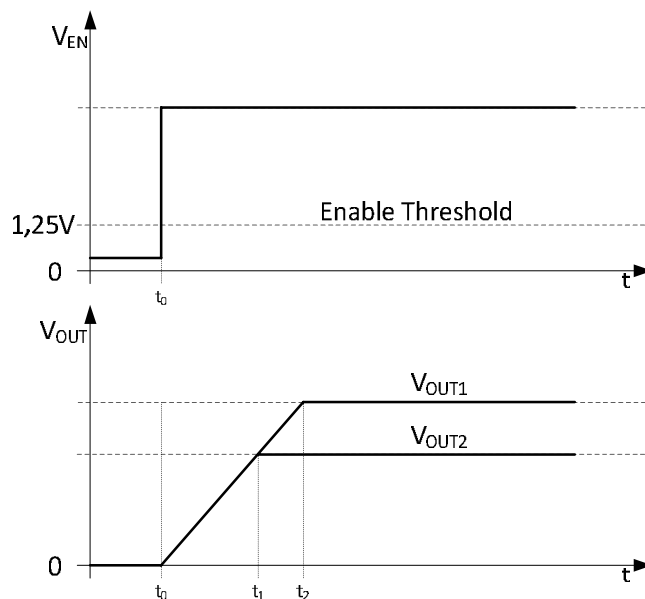

WPMDB1600362Q / 171060302

MagI³C Power Module VDRM – Variable Step Down Regulator Module



Step 9 Synchronizing with an external clock

An internal phase locked loop (PLL) has been implemented to allow synchronization between 500 kHz and 2 MHz, and to easily switch from RT mode to CLK mode. To implement the synchronization feature, connect a square wave clock signal to the RT/CLK pin with a minimum pulse width of 75 ns. The maximum clock pulse width must be calculated using Equation 9. The clock signal amplitude must transition lower than 0.4 V and higher than 2.2 V. The start of the switching cycle is synchronized to the falling edge of RT/CLK pin. For applications requiring both RT mode and CLK mode, configure the device as shown in the figure below. Before the external clock is present, the device works in RT mode and the switching frequency is set by the RT resistor (R_{RT}). When the external clock is present, the CLK mode overrides the RT mode. The device switches from RT mode to CLK mode and the RT/CLK pin becomes high impedance as the PLL starts to lock onto the frequency of the external clock. The device will lock to the external clock frequency approximately 15 μ s after a valid clock signal is present. It is not recommended to switch from CLK mode back to RT mode because the internal switching frequency drops to a lower frequency before returning to the switching frequency set by the RT resistor.

$$\text{Maximum clock pulse width} = \frac{0.75 * \left(1 - \frac{V_{OUT}}{V_{INMIN}}\right)}{f_{SW}} \quad (12)$$

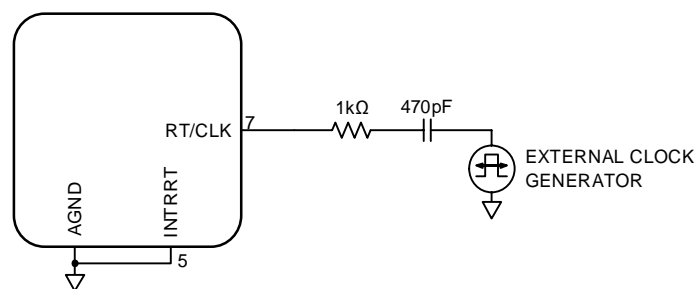

Step 10 Power Good

The PG pin is an open drain output. Once the voltage on the SENSE+ pin is between 93% and 107% of the nominal value, the PG pin pull-down is released and the pin floats. The recommended pull-up resistor value is between 10 k Ω and 100 k Ω to a voltage source that is 6 V or less. The PG pin is in a defined state once V_{IN} is greater than 1.2 V, but with reduced current sinking capability. The PG pin achieves full current sinking capability once the V_{IN} pin is above 2.95V. The PG pin is pulled low when the voltage on SENSE+ is lower than 91% or greater than 109% of the nominal set voltage. Also, the PG pin is pulled low if the input UVLO or thermal shutdown is asserted, or if the ENABLE pin is pulled low.

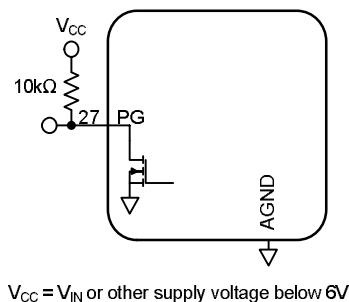

WPMDB1600362Q / 171060302

MagI³C Power Module
VDRM – Variable Step Down Regulator Module



PROTECTIVE FEATURES

Over temperature protection (OTP)

The junction temperature of the MagI³C Power Module should not be allowed to exceed its maximum ratings. Thermal protection is implemented by an internal thermal shutdown circuit which activates at 175°C (typ) causing the device to enter a low power standby state. In this state the main MOSFET remains off causing V_{OUT} to fall, and additionally the C_{SS} capacitor is discharged to ground. Thermal protection helps prevent catastrophic failures due to accidental device overheating. When the junction temperature falls below 160°C the SS pin is released, V_{OUT} rises smoothly, and normal operation resumes. Applications requiring maximum output current, especially those at high input voltages, may require additional derating at elevated temperatures.

Over current protection (OCP)

For protection against load faults, the MagI³C Power Module incorporates cycle-by-cycle current limiting (see I_{OCP} in “Electrical Specification” on page 7). During an overcurrent condition the output current is limited and the output voltage is reduced. As the output voltage drops more than 9% below the set point, the PG signal is pulled low. If the output voltage drops more than 25%, the switching frequency is reduced to reduce power dissipation within the device. When the overcurrent condition is removed, the output voltage returns to the nominal voltage.

Short circuit protection (SCP)

The short circuit protection is realized via cycle-by-cycle current limiting. The short circuit protection is continuous with a recovery at the following switching cycle if the short circuit condition is removed.

Output overvoltage protection (OVP)

The device incorporates an overvoltage protection to minimize output voltage overshoot when recovering from output fault conditions. When the output voltage reaches the upper trip point of 109% of the voltage programmed with the feedback resistor divider, the high-side MOSFET is disabled to prevent further output voltage rise caused by the module itself. When the output voltage reaches the lower trip point of 105% of the programmed output voltage, the high-side MOSFET will be turned on again at the next switching cycle.

WPMDB1600362Q / 171060302

MagI³C Power Module
VDRM – Variable Step Down Regulator Module



TYPICAL SCHEMATIC

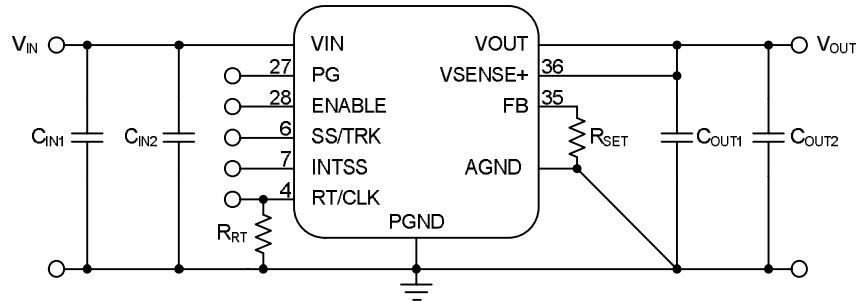

INPUT	OUTPUT	C _{IN2}	C _{IN1}	R _{RT}	R _{SET}	C _{OUT1}	C _{OUT2}
5V	3.3V	220µF	47µF X5R	174kΩ	459Ω	3x47µF X5R	-
5V	2.5V	220µF	47µF X5R	174kΩ	673Ω	3x47µF X5R	-
5V	1.8V	220µF	47µF X5R	348kΩ	1150Ω	47µF X5R	220µF
5V	1.5V	220µF	47µF X5R	348kΩ	1650Ω	47µFX5R	330µF
5V	1.2V	220µF	47µF X5R	715kΩ	2870Ω	47µF X5R	330µF
5V	1.0V	220µF	47µF X5R	715kΩ	5830Ω	47µF X5R	330µF
5V	0.8V	220µF	47µF X5R	1200kΩ	Open	47µF X5R	330µF
3.3V	1.8V	220µF	47µF X5R	348kΩ	1150Ω	47µF X5R	220µF
3.3V	1.5V	220µF	47µF X5R	348kΩ	1650Ω	47µF X5R	330µF
3.3V	1.2V	220µF	47µF X5R	715kΩ	2870Ω	47µF X5R	330µF
3.3V	1.0V	220µF	47µF X5R	715kΩ	5830Ω	47µF X5R	330µF
3.3V	0.8V	220µF	47µF X5R	1200kΩ	Open	47µF X5R	330µF

C_{IN2} and C_{OUT2} ≥ 100µF are polymer electrolytic types.

WPMDB1600362Q / 171060302

MagI³C Power Module
VDRM – Variable Step Down Regulator Module



LAYOUT RECOMMENDATION

PCB layout is an important part of DC-DC converter design. Poor board layout can interfere with the performance of a DC-DC converter and surrounding circuitry by contributing to EMI, ground bounce and resistive voltage drop in the traces. These can send erroneous signals to the DC-DC converter resulting in poor regulation or instability. Good layout can be implemented by following five simple design rules.

1: Minimize area of switched current loops

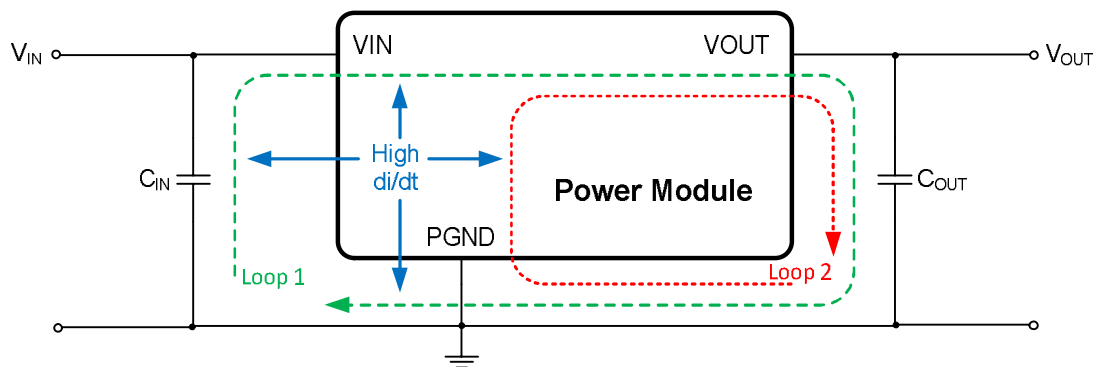

Target is to identify the paths in the system which have discontinuous current flow. They are the most critical ones because they act as an antenna and cause observable high frequency noise (EMI). The easiest approach to find the critical paths is to draw the high current loops during both switching cycles and identify the sections which do not overlap. They are the ones where no continuous current flows and high di/dt is observed. Loop1 is the current path during the ON-time of the High-Side MOSFET. Loop2 is the current path during the OFF-time of the High-Side MOSFET.

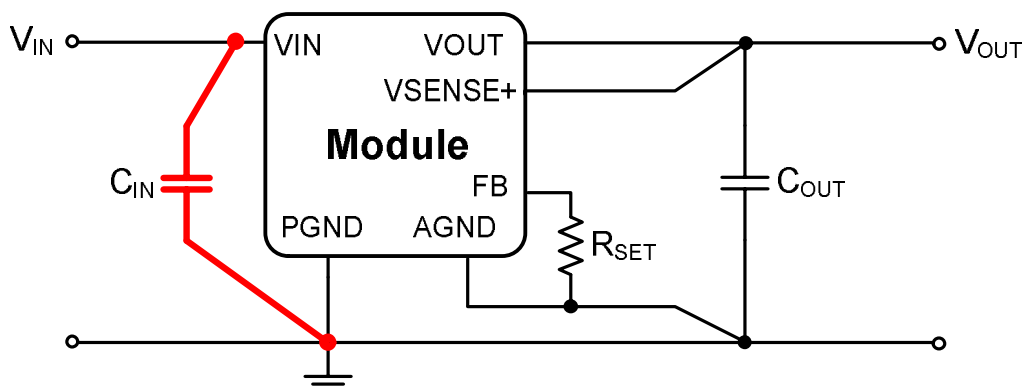

Based on those considerations, the path of the input capacitor C_{IN} is the most critical one to generate high frequency noise on V_{IN} . Therefore place C_{IN} as close as possible to the MagI³C power module V_{IN} and PGND pins. This will minimize the high di/dt area and reduce radiated EMI. Additionally, grounding for both the input and output capacitor should consist of a localized top side plane that connects to the PGND pins.

WPMDB1600362Q / 171060302

Magl³C Power Module VDRM – Variable Step Down Regulator Module



The placement of the input capacitors is highlighted in the following pictures of the evaluation board.

The positive terminal of C_{IN1} and C_{IN2} need to be very close to the VIN pins of the power module.

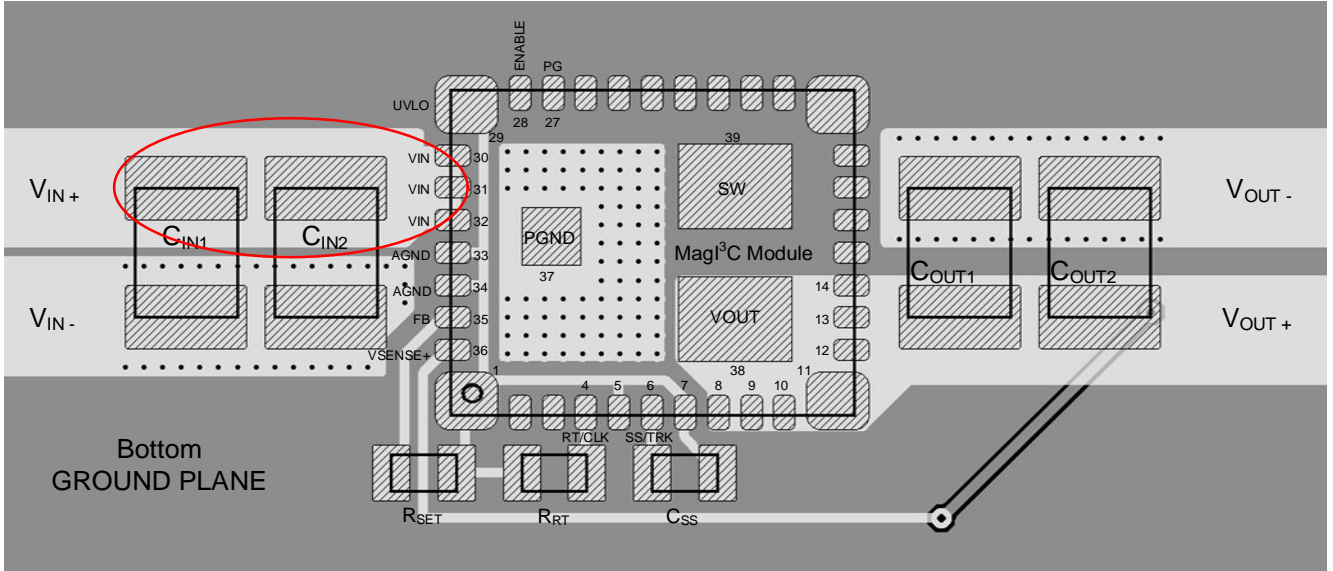

PCB color coding: Top layer Bottom layer

The negative terminal of C_{IN1} and C_{IN2} need to be very close to the PGND pad of the power module. The ground path is passing through the vias at the C_{IN} terminals and thermal vias around the PGND pad.

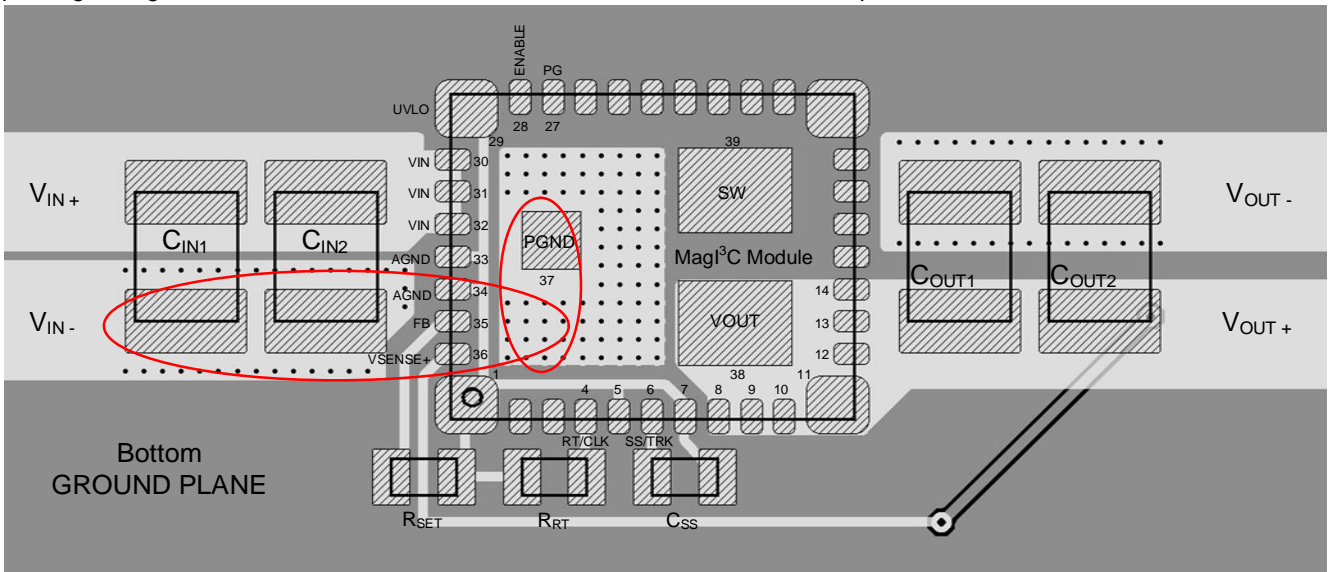

WPMDB1600362Q / 171060302

Magi³C Power Module VDRM – Variable Step Down Regulator Module



2: Analog Ground (AGND) connections

The ground connections for the clock setting resistor (R_{RT}), soft-start capacitor (SS/TRK), output voltage setting resistor (R_{SET}) and enable components should be routed to the AGND pins of the device. If not properly handled, poor grounding can result in degraded load regulation or erratic output voltage ripple behavior. Place R_{RT} , and C_{SS} close to their respective pins.

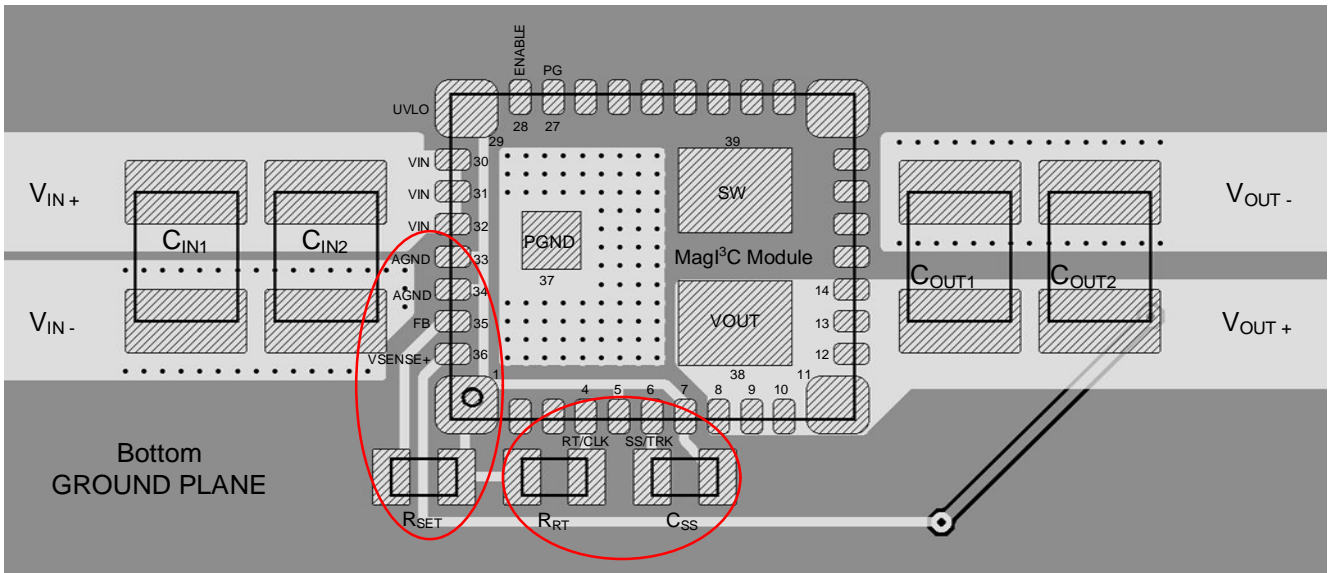

3: Analog Ground (AGND) to Power Ground (PGND) connections

The AGND is **internally connected** to PGND at a low noise node. The output ground current is flowing from the PGND pad through the ground plane through the ground terminal of the first output capacitor. Due to its very low ripple it will not inject noise in the ground plane.

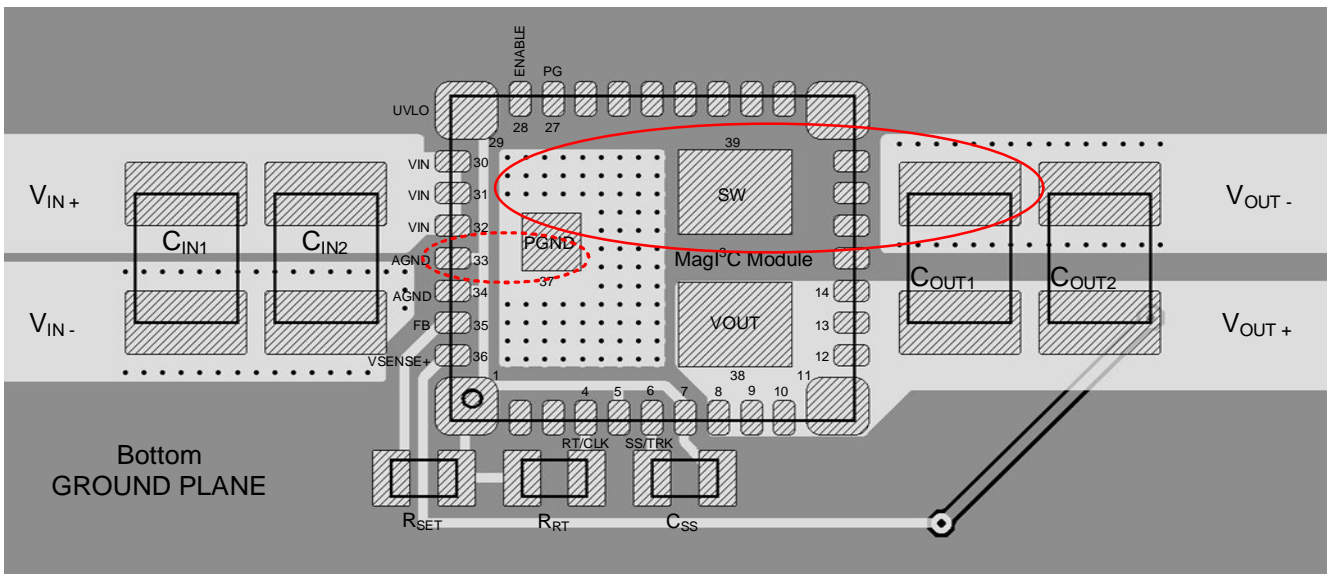

Module Internal connection:

WPMDB1600362Q / 171060302

Magl³C Power Module VDRM – Variable Step Down Regulator Module



4: Feedback layout

The feedback resistor, R_{SET} should be located close to the FB pin. Since the FB node is high impedance, maintain the trace thickness small. The traces from R_{SET} should be routed away from the body of the Magl³C power module to minimize noise pickup. Connect the feedback trace at the positive terminal of the last output capacitor (C_{OUT2}). As this is the node of lowest noise.

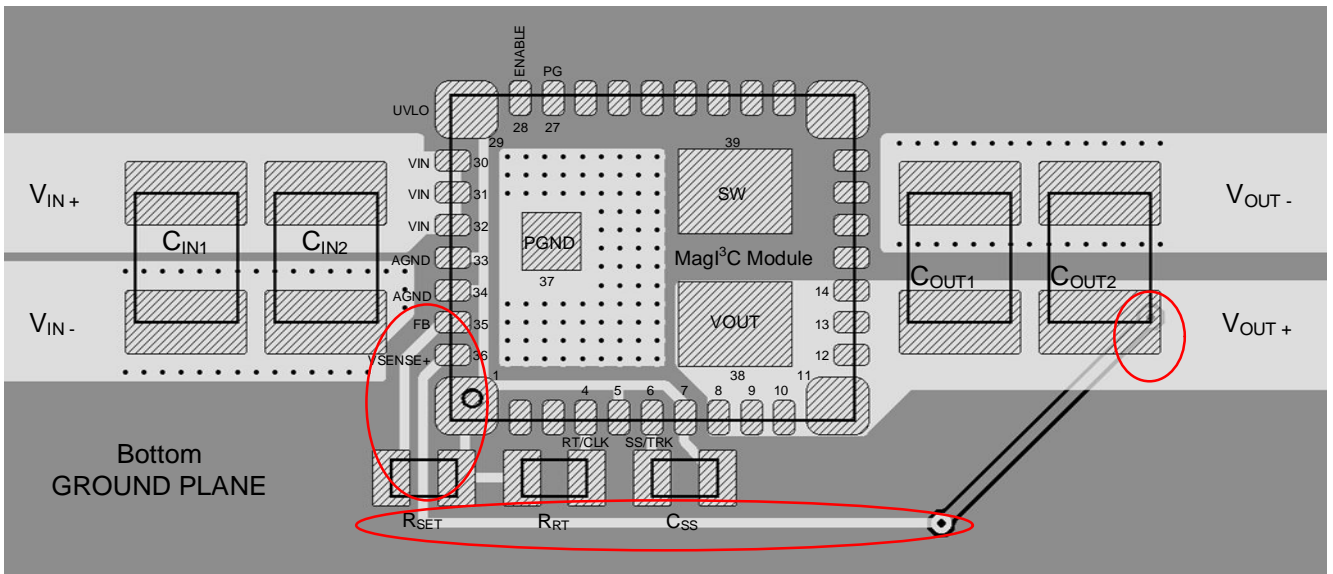

5: Make input and output bus connections as wide as possible

This reduces any voltage drops on the input or output of the converter and maximizes efficiency.

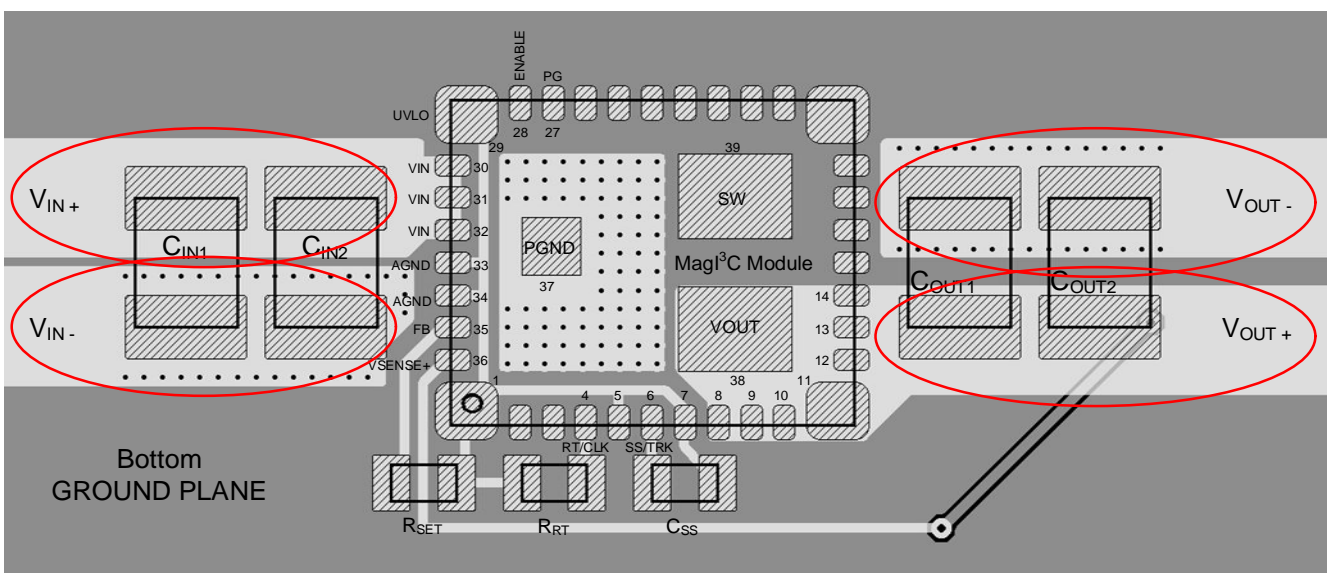

WPMDB1600362Q / 171060302

MagI³C Power Module
VDRM – Variable Step Down Regulator Module



6: Provide adequate device heat-sinking

Place a dedicated PGND copper area beneath the MagI³C Power Module.

Use an array of heat-sinking vias to connect the PGND pad to the ground plane on the bottom PCB layer. If the PCB has a plurality of copper layers, these thermal vias can also be used to make connection to inner layer heat-spreading ground planes. For best results use a via array as proposed in the picture above with via diameter of 200µm (hole: 100µm) thermal vias spaced 200µm. Ensure enough copper area is used for heat-sinking to keep the junction temperature below 125°C.

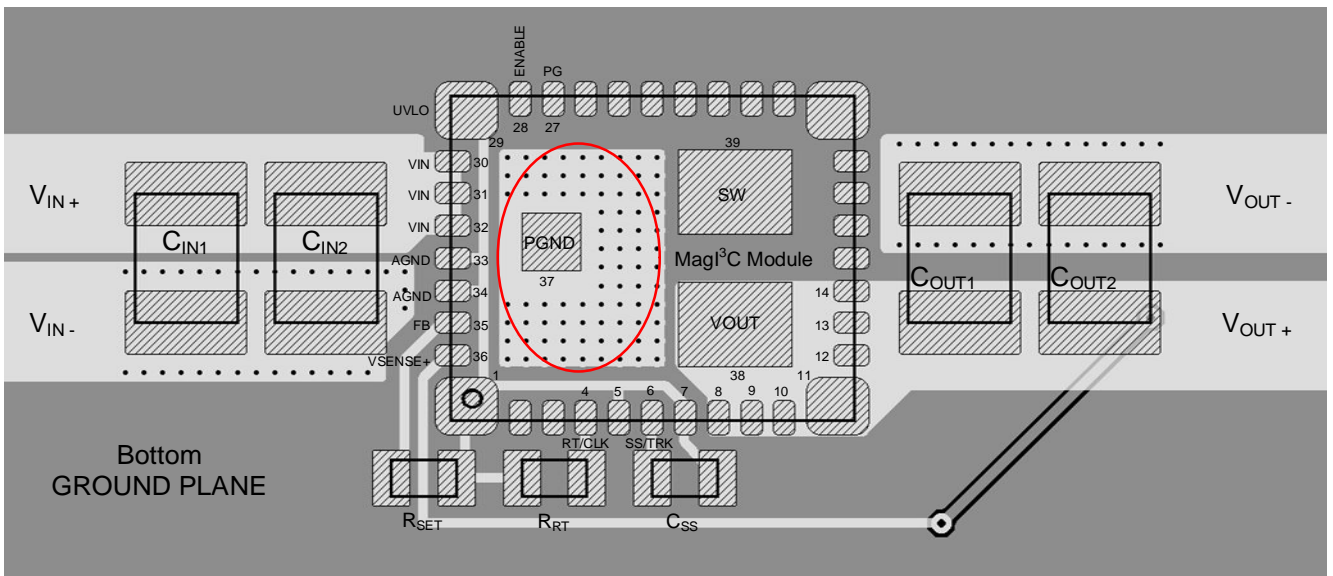

6: Isolate high noise areas

Place a dedicated solid GND copper area beneath the MagI³C Power Module.

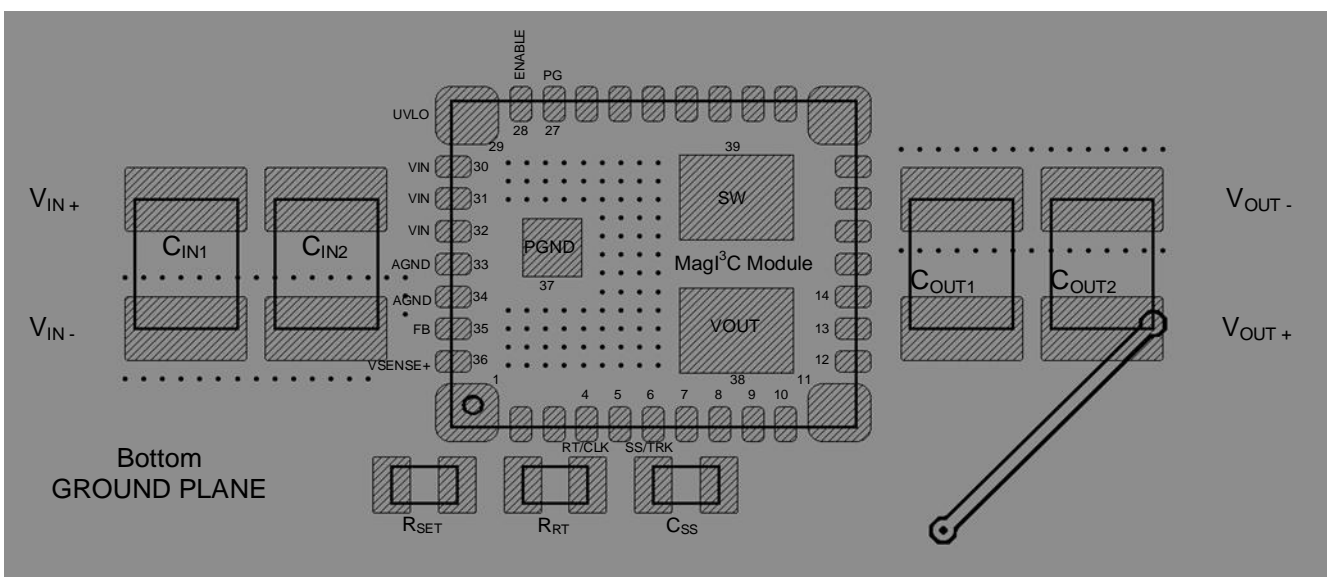

WPMDB1600362Q / 171060302

MagI³C Power Module
VDRM – Variable Step Down Regulator Module

Bill of Material

Designator	Description	Quantity	Order Code	Manufacturer
IC1	MagI ³ C Power Module	1	171060302	Würth Elektronik
C _{IN1} , C _{OUT3}	Electrolytic polymer capacitor 220µF/10V	2	875105244013	Würth Elektronik
C _{IN2} , C _{IN3} , C _{OUT1} , C _{OUT2}	Ceramic chip capacitor 47µF/10V X5R, 1210	4	885012109007	Würth Elektronik
C _{SYNC}	Ceramic chip capacitor 470pF/50V NP0/COG	1	885012007007	Würth Elektronik
LED1	LED red	1	150080SS75000	Würth Elektronik
C _{SS} , R _{UVLO}	Not mounted			
R _{SYNC}	1000Ω	1		
R1	301Ω	1		
R _{RT}	Set by jumper	1.2 MΩ for f _{SW} = 650kHz	1	
		715 kΩ for f _{SW} = 750kHz	1	
		348 kΩ for f _{SW} = 1MHz	1	
		232kΩ for f _{SW} = 1.25MHz	1	
		174kΩ for f _{SW} = 1.5MHz	1	
		113kΩ for f _{SW} = 2MHz	1	
R _{SET}	Set by jumper	5620Ω for V _{OUT} = 1.0V	1	
		2870Ω for V _{OUT} = 1.2V	1	
		1620Ω for V _{OUT} = 1.5V	1	
		1130Ω for V _{OUT} = 1.8V	1	
		665Ω for V _{OUT} = 2.5V	1	
		453Ω for V _{OUT} = 3.3V	1	

WPMDB1600362Q / 171060302

MagI³C Power Module VDRM – Variable Step Down Regulator Module



HANDLING RECOMMENDATIONS

1. The power module is classified as MSL3 (JEDEC Moisture Sensitivity Level 3) and requires special handling due to moisture sensitivity (JEDEC J-STD033).
2. The parts are delivered in a sealed bag (Moisture Barrier Bags = MBB) and should be processed within one year.
3. When opening the moisture barrier bag check the Humidity Indicator Card (HIC) for color status. Bake parts prior to soldering in case indicator color has changed according to the notes on the card.
4. Parts must be processed after 168 hour (7 days) of floor life. Once this time has been exceeded, bake parts prior to soldering per JEDEC J-STD033 recommendation.

SOLDER PROFILE

1. Only Pb-Free assembly is recommended according to JEDEC J-STD020.
2. Measure the peak reflow temperature of the MagI³C Power Module in the middle of the top view.
3. Ensure that the peak reflow temperature does not exceed 245°C ±5°C as per JEDEC J-STD020.
4. The reflow time period during peak temperature of 245°C ±5°C must not exceed 30 seconds.
5. Reflow time above liquidus (217°C) must not exceed 90 seconds.
6. Maximum ramp up is rate 3°C per second.
7. Maximum ramp down rate is 3°C per second.
8. Reflow time from room (25°C) to peak must not exceed 8 minutes as per JEDEC J-STD020.
9. **Maximum numbers of reflow cycles is three.**
10. **For minimum risk, solder the module in the last reflow cycle of the PCB production.**
11. For soldering process please consider lead material copper (Cu) and lead finish tin (Sn).
12. For solder paste use a standard SAC Alloy such as SAC 305, type 3 or higher.
13. Below profile is valid for convection reflow only.
14. Other soldering methods (e.g.vapor phase) are not verified and have to be validated by the customer on his own risk.

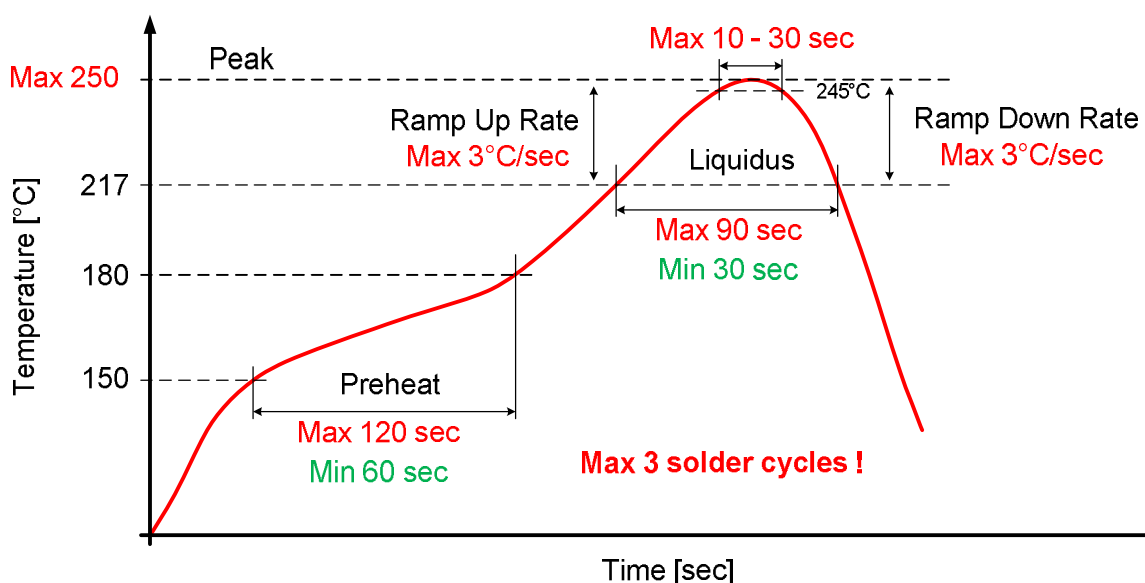

WPMDB1600362Q / 171060302

MagI³C Power Module
VDRM – Variable Step Down Regulator Module



PHYSICAL DIMENSIONS

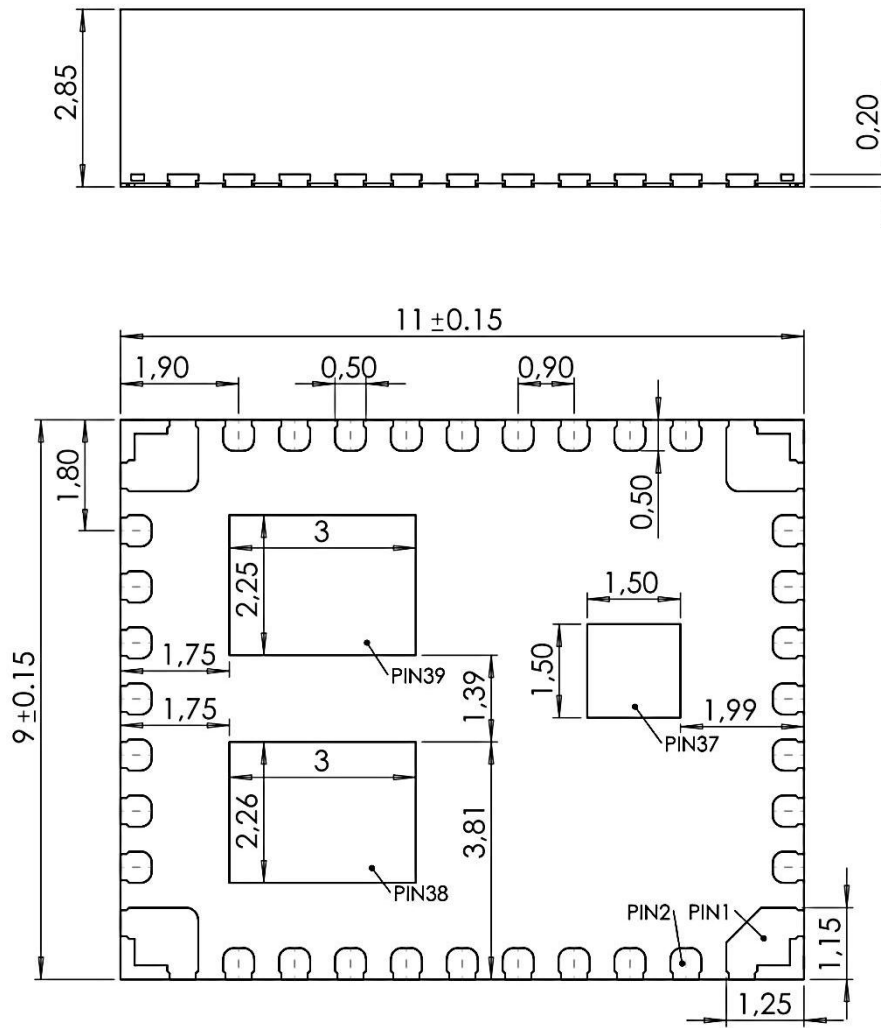

Bottom View

all dimensions in mm

WPMDB1600362Q / 171060302

MagI³C Power Module
VDRM – Variable Step Down Regulator Module



EXAMPLE FOOTPRINT DESIGN

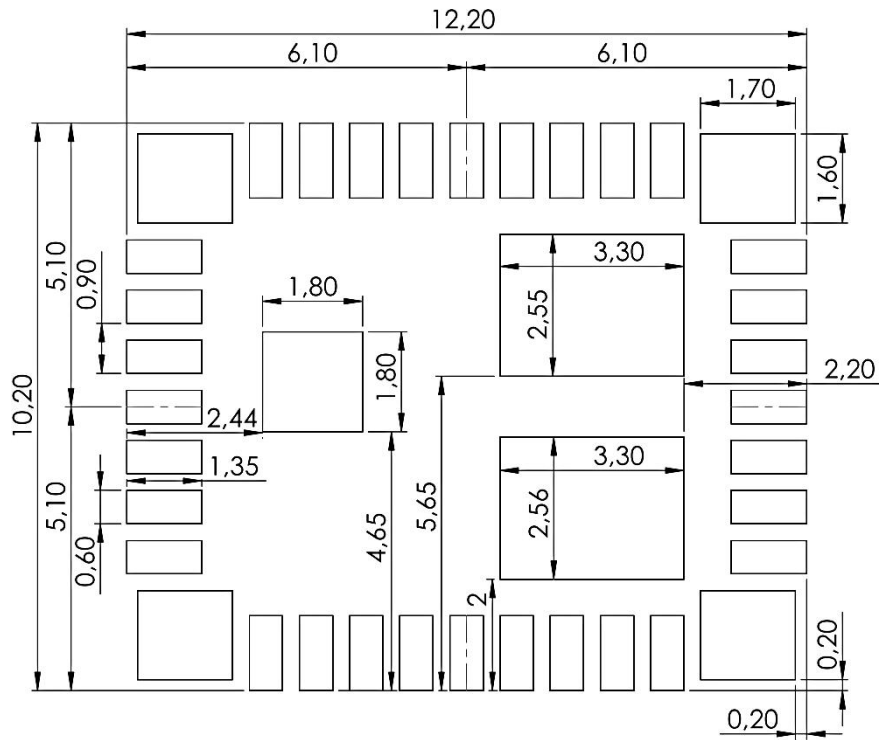

All dimensions in mm

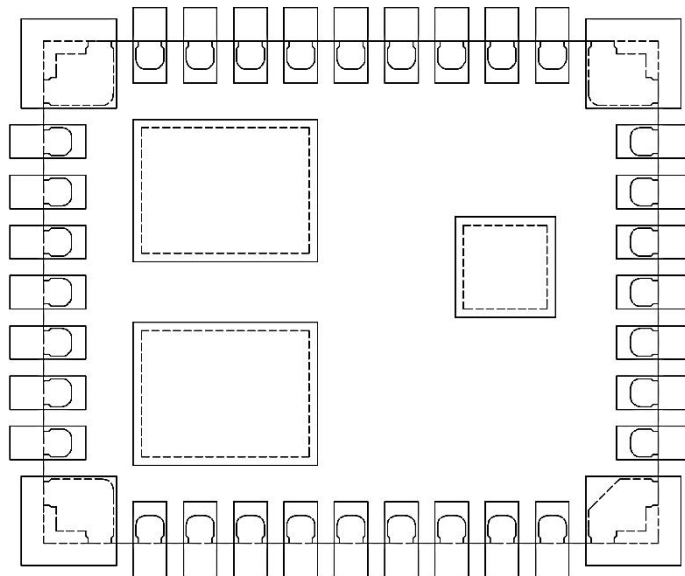

Example footprint with pins

WPMDB1600362Q / 171060302

MagI³C Power Module
 VDRM – Variable Step Down Regulator Module



EXAMPLE SOLDER PASTE STENCIL DESIGN

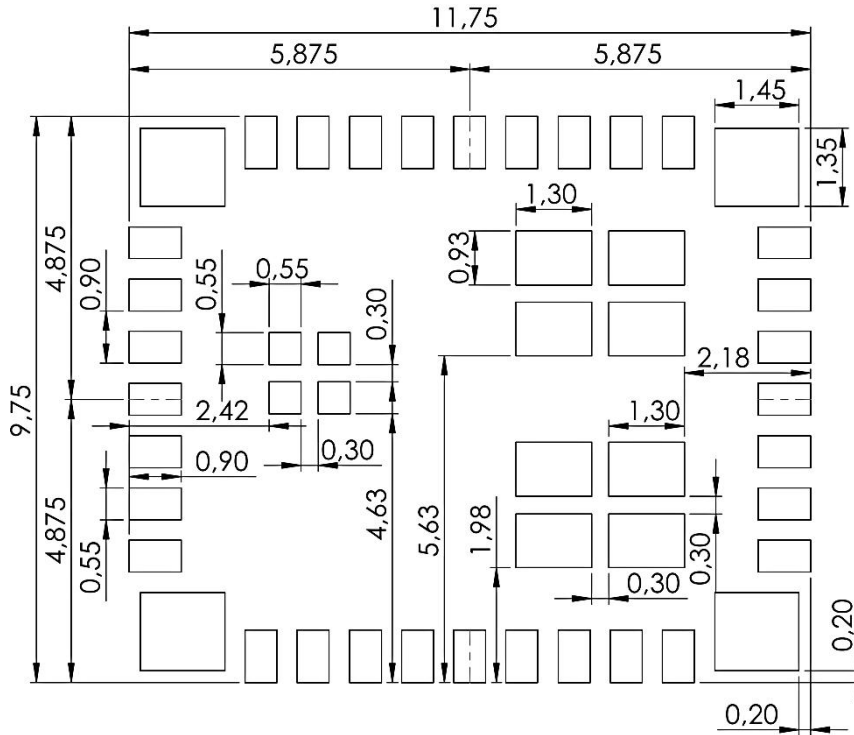

All dimensions in mm

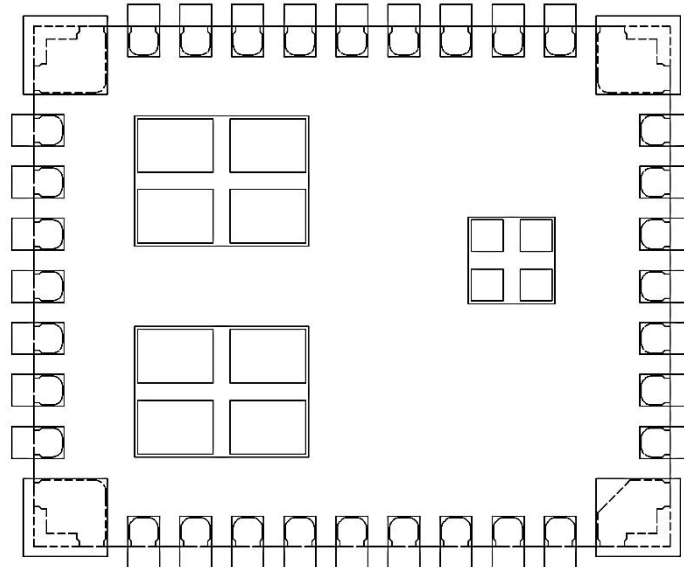

Example solder paste stencil with pins
 Stencil thickness 0.125mm

WPMDB1600362Q / 171060302

MagI³C Power Module
VDRM – Variable Step Down Regulator Module



DOCUMENT HISTORY

Revision	Date	Description	Comment
1.0	May 2016	Release of the final version	

CAUTIONS AND WARNINGS

The following conditions apply to all goods within the product series of MagI³C of Würth Elektronik eiSos GmbH & Co. KG:

General:

All recommendations according to the general technical specifications of the data-sheet have to be complied with.

The usage and operation of the product within ambient conditions which probably alloy or harm the component surface has to be avoided.

The responsibility for the applicability of customer specific products and use in a particular customer design is always within the authority of the customer. All technical specifications for standard products do also apply for customer specific products.

Residual washing varnish agent that is used during the production to clean the application might change the characteristics of the body, pins or termination. The washing varnish agent could have a negative effect on the long term function of the product.

Direct mechanical impact to the product shall be prevented as the material of the body, pins or termination could flake or in the worst case it could break. As these devices are sensitive to electrostatic discharge customer shall follow proper IC Handling Procedures.

Customer acknowledges and agrees that it is solely responsible for compliance with all legal, regulatory and safety-related requirements concerning its products, and any use of Würth Elektronik eiSos GmbH & Co. KG components in its applications, notwithstanding any applications-related information or support that may be provided by Würth Elektronik eiSos GmbH & Co. KG. Customer represents and agrees that it has all the necessary expertise to create and implement safeguards which anticipate dangerous consequences of failures, monitor failures and their consequences lessen the likelihood of failures that might cause harm and take appropriate remedial actions. Customer will fully indemnify Würth Elektronik eiSos and its representatives against any damages arising out of the use of any Würth Elektronik eiSos GmbH & Co. KG components in safety-critical applications.

Product specific:

Follow all instructions mentioned in the datasheet, especially:

- The solder profile has to comply with the technical reflow or wave soldering specification, otherwise this will void the warranty.
- All products are supposed to be used before the end of the period of 12 months based on the product date-code.
- Violation of the technical product specifications such as exceeding the absolute maximum ratings will void the warranty.
- It is also recommended to return the body to the original moisture proof bag and reseal the moisture proof bag again.
- ESD prevention methods need to be followed for manual handling and processing by machinery.

WPMDB1600362Q / 171060302

Magl³C Power Module
VDRM – Variable Step Down Regulator Module



IMPORTANT NOTES

The following conditions apply to all goods within the product range of Würth Elektronik eiSos GmbH & Co. KG:

1. General Customer Responsibility

Some goods within the product range of Würth Elektronik eiSos GmbH & Co. KG contain statements regarding general suitability for certain application areas. These statements about suitability are based on our knowledge and experience of typical requirements concerning the areas, serve as general guidance and cannot be estimated as binding statements about the suitability for a customer application. The responsibility for the applicability and use in a particular customer design is always solely within the authority of the customer. Due to this fact it is up to the customer to evaluate, where appropriate to investigate and decide whether the device with the specific product characteristics described in the product specification is valid and suitable for the respective customer application or not. Accordingly, the customer is cautioned to verify that the datasheet is current before placing orders.

2. Customer Responsibility related to Specific, in particular Safety-Relevant Applications

It has to be clearly pointed out that the possibility of a malfunction of electronic components or failure before the end of the usual lifetime cannot be completely eliminated in the current state of the art, even if the products are operated within the range of the specifications. In certain customer applications requiring a very high level of safety and especially in customer applications in which the malfunction or failure of an electronic component could endanger human life or health it must be ensured by most advanced technological aid of suitable design of the customer application that no injury or damage is caused to third parties in the event of malfunction or failure of an electronic component.

3. Best Care and Attention

Any product-specific notes, warnings and cautions must be strictly observed.

4. Customer Support for Product Specifications

Some products within the product range may contain substances which are subject to restrictions in certain jurisdictions in order to serve specific technical requirements. Necessary information is available on request. In this case the field sales engineer or the internal sales person in charge should be contacted who will be happy to support in this matter.

5. Product R&D

Due to constant product improvement product specifications may change from time to time. As a standard reporting procedure of the Product Change Notification (PCN) according to the JEDEC-Standard we inform about minor and major changes. In case of further queries regarding the PCN, the field sales engineer or the internal sales person in charge should be contacted. The basic responsibility of the customer as per Section 1 and 2 remains unaffected.

6. Product Life Cycle

Due to technical progress and economical evaluation we also reserve the right to discontinue production and delivery of products. As a standard reporting procedure of the Product Termination Notification (PTN) according to the JEDEC-Standard we will inform at an early stage about inevitable product discontinuance. According to this we cannot guarantee that all products within our product range will always be available. Therefore it needs to be verified with the field sales engineer or the internal sales person in charge about the current product availability expectancy before or when the product for application design-in disposal is considered. The approach named above does not apply in the case of individual agreements deviating from the foregoing for customer-specific products.

7. Property Rights

All the rights for contractual products produced by Würth Elektronik eiSos GmbH & Co. KG on the basis of ideas, development contracts as well as models or templates that are subject to copyright, patent or commercial protection supplied to the customer will remain with Würth Elektronik eiSos GmbH & Co. KG. Würth Elektronik eiSos GmbH & Co. KG does not warrant or represent that any license, either expressed or implied, is granted under any patent right, copyright, mask work right, or other intellectual property right relating to any combination, application, or process in which Würth Elektronik eiSos GmbH & Co. KG components or services are used.

8. General Terms and Conditions

Unless otherwise agreed in individual contracts, all orders are subject to the current version of the "General Terms and Conditions of Würth Elektronik eiSos Group", last version available at www.we-online.com.

Данный компонент на территории Российской Федерации

Вы можете приобрести в компании MosChip.

Для оперативного оформления запроса Вам необходимо перейти по данной ссылке:

<http://moschip.ru/get-element>

Вы можете разместить у нас заказ для любого Вашего проекта, будь то серийное производство или разработка единичного прибора.

В нашем ассортименте представлены ведущие мировые производители активных и пассивных электронных компонентов.

Нашей специализацией является поставка электронной компонентной базы двойного назначения, продукции таких производителей как XILINX, Intel (ex.ALTERA), Vicor, Microchip, Texas Instruments, Analog Devices, Mini-Circuits, Amphenol, Glenair.

Сотрудничество с глобальными дистрибьюторами электронных компонентов, предоставляет возможность заказывать и получать с международных складов практически любой перечень компонентов в оптимальные для Вас сроки.

На всех этапах разработки и производства наши партнеры могут получить квалифицированную поддержку опытных инженеров.

Система менеджмента качества компании отвечает требованиям в соответствии с ГОСТ Р ИСО 9001, ГОСТ РВ 0015-002 и ЭС РД 009

Офис по работе с юридическими лицами:

105318, г.Москва, ул.Щербаковская д.3, офис 1107, 1118, ДЦ «Щербаковский»

Телефон: +7 495 668-12-70 (многоканальный)

Факс: +7 495 668-12-70 (доб.304)

E-mail: info@moschip.ru

Skype отдела продаж:

moschip.ru

moschip.ru_4

moschip.ru_6

moschip.ru_9