

FEATURES

- **Functionality**
 - Low speed to high speed SPI exchange device
 - Logical port (LP) mapping (SPI-3 <-> SPI-4) tables per direction
 - Per LP configurable memory allocation
 - Maskable interrupts for fatal errors
 - Fragment and burst length configurable per interface: min 16 bytes, max 256 bytes
- **Standard Interfaces**
 - Two OIF SPI-3: 8 or 32 bit, 19.44-133 MHz, 256 address range, 64 concurrently active LPs per interface
 - One OIF SPI-4 phase 2: 80 - 400 MHz, 256 address range, 128 concurrently active LPs
 - SPI-4 FIFO status channel options:
 - LVDS full-rate
 - LVTTTL eighth-rate
 - Compatible with Network Processor Streaming Interface (NPSI) NPE-Framer mode of operation
 - SPI-4 ingress LVDS automatic bit alignment and lane de-skew over the entire frequency range
 - SPI-4 egress LVDS programmable lane pre-skew 0.1 to 0.3 cycle
 - IEEE 1149.1 JTAG
 - Serial or parallel microprocessor interface for control and monitoring
- **Full Suite of Performance Monitoring Counters**
 - Number of packets
 - Number of fragments

- Number of errors
- Number of bytes

- Green parts available, see ordering information

APPLICATIONS

- Ethernet transport
- SONET / SDH packet transport line cards
- Broadband aggregation
- Multi-service switches
- IP services equipment

DESCRIPTION

The IDT88P8342 is a SPI (System Packet Interface) Exchange with two SPI-3 interfaces and one SPI-4 interface. The data that enter on the low speed interface (SPI-3) are mapped to logical identifiers (LIDs) and enqueued for transmission over the high speed interface (SPI-4). The data that enter on the high speed interface (SPI-4) are mapped to logical identifiers (LIDs) and enqueued for transmission over a low speed interface (SPI-3). A data flow between SPI-3 and SPI-4 interfaces is accomplished with LID maps. The logical port addresses and number of entries in the LID maps may be dynamically configured. Various parameters of a data flow may be configured by the user such as buffer memory size and watermarks. In a typical application, the IDT88P8342 enables connection of two SPI-3 devices to a SPI-4 network processor. In other applications a SPI-3 or SPI-4 device may be connected to a SPI-3 network processor or traffic manager.

FUNCTIONAL BLOCK DIAGRAM

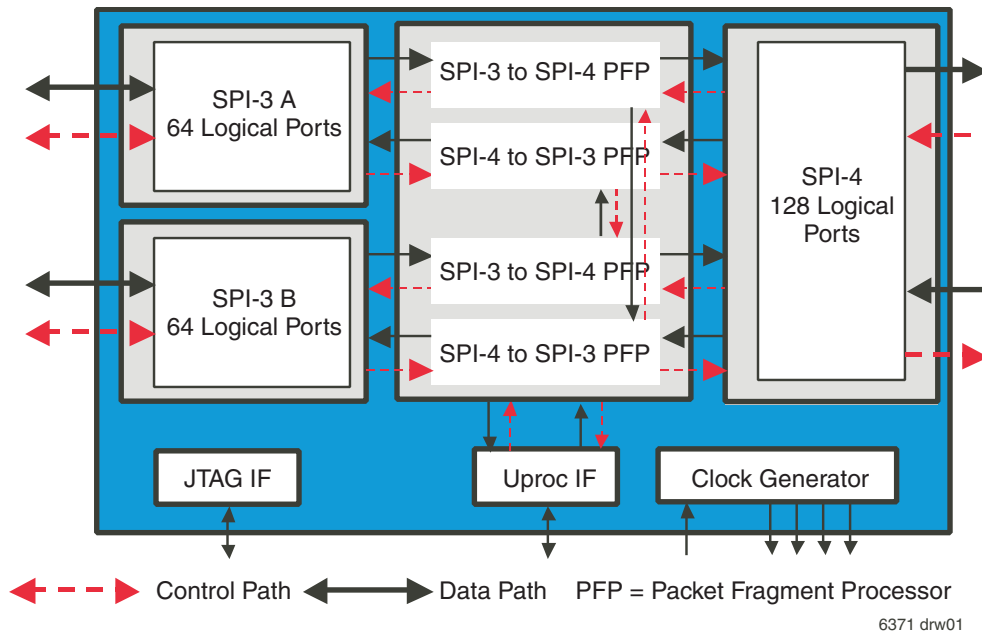

Table of Contents

Features	1
Applications	1
1. Introduction	8
2. Pin description	9
3. External interfaces	13
3.1 SPI-3	13
3.1.1 SPI-3 ingress	13
3.1.2 SPI-3 egress	15
3.2 SPI-4	17
3.2.1 SPI-4 ingress	17
3.2.2 SPI-4 egress	20
3.2.3 SPI-4 startup handshake	20
3.3 Microprocessor interface	22
4. Datapath and flow control	23
4.1 SPI-3 to SPI-4 datapath and flow control	25
4.2 SPI-4 to SPI-3 datapath and flow control	30
4.3 SPI-3 ingress to SPI-3 egress datapath	33
4.4 Microprocessor interface to SPI-3 datapath	34
4.4.1 SPI-3 to ingress microprocessor interface datapath	34
4.4.2 Microprocessor insert to SPI-3 egress datapath	35
4.4.3 Microprocessor interface to SPI-4 egress datapath	36
4.4.4 SPI-4 ingress to microprocessor interface datapath	37
5. Performance monitor and diagnostics	38
5.1 Mode of operation	38
5.2 Counters	38
5.2.1 LID associated event counters	38
5.2.2 Non - LID associated event counters	38
5.3 Captured events	38
5.3.1 Non LID associated events	38
5.3.2 LID associated events	38
5.3.2.1 Non critical events	38
5.3.2.2 Critical events	38
5.3.3 Timebase	38
5.3.3.1 Internally generated timebase	38
5.3.3.2 Externally generated timebase	38
6. Clock generator	39
7. Loopbacks	40
7.1 SPI-3 Loopback	40
8. Operation guide	41
8.1 Hardware operation	41
8.1.1 System reset	41
8.1.2 Power on sequence	41
8.1.3 Clock domains	41
8.2 Software operation	41
8.2.1 Chip configuration sequence	41
8.2.2 Logical Port activation and deactivation	42
8.2.3 Buffer segment modification	42
8.2.4 Manual SPI-4 ingress LVDS bit alignment	42
8.2.5 SPI-4 status channel software	43
8.2.6 IDT88P8342 layout guidelines	43
8.2.7 Software Eye-Opening Check on SPI-4 Interface	44
9. Register description	46
9.1 Register access summary	46
9.1.1 Direct register format	46
9.1.2 Indirect register format	46
9.2 Direct access registers	50

Table of Contents (Continued)

9.3 Indirect registers for SPI-3A and SPI-3B modules	56
9.3.1 Block base 0x0000 registers	57
9.3.2 Block base 0x0200 registers	57
9.3.3 Block base 0x0500 registers	58
9.3.4 Block base 0x0700 registers	59
9.3.5 Block base 0x0A00 registers	61
9.3.6 Block base 0x0C00 registers	61
9.3.7 Block base 0x0100 registers	64
9.3.8 Block base 0x1100 registers	64
9.3.9 Block base 0x1200 registers	64
9.3.10 Block base 0x1300 registers	65
9.3.11 Block base 0x1600 registers	66
9.3.12 Block base 0x1700 registers	66
9.3.13 Block base 0x1800 registers	66
9.3.14 Block base 0x1900 registers	67
9.4 Common module indirect registers (Module_base 0x8000)	68
9.4.1 Common module block base 0x0000 registers	69
9.4.2 Common module block base 0x0100 registers	69
9.4.3 Common module block base 0x0200 registers	69
9.4.4 Common module block base 0x0300 registers	69
9.4.5 Common module block base 0x0400 registers	72
9.4.6 Common module block base 0x0500 registers	72
9.4.7 Common module block base 0x0600 registers	73
9.4.8 Common module block base 0x0700 registers	73
9.4.9 Common module block base 0x0800 registers	75
10. JTAG interface	79
11. Electrical and Thermal Specifications	79
11.1 Absolute maximum ratings	79
11.2 Recommended Operating Conditions	79
11.3 Terminal Capacitance	80
11.4 Thermal Characteristics	80
11.5 DC Electrical characteristics	81
11.6 AC characteristics	82
11.6.1 SPI-3 I/O timing	82
11.6.2 SPI-4 LVDS Input / Output	83
11.6.3 SPI-4 LVTTTL Status AC characteristics	84
11.6.4 REF_CLK clock input	84
11.6.5 MCLK internal clock and OCLK[3:0] clock outputs	84
11.6.6 Microprocessor interface	84
11.6.6.1 Microprocessor parallel port AC timing specifications	85
11.6.6.2 Serial microprocessor interface (serial peripheral interface mode)	89
12. Mechanical characteristics	90
12.1 Device overview	90
12.2 Pin name/ball location table	91
12.3 Device package	94
13. Glossary	96
14. Datasheet Document Revision History	97
15. Ordering information	98

List of Figures

Figure 1. Typical application: optical port and two NPUs	8
Figure 2. Data Path Diagram	8
Figure 3. Link mode SPI-3 ingress interface	14
Figure 4. PHY mode SPI-3 ingress interface	14
Figure 5. Link mode SPI-3 egress interface	16
Figure 6. PHY mode SPI-3 egress interface	16
Figure 7. Data sampling diagram	18
Figure 8. SPI-4 ingress state diagram	19
Figure 9. SPI-4 egress status state diagram	21
Figure 10. Interrupt scheme	22
Figure 11. Definition of data flows	23
Figure 12. Logical view of datapath configuration using PFPs	24
Figure 13. SPI-3 ingress to SPI-4 egress packet fragment processor	25
Figure 14. SPI-3 ingress LP to LID map	27
Figure 15. SPI-4 egress LID to LP map	28
Figure 16. SPI-3 ingress to SPI-4 egress datapath	28
Figure 17. SPI-3 ingress to SPI-4 egress flow control path	29
Figure 18. SPI-4 ingress to SPI-3 egress packet fragment processor	30
Figure 19. SPI-4 ingress to SPI-3 egress datapath	31
Figure 20. SPI-4 ingress to SPI-3 egress flow control	32
Figure 21. SPI-3 ingress to SPI-3 egress datapath	33
Figure 22. Microprocessor data capture buffer	34
Figure 23. SPI-3 ingress to microprocessor capture interface datapath	34
Figure 24. Microprocessor data insert buffer	35
Figure 25. Microprocessor interface to SPI-3 egress detailed datapath diagram	35
Figure 26. Microprocessor data insert buffer	36
Figure 27. Microprocessor data insert interface to SPI-4 egress datapath	36
Figure 28. Microprocessor data capture buffer	37
Figure 29. SPI-4 ingress to microprocessor data capture interface path	37
Figure 30. Clock generator	39
Figure 31. SPI-3 Loopback diagram	40
Figure 32. Power-on-Reset Sequence	41
Figure 33. DDR interface and eye opening check through over sampling	44
Figure 34. Direct & indirect access	46
Figure 35. SPI-3 I/O timing diagram	82
Figure 36. SPI-4 I/O timing diagram	83
Figure 37. Microprocessor parallel port Motorola read timing diagram	85
Figure 38. Microprocessor parallel port Motorola write timing diagram	86
Figure 39. Microprocessor parallel port Intel mode read timing diagram	87
Figure 40. Microprocessor parallel port Intel mode write timing diagram	88
Figure 41. Microprocessor serial peripheral interface timing diagram	89
Figure 42. IDT88P8342 820PBGA package, bottom view	94
Figure 43. IDT88P8342 820PBGA package, top and side views	95

List of Tables

Table 1 – I/O types	9
Table 2 – SPI-3 ingress interface pin definition	9
Table 3 – SPI-3 egress interface pin definition	10
Table 4 – SPI-3 status interface pin definition	10
Table 5 – SPI-4 ingress interface definition	11
Table 6 – SPI-4 egress interface definition	11
Table 7 – Parallel microprocessor interface	12
Table 8 – Serial microprocessor interface (serial peripheral interface mode)	12
Table 9 – Miscellaneous	12
Table 10 – Both attached devices start from reset status	20
Table 11 – Ingress out of synch, egress in synch	20
Table 12 – Ingress in synch, egress out of synch	20
Table 13 - DIRECTION code assignment	26
Table 14 – CK_SEL[3:0] input pin encoding	39
Table 15 - Zero margin SPI-3 timing budget	43
Table 16 - Margin check for SPI-3 timing	43
Table 17 - Bit order within an 8-Bit data register	46
Table 18 - Bit order within a 32-Bit data register	46
Table 19 - Bit order within an 8-Bit data register	46
Table 20 - Bit order within a 16-Bit address register	47
Table 21 - Bit order within an 8-Bit control register	47
Table 22 - Module base address (Module_base)	47
Table 23 - Indirect access block bases for Module A and Module B	47
Table 24 - Indirect access block bases for common module	48
Table 25 - Indirect access data registers (direct accessed space) at 0x30 to 0x33	48
Table 26 - Indirect access address register (direct accessed space) at 0x34 to 0x35	48
Table 27 - Indirect access control register (direct accessed space) at 0x3F	48
Table 28 - Error coding table	49
Table 29 - Direct mapped Module A and Module B registers	50
Table 30 - Direct mapped other registers	50
Table 31 - SPI-3 data capture control register (registers 0x00 and 0x08)	50
Table 32 - SPI-3 data capture register (registers 0x01 and 0x09)	50
Table 33 - SPI-4 data insert control register (registers 0x02 and 0x0A)	51
Table 34 - SPI-4 data insert register (registers 0x03 and 0x0B)	51
Table 35 - SPI-4 data capture control registers (registers 0x04 and 0x0C)	51
Table 36 - SPI-3 data insert control register (registers 0x05 and 0x0D)	51
Table 37 - SPI-4 data capture register (registers 0x06 and 0x0E)	51
Table 38 - SPI-3 data insert register (registers 0x07 and 0x0F)	51
Table 39 - Software reset register (0x20 in the direct accessed space)	52
Table 40 - SPI-4 status register (0x22 in the direct accessed space)	52
Table 41 - SPI-4 enable register (0x23 in the direct accessed space)	52
Table 42 - Module status register (0x24 and 0x25 in the direct accessed space)	53
Table 43 - Module enable register (0x28 and 0x29 in the direct accessed space)	53
Table 44 - Primary interrupt status register (0x2C in the direct accessed space)	54
Table 45 - Secondary interrupt status register (0x2D in the direct accessed space)	54
Table 46 - Primary interrupt enable register (0x2E in the direct accessed space)	55
Table 47 - Secondary interrupt enable register (0x2F in the direct accessed space)	55
Table 48 - Module A/B indirect register	56
Table 49 - SPI-3 ingress LP to LID map	57
Table 50 - SPI-3 general configuration register (register_offset=0x00)	57
Table 51 - SPI-3 ingress configuration register (register_offset=0x01)	58
Table 52 - SPI-3 ingress fill level register (register_offset=0x02)	58
Table 53 - SPI-3 ingress max fill level register (register_offset=0x03)	58
Table 54 - SPI-3 egress LID to LP map	58
Table 55 - SPI-3 egress configuration register (register_offset=0x00)	59
Table 56 - SPI-4 ingress to SPI-3 egress flow control register (register_offset=0x01)	59

List of Tables (Continued)

Table 57 - SPI-3 egress test register (register_offset=0x02)	59
Table 58 - SPI-3 egress fill level register (register_offset=0x03)	60
Table 59 - SPI-3 egress max fill level register (register_offset=0x04)	60
Table 60 - LID associated event counters (0x000-0x17F)	61
Table 61 - Non LID associated event counters (0x00 - 0x0B)	61
Table 62 - Non LID associated interrupt indication register (register_offset 0x0c)	62
Table 63 - Non LID associated interrupt enable register(register_offset 0x0D)	62
Table 64 - LID associated interrupt indication register (register_offset 0x0E)	62
Table 65 - LID associated interrupt enable register (register_offset 0x0F)	62
Table 66 - Non critical LID associated capture table (register_offset 0x10-0x15)	63
Table 67 - SPI-3 to SPI-4 critical LID interrupt indication registers (register_offset 0x16-0x17)	63
Table 68 - SPI-3 to SPI-4 critical LID interrupt enable registers (register_offset 0x18-0x19)	63
Table 69 - SPI-4 to SPI-3 critical LID interrupt indication registers (register_offset 0x1A-0x1B)	63
Table 70 - SPI-4 to SPI-3 critical LID interrupt enable registers (register_offset 0x1C-0x1D)	63
Table 71 - Critical events source indication register (register_offset 0x1E)	63
Table 72 - SPI-3 ingress packet length configuration register	64
Table 73 - SPI-4 egress port descriptor table (64 entries)	64
Table 74 - SPI-4 egress DIRECTION code assignment	64
Table 75 - SPI-3 ingress port descriptor table (Block_base 0x1200)	64
Table 76 - SPI-3 to SPI-4 PFP register (register_offset 0x00)	65
Table 77 - NR_LID field encoding	65
Table 78 - SPI-3 to SPI-4 flow control register (register_offset 0x01)	65
Table 79 - SPI-4 ingress packet length configuration (64 entries configurable)	66
Table 80 - SPI-3 egress port descriptor table (64 entries)	66
Table 81 - SPI-3 egress DIRECTION code assignment	66
Table 82 - SPI-4 ingress port descriptor tables (64 entries)	66
Table 83 - SPI-4 to SPI-3 PFP register (0x00)	67
Table 84 - NR_LID field encoding	67
Table 85 -Common Module (Module_base 0x8000) indirect register table	68
Table 86 - SPI-4 ingress LP to LID map (256 entries, one per LP)	69
Table 87 - SPI-4 ingress calendar_0 (256 entries)	69
Table 88 - SPI-4 ingress calendar_1 (256 entries)	69
Table 89 - SPI-4 ingress configuration register (0x00)	69
Table 90 - SPI-4 ingress status configuration register (register_offset 0x01)	70
Table 91 - SPI-4 ingress status register (register_offset 0x02)	70
Table 92 - SPI-4 ingress inactive transfer port (register_offset 0x03)	70
Table 93 - SPI-4 ingress calendar configuration register (0x04 to 0x05)	71
Table 94 - SPI-4 ingress watermark register (register_offset 0x06)	71
Table 95 - SPI-4 ingress fill level register (0x07 to 0x08)	71
Table 96 - SPI-4 ingress max fill level register (0x0B and 0x0C)	71
Table 97 - SPI-4 ingress diagnostics register (register_offset 0x0F)	71
Table 98 - SPI-4 ingress DIP-4 error counter (register_offset 0x10)	72
Table 99 - SPI-4 ingress bit alignment control register (register_offset 0x11)	72
Table 100 - SPI-4 ingress start up training threshold register (register_offset 0x12)	72
Table 101 - SPI-4 egress LID to LP map (128 entries)	72
Table 102 - SPI-4 egress calendar_0 (256 locations)	72
Table 103 - SPI-4 egress calendar_1 (256 locations)	73
Table 104 - SPI-4 egress configuration register_0 (register_offset 0x00)	73
Table 105 - SPI-4 egress configuration register_1 (register_offset 0x01)	73
Table 106 - SPI-4 egress status register (register_offset 0x02)	74
Table 107 - SPI-4 egress calendar configuration register (Register_offset 0x03 - 0x04)	74
Table 108 - SPI-4 egress diagnostics register (register_offset 0x05)	74
Table 109 - SPI-4 egress DIP-2 error counter (register_offset 0x06)	74
Table 110 - SPI-4 ingress bit alignment window register (register_offset 0x00)	75
Table 111 - SPI-4 ingress lane measure register (register_offset 0x01)	75

List of Tables (Continued)

Table 112 - SPI-4 ingress bit alignment counter register (0x02 to 0x0B)	75
Table 113 - SPI-4 ingress manual alignment phase/result register (0x0C to 0x1F)	75
Table 114 - SPI-4 egress data lane timing register (register_offset 0x2A)	75
Table 115 - SPI-4 egress Control Lane Timing register (Register_offset 0x2B)	76
Table 116 - SPI-4 egress data clock timing register (register_offset 0x2C)	76
Table 117 - SPI-4 egress status timing register (register_offset 0x2D)	76
Table 118 - SPI-4 egress status clock timing register (register_offset 0x2E)	76
Table 119 - PMON timebase control register (register_offset 0x00)	77
Table 120 - Timebase register (register_offset 0x01)	77
Table 121 - Clock generator control register (register_offset 0x10)	77
Table 122 - OCLK and MCLK frequency select encoding	77
Table 123 - GPIO register (register_offset 0x20)	78
Table 124 - GPIO monitor table (5 entries 0x21-0x25 for GPIO[0] through GPIO[4])	78
Table 125 - Version number register (register_offset 0x30)	78
Table 126 - JTAG instructions	79
Table 127 - Absolute maximum ratings	79
Table 128 - Recommended Operating Conditions	79
Table 129 - Terminal Capacitance	80
Table 130 - Thermal Characteristics	80
Table 131 - DC Electrical characteristics	81
Table 132 - SPI-3 AC Input / Output timing specifications	82
Table 133 - SPI-4.2 LVDS AC Input / Output timing specifications	84
Table 134 - SPI-4 LVTTTL status AC Characteristics	84
Table 135 - REF_CLK clock input	84
Table 136 - OCLK[3:0] clock outputs and MCLK internal clock	84
Table 137 - Microprocessor interface	84
Table 138 - Microprocessor parallel port Motorola read timing	85
Table 139 - Microprocessor parallel port Motorola write timing	86
Table 140 - Microprocessor parallel port Intel mode read timing	87
Table 141 - Microprocessor parallel port Intel mode write timing	88
Table 142 - Microprocessor serial peripheral interface timing	89

TYPICAL APPLICATION

Exchange between optical ports and two NPU/Traffic Managers

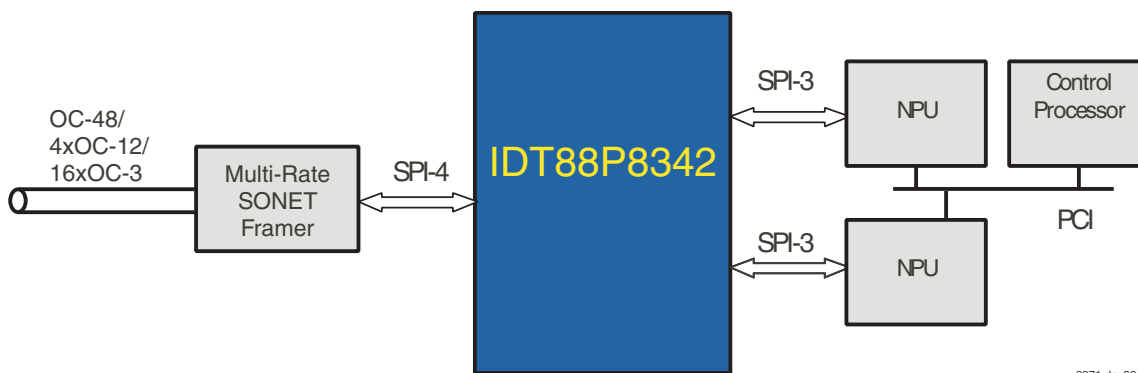

6371 drw02

Figure 1. Typical application: optical port and two NPUs

1. INTRODUCTION

The IDT88P8342 device is a dual SPI-3 to single SPI-4 exchange intended for use in optical line cards, Ethernet transport, and multi-service switches. The SPI-3 and SPI-4 interfaces are defined by the Optical Interworking Forum.

The device can be used as a rate adapter, a switch, or an aggregation device between network processor units, multi-gigabit framers and PHYs, and switch fabric interface devices.

DATA PATH OVERVIEW

Figure 1. Data Path Diagram shows an overview of the data path through the device.

In normal operation, there are two paths through the IDT88P8342 device: the dual SPI-3 ingress to SPI-4 egress path, and the SPI-4 ingress to dual SPI-3 egress path. SPI-3 and SPI-4 burst sizes are separately configurable.

In the SPI-3 ingress to SPI-4 egress path, data enter in fragments on the SPI-3 interface and are received by the SPI-3 interface block. The fragments are mapped to a SPI-4 address and stored in memory allocated at the SPI-3 level until such a time that the Packet Fragment Processor determines that they are to be transmitted on the SPI-4 interface. The data is transferred in bursts, in line with the OIF SPI-4 implementation agreement, to the SPI-4 interface block, and are transmitted on the SPI-4 interface.

In the SPI-4 ingress to SPI-3 egress path, data enter in bursts on the SPI-4 interface and are received by the SPI-4 interface block. The SPI-4 address is translated to a SPI-3 address, and the data contained in the bursts are stored in memory allocated at the SPI-3 level until such a time that the Packet Fragment Processor determines that they are to be transmitted on the SPI-3 interface. The data is transferred in packet fragments, in line with the OIF SPI-3 implementation agreement, to the SPI-3 interface block, and are transmitted on the SPI-3 interface.

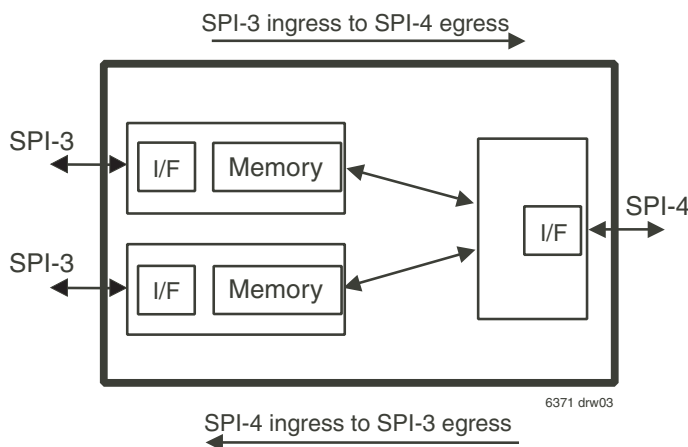

6371 drw03

Figure 2. Data Path Diagram

2. PIN DESCRIPTION

SPI-3 (two instantiations)

For the SPI-3 interfaces, each pin is used differently depending whether the SPI-3 is in Link mode or in PHY mode. Each of the SPI-3 interfaces is separately

configurable for either Link or PHY mode. This configuration holds for both the ingress and egress paths. The device pin is given a generic name, and mapped to the standard pin name according to the mode of the interface (Link or PHY).

TABLE 1 – I/O TYPES

I/O type	Function
I-ST	Input with Schmitt trigger with weak pull up
I-PU	Input with weak pull up
B-PU	Bidirectional I/O with weak pull up
I-PD	Input with pull down
I	Input
O	Output
O-Z	Output with tri-state
OD	Output with open drain

TABLE 2 – SPI-3 INGRESS INTERFACE PIN DEFINITION

Generic Name	Specific Name	I/O type	Description	Mode	
				Link	PHY
I_FCLK	SPI3A_I_FCLK SPI3B_I_FCLK	I-ST LVTTTL	Ingress SPI-3 write clock	RFCLK	TFCLK
RVAL	SPI3A_I_RVAL SPI3B_I_RVAL	B-PU LVTTTL	Receive data valid	RVAL (I)	RVAL (O)
I_ENB	SPI3A_I_ENB SPI3B_I_ENB	B-PU LVTTTL	Ingress read enable	RENB (O)	TENB (I)
I_DAT[31:0]	SPI3A_I_DAT[31:0] SPI3B_I_DAT[31:0]	I-PU LVTTTL	Ingress data bus	RDAT [31:0]	TDAT [31:0]
I_MOD[1:0]	SPI3A_I_MOD[1:0] SPI3B_I_MOD[1:0]	I-PU LVTTTL	Ingress word modulus	RMOD [1:0]	TMOD [1:0]
I_PRTY	SPI3A_I_PRTY SPI3B_I_PRTY	I-PU LVTTTL	Ingress parity	RPRTY	TPRTY
I_SOP	SPI3A_I_SOP SPI3B_I_SOP	I-PU LVTTTL	Ingress start of packet	RSOP	TSOP
I_EOP	SPI3A_I_EOP SPI3B_I_EOP	I-PU LVTTTL	Ingress end of packet	REOP	TEOP
I_ERR	SPI3A_I_ERR SPI3B_I_ERR	I-PU LVTTTL	Ingress EOP error	RERR	TERR
I_SX	SPI3A_I_SX SPI3B_I_SX	I-PU LVTTTL	Ingress start of transfer	RSX	TSX

TABLE 3 – SPI-3 EGRESS INTERFACE PIN DEFINITION

Generic Name	Specific Name	I/O type	Description	Mode	
				Link	PHY
E_FCLK	SPI3A_E_FCLK SPI3B_E_FCLK	I-ST LVTTTL	Egress SPI-3 write clock	TFCLK	RFCLK
E_ENB	SPI3A_E_ENB SPI3B_E_ENB	B-PU LVTTTL	Egress read enable	TENB (O)	RENB (I)
E_DAT[31:0]	SPI3A_E_DAT[31:0] SPI3B_E_DAT[31:0]	O-Z LVTTTL	Egress data bus	TDAT [31:0]	RDAT [31:0]
E_MOD[1:0]	SPI3A_E_MOD[1:0] SPI3B_E_MOD[1:0]	O-Z LVTTTL	Egress word modulus	TMOD [1:0]	RMOD [1:0]
E_PRTY	SPI3A_E_PRTY SPI3B_E_PRTY	O-Z LVTTTL	Egress parity	TPRTY	RPRTY
E_SOP	SPI3A_E_SOP SPI3B_E_SOP	O-Z LVTTTL	Egress start of packet	TSOP	RSOP
E_EOP	SPI3A_E_EOP SPI3B_E_EOP	O-Z LVTTTL	Egress end of packet	TEOP	REOP
E_ERR	SPI3A_E_ERR SPI3B_E_ERR	O-Z LVTTTL	Egress EOP error	TERR	RERR
E_SX	SPI3A_E_SX SPI3B_E_SX	O-Z LVTTTL	Egress start of transfer	TSX	RSX

TABLE 4 – SPI-3 STATUS INTERFACE PIN DEFINITION

Generic Name	Specific Name	I/O type	Description	Mode	
				Link	PHY
DTPA[3:0]	SPI3A_DTPA[3:0] SPI3B_DTPA[3:0]	B-PU LVTTTL	Direct transmit packet available	DTPA (I)	DTPA (O)
STPA	SPI3A_STPA SPI3B_STPA	B-PU LVTTTL	Selected-PHY transmit packet available	STPA (I)	STPA (O)
PTPA	SPI3A_PTPA SPI3B_PTPA	B-PU LVTTTL	Polled-PHY transmit packet available	PTPA (I)	PTPA (O)
ADR[7:0]	SPI3A_ADR[7:0] SPI3B_ADR[7:0]	B-PU LVTTTL	Polled transmit PHY address	ADR (O)	ADR (I)

SPI-4 (one instantiation)

For the SPI-4 interface, each pin is used differently depending whether the SPI-4 is in Link mode or in PHY mode. The pin is given a generic name, shown

in the Name column, and mapped to the OIF standard pin name according to the mode of operation of the interface (Link to PHY).

TABLE 5 – SPI-4 INGRESS INTERFACE DEFINITION

Generic Name	Specific Name	I/O type	Description	Mode	
				Link	PHY
I_DCLK (P & N)	SPI4_I_DCLK_P SPI4_I_DCLK_N	I LVDS	Ingress data clock	RDCLK	TDCLK
I_DAT[15:0] (P & N)	SPI4_I_DAT_P[15:0] SPI4_I_DAT_N[15:0]	I LVDS	Ingress data bus	RDAT	TDAT
I_CTRL (P & N)	SPI4_I_CTRL_P SPI4_I_CTRL_N	I LVDS	Ingress control word	RCTL	TCTL
I_SCLK_L (P & N)	SPI4_I_SCLK_P SPI4_I_SCLK_N	O LVDS	Ingress status clock	RSCLK	TSCLK
I_STAT_L[1:0] (P & N)	SPI4_I_STAT_P[1:0] SPI4_I_STAT_N[1:0]	O LVDS	Ingress status info	RSTAT	TSTAT
I_SCLK_T	SPI4_I_SCLK_T	O LVTTTL	Ingress status clock	RSCLK	TSCLK
I_STAT_T[1:0]	SPI4_I_STAT_T[1:0]	O LVTTTL	Ingress status info	RSTAT	TSTAT
BIAS	BIAS	Analog	Use an external 3K Ohm 1% resistor to VSS	-----	-----
LVDS_STA	LVDS_STA	I-PU	LVDS(high)/LVTTTL (low) status selection (See note below)	-----	-----

NOTE:

1. A hardware reset or software reset must be performed after changing the level of this pin.

TABLE 6 – SPI-4 EGRESS INTERFACE DEFINITION

Generic Name	Specific Name	I/O type	Description	Mode	
				Link	PHY
E_DCLK (P & N)	SPI4_E_DCLK_P SPI4_E_DCLK_N	O LVDS	Egress data clock	TDCLK	RDCLK
E_DAT[15:0] (P & N)	SPI4_E_DAT_P[15:0] SPI4_E_DAT_N[15:0]	O LVDS	Egress data bus	TDAT[15:0]	RDAT[15:0]
E_CTRL (P & N)	SPI4_E_CTRL_P SPI4_E_CTRL_N	O LVDS	Egress control word	TCTL	RCTL
E_SCLK_L (P & N)	SPI4_E_SCLK_P SPI4_E_SCLK_N	I LVDS	Egress status clock	TSCLK	RSCLK
E_STAT_L[1:0] (P & N)	SPI4_E_STAT_P[1:0] SPI4_E_STAT_N[1:0]	I LVDS	Egress status info	TSTAT[1:0]	RSTAT[1:0]
E_SCLK_T	SPI4_E_SCLK_T	I-ST LVTTTL	Egress status clock	TSCLK	RSCLK
E_STAT_T[1:0]	SPI4_E_STAT_T[1:0]	I-PU LVTTTL	Egress status info	TSTAT	RSTAT[1:0]

Parallel microprocessor Interface

The Parallel microprocessor interface is configurable to work in Intel or Motorola modes. Be sure to connect SPI_EN to a logic low when using the parallel microprocessor interface mode.

TABLE 7 – PARALLEL MICROPROCESSOR INTERFACE

Name	I/O type	Description
MPM	I-PU CMOS	Microprocessor mode: 0=Motorola Mode, 1=Intel mode (sampled after reset)
CSB	I-ST CMOS	Chip select; active low
RDB	I-ST CMOS	RDB: Read control, active low (in Intel mode), or DSB: Data strobe, active low (in Motorola mode)
WRB	I-ST CMOS	WRB: Write control; active low; (in Intel mode), or R/WB: Read/write control; when high, read is active; when low, write is active; (in Motorola mode)
ADD[5:0]	I-PU CMOS	Address bus
DBUS[7:0]	B-PU CMOS	Data bus
INTB	OD CMOS	Interrupt, active low, open drain
SPI_EN	I-PU CMOS	Logic low selects parallel microprocessor interface (internally pulled up, sampled after reset)

TABLE 8 – SERIAL MICROPROCESSOR INTERFACE (SERIAL PERIPHERAL INTERFACE MODE)

Four Pins Multiplexed with Parallel microprocessor Pins. Be sure to connect SPI_EN to a logic high when using the serial microprocessor interface mode.

Name	I/O type	Parallel microprocessor pin used	Serial Peripheral Interface Pin Use Description
SDI	I-ST CMOS	WRB	Serial data in, rise edge sampling
SDO	B-PU CMOS	DBUS[0]	Serial data out, falling edge driving
CSB	I-ST CMOS	CSB	Chip select, active low. SDO is tri-stated when CSB is high
SCLK	I-ST CMOS	RDB	Input clock
INTB	OD CMOS	-----	Interrupt, active low, open drain
SPI_EN	I-PU CMOS	-----	Dedicated input. High selects SPI microprocessor interface (internally pulled up)

TABLE 9 – MISCELLANEOUS

Name	I/O type	Description
REF_CLK	I-ST CMOS	Master clock input
OCLK[3:0]	O LVTTTL	Clock outputs that can be used for SPI-3, phase-shifted to avoid simultaneously switching outputs
CLK_SEL[3:0]	I-PU CMOS	Clock select inputs for internal PLL, internal MCLK, and OCLK[3:0] outputs
TIMEBASE	B-PU CMOS	Timeout signal for counters
GPIO[4:0]	B-PU CMOS	General purpose I/O or internal state monitor pins
TDI	I-PU CMOS	JTAG data in (internally pulled up)
TDO	O-Z CMOS	JTAG data out
TCK	I-ST CMOS	JTAG clock
TMS	I-PU CMOS	JTAG mode (internally pulled up)
TRSTB	I-PU CMOS	JTAG reset, active low (internally pulled up). Pull down for normal operation.
RESETB	I-PD CMOS	Master hardware reset, active low

NOTE:

- Inputs with internal pull-ups do not need external pull-ups unless connected to PCB trace (except TRSTB).

3. EXTERNAL INTERFACES

The external interfaces provided on the IDT88P8342 device are two SPI-3 interfaces, one SPI-4 interface, a serial or parallel microprocessor interface, a JTAG interface, and a set of GPIO pins. Each of the interfaces is defined in the relevant standard.

The following information contains a set of the highlights of the features supported from the relevant standards, and a description of additional features implemented to enhance the usability of these interfaces for the system architect.

3.1 SPI-3

Refer to OIF SPI-3 document (see 13. Glossary for a reference) for full details of the implementation agreement.

- Two instantiations of SPI-3 interface; each interface independently configurable
- Device supports a 8-bit and 32-bit data bus structure.
- Clock rate is minimum 19.44 to maximum 133 MHz
- Link, single port PHY, and single device multi port PHY modes supported
- Byte level and packet level transfer control mechanisms supported
 - Four DTPA signals supported, mapped to LP addresses 0–3, for STPA in byte-level mode
 - Eight ADR signals supported for PTPA in packet-level mode
- Address range 0 to 255 with support for 64 simultaneously active logical ports
- Fragment length (section) configurable from 16 to 256 bytes in 16 byte multiples
- Configurable standard and non-standard bit ordering

SPI-3 implementation features

The following are implemented per SPI-3 interface, and there are two instantiations per device.

- Link / PHY layer device
- Packet / byte level FIFO status information
- Physical port enable
- Width of data bus (32 bit or 8 bit)
- Parity selection (odd or even)
- Enable parity check

3.1.1 SPI-3 ingress

The following are implemented per SPI-3 interface, and there are 4 instantiations per device.

- SPI-3 LP to Link Identifier (LID) map
- 256 entries, one per SPI-3 LP address
- LP enable control
- Only 64 of these entries are to be in the active state simultaneously

Backpressure enable

- Link mode only
- Enables the assertion of the I_ENB when at least one active LID can not accept data
- If not enabled, the I_ENB signal will never be asserted in Link mode, possibly leading to fragments being discarded.

Minimum packet length

- Packets shorter than the minimum length will be optionally counted in the short packet counter.
- Range 0 – 255 in 1 byte increments

Maximum packet length

- Packets longer than the maximum length will be optionally counted in the long packet counter.
- Range 0 – 16,383 in 1 byte increments

Backpressure threshold

- Number of free segments allocated below which backpressure will be triggered for the LP

SPI-3 ingress interface

Multiple independent data streams can be transmitted over the physical SPI-3 port. Each of those data streams is identified by a SPI-3 logical port (LP). Data from a transfer on a SPI-3 logical port and the associated descriptor fields are synchronized to the configurable internal buffer segment pool.

Normal operation

Refer to [13. Glossary] for details about the SPI-3 interface.

- A SPI-3 interface (a physical port) is enabled by the SPI-3_ENABLE flag in the SPI-3 configuration register. A disabled interface tri-states all output pins and does not respond to any input signals.
- The interface is configured in PHY or Link layer mode by the LINK flag in the SPI-3 general configuration register.
- The interface supports a SPI-3 logical port number range [0..255], note that at most 64 logical ports can be configured.
- The SPI-3 interface supports data transport over either a 32 bit data interface or over one single 8 bit interface (data[7:0]) only. The selection is defined by the BUSWIDTH flag in the SPI-3 general configuration register.
- The SPI-3 interface is configured in byte mode or packet mode by the PACKET flag in the SPI-3 general configuration register.
- The SPI-3 interface supports over-clocking.
- Parity checking over data[31:0] is enabled by the PARITY_EN flag in the Table 50, SPI-3 general configuration register (register_offset=0x00). The parity type is defined by the EVEN_PARITY flag. Parity check results over the in-band port address and the data of a transfer are forwarded towards the packet fragment processor.
- SPI Exchange supports zero clock interval spacing between transfers.

SPI-3 ingress interface errors

Given an I_FCLK within specification, the SPI-3 will not dead lock due to any combination or sequence on the SPI-3 interface. The SPI Exchange detects for incorrect SOP/EOP sequences on a logical port. The following sequences are detected:

- Successive SOP (SOP-SOP sequence rather than SOP-EOP-SOP-EOP)
- Successive EOP (EOP-EOP sequence rather than SOP-EOP-SOP-EOP)

Detection of an illegal sequence results in the generation of an SPI-3 illegal SOP sequence event or SPI-3 illegal EOP sequence even generated. The event is associated to the physical port. The event is directed towards the PMON & DIAG module.

A clock available process detects a positive I_FCLK within a 64 MCLK clock cycle period. The result of this process is reported in the I_FCLK_AV flag in the Table 52 SPI-3 ingress fill level register (Block_base 0x0200 + Register_offset 0x02).

A status change from the clock available status to the clock not available status generates a maskable SPI-3 ingress clock unavailable interrupt indication, SPI3_ICLK_UN, in Table 62-Non LID associated interrupt indication register (Block_Base 0x0C00 + Register_offset 0x0C).

SPI-3 ingress Link mode

Refer to [Glossary] for details about the SPI-3 interface.

- The PHY pushes data into the device in blocks from 1 up to 256 bytes.
- The SPI Exchange provides backpressure for the SPI-3 ingress physical interface by the I_ENB signal. The I_ENB is asserted when at least one

active LID can not accept data. This feature is enabled by the BACKPRESSURE_EN flag in the SPI-3 ingress configuration register (register_offset = 0x01). When the flag is cleared the I_ENB signal will not be asserted, hence no backpressure can be generated.

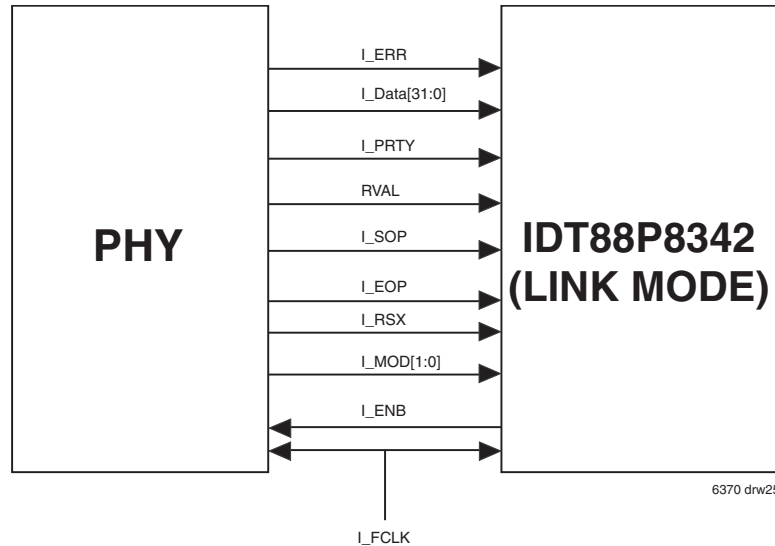

Figure 3. Link mode SPI-3 ingress interface

SPI-3 ingress PHY mode

The SPI Exchange indicates to the Link layer it has buffer space available by proper response to either Link layer polling (packet mode) or direct indication on DTPA signals (byte mode). The selection is made by the PACKET flag in the SPI-3 configuration register.

- In packet mode the device responds to polling (by Link layer device)
- In byte mode the direct status indication is limited to 4 addresses (fixed ports [3:0])

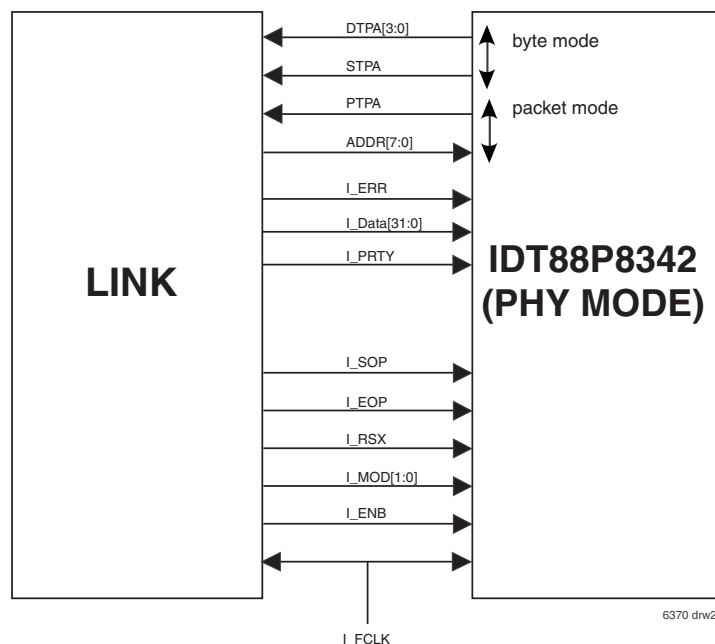

Figure 4. PHY mode SPI-3 ingress interface

3.1.2 SPI-3 egress

- All fragments will be of a programmable equal length with the exception of EOP fragment which may be shorter

LID to LP map

- 64 entries, one per LID, for each SPI-3 egress port
- LP enable control

Multiple burst enable

- Allows more than one burst to be sent to an LP.

Poll length

- For use when in Link mode and when using the packet level mode
- Causes polling of the PHY for the logical ports associated to LIDs ranging from [0 up to POLL_LENGTH] to find logical ports that can accept data
- Range is 0-63

Loopback enable

- Enables loopback from SPI-3 physical interface to same SPI-3 physical interface for test purposes

Data memory egress control

The SPI-3 egress port descriptor table (block_base 0x1700) for both paths out of the data memory. The function of the SPI-3 egress port descriptor table (block_base 0x1700) is to define where data goes after exiting the main data memory. There are four options configurable:

- SPI-3
- SPI-4
- Capture
- Discard

Maximum number of memory segments

- Defines the largest BUFFER available to a LP / LID
- Each segment is 256 bytes
- Range 1 – 508 in increments of one segment

SPI-3 egress interface configuration

- SPI Exchange allows for a pause at least two cycles of E_FCLK between successive transfers.
- SPI Exchange allows for over clocking for a higher clock frequency supported as opposed to the one defined by the SPI-3 implementation agreement.
- The Link mode is selected by the Link flag in the SPI-3 general configuration register.
- The interface operates in PACKET mode or BYTE mode as defined by the PACKET flag in the SPI-3 general configuration register.
- SPI Exchange generates even or odd parity over E_DATA[7/31:0] on the E_PRTY signal as defined by the EVEN flag in the Table 50, SPI-3 general configuration register (register_offset=0x00).
- SPI Exchange optionally generates two dummy cycles after assertion of the STX signal. The option is enabled by the STX_SPACING flag in the Table 50, SPI-3 general configuration register (register_offset=0x00).
- SPI Exchange optionally generates two dummy cycles after assertion of an EOP signal. The option is enabled by the EOP_SPACING flag in the Table 50, SPI-3 general configuration register (register_offset=0x00).

SPI-3 egress interface errors

A clock available process detects an E_FCLK cycle within a 64 MCLK clock cycle period. The result of this process is reported in the E_FCLK_AV flag in Table 58, *SPI-3 egress Fill Level Register (Block_base 0x0700 + Register_offset=0x03)*.

A status change from the clock available status to the clock not available status generates a maskable SPI-3 egress clock unavailable interrupt indication, SPI3_ECLK_UN, in Table 62-Non LID associated interrupt indication register (Block_Base 0x0C00 + Register_offset 0x0C).

SPI-3 egress Link mode

The SPI Exchange receives status information from the PHY. The PHY indicates its ability to receive data. Status information for all logical ports is directed towards the packet fragment processor.

Status information is received from the PHY.

- In packet mode, the SPI Exchange polls the PHY for the logical ports associated to LIDs ranging from 0 up to POLL_LENGTH to find logical ports that

can accept data. The POLL_LENGTH field is defined in the SPI-3 egress configuration register.

- In byte mode the SPI Exchange allows for direct status detection. This status information is directly forwarded to the packet fragment processor if enabled by the BURST_EN flag. When the BURST_EN flag is cleared the only one packet fragment per LP is allowed into the SPI-3 egress buffers.

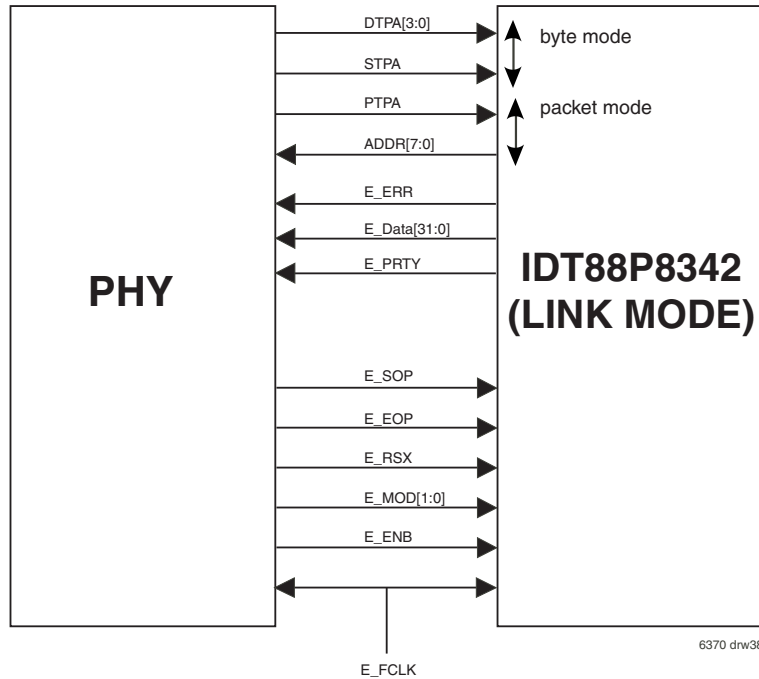

Figure 5. Link mode SPI-3 egress interface

SPI-3 egress PHY mode

In PHY mode, the SPI Exchange sends data to the attached Link-mode device as long as the E_ENB signal is asserted. The SPI-3 packet fragment processor transfers data to the SPI-3 egress buffers.

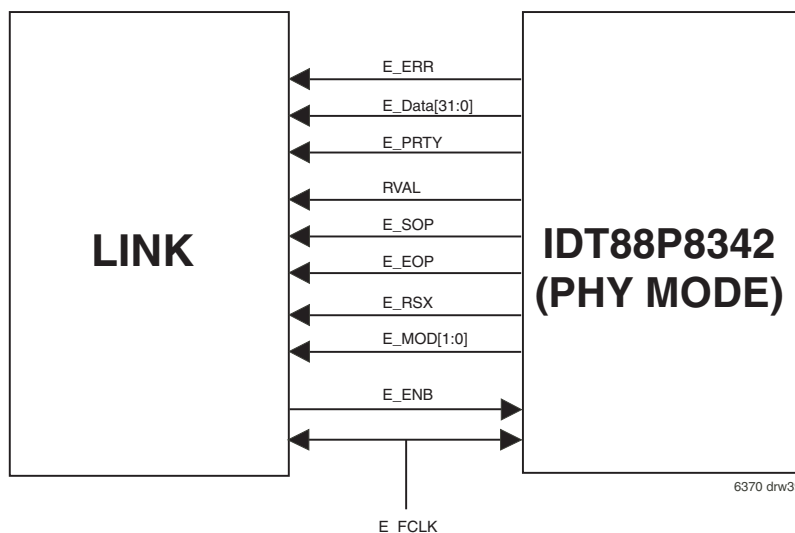

Figure 6. PHY mode SPI-3 egress interface

3.2 SPI-4

Refer to OIF SPI-4 document (see Glossary) for full details of the implementation agreement.

- Clock rate is 80 - 400 MHz (160 - 800MHz DDR)
 - Link and PHY modes supported
 - Address range 0 to 255 with support for 128 simultaneously active logical ports
 - MAXBURST parameters configurable 16-256 bytes in 16 byte multiples
 - 256 entry calendar
 - LVTTTL and LVDS status signals supported
- The following are implemented for the SPI-4 interface:
- Link / PHY layer device
 - Physical port active

3.2.1 SPI-4 ingress

The SPI-4 ingress includes

- Bit alignment
- Word alignment/de-skew
- Transfer decode and dispatch
- PFP interface
- Status frame generation

SPI-4 ingress configurable parameters

SPI-4 LID map

- 256 entries, one per SPI-4 LP
- SPI-3 physical interface identifier
- Physical port enable

Word / bit synchronization

- LVDS clock data alignment and LVDS data de-skew

Minimum packet length

- Packets shorter than the minimum length will be optionally counted in the short packet counter.
- Range 0 – 255 in 1 byte increments

Maximum packet length

- Packets longer than the maximum length will be optionally counted in the long packet counter.
- Range 0 – 16,383 in 1 byte increments

Free segment backpressure threshold

- Number of free buffer segments allocated to trigger backpressure for the LP

Data sampling

The I_LOW field in the Table 89 SPI-4 ingress configuration register (Block_base 0x0300 + Register_offset 0x00) selects an operating mode between 80 MHz and 200 MHz or between 200 MHz and 400 MHz.

Each lane is over-sampled by a factor of five. The over-sampled data is generated by a locked tapped delay line and clocked in to a register at the clock

rate. The current samples $c(n)$ and the previously generated samples provide samples for the eye computation. The optimized sampling point will be selected based on the eye computation. The tap selector is updated if necessary at the end of the eye pattern measurement interval. The tap selector moves no more than one tap at a time as a result of the eye pattern measurement.

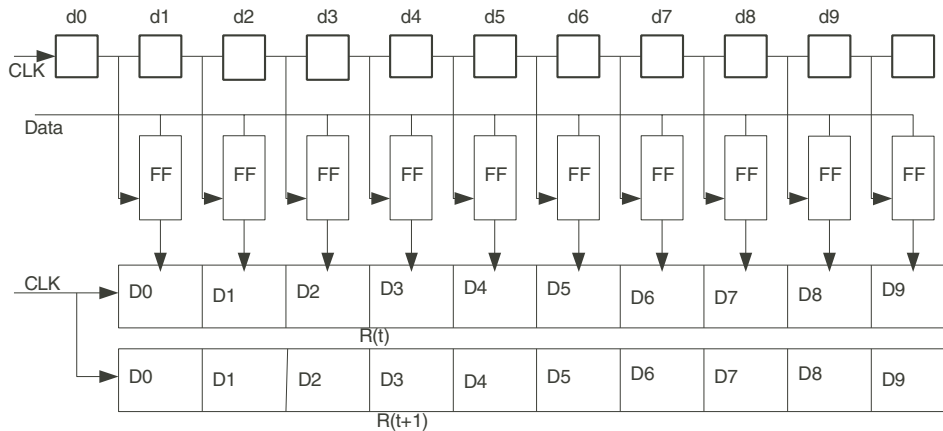

Figure 7. Data sampling diagram

Eye measurement

$$C[0] = R_t.D2 \wedge R_t.D3$$

$$C[1] = R_t.D3 \wedge R_t.D4$$

.....

$$C[7] = R_t.D9 \wedge R_{t+1}.D0$$

$$C[8] = R_{t+1}.D0 \wedge R_{t+1}.D1$$

$$C[9] = R_{t+1}.D1 \wedge R_{t+1}.D2$$

Accumulation results during a window defined by W are stored in the diagnostics table.

The latest result can be read out for diagnostic purposes.

Output tap selection

The sampling tap is automatically selected based on the eye measurement.

Manual phase selection

The automatic phase adjustment can be overruled by the processor when the FORCE flag is set see Table 99, SPI-4 ingress bit alignment control register (register_offset 0x11). The PHASE_ASSIGN field see Table 113, SPI-4 ingress manual alignment phase/result register (0x0C to 0x1F) now defines the selected phase.

Word alignment

The de-skew block searches for the Training Control Word 0x0FFF. If the Training Control Word is found, then training data is expected to follow the Training Control Word. The orthogonal training data will be used to align the word.

A de-skew control bit (I_DSC in Table 89-SPI-4 ingress configuration register at Block_base 0x0300 + Register_offset 0x00) is used to protect against a random data error during de-skew. If I_DSC=1, then two consecutive de-skew results are required. It is recommended to set I_DSC to a logic 1.

For diagnostics, an out of range offset between lines is provided. If the offset is more than two bits between the earliest and latest samples, I_DSK_OOR is set to a logic one. I_DSK_OOR is cleared to a logic zero when the offset is in range.

Transfer decode and dispatch

In the *OUT_OF_SYNC* state, the de-skew block will decode the transfer, and check the DIP-4 for validation.

A number of consecutive error free DIP-4 ingress bursts will lead to a transition to the *IN_SYNC*. The number is defined by the I_INSYNC_THR field in Table 89-SPI-4 ingress configuration register (Block_base 0x0300 + Register_offset 0x00).

In the *IN_SYNC* state, the PFP decodes the status transfer, check the DIP-4, and dispatches the data.

A number of consecutive DIP-4 errors will lead to the *OUT_OF_SYNC* state. The number is defined by the I_OUTSYNC_THR field in Table 89-SPI-4 ingress configuration register (Block_base 0x0300 + Register_offset 0x00).

A number of consecutive training patterns will lead to *OUT_OF_SYNC*. The number is defined by the STRT_TRAIN field in the Table 100 SPI-4 ingress start up training threshold register (Block_base 0x0300 + Register_offset 0x12). This feature is disabled if STRT_TRAIN=0.

Control word and data

A control word is distinguished by the SPI-4 RTCL signal. (logic one = control word).

DIP-4 check

For the DIP-4 check algorithm refer to the OIF SPI-4 document [Glossary]. In both *IN_SYNC* and *OUT_OF_SYNC* states, only control word previous and following data is checked. Any transition on synch status will be captured. In *IN_SYNC* state, each DIP-4 error is captured and counted.

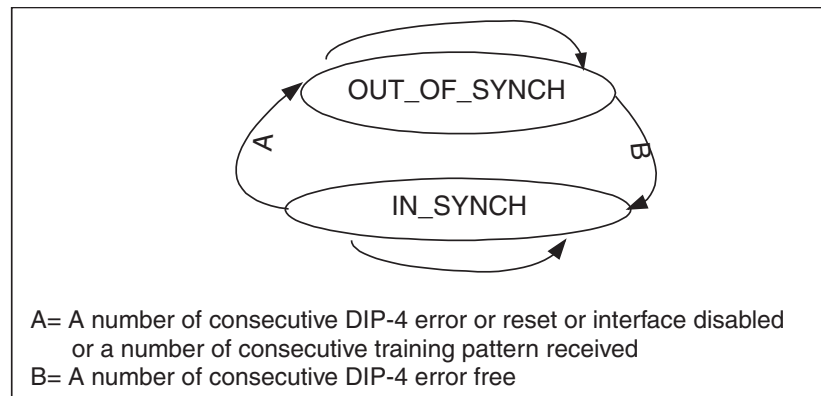

6370 drw35

Figure 8. SPI-4 ingress state diagram

Transfer decode

The SPI-4 ingress control word contains various fields. Refer to the OIF SPI-4 document [Glossary] for details. If reserved control word, BIT[15:12]=0011, 0001, 0101, or 0111 is detected, a BUS_ERROR event is generated. If a payload control word is not followed by a data word, or a data word does not follow a payload control word, a BUS_ERROR event is generated. If abort is detected, the next packet will be tagged with an error.

Data dispatch

The port address field of a payload control word is extracted as a search key. The search key is used to search the dispatch info in Table 86, SPI-4 ingress LP to LID map (256 entries, one per LP). If the searched port is active, transfer data is sent to the associated PFP with SOP, EOP, LENGTH, PACKET_ERROR. If the searched port is inactive, a SPI4_INACTIVE_TRANSFER event is

generated. A SPI-4 inactive transfer event with its associated LP will be captured in the Table 40, SPI-4 status register (0x22 in the direct accessed space).

SPI-4 ingress status channel Calendar structure and swapping

The SPI Exchange supports one or two sets of calendars. If I_CSW_EN field in the Table 89, SPI-4 ingress configuration register (0x00)=1, two sets of calendars are supported. A calendar selection word must be placed following the framing bit. Refer to the OIF SPI-4 document [see Glossary] for more details.

SPI-4 ingress status channel frame generation

The status frame can be one of the following cases:

- All '11' when LVTTL is in the out of synch state
- Training pattern when LVDS is in the out of synch state or in periodic training

- Normal status information when in the IN_SYNCH state

The normal status information is generated based on ingress buffer full information and PFP buffer segment fill level.

For information on DIP-2 generation and training pattern refer to the OIF SPI-4 document [Glossary].

DIP-2 error insertion

A number of consecutive DIP-2 errors can be generated. The I_DIP_E_NUM field in Table 97, SPI-4 ingress diagnostics register (register_offset 0x0F) specifies the number of errors to be generated. A logic one written to I_ERROR_INS will activate the I_DIP_E_NUM field and trigger error insertion. The I_ERROR_INS field self clears when the number of errors have been generated.

LVTTTL and LVDS status interface selection

The LVDS_STA pin selects which FIFO status interface is being used for SPI-4. HIGH = LVDS status interface, LOW = LVTTTL status interface.

3.2.2 SPI-4 egress

The SPI-4 egress includes

- Status channel synchronization
- Status updating
- Data transfer
- Periodic training
- PFP interface

SPI-4 egress configurable parameters

All parameters as listed in the OIF SPI-4 document [see Glossary]

CALENDAR_LEN: 4 to 1,024 in increments of 4

CALENDAR_M: 1 to 256 in increments of 1

MaxBurst1 (MaxBurst_S): 16 to 256 in increments of 16

MaxBurst2 (MaxBurst_H): 16 to 256 in increments of 16

Alpha: 1 to 256 in increments of 1

DATA_MAX_T: 1 to 4,294,967,040 in increments of 1

FIFO_MAX_T: 1 to 16,777,215 in increments of 1

Calendar and shadow calendar

- 256 entries

- E_CSW_EN field in Table 104, SPI-4 egress configuration register_0 (register_offset 0x00) bit for manual reconfiguration swap

Multiple burst enable

- Allows more than one burst to be sent to an LP. Feature included to relieve systems with long latency between updates.

SPI-4 egress LID to LP map

- 256 entries, one per SPI-4 LP

- Enable bit

3.2.3 SPI-4 startup handshake

TABLE 10 – BOTH ATTACHED DEVICES START FROM RESET STATUS

Ingress	egress
Out of synch, send status training	Out of synch, send data training
In synch, send status frame	Out of synch, send data training
In synch, send status frame	In synch, send data/idle

TABLE 11 – INGRESS OUT OF SYNCH, EGRESS IN SYNCH

Ingress	Egress
Out of synch, send status training	In synch, send data/idle
Out of synch, send status training	Out of synch, send data training
In synch, send status frame	Out of synch, send data training
In synch, send status frame	In synch, send data/idle

TABLE 12 – INGRESS IN SYNCH, EGRESS OUT OF SYNCH

Ingress	Egress
In synch, send status frame	Out of synch, send data training
Out of synch, send status training	Out of synch, send data training
In synch, send status frame	Out of synch, send data training
In synch, send status frame	In synch, send data/idle

SPI-4 egress status channel

Status channel bit alignment

The bit alignment algorithm for the status channel is the same as was described for the data channel.

Status Channel Frame synchronization

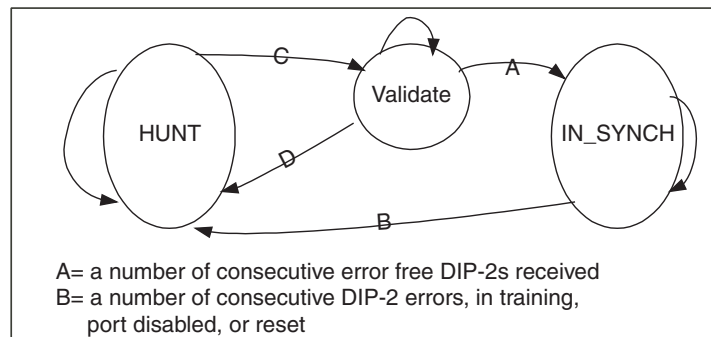

Figure 9. SPI-4 egress status state diagram

6370 dmv30

The status channel frame module has 3 states: HUNT, VALIDATE and IN_SYNC.

In the HUNT state, the status channel frame module searches for status frame, status clear and status freeze.

In the VALIDATE state, the status channel frame module checks DIP-2.

In the IN_SYNC state, the status channel frame module checks DIP-2, and updates status.

HUNT state

- In the HUNT state, per Link status is fixed to 'satisfied'.
- In HUNT state, the PFP searches frame continuously. It transitions to the VALIDATE state if a single frame is found accompanied by a single valid training pattern. A frame is considered to be found if: 1) only one frame word is at the beginning of a frame, 2) the calendar selection word, if enabled, is matched, and 3) the DIP-2 calculation matched the received DIP-2.

VALIDATE state

In the validate state, based on the frame found while in the HUNT state, the DIP-2 is checked.

If a single DIP-2 error is found, transition to the HUNT state.

After a number of consecutive DIP-2 calculations proves to be error free, transition to the IN_SYNC state. The number is defined by the E_INSYNC_THR field in Table 104-SPI-4 egress configuration register_0 (Block_base 0x0700 + Register_offset 0x00).

In the validate state, the training pattern is not checked.

IN_SYNC state

In the IN_SYNC state, training frame and status frame are checked.

DIP-2 is checked for status frame. Each mismatched DIP-2 will generate a DIP-2 error event, each event will be captured and counted.

After a number of consecutive DIP-2 errors, transition to the HUNT state. (Clear status in HUNT mode). The number is defined by the E_OUTSYNC_THR field in Table 104-SPI-4 egress configuration register_0 (Block_base 0x0700 + Register_offset 0x00).

The reception of twelve consecutive training patterns forces a transition to HUNT mode. If less than twelve consecutive training patterns are received, synch will not be lost, and status frame starts at the end of training.

Twelve consecutive '11' patterns force a transition to the HUNT state.

Status updating occurs without waiting for the end of a status frame.

Status channel de-skew

The LVDS status channel deskew uses the same algorithm as the data channel.

LVTTTL or LVDS status channel option

The LVDS_STA pin selects the interface type. A logic high enables the LVDS status interface. A logic low enables the LVTTTL status interface.

Data channel

Data transfer and training

At any cycle, the contents on the interface can be one of the following:

- Control word: Payload control word, or idle control word or training control word.
- Data word: Payload data word or training data word.

In the HUNT or the VALIDATE state, the training pattern is sent.

In the IN_SYNC state, data from is taken from the buffer segments and egressed to the SPI-4 interface. The switch between data burst, IDLE, and training must obey the following rules:

- Send IDLE if no data to transmit
- SOP must not occur less than 8 cycles apart.
- periodic training after current transfer finished

Payload control word generation:

- Bit 15, Control word type=1
- Bit [14:13] EOPS per [see Glossary: SPI-4]. If an error tag is in the descriptor, abort.
- Bit [12] SOP refer to [see Glossary: SPI-4]
- Eight Bit Address. Mapping table defined in Table 101, SPI-4 egress LID to LP map (128 entries)
- DIP-4 bit refer to [see Glossary]

Payload data word

- Bit order refer to [see Glossary: SPI-4]
- If only one byte is valid, 8 LSB (B7 to B0) is set to 0x00.

No status channel option

Once the NOSTAT bit is set, the status channel is ignored. Refer to Table 104, SPI-4 egress configuration register_0 (register_offset 0x00).

Status in default value.

No DIP error check.

No status updating, the received status fixed to STARVING.

Data channel works same as in IN_SYNC state.

3.3 Microprocessor interface

- Parallel microprocessor interface
 - 8 bit data bus for parallel operation
 - Byte access
 - Direct accessed space
 - Indirect access space is used for most registers
 - Read operations to a reserved address or reserved bit fields return 0
 - Write operations to reserved addresses or bit fields are ignored
- Serial microprocessor interface
 - Compliance to Motorola serial processor interface (SPI) specification
 - Byte access
 - Direct accessed space
 - Indirect access space is used for most registers
 - Read operations to a reserved address or reserved bit fields return 0
 - Write operations to reserved addresses or bit fields are ignored

General purpose I/O

Five general purpose I/O pins are provided. The direction is independently controlled by the DIR_OUT field in the GPIO register (Table 123 GPIO Register

(0x20)). The logical level on a pin is controlled by the LEVEL field in the GPIO register if DIR_OUT=1, or sensed if DIR_OUT=0. The LEVEL bit monitors the logic level of any bit selected from the indirect access space if MONITOR_EN is set high. A bit in the indirect access space can be selected for monitoring by the by the ADDRESS and BIT fields in the GPIO Link table (Table 124, *GPIO Monitor Table (5 entries 0x21-0x25 for GPIO[0] through GPIO[4])*).

All GPIO pins must be programmed into or out of monitor mode at the same time.

Interrupt scheme

Events are captured in interrupt status registers. Interrupt status flags are cleared by an microprocessor write cycle. A logical one must be written to clear the flag(s) targeted. A two level interrupt scheme is provided comprising a primary level and a secondary level.

The primary level identifies the secondary interrupts sources with a pending interrupt. This information is reflected in the primary interrupt register. Interrupt status can be enabled by associated flags both in the primary and secondary level of the interrupt scheme.

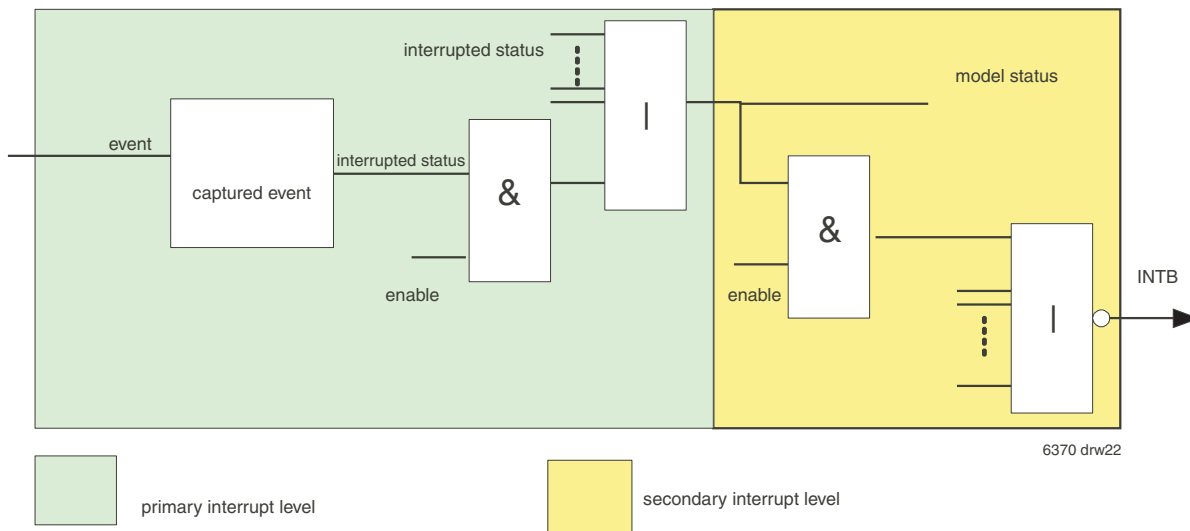

Figure 10. Interrupt scheme

4. DATAPATH AND FLOW CONTROL

The following sections describe the datapaths through the device. The datapaths shown are as follows:

- SPI-3A <-> SPI-4
- SPI-3B <-> SPI-4
- SPI-3A <-> SPI-3B
- SPI-3A <-> microprocessor interface
- SPI-3B <-> microprocessor interface
- SPI-4 <-> microprocessor interface

Where <-> indicates a bidirectional data path.

The IDT88P8342 supports two SPI-3 interfaces and a single SPI-4 interface. Both SPI-3 interfaces can operate independently in a PHY or Link mode. Refer to Figure 11, *Definition of Data Flows* for the main data flows in the device. Independent logical data flows are transported over each of the physical ports.

Those logical flows are identified by logical port addresses on the physical port and by a Link identification (LID) map in the core of the IDT88P8342.

DATA BUFFER ALLOCATION

Flexibility has been provided to the user for data buffer allocation. The device has 128 KByte of on chip memory per SPI-3 port per direction – a total of 1MByte of on-chip data memory.

The 128 KByte SPI-3 buffers (four instantiations per device) are divided into 256 byte segments. The segments are controlled by a packet fragment processor. The user configures the maximum number of segments per LP to allocate to a port and the number of segments allocated from the buffer segment pool that will trigger the flow control mechanism. There is no limitation on the reallocation of freed segments among logical ports, as would be present if the memory had been allocated by a simple address mechanism.

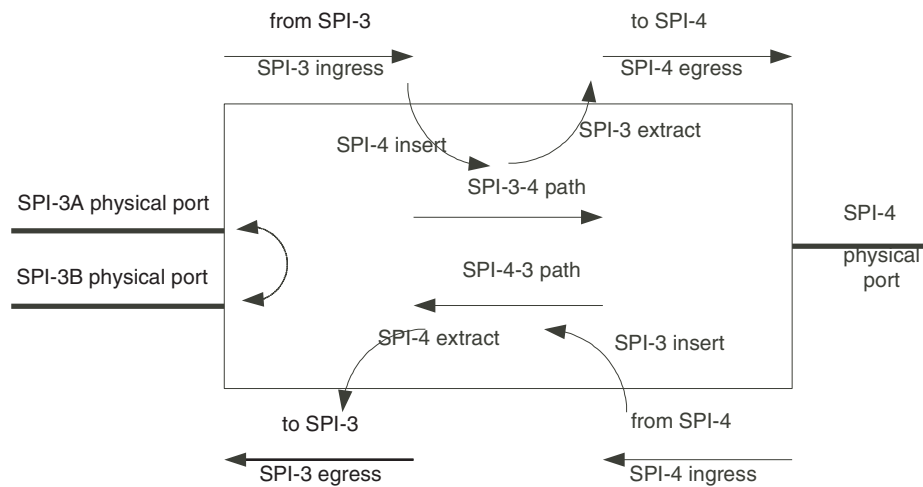

6371 drwXA

Figure 11. Definition of data flows

DATAPATH CONFIGURATION

A logical view of datapath configuration using Packet Fragment Processors is shown in Figure 12, *Logical View of Datapath Configuration Using PFPs*. Two PFPs are associated with each SPI-3 port, one for ingress and one for egress

Logical ports are mapped internally into Logical Identifiers (“LIDs”, “LID Map”) for the control of each per-LID data flow to each physical port, logical port, memory queue size, and backpressure threshold (watermark), by programming the LID register files.

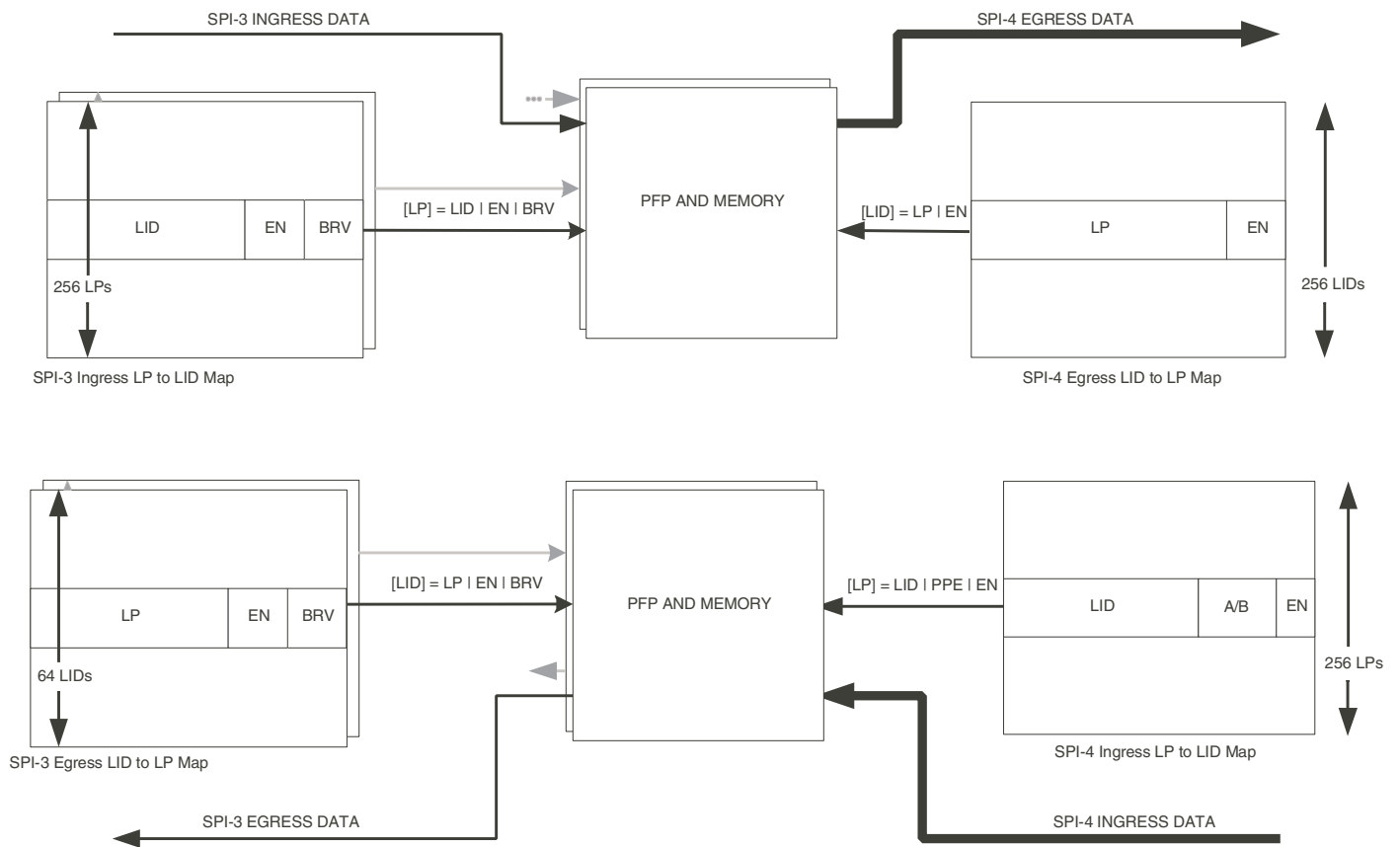

6371 dwnXB

Figure 12. Logical view of datapath configuration using PFPs

- LID - Logical Identifier
- EN - LID enable flag
- BRV - Bit reversal
- LP - Logical port
- PFP - Packet fragment processor

4.1 SPI-3 to SPI-4 datapath and flow control

Two packet fragment processor modules from SPI-3 to SPI-4 are provided. One packet fragment processor module is associated with one SPI-3 ingress interface. Both packet fragment processor modules connect to a single SPI-4 interface.

Packet fragments from the SPI-3 ingress are received into the SPI-3 ingress port buffers. A packet fragment processor transfers complete packet fragments from the SPI-3 ingress port buffers to memory segments previously reserved on a per-LP basis in the buffer segment pool. The SPI-3 ingress port buffer watermark and the per-LP free buffer segment threshold information is combined

to produce SPI-3 ingress FIFO status towards the attached device. Packets or packet fragments received on one SPI-3 ingress logical port can be forwarded to any one of:

A logical port on the egress SPI-4 interface.

A logical port on an associated SPI-3 interface (between physical port interfaces A and B only).

The microprocessor interface, using the capture buffer.

The connection on the logical port level is performed through an intermediate mapping to a Link Identification number (LID).

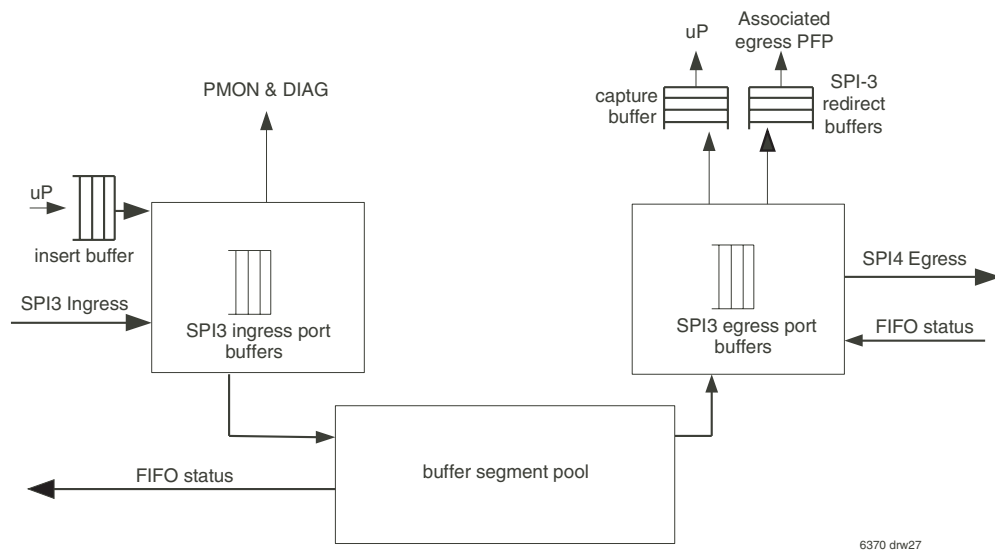

Figure 13. SPI-3 ingress to SPI-4 egress packet fragment processor

SPI-3 ingress PFP functions

The packet fragment processor (PFP) receives status information about the SPI-3 ingress buffers and the microprocessor insert buffer. The PFP processes SPI-3 ingress buffers in high priority and the insert buffer with low priority. The PFP copies data into the buffer segment, requests new buffer segments, and generates entries in the SPI4-egress queue.

SPI-3 ingress buffer processing

The PFP verifies whether a SPI-3 ingress buffer is occupied. If the SPI-3 ingress buffer is not occupied the PFP processes the insert buffer.

Normal operation

In loopback mode, all of the SPI-3 ingress buffers of a physical SPI-3 port are copied into the SPI-3 egress buffers of that same port. This is a test mode only, as no non-loopback traffic can be transferred at this time.

In non-loopback mode (normal operation) the SPI-3 ingress buffers are forwarded to the LID process by the PFP.

The LID process generates a set of events for an associated LID. The events that are directed towards the PMON&DIAG module are:

- SPI-3 error tagged packet event (errored packets)
- SPI-3 EOP event (all packets)
- SPI-3 fragment event (all fragments) with an associated length field

Erroneous operation

SPI-3 ingress buffers marked with an address parity error are always immediately flushed. A *SPI-3 flush event* is generated.

Store process

The process parameters are stored in a descriptor table. One entry in the table is required for each of the SPI-3 logical ports. Refer to Table 49, *SPI-3 ingress LP to LID Map*.

- Fragments tagged with an SOP indication trigger the buffer segment request process. The internal Packet_Length variable is initialized. The copy process is triggered.
- Fragments tagged with an EOP indication will trigger the packet length check process and the queue process.
- Non marked (EOP or SOP) buffers are subject to the copy process.

Buffer segment request process

A new buffer segment is requested for the logical port from the buffer segment pool.

The request can be accepted or rejected by the buffer pool.

When accepted, the Current_Seg and current Seg_Length variables are updated.

When rejected, the SPI-3 ingress buffer is flushed. An *SPI-3 flush event* is generated and directed towards the Table 61, Non LID associated event counters (0x00 - 0x0B). The buffer data is not copied into the SPI-4 buffer.

Copy process

Data is retrieved from the buffer and stored in the current segment. The data parity error status is stored in the Pack_Err variable. The Packet_Length variables and Seg_Length variables are updated. The queue and request processes are triggered when the number of bytes in the buffer segment equals the SPI-3 packet fragment size programmed for that physical interface, or an EOP is reached.

Queue process

The current segment is entered into the SPI-4 egress queue.

Packet length check

The length of the packet is compared to the MIN_LENGTH and MAX_LENGTH parameters in the ingress SPI-3 Port descriptor table. If the packet length is less than the programmed field MIN_LENGTH a *"SPI-3 too short packet event"* is generated. If the packet length is greater than the programmed field MAX_LENGTH a *"SPI-3 too long packet event"* is generated. The events are directed towards the Table 61, Non LID associated event counters (0x00 - 0x0B).

SPI-3 to SPI-4 buffer management

A 128 KB SPI-3 to SPI-4 buffer segment pool is assigned to each physical SPI-3 ingress port. A configurable part of this buffer segment pool is assigned to buffers associated to each of the up to 64 LIDs. The buffer size for a LID can be configured in multiples (M) of 256 bytes. Fewer LIDs allow larger buffers per LID, conversely a large number of LIDs will require smaller buffers per LID. Within this restriction, the buffer size of each LID can be further restricted as

needed to control latency. Modifications of the buffer size allocated to a LID are supported only when the logical port associated to the LID is disabled. Attempts to allocate more memory than available will generate an allocation error event. The indirect access module will discard the attempt.

Free buffer segment pool

Storage

The buffer segment pool is divided into 508 segments. The device holds a pool of free buffer segments. The buffer segment pool keeps track of the number of segments assigned to each LID and holds a list of free segments.

Buffer segment requests

A new segment for a logical Link (LID) can be requested from the buffer segment pool for that SPI-3 ingress physical port by the SPI-3 ingress packet fragment processor associated to that SPI-3 physical port. A request may be accepted immediately or rejected. When the request is accepted a buffer segment ID is returned immediately.

Buffer segment pool returned segments

A buffer segment can be returned to the buffer segment pool when the egress module releases it. This allows the segment to be used once more by the SPI-3 ingress.

SPI-4 egress queues

Normal operation

508 SPI-4 egress queue entries are provided. They are evenly allocated to the number of logical ports as defined by the static NR_LID configuration. One entry in the queue corresponds to a packet or a packet fragment to be forwarded to the SPI-4 egress interface.

SPI-3 ingress Backpressure

The module directs status signals for each of the 64 LIDs associated with a SPI-3 physical interface towards the SPI-3 ingress interface. The status signals request to transfer more data on the logical port associated to the LID. The available status is defined by the function (if free segments [LID] > Threshold, status = available).

SPI-4 egress direction control

The SPI-4 egress traffic can be captured by the microprocessor, directed to an associated SPI-3 egress port (SPI-3 port A to B, or port C to D, only), to the SPI-4 egress port, or discarded. The selection is defined for each of the 64 LIDs by the associated DIRECTION field in the Table 13, *Direction code assignment*.

TABLE 13 - DIRECTION CODE ASSIGNMENT

DIRECTION	Path
00	SPI-4
01	Associated SPI-3
10	Capture to microprocessor
11	Discard

SPI-4 egress data bursts

The PFP produces fragments of up to N*16 bytes. N is defined by the MAX_BURST_H or MAX_BURST_S parameter associated with each LID. For a high priority (starving) LID the MAX_BURST_S parameter is used. For a low priority (hungry) LID the MAX_BURST_H parameter is used. The PFP may not fill the buffers to the level granted when a new segment needs to be used in the SPI3-4 buffer memory or when the last fragment of a packet is copied into the buffer. The information received over the FIFO status channel is interpreted as status or credit information as selected by the CREDIT_EN flag in Table 78, SPI-3 to SPI-4 flow control register (0x01). If the status mode is used, data will be egressed until the status is changed. If the credit mode is used, the SPI-4 egress will issue only one credit's worth data burst and then wait for another credit from the status channel before issuing another LID burst.

SPI-4 egress FIFO status channel updates

The SPI-4 egress FIFO Status Channel Module continuously verifies the status information for the LIDs associated to SPI-4 logical ports. The PFP searches and selects a LID, fetches the associated information and queues data to the SPI-4 egress. The obsolete buffer segment is returned to the free buffer segment pool (unless the repeat test feature is enabled). Searching the LID to be served is performed for both a high priority and a low priority LID. The priority is defined by the status received from the SPI-4 egress module.

SPI-3 ingress logical port mapping

Each of the two SPI-3 interfaces has an associated SPI-3 ingress LP to LID map, (See Table 49) for the purpose of directing the packet fragments from its SPI-3 ingress to its associated SPI-3 ingress main memory buffer segment pool. The SPI-3 LID map has 256 entries, one per SPI-3 LP, but only 64 LPs are supported on any SPI-3 interface at any one time. Each SPI-3 interface has an enable bit, as well as the ability to reverse the bit ordering of the interface. The packet fragment length is associated with a SPI-3 interface. The allowed range is 0 to 255 bytes per packet fragment. The last fragment of a packet can be shorter than the programmed fragment size. Each SPI-3 port can be independently set for either Link or PHY mode of operation.

SPI-3 ingress LID associated control

Each LID on a SPI-3 interface has the ability to be programmed for minimum and maximum packet length. The minimum packet length can be set from 0 to 255 bytes in one byte increments. The maximum packet length can be set from 0 to 16,383 bytes in one byte increments. Each LID can be enabled and disabled independently.

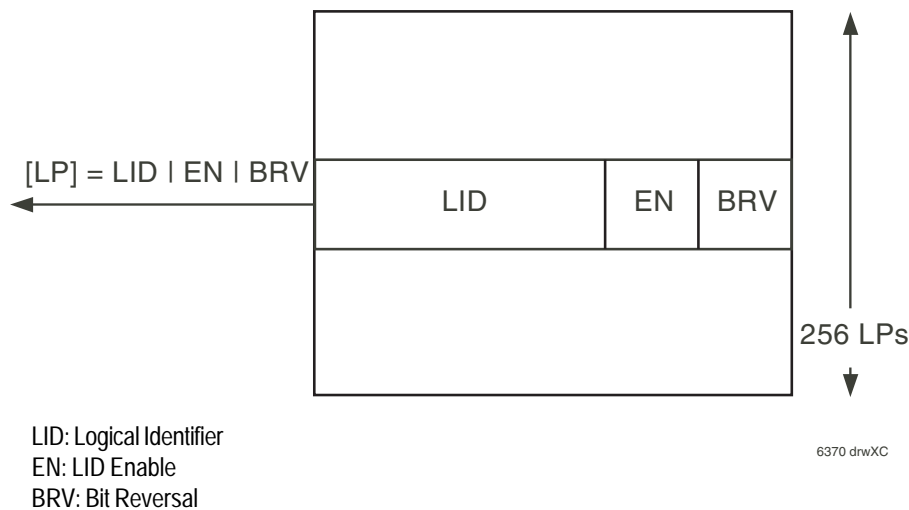

Figure 14. SPI-3 ingress LP to LID map

SPI-4 egress interface port associated control

The SPI-4 interface has an associated LID to LP map (See Table 101 - SPI-4 egress LID to LP Map Block_base 0x0400 = Register_offset 0x00 - 0xFF) for the purpose of directing the packet fragments from the selected SPI-3 ingress main memory buffer segment pool to the SPI-4 egress interface. The SPI-4 LID map has 256 entries, one per LID. The SPI-4 interface has an enable bit. The burst length is associated with the SPI-4 interface. The allowed burst range is 16 to 256 bytes per burst. The last burst of a packet can be shorter than the programmed burst size.

SPI-4 egress LID associated control

Each of the 256 entries in the SPI-4 egress LID to LP map (See Table 101 - SPI-4 egress LID to LP Map (256 entries)) is used to control the pulling of bursts out of the buffer segment pool and into the SPI-4 egress interface. Each LID can be enabled and disabled independently.

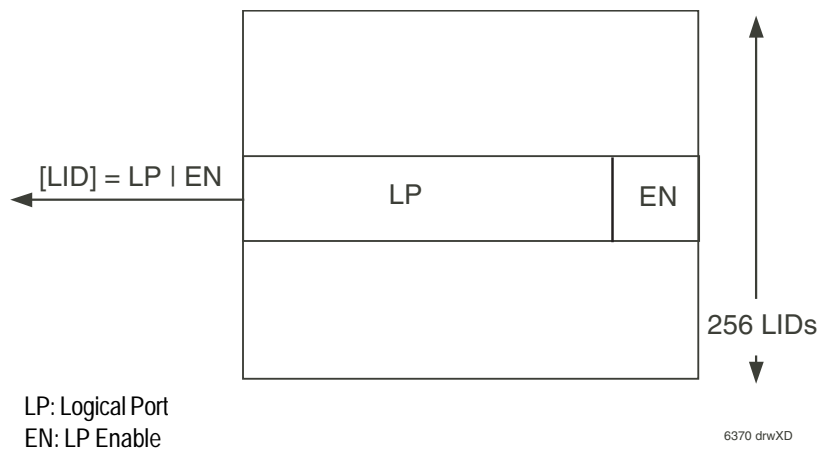

Figure 15. SPI-4 egress LID to LP map

The diagram below shows the datapath through the device from a SPI-3 ingress interface to the SPI-4 egress interface.

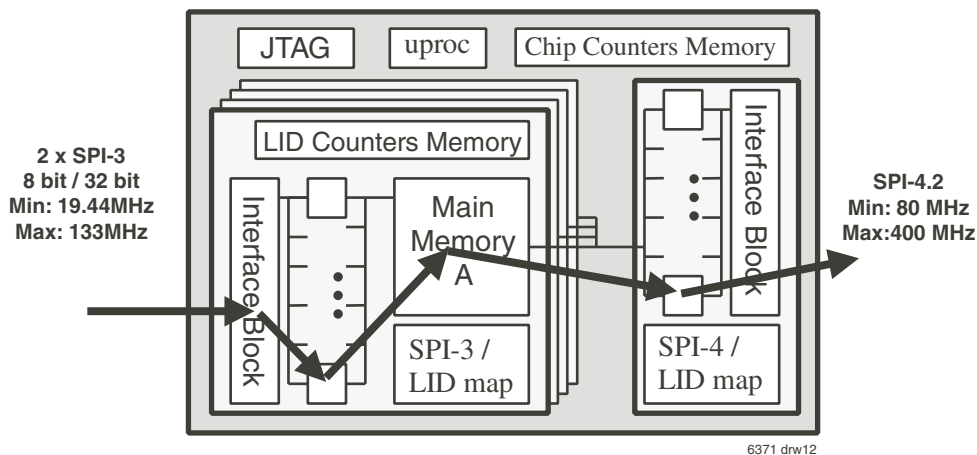

Figure 16. SPI-3 ingress to SPI-4 egress datapath

SPI-3 ingress to SPI-4 egress flow control

For control information there are two separate cases to consider: The case that the SPI-3 physical interface port is configured in Link mode, and the case that the SPI-3 is configured in PHY mode. Note that since the SPI-3 physical interfaces are configured separately, the device is able to deal with the case that some of the LP fragments have been received on a Link layer device SPI-3 interface and some have been received on a PHY layer device SPI-3 interface.

For a device in Link mode the Link device can only control the flow of data through the RENB signal. Two modes of operation are implemented and configurable for flow control on this interface – either the data can be allowed to flow freely into the device or the RENB signal will be asserted if a condition arises that one of the LPs is unable to receive another fragment. The first of these modes is considered to have no Link layer device flow control, and the second has Link layer device flow control.

For the no Link flow control mode, any data sent to an LP unable to receive another fragment will cause an LP overflow.

For a device in Link mode the Link has complete knowledge of the fill level of the data buffers in each of the LPs in the PHY. This knowledge is attained either through byte level polling or packet level polling.

Both in Link and PHY modes, the data is collected to buffer segments associated with an LP. The SPI-4 PFP is updated with the number of free segments available to the LP. The SPI-4 PFP determines which LP to service based on two factors: whether the LP contains enough data for a burst, and the starving / hungry / satisfied state of the LP. For details on the mapping of LPs to LIDs, refer to Table 101 - SPI-4 egress LID to LP Map Block_base 0x0400 = Register_offset 0x00 - 0xFF.

SPI-3 ingress flow control registers

The following are implemented per SPI-3 interface, and there are two instantiations per device.

Backpressure enable

Link mode only
 Enables the assertion of the I_ENB pin when at least one active LID cannot accept data
 If not enabled, the I_ENB signal will never be asserted in Link mode, possibly leading to fragments being discarded.

SPI-4 egress flow control configurable parameters

- All parameters as listed in SPI-4 implementation agreement:
- CALENDAR_LEN: 4 to 1,024 in increments of 4
- CALENDAR_M: 1 to 256 in increments of 1
- MaxBurst1 (MaxBurst_S): 16 to 256 in increments of 16
- MaxBurst2 (MaxBurst_H): 16 to 256 in increments of 16
- Alpha: 1 to 256 in increments of 1
- DATA_MAX_T: 1 to 4,294,967,040 in increments of 1
- FIFO_MAX_T: 1 to 16,777,215 in increments of 1

SPI-4 egress flow control calendar and shadow calendar
 256 entries

SPI-4 egress flow control multiple burst enable

Allows more than one burst to be sent to an LP. This feature was included to increase throughput in systems with long latency between updates.

The diagram below shows the SPI-3 ingress to SPI-4 egress flow control Path through the IDT88P8342 device.

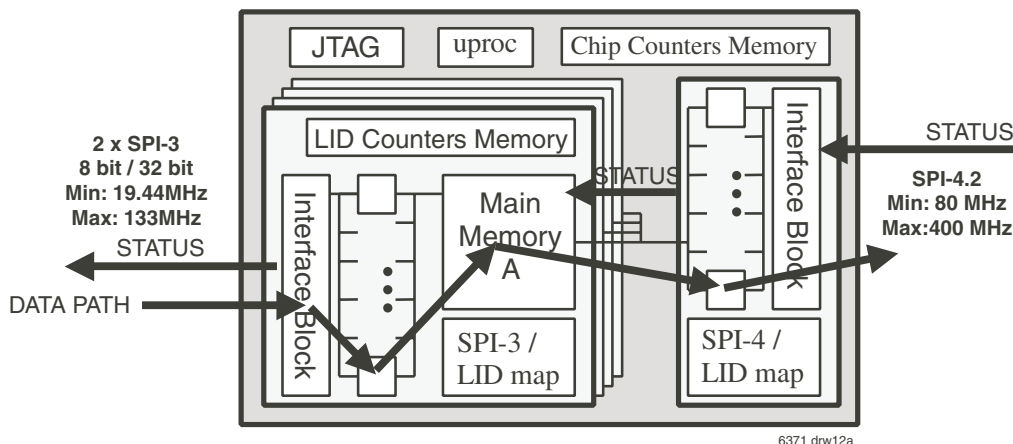

Figure 17. SPI-3 ingress to SPI-4 egress flow control path

4.2 SPI-4 to SPI-3 datapath and flow control

Two Packet Fragment Processor modules from SPI4 ingress to SPI-3 egress are provided, all connected to one SPI-4 ingress interface.

Packet bursts from the SPI-4 ingress are received into the SPI-4 ingress port buffers. A packet fragment processor transfers complete packet bursts from the SPI-4 ingress port buffers to memory segments previously reserved on a per-LP basis in the buffer segment pool. The SPI-4 ingress port buffer watermarks and the per-LP free buffer segment threshold information is combined to produce SPI-4 ingress FIFO status (per-LP starving, hungry, or satisfied) towards the attached SPI-4 device. Per-LP buffer segment threshold information is used to produce FIFO status information for the attached SPI-3 device. Packets or packet fragments are forwarded to the SPI-3 interface when a packet is complete or a predefined number of bytes have been received. Packets or packet fragments received on one SPI4 logical port are cross connected to an SPI3 logical port through an intermediate mapping to a Link identification, or LID. Its mode of operation is similar to the SPI-3 ingress to SPI-4 egress packet fragment processor, with the following differences:

- 1) The PFP4-3 data input has three sources, listed in descending priority: SPI-4 buffers, redirect buffers, and insert buffers.
- 2) The PFP3-4 data output has only three destinations. There is no SPI-3 to SPI-4 redirect path.

Each SPI-3 interface feeds ingress buffer available or ingress buffer unavailable status information to its packet fragment processor.

If the number of free segments available to a LP exceeds the starving threshold, the SPI-4 status is moved to starving for that LP. If the number of free segments available to a LP exceeds the hungry but not the starving threshold, the SPI-4 status is moved to hungry for that LP. If the hungry threshold is not exceeded, the SPI-4 FIFO status channel will indicate satisfied for that LP.

SPI-4 ingress to SPI-3 egress datapath

The following is a description of the path taken by a burst of data through the device from the SPI-4 ingress to a SPI-3 egress.

Data enters on the SPI-4 ingress interface in bursts. Bursts are normally of equal length except the last burst of a packet which may be shorter. The control word is in-band with the data. Burst data enters a SPI-4 ingress buffer. SPI-4 LP address, error information, SOP, EOP are stored with the burst data. A SPI-4 LP address is mapped to a Logical Identifier (LID). The burst is stored in per LID allocated buffer segments reserved from the buffer segment pool.

The appropriate SPI-3 egress control register (Table 80 - SPI-3 egress Port Descriptor Table (64 entries)) is consulted, and it determines to send this LID to a prescribed SPI-3 egress port.

The selection of which LP is to be transmitted next is dependent on the status of the LP and the availability of a complete fragment. Data is moved to the appropriate SPI-3 egress buffer along with the LP address. SPI-3 LP address, error information, SOP, and EOP information is stored with the packet fragment. Next, data is transmitted in packet fragments over the selected SPI-3 interface.

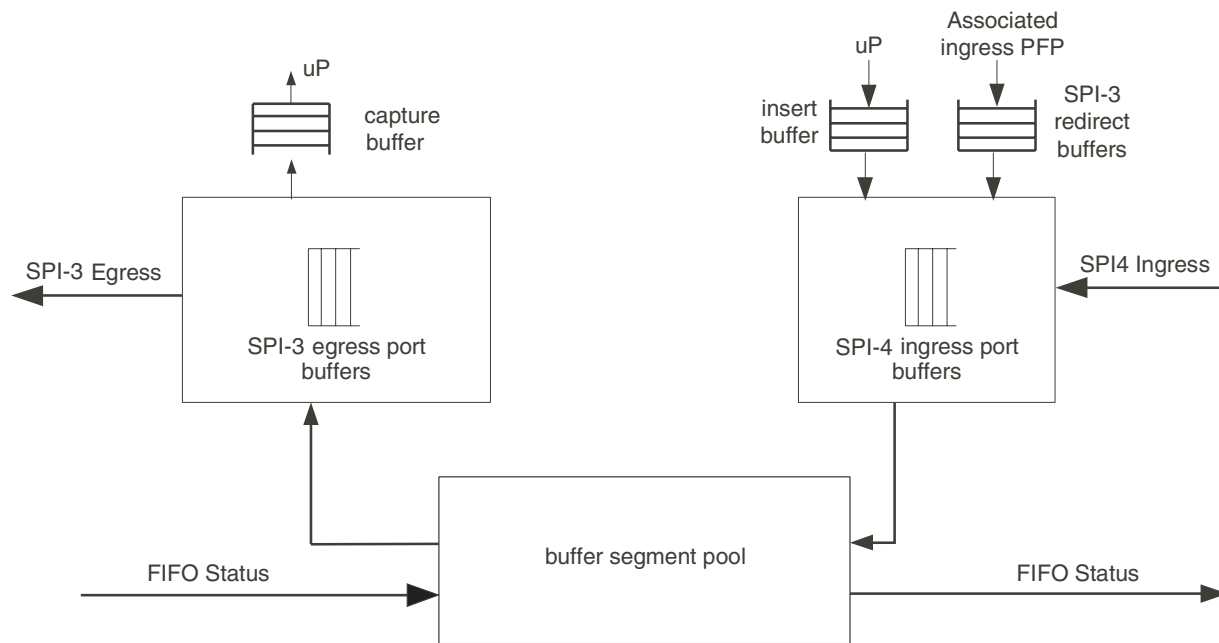

6370 drw37

Figure 18. SPI-4 ingress to SPI-3 egress packet fragment processor

SPI-4 ingress interface configurable parameters:

The IDT88P8342 can interface to either a Link or a PHY layer device. The SPI-4 port can be enabled or disabled.

The SPI-4 ingress bits are aligned with the ingress clock. In addition, the SPI-4 words are then aligned among each other to produce valid words. This is performed both on the data channel and the status channel. The bit alignment algorithm runs as long as the interface is active. The word alignment algorithm is run during training intervals.

SPI-4 ingress per-LID configurable parameters

SPI-4 to SPI-3 LID map

- 256 entries, one per SPI-4 LP
- SPI-3 physical interface identifier
- SPI-3 LID
- Enable bit per LID

SPI-4 ingress packet length check

Each LID on the SPI-4 ingress interface has the ability to be programmed for minimum and maximum packet length. The minimum packet length can be set from 0 to 255 bytes in one byte increments. The maximum packet length can be set from 0 to 16,383 bytes in one byte increments. Packets shorter or longer than set by these parameters will be optionally counted in the short or long packet counter for that LID.

SPI-3 egress configurable parameters

Length of SPI-3 packet fragment

All packet fragments from a particular SPI-3 physical interface are programmable to an equal length with the possible exception of an EOP fragment which may be shorter.

SPI-3 egress poll length

Applies when the SPI-3 interface is acting as a Link layer device when using the packet level polling mode

Causes polling of the PHY for the logical ports associated with LIDs ranging from [0 up to POLL_LENGTH] to find logical ports that can accept data

Poll range is 0-63 LPs.

SPI-3 egress per-LID configurable parameters

Many parameters to control the flow of data are programmable per LID. The following paragraphs describe these parameters.

SPI-3 egress LID to LP map

- one map per SPI-3 physical port
- 64 entries per map, one per LID
- LP enable bit per LP
- Bit reversal enable per LP

SPI-3 egress multiple burst enable

Multiple Burst Enable allows more than one burst to be sent to an LP. This feature is included to relieve systems with long latency between updates. When this feature is not enabled, only one burst per LP is allowed into the round robin SPI-3 egress buffers at a time.

SPI-4 ingress to SPI-3 egress data memory

SPI-3 egress control

There is a SPI-3 egress port descriptor table for the paths out of the data memory. The function a SPI-3 egress port descriptor table is to define where data goes after leaving the main data memory. There are three configurable options:

- SPI-3 egress
- Microprocessor Interface Capture
- Discard

Maximum number of memory segments

- Defines the largest Buffer available to an LP / LID
- Each segment is 256 bytes
- Range 1 – 508 in increments of one segment

The figure below shows the datapath through the device from the SPI-4 interface to the SPI-3 interface.

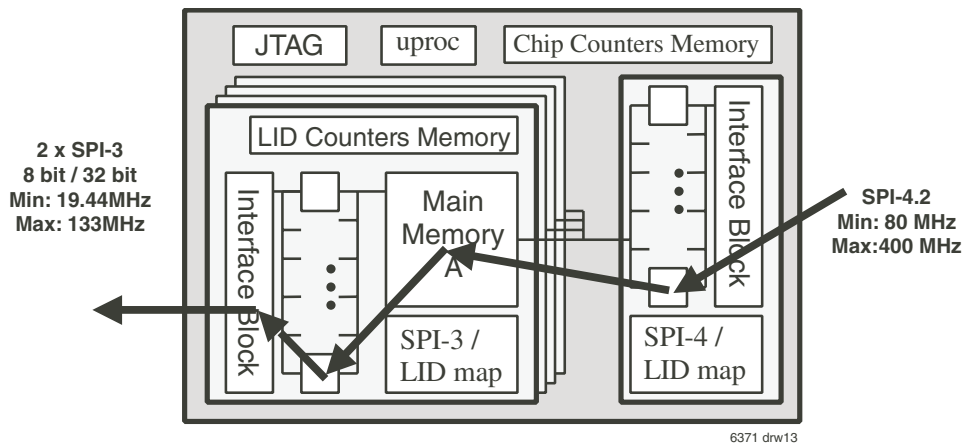

Figure 19. SPI-4 ingress to SPI-3 egress datapath

SPI-4 ingress to SPI-3 egress flow control

The SPI-4 control information is transmitted to the adjacent device. The adjacent device determines which LP to service next according to the status information it receives from the IDT88P8342. The SPI-4 ingress data arrive in bursts that are of equal length except for the last burst of a packet which may be shorter.

The SPI-4 burst data is transferred to the per LID allocated buffer segments. The addition of the data may cause an update of the SPI-4 status information (starving, hungry, satisfied), and may change the SPI-3 STPA, DTPA, or PTPA signals when in PHY mode.

For the control information there are two separate cases to consider: the case that the SPI-3 is configured to Link mode, and the case that the SPI-3 is configured

to PHY mode. Note that since the SPI-3 physical interfaces are configured separately, the IDT88P8342 device is able to deal with the case that some of the LP fragments are to be transmitted on a Link SPI-3 interface and some are to be transmitted on a PHY SPI-3 interface

When in PHY mode, the data is sent according to the availability of the data in the buffer segment pool. In the Link mode an extra consideration is taken to account – that of the fill level of the ingress FIFOs in the adjacent device.

Backpressure threshold

- Number of free segments allocated to trigger backpressure for the LP

The diagram below shows the SPI-4 to SPI-3 flow control path through the IDT88P8342 device.

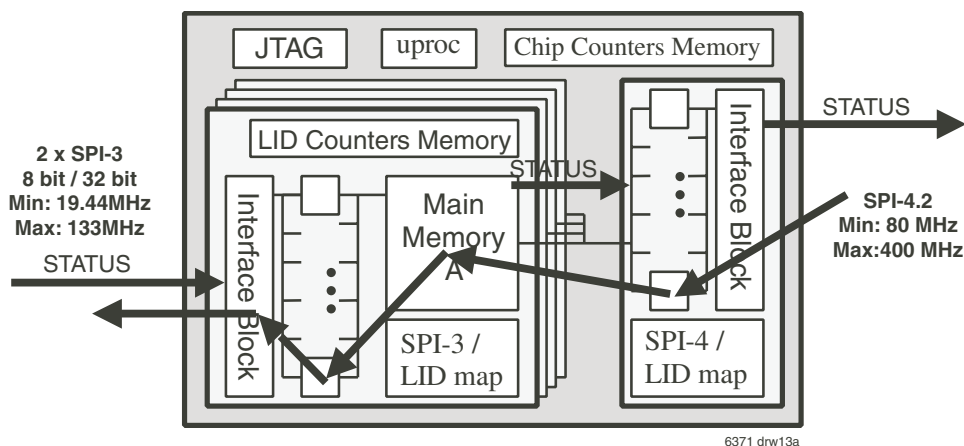

Figure 20. SPI-4 ingress to SPI-3 egress flow control

4.3 SPI-3 ingress to SPI-3 egress datapath

The SPI-3 redirect buffer can store SPI-3 packet fragments. The status of the packet fragment buffers is forwarded to the associated packet fragment processor. The purpose of the SPI-3 redirect is to enable per-LP flows between physical interfaces SPI-3 A and SPI-3 B. Other flows between SPI-3 ports are not allowed; *i.e.*, between A and A, and between B and B.

The following is a description of the path taken by a fragment of data through the device.

A SPI-3 to SPI-3 path is between an LP on one SPI-3 to the paired SPI-3. Data enters on the SPI-3 interface in fragments. Fragments are of equal length except the last fragment of a packet which may be shorter. The LP address is in-band with the data. The packet fragment enters an ingress buffer. SPI-3 LP address, error information, SOP, and EOP information is stored with the fragment. The LP address is mapped to a LID. The fragment is stored in buffer segment pool per-LID-allocated memory space.

The Table 80, SPI-3 egress port descriptor table (64 entries) is consulted, and the PFP decides to send a LID to the associated SPI-3 egress port. The SPI-3 packet fragment processor chooses the next LP. The choice of LP is dependent on status of the LP and availability of a complete fragment. Data is moved to an egress buffer along with the SPI-3 LP address, error information, SOP, and EOP information. Data is transmitted in packet fragments over a SPI-3 interface.

The paths to and from the microprocessor interface can be used to perform mappings from a SPI-3 LP to a SPI-3 LP where not provided, and from a SPI-4 to a SPI-4 LP. However these paths are limited by the bandwidth of the microprocessor interface.

The diagram below shows the datapath through the device from a SPI-3 interface to its paired SPI-3 interface. For the SPI-3 redirect, the LID connecting associated port pairs must be the same in both directions.

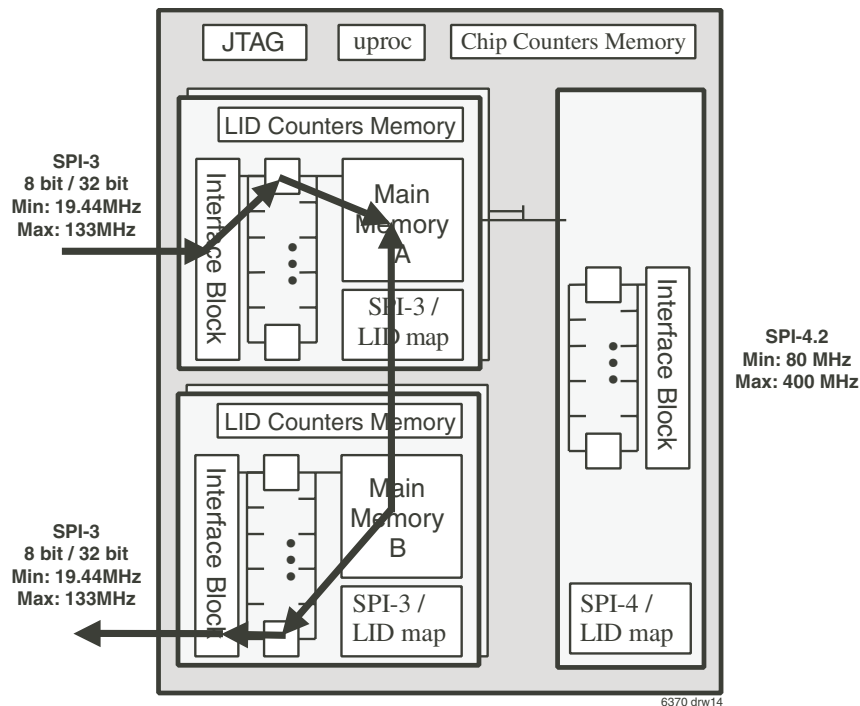

Figure 21. SPI-3 ingress to SPI-3 egress datapath

4.4 Microprocessor interface to SPI-3 datapath capture/insert configurable parameters

Enable insertion / capture of data to the SPI-3 or SPI-4 data stream (which is dependent on the egress control register). For each direction, the following are to be used:

- Data for insertion or data captured
- Data available: set when data is available. Asserted by device for capture, asserted by microprocessor for insertion.
- LID: Logical Identifier of capture / insertion channel
- Length: length of data for insertion or capture
- Flags: SOP, EOP, address parity error, data parity error, packet error

There are separate instantiations of microprocessor insert capture buffers for SPI-3 and SPI-4.

Capture data fragment

Packets can be captured from the SPI-3-4 stream and directed towards the microprocessor. The capture buffer can store only one 256 byte packet fragment. When the buffer is full the DATA_AVAILABLE flag is set and a SPI-3 capture event is generated. The event is directed towards the interrupt module.

Read packet data fragment

The microprocessor needs to read a buffer to capture a packet fragment. It verifies the DATA_AVAILABLE flag in the SPI-3 capture control register. Microprocessor reads the packet fragment and EOP, SOP, ERROR, LID and LENGTH fields from the SPI-3 data capture buffer. Microprocessor hands over control of the capture buffer when it clears the DATA_AVAILABLE flag in the SPI-3 data capture control register (Table 31 - SPI-3 data capture control register).

4.4.1 SPI-3 to ingress microprocessor interface datapath

The diagram below shows the datapath through the device from the SPI-3 interface to the microprocessor capture interface.

The following is a description of the path taken by a fragment of data through the device.

Data enters on a SPI-3 interface in fragments. Fragments are of equal length except the last fragment of a packet which may be shorter. The LP address is in-band with the data. The fragment enters a SPI-3 ingress buffer. SPI-3 LP address, error information, SOP, and EOP are stored with the fragment. The LP address is mapped to a LID. The fragment is stored in LID allocated buffer segments.

The Table 80, SPI-3 egress port descriptor table (64 entries) is consulted, and the PFP decides to send this LID to the microprocessor capture port. Data is moved to the capture buffer along with the LP address. LID, error information, SOP, and EOP. The data available bit is set. Data and control information are read from the relevant register space through the microprocessor interface.

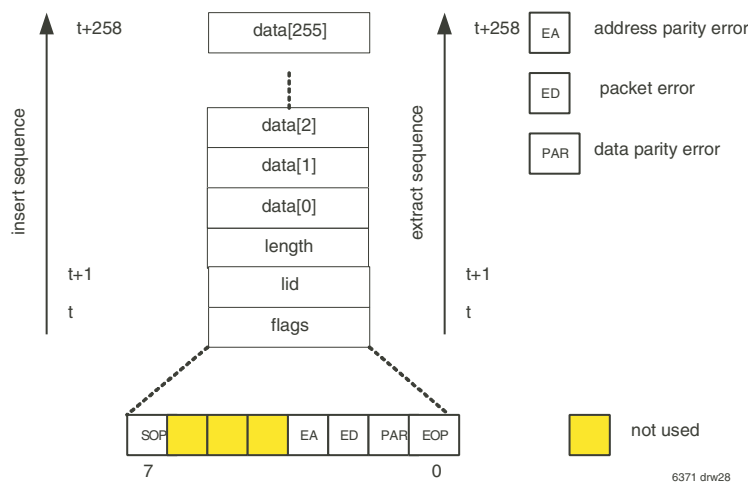

Figure 22 . Microprocessor data capture buffer

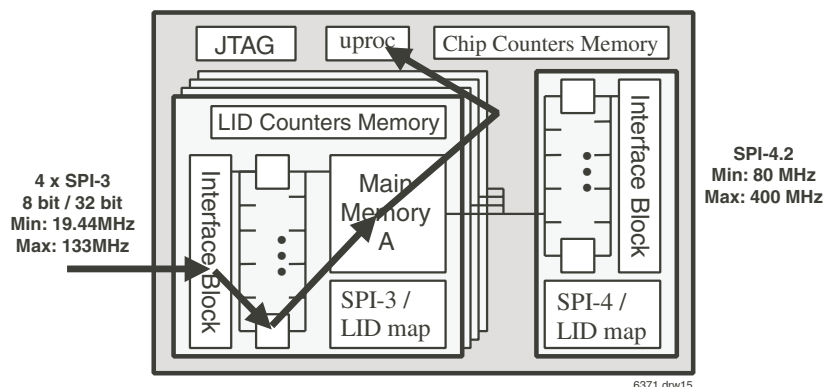

Figure 23. SPI-3 ingress to microprocessor capture interface datapath

4.4.2 Microprocessor insert to SPI-3 egress datapath

The diagram below shows the datapath through the device from the microprocessor data insert interface to a SPI-3 egress port.

The following is a description of the path taken by a fragment of data through the device.

Data and control information are written to the insert buffer through the microprocessor interface. The data available bit is set. Data is stored along with its LP address, LID (including SPI-3 choice), error information, SOP, and EOP.

Data is stored in LID-allocated buffer segments. The Table 80, SPI-3 egress port descriptor table (64 entries) is consulted and the PFP decides to move the data to the SPI-3 egress port. The SPI-3 packet fragment processor chooses the next LP. The choice of LP is dependent on the status of the LP and the availability of a complete fragment. Data is moved to a SPI-3 egress buffer along with its LP address. SPI-3 LP address, error information, SOP, and EOP.

Data is transmitted in packet fragments over the selected SPI-3 egress interface.

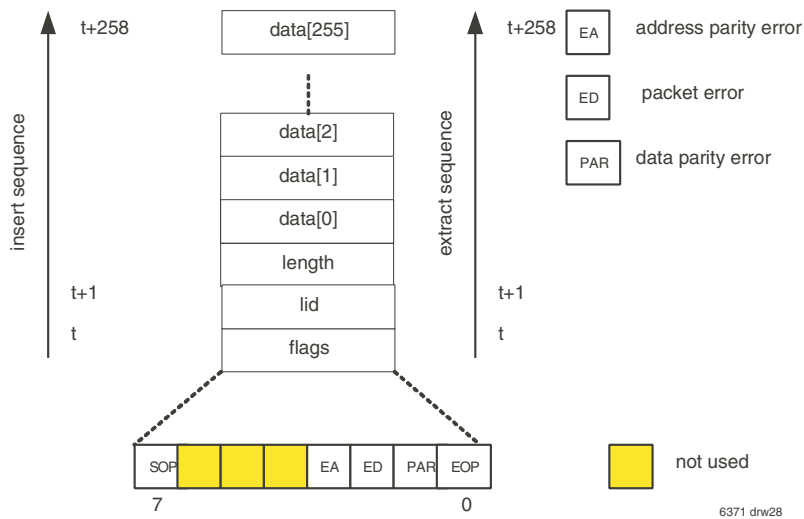

Figure 24 . Microprocessor data insert buffer

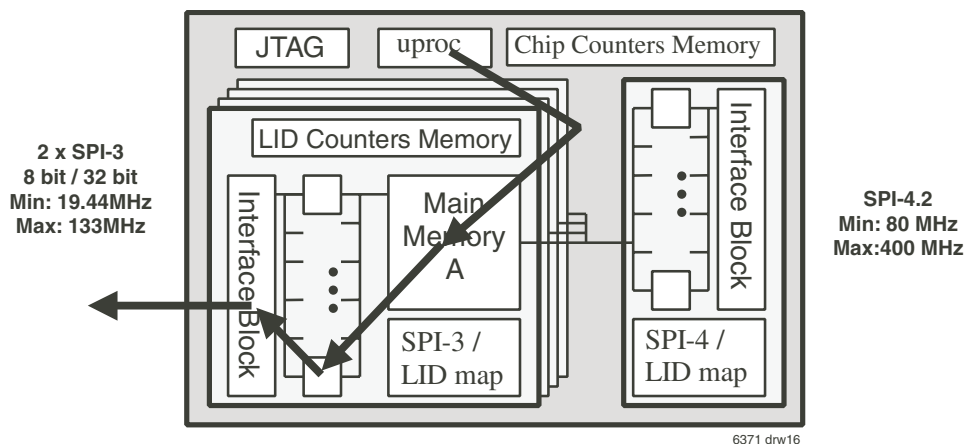

Figure 25. Microprocessor interface to SPI-3 egress detailed datapath diagram

4.4.3 Microprocessor interface to SPI-4 egress datapath

Packets can be inserted into the SPI-3-4 datapath by the microprocessor. The following is a description of the path taken by a burst of data through the device.

Data and control information are written to the insert buffer through the microprocessor interface. The data available bit is set. Data is stored in the insert buffer along with the LP address, LID, error information, SOP, and EOP. Data is stored in per-LID allocated buffer segments. The Table 36-SPI-3 data insert control register is consulted, and determines to send this LID to the SPI-4 egress port. The SPI-4 Packet Fragment Processor chooses the next LP. Data is sent to the SPI-4 egress buffer along with the SPI-4 LP address, error information, SOP, and EOP. Data is transmitted in bursts over the SPI-4 egress interface.

The microprocessor needs to write data into a dedicated buffer to insert a packet burst. Refer to Figure 26, *Microprocessor data insert buffer* for the data format in the buffer. The microprocessor must verify the DATA_AVAILABLE flag in the *SPI-4 insert control register* and waits until the flag is cleared. The microprocessor specifies the EOP, SOP, ERROR, LID and LENGTH fields and writes up to 256 bytes of packet fragment burst into the insert buffer. The packet burst insert buffer is accessed through the Table 34, SPI-4 data insert register (register_offsets 0x03 and 0x0B) *SPI-4 data insert register*. The microprocessor hands over control of the buffer setting the DATA_AVAILABLE flag in the *SPI-4 insert control register*. A *SPI4_insert_empty event* is generated when the DATA_AVAILABLE flag is cleared. The event is directed towards the interrupt module.

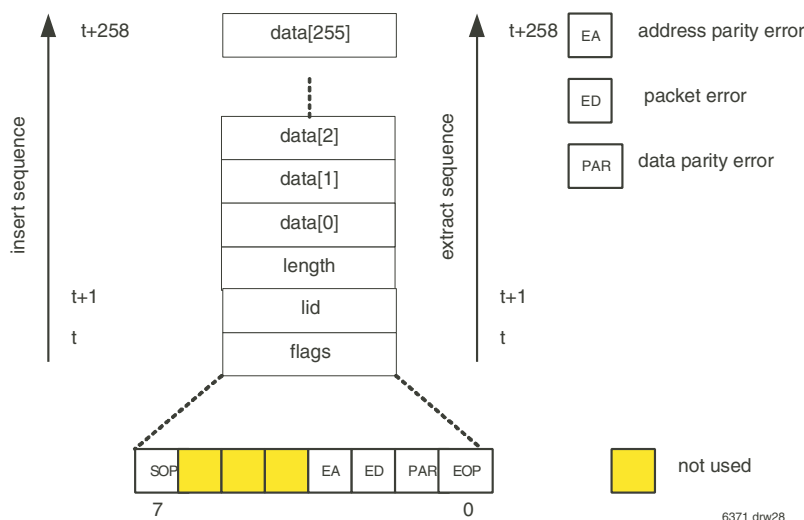

Figure 26. Microprocessor data insert buffer

The diagram below shows the datapath through the device from the microprocessor data insert interface to the SPI-4 egress interface.

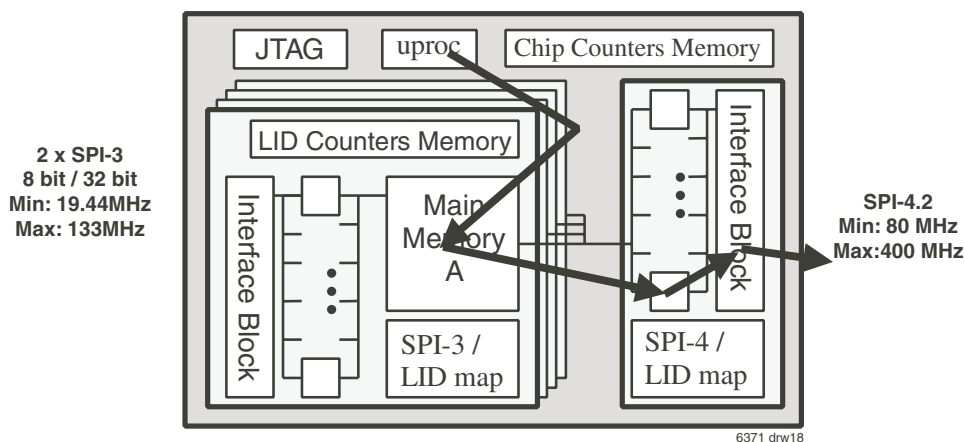

Figure 27. Microprocessor data insert interface to SPI-4 egress datapath

4.4.4 SPI-4 ingress to microprocessor interface datapath

The diagram below shows the datapath through the device from the SPI-4 interface to the microprocessor data capture interface.

The following is a description of the path taken by a burst of data through the device.

Data enters on the SPI-4 interface in bursts. Bursts are normally of equal length except the last burst of a packet which may be shorter. The control word is in-band with the data. The burst data enters a SPI-4 ingress buffer. SPI-4 LP

address, error information, SOP, and EOP are stored along with the burst data. The SPI-4 LP address is mapped to a LID. Data is stored in per-LID allocated buffer segments. The DIRECTION field of the SPI-3 egress port descriptor (Block_base 0x1700 + Register_offset 0x00 - 0xFF) is used to send this LID data to the microprocessor port. Data is moved to the capture buffer along with the LP address, LID, error information, SOP, and EOP.

The data available bit is set by the PFP. Data and control information are read from the capture buffer through the microprocessor interface.

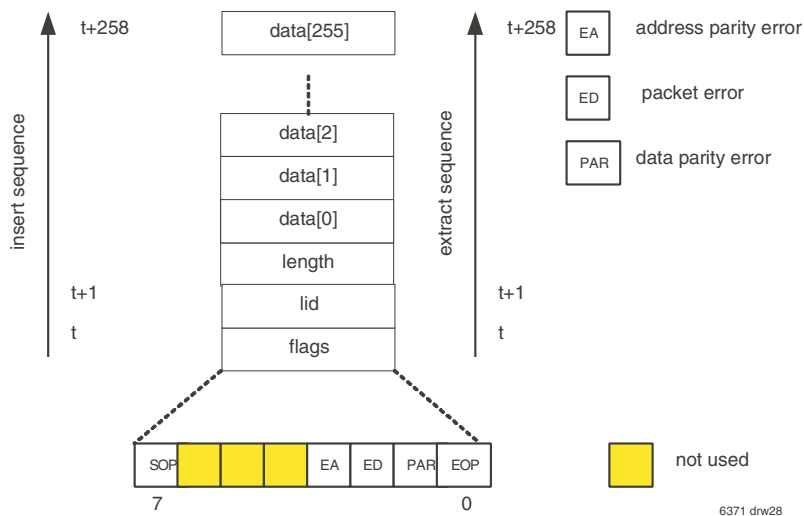

Figure 28. Microprocessor data capture buffer

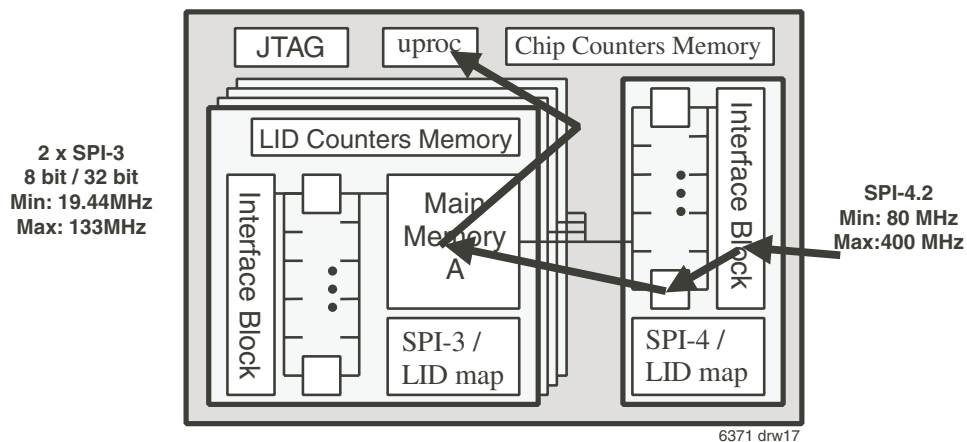

Figure 29. SPI-4 ingress to microprocessor data capture interface path

5. PERFORMANCE MONITOR AND DIAGNOSTICS

5.1 Mode of operation

A performance monitor & diagnostics module is available in modules A and B. The performance monitor captures events and accumulates error events and diagnostics data. Some performance monitor accumulators are associated to a physical port, some to a LID.

5.2 Counters

All events and diagnostics data are accumulated during an interval defined by the timebase event. The data accumulated during the previous time period can be accessed by the indirect access scheme. The counters are cleared when the timebase expires. All counters are saturating, and will not overflow.

5.2.1 LID associated event counters

A set of event counters is provided for each of the 64 LPs on each SPI-3 interface and for each LID to/from the SPI-4 module.

A packet is delineated by an SOP and EOP on the SPI-3/SPI-4 logical port. It is defined as "bad" when the packet is tagged with an error.

All packets that are not "bad" are considered "good".

For more information refer to Table 60 - LID Associated Event Counters (0x000-0x17F).

5.2.2 Non - LID associated event counters

A set of event counters is provided for each of the SPI-3 and SPI-4 physical interfaces.

Refer to Table 61, Non LID associated event counters (0x00-0x0B) for the offset in the indirect access space, and for the events recorded.

5.3 Captured events

Two categories of events are captured: LID and non LID associated events. If at least one event is captured in one of the interrupt indication registers, an active PMON service request is directed towards the interrupt module.

5.3.1 Non LID associated events

Non LID associated events are captured into the Table 62 - Non LID associated interrupt indication register (Block_base 0x0C00 + Register_offset 0x00 to 0x0B). An interrupt is generated if the event is enabled by its enable flag in the Table 63 - Non LID associated interrupt enable register (Block_base 0x0C00 + Register_offset 0x0D). The interrupt is cleared by writing a logical one to the Table 62 - Non LID associated interrupt indication register (Block_base 0x0C00 + Register_offset 0x00 to 0x0B).

5.3.2 LID associated events

Two types of LID associated events are captured. Non critical events are defined in Table 64 - LID-associated interrupt indication register (0x0E) and are associated with the physical interface. Critical events are defined as buffer overflows within the IDT88P8342 device in Table 67, SPI-3 to SPI-4 critical LID interrupt indication registers (register_offset 0x16-0x17).

5.3.2.1 Non critical events

LID associated non critical events are captured in the Table 64, LID-associated interrupt indication register (0x0E). An interrupt is generated if the interrupt is enabled by its enable flag in the Table 65, LID-associated interrupt enable register (0x0F). The interrupt indication is cleared by writing a logical one to the Table 64, LID-Associated Interrupt Indication Register (0x0E).

When the event is captured, the LID or LP associated with the event is captured in Table 66, Non-Critical LID-Associated Capture Table (0x10-0x15). The table records the latest captured LID or LP.

5.3.2.2 Critical events

Critical events are captured per LID in Table 67, SPI-3 to SPI-4 Critical LID interrupt indication registers (Block_base 0x0C00 + Register_offset 0x16-0x17) and Table 69, SPI-4 to SPI-3 critical LID interrupt indication registers (0x1A-0x1B). An interrupt is generated if enabled by the corresponding enable flag in the Table 68, SPI-3 to SPI-4 critical LID interrupt enable registers (0x18-0x19) and Table 70, SPI-4 to SPI-3 critical LID interrupt enable registers (0x1C-0x1D). The indication is cleared by writing a logical one to the Table 67, SPI-3 to SPI-4 critical LID interrupt indication registers (0x16-0x17) or Table 69, SPI-4 to SPI-3 critical LID interrupt indication registers (0x1A-0x1B). Only one kind of critical event is defined, buffer overflow. Since there are $64 \times 2 = 128$ critical LID associated event sources, two source indication bits are contained in Table 71, Critical events source indication register (0x1E). The bits are read only. Bit SPI34_OVR reflects the OR result of all bits in Table 67, SPI-3 to SPI-4 critical LID interrupt indication registers (0x16-0x17). Bit SPI43_OVR reflects the OR result of all bits in Table 69, SPI-4 to SPI-3 critical LID interrupt indication registers (0x1A-0x1B).

5.3.3 Timebase

A single timebase module is provided in the device. The timebase period can be configured to be internally or externally generated. A snapshot of the counters is taken when the timebase expires and the counters are cleared. The snapshot registers are accessed by an indirect access scheme.

5.3.3.1 Internally generated timebase

The period of the timebase is configured for the device using the register defined in Table 120, Timebase register (Register_offset 0x01). The configuration specifies the number of master clock (MCLK) cycles required for each period. For a description of MCLK refer to Chapter 6 Clock generator. The timebase event is captured by the timebase status in Table 45, Secondary interrupt status register (0x2D in the direct accessed space).

The internal timebase is generated either by the microprocessor or by a free running timer input. The selection is made by the TIMER flag in the Table 119, PMON update control register (Register_offset 0x00). When the time interval expires, the TIMEBASE pin is asserted for sixteen MCLK cycles.

5.3.3.2 Externally generated timebase

The externally generated timebase signal is applied on the TIMEBASE pin. A positive edge detector generates the timebase event. The timebase event is captured by the timebase status in the Table 45 - Secondary Interrupt Status Register (0x2D in the direct accessed space).

6. CLOCK GENERATOR

The device generates clocks from the SPI-4 ingress clock (I_DCLK) or from the REF_CLK input pin. The clock so selected is used for core functions of the device, and must be present during reset and thereafter. The selection and frequency divisors are defined by CK_SEL[3:0] pins as defined in the following Table 14, CK_SEL[3:0] input pin encoding.

The clock generator provides four clock outputs on the OCLK[3:0] pins, MCLK for internal use, and SPI-4 data and FIFO status channel egress clocks. The OCLK[3:0] clock frequencies can be selected independently of each other. OCLK[3:0] outputs always have a relative output skew of one pll_ock (refer to Figure 30 Clock generator) to prevent simultaneous switching when used as SPI-3 clock sources. Use of the OCLK[3:0] outputs is encouraged for the SPI-3 clock inputs to reduce system jitter. The frequency is divided according to the value selected in the clock generator control register shown below. The

OCLK[3:0] pins are separately enabled by setting each associated enable flag in Table 121, Clock generator control register (Register_offset 0x10). When an OCLK[3:0] output is not enabled, it is in a logic low state. MCLK is the internal processing clock, and is always enabled. Divide options should be selected to keep the internal PLL output pll_ock within its operating frequency range of 400 to 800 MHz. Refer to Table 122, OCLK and MCLK frequency select encoding for selecting the frequencies of MCLK and OCLKs. Note that divider values should be chosen so that OCLK[3:0] and MCLK are within their specified operating range provided in Table 136, OCLK[3:0] clock outputs and MCLK internal clock.

During either a hardware or a software reset, the OCLK[3:0] pins are all logic low. Immediately following reset, all OCLK[3:0] outputs are active with the output frequency defined by pll_ock divided by the initial value in the Table 121, Clock generator control register (Register_offset 0x10).

TABLE 14 – CK_SEL[3:0] INPUT PIN ENCODING

CK_SEL[1:0]	Function
00	pll_rclk = REF_CLK
01	pll_rclk = I_DCLK/16
10	pll_rclk = I_DCLK/8
11	pll_rclk = I_DCLK/4
CK_SEL[3:2]	Function
00	E_DCLK = pll_ock/2
01	E_DCLK = pll_ock/4
10	E_DCLK = pll_ock/6
11	E_DCLK = pll_ock/8

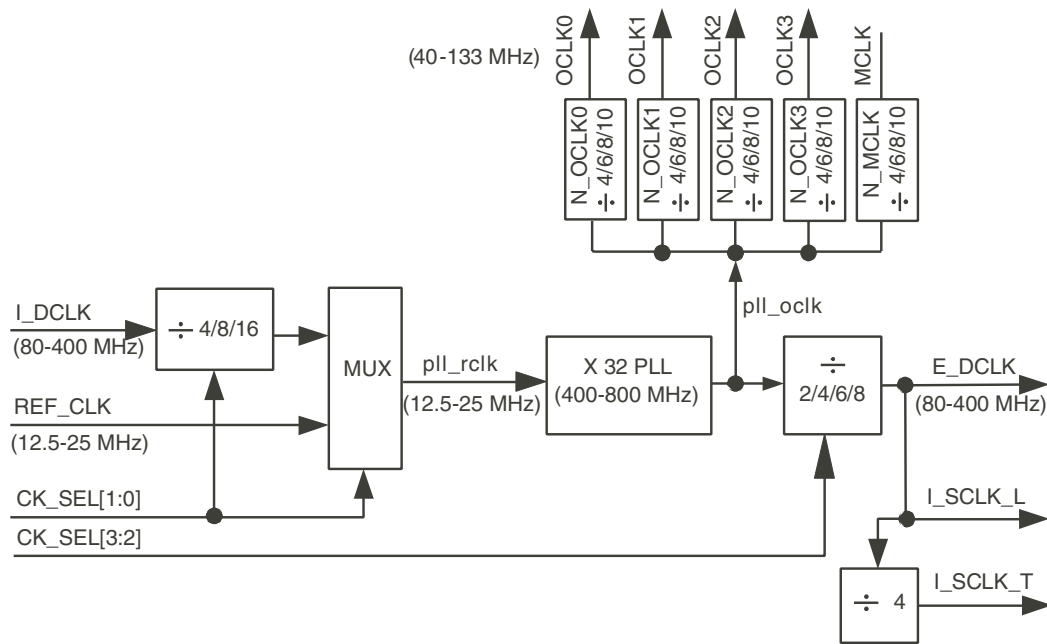

6370 drw21

Figure 30. Clock generator

7. LOOPBACKS

Local loopbacks are supported on both of the SPI-3 physical ports. They are described below.

7.1 SPI-3 Loopback

A SPI-3 physical port loop back is supported on both of the SPI-3 interfaces. In this mode, the contents of the SPI-3 ingress buffers are directly transferred to the SPI-3 egress buffers. All data and error information received on an ingress interface of a SPI-3 physical port is transmitted on the egress interface of the same SPI-3 physical port.

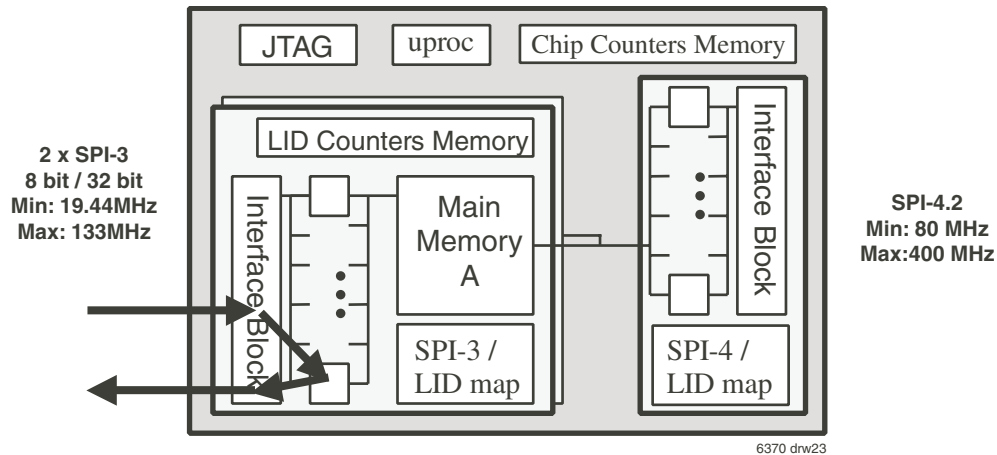

Figure 31. SPI-3 Loopback diagram

8. OPERATION GUIDE

8.1 Hardware operation

8.1.1 System reset

There are two methods for resetting the device: hardware reset & software reset. During reset the output clocks are not toggled.

Hardware reset

The RESETB input requires an active low pulse to reset the internal logic.

Software reset

The software reset is triggered by setting to 1 the SW_RESET field in direct register Software Reset Register (p.51). The response to a software reset is identical to a hardware reset except that software reset does not change the N_OCLK[3:0] fields in the Clock Generator Control Register (p.77), so it does not impact the clock generators. The SW_RESET field is self-clear to 0 after the device initialized itself. After software reset the external microprocessor should have delay of at least 1ms before accessing the device, and then. After the 1ms delay, the user should poll the INIT_DONE field in the Software Reset Register (p.51), and wait till it is 1. When the INIT_DONE field is 1, the user should download a boot code from the external microprocessor flash to the device embedded processor RAM.

8.1.2 Power on sequence

A correct power-on-reset sequence is crucial for the normal behavior of the device. The power-on-reset sequence includes the following signals:

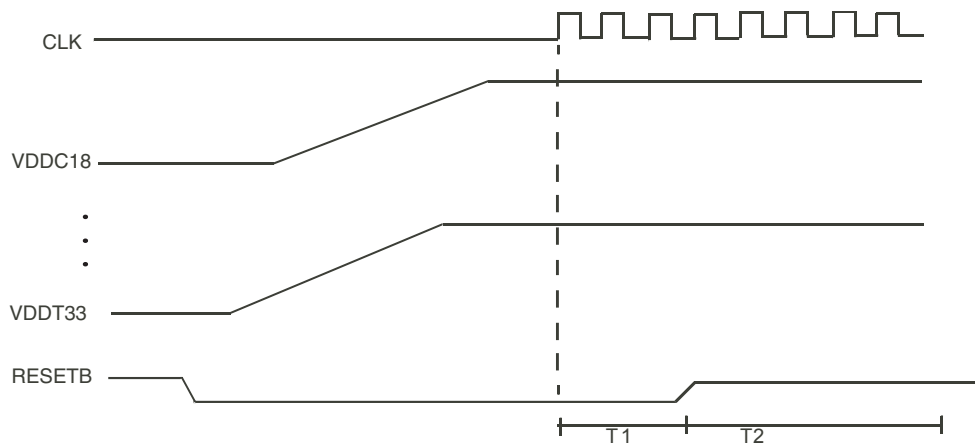

6371 drw23a

Figure 32. Power-on-Reset Sequence

8.1.3 Clock domains

The chip has several clock domains. The related registers can not be configured without each clock. It is necessary to supply the clocks that are pertinent to the registers being initialized for the initialization to succeed. In order to access the microprocessor interface, MCLK must be active, either by selecting and providing a stable REF_CLK input, or by selecting and ensuring that a stable clock is always present on the I_DCLK input. The selection of either the REF_CLK or the I_DCLK clock inputs is described in Table 14 CK_SEL[3:0] input pin decoding.

CLK (REF_CLK or I_DCLK - depends on which of these pins are selected), VDDT33, VDDC12 and RESETB. Figure 32, Power-on-Reset Sequence illustrates the recommended implementation for the power-on-reset sequence for the device. IDT recommends powering up the VDD33 power supply first, and the VDDC18 power supply last. The power supplies can be also powered up in the same time. There is no requirement for the minimum or maximum delay between the power-up of the power supplies. The power supplies should be powered off in the reverse order. The power ramp should not be fast than 100us, but also not too slow.

When the power supplies are powered up, the RESETB signal should be at low level. During power-on-reset, after the VDDT33, VDDC18, CLK (REF_CLK or I_DCLK - depends on which of these pins are selected) and the configuration signals are stable, the RESETB signal should remain at a low level at least 10ms (symbol "T1") to reset the internal logic. After the RESETB pulse ends, the device starts generating the SPI-4 / SPI-3 external output clocks & the MCLK internal clock.

After the RESETB pulse ends, a delay of 1ms should be added (symbols "T2") before accessing the device for initialization and configuration. This allows the internal logic to be stable. During T2 (at least 1ms delay) the device performs internal memories initialization.

After T2, the user should poll the INIT_DONE field in the in the Software Reset Register (p.51), and wait till it is 1. When the INIT_DONE field is 1, the user should download a boot code from the external microprocessor flash to the device embedded processor RAM.

8.2 Software operation

8.2.1 Chip configuration sequence

For proper device operation, it is important to initialize the IDT88P8342 in the correct sequence following reset. This sequence is outlined in the following paragraphs.

1) Reset the IDT88P8342 chip. After reset, the chip will perform auto initialization. Wait for the chip initialization to complete. The INIT_DONE flag will go high when initialization has been completed.

- 2) Configure the clock generator as follows:
 - a) Configure the value for the MCLK divider, OCLK dividers and enables in the Clock Generator Control Register (refer to Table 121, Clock generator control register (Register_offset 0x10)).
 - b) Configure the values for I_LOW and E_LOW (refer to Table 89, SPI-4 ingress configuration register (0x00) and Table 104, SPI-4 egress configuration register_0 (Register_offset 0x00)).
 - 3) Load status channel firmware. See section 8.2.5 for details.
 - 4) Configure all PFPs as follows:
 - a) The NR_LID fields must be configured first. Do not change the NR_LID fields once configured after reset. The NR_LID fields are in the Table 76, SPI-3 to SPI-4 PFP register (register_offset 0x00) and the Table 83, SPI-4 to SPI-3 PFP register (0x00).
 - b) There are four sets of port descriptor tables: The Table 73, SPI-4 egress port descriptor table (64 entries), the Table 75, SPI-3 ingress port descriptor table (Block_base 0x1200), the Table 80, SPI-3 egress port descriptor table (64 entries), and the Table 82, SPI-4 ingress port descriptor tables (64 entries). Configure the M (SPI-4 egress), MAX_BURST_S, MAX_BURST_H, DIRECTION (SPI-4 egress), FREE_SEGMENT, MAX_BURST, DIRECTION (SPI-3 egress), M (SPI-4 ingress), FREE_SEGMENT_S, and FREE_SEGMENT_H parameters of the port descriptor tables for each LID to be activated. The total buffer segment assignment should not exceed the available buffer segment pool capacity of 508 segments per PFP.
 - 5) Configure the Table 54 - SPI-3 egress LID to LP map.
 - 6) Configure the Table 49 - SPI-3 ingress LP to LID map.
 - 7) The SPI-4 Calendar tables must be configured before the SPI-4 mapping tables are configured. Do not change the SPI-4 calendar tables once they are configured. In LVDS status mode, ensure that the value of $(CAL_LEN+1) * (M+1)$ is at least 4.
 - a) Configure the SPI-4 ingress calendar or calendars (refer to Table 87, SPI-4 ingress calendar_0 (256 entries) and Table 88, SPI-4 ingress calendar_1 (256 entries)).
 - b) Configure the SPI-4 egress calendar or calendars (refer to Table 102, SPI-4 egress calendar_0 (256 locations) and Table 103, SPI-4 egress calendar_1 (256 locations)).
 - 8) Configure the Table 101, SPI-4 egress LID to LP map (256 entries).
 - 9) Configure the Table 86, SPI-4 ingress LP to LID (256 entries, one per LP).
 - 10) Configure the SPI-4 physical interface. The Table 89, SPI-4 ingress configuration register (0x00), Table 104, SPI-4 egress configuration register_0 (Register_offset 0x00), and Table 105, SPI-4 egress configuration register_1 (Register_offset 0x01) must be configured before enabling the SPI-4 physical interface. Once the SPI-4 interface is enabled, the SPI-4 interface configuration registers can not be changed unless the chip is reset. Individual LIDs can still be enabled or disabled, within the bounds set by NR_LID.
 - 11) Configure the SPI-3 physical interfaces. The Table 75, SPI-3 ingress port descriptor table (Block_base 0x1200) must be configured before enabling the SPI-3 physical interfaces. Once the SPI-3 interfaces are enabled, Table 80, SPI-3 egress port descriptor table (64 entries) can not be changed unless the chip is reset. Individual LIDs can still be enabled or disabled without a chip reset, within the bounds set by NR_LID.
 - 12) Enable the SPI-3 physical interfaces. Set the enable bit per LID in Table 50, SPI-3 ingress LP to LID map and Table 54, SPI-3 egress LID to LP map.
 - 13) Enable the SPI-4 physical interface. Set the enable bit per LID in Table 82, SPI-4 ingress LP to LID map (256 entries, one per LP) and Table 101, SPI-4 egress LID to LP map (256 entries).
- Note: Sufficient edge transitions on the bus are required to cause a change

in the TAP value. Therefore, the adjacent device should send training for at least 100ms in the end of the initialization sequence & before starting to send data. The bit alignment will select the best tap for each lane.

8.2.2 Logical Port activation and deactivation

Dynamically deactivate a logical port

The procedure for deactivating a logical port is outlined as follows:

- 1) Configure the enable bit of the ingress LP to LID map to "disabled".
- 2) Configure the egress data DIRECTION field in Table 73, SPI-4 egress port descriptor table (64 entries) or Table 80, SPI-3 egress port descriptor table (64 entries) to "discard".
- 3) Wait at least 0.1ms for the flush of the remaining data in the queue.
- 4) Change M to 0 for the LP.

Dynamically activate a logical port

The procedure for activating a logical port is outlined as follows:

- 1) Make sure the LID is inactive.
- 2) Configure M for the desired LID.
- 3) Configure the egress LID to LP map, then enable the LID.
- 4) Configure the egress data direction for the LID.
- 5) Configure the ingress LP to LID map, then enable the LP.

8.2.3 Buffer segment modification

Modification of the buffer segment allocation for a LID

The buffer segment allocation can be changed while the corresponding LP is disabled. The amount of buffering available for a LID can be decreased or it can be increased if more buffer segments are available for use. The procedure for changing the buffer segment allocation for a LID is outlined as follows:

- 1) Disable the LP corresponding to the LID to undergo buffer segment modification.
- 2) Discard the fragments, by configuring the DIRECTION field for DISCARD for the LID.
- 3) Wait at least 0.1ms for the buffer to empty.
- 4) Change M to 0 for the LID.
- 5) Configure the new M value for the LID.
- 6) Configure the DIRECTION field for the LID to restore data flow.
- 7) Enable the LP corresponding to the LID that underwent buffer segment modification.

8.2.4 Manual SPI-4 ingress LVDS bit alignment

The procedure for manually adjusting the SPI-4 ingress LVDS bit alignment is outlined. It is recommended to use automatic alignment in most cases.

- 1) Configure the FORCE bit from Table 99, SPI-4 ingress bit alignment control register (register_offset 0x11). This puts the SPI-4 ingress under manual control.
- 2) Configure the SPI-4 ingress data lane to be measured for clock-data alignment in Table 111, SPI-4 ingress lane measure register (register_offset 0x01), LANE field.
- 3) Wait for the eye measurement to complete in Table 111, SPI-4 ingress lane measure register (register_offset 0x01), MEASURE_busy field.
- 4) Read the eye pattern counter in Table 112, SPI-4 ingress bit alignment counter register (0x02 to 0x0B).
- 5) Calculate the proper value.
- 6) Configure the appropriate phase tap in Table 113, SPI-4 ingress manual alignment phase/result register (0x0C to 0x1F).

8.2.5 SPI-4 status channel software

The SPI-4 status channel may be configured to either TTL or LVDS by loading the appropriate status channel binary file to activate the firmware. Download LVTTTL.bin when using LVTTTL status mode. Download LVDS.bin when using LVDS status mode.

The download process is described.

```
Direct write (0x20, 0x01); /* Write register 0x20 with 0x01 to reset */
Delay at least 5ms
Direct write (0x36, 0x07);
ind_write(0x700c8, 0xdc0);
```

Open LVTTTL.bin or LVDS.bin file

```
number = file length
addr = 0x70e00;
if (number % 2 == 0)
    number /= 2;
else
    number = number/2 + 1;

for (i = 0; i < number; i++)
{
    scr_fp.Read(ch, 2);
    data = (ch[1] << 8) | ch[0];
    ind_write(addr, data);
    addr++;
}
close file
ind_write(0x700c6, 0x0e00);
ind_write(0x700c8, 0xc860);
Direct write (0x36, 0x00);
```

8.2.6 IDT88P8342 layout guidelines SPI-3 LAYOUT GUIDELINES

1) Series terminate SPI-3 traces that are greater than 1/2 inch in end-to-end length. Place the series resistor as close as possible to the driver, but no more than 1/2 inch away from the driving end. SPI-3 inputs must have ringing controlled to prevent the SPI-3 inputs from going more than 0.5 Volts below ground. Use the IBIS models for more accurate results with the specific devices being used.

2) Minimize all SPI-3 data and control trace lengths to not exceed the $T_{D-MAX} - T_{SETUP}$ requirement. For example, if the SPI-3 clock is 104 MHz, T_{D-MAX} of a device is 5.65 ns, and T_{SETUP} of the attached device is 1 ns, the maximum

PCB trace delay Table 18 permitted is 3 ns ($Unit\ Interval - T_{D-MAX} - T_{SETUP}$). This translates to a maximum PCB trace length for data and control lanes of 13.5 inches, if the loaded PCB trace delay is 220 picoseconds per inch. This is for zero T_{SETUP} margin, and does not include any margin for clock driver skew. Clock driver or clock trace skew could reduce the T_{SETUP} margin in this example.

3) Match all SPI-3 clock lengths to within the $T_{D-MIN} - T_{HOLD}$ requirement. For example, if T_{D-MIN} for the device is 1.5 ns, and T_{HOLD} for the attached device is 0.5 ns, the worst case PCB clock trace skew for zero T_{HOLD} margin (defined in this example as the maximum PCB trace delay that the SPI-3 ingress clock of the attached device can exceed the trace delay of the SPI-3 egress clock of the device and still meet the T_{HOLD} requirement of the attached device with zero margin, assuming the fastest device [T_{D-MIN}] and the worst case T_{HOLD} for the attached device and no trace delay on the data and control lanes) is 1.7 ns (Table 15 ($T_{D-MIN} - T_{HOLD}$)), for a maximum PCB clock trace difference of 7.6 inches. Trace delay on the data and control lanes would improve the T_{HOLD} margin in this example. This example does not include any margin for SPI-3 clock buffer skew.

4) Ensure a few nanoseconds of clock delay between one SPI-3 clock net and other SPI-3 clock nets of the same frequency to minimize simultaneous switching noise. The IDT88P8342 OCLK[3:0] outputs have skew between each output already built in, and so are useful in lowering simultaneous switching noise. A SPI-3 clock net is defined to be the SPI-3 egress clock for a device and the SPI-3 ingress clock for the attached device.

5) Route all SPI-3 traces as 50 Ohm embedded stripline (inner layer referencing ground planes). For example, 8 mil wide 1/2 oz copper traces sandwiched between ground planes with 10 mil dielectric spacing between ground planes and signal planes yields 52 Ohms single-ended, using FR-4 with a relative dielectric constant (ϵ_r or D_k) of 4.2. If the edge to edge spacing between adjacent SPI-3 series terminated signals is 20 mils in this example, crosstalk between adjacent signals can be kept to 2%. Use a field solver for more accurate results.

An example timing budget Table 15, Zero Margin SPI-3 Timing budget, and example trace lengths to achieve timing margin Table 16, Margin check for SPI-3 timing, are shown. These timing budget tables do not include clock driver relative skew incurred if different drivers are used for a SPI-3 egress and its attached SP-3 ingress. These tables are based on timing only and do not include such effects as crosstalk and rise time degradation.

SPI-4 LAYOUT GUIDELINES

1) Match the P and N trace lengths within an LVDS differential signal pair to within 100 mils or less.

2) Match the group of all differential data, control, and clock signal lengths to within 1/2 unit interval (DDR), or less, of each other (1/4 clock period). For

TABLE 15 - ZERO MARGIN SPI-3 TIMING BUDGET

SPI-3Clock	Tsetup	Thold	Td, minimum	Td, maximum	Unit Interval	Maximum data trace delay	Maximum data trace length	Maximum clock skew	Maximum Clock Δ trace length
104 MHz	1 ns	0.65 ns	2.33 ns	5.65 ns	9.6 ns	3 ns	13.5 in	1.7 ns	7.6 in

TABLE 16 - MARGIN CHECK FOR SPI-3 TIMING

SPI-3Clock	Tsetup	Thold	Td, minimum	Td, maximum	Egress clock trace	Ingress clock trace	Longest data trace	Shortest data trace	Tsetup margin	Thold margin
104 MHz	1 ns	0.65 ns	2.33 ns	5.65 ns	4 inches	8 inches	6 inches	4 inches	2.33 ns	1.48 ns

example, a SPI-4 clock of 400MHz gives a data unit interval of 1.25ns, so match the lengths within the entire signal group to within 625 ps, or 3 inches.

3) Keep P and N signals within a differential pair on the same layer with the minimum trace spacing possible while still being able to get 100 ohms differential impedance (tightly edge-coupled pair routing).

4) Route all differential pairs as 100 Ohm embedded differential stripline (on an inner layer, referencing ground planes). For example, 7 mil wide 1/2 oz copper traces separated by 10 mils, with 10 mil dielectric spacing to ground planes above and below the traces gives 100 Ohms of differential impedance for FR-4 with a relative dielectric constant (ϵ_r or D_k) of 4.2. If the edge to edge spacing between adjacent differential pair traces is 20mils, crosstalk is 0.6% for signals terminated to within a 10% impedance match. If the edge to edge spacing between a differential pair and an LVTTTL signal is 30 mils within the parameters of this example, crosstalk is 0.8% (with the LVTTTL signals series terminated). Use a field solver for more accurate results.

5) Follow the SPI-3 layout guidelines for any routed SPI-4 LVTTTL status signals.

GENERAL LAYOUT GUIDELINES

1) Keep LVDS signals far from LVTTTL signals: at least three times the dielectric thickness to the reference plane (or three times the trace separation, whichever is greater) in separation width, to minimize the crosstalk contribution of noise on the LVDS signals from the noisy LVTTTL environment.

2) Separate signals of the same type by at least twice the dielectric thickness (or twice the trace separation, whichever is greater) to the reference plane to reduce crosstalk.

3) The reference planes must extend at least five times the dielectric thickness from either side of the trace and be unbroken.

4) Avoid changing layers on high-speed signals. On a layer change, signals should share the same reference (such as ground), connected by reference vias close to the signal vias for good current return. If a different reference plane (such as Vcc) must be used due to a signal layer change, good high-frequency 0.01 μ F ceramic capacitors must be used to connect the references together as close to the signal vias as possible to ensure good transmission line properties and current return.

5) Use of a low-jitter (100 picoseconds peak-peak maximum jitter) frequency source for REF_CLK is important. If I_DCLK is used instead of REF_CLK, ensure that I_DCLK is low in jitter and always available.

6) Keep the power decoupling capacitors as close as possible to the power pins, using at least 15 mil traces and double vias for reduced inductance where possible.

7) Distribute some large-valued capacitors around the board for low-frequency decoupling and to lower the power-supply impedance.

8) TRSTB (JTAG reset) must have a pull down resistor or be connected to RESETB for normal operation.

9) Filter the 1.8 Volt and 3.3 Volt analog power pins to isolate them from the noisy digital environment. Use ferrite beads and capacitors (Pi filters) for VDDA18_x and VDDA33.

10) Suppress non-functional inner layer pads.

8.2.7 Software Eye-Opening Check on SPI-4 Interface

Since the SPI-4 interface is a DDR interface, both rising and falling edges are used to update or sink data.

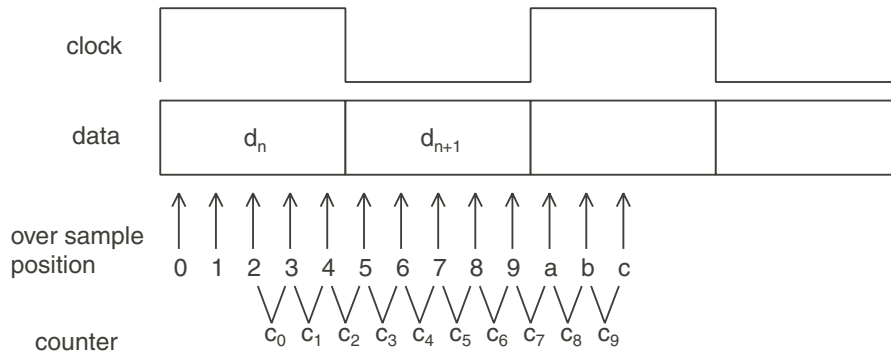

6371 drw23b

Figure 33. DDR interface and eye opening check through over sampling

Refer to the IDT88P8342 uses an internal sampling clock cycle which has a frequency of 10 times SPI-4 clock to over-sample the data on a lane. For each sampling clock cycle t position n data are sampled and labeled as $R_t.d_n$. The following operation is then performed:

$$\begin{aligned}
 CNT_0 &= R_t.d_2 \wedge R_{t+1}.d_3 \\
 CNT_1 &= R_t.d_3 \wedge R_{t+1}.d_4 \\
 CNT_2 &= R_t.d_4 \wedge R_{t+1}.d_5 \\
 CNT_3 &= R_t.d_5 \wedge R_{t+1}.d_6 \\
 CNT_4 &= R_t.d_6 \wedge R_{t+1}.d_7 \\
 CNT_5 &= R_t.d_7 \wedge R_{t+1}.d_8 \\
 CNT_6 &= R_t.d_8 \wedge R_{t+1}.d_9 \\
 CNT_7 &= R_t.d_9 \wedge R_{t+1}.d_0 \\
 CNT_8 &= R_t.d_0 \wedge R_{t+1}.d_1
 \end{aligned}$$

For an ideal case, there is zero jitter on clock and data, zero skew, the clock high and low level phase are symmetrical. For random input data on each lane, the counters $C_n = CNT_n(t) + CNT_n(t+1) + \dots + CNT_n(t+T)$, where T is a time window to do the statistics computation, will increment as follows:

Counter	C ₀	C ₁	C ₂	C ₃	C ₄	C ₅	C ₆	C ₇	C ₈	C ₉
Value	0	0	P	0	0	0	0	K	0	0

Where P and K are non-zero and need to be a large enough value mark the transition position of a clock and define the position.

Software for implementing the Eye-Opening Check

In the IDT88P8342, a set of diagnostic registers are provided for implementing an eye-opening check. The SPI-4 interface has 16 data lanes and one control lane on ingress, 2 status lanes on egress, making a total of 19 lanes.

The SPI-4 ingress bit alignment window register defines the window T stated above, based on which the signal statistics are computed. It is recommended to use the default value. The MEASURE_BUSY bit indicates the status of the internal measurement operation.

The SPI-4 ingress lane measure register selects the lane statistics counters to be read, a write to this register triggers the eye-opening check process to the

selected lanes and the MEASURE_BUSY bit will be set accordingly indicating the measuring process is active. The MEASURE_BUSY bit is cleared internally which indicates that the measuring process is complete. The measured result of counters C₀ through C₉ will be available in the SPI-4 ingress bit alignment counter registers.

Note that there is one SPI-4 ingress lane measure register and 19 SPI-4 ingress bit alignment counter registers.

The following pseudo code shows how to check the eye opening:

```
#define SPI-4_ingress_lane_measure_register 0x8801 /* register address in SPI exchange device*/
#define SPI-4_ingress_bit_alignment_counter_register(0) 0x8802
#define SPI-4_ingress_bit_alignment_counter_register(1) 0x8803
#define SPI-4_ingress_bit_alignment_counter_register(2) 0x8804
#define SPI-4_ingress_bit_alignment_counter_register(3) 0x8805
#define SPI-4_ingress_bit_alignment_counter_register(4) 0x8806
#define SPI-4_ingress_bit_alignment_counter_register(5) 0x8807
#define SPI-4_ingress_bit_alignment_counter_register(6) 0x8808
#define SPI-4_ingress_bit_alignment_counter_register(7) 0x8809
#define SPI-4_ingress_bit_alignment_counter_register(8) 0x880a
#define SPI-4_ingress_bit_alignment_counter_register(9) 0x880b

For lane=0 to K step 1 /*the number K depend on status mode: K=18 in LVDS status mode*/
{ /* K=16 otherwise */
    write #lane, SPI-4_ingress_lane_measure_register
    wait until BUSY=0 /* BUSY: bit 8 of SPI-4_ingress_lane_measure_register, at address
    0x8801*/
    for i=0 to 9 step 1
    {
        read C(i), SPI-4_ingress_bit_alignment_counter_register(i)
    }

    print C(0), C(1), C(2), C(3), C(4), C(5), C(6), C(7), C(8), C(9)
}
}
```

Because the SPI-4 ingress bit alignment counter register has a 10-bit width, the maximum counter value is 0x3ff.

If the counter values of a lane are:

0, 0, 0x3ff, 0, 0, 0, 0, 0x3ff, 0, 0

The eye open is perfect; there is very good signal integrity on input signals of the SPI-4 interface.

In each sample position represents a "tap". Depending on the delay in a lane, even a small jitter value of 1ps on the lane or the clock, may cause eye closing that can be detected by observing the counter values. In an ideal case with zero

delay, if the jitter on a data lane or clock is less than one tap interval (peak to peak), the jitter will not be reflected in counters. While the eye open check can indicate excessive jitter there are limitations in providing an accurate measurement using this method.

Theoretically as long as one tap accumulates enough non-zero samples for each 2 bits within a clock cycle the sampled signal position will be correct and the interface will function correctly. The more counters that have zero values, the better the eye opening.

9. REGISTER DESCRIPTION

There are two distinctly different types of register access in the IDT88P8342. Direct access registers are used for interrupts and other high-priority registers and for access to the indirect access registers. Direct access registers can be accessed more quickly than indirect access registers, and are used where this access speed advantage is required. There are only a limited number of direct access registers due to the six address lines used on the IDT88P8342. All direct access registers are one byte wide. Most registers within the IDT88P8342 are of the indirect access type. Indirect access registers are used for configuration, maps, etc., that may not need to be accessed as often as the direct registers.

Indirect registers are accessed through special direct access registers designed for the purpose of allowing indirect access to the large set of registers and maps that are needed to configure the IDT88P8342.

9.1 Register access summary

The SPI Exchange device uses an indirect addressing scheme for most of the configuration registers. The indirect registers are accessed through a protocol where interface pins A[5:0], D[7:0], and control pins are mapped into internal register space A[15:0], D[31:0], and Control[7:0]. The full address of any indirectly addressed register = Module_base + Block_base + Register_offset.

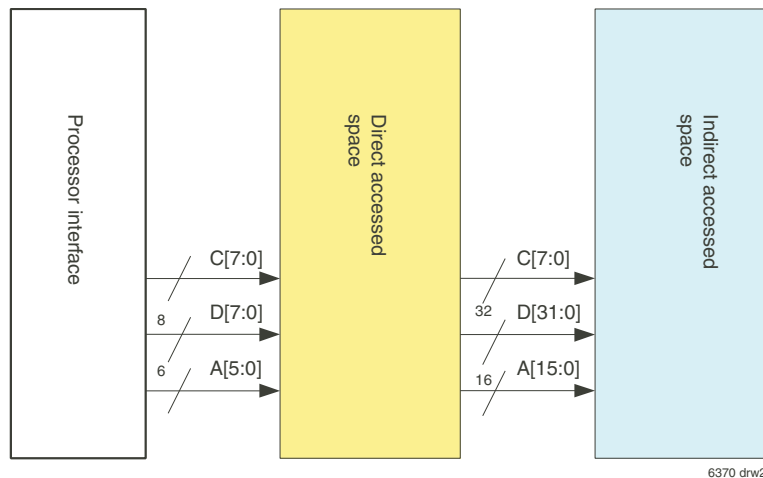

Figure 34. Direct & indirect access

9.1.1 Direct register format

All direct register accesses are one byte. The bit ordering for the direct access registers is shown.

TABLE 17 - BIT ORDER WITHIN AN 8-BIT DATA REGISTER

Direct Register Format
bit 7 bit 6 bit 5 bit 4 bit 3 bit 2 bit 1 bit 0

Bit 7 is the most significant data bit.

9.1.2 Indirect register format

The internal format for 32 and 8 bit registers is shown below. The registers are accessed from the external processor interface as successive bytes of indirect data. The indirect register space includes 32-bit data registers and 8-bit data registers. The directly-addressed register space includes directly-addressable 8-bit data registers, four 8-bit data registers for indirect data access, two 8-bit address registers for indirect data access, and an 8-bit control register for indirect data access.

TABLE 18 - BIT ORDER WITHIN A 32-BIT DATA REGISTER

Indirect Data (register 0x33)	Indirect Data (register 0x32)	Indirect Data (register 0x31)	Indirect Data (register 0x30)
bit 31...bit 25	bit 24...bit 16	bit 15...bit 8	bit 7...bit 0

Bit 31 is the most significant data bit.

TABLE 19 - BIT ORDER WITHIN AN 8-BIT DATA REGISTER

Indirect Data (register 0x30)
bit 7 bit 6 bit 5 bit 4 bit 3 bit 2 bit 1 bit 0

Bit 7 is the most significant data bit.

TABLE 20 - BIT ORDER WITHIN A 16-BIT ADDRESS REGISTER

Indirect High Address (register 0x35)	Indirect Low Address (register 0x34)
bit 15 bit 14 bit 13 bit 12 bit 11 bit 10 bit 9 bit 8	bit 7 bit 6 bit 5 bit 4 bit 3 bit 2 bit 1 bit 0

Bit 15 is the most significant data bit.

TABLE 21 - BIT ORDER WITHIN AN 8-BIT CONTROL REGISTER

Indirect Control (register 0x3F)
bit 7 bit 6 bit 5 bit 4 bit 3 bit 2 bit 1 bit 0

Bit 7 is the most significant data bit.

Module base address (Module_base)

There are three modules defined for indirect data access.

TABLE 22 - MODULE BASE ADDRESS (MODULE_BASE)

MODULE	Module_base
Module A (SPI3-A, PFP-A, PMON-A)	0x0000
Module B (SPI3-B, PFP-B, PMON-B)	0x2000
Common (SPI-4, timing, PMON, clock, GPIO, and version number)	0x8000

Block base

There are block bases defined for SPI-3 modules and also for Common, as shown in the following tables.

TABLE 23 - INDIRECT ACCESS BLOCK BASES FOR MODULE A AND MODULE B

Block_base	Function
0x0000	SPI-3 ingress LP to LID registers
0x0200	SPI-3 ingress general configuration register
0x0500	SPI-3 egress LID to LP registers
0x0700	SPI-3 egress configuration registers
0x0A00	LID associated event counters
0x0C00	Non LID associated event counters
0x1000	SPI-3 ingress packet length configuration register
0x1100	SPI-4 egress port descriptor table
0x1200	SPI-3 ingress port descriptor tables
0x1300	SPI-3 to SPI-4 PFP and flow control registers
0x1600	SPI-4 ingress control registers
0x1700	SPI-3 egress port descriptor table
0x1800	SPI-4 ingress port descriptor table
0x1900	SPI-4 to SPI-3 PFP register

TABLE 24 - INDIRECT ACCESS BLOCK BASES FOR COMMON MODULE

Block_base	Function
0x0000	SPI-4 ingress LP to LID tables
0x0100	SPI-4 ingress calendar_0
0x0200	SPI-4 ingress calendar_1
0x0300	SPI-4 ingress registers
0x0400	SPI-4 egress LID to LP map
0x0500	SPI-4 egress calendar_0
0x0600	SPI-4 egress calendar_1
0x0700	SPI-4 egress configuration and status registers
0x0800	SPI-4 ingress timing block registers
0x0900	PMON timebase control, clock generator control, GPIO register, and version number

Register offset

The register offset is shown in the section where the register is defined. The register offset is referred to as, "Register_offset", in this document. A register reference takes the form of, "[Register_offset 0xHH]", where HH is the hexadecimal value of the register offset.

Indirect register access**Indirect register write access**

An indirect write access is initiated by first checking for IND_BUSY=0 in the indirect access control register, and then writing data into the indirect access data registers. Next, the address is written into the indirect access address registers. Then, 0x00 is written into the indirect access control register. The status of the IND_BUSY flag in the indirect access control register is checked to ensure the process has completed before another indirect access can be initiated.

Indirect register read access

An indirect read access is initiated by first checking for IND_BUSY=0 in the indirect access control register, and then writing the address into the indirect access address registers. Then, 0x40 is written into the indirect access control register. The status of the IND_BUSY flag in the indirect access control register is checked to ensure the process has completed, and then data is read out from the indirect access data registers.

The registers for controlling indirect register access are shown below. The registers for controlling indirect register access are directly accessible with read and write access.

TABLE 25 - INDIRECT ACCESS DATA REGISTERS (DIRECT ACCESSED SPACE) AT 0x30 to 0x33

Field	Bits	Length	Function
DATA[7:0]	7:0	8	Indirect Data Register 0x30
DATA[15:8]	15:8	8	Indirect Data Register 0x31
DATA[23:16]	23:16	8	Indirect Data Register 0x32
DATA[31:24]	31:24	8	Indirect Data Register 0x33

TABLE 26 - INDIRECT ACCESS ADDRESS REGISTER (DIRECT ACCESSED SPACE) AT 0x34 to 0x35

Field	Bits	Length	Function
ADDRESS[7:0]	7:0	8	Indirect Low Address Register 0x34
ADDRESS[15:8]	15:8	8	Indirect High Address Register 0x35

TABLE 27 - INDIRECT ACCESS CONTROL REGISTER (DIRECT ACCESSED SPACE) AT 0x3F

Field	Bits	Length
ERROR code	5:0	6
RWN	6	1
IND_BUSY	7	1

The fields for this register are defined below.

ERROR code See Table 28, Error coding. This error code pertains to the last indirect access attempted.

TABLE 28 - ERROR CODING TABLE

ERROR code	Error Meaning
0x00	Normal indirect access completion
0x01	Multiple LP to same LID attempted assignment
0x02	Multiple LID to same LP attempted assignment
0x03	Buffer segment overflow
0x04	Not enough Queue entries
0x05	Attempt to modify while active
0x06	Address out of bound
0x07	Calibration before the chip has finished reset
0x08	LP limited
0x09	Undefined direction
0x3E	Undefined address
0x3F	Time out

R/WN This bit defines the read or write access to the indirect register.

0=WRITE

1=READ

IND_BUSY This bit is an indication of the ability of the indirect register access to accept a new transaction, and of the completion of the current transaction.

0=Ready for read or write operation

1=Busy indication. Wait before beginning a read or write operation

9.2 Direct access registers

The direct access registers are in the directly-addressed access space. Direct access registers are more quickly accessed, and serve the needs of interrupts and the indirect access registers.

TABLE 29 - DIRECT MAPPED MODULE A AND MODULE B REGISTERS

Module A and B direct registers	Module A	Module B
SPI-3 data capture control register	0x00	0x08
SPI-3 data capture register	0x01	0x09
SPI-4 data insert control register	0x02	0x0A
SPI-4 data insert register	0x03	0x0B
SPI-4 data capture control register	0x04	0x0C
SPI-3 data insert control register	0x05	0x0D
SPI-4 data capture register	0x06	0x0E
SPI-3 data insert register	0x07	0x0F
Module status register	0x24	0x25
Module enable register	0x28	0x29

TABLE 30 - DIRECT MAPPED OTHER REGISTERS

Other Direct registers	Address
Software reset	0x20
SPI-4 status register	0x22
SPI-4 enable register	0x23
Primary interrupt status register	0x2C
Secondary interrupt status register	0x2D
Primary interrupt enable register	0x2E
Secondary interrupt enable register	0x2F
Indirect access data[7:0]	0x30
Indirect access data[15:8]	0x31
Indirect access data[23:16]	0x32
Indirect access data[31:24]	0x33
Indirect access address[7:0]	0x34
Indirect access address[15:8]	0x35
Indirect access control[7:0]	0x3F

SPI-3 data capture control register

TABLE 31 - SPI-3 DATA CAPTURE CONTROL REGISTER (REGISTERS 0x00 and 0x08)

Field	Bits	Length	Initial Value
DATA_AVAILABLE	0	1	0b0
Reserved	7:1	7	0x00

A SPI-3 Data Capture Control Register has read and write access in the direct register access space. Write a zero to DATA_AVAILABLE to clear the transfer. The microprocessor uses these registers to capture data from a SPI-3 ingress.

The SPI-3 Data Capture Control Register for SPI-3 port A is register 0x00. The SPI-3 Data Capture Control Register for SPI-3 port B is register 0x08. The bit field of the SPI-3 Data Capture Control Register is described.

DATA_AVAILABLE The SPI-3 capture data buffer is full and ready for reading.

SPI-3 data capture register

TABLE 32 - SPI-3 DATA CAPTURE REGISTER (REGISTERS 0x01 and 0x09)

Field	Bits	Length	Initial Value
DATA	7:0	8	0x00

A SPI-3 Data Capture Register has read-only access in the direct register access space. The microprocessor uses these registers to capture data from a SPI-3 ingress.

The SPI-3 Data Capture Register for SPI-3 port A is register 0x01. The SPI-3 Data Capture Register for SPI-3 port B is register 0x09. The bit field of the SPI-3 Data Capture Register is described.

DATA The SPI-3 capture data buffer is read from this field.

SPI-4 data insert control register**TABLE 33 - SPI-4 DATA INSERT CONTROL REGISTER (REGISTERS 0x02 and 0x0A)**

Field	Bits	Length	Initial Value
DATA_AVAILABLE	0	1	0b0
Reserved	7:1	7	0x00

A SPI-4 data insert control register has read and write access in the direct register access space. The microprocessor uses these registers to insert data into a SPI-3 ingress.

The SPI-4 data insert control register for SPI-3 port A is register 0x02.

The SPI-4 data insert control register for SPI-3 port B is register 0x0A.

The bit field of the SPI-4 data insert control register is described.

DATA_AVAILABLE The SPI-4 insert data buffer is empty and ready for writing.

SPI-4 data insert register**TABLE 34 - SPI-4 DATA INSERT REGISTER (REGISTERS 0x03 and 0x0B)**

Field	Bits	Length	Initial Value
DATA	7:0	8	0x00

A SPI-4 data insert register has write-only access in the direct register access space. The microprocessor uses these registers to insert data into a SPI-3 ingress.

The SPI-4 Data Insert Register for SPI-3 port A is register 0x03.

The SPI-4 Data Insert Register for SPI-3 port B is register 0x0B.

The bit field of the SPI-4 Data Insert Register is described.

DATA The SPI-4 insert data buffer is written to this field.

SPI-4 data capture control register**TABLE 35 - SPI-4 DATA CAPTURE CONTROL REGISTERS (REGISTERS 0x04 and 0x0C)**

Field	Bits	Length	Initial Value
DATA_AVAILABLE	0	1	0b0
Reserved	7:1	7	0x00

A SPI-4 Data Capture Control Register has read and write access in the direct register access space. The microprocessor uses these registers to capture data from a SPI-3 ingress.

The SPI-4 Data Capture Control Register for SPI-3 port A is register 0x04.

The SPI-4 Data Capture Control Register for SPI-3 port B is register 0x0C.

The bit field of the SPI-4 Data Capture Control Register is described.

DATA_AVAILABLE The SPI-4 capture data buffer is full and ready for reading.

SPI-3 data insert control register**TABLE 36 - SPI-3 DATA INSERT CONTROL REGISTER (REGISTERS 0x05 and 0x0D)**

Field	Bits	Length	Initial Value
DATA_AVAILABLE	0	1	0b0
Reserved	7:1	7	0x00

A SPI-3 data insert control register has read and write access in the direct register access space. The microprocessor uses these registers to insert data into a SPI-4 ingress.

The SPI-3 Data Insert Control Register for SPI-3 port A is register 0x05.

The SPI-3 Data Insert Control Register for SPI-3 port B is register 0x0D.

The bit field of the SPI-3 Data Insert Control Register is described.

DATA_AVAILABLE The SPI-3 insert data buffer is empty and available for writing.

SPI-4 data capture register**TABLE 37 - SPI-4 DATA CAPTURE REGISTER (REGISTERS 0x06 and 0x0E)**

Field	Bits	Length	Initial Value
DATA	7:0	8	0x00

A SPI-4 data capture register has read-only access in the direct register access space. The microprocessor uses these registers to capture data from a SPI-4 ingress.

The SPI-4 Data Capture Register for SPI-3 port A is register 0x06.

The SPI-4 Data Capture Register for SPI-3 port B is register 0x0E.

The bit field of the SPI-4 Data Capture Register is described.

DATA The SPI-4 capture data buffer is read from this field.

SPI-3 data insert register**TABLE 38 - SPI-3 DATA INSERT REGISTER (REGISTERS 0x07 and 0x0F)**

Field	Bits	Length	Initial Value
DATA	7:0	8	0x00

A SPI-3 Data Insert Register has write-only access in the direct register access space. The microprocessor uses these registers to insert data into a SPI-4 ingress.

The SPI-3 Data Insert Register for SPI-3 port A is register 0x07.

The SPI-3 Data Insert Register for SPI-3 port B is register 0x0F.

The bit field of the SPI-3 Data Capture Register is described.

DATA The SPI-3 insert data buffer is written from this field.

Software reset

TABLE 39 - SOFTWARE RESET REGISTER (0x20 in the direct accessed space)

Field	Bits	Length	Initial Value
SW_RESET	0	1	0
INIT_DONE	1	1	0
Reserved	7:2	6	0

The software reset bit is writable from the direct accessed memory space. Write a "1" to the SW_RESET bit to initiate the software reset. The SW_RESET bit will clear to a "0" after the chip has initialized itself. The INIT_DONE bit is set to a "1" when the initialization following reset has completed. The software reset is the same as the hardware. The Reserved field must be set to 0.

The Initial Value column in this document is the value of the register after reset has completed.

SW_RESET Setting the SW_RESET bit initiates a software reset of the chip. The SW_RESET bit is self-clearing.
 0=No operation is performed
 1=Initiate a software reset

INIT_DONE Status indication bit following a reset.
 0=Chip has not completed initialization following reset
 1=Chip has completed initialization following reset

SPI-4 status register (0x22 in the direct accessed space)

TABLE 40 - SPI-4 STATUS REGISTER (0x22 IN THE DIRECT ACCESSED SPACE)

Field	Bits	Length	Initial Val
I_DIP_ERR_I	0	1	0
I_SYNCH_I	1	1	0
I_BUS_ERR_I	2	1	0
SPI4_INACTIVE_TRANSFER_I	3	1	0
DCLK_UN_I	4	1	0
E_DIP_ERR_I	5	1	0
E_SYNCH_I	6	1	0
SCLK_UN_I	7	1	0

The SPI-4 Status Register (0x22 in the direct accessed space) has read access, and interrupt status fields are cleared by a microprocessor write cycle, where a logical one must be written to clear the field(s) targeted.

The SPI-4 Status Register is a secondary interrupt status register and can only be active if the SPI-4 field is active in the Primary Interrupt Status Register (Direct 0x2C).

I_DIP_ERR_I SPI-4 ingress DIP-4 error interrupt indication.
 0=No errors
 1=One or more DIP-4 errors have been registered on the SPI-4 ingress

I_SYNCH_I SPI-4 ingress data path has transitioned from out of synchronization to in synchronization condition interrupt indication.
 0=No detection, still not in synchronization
 1=Transition from out of synchronization to in synchronization, or transition from in synchronization to out of synchronization.

I_BUS_ERR_I SPI-4 ingress bus error interrupt indication.
 0=No errors
 1=One or more bus errors have been registered on the SPI-4 ingress

SPI4_INACTIVE_TRANSFER_I SPI-4 ingress inactive transfer interrupt indication.
 0=No indication
 1=One or more inactive transfers have been registered on the SPI-4 ingress

DCLK_UN_I SPI-4 ingress data clock has transitioned from available to an unavailable condition interrupt indication.
 0=No detection, I_DCLK is available
 1=I_DCLK transitioned from available to an unavailable state

E_DIP_ERR_I SPI-4 egress DIP-2 error interrupt indication on the SPI-4 egress status channel.
 0=No errors
 1=One or more DIP-2 errors have been registered

E_SYNCH_I SPI-4 egress status channel has transitioned from out of synchronization to an in synchronization condition interrupt indication.
 0=No detection, still not in synchronization
 1=Transition from out of synchronization to in synchronization, or transition from in synchronization to out of synchronization.

SCLK_UN_I SPI-4 egress status clock has transitioned from available to an unavailable condition interrupt indication.
 In LVTTTL mode the Bridgeport does not detect the SPI-4 egress status clock (E_SCLK_T). Therefore, for LVTTTL mode the software should ignore the SCLK_UN field in the SPI-4 Status Register.
 0=No detection, E_SCLK is available
 1=E_SCLK transitioned from available to an unavailable state

SPI-4 enable register (0x23 in the direct accessed space)

TABLE 41 - SPI-4 ENABLE REGISTER (0x23 IN THE DIRECT ACCESSED SPACE)

Field	Bits	Length	Initial Val
I_DIP4_ERR_EN	0	1	0
I_SYNCH_EN	1	1	0
I_BUS_ERR_EN	2	1	0
SPI4_INACTIVE_TRANSFER_EN	3	1	0
DCLK_UN_EN	4	1	0
E_DIP_ERR_EN	5	1	0
E_SYNCH_EN	6	1	0
SCLK_UN_EN	7	1	0

The SPI-4 Enable Register (0x23 in the direct accessed space) has read and write access. SPI-4 Enable Register is used to bitwise enable the interrupts in the SPI-4 Status Register.

I_DIP4_ERR_EN SPI-4 ingress DIP-4 error interrupt indication enable.
 0=Disable DIP-4 error interrupt
 1=Enable DIP-4 error interrupt

I_SYNCH_EN SPI-4 ingress data path has transitioned from out of synchronization to in synchronization condition interrupt indication enable.
 0=Disable synchronization interrupt
 1=Enable synchronization interrupt

I_BUS_ERR_EN SPI-4 ingress bus error interrupt indication enable.
 0=Disable bus error interrupt
 1=Enable bus error interrupt

SPI4_INACTIVE_TRANSFER_EN SPI-4 ingress inactive transfer interrupt indication enable.
 0=Disable inactive transfer interrupt
 1=Enable inactive transfer interrupt

DCLK_UN_EN SPI-4 ingress data clock has transitioned from available to an unavailable condition interrupt indication enable.
 0=Disable unavailable interrupt
 1=Enable unavailable interrupt

E_DIP_ERR_EN SPI-4 egress DIP-2 error interrupt indication enable on the SPI-4 egress status channel.
 0=Disable DIP-2 error interrupt
 1=Enable DIP-2 error interrupt

E_SYNCH_EN SPI-4 egress status channel has transitioned from out of synchronization to in synchronization condition interrupt indication enable.
 0=Disable synchronization interrupt
 1=Enable synchronization interrupt

SCLK_UN_EN SPI-4 egress status clock has transitioned from available to an unavailable condition interrupt indication enable. SCLK_UN_EN should be written as a zero if using a SPI-4 egress LVTTTL status clock that is less than one-half of the MCLK frequency. The SCLK_UN_I interrupt indication is not usable in this case.
 0=Disable unavailable interrupt
 1=Enable unavailable interrupt

Module status register (0x24 and 0x25 in the direct accessed space)

TABLE 42 - MODULE STATUS REGISTER (0x24 AND 0x25 IN THE DIRECT ACCESSED SPACE)

Field	Bits	Length	Initial Value
SPI-34_CAPTURE	0	1	0
SPI-43_CAPTURE	1	1	0
SPI-34_INSERT	2	1	0
SPI-43_INSERT	3	1	0
PMON	4	1	0
Reserved	7:5	3	0

The Module Status registers (0x24 and 0x25 in the direct accessed space) have read and write access, and interrupt status fields are cleared by a microprocessor write cycle, where a logical one must be written to clear the field(s) targeted, except for the PMON field, which can not be cleared.

The Module Status registers are secondary interrupt status registers and can only be active if the corresponding field is active in the Primary Interrupt Status Register (Direct 0x2C):

Module Status Register 0x24 is for module A, and can only be active if the MODULE_A field is active in the Primary Interrupt Status Register.

Module Status Register 0x25 is for module B, and can only be active if the MODULE_B field is active in the Primary Interrupt Status Register.

SPI-34_CAPTURE SPI-3 ingress to SPI-4 egress capture event interrupt indication.
 0=No capture event
 1=Buffer is ready for reading by the microprocessor

SPI-43_CAPTURE SPI-4 ingress to SPI-3 egress capture event interrupt indication.
 0=No capture event
 1=Buffer is ready for reading by the microprocessor

SPI-34_INSERT SPI-3 ingress to SPI-4 egress insert event interrupt indication.
 0=No insert event
 1=Buffer is ready for writing by the microprocessor

SPI-43_INSERT SPI-4 ingress to SPI-3 egress insert event interrupt indication.
 0=No insert event
 1=Buffer is ready for writing by the microprocessor

PMON Performance Monitor event interrupt indication. Writing to this field has no effect.
 0=No PMON event
 1=PMON event is ready for reading by the microprocessor

Module enable register (0x28 and 0x29 in the direct accessed space)

TABLE 43 - MODULE ENABLE REGISTER (0x28 AND 0x29 IN THE DIRECT ACCESSED SPACE)

Field	Bits	Length	Initial Value
SPI-34_CAPTURE_EN	0	1	0
SPI-43_CAPTURE_EN	1	1	0
SPI-34_INSERT_EN	2	1	0
SPI-43_INSERT_EN	3	1	0
PMON_EN	4	1	0
Reserved	7:5	3	0

The Module Enable registers (0x28 and 0x29 in the direct accessed space) have read and write access.

Module Enable Register 0x28 is for module A.
 Module Enable Register 0x29 is for module B.

SPI-34_CAPTURE_EN SPI-3 ingress to SPI-4 egress capture event interrupt enable.
 0=Disable capture interrupt
 1=Enable capture interrupt

SPI-43_CAPTURE_EN SPI-4 ingress to SPI-3 egress capture event interrupt enable.
 0=Disable capture interrupt
 1=Enable capture interrupt

SPI-34_INSERT_EN SPI-3 ingress to SPI-4 egress insert event interrupt enable.
 0=Disable insert interrupt
 1=Enable insert interrupt

SPI-43_INSERT_EN SPI-4 ingress to SPI-3 egress insert event interrupt enable.
 0=Disable insert interrupt
 1=Enable insert interrupt

PMON_EN Performance Monitor event interrupt enable.
 0=Disable PMON interrupt
 1=Enable PMON interrupt

Primary interrupt status register (0x2C in the direct accessed space)

TABLE 44 - PRIMARY INTERRUPT STATUS REGISTER (0x2C IN THE DIRECT ACCESSED SPACE)

Field	Bits	Length	Initial Value
MODULE_A	0	1	0
MODULE_B	1	1	0
Reserved	2	1	0
Reserved	3	1	0
SPI-4	4	1	0
SECONDARY	5	1	0
Reserved	7:6	2	0

The primary interrupt status register (0x2C in the direct accessed space) has read-only access. The interrupts for the primary interrupt status register must be acknowledged by servicing the corresponding secondary interrupt status registers.

MODULE_A When active, the MODULE_A field is responsible for allowing an interrupt in the Module Status Register (secondary interrupt register 0x24).
 0=No MODULE_A interrupt active
 1=MODULE_A interrupt is active

MODULE_B When active, the MODULE_B field is responsible for allowing an interrupt in the module status register (secondary interrupt register 0x25).
 0=No MODULE_B interrupt active
 1=MODULE_B interrupt is active

SPI-4 When active, the SPI-4 field is responsible for allowing an interrupt in the SPI-4 status register (secondary interrupt register 0x22).
 0=No SPI-4 interrupt active
 1=SPI-4 interrupt is active

SECONDARY When active, the SECONDARY field is responsible for allowing an interrupt in the Secondary Interrupt Status Register (secondary interrupt register 0x2D).
 0=No SECONDARY interrupt active
 1=SECONDARY interrupt is active

Secondary interrupt status register (0x2D in the direct accessed space)

TABLE 45 - SECONDARY INTERRUPT STATUS REGISTER (0x2D IN THE DIRECT ACCESSED SPACE)

Field	Bits	Length	Initial Value
TIME_BASE	0	1	0
INDIRECT_ACCESS	1	1	0
Reserved	7:2	6	0

The secondary interrupt status register (0x2D in the direct accessed space) has read and write access.

The secondary interrupt status register has read access, and Interrupt status fields are cleared by a microprocessor write cycle, where a logical one must be written to clear the field(s) targeted.

The secondary interrupt status register is a secondary interrupt status register and can only be active if the SECONDARY_EN field is active in the primary interrupt enable register (Direct 0x2C).

TIME_BASE Time base expiration interrupt indication.
 0=No time base event
 1=Time base has expired

INDIRECT_ACCESS Indirect access completion interrupt indication.
 0=No indirect access event
 1=Indirect access has completed

Primary interrupt enable register (0x2E in the direct accessed space)

TABLE 46 - PRIMARY INTERRUPT ENABLE REGISTER (0x2E IN THE DIRECT ACCESSED SPACE)

Field	Bits	Length	Initial Value
MODULE_A_EN	0	1	0
MODULE_B_EN	1	1	0
Reserved	2	1	0
Reserved	3	1	0
SPI4_EN	4	1	0
SECONDARY_EN	5	1	0
Reserved	7:6	2	0

The primary interrupt enable register (0x2E in the direct accessed space) has read and write access.

The Primary Interrupt Enable Register is used to bitwise enable the interrupts in the Primary Interrupt Status Register.

MODULE_A_EN MODULE_A interrupt enable.
0=Disable MODULE_A interrupt
1=Enable MODULE_A interrupt

MODULE_B_EN MODULE_B interrupt enable.
0=Disable MODULE_B interrupt
1=Enable MODULE_B interrupt

SPI-4_EN SPI-4 interrupt enable.
0=Disable SPI-4 interrupt
1=Enable SPI-4 interrupt

SECONDARY_EN SECONDARY interrupt enable.
0=Disable SECONDARY interrupt
1=Enable SECONDARY interrupt

Secondary interrupt enable register (0x2F in the direct accessed space)

TABLE 47 - SECONDARY INTERRUPT ENABLE REGISTER (0x2F IN THE DIRECT ACCESSED SPACE)

Field	Bits	Length	Initial Value
TIME_BASE_EN	0	1	0
INDIRECT_ACCESS_EN	1	1	0
Reserved	7:2	6	0

The secondary interrupt enable register (0x2F in the direct accessed space) has read and write access.

The secondary interrupt enable register is used to bitwise enable the interrupts in the secondary interrupt enable register.

TIME_BASE_EN Time base expiration interrupt enable.
0=Disable time base event interrupt
1=Enable time base event interrupt

INDIRECT_ACCESS_EN Indirect access completion interrupt enable.
0=Disable indirect access completion event interrupt
1=Enable indirect access completion event interrupt

9.3 Indirect registers for SPI-3A and SPI-3B modules

Module A is at Module_base 0x0000

Module B is at Module_base 0x2000

TABLE 48 - MODULE A/B INDIRECT REGISTER

Table Number, Page	Block_base, Register_offset	Title of Register
49, page 57	0x0000, 0x00-0xFF	SPI-3 ingress LP to LID map
50, page 57	0x0200, 0x00	SPI-3 general configuration register
51, page 58	0x0200, 0x01	SPI-3 ingress configuration register
52, page 58	0x0200, 0x02	SPI-3 ingress fill level register
53, page 58	0x0200, 0x03	SPI-3 ingress max fill level register
54, page 58	0x0500, 0x00-0x3F	SPI-3 egress LID to LP map
55, page 59	0x0700, 0x00	SPI-3 egress configuration register
56, page 59	0x0700, 0x01	SPI-4 ingress to SPI-4 egress flow control register
57, page 59	0x0700, 0x02	SPI-3 egress test register
58, page 60	0x0700, 0x03	SPI-3 egress fill level register
59, page 60	0x0700, 0x04	SPI-3 egress max fill level register
60, page 61	0x0A00, 0x00-0x17F	LID associated event counters
61, page 61	0x0C00, 0x00-0x0B	Non LID associated event counters
62, page 62	0x0C00, 0x0C	Non LID associated interrupt indication register
63, page 62	0x0C00, 0x0D	Non LID associated interrupt enable register
64, page 62	0x0C00, 0x0E	LID associated interrupt indication register
65, page 62	0x0C00, 0x0F	LID associated interrupt enable register
66, page 63	0x0C00, 0x10-0x15	Non critical LID associated capture table
67, page 63	0x0C00, 0x16-0x17	SPI-3 to SPI-4 critical LID interrupt indication registers
68, page 63	0x0C00, 0x18-0x19	SPI-3 to SPI-4 critical LID interrupt enable registers
69, page 63	0x0C00, 0x1A-0x1B	SPI-4 to SPI-3 critical LID interrupt indication registers
70, page 63	0x0C00, 0x1C-0x1D	SPI-4 to SPI-3 critical LID interrupt enable registers
71, page 63	0x0C00, 0x1E	Critical events source indication register
72, page 64	0x1000, 0x00-0x3F	SPI-3 ingress packet length configuration register
73, page 64	0x1100, 0x00-0x3F	SPI-4 egress port descriptor table
74, page 64	-----	SPI-4 egress direction code assignment
75, page 64	0x1200, 0x00-0x3F	SPI-3 ingress port descriptor table
76, page 65	0x1300, 0x00	SPI-3 to SPI-4 PFP register
77, page 65	-----	NR_LID field encoding
78, page 65	0x1300, 0x01	SPI-3 to SPI-4 flow control register
79, page 66	0x1600, 0x00-0x3F	SPI-4 ingress packet length register
80, page 66	0x1700, 0x00-0x3F	SPI-3 egress port descriptor table
81, page 66	-----	SPI-3 egress direction code assignment
82, page 66	0x1800, 0x00-0x3F	SPI-4 ingress port descriptor table
83, page 67	0x1900, 0x00	SPI-4 to SPI-3 PFP register
84, page 67	-----	NR_LID field encoding

9.3.1 Block base 0x0000 registers

SPI-3 ingress LP to LID map (Block_base 0x0000 + Register_offset 0x00 to 0xFF)

TABLE 49 - SPI-3 INGRESS LP TO LID MAP

Field	Bits	Length	Initial Value
LID	5:0	6	0x00
ENABLE	6	1	0b0
BIT_REVERSAL	7	1	0b0

There are 256 SPI-3 ingress Logical Port (LP) to Logical Identifier (LID) registers, one per potential SPI-3 LP. Only 64 LPs per SPI-3 physical interface can be enabled. An attempt to enable more than 64 LPs per SPI-3 physical interface or to assign an identical LID to more than one LP will be discarded and an error code will be returned. The ENABLE bit is used to enable SPI-3 logical ports. All data from non-enabled SPI-3 logical ports is discarded and an inactive SPI-3 logical port event is generated. This event is directed towards the PMON & DIAG module. Disabled ports always generate available status.

The Table 49 - SPI-3 ingress LP to LID Map assigns a LID to a SPI-3 logical port. LID mapping for 64 out of 256 SPI-3 logical ports is supported on each SPI-3 physical port. LPs in the SPI Exchange are 8 bits wide[7:0] and range from 0 to 255. An example of mapping SPI-3 physical interface "A", LP 0x08 to LID 0x05, activating the LID, and not using bit reversal is outlined.

Perform an indirect write of 0x45 to register address Module_base 0x0000 + Block_base 0x0000 + Register_offset 0x08 = 0x0008. Another example of SPI-3 LP to LID mapping is to map SPI-3 "B", LP 0xFF to LID 0x3F, write 0x7F to register Module_base 0x2000 + Block_base 0x0000 + Register_offset 0xFF = 0x20FF.

The Initial Value column is the value of the register after reset.

LID The LID programmed is associated to the LP with the same number as the register address. Six bits support the 64 simultaneously active LIDs per SPI-3 physical interface.

ENABLE This bit is used to enable or disable the connection of this LP to this LID.

0=LID disabled
1=LID enabled

BIT_REVERSAL This bit is used to reverse the bit ordering of each byte of the SPI-3 interface on a per-LID basis.

0=Disable bit reversal for this LID
1=Enable bit reversal for this LID

9.3.2 Block base 0x0200 registers

SPI-3 general configuration register (Block_base 0x0200 + Register_offset 0x00)

TABLE 50 - SPI-3 GENERAL CONFIGURATION REGISTER (REGISTER_OFFSET=0x00)

Field	Bits	Length	Initial Value
LINK	0	1	0b0
PACKET	1	1	0b1
SPI3_ENABLE	2	1	0b0
BUSWIDTH	3	1	0b0
EVEN_PARITY	4	1	0b0
PARITY_EN	5	1	0b1
Reserved	6	1	0b0
Reserved	7	1	0b0
WATERMARK	12:8	5	0x0F
Reserved	31:13	19	0x000

There is one register for SPI-3 general configuration per SPI-3 interface. Each register has read and write access. The address for module A is 0x0200, and the address for module B is 0x2200. The bit fields of the SPI-3 general configuration register are described in the following paragraphs.

LINK A SPI-3 interface can be used either in Link or PHY modes. For connecting to a transmission line-interface PHY, program the SPI Exchange for Link mode. For connecting the SPI-3 interface to an NPU or other Link-mode device, program the SPI-3 interface for PHY mode. Note that the two SPI-3 interfaces can be independently configured into either Link or PHY modes. The SPI-3 ingress and egress of a given SPI-3 physical port will always be in the same mode.

0= SPI-3 interface in PHY mode
1= SPI-3 interface in Link mode

PACKET A SPI-3 interface can be used either in BYTE or PACKET modes. A SPI-3 interface acting as a Link layer device can poll the attached PHY device for up to 64 LPs if the attached PHY device supports the polling interface. When attached to a PHY device that only supports byte mode, the four direct status indicators can be used. Note that the two SPI-3 interfaces can be independently configured into either BYTE or PACKET modes. When the SPI Exchange is in PHY mode, the PACKET bit is used to select either a polled or direct status response to the attached Link device.

0 = BYTE mode with direct status indication for up to 4 LPs [3:0]
1 = PACKET mode with polled status for up to 64 LPs

SPI3_ENABLE A SPI-3 interface can be enabled or disabled according to the state programmed into this bit. A port should be disabled to save power if it is not used.

0=SPI-3 Physical port disabled, outputs are in tristate
1=SPI-3 Physical port enabled

BUSWIDTH A SPI-3 interface can be used as either a single 8-bit or 32-bit interface, according to the needs of the attached device. The SPI-3 ingress and egress of a given SPI-3 physical port will always be of the same bus width.

0=32 bit SPI-3 interface
1=8 bit SPI-3 interface

EVEN_PARITY A SPI-3 interface is provisioned to generate and to check for odd or even parity. The PARITY_EN bit must be set for this to become effective. Odd parity is standard for SPI-3 interfaces.

- 0=Odd parity on this port
- 1=Even parity on this port

PARITY_EN A SPI-3 interface is provisioned to enable or disable parity generation and checking, according to the state of the EVEN_PARITY bit.

- 0=Disable parity on this SPI-3 port
- 1=Enable parity on this SPI-3 port

WATERMARK A SPI-3 interface can be set to a SPI-3 ingress port watermark value. 0x10 is the highest watermark that can be set, meaning all ingress buffers will be full before backpressure will be initiated on a SPI-3 ingress interface. The WATERMARK field value of 0x08 is used to set the watermark for a half-full ingress buffer before tripping backpressure. The units of WATERMARK are one-sixteenth of the available ingress buffering per unit. Each unit is equal to 128 bytes. BACKPRESSURE_EN must be set [Register_offset 0x01] for the watermark to become effective. The watermark field is usually set to 0x10, and the FREE_SEGMENT field of Table 75, SPI-3 ingress port descriptor tables (Block_base 0x1200) is used for per LID backpressure.

SPI-3 ingress configuration register (Block_base 0x0200 + Register_offset 0x01)

TABLE 51 - SPI-3 INGRESS CONFIGURATION REGISTER (REGISTER_OFFSET=0x01)

Field	Bits	Length	Initial Value
BACKPRESSURE_EN	0	1	0b1
FIX_LP	1	1	0b0
Reserved	31:2	30	0x0000

There is one register for SPI-3 ingress configuration per SPI-3 interface. Each register has read and write access.

The bit fields for a SPI-3 ingress configuration register are described in the following paragraphs.

BACKPRESSURE_EN A SPI-3 interface can have backpressure enabled or disabled. Disabling backpressure means that data coming into the ingress may be lost if the SPI-3 interface ingress buffers overflow. The SPI-3 interface can run at full-rate, however, since there will be no backpressure. Attached devices that do not respond properly to backpressure should be interfaced by disabling backpressure.

Enabling backpressure will cause the I_ENB signal to be asserted when the ingress buffer fill level is equal to the WATERMARK value [Register_offset 0x00], or the free segment buffer threshold Table 75, SPI-3 ingress port descriptor table (Block_base 0x1200) has been reached for any active LID.

- 0=Disable backpressure on this SPI-3 ingress.
- 1=Enable backpressure on this SPI-3 ingress interface.

FIX_LP A SPI-3 interface can fix the logical port address to 0x00. This is useful when there is only one LP on an interface, such as with some single-PHY devices.

- 0= Do not fix logical port address to 0x00, but use the actual LP found in the packet fragments.
- 1= Fix logical port address to 0x00

SPI-3 ingress fill level register (Block_base 0x0200 + Register_offset 0x02)

TABLE 52 - SPI-3 INGRESS FILL LEVEL REGISTER (REGISTER_OFFSET=0x02)

Field	Bits	Length	Initial Value
FILL_CUR	4:0	5	0x00
I_FCLK_AV	5	1	0b1

There is one register for SPI-3 ingress fill level register per SPI-3 interface. Each register has read-only access. The bit fields of a SPI-3 ingress fill level register are described.

FILL_CUR Current SPI-3 ingress buffer fill level. Since this is a real-time register, the value read from it will change rapidly and is used for internal diagnostics only.

- I_FCLK_AV** Current SPI-3 ingress clock availability is checked here.
 - 0=SPI-3 ingress clock not detected on a SPI-3 port
 - 1=SPI-3 ingress clock transitions detected on a SPI-3 port

SPI-3 ingress max fill register (Block_base 0x0200 + Register_offset 0x03)

TABLE 53 - SPI-3 INGRESS MAX FILL LEVEL REGISTER (REGISTER_OFFSET=0x03)

Field	Bits	Length	Initial Value
FILL_MAX	4:0	5	0x00

There is one register for SPI-3 ingress max fill level register per SPI-3 interface. Each register has read-only access, and is cleared after reading. 0x10 is the highest filling level, meaning all ingress buffers had been full at some time since the last read of the FILL_MAX field. The units of FILL_MAX are one-sixteenth of the available ingress buffering. Each unit is equal to 128 bytes. The bit field of a SPI-3 ingress max fill level register is described. The Table 53 - SPI-3 ingress max fill level register (Register_offset=0x03) is for diagnostics only.

FILL_MAX Maximum SPI-3 ingress buffer fill level since the last read of the SPI-3 ingress max fill level register.

9.3.3 Block base 0x0500 registers

SPI-3 egress LID to LP map (Block_base 0x0500 + Register_offset 0x00-0x3F)

TABLE 54 - SPI-3 EGRESS LID TO LP MAP

Field	Bits	Length	Initial Value
LP	7:0	8	0x00
ENABLE	8	1	0b0
BIT_REVERSAL	9	1	0b0

There are 64 SPI-3 egress LID to LP maps per SPI-3 interface, one per potential SPI-3 LID.

The SPI-3 egress LID to LP maps have read and write access. The SPI-3 egress LID to LP maps are used to map SPI-3 egress logical identifiers to SPI-3 logical port addresses that are in-band with the SPI-3 egress packet fragments.

LP The LP programmed is associated to the LID with the same number as the register address.

ENABLE This bit is used to enable or disable the connection of a LID to an LP.

- 0=LP disabled
- 1=LP enabled

BIT_REVERSAL This bit is used to reverse the bit ordering of each byte of the SPI-3 interface on a per-LP basis.

- 0=Disable bit reversal for an LP
- 1=Enable bit reversal for an LP

9.3.4 Block base 0x0700 registers

SPI-3 egress configuration register (Block_base 0x0700 + Register_offset 0x00)

TABLE 55 - SPI-3 EGRESS CONFIGURATION REGISTER (REGISTER_OFFSET=0x00)

Field	Bits	Length	Initial Value
POLL_LENGTH	5:0	6	0x0F
Reserved	7:6	2	0b00
STX_SPACING	8	1	0b0
EOP_SPACING	9	1	0b0
Reserved	31:10	22	0x00

There is one SPI-3 egress configuration register per SPI-3 interface. The SPI-3 egress configuration registers have read and write access. A SPI-3 egress configuration registers is used to control the poll sequence length of a SPI-3 egress interface when the SPI-3 interface is in Link mode. The SPI-3 egress configuration register is used to add two cycles to STX or EOP as required to interface to the attached device.

POLL_LENGTH Link layer poll sequence length when in Link mode. The poll sequence is from the LP associated with LID0 to the LP associated with the LID for POLL_LENGTH - 1.

STX_SPACING This bit is used to enable or disable the adding of two dummy STX cycles to a SPI-3 egress interface to meet the needs of an attached device.

- 0= No dummy STX cycles are added to a SPI-3 egress.
- 1= Two dummy STX cycles are added to a SPI-3 egress

EOP_SPACING This bit is used to enable or disable the adding of two dummy EOP cycles to a SPI-3 egress interface to meet the needs of an attached device.

- 0= No dummy EOP cycles are added to a SPI-3 egress.
- 1= Two dummy EOP cycles are added to a SPI-3 egress

SPI-4 ingress to SPI-3 egress flow control register (Block_base 0x0700 + Register_offset 0x01)

TABLE 56 - SPI-4 INGRESS TO SPI-3 EGRESS FLOW CONTROL REGISTER (REGISTER_OFFSET=0x01)

Field	Bits	Length	Initial Value
CREDIT_EN	0	1	0b0
BURST_EN	1	1	0b0
LOOP_BACK	2	1	0b0
Reserved	31:3	29	0x00

The SPI-4 ingress to SPI-3 egress flow control register has read and write access. The bit fields of the SPI-4 ingress to SPI-3 egress flow control register are described.

CREDIT_EN CREDIT_EN The flow control information received from the attached SPI-3 device is interpreted as status or credit information as selected by the CREDIT_EN bit in the SPI-4 ingress to SPI-3 egress flow control Register. If the status mode is used, data will be egressed until the status is changed by the attached SPI-3 device. If the credit mode is used, the SPI-3 egress will transmit only one packet fragment and then wait for an update in the internal buffer segment pool status before sending another packet fragment.

- 0=Status mode
- 1=Credit mode

BURST_EN Multiple Burst Enable allows more than one burst to be sent to an LP. When this feature is not enabled, only one burst per LP is allowed into the SPI-3 egress buffers.

- 0=Disable burst enable
- 1=Enable burst enable

LOOP_BACK In this mode the contents of a SPI-3 ingress are directly transferred to a SPI-3 egress buffers of the same port. This mode is useful for off-line diagnostics.

- 0=Disable loopback
- 1=Enable loopback

SPI-3 egress test register (Block_base 0x0700 + Register_offset 0x02)

TABLE 57 - SPI-3 EGRESS TEST REGISTER (REGISTER_OFFSET=0x02)

Field	Bits	Length	Initial Value
ADD_PAR_ERR	0	1	0b0
DAT_PAR_ERR	1	1	0b0
Reserved	7:2	6	0x00
PORT_ADDRESS	15:8	8	0x0F

The SPI-3 egress test register has read and write access. A single address parity error is introduced on a SPI-3 egress LP through the ADD_PAR_ERR bit field. A single data parity error is introduced on a SPI-3 egress LP through

the DAT_PAR_ERR bitfield. The LP affected by these two parity error bit fields is enumerated in the PORT_ADDRESS field. The bit fields of SPI-3 egress test register are described. The bit fields are automatically cleared following the generation of the associated error.

ADD_PAR_ERR A single address parity error is introduced on a SPI-3 egress LP through the ADD_PAR_ERR bit field. The LP affected by the ADD_PAR_ERR bit field is enumerated in the PORT_ADDRESS field.

- 0=No parity error introduced
- 1=Introduce a single address parity error on a SPI-3 egress LP

DAT_PAR_ERR A single data parity error is introduced on a SPI-3 egress LP through the DAT_PAR_ERR bit field. The LP affected by the DAT_PAR_ERR bit field is enumerated in the PORT_ADDRESS field.

- 0=No parity error introduced
- 1=Introduce a single data parity error on a SPI-3 egress LP

PORT_ADDRESS The LP affected by both the ADD_PAR_ERR and the DAT_PAR_ERR bit fields is enumerated in the PORT_ADDRESS field. The value of the PORT_ADDRESS is set from 0x00 to 0xFF.

SPI-3 egress fill level register (Block_base 0x0700 + Register_offset 0x03)

TABLE 58 - SPI-3 EGRESS FILL LEVEL REGISTER (REGISTER_OFFSET=0x03)

Field	Bits	Length	Initial Value
FILL_CUR	3:0	4	0x0
Reserved	4	1	0x0
E_FCLK_AV	5	1	0b0

There is one register for SPI-3 egress fill level register per SPI-3 interface. Each register has read-only access. The bit fields of the SPI-3 egress fill level register are described.

FILL_CUR Current SPI-3 egress buffer fill level. Since this is a real-time register, the value read from it will change rapidly and is used for internal diagnostics only.

I_FCLK_AV Current SPI-3 egress clock availability is checked here.
 0=SPI-3 egress clock transitions were not detected on a SPI-3 port
 1=SPI-3 egress clock transitions were detected on a SPI-3 port

SPI-3 egress max fill level register (Block_base 0x0700 + Register_offset 0x04)

TABLE 59 - SPI-3 EGRESS MAX FILL LEVEL REGISTER (REGISTER_OFFSET=0x04)

Field	Bits	Length	Initial Value
FILL_MAX	3:0	4	0x0

There is one register for SPI-3 egress max fill Level per SPI-3 interface. Each register has read-only access, and is cleared after reading. 0xF is the highest filling level, meaning all egress buffers had been full at some time since the last read of the FILL_MAX field. The units of FILL_MAX are one-sixteenth of the available egress buffering. Each unit is equal to 128 bytes. The bit field of the SPI-3 egress max fill Level register is described.

FILL_MAX Maximum SPI-3 egress buffer fill level since the last read of the SPI-3 egress Max Fill Level Register

Performance monitor counters

Two categories of events are captured: LID and non LID associated events. If at least one event is captured in one of the interrupt indication registers, an active PMON service request is directed towards the interrupt module.

All events and diagnostics data are accumulated during an interval defined by the *time base event*. The data accumulated during the previous time period can be accessed by the indirect access scheme. The counters are cleared when the time base expires. All counters are saturating, and will not overflow.

9.3.5 Block base 0x0A00 registers

LID associated event counters (Block_base 0x0A00 + Register_offset 0x000 to 0x17F)

TABLE 60 - LID ASSOCIATED EVENT COUNTERS (0x000-0x17F)

Offset	Counter	Counter length (bits)
LID*6+0	SPI-3 ingress good packet counter	24
LID*6+1	SPI-3 ingress bad packet counter(error tagged)	24
LID*6+2	SPI-4 ingress good packet counter	24
LID*6+3	SPI-4 ingress bad packet counter(abort)	24
LID*6+4	SPI-3 egress packet counter	24
LID*6+5	SPI-4 egress packet counter	24

A set of event counters is provided for each of the 64 LIDs on each SPI-3 interface and for each LID to or from a SPI-4 module. LID associated event counters keep track of packets, packets not delineated by an SOP and an EOP, or error-tagged packets.

9.3.6 Block base 0x0C00 registers

Non LID associated event counters (Block_base 0x0C00 + Register_offset 0x00 to 0x0B)

TABLE 61 - NON LID ASSOCIATED EVENT COUNTERS (0x00 - 0x0B)

Offset	Counters	Subject to accumulation	Width
0x00	SPI-3 ingress bytes	All bytes of transfers for active SPI-3 (excluding address parity error) individual for A/B/C/D	29
0x01	SPI-3 ingress transfers	All transfers for active SPI-3	26
0x02	PFP3-4 ingress too long packet	SPI-3 ingress packets longer than MAX_LENGTH	8
0x03	PFP3-4 ingress too short packet	SPI-3 ingress packets shorter than MIN_LENGTH	8
0x04	SPI-3 ingress error tagged packet	Parity error on SPI-3 ingress	8
0x05	Reserved		8
0x06	SPI-4 ingress bytes	All bytes of transfers for SPI-4, individual for modules A and B	29
0x07	SPI-4 ingress transfers	All transfers for active SPI-4 for A and B; same value in A and B	26
0x08	PFP4-3 ingress too long packet	SPI-4 ingress packets longer than MAX_LENGTH	8
0x09	PFP4-3 ingress too short packet	SPI-4 ingress packets shorter than MIN_LENGTH	8
0x0A	SPI-4 ingress error tagged packet	DIP-4 error on ingress	8
0x0B	Reserved		8

Non LID Associated Event Counters are associated with SPI-3 and SPI-4 physical interfaces. The register offset is shown in the Offset column.

**Non LID associated interrupt indication register
(Block_base 0x0C00 + Register_offset 0x0C)**

TABLE 62 - NON LID ASSOCIATED INTERRUPT INDICATION REGISTER (REGISTER_OFFSET 0x0C)

Field	Bits	Length	Initial Value
SPI4_LOCK_UN	0	1	0b0
SPI3_LOCK_UN	1	1	0b0
SPI3_ICLK_UN	2	1	0b0
SPI3_ECLK_UN	3	1	0b0
SPI3_FLUSH	4	1	0b0
Reserved	31:5	27	0x0

The Non LID associated interrupt indication register is at Block_Base 0x0C00. The Non LID interrupt indication register is used to determine the status of SPI-3 and SPI-4 port interrupts. The Non LID associated interrupt indication register is read and subsequently a "1" is written to acknowledge individual interrupts in this register. An interrupt is generated when enabled by the corresponding enable flag in the Non LID associated interrupt indication register. The bit fields in the Non LID associated interrupt indication register are described.

SPI4_LOCK_UN The SPI-4 interface can create an event indicating that the SPI-4 ingress has dropped data due the unavailability of ingress buffering.
0=No operation
1=The SPI-4 interface has dropped data due the unavailability of ingress buffering.

SPI3_LOCK_UN A SPI-3 interface can create an event indicating that a SPI-3 ingress has dropped data due the unavailability of ingress buffering.
0=No operation
1=A SPI-3 interface has dropped data due the unavailability of ingress buffering.

SPI3_ICLK_UN A SPI-3 interface can create an event indicating that a SPI-3 ingress clock has failed. No transitions were detected on a SPI-3 ingress clock (I_FCLK)
0=No operation
1=A SPI-3 ingress clock has failed.

SPI3_ECLK_UN A SPI-3 interface can create an event indicating that a SPI-3 egress clock has failed. No transitions were detected on a SPI-3 egress clock (E_FCLK)
0=No operation
1=A SPI-3 egress clock has failed.

SPI3_FLUSH A SPI-3 interface can create an event indicating that a SPI-3 buffer has been flushed and data has been lost. A buffer is flushed if an address parity error is detected, or if an ingress buffer is not available at the time it is requested.
0=No operation
1=A SPI-3 buffer has been flushed.

**Non LID associated interrupt enable register
(Block_base 0x0C00 + Register_offset 0x0D)**

TABLE 63 - NON LID ASSOCIATED INTERRUPT ENABLE REGISTER (REGISTER_OFFSET 0x0D)

Field	Bits	Length	Initial Value
SPI4_LOCK_UN	0	1	0b0
SPI3_LOCK_UN	1	1	0b0
SPI3_ICLK_UN	2	1	0b0
SPI3_ECLK_UN	3	1	0b0
SPI3_FLUSH	4	1	0b0
Reserved	31:5	27	0x0000

The Non LID associated interrupt enable register is at Block_Base 0x0C00 + Register_offset 0x0D. The Non LID associated interrupt enable register is used to mask the status of SPI-3 and SPI-4 port interrupts in the Non LID associated interrupt indication register. The Non LID associated interrupt enable register has read and write access. The bit fields in the Non LID associated interrupt enable register are active "1" interrupt enables for the corresponding bit fields in the Non LID associated interrupt indication register.

**LID associated interrupt indication register
(Block_base 0x0C00 + Register_offset 0x0E)**

TABLE 64 - LID ASSOCIATED INTERRUPT INDICATION REGISTER (REGISTER_OFFSET 0x0E)

Field	Bits	Length	Initial Value
EVENT_TYPE	5:0	6	0x00
Reserved	31:6	26	0x0

The LID associated interrupt indication register is at Block_Base 0x0C00 + Register_offset 0x0E. The LID associated interrupt indication register is used to determine the EVENT_TYPE of SPI-3 and SPI-4 interrupts. The EVENT_TYPE coding is given in the Table 66 - Non critical LID associated capture table (0x10-0x15). The LID associated interrupt indication register is read and subsequently a 0xFF must be written for interrupt acknowledge. An EVENT_TYPE interrupt is generated when enabled by the EVENT_TYPE enable flag in the LID associated interrupt enable register.

**LID associated interrupt enable register
(Block_base 0x0C00 + Register_offset 0x0F)**

TABLE 65 - LID ASSOCIATED INTERRUPT ENABLE REGISTER (REGISTER_OFFSET 0x0F)

Field	Bits	Length	Initial Value
EVENT_TYPE	5:0	6	0x00
Reserved	31:6	26	0x0

The LID associated interrupt enable register is at Block_Base 0x0C00 + Register_offset 0x0F. The LID associated interrupt enable register is used to mask the EVENT_TYPE of SPI-3 and SPI-4 per-LID interrupts. The LID associated interrupt enable register has read and write access.

**Non critical LID associated capture table
(Block_base 0x0C00 + Register_offset 0x10-0x15)**

TABLE 66 - NON CRITICAL LID ASSOCIATED CAPTURE TABLE (REGISTER_OFFSET 0x10-0x15)

Register	EVENT_TYPE	Associated field
0x00	Inactive ingress SPI-3 logical port event	LP (8 bits)
0x01	SPI-3 ingress data parity error	LID (6 bits)
0x02	SPI-4 illegal SOP sequence event	LID (6 bits)
0x03	SPI-4 illegal EOP sequence event	LID (6 bits)
0x04	SPI-3 illegal SOP sequence event	LID (6 bits)
0x05	SPI-3 illegal EOP sequence event	LID (6 bits)

The Non critical LID associated capture table is at Block_Base 0x0C00 + Register_Offset 0x10-0x15. The Non critical LID associated capture table is used to determine the EVENT_TYPE of SPI-3 and SPI-4 per-LID or per-LP interrupts. The EVENT_TYPE coding is used to indicate which event or events are pertinent to the interrupt in the Table 64 - LID associated interrupt indication register(0x0E). The Non critical LID associated capture table is used to determine the EVENT, and multiple bits can be active at the same time. The Non critical LID associated capture table is read-only.

SPI-3 to SPI-4 critical LID interrupt indication registers (Block_base 0x0C00 + Register_offset 0x16-0x17)

TABLE 67 - SPI-3 TO SPI-4 CRITICAL LID INTERRUPT INDICATION REGISTERS (REGISTER_OFFSET 0x16-0x17)

Register	Field	Bits	Length	Initial Value
0x16	LID[31:0]	31:0	32	0x00
0x17	LID[63:32]	31:0	32	0x00

The SPI-3 to SPI-4 critical LID interrupt indication registers are at Block_Base 0x0C00 + Register_offset 0x16-0x17.

Critical events are captured per LID in the SPI-3 to SPI-4 critical LID interrupt indication registers. An interrupt is generated when enabled by the enable flag in the SPI-3 to SPI-4 critical LID interrupt enable registers. A SPI-3 to SPI-4 critical LID interrupt indication register has read and write access. An interrupt indication is cleared by writing a logical one to the appropriate bit of a SPI-3 to SPI-4 critical LID interrupt indication register. Only one kind of critical event is defined-buffer overflow. Each bit of the LID field set to logical one indicates the presence of a buffer overflow event. A summary indication of as to which of the two sources, SPI-3 to SPI-4 or SPI-4 to SPI-3, is responsible for the critical interrupt is indicated in the Table 71 Critical events source indication register (0x1E).

SPI-3 to SPI-4 critical LID interrupt enable registers (Block_base 0x0C00 + Register_offset 0x18-0x19)

TABLE 68 - SPI-3 TO SPI-4 CRITICAL LID INTERRUPT ENABLE REGISTERS (REGISTER_OFFSET 0x18-0x19)

Register	Field	Bits	Length	Initial Value
0x18	LID[31:0]	31:0	32	0x00
0x19	LID[63:32]	31:0	32	0x00

The SPI-3 to SPI-4 critical LID interrupt enable registers have read and write access. A SPI-3 to SPI-4 critical LID interrupt enable register bits enable the corresponding bits in a SPI-3 to SPI-4 critical LID interrupt indication register.

SPI-4 to SPI-3 critical LID interrupt indication registers (Block_base 0x0C00 + Register_offset 0x1A-0x1B)

TABLE 69 - SPI-4 TO SPI-3 CRITICAL LID INTERRUPT INDICATION REGISTERS (REGISTER_OFFSET 0x1A-0x1B)

Register	Field	Bits	Length	Initial Value
0x1A	LID[31:0]	31:0	32	0x00
0x1B	LID[63:32]	31:0	32	0x00

The SPI-4 to SPI-3 critical LID interrupt indication registers are at Block_Base 0x0C00 + Register_offset 0x1A-0x1B.

Critical events are captured per LID in a SPI-4 to SPI-3 critical LID interrupt indication register. An interrupt is generated when enabled by the enable flag in the SPI-4 to SPI-3 critical LID interrupt enable register. The SPI-4 to SPI-3 critical LID interrupt indication registers have read and write access. An interrupt indication is cleared by writing a logical one to the appropriate bit of a SPI-4 to SPI-3 critical LID interrupt indication register. Only one kind of critical event is defined-buffer overflow. Each bit of a LID field set to logical one indicates the presence of a buffer overflow event. A summary indication of as to which of the two sources, SPI-3 to SPI-4 or SPI-4 to SPI-3, is responsible for the critical interrupt is indicated in the Table 71 Critical events source indication register (0x1E).

SPI-4 to SPI-3 critical LID interrupt enable registers (Block_base 0x0C00 + Register_offset 0x1C-0x1D)

TABLE 70 - SPI-4 TO SPI-3 CRITICAL LID INTERRUPT ENABLE REGISTERS (REGISTER_OFFSET 0x1C-0x1D)

Register	Field	Bits	Length	Initial Value
0x1C	LID[31:0]	31:0	32	0x00
0x1D	LID[63:32]	31:0	32	0x00

The SPI-4 to SPI-3 critical LID interrupt enable registers have read and write access. The SPI-4 to SPI-3 critical LID interrupt enable register bits enable the corresponding bits in the SPI-4 to SPI-3 critical LID interrupt indication registers.

Critical events source indication register (Block_base 0x0C00 + Register_offset 0x1E)

TABLE 71 - CRITICAL EVENTS SOURCE INDICATION REGISTER (REGISTER_OFFSET 0x1E)

Field	Bits	Length	Initial Value
SPI34_OVR	0	1	0b0
SPI43_OVR	1	1	0b0
Reserved	31:2	30	0x0

The bits in the Critical events source indication register are read only. Bit SPI34_OVR reflects the logical OR result of all bits in the SPI-3 to SPI-4 critical LID associated interrupt indication registers. Bit SPI43_OVR reflects the logical OR result of all bits in the SPI-4 to SPI-3 critical LID interrupt indication registers.

9.3.7 Block base 0x0100 registers

SPI-3 ingress packet length configuration register (Block_base 0x1000 + Register_offset 0x00-0x3F)

TABLE 72 - SPI-3 INGRESS PACKET LENGTH CONFIGURATION REGISTER

Field	Bits	Length	Initial Value
MIN_LENGTH	7:0	8	0x40
Reserved	15:8	8	0x00
MAX_LENGTH	29:16	14	0x5EE

There is one set of SPI-3 ingress packet length configuration registers per SPI-3 ingress interface. Each SPI-3 ingress interface has 64 registers, one for each of the allowed LIDs supported per SPI-3 interface. Each register has read and write access. The minimum and maximum packet lengths per LID are provisioned using the SPI-3 ingress packet length configuration register. The bit fields of a SPI-3 ingress packet length configuration register are described.

MIN_LENGTH SPI-3 ingress minimum packet length. The minimum packet length is programmed from 0 to 255 bytes. The resolution of the minimum packet length is one byte.

MAX_LENGTH SPI-3 ingress maximum packet length. The maximum packet length is programmed from 0 to 16,383 bytes. The resolution of the maximum packet length is one byte.

9.3.8 Block base 0x1100 registers

SPI-4 egress port descriptor table (Block_base 0x1100 + Register_offset 0x00-0x3F)

TABLE 73 - SPI-4 EGRESS PORT DESCRIPTOR TABLE (64 ENTRIES)

Field	Bits	Length	Initial Value
MAX_BURST_H	3:0	4	0xF
MAX_BURST_S	7:4	4	0xF
DIRECTION	9:8	2	0x3
Reserved	31:10	22	0x000

There are two sets of SPI-4 egress port descriptor tables, one per SPI-3 interface. The minimum and maximum SPI-4 egress burst lengths per LID are provisioned using a SPI-4 egress port descriptor table. Each SPI-4 egress port descriptor table has read and write access. The bit fields of the SPI-4 egress port descriptor table are described. These fields need to be programmed only for SPI-4 egress (DIRECTION=0 in Table 74-SPI-4 egress direction code assignment).

MAX_BURST_H SPI-4 egress per-LID burst length when the attached device has declared hungry through the FIFO status channel. The number in the MAX_BURST_H field is taken to mean that one more than that number multiplied by 16 is the maximum hungry burst length. For example, programming the number 3 into the MAX_BURST_H field results in a maximum hungry burst size of (3 + 1) 9.3.9 Block base 0x1200 registers

MAX_BURST_S SPI-4 egress per-LID burst length when the attached device has declared starving through the FIFO status channel. The number in the MAX_BURST_S field is taken to mean that one more than that number

multiplied by 16 is the maximum starving burst length. For example, programming the number 7 into the MAX_BURST_S field results in a maximum starving burst size of (7 + 1) x 16 = 128 bytes. The MAX_BURST_S field should not be set to less than the MAX_BURST_H field.

DIRECTION The SPI-4 egress traffic can be captured by the microprocessor, directed to a SPI-3 egress port, to the SPI-4 egress port, or discarded. The Path selection is defined for each of the 64 LIDs by the associated DIRECTION field as shown in the following table.

TABLE 74 - SPI-4 EGRESS DIRECTION CODE ASSIGNMENT

DIRECTION	Path
00	SPI-4
01	Associated SPI-3
10	Capture to microprocessor
11	Discard

9.3.9 Block base 0x1200 registers

SPI-3 ingress port descriptor tables (Block_base 0x1200 + Register_offset 0x00-0x3F)

TABLE 75 - SPI-3 INGRESS PORT DESCRIPTOR TABLE (BLOCK_BASE 0x1200)

Field	Bits	Length	Initial Value
M	8:0	9	0x000
Reserved	15:9	7	0x00
Reserved	20:16	5	0x00
Reserved	23:21	3	0x0
FREE_SEGMENT	28:24	5	0x00
Reserved	31:29	3	0x0

There is one set of 64 SPI-3 ingress port descriptor tables per SPI-3 ingress interface. The SPI-3 ingress port descriptor tables are at Block_base 0x1200 and have read and write access. Each SPI-3 ingress interface has 64 table entries for per-LID provisioning of M and FREE_SEGMENT fields. The SPI-3 ingress port descriptor tables are used to control the amount of buffering and the free segment backpressure threshold of the available buffer segment pool for a SPI-3 ingress on a per-LID basis.

Each SPI-3 buffer segment pool is 128 Kbytes, divided into 508 segments of 256 bytes per segment. These 508 segments are shared among the LIDs initially programmed into the NR_LID fields. A SPI-3 ingress LID can be allocated the maximum number of segments out of the available buffer segments, or can be programmed to fewer segments by decreasing the M field.

The FREE_SEGMENT field is used, along with the M field, to set the free segment backpressure threshold for a LID on a SPI-3 ingress.

M The number of 256-byte buffer pool segments on a SPI-3 ingress port allocated to a LID. The range of M is 0x000 to 0x1FC (508 base 10), but can not exceed the number set by the choice of NR_LID [Block_base 0x1300 + Register_offset 0x00].

FREE_SEGMENT The FREE_SEGMENT field is used to define the SPI-3 ingress per-LID free segment backpressure threshold based on the number of free buffer segments (M) available, as follows:

$$\text{THRESHOLD} = N * \text{FREE_SEGMENT}$$

Where the value of N is defined as a function of the domain of M:

M[8:0]	N (base 10)
0x1FC to 0x100	16
0x0FF to 0x080	8
0x07F to 0x040	4
0x03F to 0x020	2
0x01F to 0x000	1

The THRESHOLD thus defined is the number of free segments available for a LID at the time of backpressure initiation.

9.3.10 Block base 0x1300 registers

The SPI-3 ingress to SPI-4 egress Packet Fragment Processor and flow control registers are at Block_Base 0x1300.

SPI-3 to SPI-4 PFP register (Block_base 0x1300 + Register_offset 0x00)

TABLE 76 - SPI-3 TO SPI-4 PFP REGISTER (REGISTER_OFFSET 0x00)

Field	Bits	Length	Initial Value
NR_LID	2:0	3	0b011
Reserved	7:3	5	0x0

A SPI-3 ingress to SPI-4 egress PFP (Packet Fragment Processor) Register has read and write access. There is one SPI-3 to SPI-4 PFP Register per SPI-3 ingress. The bit fields of a SPI-3 to SPI-4 PFP Register are described.

NR_LID The maximum number of LIDs per SPI-3 physical ingress interface that will ever be used is programmed into the NR_LID field. Once configured after reset, this value can not be changed. Fewer LIDs can be used by not activating some of the LIDs, but more LIDs than the value in NR_LID are not allowed and will generate an error. The NR_LID field is important, as the buffer segment pool is divided among the number of LIDs programmed into the NR_LID field.

A 128 Kbyte SPI-3 to SPI-4 buffer segment pool for storing data bursts for the SPI-4 egress is available for each SPI-3 physical port. A configurable part of this buffer segment pool can be assigned to each of the possible LIDs allowed by the NR_LID field value per SPI-3 physical interface. The buffer size for a LID can be configured in multiples (M) of 256 bytes. Modifications of the buffer size allocated to a LID are supported only when the logical port associated to the LID is disabled. Attempts to allocate more memory than available will generate an allocation error event. The indirect access module will discard the attempt.

A 128 Kbyte SPI-3 to SPI-4 buffer segment pool is divided into 508 buffer segments. Each buffer segment is equal to 256 bytes. The buffer segments are shared among the number of logical ports defined by the static NR_LID

configuration. The buffer segments do not have to be equally shared among the LIDs. One buffer segment corresponds to a data burst to be forwarded to the SPI-4 egress interface.

An example of the use of the buffer segment pool follows. For a SPI-3 ingress interface that will never have more than four LIDs, set the NR_LID field for this interface to 0x01. This allows 256 buffer segments for a LID, with the total number of buffer segments for all 4 LIDs equal to 508. Let's say you want only 64 buffer segments for one of the LIDs. Program field M for that LID to 0x040 (64 base 10). Let's say you want to backpressure the SPI-3 ingress interface when 48 of the 64 allocated buffers for this LID are full. In other words, you want to exert SPI-3 ingress backpressure when only 16 segments remain for this LID. Since M=0x040, N=4 from the description of the M field above [Block_base 0x1200]. Setting the FREE_SEGMENT field to 4 then yields the desired THRESHOLD of 16.

TABLE 77 - NR_LID FIELD ENCODING

NR_LID	Maximum Number of LIDs	Maximum Buffer Segments for a LID
0b000	1	508
0b001	4	256
0b010	8	128
0b011	16	64
0b100	32	32
0b101	64	16

SPI-3 to SPI-4 flow control register (Block_base 0x1300 + Register_offset 0x01)

TABLE 78 - SPI-3 TO SPI-4 FLOW CONTROL REGISTER (REGISTER_OFFSET 0x01)

Field	Bits	Length	Initial Value
CREDIT_EN	0	1	0b1
BURST_EN	1	1	0b0
Reserved	7:3	6	0x00

A SPI-3 to SPI-4 flow control register has read and write access. There is one SPI-3 to SPI-4 flow control register per SPI-3 ingress. The bit fields of the SPI-3 to SPI-4 flow control register are described.

CREDIT_EN The information received over the FIFO status channel is interpreted as status or credit information as selected by the CREDIT_EN flag in the SPI-3 to SPI-4 flow control Register. If the status mode is used, data will be egressed until the status is changed by the attached device. If the credit mode is used, the SPI-4 egress will issue only one credit's worth data burst and then wait for another credit from the status channel before issuing another LID burst.

- 0=Status mode
- 1=Credit mode

BURST_EN Multiple Burst Enable allows more than one burst to be sent to an LP. This feature is included to relieve systems with long latency between updates. When this feature is not enabled, only one burst per LP is allowed into the SPI-4 egress buffers.

- 0=Disable burst enable
- 1=Enable burst enable

9.3.11 Block base 0x1600 registers

The SPI-4 ingress registers are at Block_base 0x1600.

SPI-4 ingress packet length configuration (Block_base 0x1600 + Register_offset 0x00-0x3F)

TABLE 79 - SPI-4 INGRESS PACKET LENGTH CONFIGURATION (64 ENTRIES CONFIGURABLE)

Field	Bits	Length	Initial Value
MIN_LENGTH	7:0	8	0x40
Reserved	15:8	8	0x0
MAX_LENGTH	29:16	14	0x5EE

There are two sets of 64 registers for SPI-4 ingress packet length configuration, one per SPI-3 interface. Each register has read and write access. The minimum and maximum packet lengths per LID are provisioned using the SPI-4 ingress packet length configuration register. The bit fields of a SPI-4 ingress packet length configuration register are described.

MIN_LENGTH SPI-4 ingress minimum packet length. The minimum packet length is programmed from 0 to 255 bytes. The resolution is one byte.

MAX_LENGTH SPI-4 ingress maximum packet length. The maximum packet length is programmed from 0 to 16,383 bytes. The resolution is one byte.

9.3.12 Block base 0x1700 registers SPI-3 egress port descriptor table (Block_base 0x1700 + Register_offset 0x00-0x3F)

TABLE 80 - SPI-3 EGRESS PORT DESCRIPTOR TABLE (64 ENTRIES)

Field	Bits	Length	Initial Value
MAX_BURST	3:0	4	0x0F
Reserved	7:4	4	0x0
DIRECTION	8:9	2	0b11
Reserved	31:10	22	0x00

There are 64 SPI-3 egress port descriptor tables per SPI-3 egress port. The SPI-3 egress port descriptor table has read and write access. The SPI-3 egress per LID packet fragment length and direction are provisioned using the SPI-3 egress port descriptor tables. The bit fields of a SPI-3 egress port descriptor table are described.

MAX_BURST SPI-3 packet fragment length for a SPI-3 egress LP. One more than MAX_BURST field multiplied by sixteen is the packet fragment length for the LP. For example, programming the number 3 into the MAX_BURST field results in a packet fragment length of (3+1) x 16 = 64 bytes. The MAX_BURST field is used to prioritize traffic.

DIRECTION The SPI-3 egress traffic is directed to a SPI-3 egress port. The Path selection is defined for each of the 64 LIDs by the associated DIRECTION field as shown in the following table.

TABLE 81 - SPI-3 EGRESS DIRECTION CODE ASSIGNMENT

DIRECTION	Path
00	SPI-3 physical
01	Reserved
10	Capture
11	Discard

9.3.13 Block base 0x1800 registers SPI-4 ingress port descriptor table (Block_base 0x1800 + Register_offset 0x00-0x3F)

TABLE 82 - SPI-4 INGRESS PORT DESCRIPTOR TABLES (64 ENTRIES)

Field	Bits	Length	Initial Value
M	8:0	9	0x000
Reserved	15:9	7	0x00
FREE_SEGMENT_S	20:16	5	0x00
Reserved	23:21	3	0x0
FREE_SEGMENT_H	28:24	5	0x00
Reserved	31:29	3	0x0

There is one set of 64 registers for SPI-4 ingress port descriptors per SPI-3 interface. The SPI-4 ingress port descriptor tables are 32 bits wide and have read and write access. Each of the SPI-4 ingress port descriptor tables is used to control the amount of buffering and the backpressure threshold of the available buffer segment pool for the SPI-4 ingress.

Each SPI-4 ingress buffer segment pool is 128 Kbytes, divided into 508 buffer segments of 256 bytes per segment. The 508 buffer segments can be shared among the LIDs initially programmed by the numerical field NR_LID. Of the share of the buffer memory, a SPI-4 LID can be allocated the maximum number of segments permitted, or can be programmed to fewer segments by decreasing the M field. Decreasing M increases the chance of backpressure and possibly buffer overflow, but can result in lower latency.

The FREE_SEGMENT_S (starving threshold) and FREE_SEGMENT_H (hungry threshold) fields are used, along with the M field, to set the two backpressure settings per LID on the SPI-4 ingress. The FREE_SEGMENT_S field must always be greater than the FREE_SEGMENT_H field.

M The number of 256-byte buffer pool segments allocated to a LID. The range of M is 0x000 to 0x1FC (508 base 10), but can not exceed the number dictated by NR_LID [Block_base 0x1900 + Register_offset 0x00].

FREE_SEGMENT_S

This field is used to define the SPI-4 ingress per-LID starving backpressure threshold based on the number of free buffer pool segments (M) available, as follows:

$THRESHOLD_S = N * FREE_SEGEMENT_S$, where the value of N is defined as:

M[8:0]	N
0x1FF to 0x100	16
0x0FF to 0x080	8
0x07F to 0x040	4
0x03F to 0x020	2
0x01F to 0x000	1

FREE_SEGMENT_H

This field is used to define the SPI-4 ingress per-LID hungry backpressure threshold based on the number of free buffer pool segments (M) available, as follows:

$THRESHOLD_H = N * FREE_SEGEMENT_H$, where the value of N is as defined for FREE_SEGMENT_S.

9.3.14 Block base 0x1900 registers SPI-4 to SPI-3 PFP register (Block_base 0x1900 + Register_Offset 0x00)

TABLE 83 - SPI-4 TO SPI-3 PFP REGISTER (0x00)

Field	Bits	Length	Initial Value
NR_LID	2:0	3	0b011
Reserved	7:3	5	0x00

The SPI-4 ingress to SPI-3 egress Packet Fragment Processor registers are at Block_Base 0x1900 + Register_offset 0x00. A SPI-4 to SPI-3 PFP Register has read and write access. The bit fields of a SPI-4 to SPI-3 PFP Register are described.

NR_LID The maximum number of LIDs per SPI-3 physical interface that will ever be used is programmed into the NR_LID field. Once configured after reset, this value can not be changed. Fewer LIDs can be used by not activating some of the LIDs, but more LIDs than the value in NR_LID are not allowed and will generate an error. The NR_LID field is important, as the buffer segment pool is divided among the number of LIDs programmed into the NR_LID field.

A 128 Kbyte SPI-4 to SPI-3 buffer segment pool for storing packet fragments for a SPI-3 egress is available per SPI-3 physical port. A configurable part of the buffer segment pool can be assigned to each of the LIDs, as determined by the NR_LID value, per SPI-3 physical interface. The buffer size (M) for a LID can be configured in multiples of 256 bytes. Modifications of the buffer size allocated to a LID are supported only when the logical port associated to the LID is disabled. Attempts to allocate more memory than available will generate an allocation error event. The indirect access module will discard the attempt.

The 128 Kbyte SPI-4 to SPI-3 buffer segment pool is divided into 508 buffer segments. Each buffer segment is equal to 256 bytes. The buffer segments are shared among the number of logical ports defined by the static NR_LID configuration. The buffer segments do not have to be equally shared among the allocated LIDs. One buffer segment corresponds to a packet fragment to be forwarded to a SPI-3 egress physical interface.

An example of the use of the buffer segment pool follows. For a SPI-3 egress interface that will never have more than eight LIDs, set the NR_LID field for this interface to 0x02. This allows 128 buffer segments for a LID with the total number of buffer segments for all eight LIDs equal to 508.

Let's say you want only 24 (base 10) buffer segments for one of the LIDs. Program field M for that LID to 0x018 (24 base 10). Let's say you want to set the per-LID starving backpressure for the SPI-4 ingress interface when 20 of the 24 allocated buffers for this LID are full. In other words, you want to assert SPI-4 ingress starving when only 4 segments remain for this LID. Since M=0x018, N=1 from the description of the M field above [Block_base 0x1800]. Setting the FREE_SEGMENT_S field to 4 then yields the desired THRESHOLD_S of 4. Similarly, to set the per-LID SPI-4 ingress hungry threshold, THRESHOLD_H, to trip when only 6 buffer segments remain for this LID, program the FREE_SEGMENT_H field for this LID to 6.

TABLE 84 - NR_LID FIELD ENCODING

NR_LID	Maximum Number of LIDs	Maximum Buffer Segments for a LID
0b000	1	508
0b001	4	256
0b010	8	128
0b011	16	64
0b100	32	32
0b101	64	16

9.4 Common module indirect registers (Module_base 0x8000)

TABLE 85 -COMMON MODULE (MODULE_BASE 0x8000) INDIRECT REGISTER TABLE

Table Number, Page	Block_base, Register_offset	Title of Register
86, page 69	0x0000, 0x00-0xFF	SPI-4 ingress LP to LID map
87, page 69	0x0100, 0x00-0xFF	SPI-4 ingress calendar_0
88, page 69	0x0200, 0x00-0xFF	SPI-4 ingress calendar_1
89, page 69	0x0300, 0x00	SPI-4 ingress configuration register
90, page 70	0x0300, 0x01	SPI-4 ingress status configuration register
91, page 70	0x0300, 0x02	SPI-4 ingress status register
92, page 70	0x0300, 0x03	SPI-4 ingress inactive transfer port
93, page 71	0x0300, 0x04-0x05	SPI-4 ingress calendar configuration register
94, page 71	0x0300, 0x06	SPI-4 ingress watermark register
95, page 71	0x0300, 0x07-0x0A	SPI-4 ingress fill level register
96, page 71	0x0300, 0x0B-0x0E	SPI-4 ingress max fill level register
97, page 71	0x0300, 0x0F	SPI-4 ingress diagnostics register
98, page 72	0x0300, 0x10	SPI-4 ingress DIP-4 error counter
99, page 72	0x0300, 0x11	SPI-4 ingress bit alignment control register
100, page 72	0x0300, 0x12	SPI-4 ingress start up training threshold register
101, page 72	0x0400, 0x00-0xFF	SPI-4 egress LID to LP map
102, page 72	0x0500, 0x00-0xFF	SPI-4 egress calendar_0
103, page 73	0x0600, 0x00-0xFF	SPI-4 egress calendar_1
104, page 73	0x0700, 0x00	SPI-4 egress configuration register_0
105, page 73	0x0700, 0x01	SPI-4 egress configuration register_1
106, page 74	0x0700, 0x02	SPI-4 egress status register
107, page 74	0x0700, 0x03-0x04	SPI-4 egress calendar configuration register
108, page 74	0x0700, 0x05	SPI-4 egress diagnostics register
109, page 74	0x0700, 0x06	SPI-4 egress DIP-2 error counter
110, page 75	0x0800, 0x00	SPI-4 ingress bit alignment window register
111, page 75	0x0800, 0x01	SPI-4 ingress lane measure register
112, page 75	0x0800, 0x02-0x0B	SPI-4 ingress bit alignment counter register
113, page 75	0x0800, 0x0C-0x1F	SPI-4 ingress manual alignment phase/result register
114, page 75	0x0800, 0x2A	SPI-4 egress data lane timing register
115, page 76	0x0800, 0x2B	SPI-4 egress control lane timing register
116, page 76	0x0800, 0x2C	SPI-4 egress data clock timing register
117, page 76	0x0800, 0x2D	SPI-4 egress status timing register
118, page 76	0x0800, 0x2E	SPI-4 egress status clock timing register
119, page 77	0x0900, 0x00	PMON timebase control register
120, page 77	0x0900, 0x01	Timebase register
121, page 77	0x0900, 0x10	Clock generator control register
122, page 77	-----	OCLK and MCLK frequency select encoding
123, page 78	0x0900, 0x20	GPIO register
124, page 78	0x0900, 0x21- 0x25	GPIO monitor table
125, page 78	0x0900, 0x30	Version number register

9.4.1 Common module block base 0x0000 registers SPI-4 ingress LP to LID maps (Block_base 0x0000 + Register_offset 0x00 to 0xFF)

TABLE 86 - SPI-4 INGRESS LP TO LID MAP (256 ENTRIES, ONE PER LP)

Field	Bits	Length	Initial Value
LID	5:0	6	0x00
PFP	7:6	2	0x0
ENABLE	8	1	0x0

There are 256 SPI-4 ingress LP to LID maps for the SPI-4 ingress interface at Block_base 0x0000. The SPI-4 ingress LP to LID maps have read and write access. The SPI-4 ingress LP to LID maps are used to map SPI-4 ingress logical ports to logical identifiers used internally.

Data for an inactive LP having an entry in the calendar is forwarded to LID0. Therefore all the LPs that have entries in the calendar tables should be enabled.

LID The LID programmed is associated to the LP with the same number as the register address. Six bits support the 64 simultaneously active LIDs per SPI-3 physical interface.

PFP The PFP field is used to select among SPI-4 ingress to SPI-3 egress Packet Processing Engines. The number in the PFP field selects the PFP module to be used.

- 0x0=Select PFP Module A
- 0x1=Select PFP Module B
- 0x2=Reserved
- 0x3=Reserved

ENABLE The Enable is used to enable or disable the connection of an LP to a LID.

- 0=LP is disabled
- 1=LP is enabled

9.4.2 Common module block base 0x0100 registers SPI-4 ingress calendar_0 (Block_base 0x0100 + Register_offset 0x00 to 0xFF)

TABLE 87 - SPI-4 INGRESS CALENDAR_0 (256 ENTRIES)

Field	Bits	Length	Initial Value
LP	7:0	8	0xFF

The SPI-4 ingress calendar_0 is at Block_base 0x0100 and has read and write access. When the SPI-4 ingress calendar_0 is selected, SPI-4 ingress calendar_0 is in use. There are 256 entries in the SPI-4 ingress calendar_0 to schedule the updating of the FIFO status channel LPs to the attached device. If less than the maximum 256 LPs are needed on the SPI-4 interface, the calendar entries should be used for scheduling more frequent status updates for higher-speed LPs. The value of time-critical LPs must appear multiple times in the table. For example, a multi-PHY SPI-4 could have OC-48 channels appear in the calendar at four times the rate of OC-12 channels, since the higher data rate of the OC-48 channels would benefit from more frequent FIFO status channel updates. The LP field values range from 0x00 to 0xFF. The IDT88P8342 and the attached device must have identical calendars for ingress and the attached egress device. The ingress and egress calendars of the IDT88P8342 device do not have to match.

LP The LP value programmed schedules a status channel update according to the calendar sequence.

9.4.3 Common module block base 0x0200 registers SPI-4 ingress calendar_1 (Block_base 0x0200 + Register_offset 0x00 to 0xFF)

TABLE 88 - SPI-4 INGRESS CALENDAR_1 (256 ENTRIES)

Field	Bits	Length	Initial Value
LP	7:0	8	0xFF

The SPI-4 ingress calendar_1 is at Block_base 0x0200 and has read and write access. When the SPI-4 ingress calendar_1 is selected, SPI-4 ingress calendar_1 is in use. There are 256 entries in the SPI-4 ingress calendar_1 to schedule the updating of the FIFO status channel LPs to the attached device. If less than the maximum 256 LPs are needed on the SPI-4 interface, the calendar entries should be used for scheduling more frequent status updates for higher-speed LPs. The value of time-critical LPs must appear multiple times in the table. For example, a multi-PHY SPI-4 could have OC-48 channels appear in the calendar at four times the rate of OC-12 channels, since the higher data rate of the OC-48 channels would benefit from more frequent FIFO status channel updates. The LP field values range from 0x00 to 0xFF. The IDT88P8342 and the attached device must have identical calendars for ingress and the attached egress device. The ingress and egress of the IDT88P8342 do not have to match, however.

LP The LP value programmed schedules a status channel update according to the calendar sequence.

9.4.4 Common module block base 0x0300 registers SPI-4 ingress configuration register (Block_base 0x0300 + Register_offset 0x00)

TABLE 89 - SPI-4 INGRESS CONFIGURATION REGISTER (0x00)

Field	Bits	Length	Initial Value
SPI-4_EN	0	1	0b0
Reserved	1	1	0x0
Reserved	2	1	0x0
I_CLK_EDGE	3	1	0x0
I_DSC	4	1	0x0
I_INSYNC_THR	9:5	5	0x1F
I_OUTSYNC_THR	13:10	4	0xF
I_CSW_EN	14	1	0x0
CAL_SEL	15	1	0x0
I_LOW	16	1	0b1

The SPI-4 ingress configuration register is at Block_base 0x0300 and has read and write access.

The SPI-4 ingress configuration register is used to set the state of the SPI-4 ingress interface. The bit fields of the SPI-4 ingress configuration register are described.

SPI-4_EN The SPI-4 ingress path is enabled using this field. The SPI-4 path is disabled during reset and while configuring the port, and then is enabled for normal use.

- 0=SPI-4 ingress is disabled
- 1=SPI-4 ingress is enabled

I_CLK_EDGE The SPI-4 ingress LVTTTL status clock active clock edge is selected using the I_CLK_EDGE field.

- 0=SPI-4 ingress clock uses the rising edge
- 1=SPI-4 ingress clock uses the falling edge

I_DSC The I_DSC bit is used to protect against a random data error during de-skew.

- 0= One de-skew result is needed for data de-skew
- 1= Two consecutive de-skew results are needed for data de-skew (recommended setting)

I_INSYNC_THR The SPI-4 ingress DIP-4 in synchronization threshold is controlled using the I_INSYNC_THR field. It is recommended to use the initial value.

I_OUTSYNC_THR The SPI-4 ingress DIP-4 out-of synchronization threshold is controlled using the I_OUTSYNC_THR field. It is recommended to use the initial value.

I_CSW_EN The ingress calendar switch enable bit is used to enable the switching of the active calendars. It is recommended to use the initial value.

- 0=Ingress calendar switch disabled. Only SPI-4 ingress calendar_0 is used.
- 1=Ingress calendar switch enabled. Calendar_0 or calendar_1 can be used.

CAL_SEL The calendar select bit selects between SPI-4 ingress calendar_0 and SPI-4 ingress calendar_1. The CAL_SEL bit is only valid if the I_CSW_EN bit is set to a logic one.

- 0=SPI-4 ingress calendar_0 is selected
- 1=SPI-4 ingress calendar_1 is selected if the I_CSW_EN bit is set to a logic one

I_LOW The I_LOW field selects the SPI-4 ingress clock frequency range.

- 0=SPI-4 ingress clock is greater than or equal to 200 MHz
- 1=SPI-4 ingress clock is less than 200 MHz

SPI-4 ingress status configuration register (Block_base 0x0300 + Register_offset 0x01)

TABLE 90 - SPI-4 INGRESS STATUS CONFIGURATION REGISTER (REGISTER_OFFSET 0x01)

Field	Bits	Length	Initial Value
FIFO_MAX_T	23:0	24	0
ALPHA_FIFO	31:24	8	0

The SPI-4 ingress status configuration register is at Block_base 0x0300 and has read and write access.

The SPI-4 ingress status configuration register is used to set the state of the SPI-4 ingress FIFO status path interface. The bit fields of the SPI-4 ingress status configuration register are described.

FIFO_MAX_T The SPI-4 ingress FIFO_MAX_T field is the maximum time interval between scheduling of training sequences on the FIFO status path interface. The units are the number of times the calendar is sent before scheduling the training sequence.

ALPHA_FIFO The SPI-4 ingress ALPHA_FIFO field is the number of repetitions of the status training sequence that must be scheduled every FIFO_MAX_T cycles. The value for alpha used is actually one more than the ALPHA_FIFO value programmed into the ALPHA_FIFO field.

SPI-4 ingress status register (Block_base 0x0300 + Register_offset 0x02)

TABLE 91 - SPI-4 INGRESS STATUS REGISTER (REGISTER_OFFSET 0x02)

Field	Bits	Length	Initial Value
I_SYNCH	0	1	0
I_DSK_OOR	1	1	0
DCLK_AV	2	1	0

The SPI-4 ingress status register is at Block_base 0x0300 and has read-only access.

The SPI-4 ingress status register is used to set the state of the SPI-4 ingress synchronization.

The bit fields of the SPI-4 ingress status register are described.

I_SYNCH The SPI-4 ingress I_SYNCH field describes the synchronization state of the SPI-4 ingress data path.

- 0=SPI-4 ingress data path is out of synchronization
- 1=SPI-4 ingress data path is in synchronization

I_DSK_OOR The SPI-4 ingress I_DSK_OOR field describes the de-skew state of the SPI-4 ingress data path.

- 0=SPI-4 ingress data path de-skew is within range
- 1=SPI-4 ingress data path de-skew is out of range

DCLK_AV The SPI-4 ingress DCLK_AV field describes the availability state of the SPI-4 ingress clock.

- 0=SPI-4 ingress clock is not available
- 1=SPI-4 ingress clock is available

SPI-4 ingress inactive transfer port (Block_base 0x0300 + Register_offset 0x03)

TABLE 92 - SPI-4 INGRESS INACTIVE TRANSFER PORT (REGISTER_OFFSET 0x03)

Field	Bits	Length	Initial Value
INACT_LP	7:0	8	0

The SPI-4 ingress inactive transfer port is at Block_base 0x0300 and has read-only access.

The SPI-4 ingress inactive transfer port INACT_LP field is used to monitor the LP associated with the latest inactive transfer. The INACT_LP field can change at any time and is used for diagnostics only.

INACT_LP The SPI-4 ingress INACT_LP field contains the numeric value of the LP associated with the last inactive LP transfer, used for diagnostics only.

SPI-4 ingress calendar configuration register (Block_base 0x0300 + Register_offset 0x04 - 0x05)

TABLE 93 - SPI-4 INGRESS CALENDAR CONFIGURATION REGISTER (0x04 to 0x05)

Field	Bits	Length	Initial Value
I_CAL_M	7:0	8	0
I_CAL_LEN	13:8	6	0x01

The SPI-4 ingress calendar configuration registers are at Block_base 0x0300 and have read and write access. The Register_offset for calendar_0 is 0x04. The Register_offset for calendar_1 is 0x05.

The bit fields of a SPI-4 ingress calendar configuration register are described.

Some devices have a fixed calendar length and a fixed calendar M, while the Bridgeport calendar length has to be multiply of 4, and the calendar M is programmable. Therefore, the user may need to add an FPGA between the Bridgeport & the adjacent device SPI-4 status signals.

I_CAL_M The I_CAL_M value programmed defines the number of times the calendar sequence is repeated before a DIP-2 parity and "1 1" framing words are inserted. The actual calendar_M value used is one more than the value programmed into the I_CAL_M field.

I_CAL_LEN The I_CAL_LEN value programmed defines the length of the SPI-4 ingress calendar. The actual length of the calendar is four times the value of one more than the I_CAL_LEN field: $(I_CAL_LEN + 1) * 4$. For example, if the I_CAL_LEN field is programmed to 0x04, the actual value used is 0x14. The calendar length must be at least as large as the number of active SPI-4 ingress LPs.

SPI-4 ingress watermark register (Block_base 0x0300 + Register_offset 0x06)

TABLE 94 - SPI-4 INGRESS WATERMARK REGISTER (REGISTER_OFFSET 0x06)

Field	Bits	Length	Initial Value	Function
WATERMARK	4:0	5	0x0D	Watermark for PFP A
reserved	7:5	3	0	
WATERMARK	12:6	5	0x0D	Watermark for PFP B
reserved	15:13	3	0	
Reserved	20:16	5	0x0D	
reserved	23:21	3	0	
Reserved	28:24	5	0x0D	
reserved	31:29	3	0	

SPI-4 ingress Watermark Register is at Block_base 0x0300, Register_offset 0x06. The SPI-4 ingress Watermark Register has read and write access. A SPI-4 interface can be set to a Watermark Value per PFP. 0x1F is the highest watermark that can be set, meaning all ingress buffers will be full before backpressure will be initiated on a SPI-4 ingress interface PFP. A WATERMARK field value of 0x0F is used to set a watermark for a half-full ingress buffer before tripping backpressure. The units of WATERMARK are one-thirty-second of the available ingress buffering per unit. Each unit is equal to 128 bytes.

SPI-4 ingress fill level register (Block_base 0x0300 + Register_offset 0x07 - 0x08)

TABLE 95 - SPI-4 INGRESS FILL LEVEL REGISTER (0x07 to 0x08)

Field	Bits	Length	Initial Value
FILL_CUR	5:0	6	0x0

There is one register for SPI-4 ingress fill level register per SPI-3 interface at Block_base 0x0300. Each register has read-only access.

The SPI-4 ingress Fill Level Register for PFP A is at Block_base 0x0300 + Register_offset 0x07.

The SPI-4 ingress Fill Level Register for PFP B is at Block_base 0x0300 + Register_offset 0x08.

The bit fields of a SPI-4 ingress fill level register are described.

FILL_CUR Current SPI-4 ingress buffer fill level. Since this is a real-time register, the value read from it will change rapidly and is used for internal diagnostics only.

SPI-4 ingress max fill level register (Block_base 0x0300 + Register_offset 0x0B - 0x0C)

TABLE 96 - SPI-4 INGRESS MAX FILL LEVEL REGISTER (0x0B and 0x0C)

Field	Bits	Length	Initial Value
FILL_MAX	5:0	6	0x00

There is one register for SPI-4 ingress max fill level register per SPI-3 interface at Block_base 0x0300. Each register has read-only access, and is cleared after reading. 0x20 is the highest filling level, meaning all ingress buffers on a PFP had been full at some time since the last read of the FILL_MAX field. The units of FILL_MAX are one-thirty-second of the available ingress buffering per PFP. Each unit is equal to 128 bytes.

The SPI-4 ingress max fill level register for PFP A is at Block_base 0x0300 + Register_offset 0x0B.

The SPI-4 ingress max fill level register for PFP B is at Block_base 0x0300 + Register_offset 0x0C.

The bit field of a SPI-4 ingress max fill level register is described.

FILL_MAX Maximum SPI-4 ingress buffer fill level since the last read of the SPI-4 ingress max fill level register.

SPI-4 ingress diagnostics register (Block_base 0x0300 + Register_offset 0x0F)

TABLE 97 - SPI-4 INGRESS DIAGNOSTICS REGISTER (REGISTER_OFFSET 0x0F)

Field	Bits	Length	Initial Value
I_FORCE_TRAIN	0	1	0
I_ERR_INS	1	1	0
I_DIP_NUM	5:2	4	0

The SPI-4 ingress Diagnostics Register is addressed from Block_base 0x0300 + Register_offset 0x0F. The SPI-4 ingress Diagnostics Register has read and write access. The SPI-4 ingress Diagnostics Register is used in port diagnostics to force continuous training on the SPI-4 ingress status interface,

insert a DIP-2 error on the SPI-4 ingress status interface, and read the number of DIP-2 errors seen on the SPI-4 egress status interface.

I_FORCE_TRAIN The I_FORCE_TRAIN field is used to force continuous training on the SPI-4 ingress status interface.
 0=Normal status channel operation
 1=Force continuous training on the SPI-4 ingress status interface

I_ERR_INS The I_ERR_INS field is used to insert the number of DIP-2 errors on the SPI-4 ingress status interface programmed into the I_DIP_NUM field. After the DIP-2 errors are inserted, the I_ERR_INS field will clear itself.
 0=Normal status channel operation
 1=Insert DIP-2 errors on the SPI-4 ingress status interface

I_DIP_NUM
 The I_DIP_NUM field is used to create the number of DIP-2 errors programmed into the I_DIP_NUM field on the SPI-4 egress status interface..

SPI-4 ingress DIP-4 error counter (Block_base 0x0300 + Register_offset 0x10)

TABLE 98 - SPI-4 INGRESS DIP-4 ERROR COUNTER (REGISTER_OFFSET 0x10)

Field	Bits	Length	Initial Value
DIP_4	15:0	16	0

The SPI-4 ingress DIP-4 error counter is addressed from Block_base 0x0300 + Register_offset 0x10. The SPI-4 ingress DIP-4 error counter has read access, and automatically clears itself after a read. The SPI-4 ingress DIP-4 error counter is used in port diagnostics to verify the integrity of the SPI-4 ingress data path.

DIP_4 The DIP_4 field is used to read the number of DIP-4 errors seen on the SPI-4 egress status interface. The DIP_4 field saturates at the value 0xFFFF, and is automatically cleared after reading to re-start DIP-4 error counter accumulation.

SPI-4 ingress bit alignment control register (Block_base 0x0300 + Register_offset 0x11)

TABLE 99 - SPI-4 INGRESS BIT ALIGNMENT CONTROL REGISTER (REGISTER_OFFSET 0x11)

Field	Bits	Length	Initial Value
FORCE	0	1	0

The SPI-4 ingress bit alignment control register is addressed from Block_base 0x0300 + Register_offset 0x11. The SPI-4 ingress bit alignment control register has read and write access. The SPI-4 ingress bit alignment control register is used to overrule the automatically selected bit phase alignments and go to manual mode. In manual mode, the PHASE_ASSIGN field [Block_base 0x0800 + Register_offset 0x0c - 0x1f] now defines the selected phase.

FORCE The FORCE field is used to manually align the SPI-4 ingress data.
 0=Normal bit alignment operation
 1=Force to manual bit alignment mode on SPI-4 ingress data using the PHASE_ASSIGN field.

SPI-4 ingress start up training threshold register (Block_base 0x0300 + Register_offset 0x12)

TABLE 100 - SPI-4 INGRESS START UP TRAINING THRESHOLD REGISTER (REGISTER_OFFSET 0x12)

Field	Bits	Length	Initial Value
STRT_TRAIN	7:0	8	0

The SPI-4 ingress start up training threshold register is addressed from Block_base 0x0300 + Register_offset 0x12. The SPI-4 ingress start up training threshold register has read and write access. The SPI-4 ingress start up training threshold register is used to set the number of consecutive training patterns that will lead to OUT_OF_SYNC on the SPI-4 ingress data. If the STRT_TRAIN field is set to zero, then the OUT_OF_SYNC feature is disabled.

STRT_TRAIN The STRT_TRAIN field is used to set the number of consecutive training patterns that will lead to OUT_OF_SYNC on the SPI-4 ingress data interface.

9.4.5 Common module block base 0x0400 registers SPI-4 egress LID to LP map (Block_base 0x0400 + Register_offset 0x00 - 0x7F)

TABLE 101 - SPI-4 EGRESS LID TO LP MAP (128 ENTRIES)

Field	Bits	Length	Initial Value
LP	7:0	8	0x00
EN	8	1	0b0

There are 128 entries in the SPI-4 egress LID to LP map for the SPI-4 ingress interface. The entries are at Block_base 0x0400 + LID. For example, LID 0x00 is at Block_base 0x0400 + 0x00. A SPI-4 egress LID to LP map has read and write access. A SPI-4 egress LID to LP map is used to map a logical identifier used internally to a SPI-4 egress logical port.

- 0x00 - 0x3F of the LID map is used for Module A LIDs 0x00 - 0x3F
- 0x40 - 0x7F of the LID map is used for Module B LIDs 0x40 - 0x7F

Data for an inactive LP having an entry in the calendar is forwarded to LID0. Therefore all the LPs that have entries in the calendar tables should be enabled.

LP The LP programmed is associated to the LID with the same number as the register address. Eight bits support the 256 possible LPs on the SPI-4 physical interface. Only 128 LPs can be supported at one time with the IDT88P8342 device.

EN The EN bit is used to enable or disable the connection of a LID to an LP.
 0=LP is disabled
 1=LP is enabled

9.4.6 Common module block base 0x0500 registers SPI-4 egress calendar_0 (Block_base 0x0500 + Register_offset 0x00 - 0xFF)

TABLE 102 - SPI-4 EGRESS CALENDAR_0 (256 LOCATIONS)

Field	Bits	Length	Initial Value
LP	7:0	8	0xFF

The SPI-4 egress calendar_0 is at Block_base 0x0500 and has read and write access. When the SPI-4 egress calendar_0 is selected, calendar_0 is in use. There are 256 entries in the SPI-4 egress calendar_0 to schedule the updating of the FIFO status channel LPs to the attached device. If less than the

maximum 256 LPs are needed on the SPI-4 interface, the calendar entries should be used for scheduling more frequent status updated for higher-speed LPs. The value of time-critical LPs must appear multiple times in the table. For example, a multi-PHY SPI-4 could have OC-48 channels appear in the calendar at four times the rate of OC-12 channels, since the higher data rate of the OC-48 channels would benefit from more frequent FIFO status channel updates. The LP field values range from 0x00 to 0xFF. The IDT88P8342 and the attached devices must have identical calendars.

LP The LP value programmed schedules a status channel update according to the calendar sequence.

**9.4.7 Common module block base 0x0600 registers
SPI-4 egress calendar_1 (Block_base 0x0600 + Register_offset 0x00 – 0xFF)**

TABLE 103 - SPI-4 EGRESS CALENDAR_1 (256 LOCATIONS)

Field	Bits	Length	Initial Value
LP	7:0	8	0xFF

The SPI-4 egress calendar_1 is at Block_base 0x0600 and had read and write access. When the SPI-4 egress calendar_1 is selected, calendar_1 is in use. There are 256 entries in the SPI-4 egress calendar_1 to schedule the updating of the FIFO status channel LPs to the attached device. If less than the maximum 256 LPs are needed on the SPI-4 interface, the calendar entries should be used for scheduling more frequent status updated for higher-speed LPs. The value of time-critical LPs must appear multiple times in the table. For example, a multi-PHY SPI-4 could have OC-48 channels appear in the calendar at four times the rate of OC-12 channels, since the higher data rate of the OC-48 channels would benefit from more frequent FIFO status channel updates. The LP field values range from 0x00 to 0xFF. The IDT88P8342 and the attached devices must have identical calendars.

LP The LP value programmed schedules a status channel update according to the calendar sequence.

**9.4.8 Common module block base 0x0700 registers
SPI-4 egress configuration register_0 (Block_base 0x0700 + Register_offset 0x00)**

TABLE 104 – SPI-4 EGRESS CONFIGURATION REGISTER_0 (REGISTER_OFFSET 0x00)

Field	Bits	Length	Initial Value
Reserved	2:0	3	0
E_CLK_EDGE	3	1	0
E_DSC	4	1	0
E_INSYNC_THR	9:5	5	0x1F
E_OUTSYNC_THR	13:10	4	0xF
E_CSW_EN	14	1	0
Reserved	15	1	0
E_LOW	16	1	1
NOSTAT	17	1	0

The SPI-4 egress configuration register_0 is at Block_base 0x0700 and has read and write access.

The SPI-4 egress configuration register_0 is used to set the state of the SPI-4 egress interface. The bit fields of the SPI-4 egress configuration register_0 are described.

E_CLK_EDGE The SPI-4 egress clock active clock edge is selected using the E_CLK_EDGE field.

- 0=SPI-4 egress clock uses the rising clock edge
- 1=SPI-4 egress clock uses the falling clock edge

E_DSC The E_DSC bit enables or disables de-skewing of the SPI-4 egress data lines.

- 0=Data de-skewing is disabled
- 1=Data de-skewing is enabled (recommended)

E_INSYNC_THR The SPI-4 egress DIP-2 in-synchronization threshold is controlled using the E_INSYNC_THR field. It is recommended to use the initial value.

E_OUTSYNC_THR The SPI-4 egress DIP-2 out-of-synchronization threshold is controlled using the E_OUTSYNC_THR field. It is recommended to use the initial value.

E_CSW_EN The ingress calendar switch enable bit is used to enable the switching of the active calendars following the reception of the calendar selection word on the status channel. It is recommended to use the initial value.

- 0=Egress calendar switch is disabled. Only SPI-4 egress calendar_0 is used.
- 1=Egress calendar switch is enabled. Calendar_0 or calendar_1 will be used.

E_LOW The E_LOW field selects the SPI-4 egress clock frequency range.

- 0=SPI-4 egress clock is greater than or equal to 200 MHz
- 1=SPI-4 egress clock is less than 200 MHz

NOSTAT The NOSTAT bit enables the no status channel option. Once NOSTAT is set, the status channel is ignored. There is no DIP-2 error checking, and no status channel updating. The received status is fixed to starving. The data channel is put into the IN_SYNC state.

- 0=Normal status channel operation
- 1=No status channel option is selected

SPI-4 egress configuration register_1 (Block_base 0x0700 + Register_offset 0x01)

TABLE 105 - SPI-4 EGRESS CONFIGURATION REGISTER_1 (REGISTER_OFFSET 0x01)

Field	Bits	Length	Initial Value
DATA_MAX_T	23:0	24	0
ALPHA	31:24	8	0

The SPI-4 egress configuration register_1 is at Block_base 0x0700 and has read and write access.

The SPI-4 egress configuration register_1 is used to set the state of the SPI-4 egress FIFO status path interface. The bit fields of the SPI-4 egress configuration register_1 are described.

DATA_MAX_T The SPI-4 egress DATA_MAX_T field is the maximum time interval between scheduling of training sequences on the egress data path interface. The purpose of the data training interval is to allow the de-skewing of plus or minus one bit time on the egress data interface if needed. The time is set for the DATA_MAX_T field multiplied by 128 cycles.

ALPHA The SPI-4 egress ALPHA field is the number of repetitions of the data training sequence that must be scheduled every DATA_MAX_T cycles. The value for alpha used is actually one more than the ALPHA value programmed into the ALPHA field.

SPI-4 egress status register (Block_base 0x0700 + Register_offset 0x02)

TABLE 106 - SPI-4 EGRESS STATUS REGISTER (REGISTER_OFFSET 0x02)

Field	Bits	Length	Initial Value
E_SYNCH	0	1	0
E_DSK_OOR	1	1	0
SCLK_AV	2	1	0

SPI-4 egress status register
The SPI-4 egress status register is at Block_base 0x0700 and has read-only access.

The SPI-4 egress status register is used to set the state of the SPI-4 egress synchronization.

The bit fields of the SPI-4 egress status register are described.

E_SYNCH The SPI-4 egress E_SYNCH field describes the synchronization state of the SPI-4 egress data path.

- 0=SPI-4 egress data path is out of synchronization
- 1=SPI-4 egress data path is in synchronization

E_DSK_OOR The SPI-4 egress E_DSK_OOR field describes the de-skew state of the SPI-4 egress data path.

- 0=SPI-4 egress data path de-skew is within range
- 1=SPI-4 egress data path de-skew is out of range

SCLK_AV The SPI-4 egress SCLK_AV field describes the availability state of the SPI-4 egress status channel clock. This function is not available if SCLK < 0.5 MCLK.

- 0=SPI-4 egress status channel clock is not available
- 1=SPI-4 egress status channel clock is available

SPI-4 egress calendar configuration register (Block_base 0x0700 + Register_offset 0x03 - 0x04)

TABLE 107 - SPI-4 EGRESS CALENDAR CONFIGURATION REGISTER (REGISTER_OFFSET 0x03 - 0x04)

Field	Acc	Bits	Length Value	Initial
E_CAL_M	RW	7:0	8	0
E_CAL_LEN	RW	13:8	6	0x01

The SPI-4 egress calendar configuration registers are at Block_base 0x0300 and has read and write access. The Register_offset for calendar_0 is 0x03. The register offset for calendar_1 is 0x04.

The bit fields of the SPI-4 egress calendar configuration register are described.

The IDT88P8342 calendar length can be programmed to any multiple of 4 using suitable values for the calendar entries, calendar length and calendar M. If the adjacent device is unable to configure its calendar to be a multiple of 4, conversion logic may be needed between the adjacent device SPI-4 status signals and the 88P8342 signals.

E_CAL_M The E_CAL_M value programmed defines the number of times the calendar sequence is repeated before a DIP-2 parity and "1" framing words are inserted. The actual calendar_M value used is one more than the value programmed into the E_CAL_M field.

E_CAL_LEN The E_CAL_LEN value programmed defines the length of the SPI-4 egress calendar. The actual length of the calendar is four times one more than the value programmed into the E_CAL_LEN field. For example, if the E_CAL_LEN field is programmed to 0x3F, the actual value used is 0x100. The calendar length must be at least as large as the number of active SPI-4 egress LPs.

SPI-4 egress diagnostics register (Block_base 0x0700 + Register_offset 0x05)

TABLE 108 - SPI-4 EGRESS DIAGNOSTICS REGISTER (REGISTER_OFFSET 0x05)

Field	Bits	Length Value	Initial
E_FORCE_TRAIN	0	1	0
E_ERR_INS	1	1	0
E_DIP_NUM	5:2	4	0
BIT_DELAY	7:6	2	0

The SPI-4 egress diagnostics register is addressed from Block_base 0x0700 + Register_offset 0x05. The SPI-4 egress diagnostics register has read and write access.

E_FORCE_TRAIN The E_FORCE_TRAIN field is used to force continuous training on the SPI-4 egress status interface.

- 0=Normal status channel operation
- 1=Force continuous training on the SPI-4 egress status interface

E_ERR_INS The E_ERR_INS field is used to insert the number of DIP-4 errors on the SPI-4 egress data interface that have been programmed into the E_DIP_NUM field. After the DIP-4 errors are inserted, the E_ERR_INS field will clear itself.

- 0=Normal status channel operation
- 1= Insert DIP-4 errors on the SPI-4 egress data interface

E_DIP_NUM The E_DIP_NUM field is used to create DPI-4 errors on the SPI-4 egress data interface. The number of errors generated is equal to the value of the E_DIP_NUM field.

BIT_DELAY The BIT_DELAY field is used to delay SPI-4 egress data bit line 0 by the number of bits programmed into the BIT_DELAY field. This may be used for diagnostics.

SPI-4 egress DIP-2 error counter (Block_base 0x0700 + Register_offset 0x06)

TABLE 109 - SPI-4 EGRESS DIP-2 ERROR COUNTER (REGISTER_OFFSET 0x06)

Field	Bits	Length	Initial Value
DIP_2	15:0	16	0

The SPI-4 egress DIP-2 error counter is addressed from Block_base 0x0700 + Register_offset 0x06. The SPI-2 egress DIP-2 error counter has read access, and automatically clears itself after a read. The SPI-4 egress DIP-2 error counter is used in port diagnostics to verify the integrity of the SPI-4 egress status channel.

DIP_2 The DIP_2 field is used to read the number of DIP-2 errors seen on the SPI-4 egress status interface. The DIP_2 field saturates at the value 0xFFFF, and is automatically cleared after reading to re-start DIP-2 error counter accumulation.

9.4.9 Common module block base 0x0800 registers
SPI-4 ingress bit alignment window register
(Block_base 0x0800 + Register_offset 0x00)

TABLE 110 - SPI-4 INGRESS BIT ALIGNMENT WINDOW REGISTER (REGISTER_OFFSET 0x00)

Field	Bits	Length	Initial Value
W	15:0	16	0xFFFF

The SPI-4 ingress bit alignment window register is addressed from Block_base 0x0800 + Register_offset 0x00. The SPI-4 ingress bit alignment window register has read and write access. The SPI-4 ingress bit alignment window register is used in manual bit alignment procedures and it is recommended to leave the W field at its initial value.

W The W field is used to define the width of the SPI-4 ingress bit alignment observation window by setting the time between bit alignment operations. .

SPI-4 ingress lane measure register (Block_base 0x0800 + Register_offset 0x01)

TABLE 111 - SPI-4 INGRESS LANE MEASURE REGISTER (REGISTER_OFFSET 0x01)

Field	Bits	Length	Initial Value
LANE	4:0	5	0
Reserved	7:5	3	0
MEASURE_BUSY	8	1	0

The SPI-4 ingress lane measure register is addressed from Block_base 0x0800 + Register_offset 0x01. The SPI-4 ingress lane measure register has read and write access. SPI-4 ingress lane measure register is used in manual bit alignment procedures and it is recommended to leave the SPI-4 ingress lane measure register at its initial value.

LANE The LANE field is used to manually control the measurement of SPI-4 ingress data lane alignment. The LANE field is intended for diagnostics only and is not needed in normal operation.

- 0=DATA0 lane selected for measurement
- x=DATAx lane selected for measurement
- 15=DATA15 lane selected for measurement
- 16=CTL selected for measurement
- 17=Egress status 0 selected for measurement
- 18=Egress status 1 selected for measurement
- 19=Chip test feature not available for diagnostics

MEASURE_BUSY The MEASURE_BUSY field is used to observe when the LANE process is busy for manual lane assignment procedures. The MEASURE_BUSY field is intended for diagnostics only and is not needed for normal operation.

- 0=Normal operation
- 1=Lane process is busy

SPI-4 ingress bit alignment counter register
(Block_base 0x0800 + Register_offset 0x02 – 0x0B)

TABLE 112 - SPI-4 INGRESS BIT ALIGNMENT COUNTER REGISTER (0x02 to 0x0B)

Field	Bits	Length	Initial Value
C[n]	9:0	10	0

The SPI-4 ingress bit alignment counter registers at Block_base 0x0800 are read-only and contains the values of the bit alignment counters used for manual lane alignment. The registers are intended for diagnostics only and are not needed in normal operation.

SPI-4 ingress manual alignment phase/result register (Block_base 0x0800 + Register_offset 0x0C – 0x1F)

TABLE 113 - SPI-4 INGRESS MANUAL ALIGNMENT PHASE/RESULT REGISTER (0x0C to 0x1F)

Field	Bits	Length	Initial Value
PHASE_ASSIGN	7:0	8	0

The SPI-4 ingress manual alignment phase/result registers at Block_base 0x0800 have read and write access. A SPI-4 ingress manual alignment phase/result register is used to manually align the phase of the data lane, control lane, status lanes, and a test lane corresponding to its register in turn and is intended for diagnostics only and is not needed in normal operation. If the FORCE field of Table 99, SPI-4 ingress bit alignment control register (register_offset 0x11) is set to a logic one, manual phase alignment is enabled. If the FORCE field is set to a logic zero, normal automatic phase alignment is enabled, and the result can be viewed here. There are five center taps to choose from, plus two guard taps on either side of the center, per data bit sampled. The oldest data sample is at tap 8 ("right"), while the newest data sample is at tap 0 ("left"). Taps 0 and 1 are the left margin taps for tracking purposes, while taps 7 and 8 are the right margin taps. A tap between 2 to 7 is initially selected in automatic mode. See Figure 7-Data sampling diagram. Register 0x0C is used for lane DATA0.

PHASE_ASSIGN [3:0]

Used for selecting the bit phase corresponding to the rising clock edge of I_DCLK. The four bits number the phases from 0 to 8, relative to the positively-clocked bit.

PHASE_ASSIGN [7:4]

Used for selecting the bit phase corresponding to the falling clock edge of I_DCLK. The four bits number the phases from 0 to 8, relative to the negatively-clocked bit.

SPI-4 egress data lane timing register (Block_base 0x0800 + Register_offset 0x2A)

TABLE 114 - SPI-4 EGRESS DATA LANE TIMING REGISTER (REGISTER_OFFSET 0x2A)

Field	Bits	Length	Initial Value
DTC0[1:0]	1:0	2	0
DTC1[1:0]	3:2	2	0
...	..	2	0
DTC15[1:0]	31:30	2	0

The SPI-4 egress data lane timing register at Block_base 0x0800 + Register_offset 0x2A has read and write access. The SPI-4 egress data lane timing register is used to manually align the phase of data lane n by adding from 0.1 clock cycle to 0.3 clock cycles of delay.

DTCn [1:0] Used for adding 0.1 clock cycles of output delay to SPI-4 egress data lane n.

- [1:0]=0=No added delay
- [1:0]=1=Add 0.1 clock cycle of delay to data lane n

- [1:0]=2=Add 0.2 clock cycles of delay to data lane n
- [1:0]=3=Add 0.3 clock cycles of delay to data lane n

SPI-4 egress control lane timing register (Block_base 0x0800 + Register_offset 0x2B)

TABLE 115 - SPI-4 EGRESS CONTROL LANE TIMING REGISTER (REGISTER_OFFSET 0x2B)

Field	Bits	Length	Initial Value
CTLTC[1:0]	1:0	2	0

The SPI-4 egress control lane timing register at Block_base 0x0800 has read and write access. The SPI-4 egress control lane timing register is used to manually align the phase of the control lane by adding from 0.1 clock cycle to 0.3 clock cycles of delay.

CTLTC [1:0] Used for adding 0.1 clock cycles of output delay to the SPI-4 egress control output.

- [1:0]=0=No added delay
- [1:0]=1=Add 0.1 clock cycle of delay to the control output
- [1:0]=2=Add 0.2 clock cycles of delay to the control output
- [1:0]=3=Add 0.3 clock cycles of delay to the control output

SPI-4 egress data clock timing register (Block_base 0x0800 + Register_offset 0x2C)

TABLE 116 - SPI-4 EGRESS DATA CLOCK TIMING REGISTER (REGISTER_OFFSET 0x2C)

Field	Bits	Length	Initial Value
DCTC[3:0]	3:0	4	0

The SPI-4 egress data clock timing control register at Block_base 0x0800 has read and write access. The SPI-4 egress data clock timing control register is used to manually align the phase of the SPI-4 egress data clock to the data and control lanes by adding from 0.1 clock cycle to 0.9 clock cycles of delay to the data clock. Note that tap selection is not monotonic with the number in bit field [3:0].

DCTC [3:0] Used for adding 0.1 clock cycles of output delay to the SPI-4 egress data clock.

- [3:0]=0=No added delay
- [3:0]=1=Add 0.1 clock cycle of delay to the SPI-4 egress data clock
- [3:0]=3=Add 0.2 clock cycles of delay to the SPI-4 egress data clock
- [3:0]=2=Add 0.3 clock cycles of delay to the SPI-4 egress data clock
- [3:0]=7=Add 0.4 clock cycles of delay to the SPI-4 egress data clock
- [3:0]=6=Add 0.5 clock cycles of delay to the SPI-4 egress data clock
- [3:0]=4=Add 0.6 clock cycles of delay to the SPI-4 egress data clock
- [3:0]=5=Add 0.7 clock cycles of delay to the SPI-4 egress data clock
- [3:0]=F=Add 0.8 clock cycles of delay to the SPI-4 egress data clock
- [3:0]=E=Add 0.9 clock cycles of delay to the SPI-4 egress data clock

SPI-4 egress status timing register (Block_base 0x0800 + Register_offset 0x2D)

TABLE 117 - SPI-4 EGRESS STATUS TIMING REGISTER (REGISTER_OFFSET 0x2D)

Field	Bits	Length	Initial Value
STC0[1:0]	1:0	2	0
STC1[1:0]	3:2	2	0

The SPI-4 egress status timing register at Block_base 0x0800 + Register_offset 0x2D has read and write access. The SPI-4 egress status timing register is used to manually align the phase of the status lane n by adding from 0.1 clock cycle to 0.3 clock cycles of delay. The STC0[1:0] and STC1[1:0] fields are valid only for LVDS status, not for LVTTTL status.

STCn [1:0] Used for adding 0.1 clock cycles of output delay to SPI-4 egress status lane n.

- [1:0]=0=No added delay
- [1:0]=1=Add 0.1 clock cycle of delay to status lane n
- [1:0]=2=Add 0.2 clock cycles of delay to status lane n
- [1:0]=3=Add 0.3 clock cycles of delay to status lane n

SPI-4 egress status clock timing register (Block_base 0x0800 + Register_offset 0x2E)

TABLE 118 - SPI-4 EGRESS STATUS CLOCK TIMING REGISTER (REGISTER_OFFSET 0x2E)

Field	Bits	Length	Initial Value
SCTC[3:0]	3:0	4	0

The SPI-4 egress status clock timing register at Block_base 0x0800 + Register_offset 0x2E has read and write access. The SPI-4 egress status clock timing register is used to manually align the phase of the SPI-4 egress status clock to the status outputs by adding from 0.1 clock cycle to 0.9 clock cycles of delay to the status clock output. Note that tap selection is not monotonic with the number in bit field [3:0].

SCTC [3:0] Used for adding 0.1 clock cycles of output delay to the SPI-4 egress status clock output.

- [3:0]=0=No added delay
- [3:0]=1=Add 0.1 clock cycle of delay to the SPI-4 egress status clock
- [3:0]=3=Add 0.2 clock cycles of delay to the SPI-4 egress status clock
- [3:0]=2=Add 0.3 clock cycles of delay to the SPI-4 egress status clock
- [3:0]=7=Add 0.4 clock cycles of delay to the SPI-4 egress status clock
- [3:0]=6=Add 0.5 clock cycles of delay to the SPI-4 egress status clock
- [3:0]=4=Add 0.6 clock cycles of delay to the SPI-4 egress status clock
- [3:0]=5=Add 0.7 clock cycles of delay to the SPI-4 egress status clock
- [3:0]=F=Add 0.8 clock cycles of delay to the SPI-4 egress status clock
- [3:0]=E=Add 0.9 clock cycles of delay to the SPI-4 egress status clock

9.4.10 Common module block base 0x0900 registers

PMON timebase control register (Block_base 0x0900 + Register_offset 0x00)

TABLE 119 - PMON TIMEBASE CONTROL REGISTER (REGISTER_OFFSET 0x00)

Field	Bits	Length	Initial Value
INTERNAL	0	1	0b0
TIMER	1	1	0b0
MANUAL	2	1	0b0

A single PMON timebase module is available in the IDT88P8344. The PMON timebase module directs a timebase event to all PMON modules in the device. The timebase period can be internally or externally generated. The selection is made by the INTERNAL flag in the PMON update control register. A snapshot of the counters is taken when the timebase expires and the counters are cleared. The PMON update control register is at common module 0x8000 + Block_base 0x0900 + Register_offset 0x00 = 0x8900 and has read and write access.

INTERNAL Selects between internal or external timebases for performance monitoring. The internal timebase is either generated by the internal processor or by a free running timer. The selection is made by the TIMER flag in the PMON update control register. When the time interval expires, the TIMEBASE pin is asserted for sixteen MCLK cycles. The timebase event is captured by the timebase status in the support interrupt status register.

0= External timebase from the TIMEBASE pin is selected. The externally generated timebase signal is applied to the TIMEBASE pin. A positive edge detector generates the timebase event.

1=Internal timebase is selected. When the time interval expires, the TIMEBASE pin is driven high for sixteen MCLK cycles.

TIMER Selects between the internal free-running timebase or a microprocessor-controlled write to generate the timebase event. The TIMER field is valid only when the INTERNAL field is a logic one.

- 0=Selects the microprocessor generated timebase
- 1=Selects the internal free-running timebase

MANUAL The microprocessor generates an internal timebase event by a write access with a logical one to the MANUAL flag in the PMON Update Control Register if the microprocessor timebase is selected. The MANUAL bit is self-clearing. The MANUAL field is only valid if the TIMER field is a logic zero.

- 0=No operation
- 1=A timebase event is generated

Timebase register (Block_base 0x0900 + Register_offset 0x01)

TABLE 120 - TIMEBASE REGISTER (REGISTER_OFFSET 0x01)

Field	Bits	Length	Initial Value
PERIOD	26:0	27	0x4A2 8600

The timebase register is at Block_base 0x0900 + Register_offset 0x01 and has read and write access.

The timebase period for free-running timers is configured by the PERIOD field in the timebase register. The PERIOD field specifies the number of MCLK clock cycles required for a single event. The PERIOD field is only valid if both the INTERNAL and TIMER fields are a logic one.

Clock generator control register (Block_base 0x0900 + Register_offset 0x010)

TABLE 121 - CLOCK GENERATOR CONTROL REGISTER (REGISTER_OFFSET 0x10)

Field	Bits	Length	Initial Value
OCLK0_EN	0	1	0b01
N_OCLK0	2:1	2	0b11
Reserved	3	1	0b0
OCLK1_EN	4	1	0b1
N_OCLK1	6:5	2	0b11
Reserved	7	1	0b0
OCLK2_EN	8	1	0b1
N_OCLK2	10:9	2	0b11
Reserved	11	1	0b0
OCLK3_EN	12	1	0b1
N_OCLK3	14:13	2	0b11
Reserved	16:15	2	0b0
N_MCLK	18:17	2	0b11
Reserved	31:19	13	0

The clock generator control register is at common module Block_base 0x0900 + Register_offset 0x010.

The clock generator provides four clock outputs on the OCLK[3:0] pins, MCLK for internal use, and SPI-4 data and FIFO status channel egress clocks. The OCLK[3:0] clock frequencies can be selected independently of each other. OCLK[3:0] outputs can be used as SPI-3 clock sources. The OCLK[3:0] pins are separately enabled by setting each associated enable flag in Table 121 - Clock generator control register (Register_offset 0x10). When an OCLK[3:0] output is not enabled, it is in a logic low state. MCLK is the internal processing clock, and is always enabled. Refer to Table 122 - OCLK and MCLK frequency select encoding, for selecting the frequencies of MCLK and OCLKs.

During either a hardware or a software reset, the OCLK[3:0] pins are all logic low. Immediately following reset, all OCLK[3:0] outputs are active with the output frequency defined by pll_ockl divided by the initial value in the Table 121 - Clock generator control register (Block_base 0x0900 + Register_offset 0x10).

The clock generator control register at indirect address 0x8910 has read and write access. The clock generator control register is used to set the frequency of MCLK and the OCLK outputs, as well as to enable the OCLK outputs. Note that divider values should be chosen so that OCLK[3:0] and MCLK are within their specified operating range provided in Table 136, OCLK[3:0] clock outputs and MCLK internal clock.

OCLK[k]_EN Used for enabling the kth OCLK output
 0=OCLK[k] is not enabled and OCLK[k] is at a logic zero
 1=OCLK[k] is enabled and active

N_OCLK[k][1:0] Select the OCLK[k] frequency according to Table 122-OCLK and MCLK frequency select encoding.

N_MCLK[k] Select the MCLK frequency according to Table 122-OCLK and MCLK frequency select encoding.

TABLE 122 - OCLK AND MCLK FREQUENCY SELECT ENCODING

N_MCLK & N_OCLK[k] Frequency Selects	Frequency
00	pll_ockl / 4
01	pll_ockl / 6
10	pll_ockl / 8
11	pll_ockl / 10

General purpose I/O (Block_base 0x0900 + Register_offset 0x20)

TABLE 123 - GPIO REGISTER (REGISTER_OFFSET 0x20)

Field	Bits	Length	Initial Value
DIR_OUT	4:0	5	0x00
Reserved	7:5	3	0x0
LEVEL	12:8	5	0x00
Reserved	15:13	3	0x0
MONITOR_EN	20:16	5	0x00

Five general purpose I/O pins are provided. Each pin I/O direction is controlled by the DIR_OUT field in the GPIO register. The logical level on a GPIO pin is controlled by the LEVEL field in the GPIO register if DIR_OUT=1 (pin=output), or sensed if DIR_OUT=0 (pin=input). Optionally, the LEVEL bit can monitor the logic level of any bit selected from the indirect access space if MONITOR_EN is set high. With MONITOR_EN set high, bits in the indirect access space can be selected for monitoring by the ADDRESS and BIT fields in the GPIO monitor table.

The general purpose I/O registers are at common module Block_base 0x0900 and have read and write access.

DIR_OUT[4:0] Used for configuring each GPIO pin as either an input or an output

- 0=GPIO pin is an input
- 1=GPIO pin is an output

LEVEL[4:0] Used for sensing or driving each GPIO pin
0=GPIO pin is sensed as a logic zero if an input, or driven to a logic zero if an output

1=GPIO pin is sensed as a logic one if an input, or driven to a logic one if an output

MONITOR_EN [4:0] Used for enabling the monitor output function for each GPIO pin. GPIO pins used as monitors must also be configured to be outputs. All GPIO pins must be used as either monitors or as normal I/O; no mixing of the monitoring function and the normal I/O function is permitted.

- 0=GPIO pin is used as an I/O pin
- 1=GPIO pin is used as a monitor pin

GPIO monitor table (Block_base 0x0900 + Register_offset 0x21 - 0x25)

TABLE 124 - GPIO MONITOR TABLE (5 ENTRIES 0x21-0x25 FOR GPIO[0] THROUGH GPIO[4])

Field	Bits	Length	Initial Value
ADDRESS	15:0	16	0x0000
Reserved	23:16	8	0x00
BIT	28:24	5	0x00
Reserved	31:29	3	0x0

A bit in the indirect access space can be selected for monitoring by the ADDRESS and BIT fields in the GPIO monitor table.

The GPIO Monitor Table for GPIO[0] is at Common_Module 0x8000+ Block_base 0x900 + Register_offset 0x21 = 8x8921.

The GPIO Monitor Table for GPIO[1] is at Common_Module 0x8000+ Block_base 0x0900 + Register_offset 0x22 = 0x8922.

The GPIO Monitor Table for GPIO[2] is at Common_Module 0x8000+ Block_base 0x0900 + Register_offset 0x23 = 0x8923.

The GPIO Monitor Table for GPIO[3] is at Common_Module 0x8000+ Block_base 0x0900 + Register_offset 0x24 = 0x8924.

The GPIO Monitor Table for GPIO[4] is at Common_Module 0x8000+ Block_base 0x0900 + Register_offset 0x25 = 0x8925.

ADDRESS[15:0] Used for configuring the indirect address select when the GPIO pins are put into monitor mode.

BIT[4:0] Used for selecting the register bit (1 of 32) for a GPIO put into monitor mode.

BIT[4:0]=0x00 selects data bit 0.

...

BIT[4:0]=0x1F selects data bit 31.

Version number register (common module Block_base 0x0900 + Register_offset 0x30)

TABLE 125 - VERSION NUMBER REGISTER (REGISTER_OFFSET 0x30)

Field	Bits	Length	Initial Value
Version	7:0	8	0x01
ID	15:8	8	0xF8

The version number register is a read-only sixteen-bit register at Common_module 0x8000 + Block_base 0x0900 + Register_offset 0x30 = 0x8930 in the indirect register access space. The version number register contains hard-coded values that can be read to verify the microprocessor read path is correct, and that the correct part is installed.

VERSION The hardware version is read from this field.

ID The hardware identification is read from this field.

10. JTAG INTERFACE

The device supports the optional TRST input signal. It supports a TCK clock frequency up to 10MHz.

TABLE 126 – JTAG INSTRUCTIONS

Code	Instruction	Function
000	EXTEST	JTAGfunction
001	IDCODE	JTAGfunction
010	SAMPLE	JTAGfunction
011	CLAMP	JTAGfunction
100	HIGHZ	JTAGfunction
101	Private	Privatefunction
111	BYPASS	JTAGfunction

Version field equals 0

JTAG ID #0x044E MANUFACTURER ID 0x033 LAST BIT IS 1.

11. ELECTRICAL AND THERMAL SPECIFICATIONS

11.1 Absolute maximum ratings

TABLE 127 – ABSOLUTE MAXIMUM RATINGS

Parameter	Symbol	Conditions	Min. ⁽¹⁾	Max. ⁽¹⁾	Unit
Core Digital Supply Voltage	VDDC18	VSS=0, AVSS=0, Tj=25°C	-0.3	2.2	V
I/O Digital Supply Voltage	VDDT33		-0.3	4.6	V
Analog Supply Voltage	VDDA18		-0.3	3.6	V
Analog Supply Voltage	VDDA33		-0.3	3.6	V
I/O Input Voltage for CMOS	VinL		-0.5	6.0	V
I/O Input Voltage for LVTTTL	VinL		-0.5	6.0	V
I/O Output Voltage	Vout		-0.5	4.6	V
Latch-up Current	Io		-	100	mA
ESD Performance (HBM)			-	2000	V
Ambient Operating Temperature	Ta(Industrial)		-40	+85	°C
Ambient Operating Temperature	Ta(Commercial)		0	+70	°C
Storage Temperature	Ts		-65	+150	°C

NOTE:

1. Functional and tested operating conditions are given in Table Absolute Maximum Ratings are stress ratings only, and functional operation at the maximum is not guaranteed. Stresses beyond those listed may affect device reliability or cause permanent damage to the device.

11.2 Recommended Operating Conditions

TABLE 128 – RECOMMENDED OPERATING CONDITIONS

Parameter	Symbol	Conditions	Min.	Typ.	Max.	Unit
Core Digital Supply Voltage	VDDC18	VSS=0	1.68	1.8	1.96	V
I/O Digital Supply Voltage	VDDT33	VSS=0	3.0	3.3	3.6	V
Analog Supply Voltage	VDDA18	VSS=0	1.68	1.8	1.96	V
Analog Supply Voltage	VDDA33	VSS=0	3.0	3.3	3.6	V
Ambient Operating Temperature	Ta(Industrial)		-40	25	+85	°C
Ambient Operating Temperature	Ta(Commercial)		0	25	+70	°C
Junction Temperature	TJ		-	-	+110	°C

11.3 Terminal Capacitance

TABLE 129 – TERMINAL CAPACITANCE

Parameter	Symbol	Conditions	Min.	Typ.	Max.	Unit
Input Capacitance	C _i	Measured at V _{in} =V _{out} =V _{ss} T _a =25°C	-	-	8	pF
Load Capacitance	C _o		-	-	20	pF
Load Capacitance for OCLK [3:0] signals	C _o		-	-	30	pF
Load Capacitance for microprocessor interface	C _o		-	-	100	pF

11.4 Thermal Characteristics

TABLE 130 – THERMAL CHARACTERISTICS

Parameter	Symbol	Conditions	Value
Typical Power Dissipation total	P _T	T _a =25°C	4.0W
Typical Power Dissipation from 1.8V	P _{VDD18}	T _a =25°C	2.1W
Typical Power Dissipation from 3.3V	P _{VDD33}	T _a =25°C	1.9W
Thermal Resistance (Junction to case)	Θ _{JC}		4.5 °C/W
Thermal Resistance (Junction to board)	Θ _{JB}		4.1 °C/W
Thermal Resistance (Ambient)	Θ _{JA}	Air flow 0.0m/s	15.4 °C/W
		Air flow 1.0m/s	11.7 °C/W
		Air flow 2.0m/s	10.2 °C/W

11.5 DC Electrical characteristics

TABLE 131 – DC ELECTRICAL CHARACTERISTICS

Parameter	Description	Min.	Typ.	Max.	Unit	Test Conditions
CMOS I/O						
V _{IL}	Input Low Voltage	-0.3	—	0.8	V	
V _{IH}	Input High Voltage	2.0	—	V _{D33} +0.3	V	
V _{OL}	Output Low Voltage	V _{SS}	—	0.4	V	V _{D33} =min, I _{OL} = max_load (Note 1)
V _{OH}	Output High Voltage	2.4	—	V _{D33}	V	V _{D33} =min, I _{OH} = max_load (Note 1)
V _{RESETBH}	RESETB Reset Input High Voltage	1.47	—	—	V	
V _{RESETBL}	RESETB Reset Input Low Voltage	—	—	0.95	V	
V _{RESETBHYST}	RESETB Reset Input Hysteresis Voltage	0.53	—	—	V	
I _{ILPU}	Input Low Current (with pullups)	-100	-50	-4	μA	V _{IL} =V _{SS}
I _{IHPU}	Input High Current (with pullups)	-10	0	+10	μA	V _{IL} =V _{D33}
I _{IL}	Input Low Current (without pullups)	-10	0	+10	μA	V _{IL} =V _{SS}
I _{IH}	Input High Current (without pullups)	-10	0	+10	μA	V _{IH} =V _{D33}
I _{OZ}	Offstate output current	-10	0	+10	μA	V _{D33} =MAX
LVTTL I/O						
V _{IL}	Input Low Voltage	-0.3	—	0.8	V	
V _{IH}	Input High Voltage	2.0	—	V _{D33} +0.3	V	
V _{OL}	Output Low Voltage	V _{SS}	—	0.4	V	V _{D33} =MIN, I _{OL} = 8mA
V _{OH}	Output High Voltage	2.4	—	V _{D33}	V	V _{D33} =MIN, I _{OH} = -8mA
I _L	Input Current	-5	0	+5	μA	V _{D33} =MAX
I _{OZ}	Offstate output current	-10	0	+10	μA	V _{D33} =MAX
SPI-4 LVDS I/O						
Input Characteristics						
V _{IN}	Input Voltage Range, V _P or V _N	0	—	2400	mV	V _{GPG} < 925 mV
V _{IDTH}	Differential Voltage Required to Toggle Input	100	—	—	mV	V _{GPG} < 925 mV
V _{HYST}	Input Differential Hysteresis, V _{IDTHH} - V _{IDTHL}	25	—	—	mV	
R _{IN}	Input Differential Impedance	90	100	110	Ohms	P to N input
Output Characteristics						
V _{OL}	Output Low Voltage, V _P or V _N	925	—	—	mV	R _{DIFF_TERM} = 100
V _{OH}	Output High Voltage, V _P or V _N	—	—	1475	mV	R _{DIFF_TERM} = 100
V _{OS}	Output Offset Voltage	1125	—	1375	mV	R _{DIFF_TERM} = 100
delta V _{OS}	Change in V _{OS} between "0" and "1"	—	—	25	mV	R _{DIFF_TERM} = 100
V _{OD}	Output Differential Voltage	250	—	450	mV	R _{DIFF_TERM} = 100
delta V _{OD}	Change in V _{OD} between "0" and "1"	50 (DC)	—	150 (AC)	mV	R _{DIFF_TERM} = 100
R _o	Output Single-ended Impedance	40	100	140	Ohms	
delta R _o	R _o mismatch between P and N	—	—	10	%	
I _{SP} , I _{SN}	Output Short Circuit Current	—	—	40	mA	P or N output shorted to V _{SS}
I _{SPN}	Output Short Circuit Current	—	—	12	mA	P and N outputs shorted together
I _{XP} , I _{XN}	Power-off output leakage	—	—	10	μA	V _{D33} = V _{SS}

NOTE:

1. Maximum load = 8 mA for microprocessor data bus DBUS[7:0]; maximum load= 4 mA for all other CMOS outputs.

11.6 AC characteristics

11.6.1 SPI-3 I/O timing

Refer to [SPI-3 in Glossary] for logical timing diagrams of the SPI-3 and SPI-4 interfaces. Note that underclocking and overclocking for the SPI-4 and SPI-3 interfaces is supported.

SPI-3 Input / Output

SPI-3 input and output timing is shown in the following paragraph.

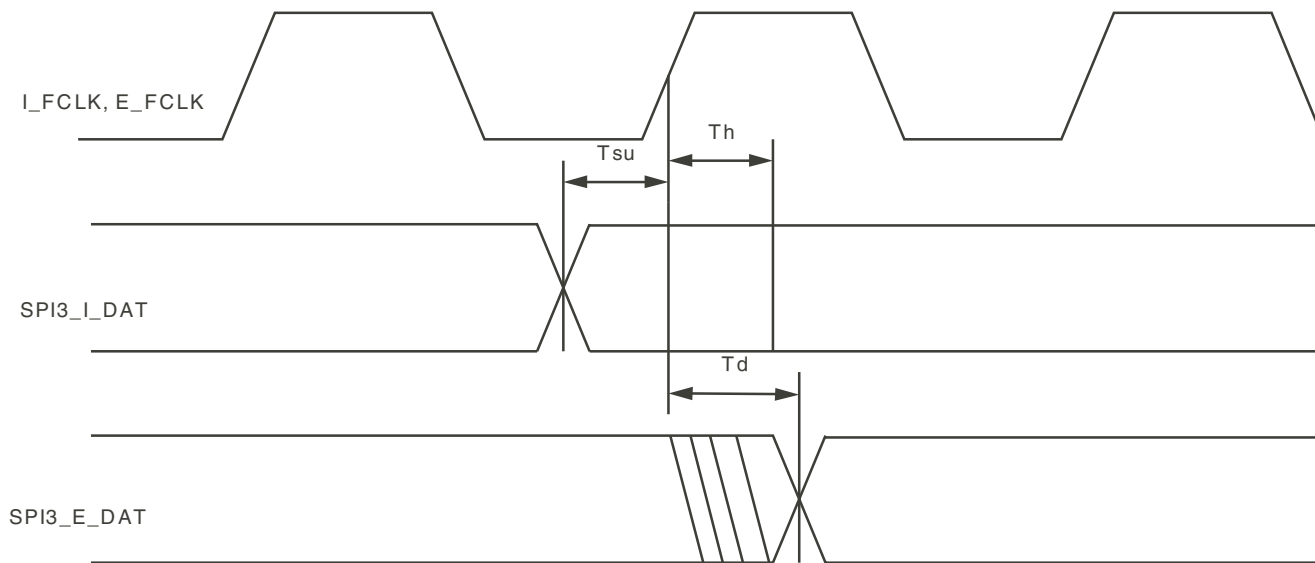

6371 drw05

Figure 35. SPI-3 I/O timing diagram

TABLE 132 – SPI-3 AC INPUT / OUTPUT TIMING SPECIFICATIONS

I_FCLK, E_FCLK	Unit	Min.	Typ.	Max.	Description
Duty cycle	%	30	—	70	Input SPI-3 clock duty cycle
Frequency	MHz	MCLK/4	—	133	I_FCLK, E_FCLK
TR, TF	ns	—	—	2	Rise fall time (20%, 80%)
All outputs					
TD	ns	2.33	—	5.65	Output delay after E_FCLK
TR, TF	ns	—	—	2	Rise fall time (20%, 80%)
All inputs					
TSU	ns	1	—	—	Input setup before I_FCLK
TH	ns	0.65	—	—	Input hold after I_FCLK

11.6.2 SPI-4 LVDS Input / Output

SPI-4 input and output timing is shown in the following paragraph. Double Data Rate protocol is used for data and status transfer. The SPI-4 LVDS signals use a dynamic data alignment at the ingress.

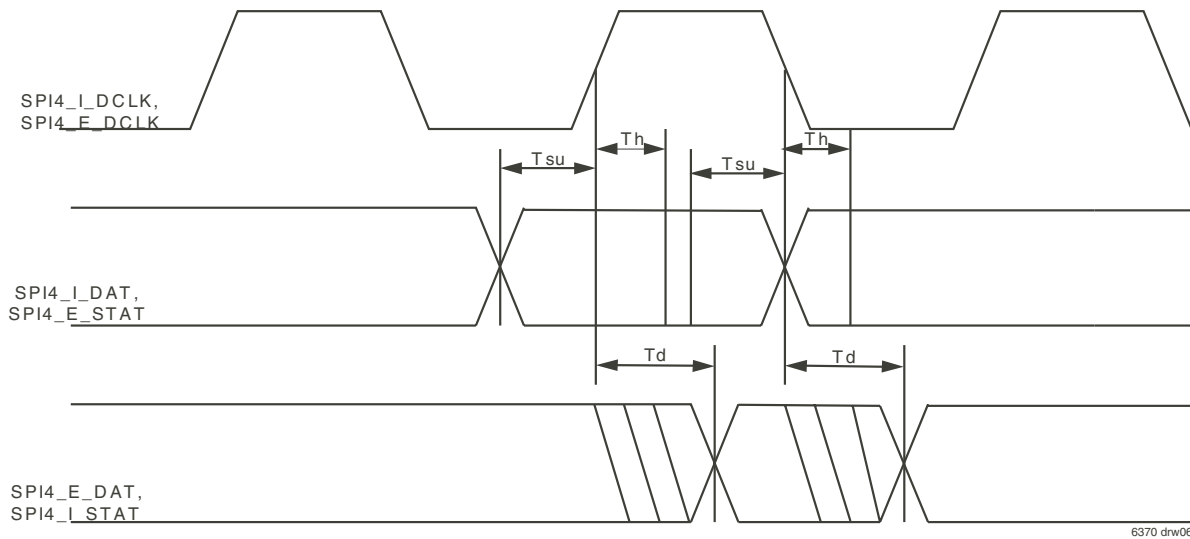

Figure 36. SPI-4 I/O timing diagram

TABLE 133 – SPI-4.2 LVDS AC INPUT / OUTPUT TIMING SPECIFICATIONS

Inputs	Unit	Min.	Typ.	Max.	Description
Duty cycle	%	45	50	55	I_DCLK ingress clock duty cycle
Frequency (DDR)	MHz	80	—	200	Ingress clock frequency, I_LOW=1
Frequency (DDR)	MHz	200	311	400	Ingress clock frequency, I_LOW=0
TR, TF	ps	300	—	500	Input rise or fall time (20%, 80%)
Deskew	UI	—	—	+/- 1	Bit line deskew
Outputs					
Duty cycle	%	45	50	55	E_DCLK Egress clock duty cycle
Frequency (DDR)	MHz	80	—	200	Egress clock frequency, E_LOW=1
Frequency (DDR)	MHz	200	311	400	Egress clock frequency, E_LOW=0
TR, TF	ps	300	—	500	Output rise or fall time (20%, 80%)
Tskew	ps	—	—	50	Output differential skew, P to N
SYNTH Jitter	UI	—	—	0.1	PLL jitter as a fraction of the clock cycle
TD	ns	—	—	—	Adjustable

11.6.3 SPI-4 LVTTTL Status AC characteristics

TABLE 134 – SPI-4 LVTTTL STATUS AC CHARACTERISTICS

Parameter	Symbol	Conditions	Min	Typ	Max	Unit
SPI-4 LVTTTL Status⁽¹⁾						
STAT_T[1:0] to SCLK_T setup time	T _{SU}		2			ns
SCLK_T to STAT_T [1:0] hold time	T _H		0.5			ns
SCLK_T to STAT_T [1:0] delay	T _D			1	1.2	ns

NOTE:

1. For the SPI-4 LVTTTL valid, hold & setup the edge is configurable. The SPI-4 ingress LVTTTL status clock active edge is configured by I_CLK_EDGE field in Table 89-SPI-4 Ingress Configuration Register on page 69. The SPI-4 egress LVTTTL status clock active edge is configured by E_CLK_EDGE field in Table 104-SPI-4 Egress Configuration Register on page 73.

11.6.4 REF_CLK clock input

TABLE 135 – REF_CLK CLOCK INPUT

REF_CLK	Unit	Min.	Typ.	Max.	
Duty cycle	%	30	50	70	REF_CLK clock input duty cycle
FREF_CLK	MHz	12.5	19.44	25	Main reference clock input
TR, TF	ns	—	—	5	Rise fall time (20%, 80%)

11.6.5 MCLK internal clock and OCLK[3:0] clock outputs

TABLE 136 – OCLK[3:0] CLOCK OUTPUTS AND MCLK INTERNAL CLOCK

OCLK[3:0]	Unit	Min.	Typ.	Max.	Description
Duty cycle	%	45	50	55	OCLK[3:0] outputs, clock duty cycle
Frequency	MHz	40	104	133	OCLK[3:0], programmable
Output skew between OCLKs					One pll_ock cycle of deliberate skew between each OCLK[3:0]
TR, TF	ns	1		2	OCLK[3:0] rise, fall time (20%,80%)
MCLK					
Frequency	MHz	80	—	100	Programmable

11.6.6 Microprocessor interface

TABLE 137 – MICROPROCESSOR INTERFACE

All outputs	Unit	Min.	Typ.	Max.	Description
TR, Tf	ns			10	Rise, fall time (20%, 80%)
All inputs					
TR, Tf	ns			10	Rise, fall time (20%,80%)

11.6.6.1 Microprocessor parallel port AC timing specifications

Be sure to connect SPI_EN to a logic low when using the parallel μ P interface mode.

Read cycle specification Motorola non-multiplexed (MPM=0)

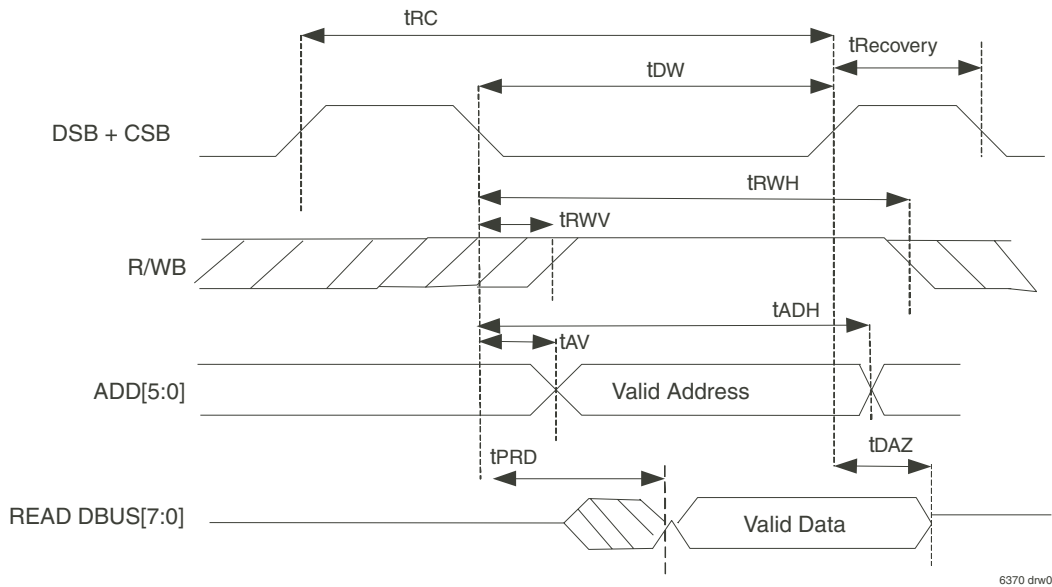

6370 drw07

Figure 37. Microprocessor parallel port Motorola read timing diagram

TABLE 138 – MICROPROCESSOR PARALLEL PORT MOTOROLA READ TIMING

Symbol	Parameter	MIN	MAX	Unit
T	Internal main clock period (MCLK)	80	100	MHz
tRC	Read cycle time	$5.5T+25$		ns
tDW	Valid DSB width	$5.5T+20$		ns
tRWV	Delay from DSB to valid read signal		$T/2-4$	ns
tRWH	R/WB to DSB hold time	$2T+10$		ns
tAV	Delay from DSB to Valid Address		$T/2-4$	ns
tADH	Address to DSB hold time	$2T+10$		ns
tRPD	DSB to valid read data propagation delay		$5.5T+20$	ns
tDAZ	Delay from read data active to high Z		12	ns
tRecovery	Recovery time from read cycle	5		ns

Write cycle specification Motorola non-multiplexed (MPM=0)

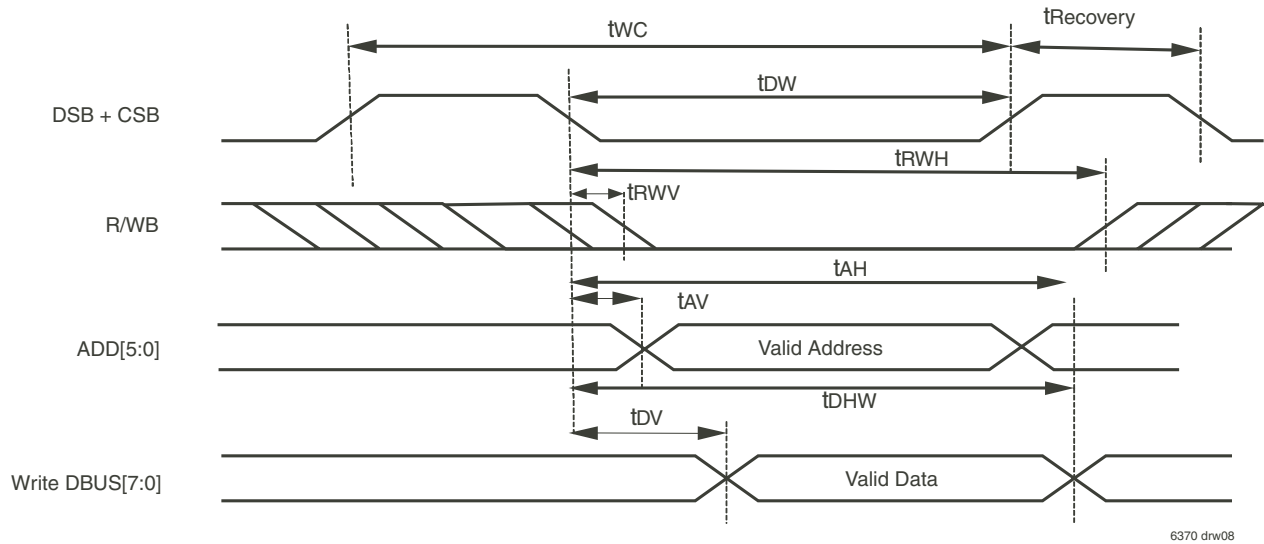
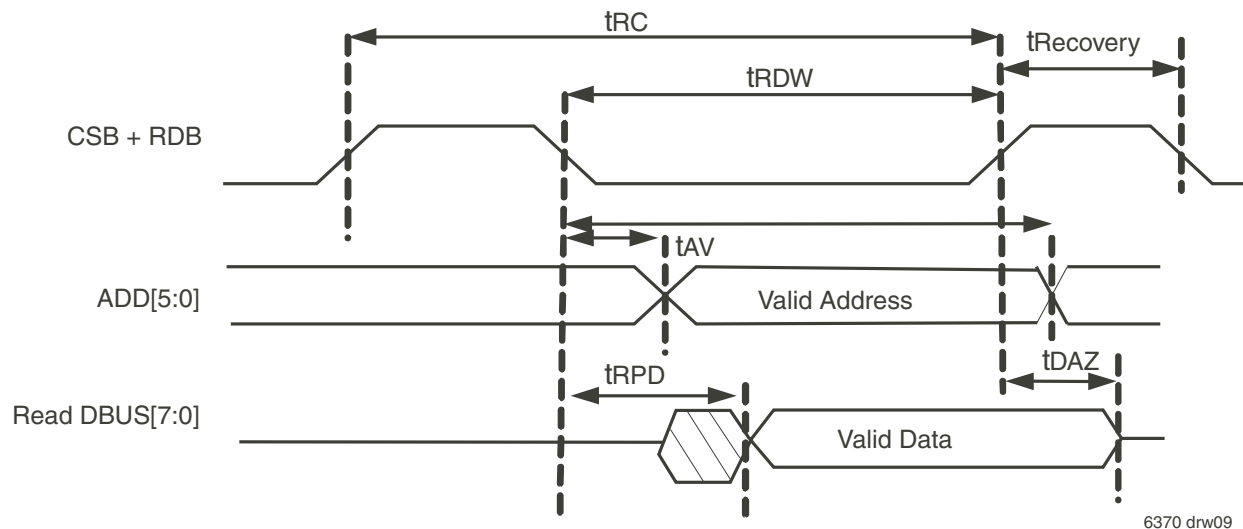

Figure 38. Microprocessor parallel port Motorola write timing diagram

TABLE 139 – MICROPROCESSOR PARALLEL PORT MOTOROLA WRITE TIMING

Symbol	Parameter	MIN	MAX	Unit
T	Internal main clock period (MCLK)	80	100	MHz
t_{WC}	Write cycle time	$2.5T+17$		ns
t_{DW}	Valid DSB width	$2.5T+12$		ns
t_{RWW}	Delay from DSB to valid write signal		$T/2-4$	ns
t_{RWH}	R/WB to DSB hold time	$2.5T+12$		ns
t_{AV}	Delay from DSB to Valid Address		$T/2-4$	ns
t_{AH}	Address to DSB hold time	$2.5T+12$		ns
t_{DV}	Delay from DSB to valid write data		$T/2-4$	ns
t_{DHW}	Write data to DSB hold time	$2.5T+12$		ns
$t_{Recovery}$	Recovery time from write cycle	5		ns

Read cycle specification Intel non-multiplexed bus (MPM=1)



NOTE:
1. WRB should be tied to High.

Figure 39. Microprocessor parallel port Intel mode read timing diagram

TABLE 140 – MICROPROCESSOR PARALLEL PORT INTEL MODE READ TIMING

Symbol	Parameter	MIN	MAX	Unit
T	Internal main clock period (MCLK)	80	100	MHz
t_{RC}	Read cycle time	$5.5T+25$		ns
t_{RDW}	Valid RDB width	$5.5T+20$		ns
t_{AV}	Delay from RDB to Valid Address		$T/2-4$	ns
t_{AH}	Address to RDB hold time	$2.5T+12$		ns
t_{RPD}	RDB to valid read data propagation delay		$5.5T-20$	ns
t_{DAZ}	Delay from read data active to High-Z		12	ns
$t_{Recovery}$	Recovery time from read cycle	5		ns

Write cycle specification Intel non-multiplexed bus (MPM=1)

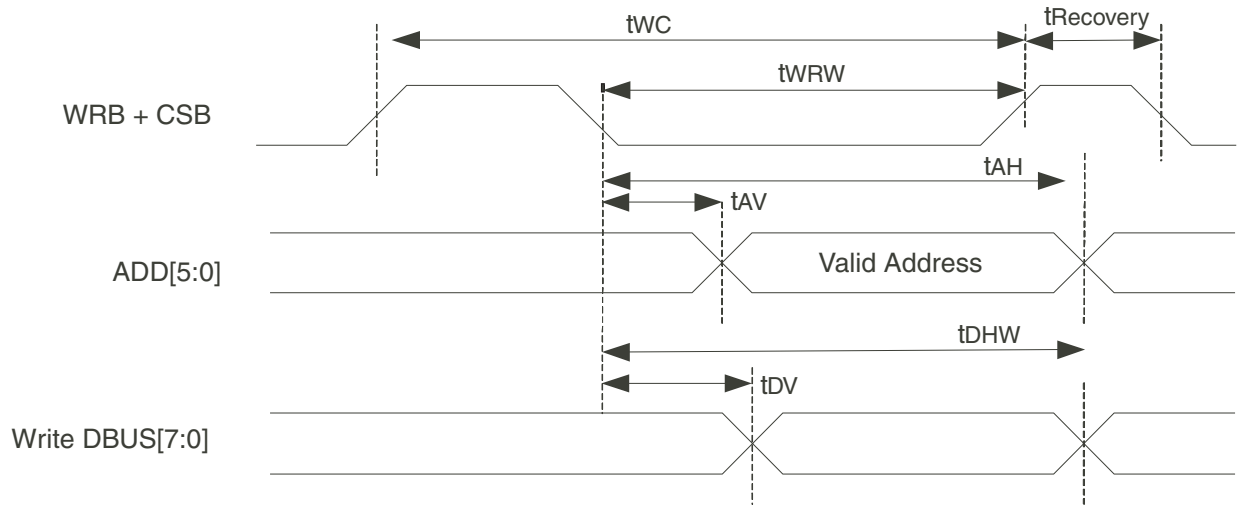

6370 dnr10

NOTE:

1. RDB should be tied to a logic one.

Figure 40. Microprocessor parallel port Intel mode write timing diagram

TABLE 141 – MICROPROCESSOR PARALLEL PORT INTEL MODE WRITE TIMING

Symbol	Parameter	MIN	MAX	Unit
T	Internal main clock period (MCLK)	80	100	MHz
tWC	Write cycle time	2.5T+19		ns
tWRW	Valid WRB width	2.5T+14		ns
tAV	Delay from WRB to Valid Address		T/2-2	ns
tAH	Address to WRB hold time	2.5T+12		ns
tDV	Delay from WRB to valid write data		T/2-2	ns
tDHW	Write data to WRB hold time	2.5T+12		ns
tRecovery	Recovery time from read cycle	5		ns

11.6.6.2 Serial microprocessor interface (serial peripheral interface mode)

Timing Characteristics

The maximum SPI Data transfer clock frequency is 2 MHz. The detail information of the timing characteristics is shown in below and timing diagram is shown in Figure 41, *Microprocessor serial peripheral interface timing diagram*.

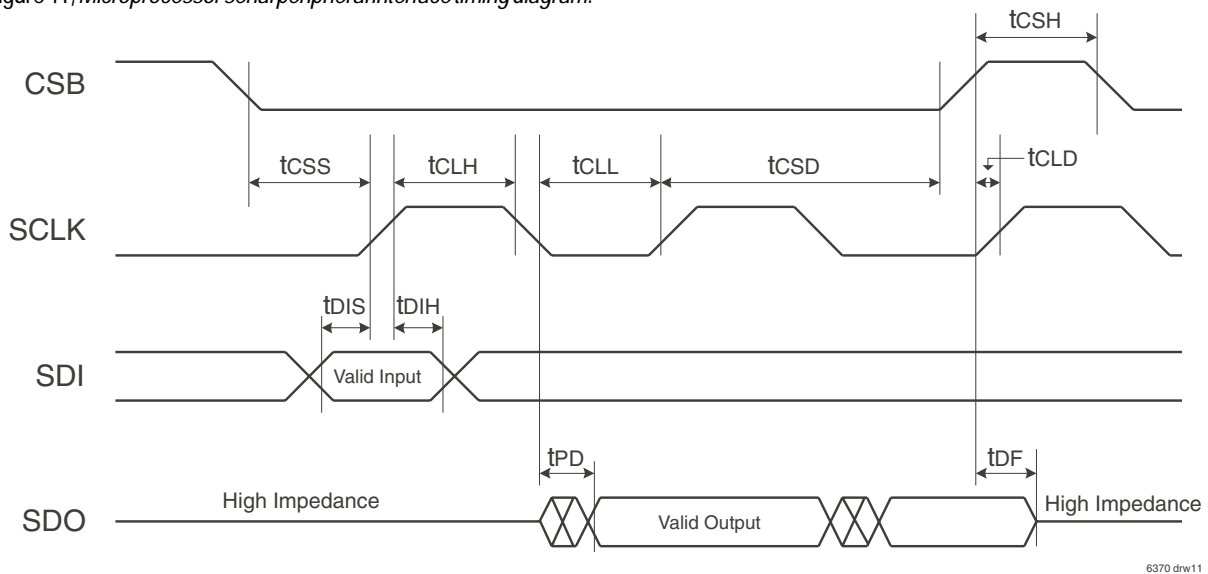

Figure 41. Microprocessor serial peripheral interface timing diagram

TABLE 142 – MICROPROCESSOR SERIAL PERIPHERAL INTERFACE TIMING

Symbol	Description	Min.	Max.	Unit
f _{OP}	SCLK Frequency		2.0	MHz
t _{CSH}	Minimum CSB High Time	100		ns
t _{CSS}	CSB Setup Time	50		ns
t _{CSD}	CSB Hold Time	100		ns
t _{CLD}	SCLK Clock Disable Time	50		ns
t _{CLH}	SCLK Clock High Time	205		ns
t _{CLL}	SCLK Clock Low Time	205		ns
t _{DIS}	SDI Data Setup Time	50		ns
t _{DIH}	SDI Data Hold Time	150		ns
t _{PD}	SDO Output Delay		150	ns
t _{DF}	SDO Output Disable Time		50	ns

12. MECHANICAL CHARACTERISTICS

12.1 Device overview

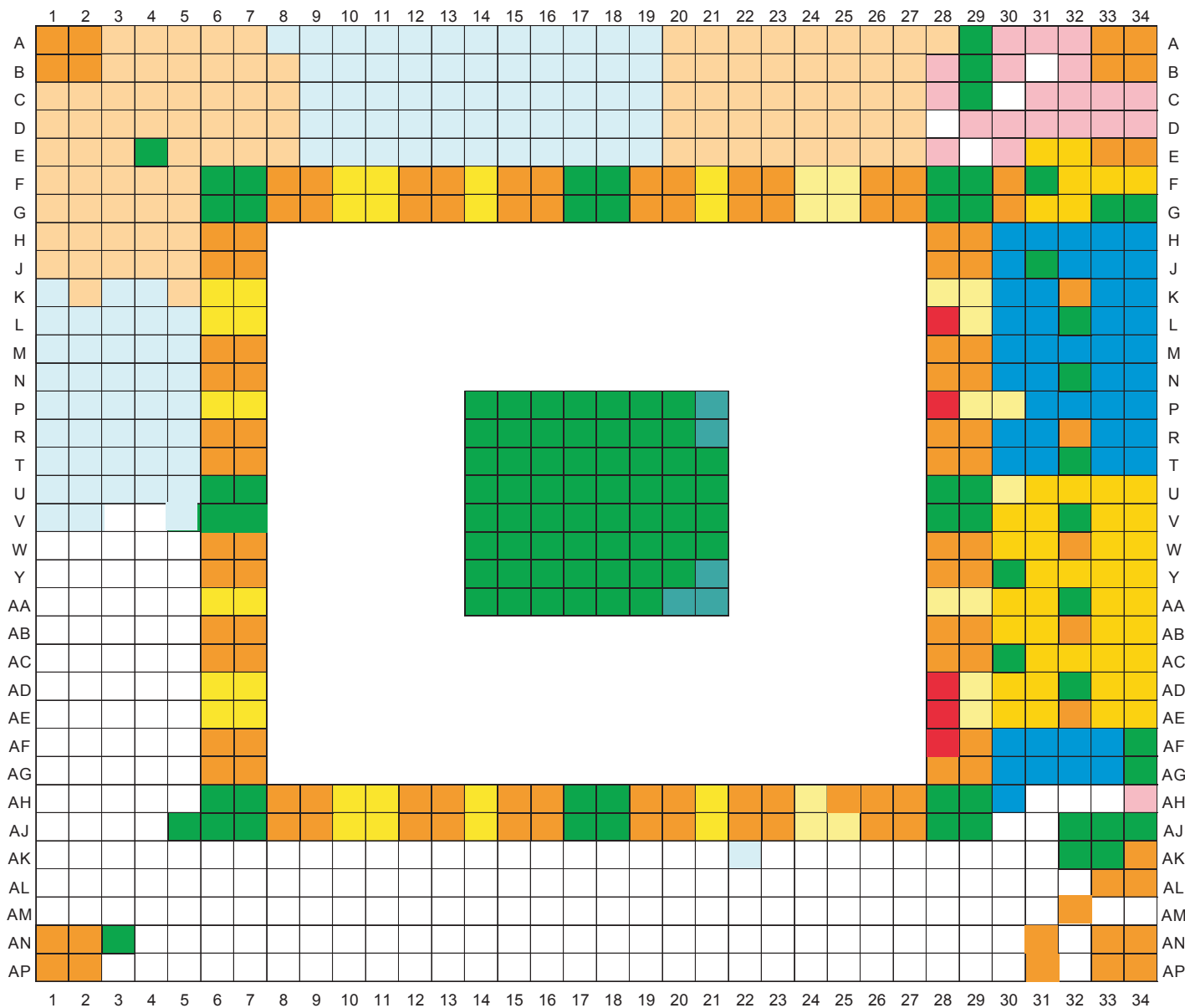

6370 drw04

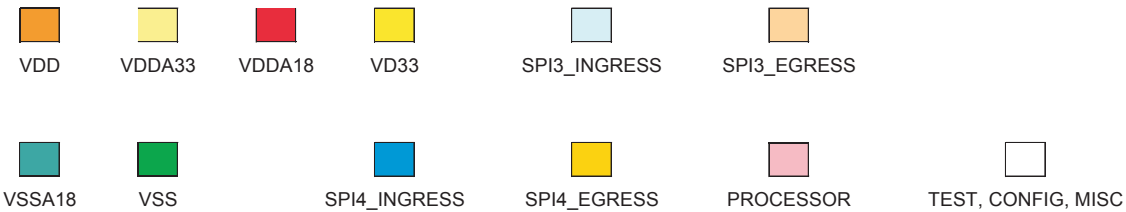

PBGA (BH820-1, order code: BH)
TOP VIEW

12.2 Pin name/ball location table

SIGNAL PIN NAME	BALL	SIGNAL PIN NAME	BALL	SIGNAL PIN NAME	BALL	SIGNAL PIN NAME	BALL
SPI3B_E_DAT[21]	A4	SPI3B_I_DAT[26]	N5	RESERVED	AC5	RESERVED	AM6
SPI3B_E_DAT[20]	E5	SPI3B_I_DAT[25]	N3	RESERVED	AC4	RESERVED	AL6
SPI3B_E_DAT[19]	B4	SPI3B_I_DAT[24]	N2	RESERVED	AD1	RESERVED	AP6
SPI3B_E_DAT[18]	D4	SPI3B_I_DAT[23]	N1	RESERVED	AD2	RESERVED	AN6
SPI3B_E_DAT[17]	A3	SPI3B_I_DAT[22]	R5	RESERVED	AD5	RESERVED	AL7
SPI3B_E_DAT[16]	C4	SPI3B_I_DAT[21]	P5	RESERVED	AD4	RESERVED	AK7
SPI3B_E_DAT[15]	B3	SPI3B_I_DAT[20]	P4	RESERVED	AD3	RESERVED	AN7
SPI3B_E_DAT[14]	C2	SPI3B_I_DAT[19]	P2	RESERVED	AE1	RESERVED	AM7
SPI3B_E_DAT[13]	C1	SPI3B_I_DAT[18]	P1	RESERVED	AE3	RESERVED	AK8
SPI3B_E_DAT[12]	C3	SPI3B_I_DAT[17]	P3	RESERVED	AE2	RESERVED	AP7
SPI3B_E_DAT[11]	D3	SPI3B_I_DAT[16]	R4	RESERVED	AE4	RESERVED	AM8
SPI3B_E_DAT[10]	D1	SPI3B_I_DAT[15]	R3	RESERVED	AF3	RESERVED	AL8
SPI3B_E_DAT[9]	F5	SPI3B_I_DAT[14]	T5	RESERVED	AE5	RESERVED	AK9
SPI3B_E_DAT[8]	D2	SPI3B_I_DAT[13]	R2	RESERVED	AF1	RESERVED	AN8
SPI3B_E_DAT[7]	E3	SPI3B_I_DAT[12]	R1	RESERVED	AF2	RESERVED	AP8
SPI3B_E_DAT[6]	E1	SPI3B_I_DAT[11]	T4	RESERVED	AF5	RESERVED	AL9
SPI3B_E_DAT[5]	F4	SPI3B_I_DAT[10]	U5	RESERVED	AF4	RESERVED	AK10
SPI3B_E_DAT[4]	E2	SPI3B_I_DAT[9]	T3	RESERVED	AG2	RESERVED	AM9
SPI3B_E_DAT[3]	F3	SPI3B_I_DAT[8]	T2	RESERVED	AG1	RESERVED	AN9
SPI3B_E_DAT[2]	F2	SPI3B_I_DAT[7]	T1	RESERVED	AG4	RESERVED	AP9
SPI3B_E_DAT[1]	G4	SPI3B_I_DAT[6]	U3	RESERVED	AG3	RESERVED	AL10
SPI3B_E_DAT[0]	F1	SPI3B_I_DAT[5]	U4	RESERVED	AH1	RESERVED	AM10
SPI3B_E_FCLK	G5	SPI3B_I_DAT[4]	U2	RESERVED	AH2	RESERVED	AN10
SPI3B_PTPA	G3	SPI3B_I_DAT[3]	U1	RESERVED	AH3	RESERVED	AP10
SPI3B_TADR[7]	H5	SPI3B_I_DAT[2]	V5	RESERVED	AG5	RESERVED	AK12
SPI3B_TADR[6]	G2	SPI3B_I_DAT[1]	V1	RESERVED	AH4	RESERVED	AK11
SPI3B_TADR[5]	G1	SPI3B_I_DAT[0]	V2	RESERVED	AJ1	RESERVED	AL11
SPI3B_TADR[4]	H4	RESERVED	V4	RESERVED	AJ4	RESERVED	AN11
SPI3B_TADR[3]	H2	RESERVED	W3	RESERVED	AJ2	RESERVED	AP11
SPI3B_TADR[2]	H3	RESERVED	W1	RESERVED	AJ3	RESERVED	AM11
SPI3B_TADR[1]	H1	RESERVED	V3	RESERVED	AK1	RESERVED	AL12
SPI3B_TADR[0]	J5	RESERVED	W2	RESERVED	AK2	RESERVED	AM12
SPI3B_STPA	J4	RESERVED	W5	RESERVED	AH5	RESERVED	AK13
SPI3B_DTPA[3]	J3	RESERVED	W4	RESERVED	AK4	RESERVED	AN12
SPI3B_DTPA[2]	J2	RESERVED	Y1	RESERVED	AL1	RESERVED	AP12
SPI3B_DTPA[1]	J1	RESERVED	Y2	RESERVED	AL2	RESERVED	AL13
SPI3B_DTPA[0]	K5	RESERVED	Y5	RESERVED	AK3	RESERVED	AM13
SPI3B_I_ENB	K4	RESERVED	Y3	RESERVED	AM1	RESERVED	AN13
SPI3B_I_SX	K3	RESERVED	Y4	RESERVED	AM2	RESERVED	AP13
SPI3B_RVAL	K2	RESERVED	AA1	RESERVED	AM3	RESERVED	AN14
SPI3B_I_ERR	K1	RESERVED	AA5	RESERVED	AL3	RESERVED	AK14
SPI3B_I_FCLK	L5	RESERVED	AA2	RESERVED	AP3	RESERVED	AL14
SPI3B_I_SOP	L4	RESERVED	AA3	RESERVED	AL4	RESERVED	AM14
SPI3B_I_PRTY	L3	RESERVED	AA4	RESERVED	AM4	RESERVED	AP14
SPI3B_I_MOD[1]	M5	RESERVED	AB4	RESERVED	AN4	RESERVED	AM15
SPI3B_I_MOD[0]	L2	RESERVED	AB1	RESERVED	AP4	RESERVED	AL15
SPI3B_I_EOP	L1	RESERVED	AB2	RESERVED	AK5	RESERVED	AN15
SPI3B_I_DAT[31]	M4	RESERVED	AC2	RESERVED	AL5	RESERVED	AP15
SPI3B_I_DAT[30]	M3	RESERVED	AB5	RESERVED	AN5	RESERVED	AK15
SPI3B_I_DAT[29]	M2	RESERVED	AB3	RESERVED	AM5	RESERVED	AL16
SPI3B_I_DAT[28]	M1	RESERVED	AC1	RESERVED	AK6	RESERVED	AK16
SPI3B_I_DAT[27]	N4	RESERVED	AC3	RESERVED	AP5	RESERVED	AM16

12.2. Pin name/ball location table (continued)

SIGNAL PIN NAME	BALL	SIGNAL PIN NAME	BALL	SIGNAL PIN NAME	BALL	SIGNAL PIN NAME	BALL
RESERVED	AK17	RESERVED	AL26	SPI4_E_DAT_N[12]	AC31	SPI4_I_DAT_N[4]	K31
RESERVED	AN16	RESERVED]	AM27	SPI4_E_DAT_P[11]	AC34	SPI4_I_DAT_P[3]	K30
RESERVED	AP16	RESERVED	AN27	SPI4_E_DAT_N[11]	AC33	SPI4_I_DAT_N[3]	J30
RESERVED	AL17	RESERVED	AK27	SPI4_E_DAT_P[10]	AB31	SPI4_I_DAT_P[2]	J32
RESERVED	AK18	RESERVED	AL27	SPI4_E_DAT_N[10]	AB30	SPI4_I_DAT_N[2]	J33
RESERVED	AM17	RESERVED	AN28	SPI4_E_DAT_P[9]	AB34	SPI4_I_DAT_P[1]	J34
RESERVED	AN17	RESERVED	AP28	SPI4_E_DAT_N[9]	AB33	SPI4_I_DAT_N[1]	H34
RESERVED	AP17	RESERVED	AL28	SPI4_E_DAT_P[8]	AA31	SPI4_I_DAT_P[0]	H32
RESERVED	AK20	RESERVED	AM28	SPI4_E_DAT_N[8]	AA30	SPI4_I_DAT_N[0]	H33
RESERVED	AL18	RESERVED	AP29	SPI4_E_DAT_P[7]	AA34	SPI4_I_CTRL_P	H30
RESERVED	AM18	RESERVED	AK28	SPI4_E_DAT_N[7]	AA33	SPI4_I_CTRL_N	H31
RESERVED	AP18	RESERVED	AM29	SPI4_E_DAT_P[6]	Y32	SPI4_E_SCLK_P	G31
RESERVED	AK19	RESERVED	AN29	SPI4_E_DAT_N[6]	Y31	SPI4_E_SCLK_N	G32
RESERVED	AP19	REF_CLK	AP30	SPI4_E_DAT_P[5]	Y34	SPI4_E_STAT_P[1]	F33
RESERVED	AN18	TCK	AL29	SPI4_E_DAT_N[5]	Y33	SPI4_E_STAT_N[1]	F34
RESERVED	AN19	LVDS_STA	AN30	SPI4_E_DAT_P[4]	W31	SPI4_E_STAT_P[0]	F32
RESERVED	AK22	TDI	AM30	SPI4_E_DAT_N[4]	W30	SPI4_E_STAT_N[0]	E32
RESERVED	AL19	TDO	AP32	SPI4_E_DAT_P[3]	W34	SPI4_E_STAT_T[1]	L30
RESERVED	AP20	TMS	AN32	SPI4_E_DAT_N[3]	W33	SPI4_E_STAT_T[0]	M30
RESERVED	AM20	GPIO[4]	AM31	SPI4_E_DAT_P[2]	V31	SPI4_E_SCLK_T	E31
RESERVED	AM19	GPIO[3]	AM33	SPI4_E_DAT_N[2]	V30	SPI_EN	E29
RESERVED	AL20	GPIO[2]	AM34	SPI4_E_DAT_P[1]	V34	DBUS[7]	E30
RESERVED	AN20	CLK_SEL[3]	AL31	SPI4_E_DAT_N[1]	V33	ADD[5]	D33
RESERVED	AP21	GPIO[1]	AL30	SPI4_E_DAT_P[0]	U32	DBUS[6]	D34
RESERVED	AK21	CLK_SEL[2]	AK29	SPI4_E_DAT_N[0]	U31	ADD[4]	D31
RESERVED	AN21	GPIO[0]	AL32	SPI4_E_CTRL_P	U34	DBUS[5]	D32
RESERVED	AM21	CLK_SEL[1]	AK30	SPI4_E_CTRL_N	U33	ADD[3]	C34
RESERVED	AL21	OCLK[3]	AK31	SPI4_I_DCLK_P	T34	DBUS[4]	D30
RESERVED	AP22	CLK_SEL[0]	AH31	SPI4_I_DCLK_N	T33	WRB	C33
RESERVED	AN22	OCLK[2]	AJ30	SPI4_I_DAT_P[15]	T31	DBUS[3]	C32
RESERVED	AM22	TIMEBASE	AH34	SPI4_I_DAT_N[15]	T30	CSB	B32
RESERVED	AL22	OCLK[1]	AH32	SPI4_I_DAT_P[14]	R34	DBUS[2]	C31
RESERVED	AK23	OCLK[0]	AH33	SPI4_I_DAT_N[14]	R33	DBUS[1]	A32
RESERVED	AP23	SPI4_I_STAT_T[1]	AH30	SPI4_I_DAT_P[13]	R31	RESETB	C30
RESERVED	AN23	SPI4_I_STAT_T[0]	AG32	SPI4_I_DAT_N[13]	R30	INTB	A31
RESERVED	AL23	SPI4_I_SCLK_T	AG33	SPI4_I_DAT_P[12]	P34	DBUS[0]	A30
RESERVED	AM23	BIAS	AJ31	SPI4_I_DAT_N[12]	P33	ADD[2]	B30
RESERVED	AP24	SPI4_I_STAT_P[1]	AG31	SPI4_I_DAT_P[11]	P32	RDB	E28
RESERVED	AM24	SPI4_I_STAT_P[0]	AF31	SPI4_I_DAT_N[11]	P31	ADD[1]	D29
RESERVED	AN24	SPI4_I_STAT_N[1]	AG30	SPI4_I_DAT_P[10]	N34	TRSTB	D28
RESERVED	AK24	SPI4_I_STAT_N[0]	AF30	SPI4_I_DAT_N[10]	N33	ADD[0]	B28
RESERVED	AL24	SPI4_I_SCLK_P	AF33	SPI4_I_DAT_P[9]	N31	MPM	C28
RESERVED	AP25	SPI4_I_SCLK_N	AF32	SPI4_I_DAT_N[9]	N30	SPI3A_E_SOP	A28
RESERVED	AN25	SPI4_E_DCLK_P	AE34	SPI4_I_DAT_P[8]	M34	SPI3A_E_ERR	E27
RESERVED	AK25	SPI4_E_DCLK_N	AE33	SPI4_I_DAT_N[8]	M33	SPI3A_E_MOD[1]	C27
RESERVED	AL25	SPI4_E_DAT_P[15]	AE30	SPI4_I_DAT_P[7]	M32	SPI3A_E_MOD[0]	D27
RESERVED	AM25	SPI4_E_DAT_N[15]	AE31	SPI4_I_DAT_N[7]	M31	SPI3A_E_EOP	B27
RESERVED	AP26	SPI4_E_DAT_P[14]	AD31	SPI4_I_DAT_P[6]	L34	SPI3A_E_ENB	A27
RESERVED	AN26	SPI4_E_DAT_N[14]	AD30	SPI4_I_DAT_N[6]	L33	SPI3A_E_SX	D26
RESERVED	AP27	SPI4_E_DAT_P[13]	AD34	SPI4_I_DAT_P[5]	K33	SPI3A_E_PRTY	E26
RESERVED	AM26	SPI4_E_DAT_N[13]	AD33	SPI4_I_DAT_N[5]	K34	SPI3A_E_DAT[31]	C26
RESERVED	AK26	SPI4_E_DAT_P[12]	AC32	SPI4_I_DAT_P[4]	L31	SPI3A_E_DAT[30]	B26

12.2 Pin name/ball location table (continued)

SIGNAL PIN NAME	BALL	SIGNAL PIN NAME	BALL	SIGNAL PIN NAME	BALL	SIGNAL PIN NAME	BALL
SPI3A_E_DAT[29]	A26	SPI3A_E_DAT[2]	C20	SPI3A_I_EOP	D15	SPI3A_I_DAT[5]	A9
SPI3A_E_DAT[28]	E25	SPI3A_E_DAT[1]	B20	SPI3A_I_DAT[31]	E15	SPI3A_I_DAT[4]	B9
SPI3A_E_DAT[27]	D25	SPI3A_E_DAT[0]	D20	SPI3A_I_DAT[30]	A14	SPI3A_I_DAT[3]	D9
SPI3A_E_DAT[26]	C25	SPI3A_E_FCLK	A20	SPI3A_I_DAT[29]	E14	SPI3A_I_DAT[2]	E9
SPI3A_E_DAT[25]	A25	SPI3A_PTPA	C19	SPI3A_I_DAT[28]	B14	SPI3A_I_DAT[1]	C9
SPI3A_E_DAT[24]	B25	SPI3A_TADR[7]	B19	SPI3A_I_DAT[27]	C14	SPI3A_I_DAT[0]	A8
SPI3A_E_DAT[23]	C24	SPI3A_TADR[6]	D19	SPI3A_I_DAT[26]	D14	SPI3B_E_SOP	C8
SPI3A_E_DAT[22]	D24	SPI3A_TADR[5]	A19	SPI3A_I_DAT[25]	E13	SPI3B_E_ERR	D8
SPI3A_E_DAT[21]	D23	SPI3A_TADR[4]	A18	SPI3A_I_DAT[24]	A13	SPI3B_E_MOD[1]	B8
SPI3A_E_DAT[20]	E23	SPI3A_TADR[3]	B18	SPI3A_I_DAT[23]	B13	SPI3B_E_MOD[0]	E8
SPI3A_E_DAT[19]	B24	SPI3A_TADR[2]	E19	SPI3A_I_DAT[22]	C13	SPI3B_E_EOP	B7
SPI3A_E_DAT[18]	A24	SPI3A_TADR[1]	C18	SPI3A_I_DAT[21]	E12	SPI3B_E_ENB	C7
SPI3A_E_DAT[17]	C23	SPI3A_TADR[0]	D18	SPI3A_I_DAT[20]	D13	SPI3B_E_SX	A7
SPI3A_E_DAT[16]	E24	SPI3A_STPA	A17	SPI3A_I_DAT[19]	A12	SPI3B_E_PRTY	A6
SPI3A_E_DAT[15]	B23	SPI3A_DTPA[3]	E18	SPI3A_I_DAT[18]	B12	SPI3B_E_DAT[31]	D7
SPI3A_E_DAT[14]	A23	SPI3A_DTPA[2]	B17	SPI3A_I_DAT[17]	E11	SPI3B_E_DAT[30]	B6
SPI3A_E_DAT[13]	D22	SPI3A_DTPA[1]	C17	SPI3A_I_DAT[16]	D12	SPI3B_E_DAT[29]	E7
SPI3A_E_DAT[12]	E22	SPI3A_DTPA[0]	D17	SPI3A_I_DAT[15]	C12	SPI3B_E_DAT[28]	E6
SPI3A_E_DAT[11]	C22	SPI3A_I_ENB	E17	SPI3A_I_DAT[14]	A11	SPI3B_E_DAT[27]	C6
SPI3A_E_DAT[10]	B22	SPI3A_I_SX	A16	SPI3A_I_DAT[13]	C11	SPI3B_E_DAT[26]	A5
SPI3A_E_DAT[9]	A22	SPI3A_RVAL	B16	SPI3A_I_DAT[12]	D11	SPI3B_E_DAT[25]	D6
SPI3A_E_DAT[8]	E21	SPI3A_I_ERR	C16	SPI3A_I_DAT[11]	B11	SPI3B_E_DAT[24]	B5
SPI3A_E_DAT[7]	D21	SPI3A_I_FCLK	D16	SPI3A_I_DAT[10]	A10	SPI3B_E_DAT[23]	D5
SPI3A_E_DAT[6]	C21	SPI3A_I_SOP	B15	SPI3A_I_DAT[9]	B10	SPI3B_E_DAT[22]	C5
SPI3A_E_DAT[5]	B21	SPI3A_I_PRTY	A15	SPI3A_I_DAT[8]	C10		
SPI3A_E_DAT[4]	E20	SPI3A_I_MOD[1]	C15	SPI3A_I_DAT[7]	E10		
SPI3A_E_DAT[3]	A21	SPI3A_I_MOD[0]	E16	SPI3A_I_DAT[6]	D10		

POWER PIN NAME	BALL(S)
VDDA18_CLKGEN	AF28
VSSA18_CLKGEN	AA20
VDDA18_ISTX	AD28
VSSA18_ISTX	Y21
VDDA18_EDTX	AE28
VSSA18_EDTX	AA21
VDDA18_IDRX	P28
VSSA18_IDRX	R21
VDDA18_ESRX	L28
VSSA18_ESRX	P21
VSS (GND)	A29, B29, C29, E4, F6, F7, F17, F18, F28, F29, F31, G6, G7, G17, G18, G28, G29, G33, G34, J31, L32, N32, P14 - P20, R14- R20, T14 - T21, T32, U6, U7, U14 - U21, U28, U29, V6, V7, V14 - V21, V28, V29, V32, W14 - W21, Y14 - Y20, Y30, AA14 - AA19, AA32, AC30, AD32, AF34, AG34, AH6, AH7, AH17, AH18, AH28, AH29, AJ5 - AJ7, AJ17, AJ18, AJ28, AJ29, AJ32 - AJ34, AK32, AK33, AN3, AP31, AN31, B31, AM32
VDD18 (1.8 VOLTS)	A1, A2, A33, A34, B1, B2, B33, B34, E33, E34, F8, F9, F12, F13, F15, F16, F19, F20, F22, F23, F26, F27, F30, G8, G9, G12, G13, G15, G16, G19, G20, G22, G23, G26, G27, G30, H6, H7, H28, H29, J6, J7, J28, J29, K32, M6, M7, M28, M29, N6, N7, N28, N29, R6, R7, R28, R29, R32, T6, T7, T28, T29, W6, W7, W28, W29, W32, Y6, Y7, Y28, Y29, AB6, AB7, AB28, AB29, AB32, AC6, AC7, AC28, AC29, AE32, AF6, AF7, AH25, AF29, AG6, AG7, AG28, AG29, AH8, AH9, AH12, AH13, AH15, AH16, AH19, AH20, AH22, AH23, AH26, AH27, AJ8, AJ9, AJ12, AJ13, AJ15, AJ16, AJ19, AJ20, AJ22, AJ23, AJ26, AJ27, AK34, AL33, AL34, AN1, AN2, AN33, AN34, AP1, AP2, AP33, AP34
VD33 (3.3 VOLTS)	F10, F11, F14, F21, G10, G11, G14, G21, K6, K7, L6, L7, P6, P7, AA6, AA7, AD6, AD7, AE6, AE7, AH10, AH11, AH14, AH21, AJ10, AJ11, AJ14, AJ21
VDDA33 (3.3 VOLTS)	F24, F25, G24, G25, K28, K29, L29, P29, P30, U30, AA28, AA29, AD29, AE29, AJ24, AH24, AJ25

12.3 Device package

The SPI Exchange IDT88P8342 device is packaged in a 35 mm by 35 mm 820-ball one millimeter ball pitch thermally-enhanced plastic ball grid array. All balls, whether used or unused, must be soldered to pads.

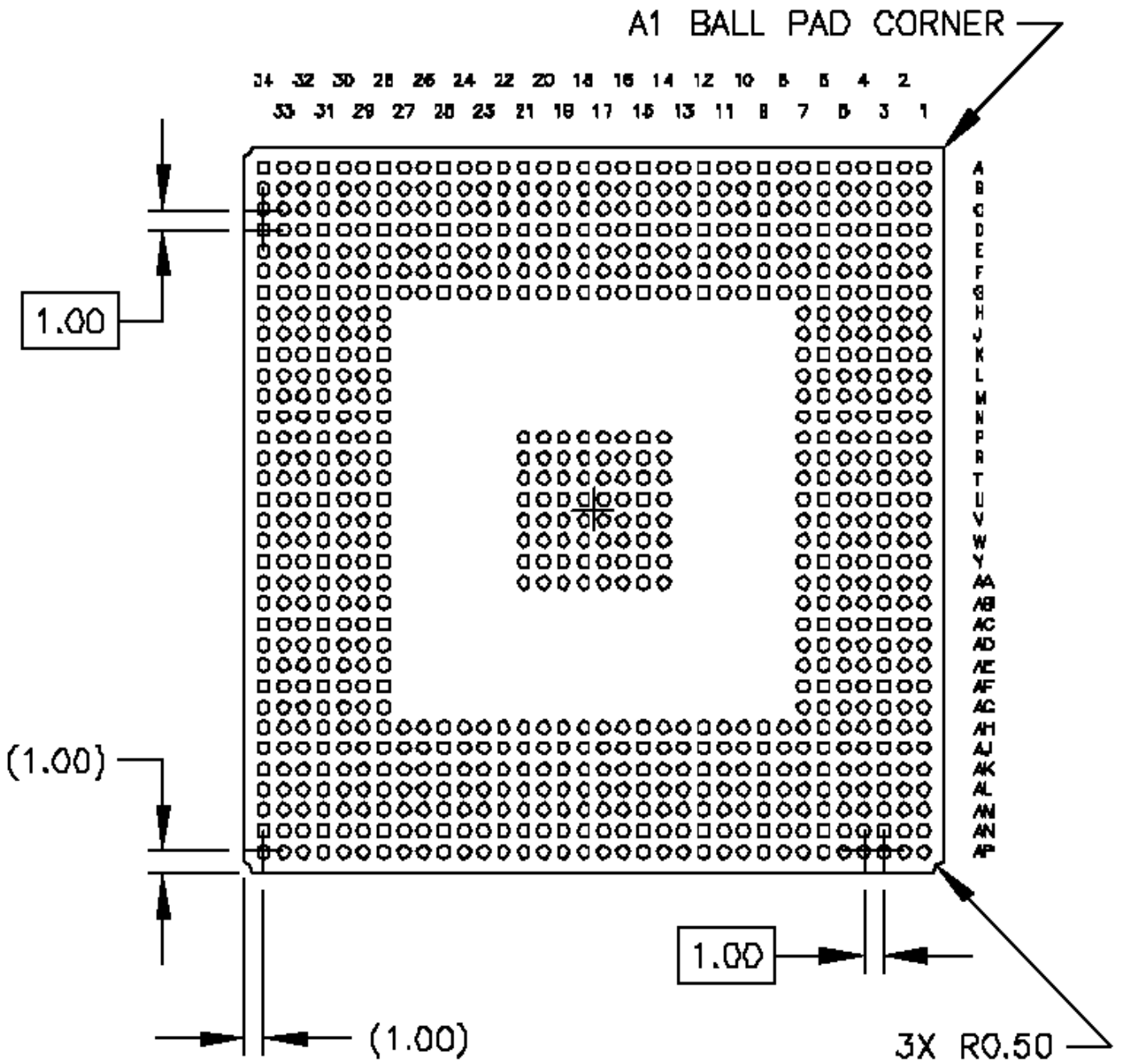
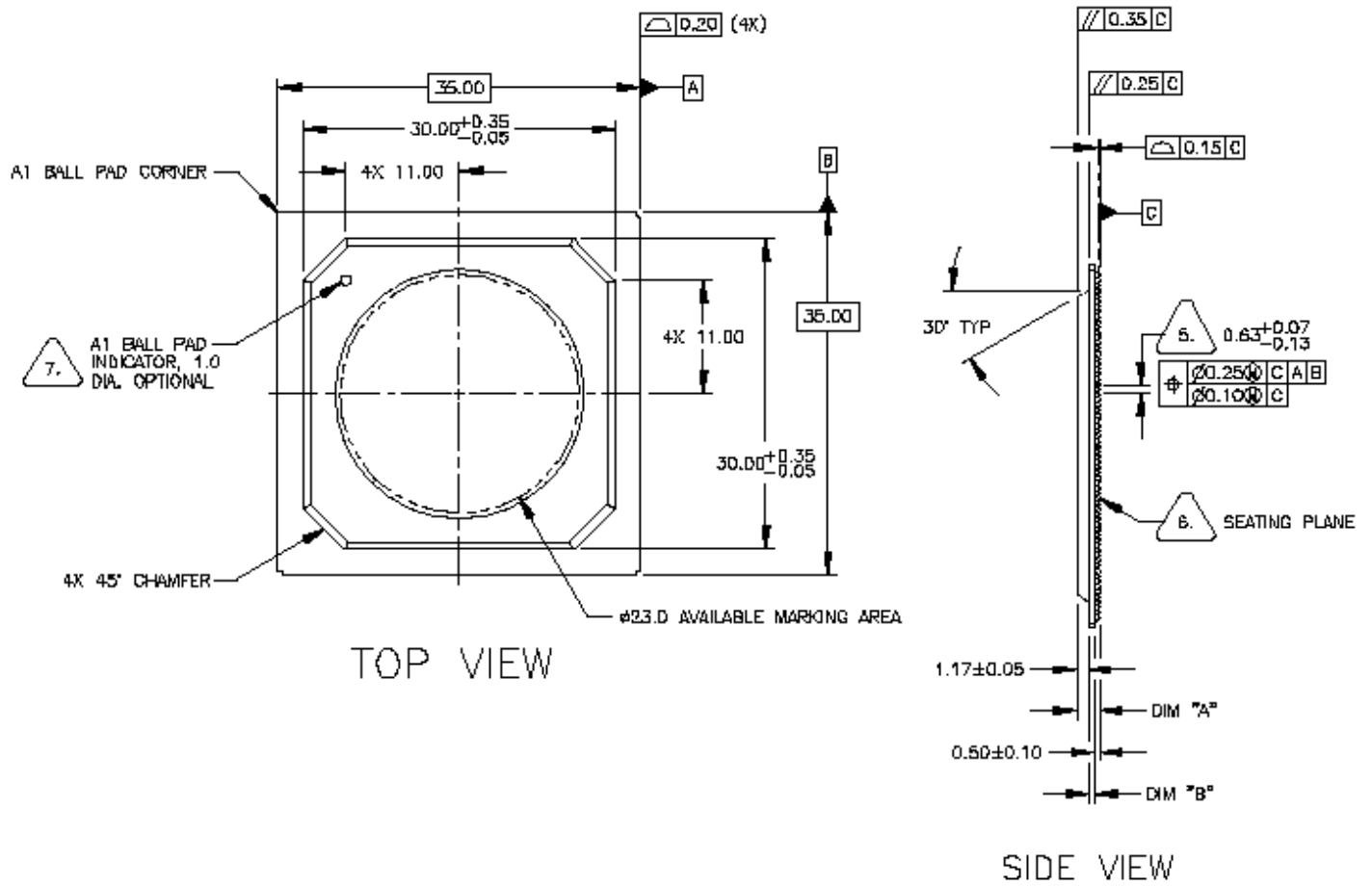

Figure 42. IDT88P8342 820PBGA package, bottom view



4	2.23±0.21	0.56±0.06	STANDARD
NO. LAYERS	DIM "A"	DIM "B"	NOTES
TEPBGA-2 THICKNESS SCHEDULE			

Figure 43. IDT88P8342 820PBGA package, top and side views

13. GLOSSARY

ACRONYM	MEANING
FIFO	First In First Out memory
LID	Logical Identifier See also Logical Port (LP) The entity associated with a flow of data between a SPI-3 LP to a SPI-4 LP, or a SPI-4 LP to a SPI-3 LP.
LP	Logical Port. See also Logical Identifier (LID) The entity associated with a SPI-3 or SPI-4 address.
OIF	Optical Internetworking Forum
SPI-3	System Packet Interface Level 3 This interface is defined by the OIF implementation agreement OIF-SPI3-01.0 - SPI-3 Packet Interface for Physical and Link Layers for OC-48 available at http://www.oiforum.com/public/impagreements.html
SPI-4	System Packet Interface Level 4 phase 2 This interface is defined by the OIF implementation agreement OIF-SPI4-02.1 - System Packet Interface Level 4 (SPI-4) Phase 2: OC-192 System Interface for Physical and Link Layer Devices available at http://www.oiforum.com/public/impagreements.html

14. DATASHEET DOCUMENT REVISION HISTORY

ISSUE	DATE	DESCRIPTION
0.7	05/21/04	<ul style="list-style-type: none"> • General Release
0.8	10/01/04	<ul style="list-style-type: none"> • AG30 ball location changed to SPI4_I_STAT_N[1] and AF31 ball location changed to SPI4_I_STAT_P[0] on Pin name/ball location table (section 12.2) on page 88.
0.9	03/01/05	<ul style="list-style-type: none"> • Updated Chip Configuration Sequence (p. 41) • Update Table 21: "BIT Order Within a 16-BIT Address Register" (p. 45) • Update Table 27: "Indirect Access Address Register" (p. 46) • Updated Direct Access Registers (p. 48-49) • Updated Common Module Indirect Registers (p. 66) • Updated Electrical and Thermal Specification (p. 77) (the section name changed from Electrical Characteristics to Electrical and Thermal Specification). Updated JTAG Instructions. • Added Document Revision History (p. 95)
0.91	05/09/05	<ul style="list-style-type: none"> • Added sections System Reset and Power on Sequence (p.41). • Updated PFR to PFP in Table 49: "Module A/B indirect register" (p.55) • Updated Table 80: "SPI-4 ingress packet length configuration" (p.65) • Updated length for Reserved in Table 83: "SPI-4 ingress port descriptor" (p.65) • Added Green to Ordering information (p.96)
0.92	08/05/05	<ul style="list-style-type: none"> • Updated Table 128: "Absolute maximum ratings" (p.78)
0.93	10/20/05	<ul style="list-style-type: none"> • Updated Table 7: "Parallel microprocessor interface" (p.12) • Updated Table 131: "Thermal Characteristics" (p.79) • Updated Microprocessor parallel port section (p.84-87)
0.94	11/21/05	<ul style="list-style-type: none"> • Updated Table 126: "Version number register (register_offset 0x30)" (p.77)
0.95	01/09/06	<ul style="list-style-type: none"> • Updated Figure 4: "PHY mode SPI-3 ingress interface" (p.14) • Deleted Table 13: "NR_LID Field Encoding". Updated SPI-4 egress queues, Normal operation section (p.26) • Updated Section 8.2.5 "SPI-4 status channel software" (p.43) • Updated Table 127: "Absolute maximum ratings" (p.78) • Updated Table 129: "Terminal Capacitance" (p.79)
1.0	04/10/06	<ul style="list-style-type: none"> • Initial Release of Final Datasheet with new section 8.2.7 "Software Eye-Opening Check on SPI-4" & new Figure 33. "DDR interface and eye opening check through over sampling" (p.44-45) • Updated Clock generator (pg. 39) • Updated SPI-4 ingress watermark register (pg. 71) • Updated Clock generator control register (pg. 77) • Updated Table 130: Thermal Characteristics (pg. 80) • Updated Table 132: SPI-3 AC Input/Output timing specifications (pg. 82) • Updated Table 136: OCLK[3:0] outputs and MCLK internal clock (pg. 84)

15. ORDERING INFORMATION

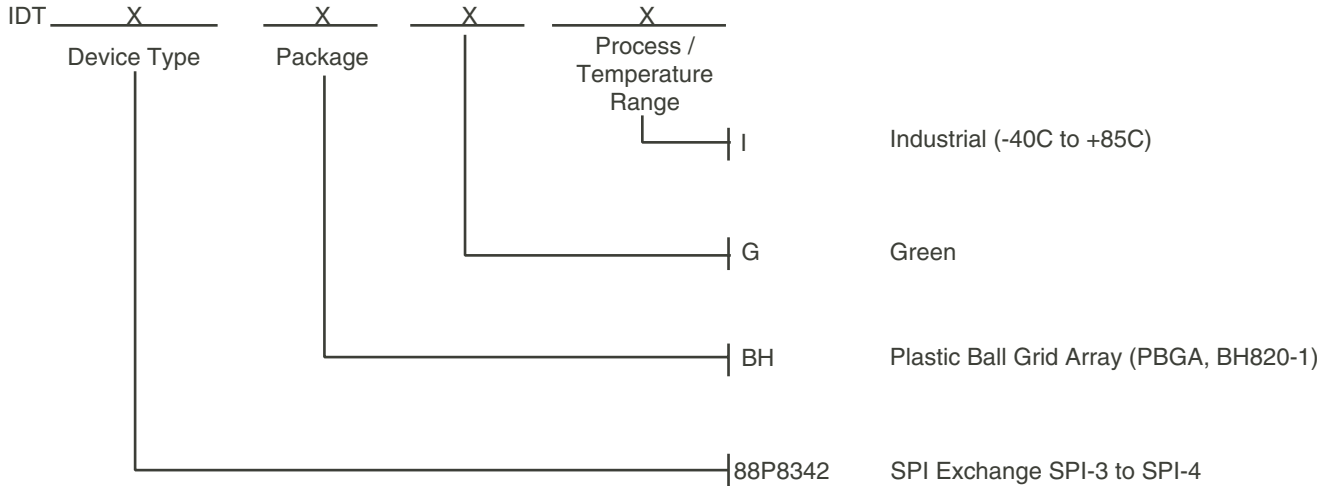

6371 drwlast

NOTE:

1. Green parts are available.



CORPORATE HEADQUARTERS
6024 Silver Creek Valley Road
San Jose, CA 95138

for SALES:
800-345-7015 or 408-284-8200
fax: 408-284-2775
www.idt.com

for Tech Support:
408-360-1716
email: SPI@idt.com

Данный компонент на территории Российской Федерации

Вы можете приобрести в компании MosChip.

Для оперативного оформления запроса Вам необходимо перейти по данной ссылке:

<http://moschip.ru/get-element>

Вы можете разместить у нас заказ для любого Вашего проекта, будь то серийное производство или разработка единичного прибора.

В нашем ассортименте представлены ведущие мировые производители активных и пассивных электронных компонентов.

Нашей специализацией является поставка электронной компонентной базы двойного назначения, продукции таких производителей как XILINX, Intel (ex.ALTERA), Vicor, Microchip, Texas Instruments, Analog Devices, Mini-Circuits, Amphenol, Glenair.

Сотрудничество с глобальными дистрибьюторами электронных компонентов, предоставляет возможность заказывать и получать с международных складов практически любой перечень компонентов в оптимальные для Вас сроки.

На всех этапах разработки и производства наши партнеры могут получить квалифицированную поддержку опытных инженеров.

Система менеджмента качества компании отвечает требованиям в соответствии с ГОСТ Р ИСО 9001, ГОСТ РВ 0015-002 и ЭС РД 009

Офис по работе с юридическими лицами:

105318, г.Москва, ул.Щербаковская д.3, офис 1107, 1118, ДЦ «Щербаковский»

Телефон: +7 495 668-12-70 (многоканальный)

Факс: +7 495 668-12-70 (доб.304)

E-mail: info@moschip.ru

Skype отдела продаж:

moschip.ru

moschip.ru_4

moschip.ru_6

moschip.ru_9