



### Product Brief

The SST12LF02 is a 2.4 GHz Front-End Module (FEM) that combines a high-performance Power Amplifier (PA) and a switch within a compact, fully-matched package. Designed in compliance with IEEE 802.11b/g/n applications and based on GaAs PHEMT/HBT technology, the SST12LF02 operates within the frequency range of 2.4–2.5 GHz with very low DC-current consumption. The Transmitter chain has excellent linearity, typically <3% added EVM up to 18 dBm output power, with 802.11g 54 Mbps OFDM operation while meeting 802.11b/g/n spectrum mask at 21 dBm. An option to simultaneously connect the WLAN and Bluetooth receiver ports is available. The SST12LF02 is offered in a 16-contact XQFN package.

## Features

- **High Gain:**
  - Typically 29 dB gain across 2.4–2.5 GHz over temperature -20°C to +85°C for Transmitter (TX) chain.
- **High linear output power (at 3.3V):**
  - Meets 802.11g OFDM ACPR requirement up to 21 dBm
  - <3% added EVM up to 18 dBm for 54 Mbps 802.11g signal
  - Meets 802.11b ACPR requirement up to 21 dBm
- **High power-added efficiency/Low operating current for 802.11b/g/n applications**
- **High temperature stability**
  - ~1 dB power variation between -20°C to +85°C
  - ~3 dB gain variation between -20°C to +85°C
- **Temperature and load insensitive on-chip power detector**
  - 20 dB dynamic range
- **Low insertion loss**
  - 0.5 dB for WLAN receiver and Bluetooth ports
  - 4.5 dB and 3.8 dB for simultaneous WLAN and Bluetooth receiver ports, respectively
- **Input/output ports matched to 50Ω internally and DC decoupled.**
- **Packages available**
  - 16-contact XQFN – 3mm x 3mm x 0.45mm
- **All non-Pb (lead-free) devices are RoHS compliant**

## Applications

- WLAN (IEEE 802.11b/g/n)
- Bluetooth™
- Home RF
- Cordless phones
- 2.4 GHz ISM wireless equipment

## Block Diagram

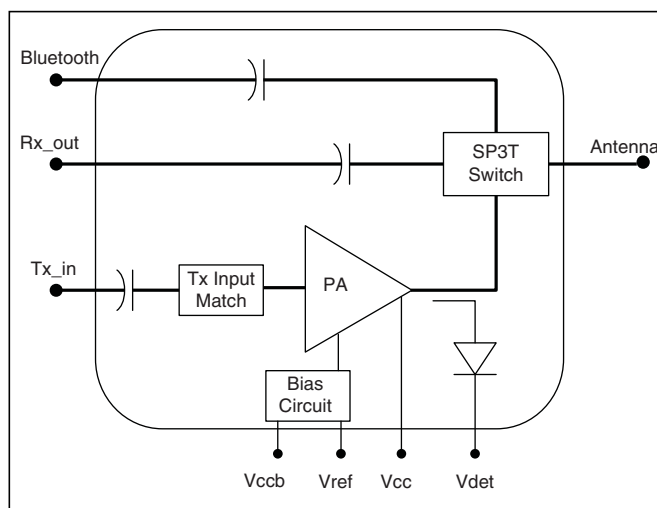

## Product Ordering

### Valid combinations for SST12LF02

SST12LF02-QXCE

### SST12LF02 Evaluation Kits

SST12LF02-QXCE-K

**Note:** Valid combinations are those products in mass production or will be in mass production. Consult your SST sales representative to confirm availability of valid combinations and to determine availability of new combinations.



## Contact Information

Thank you for your interest in Microchip RF products. The data sheet for this device contains proprietary information. To obtain a copy of the data sheet, contact your local Microchip sales representative or distributor at the link below.

### Global Sales and Distribution

**Table 1:**Revision History

Revision	Description	Date
A	<ul style="list-style-type: none"> <li>Initial release of Product Brief</li> </ul>	Apr 2011
B	<ul style="list-style-type: none"> <li>Added Contact Information</li> <li>Modified summary paragraph on page 1.</li> <li>Added "Insertion loss" information to Features on page 1.</li> </ul>	Jun 2011

ISBN:978-1-61341-338-8

© 2011 Silicon Storage Technology, Inc—a Microchip Technology Company. All rights reserved.

SST, Silicon Storage Technology, the SST logo, SuperFlash, MTP, and FlashFlex are registered trademarks of Silicon Storage Technology, Inc. MPF, SQI, Serial Quad I/O, and Z-Scale are trademarks of Silicon Storage Technology, Inc. All other trademarks and registered trademarks mentioned herein are the property of their respective owners.

Specifications are subject to change without notice. Refer to [www.microchip.com](http://www.microchip.com) for the most recent documentation. For the most current package drawings, please see the Packaging Specification located at <http://www.microchip.com/packaging>.

Memory sizes denote raw storage capacity; actual usable capacity may be less.

SST makes no warranty for the use of its products other than those expressly contained in the Standard Terms and Conditions of Sale.

For sales office locations and information, please see [www.microchip.com](http://www.microchip.com).

---

Silicon Storage Technology, Inc.  
A Microchip Technology Company  
[www.microchip.com](http://www.microchip.com)

---

## Данный компонент на территории Российской Федерации

### Вы можете приобрести в компании MosChip.

Для оперативного оформления запроса Вам необходимо перейти по данной ссылке:

<http://moschip.ru/get-element>

Вы можете разместить у нас заказ для любого Вашего проекта, будь то серийное производство или разработка единичного прибора.

В нашем ассортименте представлены ведущие мировые производители активных и пассивных электронных компонентов.

Нашей специализацией является поставка электронной компонентной базы двойного назначения, продукции таких производителей как XILINX, Intel (ex.ALTERA), Vicor, Microchip, Texas Instruments, Analog Devices, Mini-Circuits, Amphenol, Glenair.

Сотрудничество с глобальными дистрибьюторами электронных компонентов, предоставляет возможность заказывать и получать с международных складов практически любой перечень компонентов в оптимальные для Вас сроки.

На всех этапах разработки и производства наши партнеры могут получить квалифицированную поддержку опытных инженеров.

Система менеджмента качества компании отвечает требованиям в соответствии с ГОСТ Р ИСО 9001, ГОСТ РВ 0015-002 и ЭС РД 009

### Офис по работе с юридическими лицами:

105318, г.Москва, ул.Щербаковская д.3, офис 1107, 1118, ДЦ «Щербаковский»

Телефон: +7 495 668-12-70 (многоканальный)

Факс: +7 495 668-12-70 (доб.304)

E-mail: [info@moschip.ru](mailto:info@moschip.ru)

Skype отдела продаж:

moschip.ru

moschip.ru\_4

moschip.ru\_6

moschip.ru\_9