

PIC32 GUI Development Board with Projected Capacitive (PCAP) Touch Information Sheet

Thank you for purchasing a PIC32 GUI Development Board with Projected Capacitive (PCAP) Touch, also referred to as the *PCAP Board*. This information sheet provides some important details that will help you successfully use the board as quickly as possible.

Additional information can be accessed at: <http://www.microchip.com>

Basic Requirements

The PCAP Board is a stand-alone solution that does not require a starter kit or a plug-in module (PIM) to run. The board uses a PIC32MX795F512L microcontroller to control the LCD using Low-Cost Controllerless (LCC) graphics. A capacitive sensing MTCH6301 microcontroller is also on the board to handle the PCAP sensing. The board uses a separate sensor for PCAP that is attached to the LCD.

As an alternate PCAP sensing method, an additional header (J6) on the board enables the use of an LCD with built-in PCAP sensing. It is assumed that an I²C interface will be used for communications. In this case, a driver would need to be added to the software to support this change.

For more information about LCC Graphics visit: <http://www.microchip.com/LCC>

Getting Started

To get started with the PCAP Board, follow these steps:

1. Ensure that MPLAB[®] IDE is installed.
2. Download a project file for the PCAP board from the Microchip website.
3. Power the PCAP board using a USB cable.
4. Connect a debugger/programmer using the PICKit[™] header, J2.
5. Using MPLAB IDE, open the project that was previously downloaded.
6. Select a debugger/programmer in MPLAB IDE.
7. Click **Build**. This builds the downloaded project.
8. Click **Program all memories**.
9. Click **Run**.

Your PCAP Board should now be up and running. On the main screen, which will have a white background, there are icons of demonstrations to choose. These demonstrations showcase some of the features of LCC and the multi-touch features of PCAP.

Americas

Atlanta - 678-957-9614
Boston - 774-760-0087
Chicago - 630-285-0071
Cleveland - 216-447-0464
Dallas - 972-818-7423
Detroit - 248-538-2250
Indianapolis - 317-773-8323
Los Angeles - 949-462-9523
Phoenix - 480-792-7200
Santa Clara - 408-961-6444
Toronto - 905-673-0699

Europe

Austria - Wels - 43-7242-2244-39
Denmark - Copenhagen - 45-4450-2828
France - Paris - 33-1-69-53-63-20
Germany - Munich - 49-89-627-144-0
Italy - Milan - 39-0331-742611
Netherlands - Drunen - 31-416-690399
Spain - Madrid - 34-91-708-08-90
UK - Wokingham - 44-118-921-5869

Asia/Pacific

Australia - Sydney - 61-2-9868-6733
China - Beijing - 86-10-8569-2100
China - Chengdu - 86-28-8665-5511
China - Chongqing - 86-23-8980-9588

Asia/Pacific (Continued)

China - Hangzhou - 86-571-2819-3187
China - Hong Kong SAR - 852-2401-1200
China - Nanjing - 86-25-8473-2460
China - Qingdao - 86-532-8502-7355
China - Shanghai - 86-21-5407-5533
China - Shenyang - 86-24-2334-2829
China - Shenzhen - 86-755-8203-2660
China - Wuhan - 86-27-5980-5300
China - Xiamen - 86-592-2388138
China - Xian - 86-29-8833-7252
China - Zhuhai - 86-756-3210040
India - Bangalore - 91-80-3090-4444
India - New Delhi - 91-11-4160-8631
India - Pune - 91-20-2566-1512
Japan - Osaka - 81-66-152-7160
Japan - Yokohama - 81-45-471-6166
Korea - Daegu - 82-53-744-4301
Korea - Seoul - 82-2-554-7200
Malaysia - Kuala Lumpur - 60-3-6201-9857
Malaysia - Penang - 60-4-227-8870
Philippines - Manila - 63-2-634-9065
Singapore - 65-6334-8870
Taiwan - Hsin Chu - 886-3-5778-366
Taiwan - Kaohsiung - 886-7-536-4818
Taiwan - Taipei - 886-2-2500-6610
Thailand - Bangkok - 66-2-694-1351

11/29/11



Microchip Technology Inc. • 2355 West Chandler Blvd. • Chandler, AZ 85224-6199

www.microchip.com

The Microchip name and logo, the Microchip logo, and MPLAB are registered trademarks of Microchip Technology Incorporated in the U.S.A. and other countries. All other trademarks mentioned herein are property of their respective companies. © 2012, Microchip Technology Incorporated, Printed in the U.S.A. All Rights Reserved. 11/11

DS52089B



PIC32 GUI Development Board with Projected Capacitive (PCAP) Touch Information Sheet

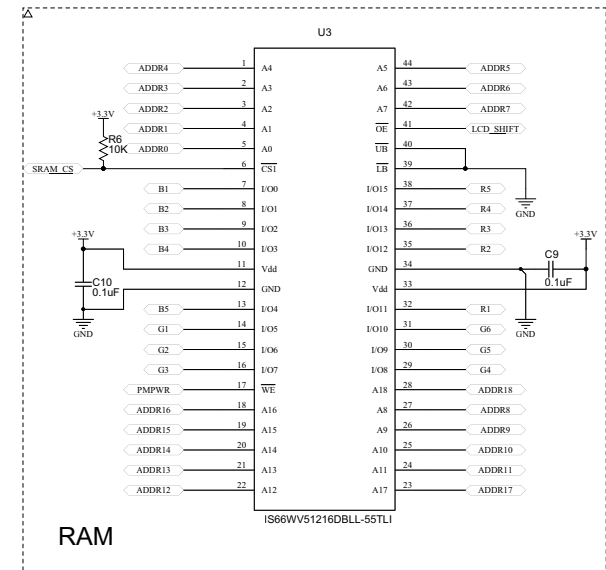
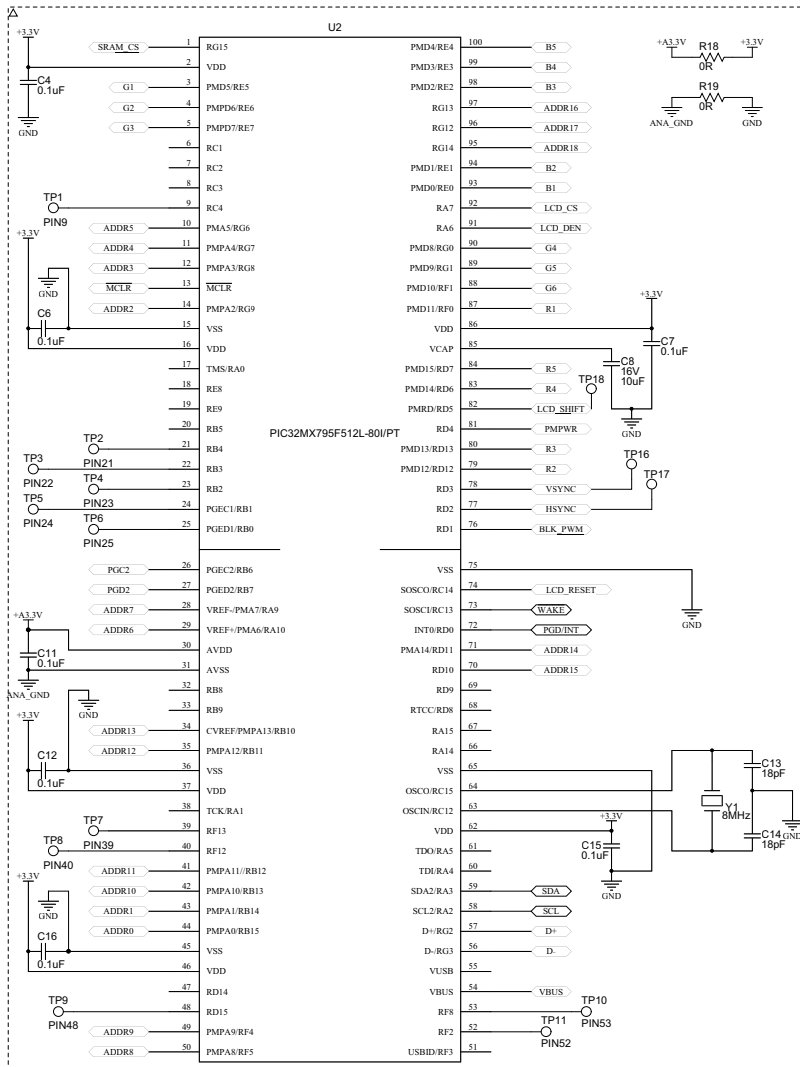
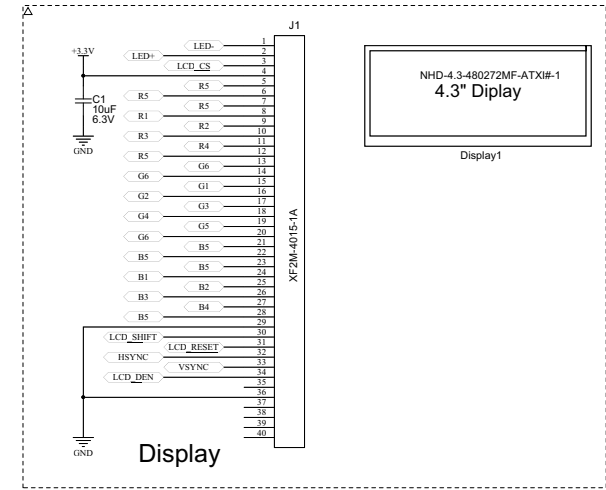
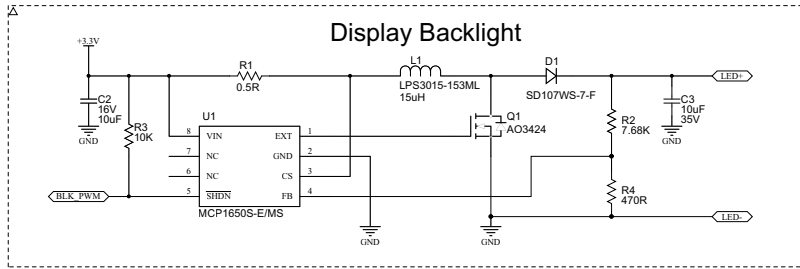

Mouser Electronics

Authorized Distributor

Click to View Pricing, Inventory, Delivery & Lifecycle Information:

[Microchip:](#)

[DM320015](#)

Данный компонент на территории Российской Федерации

Вы можете приобрести в компании MosChip.

Для оперативного оформления запроса Вам необходимо перейти по данной ссылке:

<http://moschip.ru/get-element>

Вы можете разместить у нас заказ для любого Вашего проекта, будь то серийное производство или разработка единичного прибора.

В нашем ассортименте представлены ведущие мировые производители активных и пассивных электронных компонентов.

Нашей специализацией является поставка электронной компонентной базы двойного назначения, продукции таких производителей как XILINX, Intel (ex.ALTERA), Vicor, Microchip, Texas Instruments, Analog Devices, Mini-Circuits, Amphenol, Glenair.

Сотрудничество с глобальными дистрибьюторами электронных компонентов, предоставляет возможность заказывать и получать с международных складов практически любой перечень компонентов в оптимальные для Вас сроки.

На всех этапах разработки и производства наши партнеры могут получить квалифицированную поддержку опытных инженеров.

Система менеджмента качества компании отвечает требованиям в соответствии с ГОСТ Р ИСО 9001, ГОСТ РВ 0015-002 и ЭС РД 009

Офис по работе с юридическими лицами:

105318, г.Москва, ул.Щербаковская д.3, офис 1107, 1118, ДЦ «Щербаковский»

Телефон: +7 495 668-12-70 (многоканальный)

Факс: +7 495 668-12-70 (доб.304)

E-mail: info@moschip.ru

Skype отдела продаж:

moschip.ru

moschip.ru_4

moschip.ru_6

moschip.ru_9