

### Features

- 2:4 Differential Multiplexer/Demultiplexer
- Bidirectional Operation
- Can be used in
  - Single 1:4 Configuration
  - Dual 1:2 Configuration
  - Fan out 1:2 Configuration
- High BW (1.2 GHz Typ)
- Low RON and CON:
  - 13 Ω RON Typ
  - 9 pF CON Typ
- ESD Performance (I/O Pins)
  - ±8-kV Contact Discharge (IEC61000-4-2)
  - 2-kV Human Body Model per JESD22-A114E (to GND)
- ESD Performance (All Pins)
  - 2-kV Human Body Model per JESD22-A114E
- Small QFN package (3 x 3 mm, 0.4 mm pitch)

### Applications

- Desktop/Notebooks Computers
- DisplayPort Auxiliary Channel Multiplexing
- USB 2.0 Multiplexing
- Netbooks/eBooks/Tablets

### Block Diagram

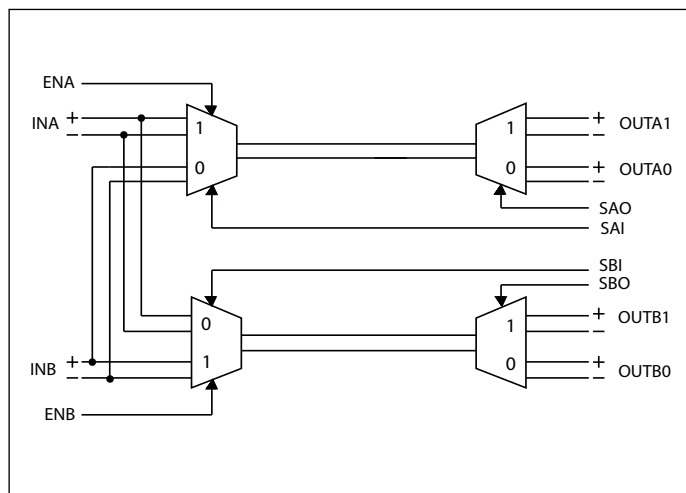

### Description

The PI3DBS3224 is a 2:4 bidirectional multiplexer for high-speed differential and single ended signal applications (up to 720 Mbps). The PI3DBS3224 can be used in a 1:4 or dual 1:2 multiplexer/demultiplexer configuration. The PI3DBS3224 offers a high BW of 1.2 GHz with channel RON of 13 Ω (Typ).

The PI3DBS3224 can also be used to fan out a differential or single ended signal pair to two ports simultaneously (fan-out configuration). The BW performance is lower in this configuration.

The PI3DBS3224 operates with a 3 to 3.6V power supply. It features ESD protection of up to ±8-kV contact discharge and 2-kV Human Body Model on its I/O pins.

The PI3DBS3224 provides fail-safe protection by isolating the I/O pins with high impedance when the power supply (V<sub>CC</sub>) is not present.

### Pin Configuration

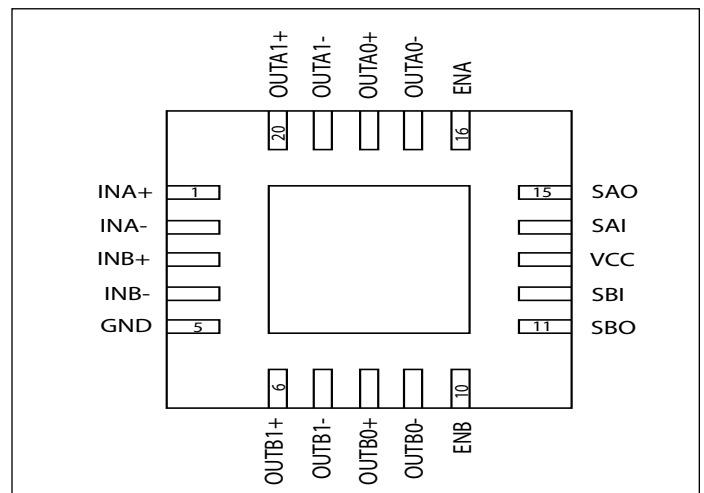

**Pin Description**

Pin #	PIN Name	I/O Type	Description
14	SAI	Input	Control Input
15	SAO	Input	Control Input
12	SBI	Input	Control Input
11	SBO	Input	Control Input
16	ENA	Input	Enable
1	INA+	I/O	Input A
2	INA-	I/O	Input A
10	ENB	Input	Enable
3	INB+	I/O	Input B
4	INB-	I/O	Input B
9	OUTB0-	I/O	Output B0
8	OUTB0+	I/O	Output B0
7	OUTB1-	I/O	Output B1
6	OUTB1+	I/O	Output B1
5	GND	Ground	Ground
13	VCC	Power	Power Supply
17	OUTA0-	I/O	Output A0
18	OUTA0+	I/O	Output A0
19	OUTA1-	I/O	Output A1
20	OUTA1+	I/O	Output A1

**Function Table**

ENA, ENB	OUTA0	OUTA1	OUTB0	OUTB1
00	Hi-Z	Hi-Z	Hi-Z	Hi-Z
01	Hi-Z	Hi-Z	-	-
10	-	-	Hi-Z	Hi-Z
11	-	-	-	-

SAI, SAO, SBI, SBO	OUTA0	OUTA1	OUTB0	OUTB1
0000	INB	-	INA	-
0001	INB	-	-	INA
0010	INB	-	INB	-
0011	INB	-	-	INB
0100	-	INB	INA	-
0101	-	INB	-	INA
0110	-	INB	INB	-
0111	-	INB	-	INB
1000	INA	-	INA	-
1001	INA	-	-	INA
1010	INA	-	INB	-
1011	INA	-	-	INB
1100	-	INA	INA	-
1101	-	INA	-	INA
1110	-	INA	INB	-
1111	-	INA	-	INB

### Maximum Ratings

(Above which useful life may be impaired. For user guidelines, not tested.)

Storage Temperature.....	-65°C to+155°C
Supply Voltage to Ground Potential.....	-0.3V to+4.0V
DC Input Voltage .....	-0.3V to+4.3V
DC Output Current .....	120mA
Power Dissipation .....	0.5W

**Note:**

Stresses greater than those listed under MAXIMUM RATINGS may cause permanent damage to the device. This is a stress rating only and functional operation of the device at these or any other conditions above those indicated in the operational sections of this specification is not implied. Exposure to absolute maximum rating conditions for extended periods may affect reliability.

### DC Electrical Characteristics over Operating Range

For Single 1:4 or Dual 1:2 configurations.  $T_A = -40\text{ }^{\circ}\text{C}$  to  $85\text{ }^{\circ}\text{C}$ , Typical values are at  $V_{CC} = 3.3\text{ V}$ ,  $T_A = 25\text{ }^{\circ}\text{C}$  (unless otherwise noted)

Symbol	Parameter	Test Condition	Min	Typ	Max	Unit
$V_{IK}$	Digital input clamp voltage	$V_{CC} = 3.6\text{ V}$ , $I_I = -18\text{ mA}$	-1.2	-0.9		V
$I_{IN}$	Digital input leakage current	$V_{CC} = 3.6\text{ V}$ , $V_{IN} = 0\text{ to }3.6\text{ V}$			$\pm 2$	$\mu\text{A}$
$I_{OZ}^{(3)}$		$V_{CC} = 3.6\text{ V}$ , $V_O = 0\text{ V to }3.6\text{ V}$ , $V_I = 0\text{ V}$ , Switch OFF			$\pm 2$	$\mu\text{A}$
$I_{OFF}$	Power off leakage current	$V_{CC} = 0\text{ V}$ , $V_{IN} = V_{CC}$ or GND, $V_{I/O} = 0\text{ V to }3.6\text{ V}$			$\pm 8$	$\mu\text{A}$
$I_{CC}$	Supply current	$V_{CC} = 3.6\text{ V}$ , $I_{I/O} = 0$ , Switch ON or OFF		70	130	$\mu\text{A}$
$C_{IN}$	Digital input capacitance	$V_{CC} = 3.3\text{ V}$ , $V_{IN} = V_{CC}$ or GND		3	5	pF
$C_{I/O(OFF)}$	OFF capacitance	$V_{CC} = 3.3\text{ V}$ , $V_{I/O} = 3.3\text{ V}$ or 0, $f = 10\text{ MHz}$ , Switch OFF		6	7	pF
$C_{I/O(ON)}$	ON capacitance	$V_{CC} = 3.3\text{ V}$ , $V_{I/O} = 3.3\text{ V}$ or 0, $f = 10\text{ MHz}$ , Switch ON		9	10	pF
$r_{ON}$	ON state resistance	$V_{CC} = 3.6\text{ V}$ , $V_I = V_{CC}$ , $I_O = -30\text{ mA}$		13	19	$\Omega$
		$V_{CC} = 3.3\text{ V}$ , $V_I = 0.5\text{ V}$ , $I_O = -30\text{ mA}$		10		$\Omega$
$\Delta r_{ON}$	ON state resistance match between channel	$V_{CC} = 3\text{ V}$ , $V_I = 0\text{ to }V_{CC}$ , $I_O = -30\text{ mA}$		2	2.5	$\Omega$
$r_{ON(Flat)}$	ON state resistance flatness	$V_{CC} = 3\text{ V}$ , $V_I = 1.5\text{ V}$ and $V_{CC}$ , $I_O = -30\text{ mA}$		4	6	$\Omega$

**Notes:**

- $V_{IN}$  and  $I_{IN}$  refer to control inputs.  $V_I$ ,  $V_O$ ,  $I_I$  and  $I_O$  refer to data pins.
- All typical values are at  $V_{CC} = 3.3\text{ V}$  (unless otherwise noted),  $T_A = 25\text{ }^{\circ}\text{C}$ .
- For I/O ports, the parameter  $I_{OZ}$  includes the input leakage current.

### Dynamic Characteristics

For Single 1:4 or Dual 1:2 configurations.  $T_A = -40\text{ }^{\circ}\text{C}$  to  $85\text{ }^{\circ}\text{C}$ , Typical values are at  $V_{CC} = 3.3\text{V} \pm 10\%$  and  $T_A = 25\text{ }^{\circ}\text{C}$  (unless otherwise noted)

Symbol	Parameter	Test Condition	Typ	Unit
BW	Bandwidth	$R_L = 50\ \Omega$ , Switch ON	1.2	GHz
$O_{ISO}$	OFF Isolation	$R_L = 50\ \Omega$ , $f = 250\text{ MHz}$	-30	dB
$X_{TALK}$	Crosstalk	$R_L = 50\ \Omega$ , $f = 250\text{ MHz}$	-35	dB

### Switching Characteristics

For Single 1:4 or Dual 1:2 configurations. Over operating range,  $T_A = -40\text{ }^{\circ}\text{C}$  to  $85\text{ }^{\circ}\text{C}$ ,  $V_{CC} = 3.3\text{V} \pm 10\%$ ,  $GND = 0\text{ V}$  (unless otherwise noted)

Symbol	Parameter	Test Condition	Min	Typ	Max	Unit
$t_{pd}^{(1)}$		$R_L = 50\ \Omega$ , $C_L = 2\text{ pF}$		50		ps
$t_{ON}$	SAI/SAO/SBI/SBO to OUTAx/OUTBx	$R_L = 50\ \Omega$ , $C_L = 2\text{ pF}$		40	100	ns
$t_{OFF}$	SAI/SAO/SBI/SBO to OUTAx/OUTBx	$R_L = 50\ \Omega$ , $C_L = 2\text{ pF}$		20	30	ns
$t_{sk(o)}^{(2)}$		$R_L = 50\ \Omega$ , $C_L = 2\text{ pF}$		40		ps
$t_{sk(p)}^{(3)}$		$R_L = 50\ \Omega$ , $C_L = 2\text{ pF}$		40		ps

**Notes:**

- The propagation delay is the calculated RC time constant of the typical ON-State resistance of the switch and the specified load capacitance when driven by an ideal voltage source (zero output impedance).
- Output skew between center channel and any other channel.
- Skew between opposite transitions of the same output ( $|t_{PHL} - t_{PLH}|$ ).

## DC Electrical Characteristics over Operating Range

For fan-out 1:2 configurations.  $T_A = -40\text{ }^{\circ}\text{C}$  to  $85\text{ }^{\circ}\text{C}$ , Typical values are at  $V_{CC} = 3.3\text{V}$ ,  $T_A = 25\text{ }^{\circ}\text{C}$  (unless otherwise noted)

Symbol	Parameter	Test Condition	Min	Typ	Max	Unit
$V_{IK}$	Digital input clamp voltage	$V_{CC} = 3.6\text{ V}$ , $I_I = -18\text{ mA}$	-1.2	-0.9		V
$I_{IN}$	Digital input leakage current	$V_{CC} = 3.6\text{ V}$ , $V_{IN} = 0\text{ to }3.6\text{ V}$			$\pm 2$	$\mu\text{A}$
$I_{OZ}^{(3)}$		$V_{CC} = 3.6\text{ V}$ , $V_O = 0\text{ V to }3.6\text{ V}$ , $V_I = 0\text{ V}$ , Switch OFF			$\pm 2$	$\mu\text{A}$
$I_{OFF}$	Power off leakage current	$V_{CC} = 0\text{ V}$ , $V_{IN} = V_{CC}$ or GND, $V_{I/O} = 0\text{ V to }3.6\text{ V}$			$\pm 8$	$\mu\text{A}$
$I_{CC}$	Supply current	$V_{CC} = 3.6\text{ V}$ , $I_{I/O} = 0$ , Switch ON or OFF		70	130	$\mu\text{A}$
$C_{IN}$	Digital input capacitance	$V_{CC} = 3.3\text{ V}$ , $V_{IN} = V_{CC}$ or GND		3	5	pF
$C_{I/O(OFF)}$	OFF capacitance	$V_{CC} = 3.3\text{ V}$ , $V_{I/O} = 3.3\text{V}$ or 0, $f = 10\text{MHz}$ , Switch OFF		6	7	pF
$C_{I/O(ON)}$	ON capacitance	$V_{CC} = 3.3\text{ V}$ , $V_{I/O} = 3.3\text{V}$ or 0, $f = 10\text{MHz}$ , Switch ON		12	13	pF
$r_{on}$	ON state resistance	$V_{CC} = 3.6\text{ V}$ , $V_I = V_{CC}$ , $I_O = -30\text{ mA}$		13	19	$\Omega$
$\Delta r_{on}$	ON state resistance match between channel	$V_{CC} = 3\text{ V}$ , $V_I = 0\text{ to }V_{CC}$ , $I_O = -30\text{ mA}$		2	2.5	$\Omega$
$r_{on(Flat)}$	ON state resistance flatness	$V_{CC} = 3\text{ V}$ , $V_I = 1.5\text{ V}$ and $V_{CC}$ , $I_O = -30\text{ mA}$		4	6	$\Omega$

### Notes:

- $V_{IN}$  and  $I_{IN}$  refer to control inputs.  $V_I$ ,  $V_O$ ,  $I_I$  and  $I_O$  refer to data pins.
- All typical values are at  $V_{CC} = 3.3\text{V}$  (unless otherwise noted),  $T_A = 25\text{ }^{\circ}\text{C}$ .
- For I/O ports, the parameter  $I_{OZ}$  includes the input leakage current.

## Dynamic Characteristics

For fan-out 1:2 configurations.  $T_A = -40\text{ }^{\circ}\text{C}$  to  $85\text{ }^{\circ}\text{C}$ , Typical values are at  $V_{CC} = 3.3\text{V} \pm 10\%$  and  $T_A = 25\text{ }^{\circ}\text{C}$  (unless otherwise noted)

Symbol	Parameter	Test Condition	Typ	Unit
BW	Bandwidth	$R_L = 50\ \Omega$ , Switch ON	500	MHz
$O_{ISO}$	OFF Isolation	$R_L = 50\ \Omega$ , $f = 250\text{ MHz}$	-30	dB
$X_{TALK}$	Crosstalk	$R_L = 50\ \Omega$ , $f = 250\text{ MHz}$	-35	dB

### Switching Characteristics

For fan-out 1:2 configuration. Over operating range,  $T_A = -40\text{ }^{\circ}\text{C}$  to  $85\text{ }^{\circ}\text{C}$ ,  $V_{CC} = 3.3\text{V} \pm 10\%$ ,  $GND = 0\text{V}$  (unless otherwise noted)

Symbol	Parameter	Test Condition	Min	Typ	Max	Unit
$t_{pd}^{(1)}$		$R_L = 50\ \Omega$ , $C_L = 2\text{ pF}$		140		ps
$t_{ON}$	SAI/SAO/SBI/SBO to OUTAx/OUTBx	$R = 50\ \Omega$ , $C_L = 2\text{ pF}$		40	100	ns
$t_{OFF}$	SAI/SAO/SBI/SBO to OUTAx/OUTBx	$R_{LL} = 50\ \Omega$ , $C_L = 2\text{ pF}$		20	30	ns
$t_{sk(o)}^{(2)}$		$R_L = 50\ \Omega$ , $C_L = 2\text{ pF}$		60		ps
$t_{sk(p)}^{(3)}$		$R_L = 50\ \Omega$ , $C_L = 2\text{ pF}$		60		ps

**Notes:**

1. The propagation delay is the calculated RC time constant of the typical ON-State resistance of the switch and the specified load capacitance when driven by an ideal voltage source (zero output impedance).
2. Output skew between center channel and any other channel.
3. Skew between opposite transitions of the same output ( $|t_{PHL} - t_{PLH}|$ ).

### DC Electrical Characteristics over Operating Range

$T_A = -40\text{ }^{\circ}\text{C}$  to  $85\text{ }^{\circ}\text{C}$ , Typical values are at  $V_{CC} = 3.3\text{V}$ ,  $T_A = 25\text{ }^{\circ}\text{C}$

Symbol	Parameter	Test Condition	Min	Typ	Max	Unit
$V_{IO}$	Analog I/O voltage		0		$V_{CC}$	V
$V_{IH}$	High level input control voltage	ENx, SAx, SBx Pins	$0.75V_{CC}$		$V_{CC}$	V
$V_{IL}$	Low level input control voltage	ENx, SAx, SBx Pins	0		0.6	V
$V_{CC}$	Supply voltage		3.0		3.6	V

**Test Circuit For Electrical Characteristics**

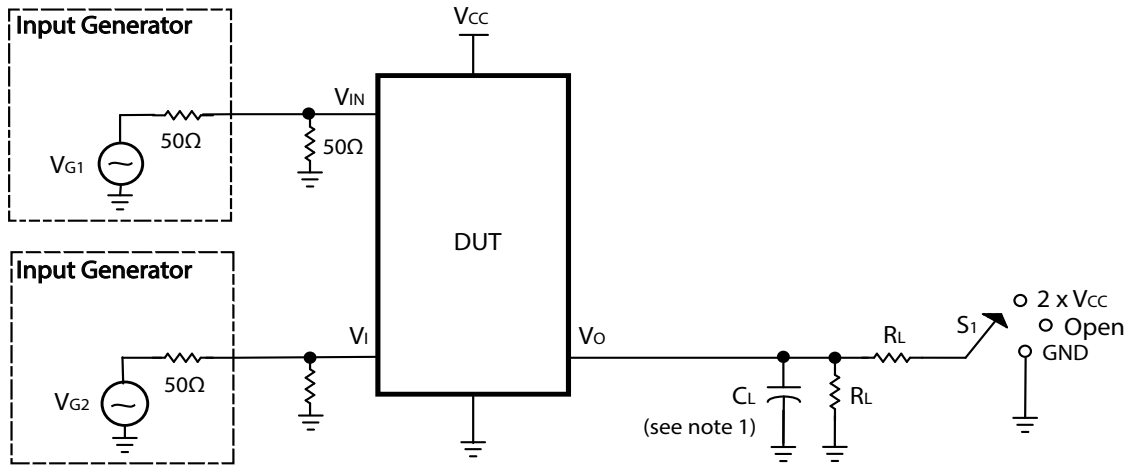

TEST	V <sub>CC</sub>	S1	R <sub>L</sub>	V <sub>in</sub>	C <sub>L</sub>	V <sub>Δ</sub>
t <sub>PLZ</sub> /t <sub>PZL</sub>	3.3 V ± 0.3 V	2 x V <sub>CC</sub>	50Ω	GND	2 pF	0.3 V
t <sub>PHZ</sub> /t <sub>PZH</sub>	3.3 V ± 0.3 V	GND	50Ω	V <sub>CC</sub>	2pF	0.3 V

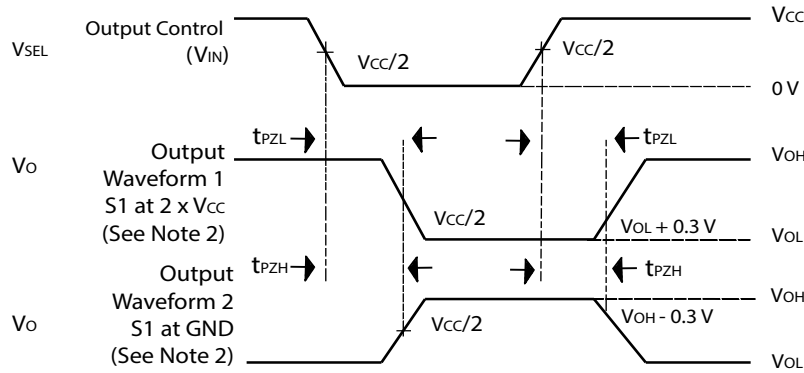

VOLTAGE WAVEFORMS  
ENABLE AND DISABLE TIME

**Notes:**

1. C<sub>L</sub> includes probe and jig capacitance.
2. Waveform 1 is for an output with internal conditions such that the output is low, except when disabled by the output control. Waveform 2 is for an output with internal conditions such that the output is high, except when disabled by the output control.
3. All input pulses are supplied by generators having the following characteristics: PRR ≤ 10 MHz, Z<sub>O</sub> = 50 Ω, t<sub>r</sub> ≤ 2.5 ns, t<sub>f</sub> ≤ 2.5 ns.
4. The outputs are measured one at a time, with one transition per measurement.
5. t<sub>PLZ</sub> and t<sub>PHZ</sub> are the same as t<sub>OFF</sub>.
6. t<sub>PZL</sub> and t<sub>PZH</sub> are the same as t<sub>ON</sub>.



**Test Circuit For Electrical Characteristics**

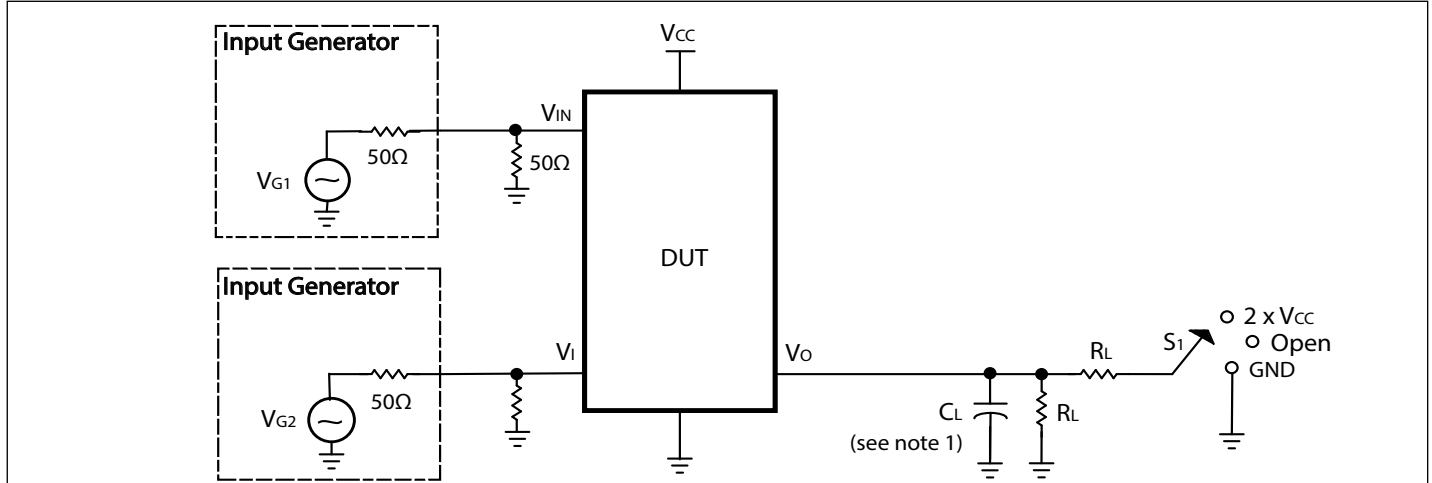

TEST	V <sub>CC</sub>	S1	R <sub>L</sub>	V <sub>in</sub>	C <sub>L</sub>
t <sub>sk(o)</sub>	3.3 V ± 0.3 V	Open	50Ω	V <sub>CC</sub> or GND	2 pF
t <sub>sk(p)</sub>	3.3 V ± 0.3 V	Open	50Ω	V <sub>CC</sub> or GND	2pF

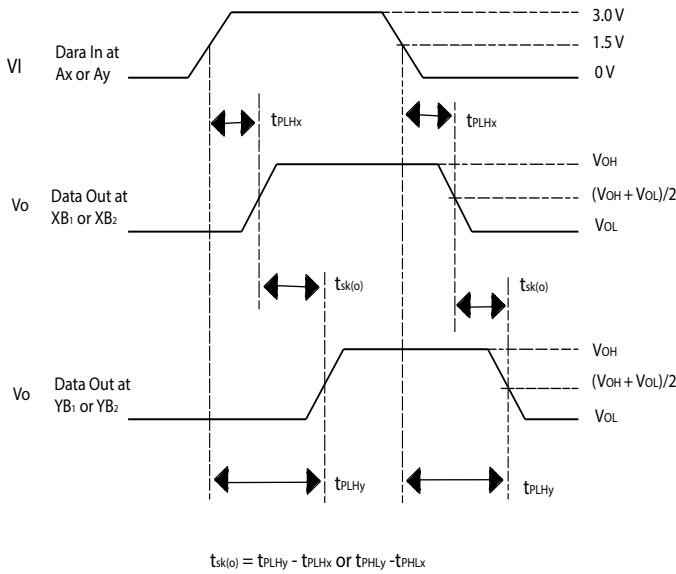

VOLTAGE WAVEFORMS  
OUTPUT SKEW [t<sub>sk(o)</sub>]

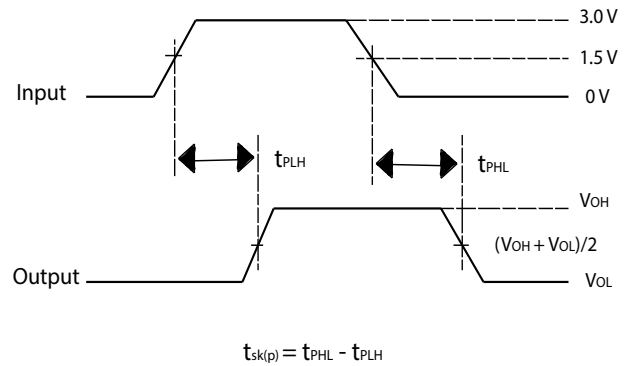

VOLTAGE WAVEFORMS  
PULSE SKEW [t<sub>sk(p)</sub>]

**Notes:**

- C<sub>L</sub> includes probe and jig capacitance.
- All input pulses are supplied by generators having the following characteristics: PRR ≤ 10 MHz, Z<sub>O</sub> = 50 Ω, t<sub>r</sub> ≤ 2.5 ns, t<sub>f</sub> ≤ 2.5 ns.
- The outputs are measured one at a time, with one transition per measurement.

**Packaging Mechanical: 20-pin TQFN (ZNA)**

SYMBOLS	MIN.	NOM.	MAX.
A	0.70	0.75	0.80
A1	0.00	0.02	0.05
A3	0.203 REF.		
b	0.15	0.20	0.25
D	2.95	3.00	3.05
E	2.95	3.00	3.05
D2	1.55	1.65	1.75
E2	1.55	1.65	1.75
L	0.30	0.40	0.50
e	0.40 BSC		

**Notes:**  
 1. All dimensions are in mm. Angles in degrees.  
 2. Refer JEDEC MO-220.  
 3. Recommended land pattern is for reference only.

**PERICOM**  
Enabling Serial Connectivity

DATE: 09/19/13

DESCRIPTION: 20-contact, Thin Fine Pitch Quad Flat No lead Package (TQFN)

PACKAGE CODE: ZNA

DOCUMENT CONTROL #: PD-2169

REVISION: --

13-0240

**Ordering Information**

Ordering Code	Packaging Code	Package Description
PI3DBS3224ZNAE	ZNA	20-contact, Thin Fine Pitch Quad Flat No Lead Package (TQFN)

**Notes:**

- Thermal characteristics can be found on the company web site at [www.pericom.com/packaging/](http://www.pericom.com/packaging/)
- "E" denotes Pb-free and Green
- Adding an "X" at the end of the ordering code denotes tape and reel packaging

# Mouser Electronics

Authorized Distributor

Click to View Pricing, Inventory, Delivery & Lifecycle Information:

[Diodes Incorporated:](#)

[PI3DBS3224ZNAEX](#)

## Данный компонент на территории Российской Федерации

### Вы можете приобрести в компании MosChip.

Для оперативного оформления запроса Вам необходимо перейти по данной ссылке:

<http://moschip.ru/get-element>

Вы можете разместить у нас заказ для любого Вашего проекта, будь то серийное производство или разработка единичного прибора.

В нашем ассортименте представлены ведущие мировые производители активных и пассивных электронных компонентов.

Нашей специализацией является поставка электронной компонентной базы двойного назначения, продукции таких производителей как XILINX, Intel (ex.ALTERA), Vicor, Microchip, Texas Instruments, Analog Devices, Mini-Circuits, Amphenol, Glenair.

Сотрудничество с глобальными дистрибьюторами электронных компонентов, предоставляет возможность заказывать и получать с международных складов практически любой перечень компонентов в оптимальные для Вас сроки.

На всех этапах разработки и производства наши партнеры могут получить квалифицированную поддержку опытных инженеров.

Система менеджмента качества компании отвечает требованиям в соответствии с ГОСТ Р ИСО 9001, ГОСТ РВ 0015-002 и ЭС РД 009

### Офис по работе с юридическими лицами:

105318, г.Москва, ул.Щербаковская д.3, офис 1107, 1118, ДЦ «Щербаковский»

Телефон: +7 495 668-12-70 (многоканальный)

Факс: +7 495 668-12-70 (доб.304)

E-mail: [info@moschip.ru](mailto:info@moschip.ru)

Skype отдела продаж:

moschip.ru

moschip.ru\_4

moschip.ru\_6

moschip.ru\_9