

Digital I/O Units

GT1-□D16(-1)/□D16MX(-1)/□D16ML(-1)/□D32ML(-1)/□D16DS(-1)

Digital I/O Units Compatible with MULTIPLE I/O TERMINAL

- Terminal block, connector, and high-density connector models are available.
- The circuit block of the terminal block model can be mounted or dismantled for ease of maintenance without disconnecting the wires.
- DIN track mounting.



Ordering Information

Unit	I/O classification	Internal I/O common	I/O points	I/O connections	Power supply voltage	I/O specification	Model			
Terminal block model	Digital input	NPN (+ common)	16	M3 terminal board	24 VDC	DC/transistor	GT1-ID16			
		PNP (- common)					GT1-ID16-1			
	Digital output	NPN (- common)				GT1-OD16				
		PNP (+ common)				GT1-OD16-1				
Connector model	Digital input	NPN (+ common)		Molex connector		24 VDC	DC/transistor	GT1-ID16MX		
		PNP (- common)						GT1-ID16MX-1		
	Digital output	NPN (- common)					GT1-OD16MX			
		PNP (+ common)					GT1-OD16MX-1			
	Digital input	NPN (+ common)	Fujitsu connector		DC/transistor		GT1-ID16ML			
		PNP (- common)					GT1-ID16ML-1			
	Digital output	NPN (- common)		GT1-OD16ML						
		PNP (+ common)		GT1-OD16ML-1						
	High-density connector model	Digital input		NPN (+ common)	32		D-sub 25-pin connector	24 VDC	DC/transistor	GT1-ID16DS
				PNP (- common)						GT1-ID16DS-1
		Digital output	NPN (- common)	GT1-OD16DS						
			PNP (+ common)	GT1-OD16DS-1						
High-density connector model	Digital input	NPN (+ common)	32	Fujitsu connector		24 VDC	DC/transistor		GT1-ID32ML	
		PNP (- common)							GT1-ID32ML-1	
	Digital output	NPN (- common)					GT1-OD32ML			
		PNP (+ common)					GT1-OD32ML-1			

## General Specifications

<b>I/O power supply voltage</b>	20.4 to 26.4 VDC (24 VDC -15%/+10%)		
<b>Current consumption *</b>	Model	I/O Interface	Internal circuit
	GT1-ID16(-1)	35 mA max.	--
	GT1-OD16(-1)	35 mA max.	9 mA max.
	GT1-ID16MX(-1)	35 mA max.	--
	GT1-OD16MX(-1)	35 mA max.	9 mA max.
	GT1-ID16ML(-1)	35 mA max.	--
	GT1-OD16ML(-1)	35 mA max.	9 mA max.
	GT1-ID16DS(-1)	35 mA max.	--
	GT1-OD16DS(-1)	35 mA max.	9 mA max.
	GT1-ID32ML(-1)	55 mA max.	--
GT1-OD32ML(-1)	65 mA max.	11 mA max.	
<b>Dielectric strength</b>	500 VAC		
<b>Noise immunity</b>	Conforms to IEC61000-4-4 2 kV (power line)		
<b>Vibration resistance</b>	10 to 150 Hz, 1.0-mm double amplitude or 70 m/s <sup>2</sup>		
<b>Shock resistance</b>	200 m/s <sup>2</sup>		
<b>Mounting method</b>	DIN 35 mm-track mounting		
<b>Mounting strength</b>	No damage when 100 N pull load was applied in all directions (10 N min. in the DIN track direction)		
<b>Terminal strength</b>	No damage when 100 N pull load was applied		
<b>Screw tightening torque</b>	0.3 to 0.5 N·m		
<b>Ambient operating temperature</b>	-10°C to 55°C (with no icing or condensation)		
<b>Ambient operating humidity</b>	25% to 85% (with no icing or condensation)		
<b>Ambient storage temperature</b>	-25°C to 65°C		
<b>Accessories</b>	I/O Unit Connecting Cable (40 mm)		

\* The above current consumption is a value with all 16 and 32 points turned ON excluding the current consumption of the external sensor connected to the Input Unit and the current consumption of the load connected to the Output Unit.

## Applicable Connectors

Type		Model	Remarks	
Molex connector	Solderless terminal	Housing	51030-0330	
		Chain terminal	70058-0004	Corresponding to 24 to 30 AWG
			70058-0022	Corresponding to 22 to 24 AWG
		Loose terminal	70058-0204	Corresponding to 24 to 30 AWG
			70058-0272	Corresponding to 22 to 24 AWG
		Press-fit tool	57036-5000	Corresponding to 22 to 26 AWG
57037-5000	Corresponding to 24 to 30 AWG			
Fujitsu connector (16 points)	Solder terminal	FCN361J024-AU		
	Press-fit terminal	FCN367J024-AU/F		
	Solderless terminal	FCN363J024-AU		
Fujitsu connector (32 points)	Solder terminal	FCN361J040-AU		
	Press-fit terminal	FCN367J040-AU/F		
	Solderless terminal	FCN363J040-AU		
OMRON D-sub Connector	Plug	XM2A-2501		
	Hood	XM2S-2513	#4-40UNC inch screws	

### Cables with High-density Connectors (Fujitsu-compatible Connectors)

I/O classification	Model
Digital input (16 points)	XW2Z-□□□A
	G79-□C
Digital output (16 points)	XW2Z-□□□A
	G79-□C
Digital input (32 points)	XW2Z-□□□B
	G79-□C□
Digital output (32 points)	XW2Z-□□□B
	G79-□C□

Note: Refer to page 162 for ordering information.

## Input Specifications

Item	Model	GT1-ID□□
<b>ON delay</b>		1.5 ms max.
<b>OFF delay</b>		1.5 ms max.
<b>ON voltage</b>		15 V min. (between each input terminal and V or G)
<b>OFF voltage</b>		5 V max. (between each input terminal and V or G)
<b>OFF current</b>		1 mA max.
<b>Insulation method</b>		Photocoupler
<b>Input indicators</b>		LED (yellow)

## Output Specifications

Item	Model	GT1-OD□□
<b>Rated output current</b>		0.5 A/point *
<b>ON delay</b>		0.5 ms max.
<b>OFF delay</b>		1.0 ms max.
<b>Residual voltage</b>		1.2 V max.
<b>Leakage current</b>		0.1 mA max.
<b>Insulation method</b>		Photocoupler
<b>Output indicators</b>		LED (yellow)

\* Ensure that the total external load current does not exceed the values given in the following table.

Model	Total external load current
GT1-OD16/16MX/32ML(-1)	4 A
GT1-OD16ML/16DS(-1)	2.5 A

## Cables for I/O Connector

### Cables for Connector Terminal Conversion Units (16 Points)

I/O classification	Model	Applicable cable	Connectable model	Remarks
Digital input (16 points)	GT1-ID16ML(-1)	XW2Z-□□□A	XW2D-20G6	Slim-type Connector Terminal Conversion Unit
			XW2E-20G5-IN16	Common terminal (3-tier input type)
Digital output (16 points)	GT1-OD16ML(-1)		XW2D-20G6	Slim-type Connector Terminal Conversion Unit

### Cables for Connector Terminal Conversion Units (32 Points)

I/O classification	Model	Applicable cable	Connectable model	Remarks
Digital input (32 points)	GT1-ID32ML(-1)	XW2Z-□□□B	XW2D-40G6	Slim-type Connector Terminal Conversion Unit
Digital output (32 points)	GT1-OD32ML(-1)			

### Cables for I/O Blocks (16 Points)

I/O classification	Model	Applicable cable	Connectable model	Remarks
Digital input (16 points) NPN	GT1-ID16ML	G79-□C	G7TC-ID16 G7TC-IA16	For I/O Block input
Digital input (16 points) PNP	GT1-ID16ML-1		G7TC-ID16-1 G7TC-IA16-1	For I/O Block output
Digital output (16 points) NPN	GT1-OD16ML		G7TC-OC16 G7TC-OC08 G70D-SOC16 G70D-FOM16 G70D-VSOC16 G70D-VFOM16 G70A-ZOC16-3	For I/O Block output
			M7E Series M7F-□N□□□	Digital Display Unit
Digital output (16 points) PNP	GT1-OD16ML-1		G7TC-OC16-1 G70D-SOC16-1 G70A-ZOC16-4	For I/O Block output
		M7E-01MB□-□□ M7F-□P□□□	Digital Display Unit	

### Cables for I/O Blocks (32 Points)

I/O classification	Model	Applicable cable	Connectable model	Remarks
Digital input (32 points) NPN	GT1-ID32ML	G79-I□C-□	G7TC-ID16 G7TC-IA16	For I/O Block input
Digital input (32 points) PNP	GT1-ID32ML-1		G7TC-ID16-1 G7TC-IA16-1	For I/O Block input
Digital output (32 points) NPN	GT1-OD32ML	G79-O□C-□	G7TC-OC16 G7TC-OC08 G70D-SOC16 G70D-FOM16 G70D-VSOC16 G70D-VFOM16 G70A-ZOC16-3	For I/O Block output
			G7TC-OC16-1 G70D-SOC16-1 G70D-FOM16-1 G70A-ZOC16-4	For I/O Block output

**Note:** For details of applicable cables and connectors, refer to pages 162 to 163.

## Dimensions

### ● Terminal Block Model

- GT1-ID16
- GT1-ID16-1
- GT1-OD16
- GT1-OD16-1



Note: Accessory cable included.

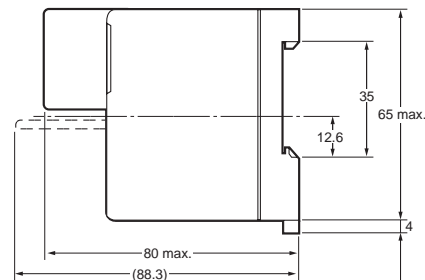

### ● Connector Model

- GT1-ID16MX
- GT1-ID16MX-1
- GT1-OD16MX
- GT1-OD16MX-1



Note: Accessory cable included.

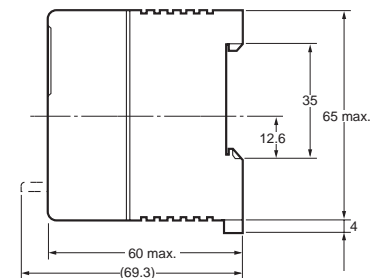

### ● Connector Model

- GT1-ID16ML
- GT1-ID16ML-1
- GT1-OD16ML
- GT1-OD16ML-1



Note: Accessory cable included.

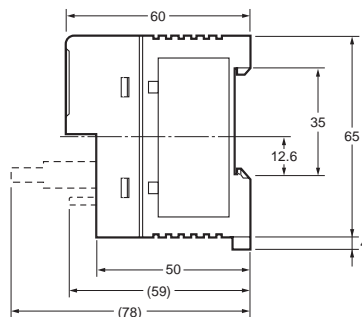

### ● Connector Model

- GT1-ID16DS
- GT1-ID16DS-1
- GT1-OD16DS
- GT1-OD16DS-1



Note: Accessory cable included.

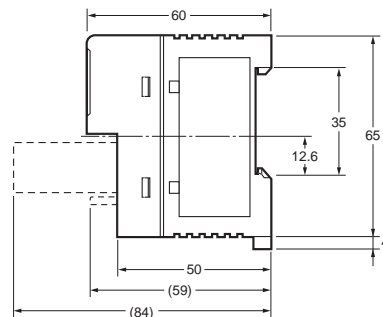

### ● High-density Connector Model

- GT1-ID32ML
- GT1-ID32ML-1
- GT1-OD32ML
- GT1-OD32ML-1



Note: Accessory cable included.

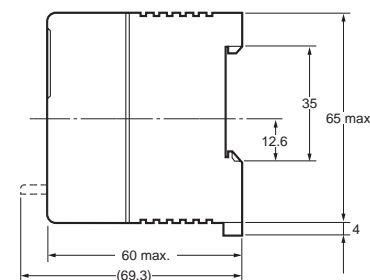

# Wiring Diagrams

**GT1-ID16**

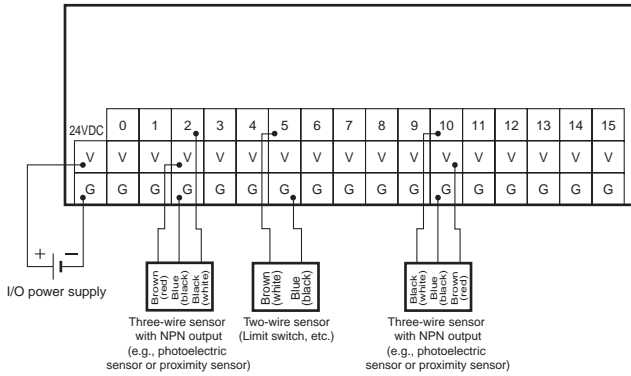

**GT1-ID16-1**

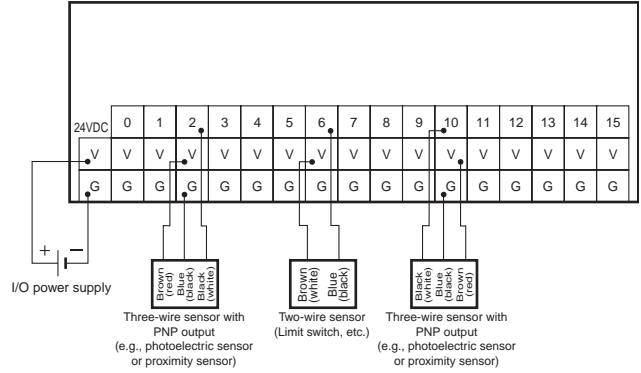

**GT1-OD16**

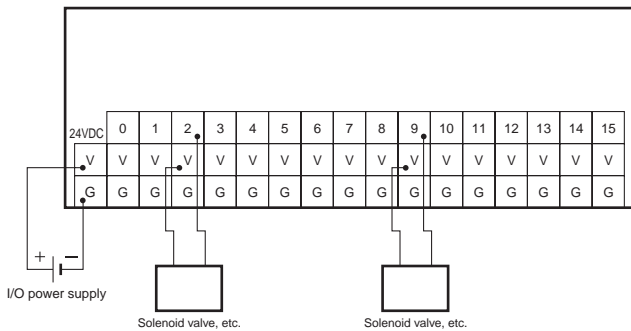

**GT1-OD16-1**

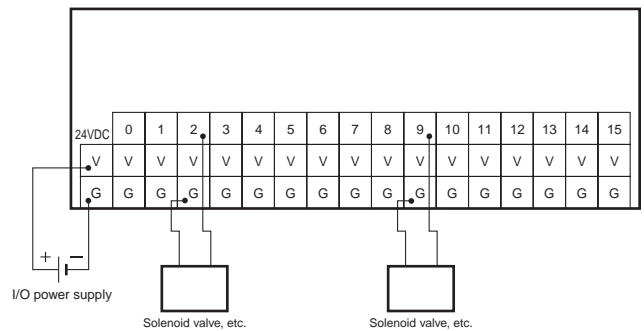

**GT1-ID16MX**



**GT1-ID16MX-1**



**GT1-OD16MX**

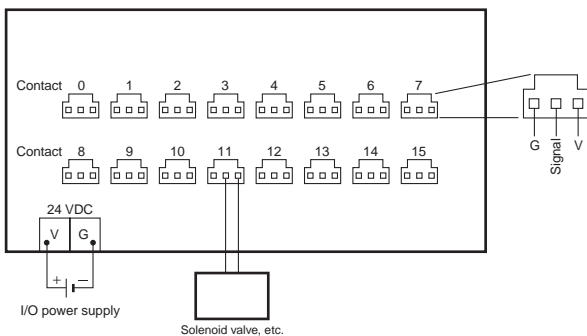

**GT1-OD16MX-1**

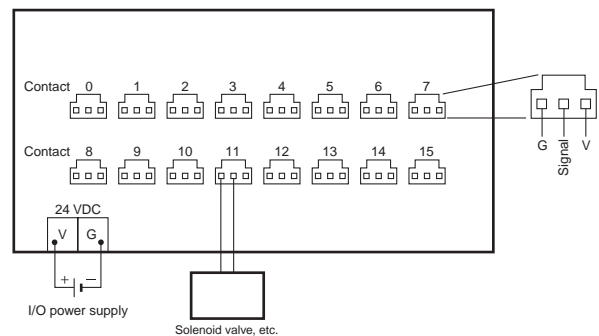

**GT1-ID16ML**



**GT1-ID16ML-1**



**GT1-OD16ML**



**GT1-OD16ML-1**



**GT1-ID16DS**



**GT1-ID32ML**



**GT1-ID16DS-1**



**GT1-ID32ML-1**



**GT1-OD16DS**



**GT1-OD32ML**



**GT1-OD16DS-1**



**GT1-OD32ML-1**



## Данный компонент на территории Российской Федерации

### Вы можете приобрести в компании MosChip.

Для оперативного оформления запроса Вам необходимо перейти по данной ссылке:

<http://moschip.ru/get-element>

Вы можете разместить у нас заказ для любого Вашего проекта, будь то серийное производство или разработка единичного прибора.

В нашем ассортименте представлены ведущие мировые производители активных и пассивных электронных компонентов.

Нашей специализацией является поставка электронной компонентной базы двойного назначения, продукции таких производителей как XILINX, Intel (ex.ALTERA), Vicor, Microchip, Texas Instruments, Analog Devices, Mini-Circuits, Amphenol, Glenair.

Сотрудничество с глобальными дистрибьюторами электронных компонентов, предоставляет возможность заказывать и получать с международных складов практически любой перечень компонентов в оптимальные для Вас сроки.

На всех этапах разработки и производства наши партнеры могут получить квалифицированную поддержку опытных инженеров.

Система менеджмента качества компании отвечает требованиям в соответствии с ГОСТ Р ИСО 9001, ГОСТ РВ 0015-002 и ЭС РД 009

### Офис по работе с юридическими лицами:

105318, г.Москва, ул.Щербаковская д.3, офис 1107, 1118, ДЦ «Щербаковский»

Телефон: +7 495 668-12-70 (многоканальный)

Факс: +7 495 668-12-70 (доб.304)

E-mail: [info@moschip.ru](mailto:info@moschip.ru)

Skype отдела продаж:

moschip.ru

moschip.ru\_4

moschip.ru\_6

moschip.ru\_9