

VC709 Evaluation Board for the Virtex-7 FPGA

User Guide

UG887 (v1.6) March 11, 2019



Please Read: Important Legal Notices

The information disclosed to you hereunder (the "Materials") is provided solely for the selection and use of Xilinx products. To the maximum extent permitted by applicable law: (1) Materials are made available "AS IS" and with all faults, Xilinx hereby DISCLAIMS ALL WARRANTIES AND CONDITIONS, EXPRESS, IMPLIED, OR STATUTORY, INCLUDING BUT NOT LIMITED TO WARRANTIES OF MERCHANTABILITY, NON-INFRINGEMENT, OR FITNESS FOR ANY PARTICULAR PURPOSE; and (2) Xilinx shall not be liable (whether in contract or tort, including negligence, or under any other theory of liability) for any loss or damage of any kind or nature related to, arising under, or in connection with, the Materials (including your use of the Materials), including for any direct, indirect, special, incidental, or consequential loss or damage (including loss of data, profits, goodwill, or any type of loss or damage suffered as a result of any action brought by a third party) even if such damage or loss was reasonably foreseeable or Xilinx had been advised of the possibility of the same. Xilinx assumes no obligation to correct any errors contained in the Materials or to notify you of updates to the Materials or to product specifications. You may not reproduce, modify, distribute, or publicly display the Materials without prior written consent. Certain products are subject to the terms and conditions of Xilinx's limited warranty, please refer to Xilinx's Terms of Sale which can be viewed at <https://www.xilinx.com/legal.htm#tos>. IP cores may be subject to warranty and support terms contained in a license issued to you by Xilinx. Xilinx products are not designed or intended to be fail-safe or for use in any application requiring fail-safe performance; you assume sole risk and liability for use of Xilinx products in such critical applications, please refer to Xilinx's Terms of Sale which can be viewed at <https://www.xilinx.com/legal.htm#tos>.

AUTOMOTIVE APPLICATIONS DISCLAIMER

AUTOMOTIVE PRODUCTS (IDENTIFIED AS "XA" IN THE PART NUMBER) ARE NOT WARRANTED FOR USE IN THE DEPLOYMENT OF AIRBAGS OR FOR USE IN APPLICATIONS THAT AFFECT CONTROL OF A VEHICLE ("SAFETY APPLICATION") UNLESS THERE IS A SAFETY CONCEPT OR REDUNDANCY FEATURE CONSISTENT WITH THE ISO 26262 AUTOMOTIVE SAFETY STANDARD ("SAFETY DESIGN"). CUSTOMER SHALL, PRIOR TO USING OR DISTRIBUTING ANY SYSTEMS THAT INCORPORATE PRODUCTS, THOROUGHLY TEST SUCH SYSTEMS FOR SAFETY PURPOSES. USE OF PRODUCTS IN A SAFETY APPLICATION WITHOUT A SAFETY DESIGN IS FULLY AT THE RISK OF CUSTOMER, SUBJECT ONLY TO APPLICABLE LAWS AND REGULATIONS GOVERNING LIMITATIONS ON PRODUCT LIABILITY.

© Copyright 2013–2019 Xilinx, Inc. Xilinx, the Xilinx logo, Artix, ISE, Kintex, Spartan, Vivado, Virtex, Zynq, and other designated brands included herein are trademarks of Xilinx in the United States and other countries. PCI, PCI Express, PCIe, and PCI-X are trademarks of PCI-SIG. All other trademarks are the property of their respective owners.

Revision History

The following table shows the revision history for this document.

Date	Version	Revision
02/04/2013	1.0	Initial Xilinx release.
06/04/2013	1.1	Changed XC7VX690T-2FFG1761CES to XC7VX690T-2FFG1761C throughout the document. Changed SiT9122 to SiT9102. The data rate in Linear BPI Flash Memory changed from 40 MHz to 80 MHz. Added items 28 and 29 to the board photograph in Figure 1-2 . FPGA EMCC clock information was added to Table 1-7 , Table 1-8 , Figure 1-13 , and FPGA EMCC Clock . In Table 1-18 , the DS1 description for RED changed. Replaced Figure 1-22 Configuration Mode and Upper Linear Flash Address Switch . Enhanced section Switches . Updated part ordering information in FMC_VADJ Voltage . Updated Figure 1-29 VC709 Board Configuration Circuit . Replaced Appendix C, Master UCF Listing with Xilinx Design Constraints . Updated References .
01/07/2014	1.2	Revised the content of Table 1-16 . Revised Table 1-20 to correct connection of FMC1_HPC_LA29_N to FPGA pin T30 (Was W30). Revised all links and references in Appendix G, Additional Resources and revised links to web pages and documents throughout document to conform to latest linking style convention. Added caution note about power connections to J18 on the VC709 board on Appendix D .
03/11/2014	1.2.1	Tech Pubs edit. Technical content not affected.

Date	Version	Revision
04/30/2014	1.3	Revised the data rate for the small outline dual-inline memory modules (SODIMMs) in VC709 Board Features and Dual DDR3 Memory SODIMMs .
12/04/2014	1.4	Added MT28GU01GAAAIEGC-0SIT part number for the BPI parallel NOR flash memory component to Table 1-1, Linear BPI Flash Memory , and References . Added a note to Table 1-1 . Updated User SMA Clock (USER_SMA_CLOCK_P and USER_SMA_CLOCK_N) , Jitter-Attenuated Clock , I2C Bus , and Power Management . Updated part number in Figure 1-4 . Updated Figure 1-11 to correct net names. Added I/O standard information to Table 1-4 , Table 1-5 , Table 1-6 , Table 1-8 , Table 1-14 , Table 1-19 , and Table 1-20 . Added PCIe® edge connector information after Table 1-12 . Updated description for XADC_GPIO_3, 2, 1, 0 in Table 1-25 . Updated Table A-3 and added Figure A-3 . Updated References .
09/02/2015	1.4.1	Made typographical edits.
03/18/2016	1.5	Updated Figure 1-16 . Added thickness information in Appendix E, Board Specifications .
08/12/2016	1.5.1	Made a typographical edit.
03/11/2019	1.6	Added the latest version of ESD Directive in Electrostatic Discharge Caution . Updated the description of Dual DDR3 Memory SODIMMs . In Appendix C, Xilinx Design Constraints changed the title of the appendix, updated the description, and removed the VC709 Board XDC Listing. Updated Appendix F, Regulatory and Compliance Information . Updated Appendix G, Additional Resources .

Table of Contents

Please Read: Important Legal Notices	2
Revision History	2

Chapter 1: VC709 Evaluation Board Features

Overview	7
Additional Information	7
VC709 Board Features	7
Electrostatic Discharge Caution	9
Feature Descriptions	10
Virtex-7 XC7VX690T-2FFG1761C FPGA	12
Dual DDR3 Memory SODIMMs	14
Linear BPI Flash Memory	22
USB JTAG	26
Clock Generation	27
Memory Clock (SYSCLK_233_P and SYSCLK_233_N)	33
FPGA EMCC Clock	34
GTH Transceivers	35
PCI Express Endpoint Connectivity	38
SFP/SFP+ Module Connectors	43
USB-to-UART Bridge	46
I2C Bus	47
Status LEDs	48
User I/O	49
Switches	52
VITA 57.1 FMC1 HPC Connector (Partially Populated)	54
Power Management	59
FMC_VADJ Voltage	62
XADC Analog-to-Digital Converter	64
Configuration Options	66

Appendix A: Default Switch and Jumper Settings

GPIO DIP Switch SW2	69
Configuration DIP Switch SW11	70
Default Jumper Settings	71

Appendix B: VITA 57.1 FMC Connector Pinouts

Appendix C: Xilinx Design Constraints

.....	75
-------	----

Appendix D: Board Setup

Installing the VC709 Board in a PC Chassis	77
---	----

Appendix E: Board Specifications

Dimensions	79
Environmental	79
Temperature	79
Humidity	79
Operating Voltage	79

Appendix F: Regulatory and Compliance Information

CE Directives	81
CE Standards	81
Electromagnetic Compatibility	81
Safety	81
Markings	82

Appendix G: Additional Resources

Xilinx Resources	83
Solution Centers	83
References	83

VC709 Evaluation Board Features

Overview

The VC709 evaluation board for the Virtex®-7 FPGA provides a hardware environment for developing and evaluating designs targeting the Virtex-7 XC7VX690T-2FFG1761C FPGA. The VC709 board provides features common to many embedded processing systems, including dual DDR3 small outline dual-inline memory module (SODIMM) memories, an 8-lane PCI Express® interface, general purpose I/O, and a UART interface. Other features can be added by using mezzanine cards attached to the VITA-57 FPGA mezzanine connector (FMC) provided on the board. A high pin count (HPC) FMC is provided. See [VC709 Board Features](#) for a complete list of features. The details for each feature are described in [Feature Descriptions](#).

Additional Information

See [Appendix G, Additional Resources](#) for references to documents, files, and resources relevant to the VC709 board.

VC709 Board Features

- Virtex-7 XC7VX690T-2FFG1761C FPGA
- 2X 4 GB 1600MTs DDR3 memory SODIMMs
- 128 MB linear byte-wide peripheral interface (BPI) flash memory
- USB JTAG through Digilent module
- Clock generation
 - Fixed 200 MHz LVDS oscillator
 - Fixed 233.33 MHz LVDS oscillator
 - I²C programmable LVDS oscillator
 - SMA connectors
 - SMA connectors for GTH transceiver clocking
- GTH transceivers
 - FMC HPC connector (ten transceivers)
 - SMA connectors (one pair for MGT_REFCLK)
 - PCI Express (eight lanes)
 - 4 X Small form-factor pluggable plus (SFP+) connectors
- PCI Express endpoint connectivity
 - Gen1 8-lane (x8)
 - Gen2 8-lane (x8)

- Gen3 8-lane (x8)
- 4 X SFP+ connectors
- USB-to-UART bridge
- I²C bus
 - I²C MUX
 - I²C EEPROM (1 KB)
 - USER I²C programmable LVDS oscillator
 - 2 X DDR3 SODIMM socket
 - FMC HPC connector
 - 4 X SFP+ connector
 - I²C programmable jitter-attenuating precision clock multiplier
- Status LEDs
 - 12VDC power on
 - TI controlled power good
 - Linear power good
 - FPGA INIT
 - FPGA DONE
- User I/O
 - User LEDs (eight GPIO)
 - User pushbuttons (five directional)
 - CPU reset pushbutton
 - User DIP switch (8-pole GPIO)
- Switches
 - Power on/off slide switch
 - FPGA_PROG_B pushbutton
 - Configuration mode DIP switch
- VITA 57.1 FMC HPC connector
- Power management
 - PMBus voltage and current monitoring through TI power controllers
- XADC header
- Configuration options
 - Linear BPI flash memory
 - USB JTAG (Digilent) configuration port

The VC709 board block diagram is shown in [Figure 1-1](#).

Electrostatic Discharge Caution

Caution! ESD can damage electronic components when they are improperly handled, and can result in total or intermittent failures. Always follow ESD-prevention procedures when removing and replacing components.

To prevent ESD damage:

- Use an ESD wrist or ankle strap and ensure that it makes skin contact. Connect the equipment end of the strap to an unpainted metal surface on the chassis.
- Avoid touching the adapter against your clothing. The wrist strap protects components from ESD on the body only.
- Handle the adapter by its bracket or edges only. Avoid touching the printed circuit board or the connectors.
- Put the adapter down only on an antistatic surface such as the bag supplied in your kit.
- If you are returning the adapter to Xilinx Product Support, place it back in its antistatic bag immediately.

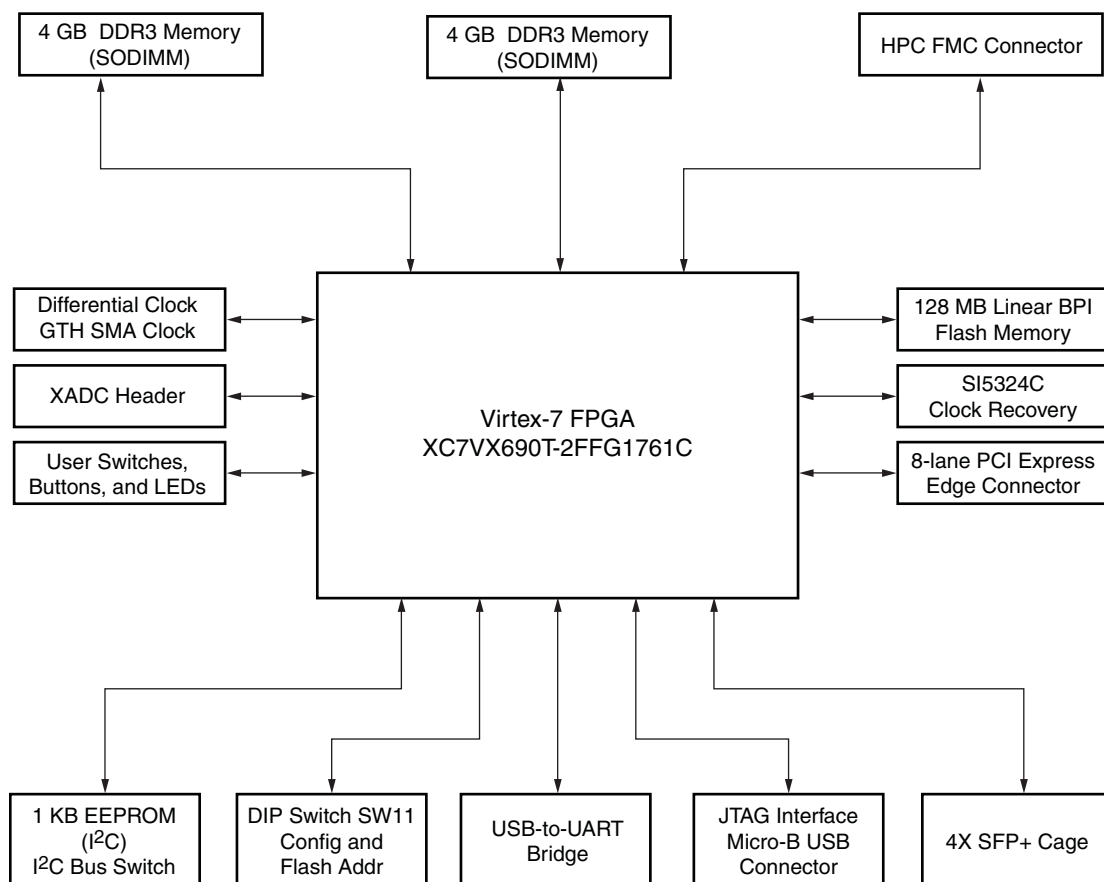

UG887_c1_01_012113

Figure 1-1: VC709 Board Block Diagram

Feature Descriptions

Figure 1-2 shows the VC709 board. Each numbered feature that is referenced in Figure 1-2 is described in Table 1-1 and following sections.

Note: The image in Figure 1-2 is for reference only and might not reflect the current revision of the board.

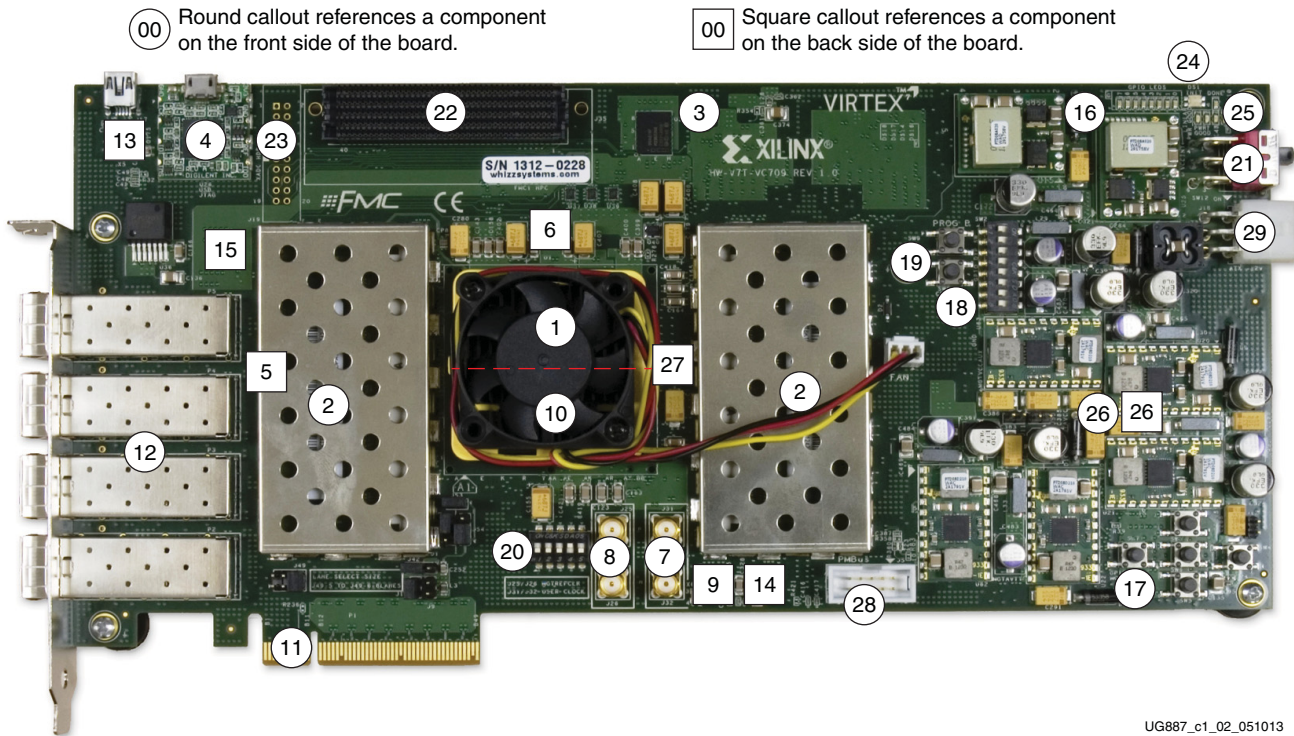

UG887_c1_02_051013

Figure 1-2: VC709 Board Component Locations

Table 1-1: VC709 Board Component Descriptions

Callout	Reference Designator	Component Description	Notes	Schematic 0381499 Page Number
1	U1	Virtex-7 FPGAXC7VX690T-2FFG1761C with cooling fan	XC7VX690T-2FFG1761C	
2	J1, J3	Two DDR3 SODIMM memories (4 GB each)	Micron MT8KTF51264HZ-1G9E1	10, 14
3	U3	BPI parallel NOR flash memory (1 Gb)	Micron PC28F00AG18FE/ MT28GU01GAAA1EGC-0SIT	24
4	U26	USB JTAG interface (micro-B USB connector)	Digilent USB JTAG module	5
5	U51	System clock, 200 MHz, LVDS (back side of board)	SiTime SIT9102-243N25E200.0000	3
6	U34	I ² C programmable user clock LVDS, 156.250 MHz default frequency (back side of board)	Silicon Labs SI570BAB0000544DG (I ² C 0x5D)	3
7	J31, J32	User SMA clock	Rosenberger 32K10K-400L5	3

Table 1-1: VC709 Board Component Descriptions (Cont'd)

Callout	Reference Designator	Component Description	Notes	Schematic 0381499 Page Number
8	J25, J26	GTH transceiver SMA reference clock	Rosenberger 32K10K-400L5	30
9	U24	Jitter-attenuated clock (back side of board)	Silicon Labs SI5324C-C-GM	4
10	U1	GTH transceiver Quad 111–Quad 119	Embedded within FPGA U1	30, 36–38
11	P1	PCI Express connector	8-lane card edge connector	35
12	P2–P5	4 X SFP/SFP+ module connector (I ² C 0x50)	Molex 74441-0010	31–35
13	U44, J17	USB-to-UART bridge with mini-B USB connector	Silicon Labs CP2103GM	6
14	U52	I ² C bus switch (I ² C 0x74) (back side of board)	TI PCA9548ARGER	29
15	U14	I ² C bus switch (I ² C 0x75) (back side of board)	TI PCA9546ARGVR	29
16	DS2–DS9	User LEDs, Green	Lumex SML-LX0603GW	25
17	SW3–SW7	User pushbuttons, active-High	E-Switch TL3301EP100QG	25
18	SW2	User DIP switch, active-High	8-pole C and K SDA08H1SBD	25
19	SW8, SW9	CPU RESET, FPGA PROG pushbuttons	E-Switch TL3301EP100QG	25, 7
20	SW11	Configuration mode/upper linear flash address DIP switch	5-pole C and K SDA05H1IBD	7
21	SW12	Power on/off slide switch	C and K 1201M2S3AQE2	46
22	J35	FMC HPC connector	Samtec ASP_134486_01	18–21
23	J19	Xilinx XADC header	2 x 10 0.1-inch male header	27
24	DS1	INIT LED, dual color Red/Green	Avago HSMF-C155	38
25	DS10, DS14, DS16–DS18	Power ON and Power GOOD LEDs	Lumex SML-LX0603GW	38
26	Various	Power management system (front and back side of board)	TI UCD9248PFC in conjunction with various regulators	45–56
27	U13	Memory clock, 233.33 MHz, LVDS (back side of board)	SiTime SIT9122AC-2D3-25E233.333333	3
28	J35	2 x 5 shrouded PMBus connector	Assman HW10G-0202	46
29	J18	12V power input 2 x 3 connector	Molex 39-30-1060	46

Notes:

1. Jumper header locations are identified in [Appendix A, Default Switch and Jumper Settings](#).

Virtex-7 XC7VX690T-2FFG1761C FPGA

[Figure 1-2, callout 1]

The VC709 board is populated with the *Virtex-7 XC7VX690T-2FFG1761C FPGA*.

For further information on Virtex-7 FPGAs, see *7 Series FPGAs Overview (DS180)* [Ref 1].

FPGA Configuration

The VC709 board supports two of the five 7 series FPGA configuration modes:

- Master BPI using the onboard linear BPI flash memory
- JTAG using a type-A to micro-B USB cable for connecting the host PC to the VC709 board configuration port

Each configuration interface corresponds to one or more configuration modes and bus widths as listed in Table 1-2. The mode switches M2, M1, and M0 are on SW11 positions 3, 4, and 5 respectively as shown in Figure 1-3.

Note: To determine the FPGA type resident on the VC709 board, see the [Virtex-7 VC709 Evaluation Kit Master Answer Record \(AR 51901\)](#).

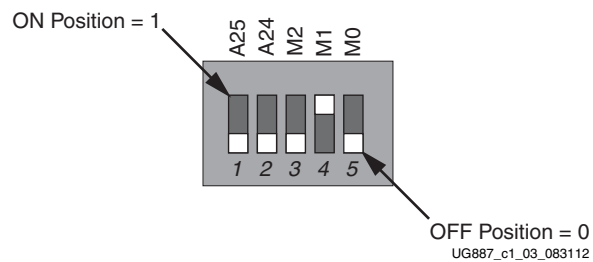

Figure 1-3: SW11 Default Settings

The default mode setting is $M[2:0] = 010$, which selects Master BPI at board power-on. See [Configuration Options](#) for detailed information about the mode switch SW11.

Table 1-2: VC709 Board FPGA Configuration Modes

Configuration Mode	SW13 DIP Switch Settings (M[2:0])	Bus Width	CCLK Direction
Master BPI	010	x8, x16	Output
JTAG	101	x1	Not applicable

For full details on configuring the FPGA, see *7 Series FPGAs Configuration User Guide (UG470)* [Ref 3].

I/O Voltage Rails

There are 17 I/O banks available on the Virtex-7 device. Fourteen I/O banks are available on the VC709 board, and banks 12, 16, and 18 are not used. The voltages applied to the FPGA I/O banks used by the VC709 board are listed in [Table 1-3](#).

Table 1-3: I/O Voltage Rails

FPGA (U1) Bank	Power Supply Rail Net Name	Voltage
Bank 0	VCC1V8_FPGA	1.8V
Bank 12	NOT USED	1.8V
Bank 13	VCC1V8_FPGA	1.8V
Bank 14	VCC1V8_FPGA	1.8V
Bank 15	VCC1V8_FPGA	1.8V
Bank 16	NOT USED	1.8V
Bank 17	VCC1V8_FPGA	1.8V
Bank 18	NOT USED	1.8V
Bank 19	VCC1V8_FPGA	1.8V
Bank 31	VCC1V5_FPGA	1.5V
Bank 32	VCC1V5_FPGA	1.5V
Bank 33	VCC1V5_FPGA	1.5V
Bank 34	VCC1V8_FPGA	1.8V
Bank 35	VADJ_FPGA	1.8V
Bank 36	FMC1_VIO_B_M2C	Variable
Bank 37	VCC1V5_FPGA	1.5V
Bank 38	VCC1V5_FPGA	1.5V
Bank 39	VCC1V5_FPGA	1.5V

Dual DDR3 Memory SODIMMs

[Figure 1-2, callout 2]

The memory modules at J1 and J3 are 4 GB DDR3 small outline dual-inline memory modules (SODIMMs), providing volatile synchronous dynamic random access memory (SDRAM) for storing user code and data.

- Part number: MT8KTF51264HZ-1G9E1 (Micron Technology)
- Supply voltage: 1.5V
- Configuration: 4GB (512 Mb x 64)
- Datapath width: 64 bits
- Data rate: Up to 1600 MT/s

The VC709 XC7VX690T FPGA memory interface performance is documented in the *Virtex-7 T and XT FPGAs Data Sheet: DC and AC Switching Characteristics* (DS183) [Ref 2].

Each DDR3 interface is implemented across three I/O banks: 37, 38, and 39 for J1 and 31, 32 and 33 for J3. Each bank is a 1.5V high-performance bank having a dedicated DCI VRP/N resistor connection. An external 0.75V reference V_{TTREF} is provided for data interface banks 37, 39, 31, and 33. Any interface connected to these banks that requires a reference voltage must use this FPGA voltage reference. The connections between the DDR3 memory SODIMM sockets and the FPGA are listed in Table 1-4 and Table 1-5.

Table 1-4: DDR3 SODIMM Socket J1 Connections to the FPGA

XCVX690T (U1) Pin	Net Name	I/O Standard	DDR3 SODIMM Memory J1	
			Pin Number	Pin Number
A20	DDR3_A_A0	SSTL15	98	A0
B19	DDR3_A_A1	SSTL15	97	A1
C20	DDR3_A_A2	SSTL15	96	A2
A19	DDR3_A_A3	SSTL15	95	A3
A17	DDR3_A_A4	SSTL15	92	A4
A16	DDR3_A_A5	SSTL15	91	A5
D20	DDR3_A_A6	SSTL15	90	A6
C18	DDR3_A_A7	SSTL15	86	A7
D17	DDR3_A_A8	SSTL15	89	A8
C19	DDR3_A_A9	SSTL15	85	A9
B21	DDR3_A_A10	SSTL15	107	A10/AP
B17	DDR3_A_A11	SSTL15	84	A11
A15	DDR3_A_A12	SSTL15	83	A12_BC_N
A21	DDR3_A_A13	SSTL15	119	A13
F17	DDR3_A_A14	SSTL15	80	A14
E17	DDR3_A_A15	SSTL15	78	A15
D21	DDR3_A_BA0	SSTL15	109	BA0

Table 1-4: DDR3 SODIMM Socket J1 Connections to the FPGA (Cont'd)

XCVX690T (U1) Pin	Net Name	I/O Standard	DDR3 SODIMM Memory J1	
			Pin Number	Pin Number
C21	DDR3_A_BA1	SSTL15	108	BA1
D18	DDR3_A_BA2	SSTL15	79	BA2
N14	DDR3_A_D0	SSTL15	5	DQ0
N13	DDR3_A_D1	SSTL15	7	DQ1
L14	DDR3_A_D2	SSTL15	15	DQ2
M14	DDR3_A_D3	SSTL15	17	DQ3
M12	DDR3_A_D4	SSTL15	4	DQ4
N15	DDR3_A_D5	SSTL15	6	DQ5
M11	DDR3_A_D6	SSTL15	16	DQ6
L12	DDR3_A_D7	SSTL15	18	DQ7
K14	DDR3_A_D8	SSTL15	21	DQ8
K13	DDR3_A_D9	SSTL15	23	DQ9
H13	DDR3_A_D10	SSTL15	33	DQ10
J13	DDR3_A_D11	SSTL15	35	DQ11
L16	DDR3_A_D12	SSTL15	22	DQ12
L15	DDR3_A_D13	SSTL15	24	DQ13
H14	DDR3_A_D14	SSTL15	34	DQ14
J15	DDR3_A_D15	SSTL15	36	DQ15
E15	DDR3_A_D16	SSTL15	39	DQ16
E13	DDR3_A_D17	SSTL15	41	DQ17
F15	DDR3_A_D18	SSTL15	51	DQ18
E14	DDR3_A_D19	SSTL15	53	DQ19
G13	DDR3_A_D20	SSTL15	40	DQ20
G12	DDR3_A_D21	SSTL15	42	DQ21
F14	DDR3_A_D22	SSTL15	50	DQ22
G14	DDR3_A_D23	SSTL15	52	DQ23
B14	DDR3_A_D24	SSTL15	57	DQ24
C13	DDR3_A_D25	SSTL15	59	DQ25
B16	DDR3_A_D26	SSTL15	67	DQ26
D15	DDR3_A_D27	SSTL15	69	DQ27
D13	DDR3_A_D28	SSTL15	56	DQ28
E12	DDR3_A_D29	SSTL15	58	DQ29

Table 1-4: DDR3 SODIMM Socket J1 Connections to the FPGA (Cont'd)

XCVX690T (U1) Pin	Net Name	I/O Standard	DDR3 SODIMM Memory J1	
			Pin Number	Pin Number
C16	DDR3_A_D30	SSTL15	68	DQ30
D16	DDR3_A_D31	SSTL15	70	DQ31
A24	DDR3_A_D32	SSTL15	129	DQ32
B23	DDR3_A_D33	SSTL15	131	DQ33
B27	DDR3_A_D34	SSTL15	141	DQ34
B26	DDR3_A_D35	SSTL15	143	DQ35
A22	DDR3_A_D36	SSTL15	130	DQ36
B22	DDR3_A_D37	SSTL15	132	DQ37
A25	DDR3_A_D38	SSTL15	140	DQ38
C24	DDR3_A_D39	SSTL15	142	DQ39
E24	DDR3_A_D40	SSTL15	147	DQ40
D23	DDR3_A_D41	SSTL15	149	DQ41
D26	DDR3_A_D42	SSTL15	157	DQ42
C25	DDR3_A_D43	SSTL15	159	DQ43
E23	DDR3_A_D44	SSTL15	146	DQ44
D22	DDR3_A_D45	SSTL15	148	DQ45
F22	DDR3_A_D46	SSTL15	158	DQ46
E22	DDR3_A_D47	SSTL15	160	DQ47
A30	DDR3_A_D48	SSTL15	163	DQ48
D27	DDR3_A_D49	SSTL15	165	DQ49
A29	DDR3_A_D50	SSTL15	175	DQ50
C28	DDR3_A_D51	SSTL15	177	DQ51
D28	DDR3_A_D52	SSTL15	164	DQ52
B31	DDR3_A_D53	SSTL15	166	DQ53
A31	DDR3_A_D54	SSTL15	174	DQ54
A32	DDR3_A_D55	SSTL15	176	DQ55
E30	DDR3_A_D56	SSTL15	181	DQ56
F29	DDR3_A_D57	SSTL15	183	DQ57
F30	DDR3_A_D58	SSTL15	191	DQ58
F27	DDR3_A_D59	SSTL15	193	DQ59
C30	DDR3_A_D60	SSTL15	180	DQ60
E29	DDR3_A_D61	SSTL15	182	DQ61

Table 1-4: DDR3 SODIMM Socket J1 Connections to the FPGA (Cont'd)

XCVX690T (U1) Pin	Net Name	I/O Standard	DDR3 SODIMM Memory J1	
			Pin Number	Pin Number
F26	DDR3_A_D62	SSTL15	192	DQ62
D30	DDR3_A_D63	SSTL15	194	DQ63
M13	DDR3_A_DM0	SSTL15	11	DM0
K15	DDR3_A_DM1	SSTL15	28	DM1
F12	DDR3_A_DM2	SSTL15	46	DM2
A14	DDR3_A_DM3	SSTL15	63	DM3
C23	DDR3_A_DM4	SSTL15	136	DM4
D25	DDR3_A_DM5	SSTL15	153	DM5
C31	DDR3_A_DM6	SSTL15	170	DM6
F31	DDR3_A_DM7	SSTL15	187	DM7
M16	DDR3_A_DQS0_N	DIFF_SSTL15	10	DQS0_N
N16	DDR3_A_DQS0_P	DIFF_SSTL15	12	DQS0_P
J12	DDR3_A_DQS1_N	DIFF_SSTL15	27	DQS1_N
K12	DDR3_A_DQS1_P	DIFF_SSTL15	29	DQS1_P
G16	DDR3_A_DQS2_N	DIFF_SSTL15	45	DQS2_N
H16	DDR3_A_DQS2_P	DIFF_SSTL15	47	DQS2_P
C14	DDR3_A_DQS3_N	DIFF_SSTL15	62	DQS3_N
C15	DDR3_A_DQS3_P	DIFF_SSTL15	64	DQS3_P
A27	DDR3_A_DQS4_N	DIFF_SSTL15	135	DQS4_N
A26	DDR3_A_DQS4_P	DIFF_SSTL15	137	DQS4_P
E25	DDR3_A_DQS5_N	DIFF_SSTL15	152	DQS5_N
F25	DDR3_A_DQS5_P	DIFF_SSTL15	154	DQS5_P
B29	DDR3_A_DQS6_N	DIFF_SSTL15	169	DQS6_N
B28	DDR3_A_DQS6_P	DIFF_SSTL15	171	DQS6_P
E28	DDR3_A_DQS7_N	DIFF_SSTL15	186	DQS7_N
E27	DDR3_A_DQS7_P	DIFF_SSTL15	188	DQS7_P
E18	DDR3_A_CLK0_N	DIFF_SSTL15	103	CK0_N
E19	DDR3_A_CLK0_P	DIFF_SSTL15	101	CK0_P
F19	DDR3_A_CLK1_N	DIFF_SSTL15	104	CK1_N
G19	DDR3_A_CLK1_P	DIFF_SSTL15	102	CK1_P
K19	DDR3_A_CKE0	SSTL15	73	CKE0
J18	DDR3_A_CKE1	SSTL15	74	CKE1

Table 1-4: DDR3 SODIMM Socket J1 Connections to the FPGA (Cont'd)

XCVX690T (U1) Pin	Net Name	I/O Standard	DDR3 SODIMM Memory J1	
			Pin Number	Pin Number
E20	DDR3_A_RAS_B	SSTL15	110	RAS_B
F20	DDR3_A_WE_B	SSTL15	113	WE_B
K17	DDR3_A_CAS_B	SSTL15	115	CAS_B
H20	DDR3_A_ODT0	SSTL15	116	ODT0
H18	DDR3_A_ODT1	SSTL15	120	ODT1
J17	DDR3_A_S0_B	SSTL15	114	S0_B
J20	DDR3_A_S1_B	SSTL15	121	S1_B
P18	DDR3_A_RESET_B	SSTL15	30	RESET_B
G17	DDR3_A_TEMP_EVENT_B	SSTL15	198	EVENT_B

Table 1-5: DDR3 SODIMM Socket J3 Connections to the FPGA

XCVX690T (U1) Pin	Net Name	I/O Standard	DDR3 SODIMM Memory J3	
			Pin Number	Pin Name
AN19	DDR3_B_A0	SSTL15	98	A0
AR19	DDR3_B_A1	SSTL15	97	A1
AP20	DDR3_B_A2	SSTL15	96	A2
AP17	DDR3_B_A3	SSTL15	95	A3
AP18	DDR3_B_A4	SSTL15	92	A4
AJ18	DDR3_B_A5	SSTL15	91	A5
AN16	DDR3_B_A6	SSTL15	90	A6
AM16	DDR3_B_A7	SSTL15	86	A7
AK18	DDR3_B_A8	SSTL15	89	A8
AK19	DDR3_B_A9	SSTL15	85	A9
AM17	DDR3_B_A10	SSTL15	107	A10/AP
AM18	DDR3_B_A11	SSTL15	84	A11
AL17	DDR3_B_A12	SSTL15	83	A12_BC_N
AK17	DDR3_B_A13	SSTL15	119	A13
AM19	DDR3_B_A14	SSTL15	80	A14
AL19	DDR3_B_A15	SSTL15	78	A15
AR17	DDR3_B_BA0	SSTL15	109	BA0
AR18	DDR3_B_BA1	SSTL15	108	BA1
AN18	DDR3_B_BA2	SSTL15	79	BA2

Table 1-5: DDR3 SODIMM Socket J3 Connections to the FPGA (Cont'd)

XCVX690T (U1) Pin	Net Name	I/O Standard	DDR3 SODIMM Memory J3	
			Pin Number	Pin Name
AN24	DDR3_B_D0	SSTL15	5	DQ0
AM24	DDR3_B_D1	SSTL15	7	DQ1
AR22	DDR3_B_D2	SSTL15	15	DQ2
AR23	DDR3_B_D3	SSTL15	17	DQ3
AN23	DDR3_B_D4	SSTL15	4	DQ4
AM23	DDR3_B_D5	SSTL15	6	DQ5
AN21	DDR3_B_D6	SSTL15	16	DQ6
AP21	DDR3_B_D7	SSTL15	18	DQ7
AK23	DDR3_B_D8	SSTL15	21	DQ8
AJ23	DDR3_B_D9	SSTL15	23	DQ9
AL21	DDR3_B_D10	SSTL15	33	DQ10
AM21	DDR3_B_D11	SSTL15	35	DQ11
AJ21	DDR3_B_D12	SSTL15	22	DQ12
AJ20	DDR3_B_D13	SSTL15	24	DQ13
AK20	DDR3_B_D14	SSTL15	34	DQ14
AL20	DDR3_B_D15	SSTL15	36	DQ15
AW22	DDR3_B_D16	SSTL15	39	DQ16
AW23	DDR3_B_D17	SSTL15	41	DQ17
AW21	DDR3_B_D18	SSTL15	51	DQ18
AV21	DDR3_B_D19	SSTL15	53	DQ19
AU23	DDR3_B_D20	SSTL15	40	DQ20
AV23	DDR3_B_D21	SSTL15	42	DQ21
AR24	DDR3_B_D22	SSTL15	50	DQ22
AT24	DDR3_B_D23	SSTL15	52	DQ23
BB24	DDR3_B_D24	SSTL15	57	DQ24
BA24	DDR3_B_D25	SSTL15	59	DQ25
AY23	DDR3_B_D26	SSTL15	67	DQ26
AY24	DDR3_B_D27	SSTL15	69	DQ27
AY25	DDR3_B_D28	SSTL15	56	DQ28
BA25	DDR3_B_D29	SSTL15	58	DQ29
BB21	DDR3_B_D30	SSTL15	68	DQ30
BA21	DDR3_B_D31	SSTL15	70	DQ31

Table 1-5: DDR3 SODIMM Socket J3 Connections to the FPGA (Cont'd)

XCVX690T (U1) Pin	Net Name	I/O Standard	DDR3 SODIMM Memory J3	
			Pin Number	Pin Name
AY14	DDR3_B_D32	SSTL15	129	DQ32
AW15	DDR3_B_D33	SSTL15	131	DQ33
BB14	DDR3_B_D34	SSTL15	141	DQ34
BB13	DDR3_B_D35	SSTL15	143	DQ35
AW12	DDR3_B_D36	SSTL15	130	DQ36
AY13	DDR3_B_D37	SSTL15	132	DQ37
AY12	DDR3_B_D38	SSTL15	140	DQ38
BA12	DDR3_B_D39	SSTL15	142	DQ39
AU12	DDR3_B_D40	SSTL15	147	DQ40
AU13	DDR3_B_D41	SSTL15	149	DQ41
AT12	DDR3_B_D42	SSTL15	157	DQ42
AU14	DDR3_B_D43	SSTL15	159	DQ43
AV13	DDR3_B_D44	SSTL15	146	DQ44
AW13	DDR3_B_D45	SSTL15	148	DQ45
AT15	DDR3_B_D46	SSTL15	158	DQ46
AR15	DDR3_B_D47	SSTL15	160	DQ47
AL15	DDR3_B_D48	SSTL15	163	DQ48
AJ15	DDR3_B_D49	SSTL15	165	DQ49
AK14	DDR3_B_D50	SSTL15	175	DQ50
AJ12	DDR3_B_D51	SSTL15	177	DQ51
AJ16	DDR3_B_D52	SSTL15	164	DQ52
AL16	DDR3_B_D53	SSTL15	166	DQ53
AJ13	DDR3_B_D54	SSTL15	174	DQ54
AK13	DDR3_B_D55	SSTL15	176	DQ55
AR14	DDR3_B_D56	SSTL15	181	DQ56
AT14	DDR3_B_D57	SSTL15	183	DQ57
AM12	DDR3_B_D58	SSTL15	191	DQ58
AP11	DDR3_B_D59	SSTL15	193	DQ59
AM13	DDR3_B_D60	SSTL15	180	DQ60
AN13	DDR3_B_D61	SSTL15	182	DQ61
AM11	DDR3_B_D62	SSTL15	192	DQ62
AN11	DDR3_B_D63	SSTL15	194	DQ63

Table 1-5: DDR3 SODIMM Socket J3 Connections to the FPGA (Cont'd)

XCVX690T (U1) Pin	Net Name	I/O Standard	DDR3 SODIMM Memory J3	
			Pin Number	Pin Name
AT22	DDR3_B_DM0	SSTL15	11	DM0
AL22	DDR3_B_DM1	SSTL15	28	DM1
AU24	DDR3_B_DM2	SSTL15	46	DM2
BB23	DDR3_B_DM3	SSTL15	63	DM3
BB12	DDR3_B_DM4	SSTL15	136	DM4
AV15	DDR3_B_DM5	SSTL15	153	DM5
AK12	DDR3_B_DM6	SSTL15	170	DM6
AP13	DDR3_B_DM7	SSTL15	187	DM7
AP22	DDR3_B_DQS0_N	DIFF_SSTL15	10	DQS0_N
AP23	DDR3_B_DQS0_P	DIFF_SSTL15	12	DQS0_P
AK22	DDR3_B_DQS1_N	DIFF_SSTL15	27	DQS1_N
AJ22	DDR3_B_DQS1_P	DIFF_SSTL15	29	DQS1_P
AU21	DDR3_B_DQS2_N	DIFF_SSTL15	45	DQS2_N
AT21	DDR3_B_DQS2_P	DIFF_SSTL15	47	DQS2_P
BB22	DDR3_B_DQS3_N	DIFF_SSTL15	62	DQS3_N
BA22	DDR3_B_DQS3_P	DIFF_SSTL15	64	DQS3_P
BA14	DDR3_B_DQS4_N	DIFF_SSTL15	135	DQS4_N
BA15	DDR3_B_DQS4_P	DIFF_SSTL15	137	DQS4_P
AR12	DDR3_B_DQS5_N	DIFF_SSTL15	152	DQS5_N
AP12	DDR3_B_DQS5_P	DIFF_SSTL15	154	DQS5_P
AL14	DDR3_B_DQS6_N	DIFF_SSTL15	169	DQS6_N
AK15	DDR3_B_DQS6_P	DIFF_SSTL15	171	DQS6_P
AN14	DDR3_B_DQS7_N	DIFF_SSTL15	186	DQS7_N
AN15	DDR3_B_DQS7_P	DIFF_SSTL15	188	DQS7_P
AU17	DDR3_B_CLK0_N	DIFF_SSTL15	101	CK0_P
AT17	DDR3_B_CLK0_P	DIFF_SSTL15	103	CK0_N
AV18	DDR3_B_CLK1_N	DIFF_SSTL15	102	CK1_P
AU18	DDR3_B_CLK1_P	DIFF_SSTL15	104	CK1_N
AW17	DDR3_B_CKE0	SSTL15	73	CKE0
AW18	DDR3_B_CKE1	SSTL15	74	CKE1
AV19	DDR3_B_RAS_B	SSTL15	110	RAS_B
AU19	DDR3_B_WE_B	SSTL15	113	WE_B

Table 1-5: DDR3 SODIMM Socket J3 Connections to the FPGA (Cont'd)

XCVX690T (U1) Pin	Net Name	I/O Standard	DDR3 SODIMM Memory J3	
			Pin Number	Pin Name
AT20	DDR3_B_CAS_B	SSTL15	115	CAS_B
AT16	DDR3_B_ODT0	SSTL15	116	ODT0
AW16	DDR3_B_ODT1	SSTL15	120	ODT1
AV16	DDR3_B_S0_B	SSTL15	114	S0_B
AT19	DDR3_B_S1_B	SSTL15	121	S1_B
BB19	DDR3_B_RESET_B	SSTL15	30	RESET_B
AU16	DDR3_B_TEMP_EVENT_B	SSTL15	198	EVENT_B

The VC709 DDR3 SODIMM interfaces adhere to the constraints guidelines documented in the DDR3 Design Guidelines section of *7 Series FPGAs Memory Interface Solutions User Guide* (UG586) [Ref 4]. The VC709 DDR3 SODIMM interfaces are 40Ω impedance implementations. Other memory interface details are also available in *7 Series FPGAs Memory Interface Solutions User Guide* (UG586) [Ref 4] and *7 Series FPGAs Memory Resources User Guide* (UG473) [Ref 5].

Linear BPI Flash Memory

[Figure 1-2, callout 3]

The linear BPI flash memory located at U3 provides 128 MB of nonvolatile storage that can be used for configuration or software storage. The data, address, and control signals are connected to the FPGA. The BPI flash memory device is packaged in a 64-pin BGA.

- Part number: PC28F00AG18FE/MT28GU01GAAA1EGC-0SIT
Note: MT28GU01GAAA1EGC-0SIT is a new Micron part, and either part might be installed on the VC709 board.
- Supply voltage: 1.8V
- Datapath width: 16 bits (26 address lines and 7 control signals)
- Data rate: Up to 80 MHz

The linear BPI flash memory can synchronously configure the FPGA in Master BPI mode at the 80 MHz data rate supported by the flash memory by using a configuration bitstream generated with BitGen options for synchronous configuration. The fastest configuration method uses the external 80 MHz oscillator connected to the FPGA EMCCLK pin.

Multiple bitstreams can be stored in the linear BPI flash. The two most significant address bits (A25, A24) of the flash memory are connected to DIP switch SW11 positions 1 and 2 respectively, and to the RS1 and RS0 pins of the FPGA. By placing valid XC7VX690T bitstreams at four different offset addresses in the flash memory, 1 of the 4 bitstreams can be selected to configure the FPGA by appropriately setting the DIP switch SW11. The connections between the BPI flash memory and the FPGA are listed in [Table 1-6](#).

Table 1-6: BPI Flash Memory Connections to the FPGA

FPGA (U1) Pin	Net Name	I/O Standard	BPI Flash Memory (U3)	
			Pin Number	Pin Name
AJ28	FLASH_A0	LVC MOS18	A1	A1
AH28	FLASH_A1	LVC MOS18	B1	A2
AG31	FLASH_A2	LVC MOS18	C1	A3
AF30	FLASH_A3	LVC MOS18	D1	A4
AK29	FLASH_A4	LVC MOS18	D2	A5
AK28	FLASH_A5	LVC MOS18	A2	A6
AG29	FLASH_A6	LVC MOS18	C2	A7
AK30	FLASH_A7	LVC MOS18	A3	A8
AJ30	FLASH_A8	LVC MOS18	B3	A9
AH30	FLASH_A9	LVC MOS18	C3	A10
AH29	FLASH_A10	LVC MOS18	D3	A11
AL30	FLASH_A11	LVC MOS18	C4	A12
AL29	FLASH_A12	LVC MOS18	A5	A13
AN33	FLASH_A13	LVC MOS18	B5	A14
AM33	FLASH_A14	LVC MOS18	C5	A15
AM32	FLASH_A15	LVC MOS18	D7	A16
AV41	FLASH_A16	LVC MOS18	D8	A17
AU41	FLASH_A17	LVC MOS18	A7	A18
BA42	FLASH_A18	LVC MOS18	B7	A19
AU42	FLASH_A19	LVC MOS18	C7	A20
AT41	FLASH_A20	LVC MOS18	C8	A21
BA40	FLASH_A21	LVC MOS18	A8	A22
BA39	FLASH_A22	LVC MOS18	G1	A23
BB39	FLASH_A23	LVC MOS18	H8	A24
AW42	FLASH_A24	LVC MOS18	B6	A25
AW41	FLASH_A25	LVC MOS18	B8	A26
NA	NC	NA	H1	A27
AM36	FLASH_D0	LVC MOS18	F2	DQ0

Table 1-6: BPI Flash Memory Connections to the FPGA (Cont'd)

FPGA (U1) Pin	Net Name	I/O Standard	BPI Flash Memory (U3)	
			Pin Number	Pin Name
AN36	FLASH_D1	LVC MOS18	E2	DQ1
AJ36	FLASH_D2	LVC MOS18	G3	DQ2
AJ37	FLASH_D3	LVC MOS18	E4	DQ3
AK37	FLASH_D4	LVC MOS18	E5	DQ4
AL37	FLASH_D5	LVC MOS18	G5	DQ5
AN35	FLASH_D6	LVC MOS18	G6	DQ6
AP35	FLASH_D7	LVC MOS18	H7	DQ7
AM37	FLASH_D8	LVC MOS18	E1	DQ8
AG33	FLASH_D9	LVC MOS18	E3	DQ9
AH33	FLASH_D10	LVC MOS18	F3	DQ10
AK35	FLASH_D11	LVC MOS18	F4	DQ11
AL35	FLASH_D12	LVC MOS18	F5	DQ12
AJ31	FLASH_D13	LVC MOS18	H5	DQ13
AH34	FLASH_D14	LVC MOS18	G7	DQ14
AJ35	FLASH_D15	LVC MOS18	E7	DQ15
AM34	FLASH_WAIT	LVC MOS18	F7	WAIT
BB41	FPGA_FWE_B	LVC MOS18	G8	WE_B
BA41	FLASH_OE_B	LVC MOS18	F8	OE_B
N10	FPGA_CCLK	LVC MOS18	E6	CLK
AL36	FLASH_CE_B	LVC MOS18	B4	CE_B
AY37	FLASH_ADV_B	LVC MOS18	F6	ADV_B
AG11	FPGA_INIT_B	LVC MOS18	D4	RST_B

Additional FPGA bitstreams can be stored and used for configuration by setting the Warm Boot Start Address (WBSTAR) register contained in 7 series FPGAs. More information is available in the reconfiguration and multiboot section in *7 Series FPGAs Configuration User Guide (UG470)* [Ref 3].

The configuration section of *7 Series FPGAs Configuration User Guide (UG470)* [Ref 3] provides details on the Master BPI configuration mode.

Figure 1-4 shows the linear BPI flash memory on the VC709 board. For more details, see the Micron Technology, Inc MT28GU01GAAA1EGC data sheet[Ref 13].

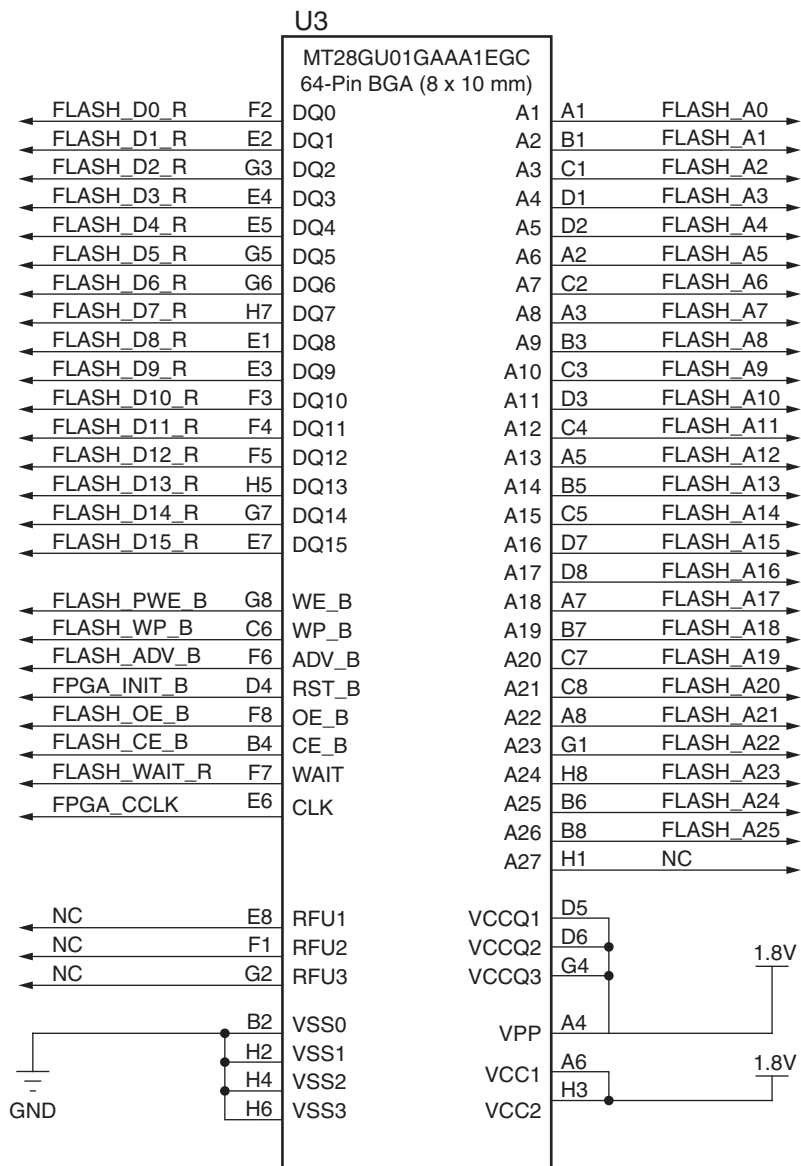

UG887_c1_04_101514

Figure 1-4: 128 MB Linear Flash Memory (U3)

USB JTAG

[Figure 1-2, callout 4]

JTAG configuration is provided solely through a Digilent onboard USB-to-JTAG configuration logic module (U26) where a host computer accesses the VC709 board JTAG chain through a type-A (host side) to micro-B (VC709 board side) USB cable.

The JTAG chain of the VC709 board is illustrated in Figure 1-5. JTAG configuration is allowed at any time regardless of FPGA mode pin settings. JTAG initiated configuration takes priority over the configuration method selected through the FPGA mode pin settings at SW11.

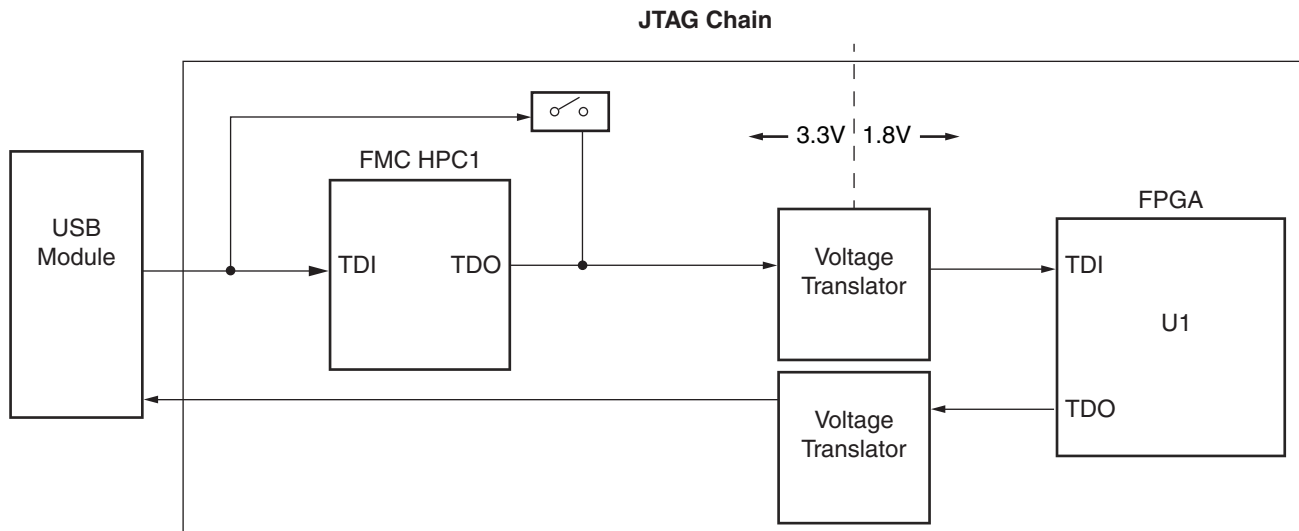

UG887_c1_05_100912

Figure 1-5: JTAG Chain Block Diagram

When an FMC mezzanine card is attached to the VC709 HPC connector J35, it is automatically added to the JTAG chain through electronically controlled single-pole single-throw (SPST) switch U27. The SPST switch is in a normally closed state and transitions to an open state when an FMC mezzanine card is attached. Switch U27 adds an attached FMC mezzanine card to the FPGAs JTAG chain as determined by the FMC_HPC_PRSNT_M2C_B signal. The attached FMC card must implement a TDI-to-TDO connection through a device or bypass jumper for the JTAG chain to be completed to the FPGA U1.

The JTAG connectivity on the VC709 board allows a host computer to download bitstreams to the FPGA using the Xilinx tools. In addition, the JTAG connector allows debug tools or a software debugger to access the FPGA. The Xilinx tools can also indirectly program the linear BPI flash memory. To accomplish this, the Xilinx tools configure the FPGA with a temporary design to access and program the BPI memory device.

The JTAG circuit details are shown in Figure 1-6.

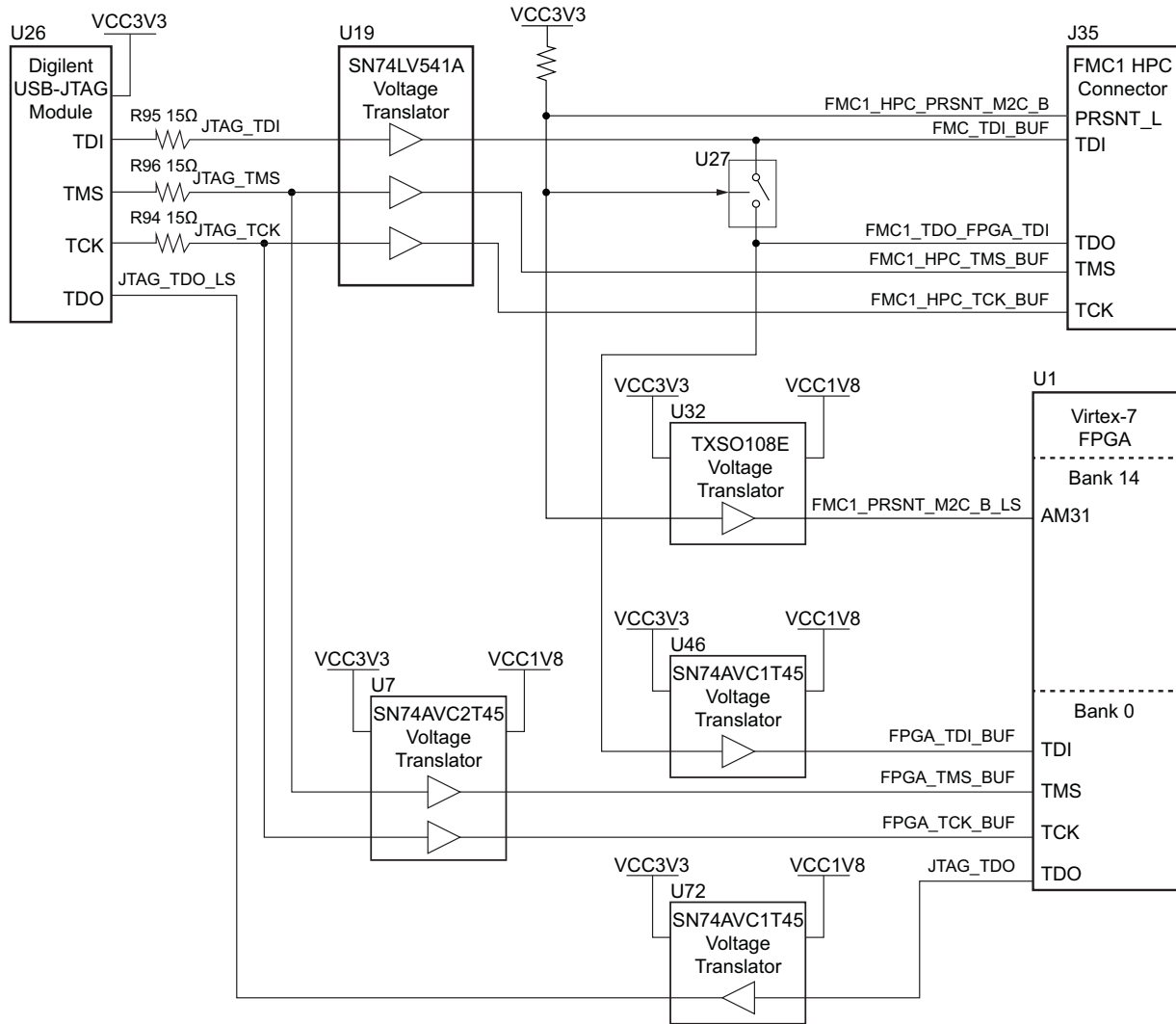

UG855_c1_06_101714

Figure 1-6: JTAG Circuit

Clock Generation

The VC709 board provides six clock sources for the FPGA. Table 1-7 lists the source devices for each clock.

Table 1-7: VC709 Board Clock Sources

Clock Name	Clock Source	Description
System clock	U51	SiT9102 2.5V LVDS 200 MHz fixed frequency oscillator (Si Time) See System Clock (SYSCLK_P and SYSCLK_N) .
User clock	U34	Si570 3.3V LVDS I ² C Programmable Oscillator, (I ² C address 0x5D), 156.250 MHz default (Silicon Labs). See Programmable User Clock (USER_CLOCK_P and USER_CLOCK_N) .
User SMA clock (differential pair)	J31	USER_SMA_CLOCK_P (net name) See User SMA Clock (USER_SMA_CLOCK_P and USER_SMA_CLOCK_N) .
	J32	USER_SMA_CLOCK_N (net name) See User SMA Clock (USER_SMA_CLOCK_P and USER_SMA_CLOCK_N) .
GTH SMA REF clock (differential pair)	J25	SMA_MGT_REFCLK_C_P (net name) See GTH SMA Clock (SMA_MGT_REFCLK_P and SMA_MGT_REFCLK_N) .
	J26	SMA_MGT_REFCLK_C_N (net name) See GTH SMA Clock (SMA_MGT_REFCLK_P and SMA_MGT_REFCLK_N) .
Jitter-attenuated clock	U24	Si5324C LVDS precision clock multiplier/jitter attenuator (Silicon Labs) See Jitter-Attenuated Clock .
Memory clock	U13	SiT9122 2.5V LVDS 233.33 MHz fixed frequency oscillator (Si Time). See Memory Clock (SYSCLK_233_P and SYSCLK_233_N) .
FPGA EMCC clock	U40	SiT8103 LVCMOS single-ended, 80 MHz, fixed-frequency oscillator (Si Time). See FPGA EMCC Clock .

Table 1-8 lists the pin-to-pin connections from each clock source to the FPGA.

Table 1-8: Clock Connections, Source to FPGA

Clock Source Pin	Net Name	I/O Standard	XCVX690T (U1) Pin
U51.5	SYSClk_N	DIFF_SSTL15	G18
U51.4	SYSClk_P	DIFF_SSTL15	H19
U34.5	USER_CLOCK_N	LVDS	AL34
U34.4	USER_CLOCK_P	LVDS	AK34
J26.1	SMA_MGT_REFCLK_N	NA	AK7
J25.1	SMA_MGT_REFCLK_P	NA	AK8
J32.1	USER_SMA_CLOCK_N	LVDS	AK32
J31.1	USER_SMA_CLOCK_P	LVDS	AJ32
U24.29	Si5324_OUT_N	LVDS	AH7
U24.28	Si5324_OUT_P	LVDS	AH8
U13.5	SYSClk_233_N	DIFF_SSTL15	AY17
U13.4	SYSClk_233_P	DIFF_SSTL15	AY18
U40.3	FPGA_EMCClk	LVC MOS18	AP37

System Clock (SYSClk_P and SYSClk_N)

[Figure 1-2, callout 5]

The VC709 board has an LVDS 200 MHz oscillator (U51) soldered onto the back side of the board and wired to an FPGA MRCC clock input on bank 38. This 200 MHz signal pair is named SYSClk_P and SYSClk_N, which are connected to FPGA U1 pins H19 and G18 respectively.

- Oscillator: Si Time SiT9102AI-243N25E200.00000 (200 MHz)
- PPM frequency jitter: 50 ppm
- Differential output

The LVDS termination resistor R2, located within the FPGA via matrix on the bottom of the board, is not populated. One possible I/O standard for the FPGA design clock input is:

```
NET "sysclk_p" LOC = "H19" | IOSTANDARD = DIFF_SSTL15_DCI | #Bank 38
MRCC input
NET "sysclk_n" LOC = "G18" | IOSTANDARD = DIFF_SSTL15_DCI | #Diff.
Rterm R2 DNP
```

For more details, see the [Si Time](#) SiT9102 data sheet. The system clock circuit is shown in Figure 1-7.

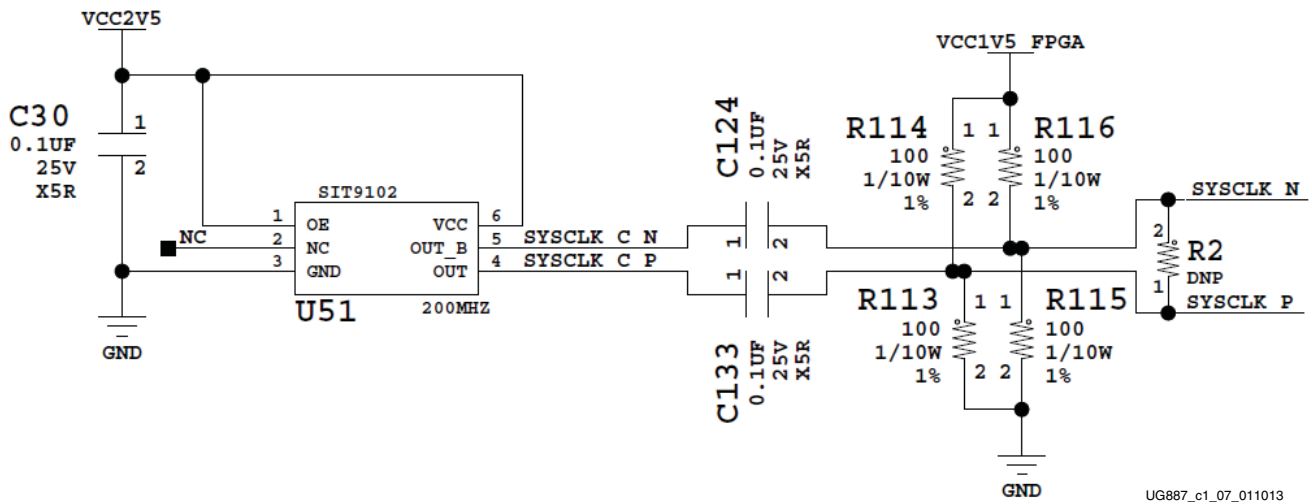

Figure 1-7: System Clock Source

Programmable User Clock (USER_CLOCK_P and USER_CLOCK_N)

[Figure 1-2, callout 6]

The VC709 board has a programmable low-jitter 3.3V differential oscillator (U34) connected to the FPGA MRCC inputs of bank 14. This USER_CLOCK_P and USER_CLOCK_N clock signal pair are connected to FPGA U1 pins AK34 and AL34 respectively. On power-up, the user clock defaults to an output frequency of 156.250 MHz. User applications can change the output frequency within the range of 10 MHz to 810 MHz through an I²C interface. Power cycling the VC709 board reverts the user clock to its default frequency of 156.250 MHz.

- Programmable oscillator: Silicon Labs Si570BAB0000544DG (10 MHz – 810 MHz)
- PPM frequency jitter: 50 ppm
- Differential output
- I²C address 0x5D

For more details, see the [Silicon Labs Si570 data sheet](#). The user clock circuit is shown in [Figure 1-8](#).

Note: In [Figure 1-8](#), USER_CLOCK_N and USER_CLOCK_P are differential clock signals.

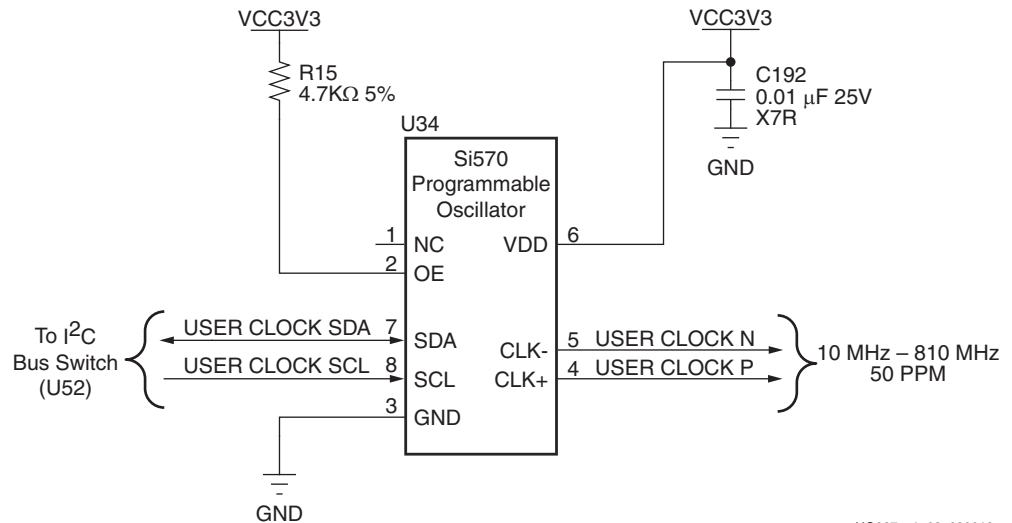

Figure 1-8: User Clock Source

User SMA Clock (USER_SMA_CLOCK_P and USER_SMA_CLOCK_N)

[[Figure 1-2](#), callout 7]

An external high-precision clock signal can be provided to the FPGA bank 14 by connecting differential clock signals through the onboard 50Ω SMA connectors J31 (P) and J32 (N). The differential clock signal names are USER_SMA_CLOCK_P and USER_SMA_CLOCK_N, which are connected to FPGA U1 pins AJ32 and AK32 respectively. These clock connections are connected directly to the FPGA U1 pins (no series capacitors and no external parallel termination resistor). The user-provided 1.8V differential clock circuit is shown in [Figure 1-9](#).

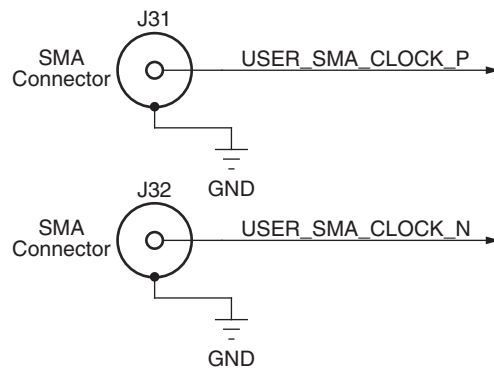

Figure 1-9: User SMA Clock Source

GTH SMA Clock (SMA_MGT_REFCLK_P and SMA_MGT_REFCLK_N)

[Figure 1-2, callout 8]

The VC709 board includes a pair of SMA connectors for a GTH clock wired to GTH Quad bank 113. This differential clock has signal names SMA_MGT_REFCLK_P and SMA_MGT_REFCLK_N, which are connected to FPGA U1 pins AK8 and AK7 respectively. Figure 1-10 shows this AC-coupled clock circuit.

- External user-provided GTH reference clock on SMA input connectors
- 1.8V differential input

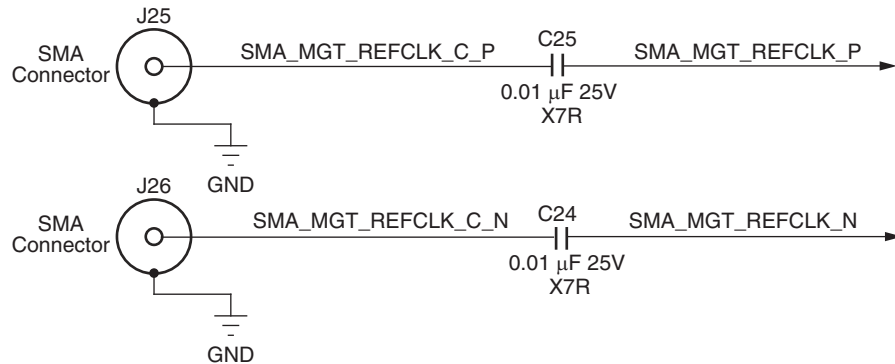

UG887_c1_10_090612

Figure 1-10: GTH SMA Clock Source

Jitter-Attenuated Clock

[Figure 1-2, callout 9]

The VC709 board includes a Silicon Labs Si5324 jitter attenuator U24 on the back side of the board. FPGA user logic can implement a clock recovery circuit and then output this clock to a differential I/O pair on I/O bank 13 (REC_CLOCK_C_P, FPGA U1 pin AW32 and REC_CLOCK_C_N, FPGA U1 pin AW33) for jitter attenuation. The jitter-attenuated clock (Si5324_OUT_C_P, Si5324_OUT_C_N) is then routed as a reference clock to GTH Quad 113 inputs MGTREFCLK0P (FPGA U1 pin AH8) and MGTREFCLK0N (FPGA U1 pin AH7). The Si5324 U24 jitter attenuator has two LVC MOS18 connections to the XCVX690T FPGA U1.

The Silicon Labs Si5324 U24 pin 1 reset net SI5324_RST must be driven High to enable the device. U24 pin 3 net SI5324_INT_ALM is level-shifted to 1.8V by U47 and is connected to U1 bank 13 pin AU34. U24 pin 1 net SI5324_RST is level-shifted to 1.8V by U39 and is connected to U1 bank 13 pin AT36. An active-Low input performs an external hardware reset of device. This resets all internal logic to a known state and forces the device registers to their default value. The clock outputs are disabled during reset. The part must be programmed after a reset or power-on to get a clock output. The reset pin 1 has a weak internal pull-up.

The primary purpose of this clock is to support CPRI/OBSAI applications that perform clock recovery from a user-supplied SFP/SFP+ module and use the jitter-attenuated recovered clock to drive the reference clock inputs of a GTH transceiver. The jitter-attenuated clock circuit is shown in Figure 1-11.

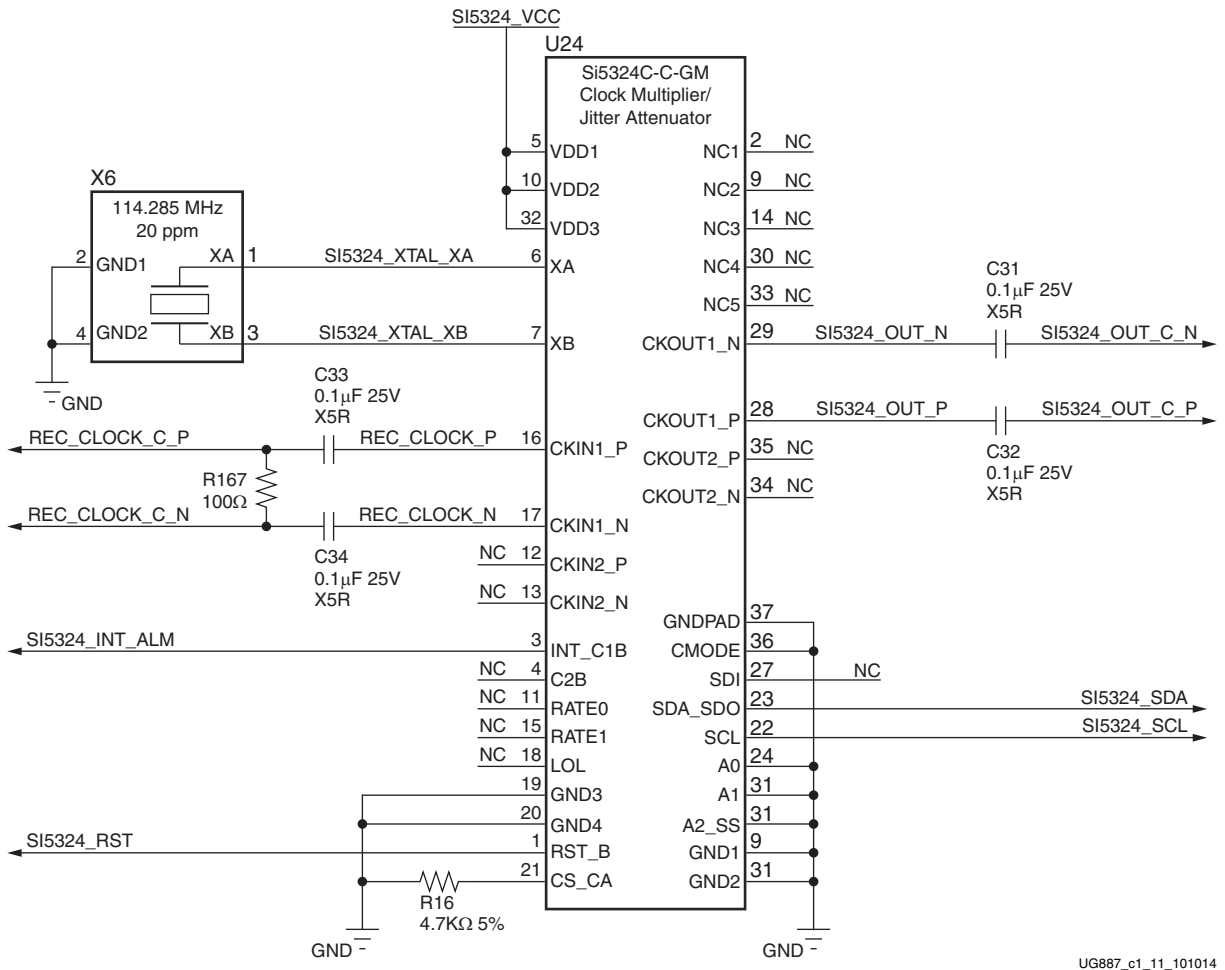

Figure 1-11: Jitter-Attenuated Clock

1. See the [Silicon Labs](#) Si5324 data sheet for more information on this device.

Memory Clock (SYSCLK_233_P and SYSCLK_233_N)

[Figure 1-2, callout 27]

The VC709 board has a LVDS 233.3333 MHz oscillator (U13) soldered onto the back side of the board and wired to an FPGA MRCC clock input on bank 32. This 233.3333 MHz signal pair is named SYSCLK_233_P and SYSCLK_233_N. The P and N signals are connected to FPGA U1 pins AY18 and AY17 respectively.

- Oscillator: Si Time SIT9122AC-2D3-25E233.333333 (233.3333 MHz)
- PPM frequency jitter: 50 ppm
- Differential output

The LVDS termination resistor R43 is located within the FPGA via matrix on the bottom of the board, and is not populated.

One possible I/O standard for the FPGA design clock input is:

```
NET "sysclk_233_p" LOC = "AY18" | IOSTANDARD = DIFF_SSTL15_DCI | #Bank
32 MRCC input
NET "sysclk_233_n" LOC = "AY17" | IOSTANDARD = DIFF_SSTL15_DCI | #Diff.
Rterm R43 DNP
```

- For more details, see the [Si Time](#) SiT9122 data sheet. The system clock circuit is shown in [Figure 1-12](#).

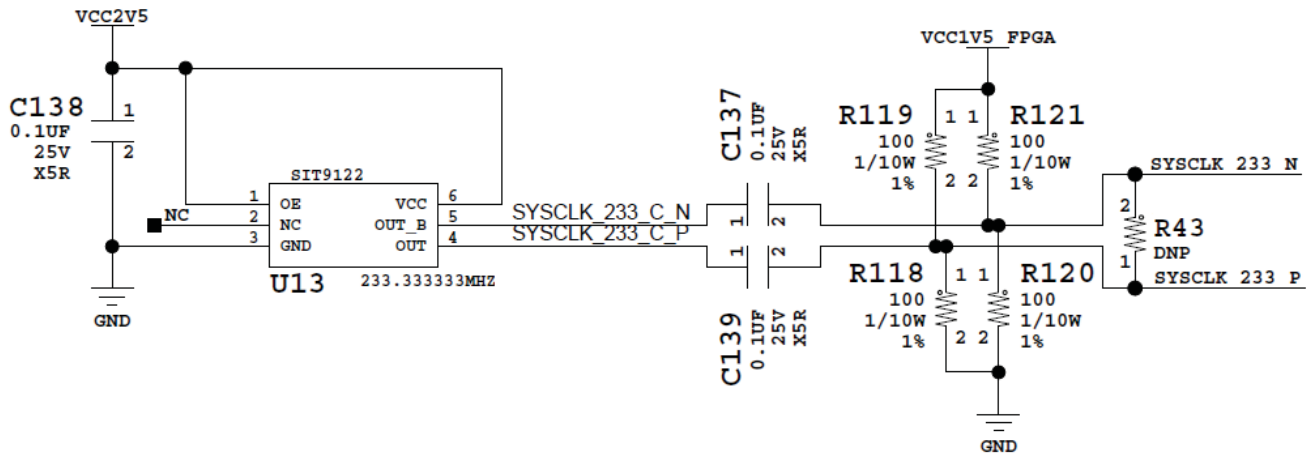

UG887_c1_12_011013

Figure 1-12: Memory Clock Source

FPGA EMCC Clock

Note: There is no [Figure 1-2](#) callout for this clock. It is located on the top side of the board near the upper left edge of SODIMM socket J3.

The VC709 board has a LVCMOS 80 MHz oscillator (U40) soldered onto the board and wired to the FPGA EMCCLK clock input pin AP37 on bank 14. This 80 MHz single-ended signal is named FPGA_EMCCLK.

- Oscillator: Si Time SIT8103AC-23-18E-80.0000Y
- PPM frequency jitter: 50 ppm
- Single-ended 1.8V LVCMOS output

The FPGA EMCC external configuration clock circuit is shown in [Figure 1-13](#).

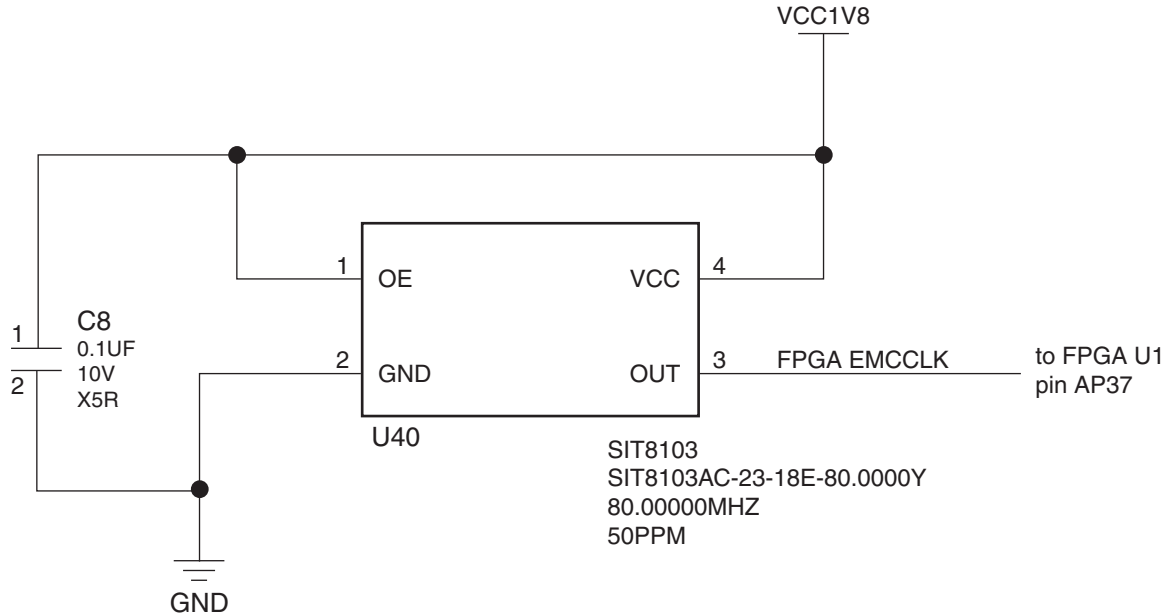

Figure 1-13: FPGA External EMCC Clock

GTH Transceivers

[[Figure 1-2](#), callout 10]

The VC709 board provides access to 22 GTH transceivers:

- Eight of the GTH transceivers are wired to the PCI Express x8 endpoint edge connector (P1) fingers.
- Ten of the GTH transceivers are wired to the FMC HPC connector (J35).
- Four of the GTH transceivers are wired to the four SFP/SFP+ connectors (P2, P3, P4, P5).

The GTH transceivers in 7 series FPGAs are grouped into four channels described as Quads. The reference clock for a Quad can be sourced from the Quad above or Quad below the GTH Quad of interest. There are six GTH Quads on the VC709 board with connectivity as shown here:

- Quad 113:
 - MGTREFCLK0 - Si5324 jitter attenuator
 - MGTREFCLK1 - SMA clock
 - Contains 4 GTH transceivers with one each allocated to SFP 1 through 4
- Quad 114:
 - MGTREFCLK0 - No clock
 - MGTREFCLK1 - No clock
 - Contains 4 GTH transceivers for PCIe lanes 4–7
- Quad 115:
 - MGTREFCLK0 - No clock
 - MGTREFCLK1 - PCIe edge connector clock

- Contains 4 GTH transceivers for PCIe lanes 0–3
- Quad 117:
 - MGTREFCLK0 - No clock
 - MGTREFCLK1 - No clock
 - Contains 2 GTH transceivers for FMC1 HPC (DP8–DP9)
- Quad 118:
 - MGTREFCLK0 - FMC1 HPC GBTCLK1
 - MGTREFCLK1 - FMC1 HPC GBTCLK0
 - Contains 4 GTH transceivers for FMC1 HPC (DP4–DP7)
- Quad 119:
 - MGTREFCLK0 - No clock
 - MGTREFCLK1 - No clock
 - Contains 4 GTH transceivers for FMC1 HPC (DP0–DP3)

Table 1-19 lists the GTH quad channel and clock connection assignments.

Table 1-9: GTH Quad Connection Assignments

Transceiver Bank	Channel/Clock	Connections
MGT_BANK_113	GTHE2_CHANNEL_X1Y15	SFP/SFP+ 4
	GTHE2_CHANNEL_X1Y14	SFP/SFP+ 3
	GTHE2_CHANNEL_X1Y13	SFP/SFP+ 2
	GTHE2_CHANNEL_X1Y12	SFP/SFP+ 1
	MGTREFCLK0	Si5324 jitter attenuator
	MGTREFCLK1	SMA_MGT_REFCLK
MGT_BANK_114	GTHE2_CHANNEL_X1Y19	PCIe4
	GTHE2_CHANNEL_X1Y18	PCIe5
	GTHE2_CHANNEL_X1Y17	PCIe6
	GTHE2_CHANNEL_X1Y16	PCIe7
	MGTREFCLK0	NC
	MGTREFCLK1	NC
MGT_BANK_115	GTHE2_CHANNEL_X1Y23	PCIe0
	GTHE2_CHANNEL_X1Y22	PCIe1
	GTHE2_CHANNEL_X1Y21	PCIe2
	GTHE2_CHANNEL_X1Y20	PCIe3
	MGTREFCLK0	NC
	MGTREFCLK1	PCIe_CLK
MGT_BANK_117	GTHE2_CHANNEL_X1Y31	NC
	GTHE2_CHANNEL_X1Y30	NC

Table 1-9: GTH Quad Connection Assignments (Cont'd)

Transceiver Bank	Channel/Clock	Connections
	GTHE2_CHANNEL_X1Y29	FMC1 HPC DP8
	GTHE2_CHANNEL_X1Y28	FMC1 HPC DP9
	MGTREFCLK0	NC
	MGTREFCLK1	NC
MGT_BANK_118	GTHE2_CHANNEL_X1Y35	FMC1 HPC DP7
	GTHE2_CHANNEL_X1Y34	FMC1 HPC DP6
	GTHE2_CHANNEL_X1Y33	FMC1 HPC DP5
	GTHE2_CHANNEL_X1Y32	FMC1 HPC DP4
	MGTREFCLK0	FMC1 HPC GBT_CLK1
	MGTREFCLK1	FMC1 HPC GBT_CLK0
MGT_BANK_119	GTHE2_CHANNEL_X1Y39	FMC1 HPC DP3
	GTHE2_CHANNEL_X1Y38	FMC1 HPC DP2
	GTHE2_CHANNEL_X1Y37	FMC1 HPC DP1
	GTHE2_CHANNEL_X1Y36	FMC1 HPC DP0
	MGTREFCLK0	NC
	MGTREFCLK1	NC

For more information on the GTH transceivers see *7 Series FPGAs GTX/GTH Transceivers User Guide* (UG476) [Ref 6].

PCI Express Endpoint Connectivity

[Figure 1-2, callout 11]

The 8-lane PCI Express edge connector performs data transfers at the rate of 2.5 GT/s for a Gen1 application, 5.0 GT/s for a Gen2 application, and 8.0 GT/s for a Gen3 application. The PCIe transmit and receive signal datapaths have a characteristic impedance of $85\Omega \pm 10\%$. The PCIe clock is routed as a 100 Ω differential pair. The 7 series FPGAs GTH transceivers are used for multi-gigabit per second serial interfaces.

The XC7VX690T-2FFG1761C FPGA (-2 speed grade) included with the VC709 board supports up to Gen3 x8.

The PCIe clock is input from the edge connector. It is AC coupled to the FPGA through the MGTREFCLK1 pins of Quad 115. PCIE_CLK_Q0_P is connected to FPGA U1 pin AB8, and the _N net is connected to pin AB7. The PCI Express clock circuit is shown in Figure 1-14.

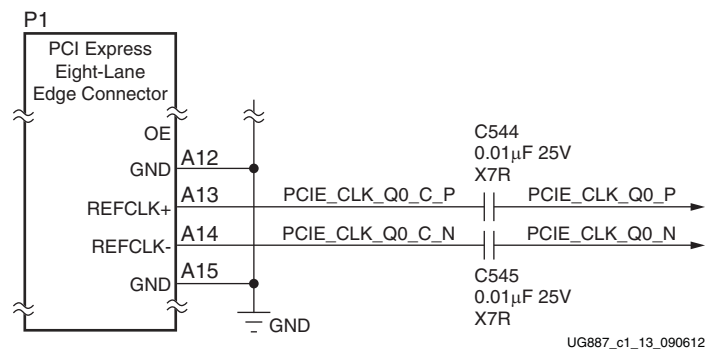

Figure 1-14: PCI Express Clock

PCIe lane width/size is selected through jumper J49 (Figure 1-15). The default lane size selection is 1-lane (J49 pins 1 and 2 jumpered).

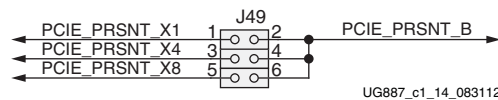

Figure 1-15: PCI Express Lane Size Select Jumper J49

Table 1-10 lists the PCIe edge connector connections at P1.

Table 1-10: PCIe Edge Connector Connections

Net Name	FPGA (U1) Pin	PCIe Edge Connector (P1)		Function	FFG1761 Placement
		Pin	Name		
PCIE_RX0_P	Y4	B14	PETp0	Integrated Endpoint block receive pair	GTHE2_CHANNEL_X1Y23
PCIE_RX0_N	Y3	B15	PETn0	Integrated Endpoint block receive pair	GTHE2_CHANNEL_X1Y23
PCIE_RX1_P	AA6	B19	PETp1	Integrated Endpoint block receive pair	GTHE2_CHANNEL_X1Y22
PCIE_RX1_N	AA5	B20	PETn1	Integrated Endpoint block receive pair	GTHE2_CHANNEL_X1Y22
PCIE_RX2_P	AB4	B23	PETp2	Integrated Endpoint block receive pair	GTHE2_CHANNEL_X1Y21
PCIE_RX2_N	AB3	B24	PETn2	Integrated Endpoint block receive pair	GTHE2_CHANNEL_X1Y21
PCIE_RX3_P	AC6	B27	PETp3	Integrated Endpoint block receive pair	GTHE2_CHANNEL_X1Y20
PCIE_RX3_N	AC5	B28	PETn3	Integrated Endpoint block receive pair	GTHE2_CHANNEL_X1Y20
PCIE_RX4_P	AD4	B33	PETp4	Integrated Endpoint block receive pair	GTHE2_CHANNEL_X1Y19
PCIE_RX4_N	AD3	B34	PETn4	Integrated Endpoint block receive pair	GTHE2_CHANNEL_X1Y19
PCIE_RX5_P	AE6	B37	PETp5	Integrated Endpoint block receive pair	GTHE2_CHANNEL_X1Y18
PCIE_RX5_N	AE5	B38	PETn5	Integrated Endpoint block receive pair	GTHE2_CHANNEL_X1Y18
PCIE_RX6_P	AF4	B41	PETp6	Integrated Endpoint block receive pair	GTHE2_CHANNEL_X1Y17
PCIE_RX6_N	AF3	B42	PETn6	Integrated Endpoint block receive pair	GTHE2_CHANNEL_X1Y17
PCIE_RX7_P	AG6	B45	PETp7	Integrated Endpoint block receive pair	GTHE2_CHANNEL_X1Y16
PCIE_RX7_N	AG5	B46	PETn7	Integrated Endpoint block receive pair	GTHE2_CHANNEL_X1Y16
PCIE_TX0_P	W2	A16	PERp0	Integrated Endpoint block transmit pair	GTHE2_CHANNEL_X1Y23
PCIE_TX0_N	W1	A17	PERn0	Integrated Endpoint block transmit pair	GTHE2_CHANNEL_X1Y23

Table 1-10: PCIe Edge Connector Connections (Cont'd)

Net Name	FPGA (U1) Pin	PCIe Edge Connector (P1)		Function	FFG1761 Placement
		Pin	Name		
PCIE_TX1_P	AA2	A21	PERp1	Integrated Endpoint block transmit pair	GTHE2_CHANNEL_X1Y22
PCIE_TX1_N	AA1	A22	PERn1	Integrated Endpoint block transmit pair	GTHE2_CHANNEL_X1Y22
PCIE_TX2_P	AC2	A25	PERp2	Integrated Endpoint block transmit pair	GTHE2_CHANNEL_X1Y21
PCIE_TX2_N	AC1	A26	PERn2	Integrated Endpoint block transmit pair	GTHE2_CHANNEL_X1Y21
PCIE_TX3_P	AE2	A29	PERp3	Integrated Endpoint block transmit pair	GTHE2_CHANNEL_X1Y20
PCIE_TX3_N	AE1	A30	PERn3	Integrated Endpoint block transmit pair	GTHE2_CHANNEL_X1Y20
PCIE_TX4_P	AG2	A35	PERp4	Integrated Endpoint block transmit pair	GTHE2_CHANNEL_X1Y19
PCIE_TX4_N	AG1	A36	PERn4	Integrated Endpoint block transmit pair	GTHE2_CHANNEL_X1Y19
PCIE_TX5_P	AH4	A39	PERp5	Integrated Endpoint block transmit pair	GTHE2_CHANNEL_X1Y18
PCIE_TX5_N	AH3	A40	PERn5	Integrated Endpoint block transmit pair	GTHE2_CHANNEL_X1Y18
PCIE_TX6_P	AJ2	A43	PERp6	Integrated Endpoint block transmit pair	GTHE2_CHANNEL_X1Y17
PCIE_TX6_N	AJ1	A44	PERn6	Integrated Endpoint block transmit pair	GTHE2_CHANNEL_X1Y17
PCIE_TX7_P	AK4	A47	PERp7	Integrated Endpoint block transmit pair	GTHE2_CHANNEL_X1Y16
PCIE_TX7_N	AK3	A48	PERn7	Integrated Endpoint block transmit pair	GTHE2_CHANNEL_X1Y16
PCIE_CLK_Q0_P	AB8	A13	REFCLK+	Integrated Endpoint block differential clock pair from PCIe	MGT_BANK_115
PCIE_CLK_Q0_N	AB7	A14	REFCLK-	Integrated Endpoint block differential clock pair from PCIe	MGT_BANK_115
PCIE_PRSNT_B	J49 2, 4, 6	A1	PRSNT#1	J49 Lane Size Select jumper	NA
PCIE_WAKE_B	AV33	B11	WAKE#	Integrated Endpoint block wake signal	U1 FPGA Bank13 Pin AV33
PCIE_PERST_B	AV35	A11	PERST	Integrated Endpoint block reset signal	U1 FPGA Bank13 Pin AV35

Table 1-11 lists the PCIe edge connector connections for Quad 115.

Table 1-11: GTH Quad 115 PCIe Edge Connector Connections

Quad 115 Pin Name	FPGA (U1) Pin	Net Name	PCIe Edge Connector (P1)		FFG1761 Placement
			Pin	Pin Name	
MGTXXP0_115_AE2	AE2	PCIE_TX3_P	A29	PERp3	GTHE2_CHANNEL_X1Y20
MGTXXN0_115_AE1	AE1	PCIE_TX3_N	A30	PERn3	GTHE2_CHANNEL_X1Y20
MGTXXP0_115_AC6	AC6	PCIE_RX3_P	B27	PETp3	GTHE2_CHANNEL_X1Y20
MGTXXN0_115_AC5	AC5	PCIE_RX3_N	B28	PETn3	GTHE2_CHANNEL_X1Y20
MGTXXP1_115_AC2	AC2	PCIE_TX2_P	A25	PERp2	GTHE2_CHANNEL_X1Y21
MGTXXN1_115_AC1	AC1	PCIE_TX2_N	A26	PERn2	GTHE2_CHANNEL_X1Y21
MGTXXP1_115_AB4	AB4	PCIE_RX2_P	B23	PETp2	GTHE2_CHANNEL_X1Y21
MGTXXN1_115_AB3	AB3	PCIE_RX2_N	B24	PETn2	GTHE2_CHANNEL_X1Y21
MGTXXP2_115_AA2	AA2	PCIE_TX1_P	A21	PERp1	GTHE2_CHANNEL_X1Y22
MGTXXN2_115_AA1	AA1	PCIE_TX1_N	A22	PERn1	GTHE2_CHANNEL_X1Y22
MGTXXP2_115_AA6	AA6	PCIE_RX1_P	B19	PETp1	GTHE2_CHANNEL_X1Y22
MGTXXN2_115_AA5	AA5	PCIE_RX1_N	B20	PETn1	GTHE2_CHANNEL_X1Y22
MGTXXP3_115_W2	W2	PCIE_TX0_P	A16	PERp0	GTHE2_CHANNEL_X1Y23
MGTXXN3_115_W1	W1	PCIE_TX0_N	A17	PERn0	GTHE2_CHANNEL_X1Y23
MGTXXP3_115_Y4	Y4	PCIE_RX0_P	B14	PETp0	GTHE2_CHANNEL_X1Y23
MGTXXN3_115_Y3	Y3	PCIE_RX0_N	B15	PETn0	GTHE2_CHANNEL_X1Y23
MGTREFCLK0P_115_Y8	Y8	NC			MGT_BANK_115
MGTREFCLK0N_115_Y7	Y7	NC			MGT_BANK_115
MGTREFCLK1P_115_AB8	AB8	PCIE_CLK_Q0_N	A13	REFCLK-	MGT_BANK_115
MGTREFCLK1N_115_AB7	AB7	PCIE_CLK_Q0_P	A14	REFCLK+	MGT_BANK_115

Table 1-12 lists the PCIe edge connector connections for Quad 114.

Table 1-12: GTH Quad 114 PCIe Edge Connector Connections

Quad 114 Pin Name	FPGA (U1) Pin	Net Name	PCIe Edge Connector (P1)		FFG1761 Placement
			Pin	Pin Name	
MGTXXP0_114_AK4	AK4	PCIE_TX7_P	A47	PERp7	GTHE2_CHANNEL_X1Y16
MGTXXN0_114_AK3	AK3	PCIE_TX7_N	A48	PERn7	GTHE2_CHANNEL_X1Y16
MGTXXP0_114_AG6	AG6	PCIE_RX7_P	B45	PETp7	GTHE2_CHANNEL_X1Y16
MGTXXN0_114_AG5	AG5	PCIE_RX7_N	B46	PETn7	GTHE2_CHANNEL_X1Y16
MGTXXP1_114_AJ2	AJ2	PCIE_TX6_P	A43	PERp6	GTHE2_CHANNEL_X1Y17
MGTXXN1_114_AJ1	AJ1	PCIE_TX6_N	A44	PERn6	GTHE2_CHANNEL_X1Y17
MGTXXP1_114_AF4	AF4	PCIE_RX6_P	B41	PETp6	GTHE2_CHANNEL_X1Y17
MGTXXN1_114_AF3	AF3	PCIE_RX6_N	B42	PETn6	GTHE2_CHANNEL_X1Y17
MGTXXP2_114_AH4	AH4	PCIE_TX5_P	A39	PERp5	GTHE2_CHANNEL_X1Y18
MGTXXN2_114_AH3	AH3	PCIE_TX5_N	A40	PERn5	GTHE2_CHANNEL_X1Y18
MGTXXP2_114_AE6	AE6	PCIE_RX5_P	B37	PETp5	GTHE2_CHANNEL_X1Y18
MGTXXN2_114_AE5	AE5	PCIE_RX5_N	B38	PETn5	GTHE2_CHANNEL_X1Y18
MGTXXP3_114_AG2	AG2	PCIE_TX4_P	A35	PERp4	GTHE2_CHANNEL_X1Y19
MGTXXN3_114_AG1	AG1	PCIE_TX4_N	A36	PERn4	GTHE2_CHANNEL_X1Y19
MGTXXP3_114_AD4	AD4	PCIE_RX4_P	B33	PETp4	GTHE2_CHANNEL_X1Y19
MGTXXN3_114_AD3	AD3	PCIE_RX4_N	B34	PETn4	GTHE2_CHANNEL_X1Y19
MGTREFCLK0P_114_AD8	AD8	NC			MGT_BANK_114
MGTREFCLK0N_114_AD7	AD7	NC			MGT_BANK_114
MGTREFCLK1P_114_AF8	AF8	NC			MGT_BANK_114
MGTREFCLK1N_114_AF7	AF7	NC			MGT_BANK_114

The PCIe edge connector P1 has two LVCMOS18 signals connected to the XCVX690T FPGA U1. The nets PCIE_PERST (P1.A11) and PCIE_WAKE_B (P1.B11) are level-shifted to 1.8V at U38, and are connected to the XCVX690T FPGA U1 bank 13 pins AV35 and AV33, respectively.

For more information refer to *7 Series FPGAs GTX/GTH Transceivers User Guide* (UG476) [Ref 6] and *7 Series FPGAs Integrated Block for PCI Express User Guide* (PG054) [Ref 7].

SFP/SFP+ Module Connectors

[Figure 1-2, callout 12]

The VC709 board supports four small form-factor pluggable (SFP+) connector and cage assemblies P2–P5 that accept SFP or SFP+ modules. Figure 1-16 shows an example of the SFP+ module connector circuitry replicated for each module.

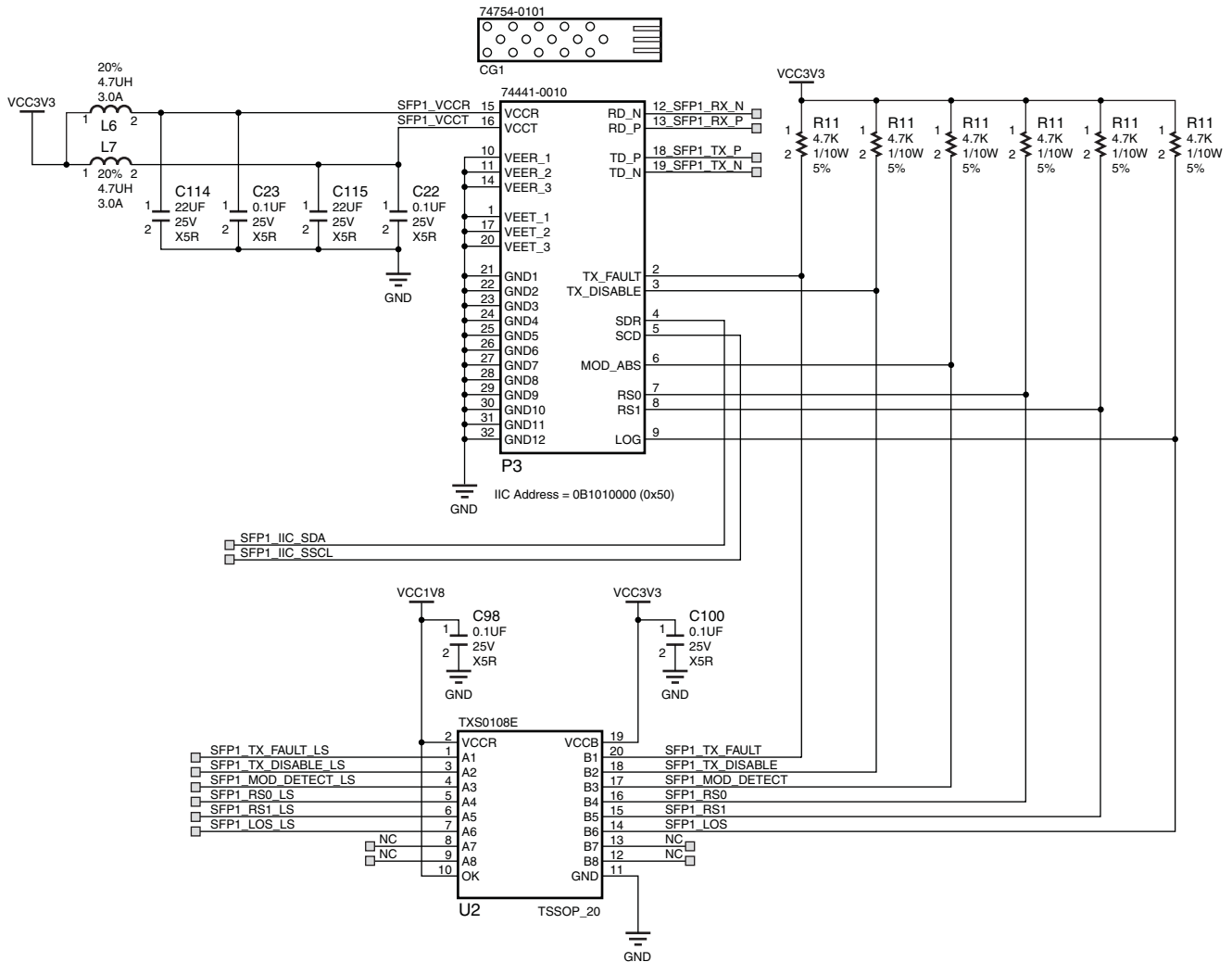

UG887_C1_15_031616

Figure 1-16: SFP+ Module Connector Circuit (Typical at Four Locations)

Table 1-13 lists the SFP+ module RX and TX connections to the FPGA.

Table 1-13: **FPGA U1 to SFP+ Module Connections**

XCVX690T (U1) Pin	Net Name	SFP+ Module	
		Pin Number	Pin Name
SFP+ Module 1 (P3)			
AP4	SFP1_TX_P	18	TX_P
AP3	SFP1_TX_N	19	TX_N
AN6	SFP1_RX_P	13	RD_P
AN5	SFP1_RX_N	12	RD_N
SFP+ Module 2 (P2)			
AN2	SFP2_TX_P	18	TX_P
AN1	SFP2_TX_N	19	TX_N
AM8	SFP2_RX_P	13	RD_P
AM7	SFP2_RX_N	12	RD_N
SFP+ Module 3 (P4)			
AM4	SFP3_TX_P	18	TX_P
AM3	SFP3_TX_N	19	TX_N
AL6	SFP3_RX_P	13	RD_P
AL5	SFP3_RX_N	12	RD_N
SFP+ Module 4 (P5)			
AL2	SFP4_TX_P	18	TX_P
AL1	SFP4_TX_N	19	TX_N
AJ6	SFP4_RX_P	13	RD_P
AJ5	SFP4_RX_N	12	RD_N

Table 1-14 lists the SFP+ module control and status connections to the FPGA.

Table 1-14: **SFP+ Module Control and Status**

XCVX690T (U1) Pin	Net Name	I/O Standard	SFP+ Module	
			Pin Number	Pin Name
SFP+ Module 1 (P3)				
Y38	SFP1_TX_FAULT	LVC MOS18	2	TX_FAULT
AB42	SFP1_MOD_DETECT	LVC MOS18	6	MOD_ABS
W40	SFP1_RS0	LVC MOS18	7	RS0
Y40	SFP1_RS1	LVC MOS18	9	RS1
Y39	SFP1_LOS	LVC MOS18	8	LOS
AB41	SFP1_TX_DISABLE	LVC MOS18	3	TX_DISABLE
SFP+ Module 2 (P2)				
AA39	SFP2_TX_FAULT	LVC MOS18	2	TX_FAULT
AA42	SFP2_MOD_DETECT	LVC MOS18	6	MOD_ABS
AB38	SFP2_RS0	LVC MOS18	7	RS0
AB39	SFP2_RS1	LVC MOS18	9	RS1
AA40	SFP2_LOS	LVC MOS18	8	LOS
Y42	SFP2_TX_DISABLE	LVC MOS18	3	TX_DISABLE
SFP+ Module 3 (P4)				
AA41	SFP3_TX_FAULT	LVC MOS18	2	TX_FAULT
AC39	SFP3_MOD_DETECT	LVC MOS18	6	MOD_ABS
AD42	SFP3_RS0	LVC MOS18	7	RS0
AE42	SFP3_RS1	LVC MOS18	9	RS1
AD38	SFP3_LOS	LVC MOS18	8	LOS
AC38	SFP3_TX_DISABLE	LVC MOS18	3	TX_DISABLE
SFP+ Module 4 (P5)				
AE38	SFP4_TX_FAULT	LVC MOS18	2	TX_FAULT
AC41	SFP4_MOD_DETECT	LVC MOS18	6	MOD_ABS
AE39	SFP4_RS0	LVC MOS18	7	RS0
AE40	SFP4_RS1	LVC MOS18	9	RS1
AD40	SFP4_LOS	LVC MOS18	8	LOS
AC40	SFP4_TX_DISABLE	LVC MOS18	3	TX_DISABLE

Note: The six control/status signals to/from each SFP+ connector are routed through a level shifter.

USB-to-UART Bridge

[Figure 1-2, callout 13]

The VC709 board contains a Silicon Labs CP2103GM USB-to-UART bridge device (U44) which allows a connection to a host computer with a USB port. The USB cable is supplied in the VC709 evaluation kit (type-A end to host computer, type mini-B end to VC709 board connector J17). The CP2103GM is powered by the USB 5V provided by the host PC when the USB cable is plugged into the USB port on the VC709 board.

Xilinx UART IP is expected to be implemented in the FPGA fabric. The FPGA supports the USB-to-UART bridge using four signal pins: Transmit (TX), Receive (RX), Request to Send (RTS), and Clear to Send (CTS).

Silicon Labs provides royalty-free Virtual COM Port (VCP) drivers for the host computer. These drivers permit the CP2103GM USB-to-UART bridge to appear as a COM port to communications application software (for example, TeraTerm or HyperTerm) that runs on the host computer. The VCP device drivers must be installed on the host PC prior to establishing communications with the VC709 board.

The USB Connector pin assignments and signal definitions between J17 and U44 are listed in [Table 1-15](#).

Table 1-15: USB Connector J17 Pin Assignments and Signal Definitions

USB Connector (J17)		Net Name	Description	CP2103GM (U44)	
Pin	Name			Pin	Name
1	VBUS	USB_UART_VBUS	+5V VBUS powered	7	REGIN
				8	VBUS
2	D_N	USB_D_N	Bidirectional differential serial data (N-side)	4	D -
3	D_P	USB_D_P	Bidirectional differential serial data (P-side)	3	D +
4	GND	USB_UART_GND	Signal ground	2	GND1
				29	CNR_GND

[Table 1-16](#) shows the USB connections between the FPGA and the UART.

Table 1-16: FPGA to UART Connections

FPGA (U1)				Schematic Net Name	CP2103GM UART (U44)		
Pin	Function	Direction	I/O Standard		Pin	Function	Direction
AR34	RTS	Output	LVC MOS18	USB_UART_CTS	22	CTS	Input
AT32	CTS	Input	LVC MOS18	USB_UART_RTS	23	RTS	Output
AU36	TX	Output	LVC MOS18	USB_UART_RX	24	RXD	Input
AU33	RX	Input	LVC MOS18	USB_UART_TX	25	TXD	Output

Refer to the [Silicon Labs](#) website for technical information on the CP2103GM and the VCP drivers.

I2C Bus

[Figure 1-2, callout 14, 15]

The VC709 board implements a single I²C port on the FPGA (IIC_SDA_MAIN, pin AU32; IIC_SDA_SCL, pin AT35), which is routed through a TI Semiconductor PCA9548A 1-to-8 channel I²C bus switch (U52). The bus switch can operate at speeds up to 400 kHz.

The bus switch I²C address is 0x74 (0b01110100) and must be addressed and configured to select the desired downstream device.

The four SFP+ connectors SFP1 (P3), SFP2 (P2), SFP3 (P4), and SFP4 (P5) are addressed through a secondary PCA9546A 1-to-4 channel I²C bus switch (U14). The VC709 board I²C bus topology is shown in Figure 1-17.

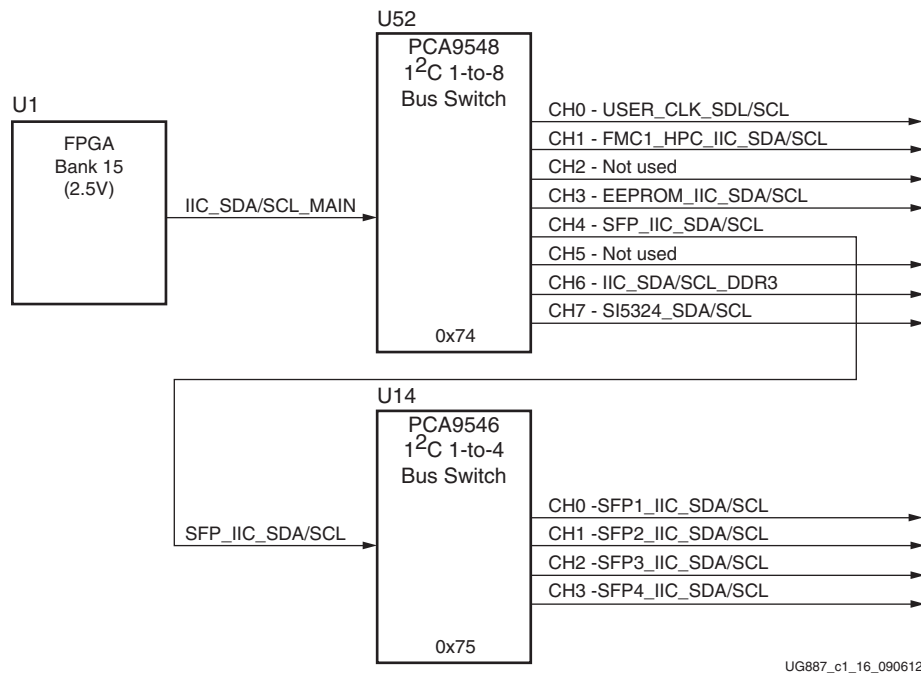

Figure 1-17: I²C Bus Topology

User applications that communicate with devices on one of the downstream I²C buses must first set up a path to the desired bus through the U52 bus switch at I²C address 0x74 (0b1110100). Table 1-17 lists the address for each bus. The secondary (SFP+ access) bus switch U14 is at I²C address 0x75 (0b1110101) and the SFP+ modules all have the same address 0x50 (0b1010000).

Table 1-17: I²C Bus Addresses

I ² C Bus	I ² C Switch Position	I ² C Address
PCA9548	NA	0b1110100
USER_CLK_SDL/SCL	0	0b1011101
FMC1_HPC_IIC_SDA/SCL	1	0bxxxxx00
NOT USED	2	NOT USED

Table 1-17: I²C Bus Addresses (Cont'd)

I ² C Bus	I ² C Switch Position	I ² C Address
EEPROM_IIC_SDA/SCL	3	0b1010100
PCA9546 (SFP1–SFP4)	4	0b1110101
NOT USED	5	NOT USED
IIC_SDA/SCL_DDR3 J1 IIC_SDA/SCL_DDR3 J3	6	0b1010001, 0b0011001 0b1010010, 0b0011010
Si5324_SDA/SCL	7	0b1101000

Notes:

1. Use the PCA9548 (U52) at I²C address 0x74 (0b01110100) to set up the path to these buses.

The U52 PCA9548 I2C bus MUX has three LVCMOS18 connections to the XCVC190T FPGA U1.

- U52 pin 19 net IIC_SCL_MAIN is level-shifted to 1.8V by Q16 and is connected to U1 bank 13 pin AT35.
- U52 pin 20 net IIC_SDA_MAIN is level-shifted to 1.8V by Q17 and is connected to U1 bank 13 pin AU32.
- U52 pin 24 net IIC_MUX_RESET_B is level-shifted to 1.8V by U70 and is connected to U1 bank 15 pin AY42. Both I2C switches U52 and U14 have a common reset net IIC_MUX_RESET_B. This is an active-Low signal and must be driven High (FPGA U1 pin AY42) to enable I2C bus transactions between the FPGA U1 and the other components on the I2C bus.

Information about the PCA9546A and PCA9548A is available on the [Texas Instruments](http://www.ti.com) website.

Status LEDs

[Figure 1-2, callout 24]

Table 1-18 defines the status LEDs. For user-controlled LEDs, see [User I/O](#).

Table 1-18: Status LEDs

Reference Designator	Signal Name	Color	Description
DS1	FPGA_INIT_B	GREEN/RED	GREEN: FPGA initialization successful RED: FPGA initialization in progress or configuration CRC failure
DS10	FPGA_DONE	GREEN	FPGA configured successfully
DS14	PWRCTL1_VCC4A_PG	GREEN	FMC1 HPC power good
DS16	VCC12_P_IN	GREEN	12V power ON
DS17	PWRCTL_PWRGOOD	GREEN	TI power system power good
DS18	LINEAR_POWER_GOOD	GREEN	DDR3 SODIMMs VTT power good

User I/O

[Figure 1-2, callout 16, 18]

The VC709 board provides the following user and general purpose I/O capabilities:

- Eight user LEDs (callout 16)
 - GPIO_LED_[7-0]: DS9, DS8, DS7, DS6, DS5, DS4, DS3, DS2
- Five user pushbuttons and reset switch (callout 17)
 - GPIO_SW_[NESWC]: SW3, SW4, SW5, SW7, SW6
 - CPU_RESET: SW8
- 8-position user DIP switch (callout 18)
 - GPIO_DIP_SW[7-0]: SW2

User LEDs

Figure 1-18 shows the user LED circuits.

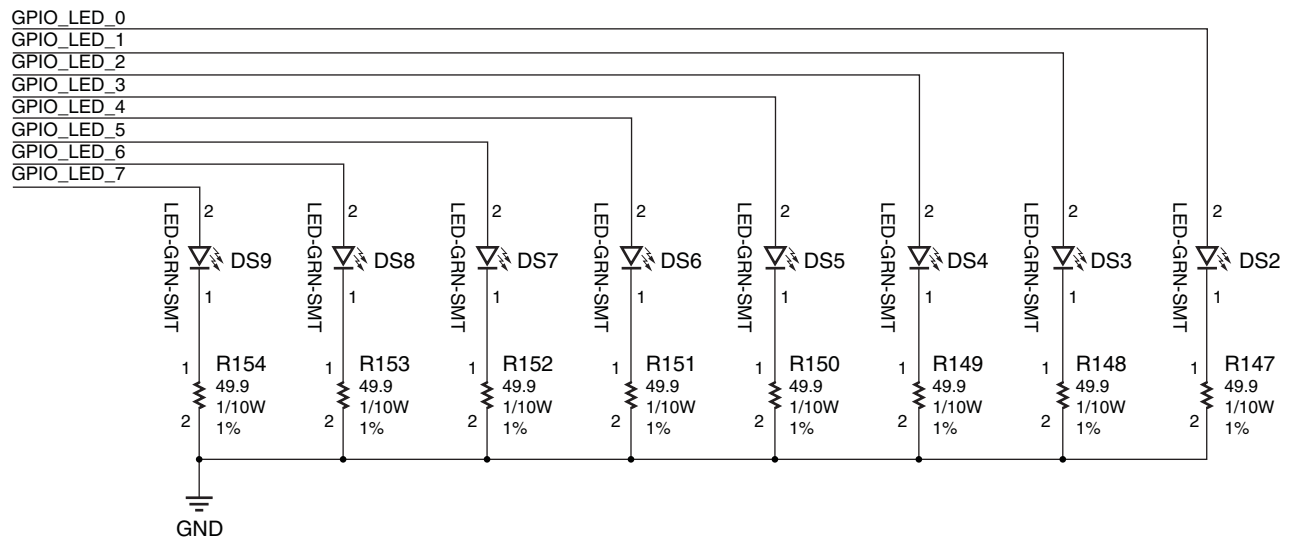

UG887_c1_17_090612

Figure 1-18: User LEDs

User Pushbuttons

Figure 1-19 shows the user pushbutton switch circuits.

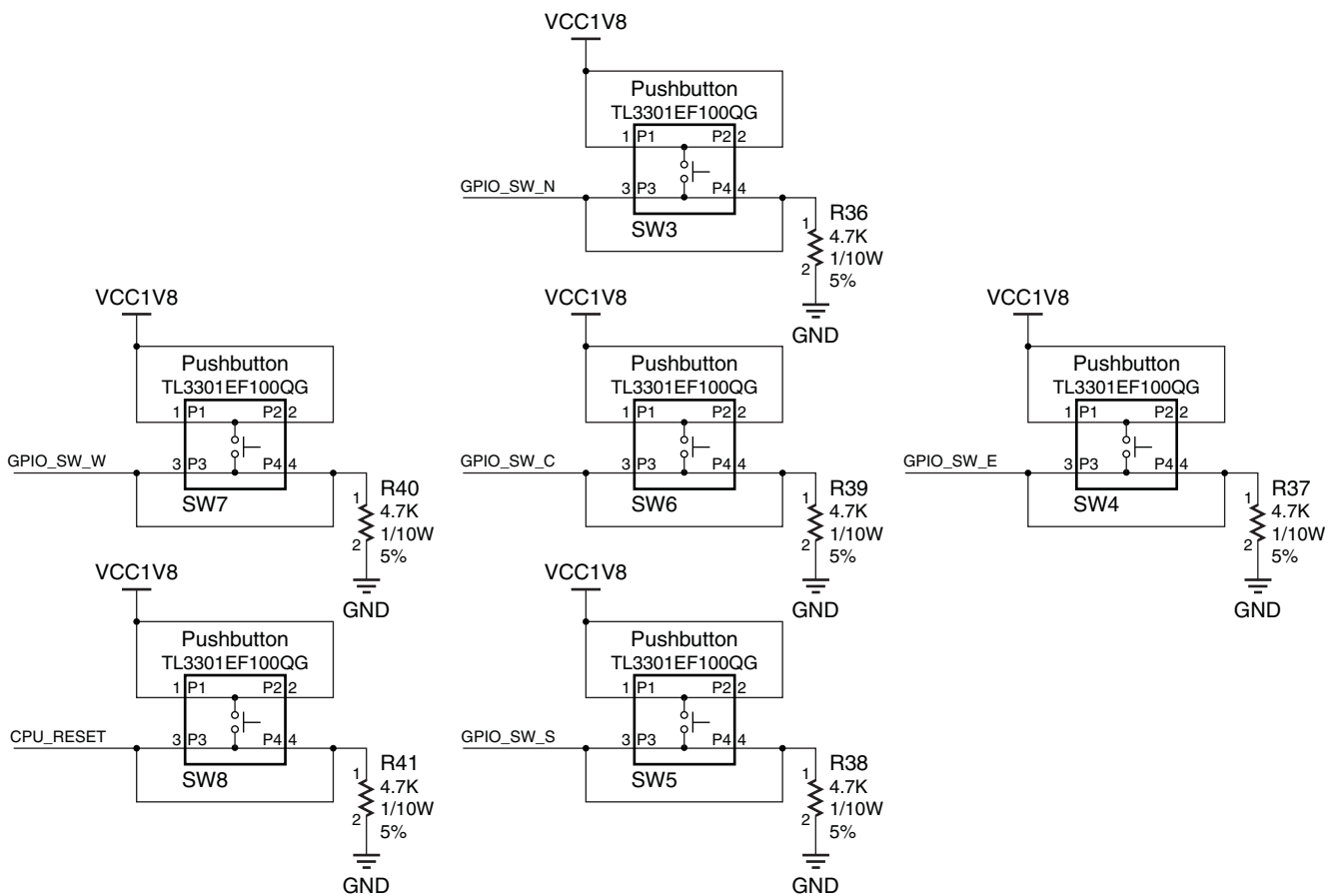

UG887_c1_18_090612

Figure 1-19: User Pushbuttons

Figure 1-20 shows the GPIO DIP switch circuit.

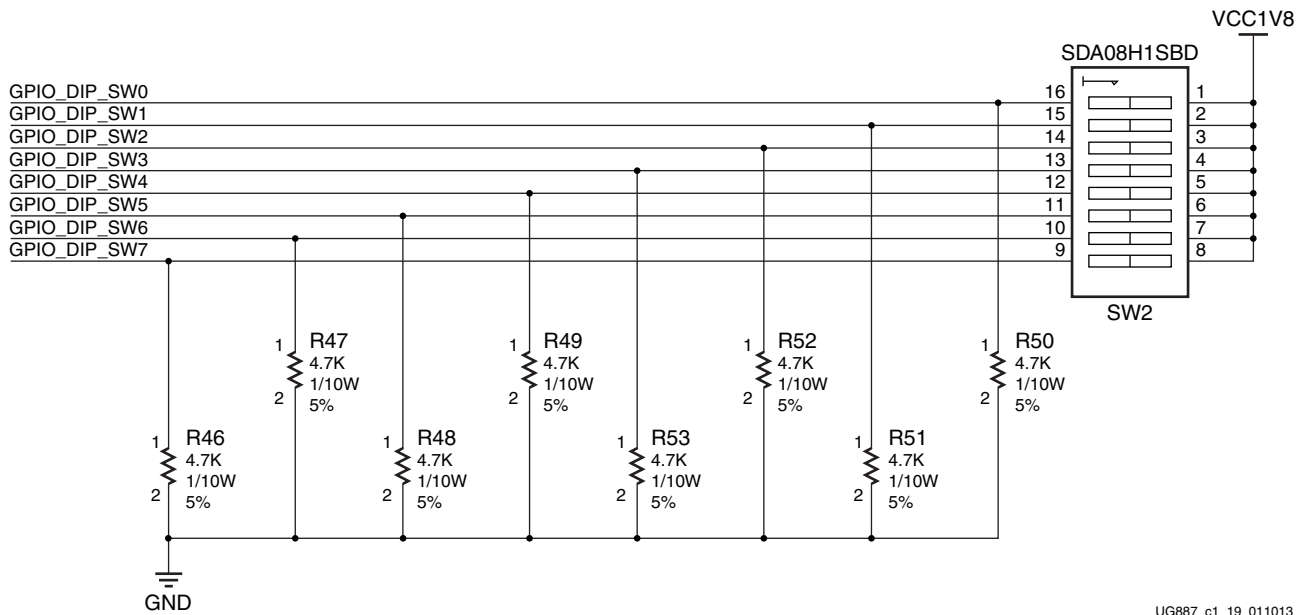

Figure 1-20: GPIO DIP Switch

Table 1-19 lists the GPIO connections to FPGA U1.

Table 1-19: GPIO Connections to FPGA U1

XCVX690T (U1) Pin	Net Name	I/O Standard	GPIO Pin
Indicator LEDs (Active-High)			
AM39	GPIO_LED_0	LVCMOS18	DS2.2
AN39	GPIO_LED_1	LVCMOS18	DS3.2
AR37	GPIO_LED_2	LVCMOS18	DS4.2
AT37	GPIO_LED_3	LVCMOS18	DS5.2
AR35	GPIO_LED_4	LVCMOS18	DS6.2
AP41	GPIO_LED_5	LVCMOS18	DS7.2
AP42	GPIO_LED_6	LVCMOS18	DS8.2
AU39	GPIO_LED_7	LVCMOS18	DS9.2
Directional Pushbutton Switches			
AR40	GPIO_SW_N	LVCMOS18	SW3.3
AU38	GPIO_SW_E	LVCMOS18	SW4.3
AP40	GPIO_SW_S	LVCMOS18	SW5.3
AW40	GPIO_SW_W	LVCMOS18	SW7.3
AV39	GPIO_SW_C	LVCMOS18	SW6.3
8-Pole DIP Switch			

Table 1-19: GPIO Connections to FPGA U1 (Cont'd)

XCVX690T (U1) Pin	Net Name	I/O Standard	GPIO Pin
AV30	GPIO_DIP_SW0	LVCMOS18	SW2.16
AY33	GPIO_DIP_SW1	LVCMOS18	SW2.15
BA31	GPIO_DIP_SW2	LVCMOS18	SW2.14
BA32	GPIO_DIP_SW3	LVCMOS18	SW2.13
AW30	GPIO_DIP_SW4	LVCMOS18	SW2.12
AY30	GPIO_DIP_SW5	LVCMOS18	SW2.11
BA30	GPIO_DIP_SW6	LVCMOS18	SW2.10
BB31	GPIO_DIP_SW7	LVCMOS18	SW2.9
Reset Pushbutton Switch			
AV40	CPU_RESET	LVCMOS18	SW8.3

Switches

[Figure 1-2, callout 19, 20, and 21]

The VC709 board includes a power and a configuration switch:

- FPGA_PROG_B, active-Low pushbutton switch SW9 (callout 19)
- Configuration mode DIP switch SW11 (callout 20)
- Power on/off slide switch SW12 (callout 21)

FPGA_PROG_B Pushbutton SW9 (Active-Low)

[Figure 1-2, callout 19]

Switch SW9 grounds the FPGA PROG_B pin when pressed. This action initiates an FPGA reconfiguration. The FPGA_PROG_B signal is connected to FPGA U1 pin AJ11.

See *7 Series FPGAs Configuration User Guide* (UG470) [Ref 3] for further details on configuring the 7 series FPGAs.

Figure 1-21 shows SW9.

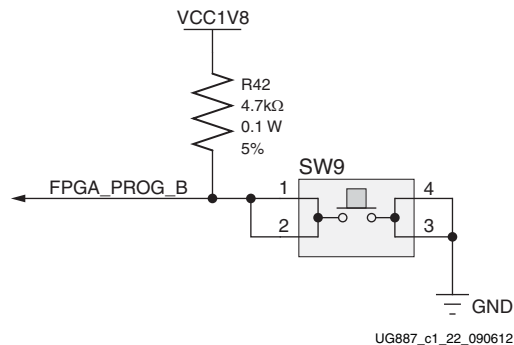

Figure 1-21: FPGA_PROG_B Pushbutton SW9

Configuration Mode and Upper Linear Flash Address Switch (SW11)

[Figure 1-2, callout 20]

FPGA Configuration Mode: The mode signals FPGA_M2, _M1, and _M0 are connected to FPGA U1 pins AJ10, AK10, and AL10, respectively. Configuration mode is used at power-up or when the PROG pushbutton is pressed.

Linear BPI Flash Upper Addresses: DIP switch SW11 positions 1 and 2 control the setting of address bits FLASH_A25 and FLASH_A24.

Figure 1-22 shows the SW11 circuit.

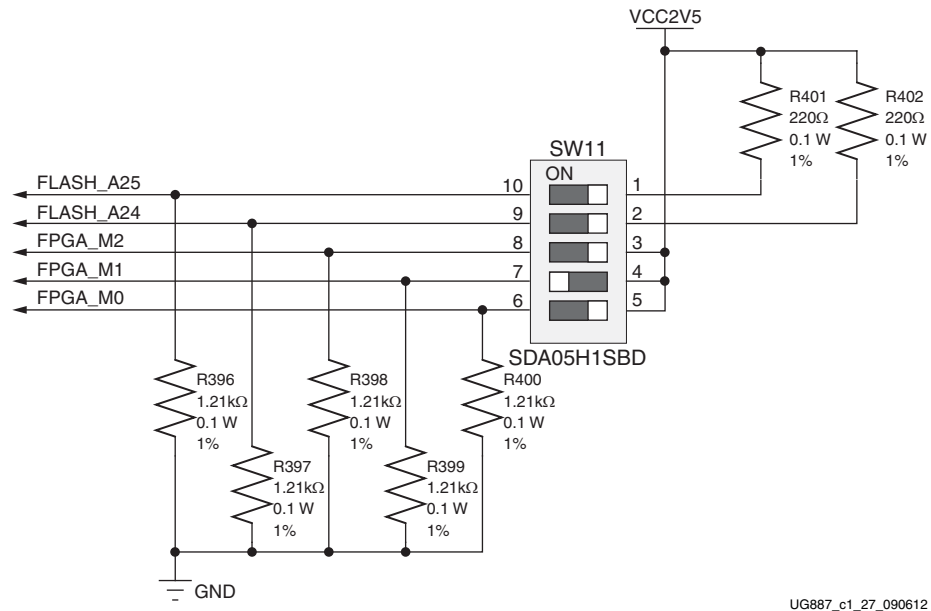

Figure 1-22: Configuration Mode and Upper Linear Flash Address Switch

Power On/Off Slide Switch SW12

[Figure 1-2, callout 21]

The VC709 board power switch is SW12. Sliding the switch actuator from the Off to On position applies 12V power from J18, a 6-pin mini-fit connector. Green LED DS16 illuminates when the VC709 board 12V power is on. See [Power Management](#) for details on the onboard power system.

Caution! Do NOT plug a PC ATX power supply 6-pin connector into J18 on the VC709 board. The ATX 6-pin connector has a different pinout than J18. Connecting an ATX 6-pin connector into J18 damages the VC709 board and voids the board warranty.

The VC709 evaluation kit provides the adapter cable shown in [Figure 1-23](#) for powering the VC709 board from the ATX power supply 4-pin peripheral connector. The Xilinx part number for this cable is 2600304, and is equivalent to Sourcegate Technologies part number AZCBL-WH-1109. For information on ordering this cable, see [\[Ref 21\]](#).



UG887_c1_20_083112

Figure 1-23: ATX Power Supply Adapter Cable

Figure 1-24 shows the power connector J18, power switch SW12, and indicator LED DS16.

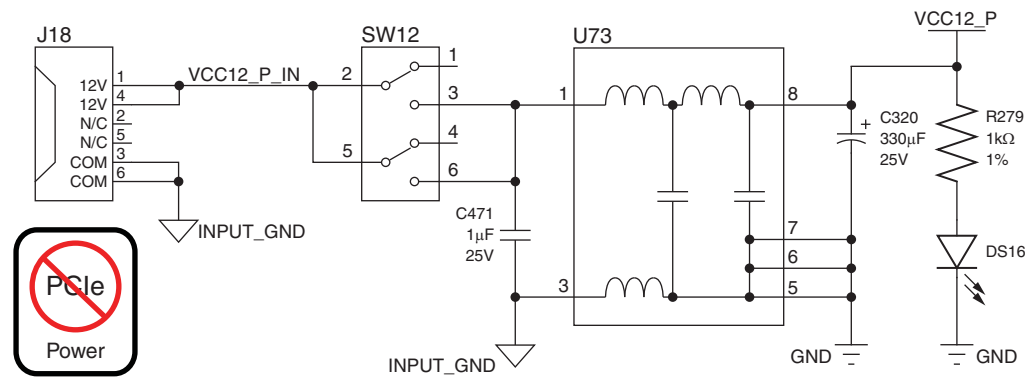

UG887_c1_21_090612

Figure 1-24: Power On/Off Switch SW15

VITA 57.1 FMC1 HPC Connector (Partially Populated)

[Figure 1-2, callout 22]

The VC709 board implements one instance of the FMC HPC VITA 57.1 specification connector. This section discusses the FMC1 HPC J35 connector.

Note: The FMC1 HPC J35 connector is a keyed connector oriented so that a plug-on card faces away from the VC709 board.

The VITA 57.1 FMC standard calls a high pin count (HPC), 400 pin 10 x 40 position form factor connector. The 10 x 40 rows of an FMC HPC connector provides pins for up to:

- 160 single-ended or 80 differential user-defined signals
- 10 GTH transceivers
- 2 GTH clocks
- 4 differential clocks
- 159 ground and 15 power connections

The VC709 board FMC1 HPC connector J35 implements a subset of the maximum signal and clock connectivity capabilities:

- 80 differential user-defined pairs:
 - 34 LA pairs (LA00-LA33)
 - 24 HA pairs (HA00-HA23)
 - 22 HB pairs (HB00-HB21)

- 10 GTH transceivers
- 2 GTH clocks
- 2 differential clocks

The FMC1 HPC signals are distributed across GTH Quads 117, 118, and 119.

The VC709 board VADJ voltage for the FMC1 HPC (J35) connector is fixed at 1.8V.

Signaling speed ratings:

- Single-ended: 9 GHz (18 Gb/s)
- Differential
 - Optimal vertical: 9 GHz (18 Gb/s)
 - Optimal horizontal: 16 GHz (32 Gb/s)
 - High Density Vertical: 7 GHz (15 Gb/s)

Mechanical specifications:

- Samtec SEAM/SEAF Series
- 1.27 mm x 1.27 mm (0.050-inch x 0.050-inch) pitch

The Samtec connector system is rated for signaling speeds up to 9 GHz (18 Gb/s) based on a –3 dB insertion loss point within a two-level signaling environment.

Table 1-20 shows the FMC HPC connector J35 connections to FPGA U1.

Table 1-20: VITA 57.1 FMC HPC J35 Connections to FPGA U1

J35 FMC1 HPC Pin	Net Name	I/O Standard	XCVX690T (U1) Pin	J35 FMC1 HPC Pin	Net Name	I/O Standard	XCVX690T (U1) Pin
A2	FMC1_HPC_DP1_M2C_P	(I)	C6	B1	NC	NA	NA
A3	FMC1_HPC_DP1_M2C_N	(I)	C5	B4	FMC1_HPC_DP9_M2C_P	(I)	N6
A6	FMC1_HPC_DP2_M2C_P	(I)	B8	B5	FMC1_HPC_DP9_M2C_N	(I)	N5
A7	FMC1_HPC_DP2_M2C_N	(I)	B7	B8	FMC1_HPC_DP8_M2C_P	(I)	P8
A10	FMC1_HPC_DP3_M2C_P	(I)	A6	B9	FMC1_HPC_DP8_M2C_N	(I)	P7
A11	FMC1_HPC_DP3_M2C_N	(I)	A5	B12	FMC1_HPC_DP7_M2C_P	(I)	E6
A14	FMC1_HPC_DP4_M2C_P	(I)	H8	B13	FMC1_HPC_DP7_M2C_N	(I)	E5
A15	FMC1_HPC_DP4_M2C_N	(I)	H7	B16	FMC1_HPC_DP6_M2C_P	(I)	F8
A18	FMC1_HPC_DP5_M2C_P	(I)	G6	B17	FMC1_HPC_DP6_M2C_N	(I)	F7
A19	FMC1_HPC_DP5_M2C_N	(I)	G5	B20	FMC1_HPC_GBTCLK1_M2C_P	(I)	E10
A22	FMC1_HPC_DP1_C2M_P	(I)	D4	B21	FMC1_HPC_GBTCLK1_M2C_N	(I)	E9
A23	FMC1_HPC_DP1_C2M_N	(I)	D3	B24	FMC1_HPC_DP9_C2M_P	(I)	M4
A26	FMC1_HPC_DP2_C2M_P	(I)	C2	B25	FMC1_HPC_DP9_C2M_N	(I)	M3
A27	FMC1_HPC_DP2_C2M_N	(I)	C1	B28	FMC1_HPC_DP8_C2M_P	(I)	N2
A30	FMC1_HPC_DP3_C2M_P	(I)	B4	B29	FMC1_HPC_DP8_C2M_N	(I)	N1
A31	FMC1_HPC_DP3_C2M_N	(I)	B3	B32	FMC1_HPC_DP7_C2M_P	(I)	F4
A34	FMC1_HPC_DP4_C2M_P	(I)	J2	B33	FMC1_HPC_DP7_C2M_N	(I)	F3
A35	FMC1_HPC_DP4_C2M_N	(I)	J1	B36	FMC1_HPC_DP6_C2M_P	(I)	G2

Table 1-20: VITA 57.1 FMC HPC J35 Connections to FPGA U1 (Cont'd)

J35 FMC1 HPC Pin	Net Name	I/O Standard	XCVX690T (U1) Pin	J35 FMC1 HPC Pin	Net Name	I/O Standard	XCVX690T (U1) Pin
A38	FMC1_HPC_DP5_C2M_P	(I)	H4	B37	FMC1_HPC_DP6_C2M_N	(I)	G1
A39	FMC1_HPC_DP5_C2M_N	(I)	H3	B40	NC		NA
C2	FMC1_HPC_DP0_C2M_P	(I)	E2	D1	PWRCTL1_VCC4B_PG	LVC MOS18	AL32
C3	FMC1_HPC_DP0_C2M_N	(I)	E1	D4	FMC1_HPC_GBTCLK0_M2C_P	(I)	G10
C6	FMC1_HPC_DP0_M2C_P	(I)	D8	D5	FMC1_HPC_GBTCLK0_M2C_N	(I)	G9
C7	FMC1_HPC_DP0_M2C_N	(I)	D7	D8	FMC1_HPC_LA01_CC_P	LVC MOS18	J40
C10	FMC1_HPC_LA06_P	LVC MOS18	K42	D9	FMC1_HPC_LA01_CC_N	LVC MOS18	J41
C11	FMC1_HPC_LA06_N	LVC MOS18	J42	D11	FMC1_HPC_LA05_P	LVC MOS18	M41
C14	FMC1_HPC_LA10_P	LVC MOS18	N38	D12	FMC1_HPC_LA05_N	LVC MOS18	L41
C15	FMC1_HPC_LA10_N	LVC MOS18	M39	D14	FMC1_HPC_LA09_P	LVC MOS18	R42
C18	FMC1_HPC_LA14_P	LVC MOS18	N39	D15	FMC1_HPC_LA09_N	LVC MOS18	P42
C19	FMC1_HPC_LA14_N	LVC MOS18	N40	D17	FMC1_HPC_LA13_P	LVC MOS18	H39
C22	FMC1_HPC_LA18_CC_P	LVC MOS18	M32	D18	FMC1_HPC_LA13_N	LVC MOS18	G39
C23	FMC1_HPC_LA18_CC_N	LVC MOS18	L32	D20	FMC1_HPC_LA17_CC_P	LVC MOS18	L31
C26	FMC1_HPC_LA27_P	LVC MOS18	J31	D21	FMC1_HPC_LA17_CC_N	LVC MOS18	K32
C27	FMC1_HPC_LA27_N	LVC MOS18	H31	D23	FMC1_HPC_LA23_P	LVC MOS18	P30
C30	FMC1_HPC_IIC_SCL	NA	U52.4	D24	FMC1_HPC_LA23_N	LVC MOS18	N31
C31	FMC1_HPC_IIC_SDA	NA	U52.3	D26	FMC1_HPC_LA26_P	LVC MOS18	J30
C34	GND	NA	NA	D27	FMC1_HPC_LA26_N	LVC MOS18	H30
C35	VCC12_P	NA	NA	D29	FMC1_HPC_TCK_BUF	NA	U19.14
C37	VCC12_P	NA	NA	D30	FMC1_TDI_BUF	NA	U19.18
C39	VCC3V3	NA	NA	D31	FMC1_TDO_FPGA_TDI	NA	T10
				D32	VCC3V3	NA	NA
				D33	FMC1_HPC_TMS_BUF	NA	U19.17
				D34	NC	NA	NA
				D35	GND	NA	NA
				D36	VCC3V3	NA	NA
				D38	VCC3V3	NA	NA
				D40	VCC3V3	NA	NA
E2	FMC1_HPC_HA01_CC_P	LVC MOS18	D35	F1	FMC1_HPC_PG_M2C	LVC MOS18	AN34
E3	FMC1_HPC_HA01_CC_N	LVC MOS18	D36	F4	FMC1_HPC_HA00_CC_P	LVC MOS18	E34
E6	FMC1_HPC_HA05_P	LVC MOS18	G32	F5	FMC1_HPC_HA00_CC_N	LVC MOS18	E35
E7	FMC1_HPC_HA05_N	LVC MOS18	F32	F7	FMC1_HPC_HA04_P	LVC MOS18	F34

Table 1-20: VITA 57.1 FMC HPC J35 Connections to FPGA U1 (Cont'd)

J35 FMC1 HPC Pin	Net Name	I/O Standard	XCVX690T (U1) Pin	J35 FMC1 HPC Pin	Net Name	I/O Standard	XCVX690T (U1) Pin
E9	FMC1_HPC_HA09_P	LVCMOS18	E32	F8	FMC1_HPC_HA04_N	LVCMOS18	F35
E10	FMC1_HPC_HA09_N	LVCMOS18	D32	F10	FMC1_HPC_HA08_P	LVCMOS18	J36
E12	FMC1_HPC_HA13_P	LVCMOS18	B36	F11	FMC1_HPC_HA08_N	LVCMOS18	H36
E13	FMC1_HPC_HA13_N	LVCMOS18	A37	F13	FMC1_HPC_HA12_P	LVCMOS18	B37
E15	FMC1_HPC_HA16_P	LVCMOS18	B39	F14	FMC1_HPC_HA12_N	LVCMOS18	B38
E16	FMC1_HPC_HA16_N	LVCMOS18	A39	F16	FMC1_HPC_HA15_P	LVCMOS18	C33
E18	FMC1_HPC_HA20_P	LVCMOS18	B34	F17	FMC1_HPC_HA15_N	LVCMOS18	C34
E19	FMC1_HPC_HA20_N	LVCMOS18	A34	F19	FMC1_HPC_HA19_P	LVCMOS18	B32
E21	FMC1_HPC_HB03_P	LVCMOS18	G28	F20	FMC1_HPC_HA19_N	LVCMOS18	B33
E22	FMC1_HPC_HB03_N	LVCMOS18	G29	F22	FMC1_HPC_HB02_P	LVCMOS18	K28
E24	FMC1_HPC_HB05_P	LVCMOS18	K27	F23	FMC1_HPC_HB02_N	LVCMOS18	J28
E25	FMC1_HPC_HB05_N	LVCMOS18	J27	F25	FMC1_HPC_HB04_P	LVCMOS18	H24
E27	FMC1_HPC_HB09_P	LVCMOS18	H23	F26	FMC1_HPC_HB04_N	LVCMOS18	G24
E28	FMC1_HPC_HB09_N	LVCMOS18	G23	F28	FMC1_HPC_HB08_P	LVCMOS18	H25
E30	FMC1_HPC_HB13_P	LVCMOS18	P25	F29	FMC1_HPC_HB08_N	LVCMOS18	H26
E31	FMC1_HPC_HB13_N	LVCMOS18	P26	F31	FMC1_HPC_HB12_P	LVCMOS18	K24
E33	FMC1_HPC_HB19_P	LVCMOS18	L25	F32	FMC1_HPC_HB12_N	LVCMOS18	K25
E34	FMC1_HPC_HB19_N	LVCMOS18	L26	F34	FMC1_HPC_HB16_P	LVCMOS18	N25
E36	FMC1_HPC_HB21_P	LVCMOS18	P22	F35	FMC1_HPC_HB16_N	LVCMOS18	N26
E37	FMC1_HPC_HB21_N	LVCMOS18	P23	F37	FMC1_HPC_HB20_P	LVCMOS18	P21
E39	VCC1V8	NA	NA	F38	FMC1_HPC_HB20_N	LVCMOS18	N21
				F40	VCC1V8	NA	NA
G2	FMC1_HPC_CLK1_M2C_P	LVCMOS18	N30	H1	NC	NA	NA
G3	FMC1_HPC_CLK1_M2C_N	LVCMOS18	M31	H2	FMC1_HPC_PRSNT_M2C	LVCMOS18	AM31
G6	FMC1_HPC_LA00_CC_P	LVCMOS18	K39	H4	FMC1_HPC_CLK0_M2C_P	LVCMOS18	L39
G7	FMC1_HPC_LA00_CC_N	LVCMOS18	K40	H5	FMC1_HPC_CLK0_M2C_N	LVCMOS18	L40
G9	FMC1_HPC_LA03_P	LVCMOS18	M42	H7	FMC1_HPC_LA02_P	LVCMOS18	P41
G10	FMC1_HPC_LA03_N	LVCMOS18	L42	H8	FMC1_HPC_LA02_N	LVCMOS18	N41
G12	FMC1_HPC_LA08_P	LVCMOS18	M37	H10	FMC1_HPC_LA04_P	LVCMOS18	H40
G13	FMC1_HPC_LA08_N	LVCMOS18	M38	H11	FMC1_HPC_LA04_N	LVCMOS18	H41
G15	FMC1_HPC_LA12_P	LVCMOS18	R40	H13	FMC1_HPC_LA07_P	LVCMOS18	G41
G16	FMC1_HPC_LA12_N	LVCMOS18	P40	H14	FMC1_HPC_LA07_N	LVCMOS18	G42
G18	FMC1_HPC_LA16_P	LVCMOS18	K37	H16	FMC1_HPC_LA11_P	LVCMOS18	F40
G19	FMC1_HPC_LA16_N	LVCMOS18	K38	H17	FMC1_HPC_LA11_N	LVCMOS18	F41

Table 1-20: VITA 57.1 FMC HPC J35 Connections to FPGA U1 (Cont'd)

J35 FMC1 HPC Pin	Net Name	I/O Standard	XCVX690T (U1) Pin	J35 FMC1 HPC Pin	Net Name	I/O Standard	XCVX690T (U1) Pin
G21	FMC1_HPC_LA20_P	LVCMOS18	Y29	H19	FMC1_HPC_LA15_P	LVCMOS18	M36
G22	FMC1_HPC_LA20_N	LVCMOS18	Y30	H20	FMC1_HPC_LA15_N	LVCMOS18	L37
G24	FMC1_HPC_LA22_P	LVCMOS18	R28	H22	FMC1_HPC_LA19_P	LVCMOS18	W30
G25	FMC1_HPC_LA22_N	LVCMOS18	P28	H23	FMC1_HPC_LA19_N	LVCMOS18	W31
G27	FMC1_HPC_LA25_P	LVCMOS18	K29	H25	FMC1_HPC_LA21_P	LVCMOS18	N28
G28	FMC1_HPC_LA25_N	LVCMOS18	K30	H26	FMC1_HPC_LA21_N	LVCMOS18	N29
G30	FMC1_HPC_LA29_P	LVCMOS18	T29	H28	FMC1_HPC_LA24_P	LVCMOS18	R30
G31	FMC1_HPC_LA29_N	LVCMOS18	T30	H29	FMC1_HPC_LA24_N	LVCMOS18	P31
G33	FMC1_HPC_LA31_P	LVCMOS18	M28	H31	FMC1_HPC_LA28_P	LVCMOS18	L29
G34	FMC1_HPC_LA31_N	LVCMOS18	M29	H32	FMC1_HPC_LA28_N	LVCMOS18	L30
G36	FMC1_HPC_LA33_P	LVCMOS18	U31	H34	FMC1_HPC_LA30_P	LVCMOS18	V30
G37	FMC1_HPC_LA33_N	LVCMOS18	T31	H35	FMC1_HPC_LA30_N	LVCMOS18	V31
G39	VCC1V8	NA	NA	H37	FMC1_HPC_LA32_P	LVCMOS18	V29
				H38	FMC1_HPC_LA32_N	LVCMOS18	U29
				H40	VCC1V8	NA	NA
J2	NC	NC	NA	K1	NC	NA	NA
J3	NC	NC	NA	K4	NC	NA	NA
J6	FMC1_HPC_HA03_P	LVCMOS18	H33	K5	NC	NA	NA
J7	FMC1_HPC_HA03_N	LVCMOS18	G33	K7	FMC1_HPC_HA02_P	LVCMOS18	E33
J9	FMC1_HPC_HA07_P	LVCMOS18	C38	K8	FMC1_HPC_HA02_N	LVCMOS18	D33
J10	FMC1_HPC_HA07_N	LVCMOS18	C39	K10	FMC1_HPC_HA06_P	LVCMOS18	G36
J12	FMC1_HPC_HA11_P	LVCMOS18	J37	K11	FMC1_HPC_HA06_N	LVCMOS18	G37
J13	FMC1_HPC_HA11_N	LVCMOS18	J38	K13	FMC1_HPC_HA10_P	LVCMOS18	H38
J15	FMC1_HPC_HA14_P	LVCMOS18	E37	K14	FMC1_HPC_HA10_N	LVCMOS18	G38
J16	FMC1_HPC_HA14_N	LVCMOS18	E38	K16	FMC1_HPC_HA17_CC_P	LVCMOS18	C35
J18	FMC1_HPC_HA18_P	LVCMOS18	F39	K17	FMC1_HPC_HA17_CC_N	LVCMOS18	C36
J19	FMC1_HPC_HA18_N	LVCMOS18	E39	K19	FMC1_HPC_HA21_P	LVCMOS18	D37
J21	FMC1_HPC_HA22_P	LVCMOS18	F36	K20	FMC1_HPC_HA21_N	LVCMOS18	D38
J22	FMC1_HPC_HA22_N	LVCMOS18	F37	K22	FMC1_HPC_HA23_P	LVCMOS18	A35
J24	FMC1_HPC_HB01_P	LVCMOS18	H28	K23	FMC1_HPC_HA23_N	LVCMOS18	A36
J25	FMC1_HPC_HB01_N	LVCMOS18	H29	K25	FMC1_HPC_HB00_CC_P	LVCMOS18	J25
J27	FMC1_HPC_HB07_P	LVCMOS18	G26	K26	FMC1_HPC_HB00_CC_N	LVCMOS18	J26
J28	FMC1_HPC_HB07_N	LVCMOS18	G27	K28	FMC1_HPC_HB06_CC_P	LVCMOS18	K23
J30	FMC1_HPC_HB11_P	LVCMOS18	K22	K29	FMC1_HPC_HB06_CC_N	LVCMOS18	J23

Table 1-20: VITA 57.1 FMC HPC J35 Connections to FPGA U1 (Cont'd)

J35 FMC1 HPC Pin	Net Name	I/O Standard	XCVX690T (U1) Pin	J35 FMC1 HPC Pin	Net Name	I/O Standard	XCVX690T (U1) Pin
J31	FMC1_HPC_HB11_N	LVC MOS18	J22	K31	FMC1_HPC_HB10_P	LVC MOS18	M22
J33	FMC1_HPC_HB15_P	LVC MOS18	M21	K32	FMC1_HPC_HB10_N	LVC MOS18	L22
J34	FMC1_HPC_HB15_N	LVC MOS18	L21	K34	FMC1_HPC_HB14_P	LVC MOS18	J21
J36	FMC1_HPC_HB18_P	LVC MOS18	G21	K35	FMC1_HPC_HB14_N	LVC MOS18	H21
J37	FMC1_HPC_HB18_N	LVC MOS18	G22	K37	FMC1_HPC_HB17_CC_P	LVC MOS18	M24
J39	FMC1_VIO_B_M2C ⁽¹⁾ ⁽³⁾			K38	FMC1_HPC_HB17_CC_N	LVC MOS18	L24
				K40	FMC1_VIO_B_M2C		

Notes:

1. No I/O standards are associated with MGT connections.
2. FMC1_VIO_B_M2C is sourced by a FMC card which supports the HB bus, when plugged onto the HPC connector J35.
3. FMC1_VIO_B_M2C is a variable voltage but it cannot exceed the fixed VADJ 1.8V value.

Power Management

[Figure 1-2, callout 26]

The VC709 board power distribution diagram is shown in Figure 1-25.

The PCB layout and power system have been designed to meet the recommended criteria described in *7 Series FPGAs PCB Design and Pin Planning Guide* (UG483) [Ref 8].

The J5 keyed PMBus connector has three LVC MOS18 connections to the XCVX690T FPGA U1.

- J5 pin 9 net PMBUS_CLK is level-shifted to 1.8V by Q8 and is connected to U1 bank 15 pin AW37.
- J5 pin 10 net PMBUS_DATA is level-shifted to 1.8V by Q6 and is connected to U1 bank 15 pin AY39.
- J5 pin 8 net PMBUS_ALERT is level-shifted to 1.8V by Q7 and is connected to U1 bank 15 pin AV38.

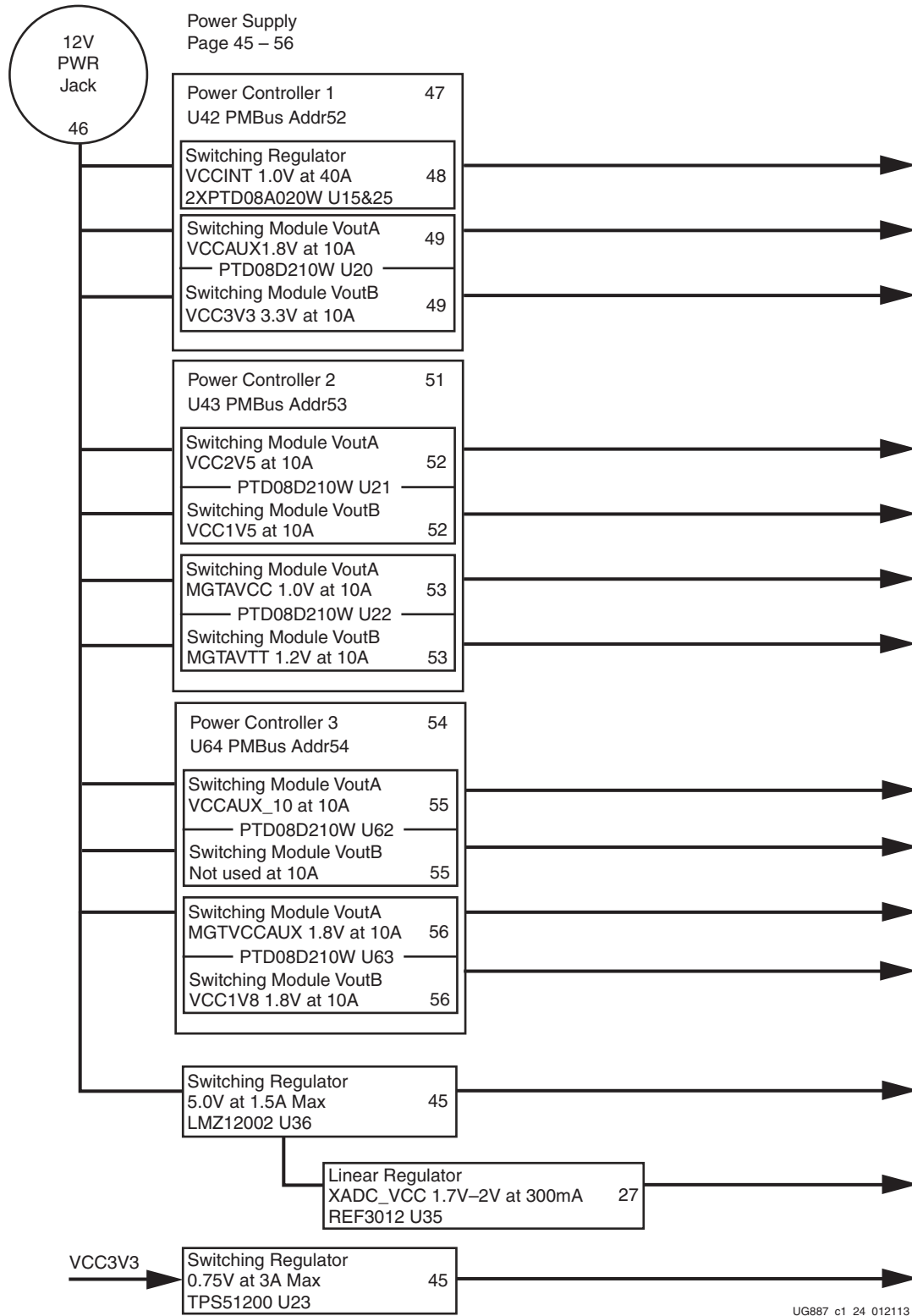

Figure 1-25: Onboard Power Regulators

The VC709 board uses power regulators and PMBus compliant digital PWM system controllers from [Texas Instrument digital power](#) to supply the core and auxiliary voltages listed in [Table 1-21](#). U10 is an ADP123 linear regulator from [Analog Devices](#).

Table 1-21: Onboard Power System Devices

Device Type	Reference Designator	Description	Power Rail Net Name	Power Rail Voltage	Schematic Page
Core voltage controller and regulators					
UCD9248PFC ⁽¹⁾	U42	PMBus Controller (Addr = 52)			47
PTD08A020W	U25/U15	Dual adjustable switching regulators 40A, 0.6V to 3.6V	VCCINT_FPGA	1.00V	48
PTD08D210W (V _{OUT A})	U20	½ of adjustable switching regulator dual 10A, 0.6V to 3.6V	VCCAUX	1.80V	49
PTD08D210W (V _{OUT B})		½ of adjustable switching regulator dual 10A, 0.6V to 3.6V	VCC3V3	3.30V	49
Auxiliary voltage controller and regulators					
UCD9248PFC ⁽²⁾	U43	PMBus Controller (Addr = 53)			51
PTD08D210W (V _{OUT A})	U21	½ of adjustable switching regulator dual 10A, 0.6V to 3.6V	VCC2V5_FPGA	2.50V	52
PTD08D210W (V _{OUT B})		½ of adjustable switching regulator dual 10A, 0.6V to 3.6V	VCC1V5_FPGA	1.50V	52
PTD08D210W (V _{OUT A})	U22	½ of adjustable switching regulator dual 10A, 0.6V to 3.6V	MGTAVCC	1.00V	53
PTD08D210W (V _{OUT B})		½ of adjustable switching regulator dual 10A, 0.6V to 3.6V	MGTAVTT	1.20V	53
Linear regulators					
UCD9248PFC ⁽³⁾	U64	PMBus Controller (Addr = 54)			54
PTD08D210W (V _{OUT A})	U62	½ of adjustable switching regulator dual 10A, 0.6V to 3.6V	VCCAUX_IO	2.00V	55
PTD08D210W (V _{OUT B})		½ of adjustable switching regulator dual 10A, 0.6V to 3.6V	NOT USED	1.00V	55
PTD08D210W (V _{OUT A})	U63	½ of adjustable switching regulator dual 10A, 0.6V to 3.6V	MGTVCCAUX	1.80V	56
PTD08D210W (V _{OUT B})		½ of adjustable switching regulator dual 10A, 0.6V to 3.6V	VCC1V8_FPGA ⁽⁴⁾	1.80V	56
LMZ12002	U36	Fixed linear regulator 2A	VCC5V0	5.00V	45
TPS51200DR	U23	Tracking regulator, 3A	VTTDDR	0.75V	45
ADP123	U10	Fixed linear regulator, 300 mA	XADC_VCC	1.80V	27

Table 1-21: Onboard Power System Devices (Cont'd)

Device Type	Reference Designator	Description	Power Rail Net Name	Power Rail Voltage	Schematic Page
REF3012	U35	Fixed linear voltage reference	XADC_VREF	1.25V	27

Notes:

1. See Table 1-22.
2. See Table 1-23.
3. See Table 1-24.
4. The FMC VADJ rail is fixed at 1.8V.

FMC_VADJ Voltage

The FMC VADJ rail is fixed at 1.8V (U63 V_{OUTB} VCC1V8).

Monitoring Voltage and Current

Voltage and current monitoring and control are available for selected power rails through Texas Instruments' Fusion Digital Power graphical user interface. The three onboard TI power controllers (U42 at address 52, U43 at address 53, and U64 at address 54) are wired to the same PMBus. The PMBus connector, J5, is provided for use with the TI USB Interface Adapter PMBus pod (TI part number EVM USB-TO-GPIO), which can be ordered from the [Texas Instruments Xilinx USB](#) website and the associated TI Fusion Digital Power Designer GUI also downloadable from [Texas Instruments fusion tools](#). This is the simplest and most convenient way to monitor the voltage and current values for the power rail listed in Table 1-22, Table 1-23, and Table 1-24.

In each of these the three tables (one per controller), the Power Good (PG) On Threshold is the set-point at or above which the particular rail is deemed “good”. The PG Off Threshold is the set-point at or below which the particular rail is no longer deemed “good”. The controller internally OR's these PG conditions together and drives an output PG pin high only if all active rail PG states are “good”. The On and Off Delay and rise and fall times are relative to when the board power on-off slide switch SW12 is turned on and off.

Table 1-22 defines the voltage and current values for each power rail controlled by the UCD9248 PMBus controller at address 52 (U42).

Table 1-22: Power Rail Specifications for UCD9248 PMBus Controller at Address 52

Rail Number	Rail Name	Schematic Rail Name	Nominal V_{OUT} (V)	PG On Threshold (V)	PG Off Threshold (V)	On Delay (ms)	Rise Time (ms)	Off Delay (ms)	Fall Time (ms)	Shutdown Threshold ⁽¹⁾		
										V_{OUT} Over Fault (V)	I_{OUT} Over Fault (A)	Temp Over Fault (°C)
1	Rail #1	VCCINT_FPGA	1	0.9	0.85	5	4	35	4	1.15	35	84
2	Rail #2	VCCAUX	1.8	1.62	1.53	20	4	20	4	2.07	9.5	84
3	Rail #3	VCC3V3	3.3	2.97	2.805	35	5	5	5	3.795	9.5	84

Notes:

1. The values defined in these columns are the voltage, current, and temperature thresholds that cause the regulator to shut down if the value is exceeded.

Table 1-23 defines the voltage and current values for each power rail controlled by the UCD9248 PMBus controller at address 53 (U43).

Table 1-23: Power Rail Specifications for UCD9248 PMBus Controller at Address 53

Rail Number	Rail Name	Schematic Rail Name	Nominal V _{OUT} (V)	PG On Threshold (V)	PG Off Threshold (V)	On Delay (ms)	Rise Time (ms)	Off Delay (ms)	Fall Time (ms)	Shutdown Threshold ⁽¹⁾		
										V _{OUT} Over Fault (V)	I _{OUT} Over Fault (A)	Temp Over Fault (°C)
1	Rail #1	VCC2V5_FPGA	2.5	2.25	2.125	35	5	5	1	2.875	9.5	84
2	Rail #2	VCC1V5	1.5	1.35	1.275	30	5	10	1	1.725	9.5	84
3	Rail #3	MGTAVCC	1	0.9	0.85	10	4	35	4	1.45	9.5	84
4	Rail #4	MGTAVTT	1.2	1.08	1.02	15	4	25	4	1.38	9.5	84

Notes:

- The values defined in these columns are the voltage, current, and temperature thresholds that cause the regulator to shut down if the value is exceeded.

Table 1-24 defines the voltage and current values for each power rail controlled by the UCD9248 PMBus controller at address 54 (U64).

Table 1-24: Power Rail Specifications for UCD9248 PMBus Controller at Address 54

Rail Number	Rail Name	Schematic Rail Name	Nominal V _{OUT} (V)	PG On Threshold (V)	PG Off Threshold (V)	On Delay (ms)	Rise Time (ms)	Off Delay (ms)	Fall Time (ms)	Shutdown Threshold ⁽¹⁾		
										V _{OUT} Over Fault (V)	I _{OUT} Over Fault (A)	Temp Over Fault (°C)
1	Rail #1	VCCAUX_IO	2	1.8	1.7	25	5	15	5	2.3	9.5	84
2	Rail #2	NOT USED	1	0.9	0.85	35	4	5	4	1.15	9.5	84
3	Rail #3	MGTVCCAUX	1.8	1.62	1.53	15	4	25	4	2.07	9.5	84
4	Rail #4	VCC1V8_FPGA	1.8	1.62	1.53	30	4	10	4	2.07	9.5	84

Notes:

- The values defined in these columns are the voltage, current, and temperature thresholds that cause the regulator to shut down if the value is exceeded.

FPGA Cooling Fan Operation

The FPGA cooling fan control circuit has its PWM signal wired to a dual-use FPGA bank 15 pin BA37. After configuration, this pin is expected to be toggled by user-provided fan speed control IP to control fan speed. The fan tachometer feedback signal is wired to FPGA bank 15 pin BB37.

FPGA U1 pin BA37 is alternately an unused BPI flash memory address pin (A28). During FPGA configuration in BPI mode, the BPI flash memory address lines are driven. The BA37 pin is held low during BPI configuration and thus the fan PWM signal is not active and the cooling fan is off during the FPGA BPI configuration process.

After configuration is complete, the dual-use FPGA pin BA37 is available for use by user-provided fan speed control IP. If no IP is implemented, this pin should be driven High or placed into high impedance mode so pull-up resistor R198 can pull SM_FAN_PWM high to turn the fan on.

More information about the power system components used by the VC709 board is available from the [Texas Instrument digital power](#) website.

Documentation describing PMBus programming for the UCD9248 digital power controller is available at the [Texas Instruments fusion tools](#) documentation website.

Note: It has been noted that power modules on the VC709 evaluation board that operate at moderate to high current levels (due to a customer design) might generate substantial heat that can result in unexpected power module shutdowns from over-temperature conditions. This then turns off the FPGA on the development board. Refer to the [Virtex-7 VC709 Evaluation Kit Master Answer Record \(AR 51901\)](#) concerning the solution.

XADC Analog-to-Digital Converter

The 7 series FPGAs provide an Analog Front End XADC block. The XADC block includes a dual 12-bit, 1 MSPS Analog-to-Digital Converter (ADC) and on-chip sensors. See *7 Series FPGAs and Zynq-7000 All Programmable SoC XADC Dual 12-Bit 1 MSPS Analog-to-Digital Converter User Guide* (UG480) [Ref 9] for details on the capabilities of the analog front end. [Figure 1-26](#) shows the XADC block diagram.

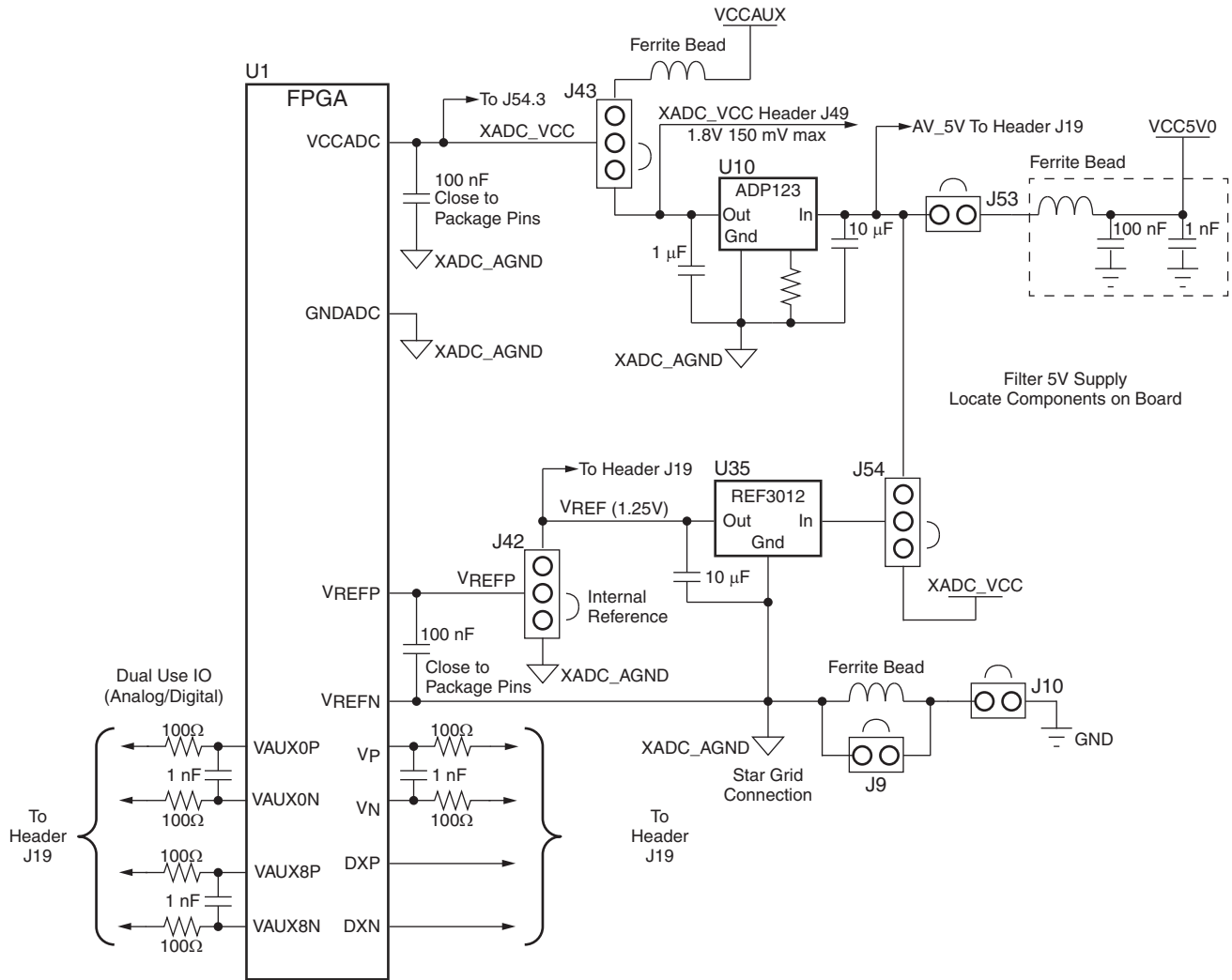

UG887_c1_25_011013

Figure 1-26: XADC Block Diagram

The VC709 board supports both the internal FPGA sensor measurements and the external measurement capabilities of the XADC. Internal measurements of the die temperature, V_{CCINT} , V_{CCAUX} , and V_{CCBRAM} are available. The VC709 board V_{CCINT} and V_{CCBRAM} are provided by a common 1.0 V supply.

Jumper J42 can be used to select either an external differential voltage reference (VREF) or on-chip voltage reference for the analog-to-digital converter.

For external measurements an XADC header (J19) is provided. This header can be used to provide analog inputs to the FPGA dedicated VP/VN channel, and to the VAUXP[0]/VAUXN[0], VAUXP[8]/VAUXN[8] auxiliary analog input channels. Simultaneous sampling of Channel 0 and Channel 8 is supported.

A user-provided analog signal multiplexer card can be used to sample additional external analog inputs using the 4 GPIO pins available on the XADC header as multiplexer address lines.

Figure 1-27 shows the XADC header connections (Figure 1-2, callout 23).

Note: VADJ is fixed at 1.8V on the VC709 board.

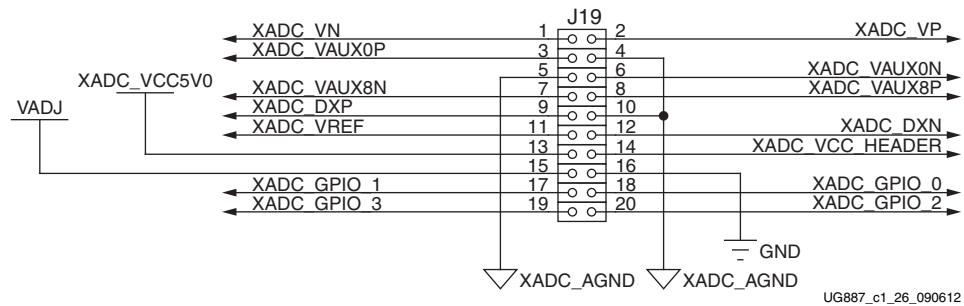

Figure 1-27: XADC header (J19)

Table 1-25 describes the XADC header J19 pin functions.

Table 1-25: XADC Header J19 Pinout

Net Name	J19 Pin Number	Description
VN, VP	1, 2	Dedicated analog input channel for the XADC.
XADC_VAUX0P, N	3, 6	Auxiliary analog input channel 0. Also supports use as I/O inputs when anti-alias capacitor is not present.
XADC_VAUX8N, P	7, 8	Auxiliary analog input channel 8. Also supports use as I/O inputs when anti-alias capacitor is not present.
DXP, DNX	9, 12	Access to thermal diode.
XADC_AGNND	4, 5, 10	Analog ground reference.
XADC_VREF	11	1.25V reference from the board.
XADC_VCC5V0	13	Filtered 5V supply from board.
XADC_VCC_HEADER	14	Analog 1.8V supply for XADC.
VADJ	15	V _{CCO} supply for bank which is the source of DIO pins.
GND	16	Digital ground (board) reference
XADC_GPIO_3, 2, 1, 0	19, 20, 17, 18	Digital I/O. These LVC MOS18 pins are connected to U1 bank 15 pins AN41, AN40, AR39, and AR38, respectively. These I/Os should not be shared with other functions because they are required to support 3-state operation.

Configuration Options

The FPGA on the VC709 board can be configured by the following methods:

- Master BPI (uses the linear BPI flash).
- JTAG (Digilent USB-to-JTAG Bridge only). See [USB JTAG](#) for more information.

See *7 Series FPGAs Configuration User Guide* (UG470) [Ref 3] for further details on configuration modes.

The method used to configure the FPGA is controlled by the mode pin (M2, M1, M0) settings selected through DIP switch SW11. [Table 1-26](#) lists the supported mode switch settings.

Table 1-26: Mode Switch SW11 Settings

Mode Pins (M2, M1, M0)	Configuration Mode
010	Master BPI
101	JTAG

Figure 1-28 shows mode switch SW13.

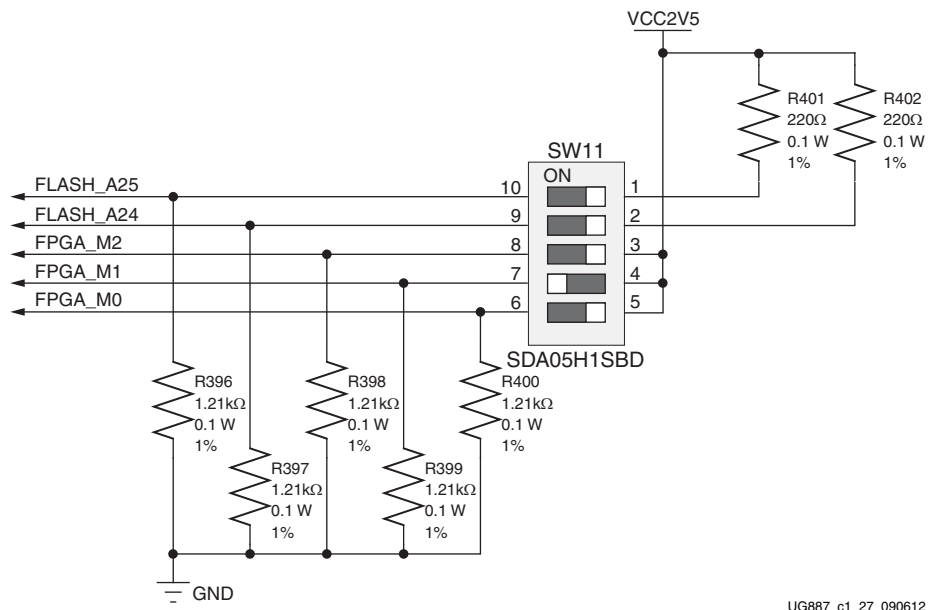
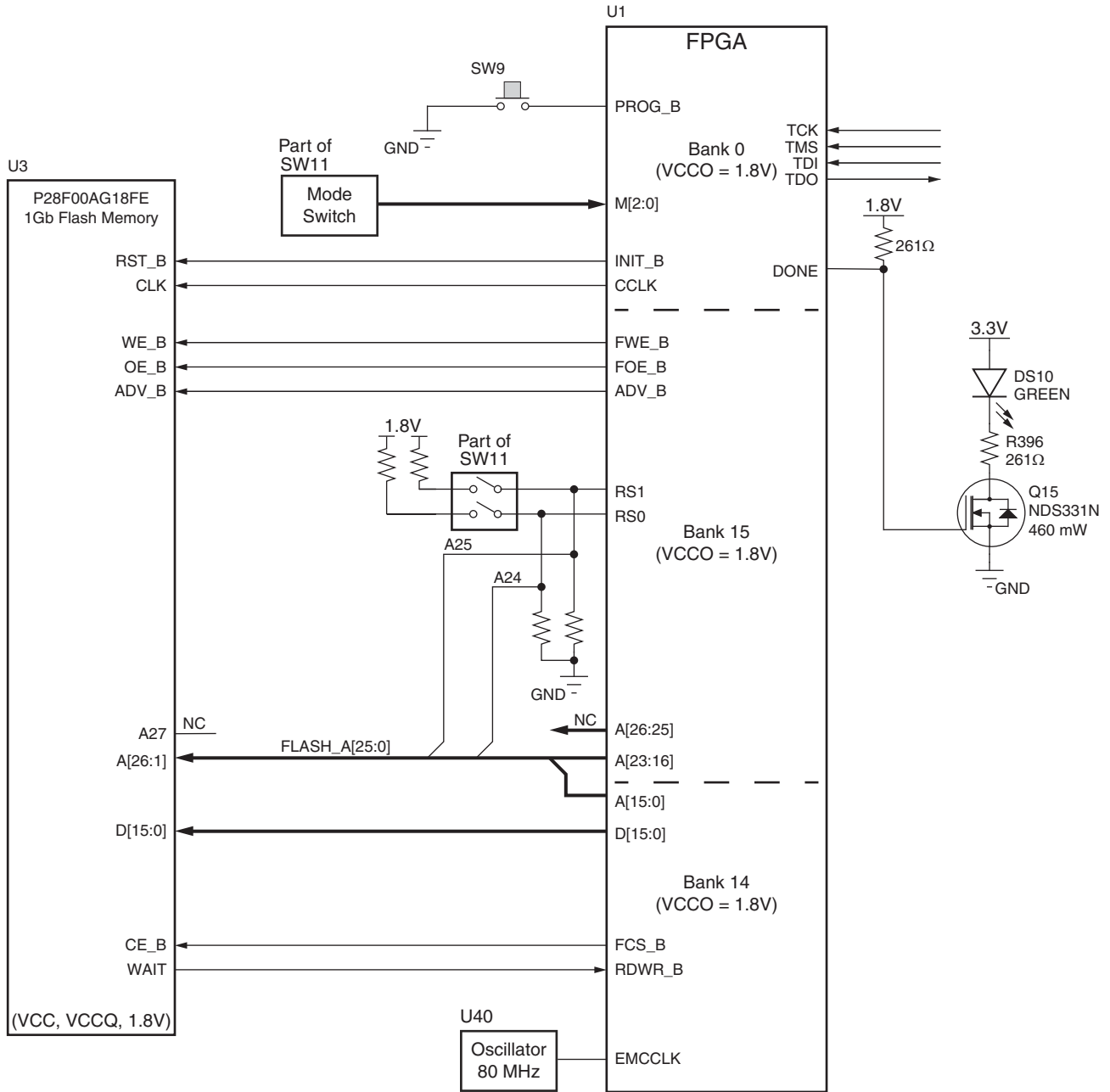

Figure 1-28: Mode Switch

The mode pins settings on SW11 determine if the linear BPI flash is used for configuring the FPGA. DIP switch. SW11 also provides the upper two address bits for the linear BPI flash and can be used to select one of multiple stored configuration bitstreams. Figure 1-29 shows the connectivity between the onboard nonvolatile flash devices used for configuration and the FPGA.

To obtain the fastest configuration speed, an external 80 MHz oscillator is wired to the EMCCLK pin of the FPGA. This allows users to create bitstreams that configure the FPGA over the 16-bit datapath from the linear BPI flash memory at a maximum synchronous read rate of 80 MHz.



UG887_c1_28_052213

Figure 1-29: VC709 Board Configuration Circuit

Default Switch and Jumper Settings

GPIO DIP Switch SW2

See [Figure 1-2](#) Item 24 for the location of SW2. Default settings are shown in [Figure A-1](#) and details are listed in [Table A-1](#).

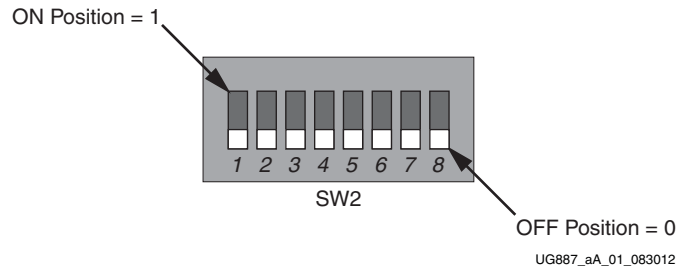

Figure A-1: SW2 Default Settings

Table A-1: SW2 Default Switch Settings

Position	Function	Default
1	GPIO_DIP_SW0	Off
2	GPIO_DIP_SW1	Off
3	GPIO_DIP_SW2	Off
4	GPIO_DIP_SW3	Off
5	GPIO_DIP_SW4	Off
6	GPIO_DIP_SW5	Off
7	GPIO_DIP_SW6	Off
8	GPIO_DIP_SW7	Off

Configuration DIP Switch SW11

See [Figure 1-2](#) Item 29 for the location of SW11. Default settings are shown in [Figure A-2](#) and details are listed in [Table A-2](#).

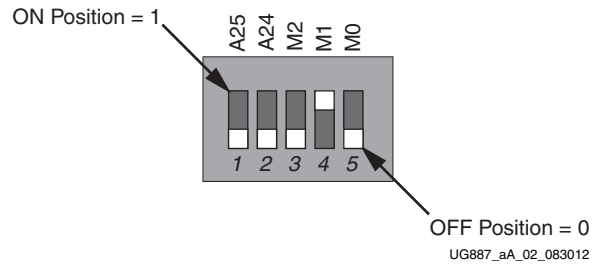

Figure A-2: SW11 Default Settings

The default mode setting $M[2:0] = 010$ selects Master BPI configuration at board power-on.

Table A-2: SW11 Default Switch Settings

Position	Function		Default
1	FLASH_A25	A25	Off
2	FLASH_A24	A24	Off
3	FPGA_M2	M0	Off
4	FPGA_M1	M1	On
5	FPGA_M0	M3	Off

Default Jumper Settings

See [Figure A-3](#) for locations of jumpers listed in [Table A-3](#).

Table A-3: Default Jumper Settings

Jumper Callout	Jumper	Function	Default Jumper Position	Schematic 0381499 Page Number
1	J9	XADC GND ferrite filter bypass jumper	None	27
2	J10	XADC GND-to-XADC_AGND jumper	1-2	27
3	J11	TI controller U42 Addr 52 Reset jumper	None	47
4	J12	TI controller U43 Addr 53 Reset jumper	None	51
5	J42	XADC external 1.2V or internal VREFP selector	1-2	27
6	J43	XADC VCC select header	2-3	27
7	J50	TI controller U64 Addr 54 Reset jumper	None	54
8	J53	XADC VCC5V0-to-XADC_VCC5V0 jumper	1-2	27
9	J54	XADC REF3012 U35 VIN select	1-2	27
10	J49	PCIe bus width select header	1-2	35

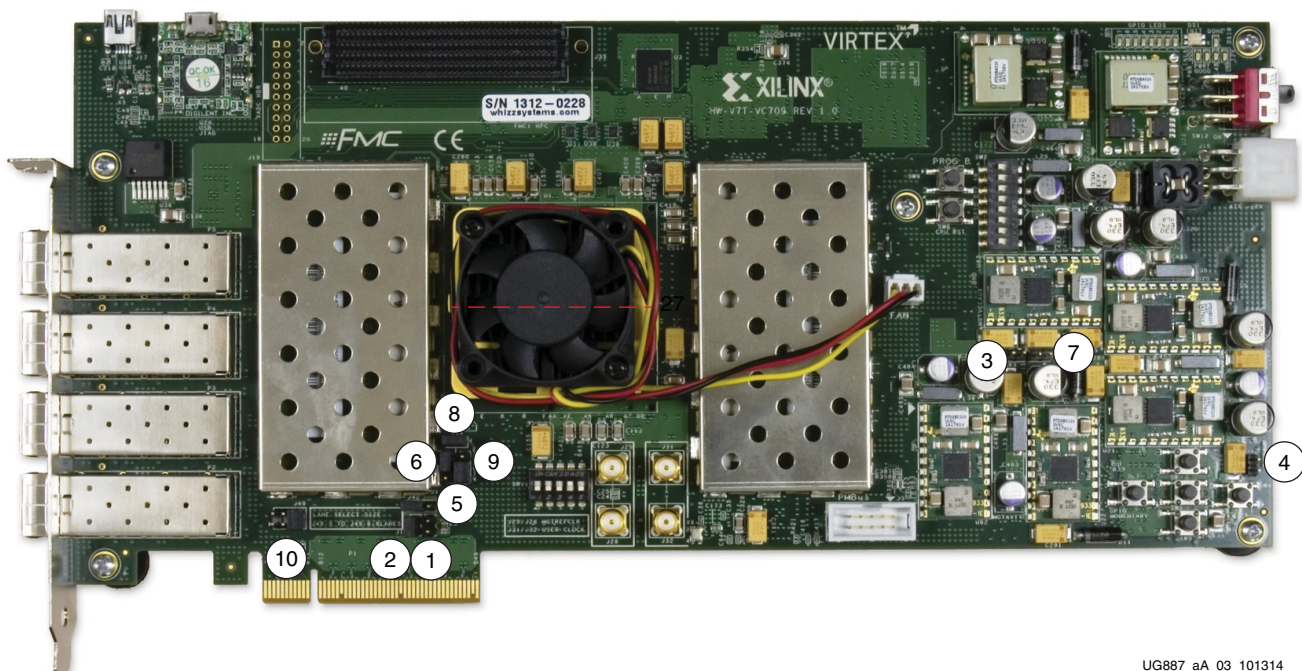

UG887_aA_03_101314

Figure A-3: VC709 Board Jumper Locations

VITA 57.1 FMC Connector Pinouts

Figure B-1 shows the pinout of the FPGA mezzanine card (FMC) high pin count (HPC) connector defined by the VITA 57.1 FMC specification. For a description of how the VC709 board implements the FMC specification, see [VITA 57.1 FMC1 HPC Connector \(Partially Populated\)](#).

	K	J	H	G	F	E	D	C	B	A
1	VREF_B_M2C	GND	VREF_A_M2C	GND	PG_M2C	GND	PG_C2M	GND	RES1	GND
2	GND	CLK3_M2C_P	PRSN_T_M2C_L	CLK1_M2C_P	GND	HA01_P_CC	GND	DP0_C2M_P	GND	DP1_M2C_P
3	GND	CLK3_M2C_N	GND	CLK1_M2C_N	GND	HA01_N_CC	GND	DP0_C2M_N	GND	DP1_M2C_N
4	CLK2_M2C_P	GND	CLK0_M2C_P	GND	HA00_P_CC	GND	GBTCLK0_M2C_P	GND	DP9_M2C_P	GND
5	CLK2_M2C_N	GND	CLK0_M2C_N	GND	HA00_N_CC	GND	GBTCLK0_M2C_N	GND	DP9_M2C_N	GND
6	GND	HA03_P	GND	LA00_P_CC	GND	HA05_P	GND	DP0_M2C_P	GND	DP2_M2C_P
7	HA02_P	HA03_N	LA02_P	LA00_N_CC	HA04_P	HA05_N	GND	DP0_M2C_N	GND	DP2_M2C_N
8	HA02_N	GND	LA02_N	GND	HA04_N	GND	LA01_P_CC	GND	DP8_M2C_P	GND
9	GND	HA07_P	GND	LA03_P	GND	HA09_P	LA01_N_CC	GND	DP8_M2C_N	GND
10	HA06_P	HA07_N	LA04_P	LA03_N	HA08_P	HA09_N	GND	LA06_P	GND	DP3_M2C_P
11	HA06_N	GND	LA04_N	GND	HA08_N	GND	LA05_P	LA06_N	GND	DP3_M2C_N
12	GND	HA11_P	GND	LA08_P	GND	HA13_P	LA05_N	GND	DP7_M2C_P	GND
13	HA10_P	HA11_N	LA07_P	LA08_N	HA12_P	HA13_N	GND	GND	DP7_M2C_N	GND
14	HA10_N	GND	LA07_N	GND	HA12_N	GND	LA09_P	LA10_P	GND	DP4_M2C_P
15	GND	HA14_P	GND	LA12_P	GND	HA16_P	LA09_N	LA10_N	GND	DP4_M2C_N
16	HA17_P_CC	HA14_N	LA11_P	LA12_N	HA15_P	HA16_N	GND	GND	DP6_M2C_P	GND
17	HA17_N_CC	GND	LA11_N	GND	HA15_N	GND	LA13_P	LA14_P	GND	DP6_M2C_N
18	GND	HA18_P	GND	LA16_P	GND	HA20_P	LA13_N	LA14_N	GND	DP5_M2C_P
19	HA21_P	HA18_N	LA15_P	LA16_N	HA19_P	HA20_N	GND	LA14_N	GND	DP5_M2C_N
20	HA21_N	GND	LA15_N	GND	HA19_N	GND	LA17_P_CC	GND	GBTCLK1_M2C_P	GND
21	GND	HA22_P	GND	LA20_P	GND	HB03_P	LA17_N_CC	GND	GBTCLK1_M2C_N	GND
22	HA23_P	HA22_N	LA19_P	LA20_N	HB02_P	HB03_N	GND	LA18_P_CC	GND	DP1_C2M_P
23	HA23_N	GND	LA19_N	GND	HB02_N	GND	LA23_P	LA18_N_CC	GND	DP1_C2M_N
24	GND	HB01_P	GND	LA22_P	GND	HB05_P	LA23_N	GND	DP9_C2M_P	GND
25	HB00_P_CC	HB01_N	LA21_P	LA22_N	HB04_P	HB05_N	GND	GND	DP9_C2M_N	GND
26	HB00_N_CC	GND	LA21_N	GND	HB04_N	GND	LA26_P	LA27_P	GND	DP2_C2M_P
27	GND	HB07_P	GND	LA25_P	GND	HB09_P	LA26_N	LA27_N	GND	DP2_C2M_N
28	HB06_P_CC	HB07_N	LA24_P	LA25_N	HB08_P	HB09_N	GND	GND	DP8_C2M_P	GND
29	HB06_N_CC	GND	LA24_N	GND	HB08_N	GND	TCK	GND	DP8_C2M_N	GND
30	GND	HB11_P	GND	LA29_P	GND	HB13_P	TDI	SCL	GND	DP3_C2M_P
31	HB10_P	HB11_N	LA28_P	LA29_N	HB12_P	HB13_N	TDO	SDA	GND	DP3_C2M_N
32	HB10_N	GND	LA28_N	GND	HB12_N	GND	3P3VAUX	GND	DP7_C2M_P	GND
33	GND	HB15_P	GND	LA31_P	GND	HB19_P	TMS	GND	DP7_C2M_N	GND
34	HB14_P	HB15_N	LA30_P	LA31_N	HB16_P	HB19_N	TRST_L	GA0	GND	DP4_C2M_P
35	HB14_N	GND	LA30_N	GND	HB16_N	GND	GA1	12P0V	GND	DP4_C2M_N
36	GND	HB18_P	GND	LA33_P	GND	HB21_P	3P3V	GND	DP6_C2M_P	GND
37	HB17_P_CC	HB18_N	LA32_P	LA33_N	HB20_P	HB21_N	GND	12P0V	DP6_C2M_N	GND
38	HB17_N_CC	GND	LA32_N	GND	HB20_N	GND	3P3V	GND	GND	DP5_C2M_P
39	GND	VIO_B_M2C	GND	VADJ	GND	VADJ	GND	3P3V	GND	DP5_C2M_N
40	VIO_B_M2C	GND	VADJ	GND	VADJ	GND	3P3V	GND	RES0	GND

UG887_ab_01_083012

Figure B-1: FMC1 HPC Connector Pinout

Xilinx Design Constraints

The VC709 board Xilinx design constraints (XDC) file template provides for designs targeting the VC709 board. Net names in the constraints correlate with net names on the latest VC709 board schematic. Users must identify the appropriate pins and replace the net names listed here with net names in the user RTL. See the *Vivado Design Suite User Guide Using Constraints* (UG903) [Ref 10] for more information.

The FMC connector J35 is connected to 1.8V V_{CCO} banks. Because each user's FMC card implements customer-specific circuitry, the FMC bank I/O standards must be uniquely defined by each customer.

Refer to the boards file on the Virtex-7 FPGA VC709 Evaluation Kit documentation page (www.xilinx.com/vc709), for the latest version of the FPGA xdc constraint file.

Board Setup

Installing the VC709 Board in a PC Chassis

Installation of the VC709 board inside a computer chassis is required when developing or testing PCI Express functionality.

When the VC709 board is used inside a computer chassis (that is, plugged in to the PCIe® slot), power is provided from the ATX power supply 4-pin peripheral connector *only* through the ATX adapter cable shown in [Figure D-1](#) to J18 on the VC709 board. The Xilinx part number for this cable is 2600304. For information on ordering this cable, see [\[Ref 21\]](#).



Figure D-1: ATX Power Supply Adapter Cable

To install the VC709 board in a PC chassis:

1. On the VC709 board, remove all five rubber feet and standoffs. The standoffs and feet are affixed to the board by screws on the top side of the board. Remove all five screws. Re-attach the PCIe bracket with two screws.
2. Power down the host computer and remove the AC power cord from the PC.
3. Open the PC chassis following the instructions provided with the PC.
4. Select a vacant PCIe expansion slot and remove the expansion cover (at the back of the chassis) by removing the screw on the top of the cover.
5. Plug the VC709 board into the PCIe connector at this slot.
6. Secure the card PCIe mounting bracket on the VC709 board with the expansion cover screw.

Note: The VC709 board is taller than standard PCIe cards. Ensure that the height of the card is free of obstructions.
7. Connect the ATX power supply to the VC709 board using the ATX power supply adapter cable as shown in [Figure D-1](#):
 - a. Plug the 6-pin 2 x 3 Molex connector on the adapter cable into J18 on the VC709 board.
 - b. Plug the 4-pin 1 x 4 Molex connector on the opposite end of the adapter cable into an ATX power supply cable bundle mating 4-pin 1 x 4 peripheral power connector.

Caution! Do NOT plug a PC ATX power supply 6-pin connector into J18 on the VC709 board. The ATX 6-pin connector has a different pinout than J18. Connecting an ATX 6-pin connector into J18 may damage the VC709 board and void the board warranty.

8. Slide the VC709 board power switch SW12 to the ON position. The PC can now be plugged in and powered on.

Board Specifications

Dimensions

Height: 5.5 inch (14.0 cm)

Thickness ($\pm 10\%$): 0.062 inch (0.1575 cm)

Length: 10.5 inch (26.7 cm)

Note: The VC709 board height exceeds the standard 4.376 inch (11.15 cm) height of a PCI Express card.

Environmental

Temperature

Operating: 0°C to +45°C

Storage: -25°C to +60°C

Humidity

10% to 90% non-condensing

Operating Voltage

+12 V_{DC}

Regulatory and Compliance Information

This product is designed and tested to conform to the European Union directives and standards described in this section.

Refer to the VC709 board master answer record concerning the CE requirements for the PC Test Environment:

[Virtex-7 VC709 Evaluation Kit Master Answer Record 51901](#)

CE Directives

2006/95/EC, *Low Voltage Directive (LVD)*

2004/108/EC, *Electromagnetic Compatibility (EMC) Directive*

CE Standards

EN standards are maintained by the European Committee for Electrotechnical Standardization (CENELEC). IEC standards are maintained by the International Electrotechnical Commission (IEC).

Electromagnetic Compatibility

EN 55022:2010, *Information Technology Equipment Radio Disturbance Characteristics – Limits and Methods of Measurement*

EN 55024:2010, *Information Technology Equipment Immunity Characteristics – Limits and Methods of Measurement*

This is a Class A product and can cause radio interference. In a domestic environment, the user might be required to take adequate corrective measures.

Safety

IEC 60950-1:2005, *Information technology equipment – Safety, Part 1: General requirements*

EN 60950-1:2006, *Information technology equipment – Safety, Part 1: General requirements*

Markings



In August of 2005, the European Union (EU) implemented the EU WEEE Directive 2002/96/EC and later the WEEE Recast Directive 2012/19/EU requiring Producers of electronic and electrical equipment (EEE) to manage and finance the collection, reuse, recycling and to appropriately treat WEEE that the Producer places on the EU market after August 13, 2005. The goal of this directive is to minimize the volume of electrical and electronic waste disposal and to encourage re-use and recycling at the end of life.

Xilinx has met its national obligations to the EU WEEE Directive by registering in those countries to which Xilinx is an importer. Xilinx has also elected to join WEEE Compliance Schemes in some countries to help manage customer returns at end-of-life.

If you have purchased Xilinx-branded electrical or electronic products in the EU and are intending to discard these products at the end of their useful life, please do not dispose of them with your other household or municipal waste. Xilinx has labeled its branded electronic products with the WEEE Symbol to alert our customers that products bearing this label should not be disposed of in a landfill or with municipal or household waste in the EU.



This product complies with Directive 2002/95/EC on the restriction of hazardous substances (RoHS) in electrical and electronic equipment.



This product complies with CE Directives 2006/95/EC, *Low Voltage Directive (LVD)* and 2004/108/EC, *Electromagnetic Compatibility (EMC) Directive*.

Additional Resources

Xilinx Resources

For support resources such as Answers, Documentation, Downloads, and Forums, see the [Xilinx Support website](#).

For continual updates, add the Answer Record to your [myAlerts](#).

Solution Centers

See the [Xilinx Solution Centers](#) for support on devices, software tools, and intellectual property at all stages of the design cycle. Topics include design assistance, advisories, and troubleshooting tips.

References

The most up to date information related to the VC709 evaluation kit and its documentation is available on these websites:

[Virtex-7 FPGA VC709 Connectivity Kit](#)

[Virtex-7 FPGA VC709 Connectivity Kit Documentation website](#)

[Virtex-7 VC709 Evaluation Kit Master Answer Record 51901](#)

These Xilinx documents and sites provide supplemental material useful with this guide:

1. *7 Series FPGAs Overview* ([DS180](#))
2. *Virtex-7 T and XT FPGAs Data Sheet: DC and AC Switching Characteristics* ([DS183](#))
3. *7 Series FPGAs Configuration User Guide* ([UG470](#))
4. *7 Series FPGAs Memory Interface Solutions User Guide* ([UG586](#))
5. *7 Series FPGAs Memory Resources User Guide* ([UG473](#))
6. *7 Series FPGAs GTX/GTH Transceivers User Guide* ([UG476](#))
7. *7 Series FPGAs Integrated Block for PCI Express User Guide* ([PG054](#))
8. *7 Series FPGAs PCB Design and Pin Planning Guide* ([UG483](#))
9. *7 Series FPGAs and Zynq-7000 All Programmable SoC XADC Dual 12-Bit 1 MSPS Analog-to-Digital Converter User Guide* ([UG480](#))
10. *Vivado Design Suite User Guide Using Constraints* ([UG903](#))
11. *7 Series FPGAs Packaging and Pinout Product Specification* ([UG475](#))
12. *XC7VX690T* ([UG886](#))

These external websites provide supplemental material useful with this guide: Use the website search function to find information for the items listed with each link:

13. [Micron Technology](#)
PC28F00AG18FE/MT28GU01GAAA1EGC-0SIT, MT8KTF51264HZ-1G9
14. [Si Time](#)
SiT9102, SiT9122
15. [Silicon Labs](#)
Si570, Si5324C, CP2103GM, VCP Drivers
16. [Texas Instruments](#)
UCD9248PFC, PTD08A010W, PTD08A020W, PTD08D021W, LMZ12002, TL1962ADC, TPS51200DR, PCA9548, PCA9546
17. [Texas Instrument digital power](#)
Digital power solutions webpage
18. [Texas Instruments fusion tools](#)
Fusion Digital Power Designer graphical user interface software
19. [Texas Instruments Xilinx USB](#)
USB to GPIO Interface Adapter
20. [Analog Devices](#)
ADP123
21. [Sourcegate Technologies](#)
To order the custom Sourcegate cable, contact sgt-sales@sourcegate.net, +65 6483 2878 for price and availability.

Note: The Xilinx ATX cable part number 2600304 is manufactured by Sourcegate Technologies and is equivalent to the Sourcegate Technologies part number AZCBL-WH-11009. Sourcegate only manufactures the latest revision. This is a custom cable and cannot be ordered from the Sourcegate website.

Данный компонент на территории Российской Федерации

Вы можете приобрести в компании MosChip.

Для оперативного оформления запроса Вам необходимо перейти по данной ссылке:

<http://moschip.ru/get-element>

Вы можете разместить у нас заказ для любого Вашего проекта, будь то серийное производство или разработка единичного прибора.

В нашем ассортименте представлены ведущие мировые производители активных и пассивных электронных компонентов.

Нашей специализацией является поставка электронной компонентной базы двойного назначения, продукции таких производителей как XILINX, Intel (ex.ALTERA), Vicor, Microchip, Texas Instruments, Analog Devices, Mini-Circuits, Amphenol, Glenair.

Сотрудничество с глобальными дистрибьюторами электронных компонентов, предоставляет возможность заказывать и получать с международных складов практически любой перечень компонентов в оптимальные для Вас сроки.

На всех этапах разработки и производства наши партнеры могут получить квалифицированную поддержку опытных инженеров.

Система менеджмента качества компании отвечает требованиям в соответствии с ГОСТ Р ИСО 9001, ГОСТ РВ 0015-002 и ЭС РД 009

Офис по работе с юридическими лицами:

105318, г.Москва, ул.Щербаковская д.3, офис 1107, 1118, ДЦ «Щербаковский»

Телефон: +7 495 668-12-70 (многоканальный)

Факс: +7 495 668-12-70 (доб.304)

E-mail: info@moschip.ru

Skype отдела продаж:

moschip.ru

moschip.ru_4

moschip.ru_6

moschip.ru_9